

THIS PRODUCT MANUFACTURED WITH LEAD-FREE PROCESSING

DESIGNED & DIMENSIONED IN MILLIMETERS(INCHES)

ECUE-XX-XXX-XX-XX-XX-1-XX

No OF PAIRS
-12 (T1 & C1 CABLE ONLY)
-08 (T2 CABLE ONLY)

ASSEMBLY LENGTH
007 - 999 cm (SEE NOTE 8)

SHIELDED CABLE TYPE
-C1: TCF-3850 (38AWG COAX,12 PAIRS ONLY)
-T1: TTF-36100 (36AWG TWINAX,12 PAIRS ONLY)
-T2: TTF-34100 (34AWG TWINAX, 8 PAIRS ONLY)

OPTION
BLANK: STANDARD FIREFLY
-D1: DECOUPLING CAPACITORS (SEE NOTE 7)
ONLY AVAILABLE WITH -02 & -B4 WIRE OPTION
NOT AVAILABLE WITH -EC OPTION

WIRING OPTION (SEE TABLE 1)
-01 "A1 TO A19"
-02 "A1 TO B1"
-B4 (8 PAIR ONLY) "A1 TO B19"

END 2 OPTION
-FF: ECUE
*-EC: ECDP

* NOT TOOLED

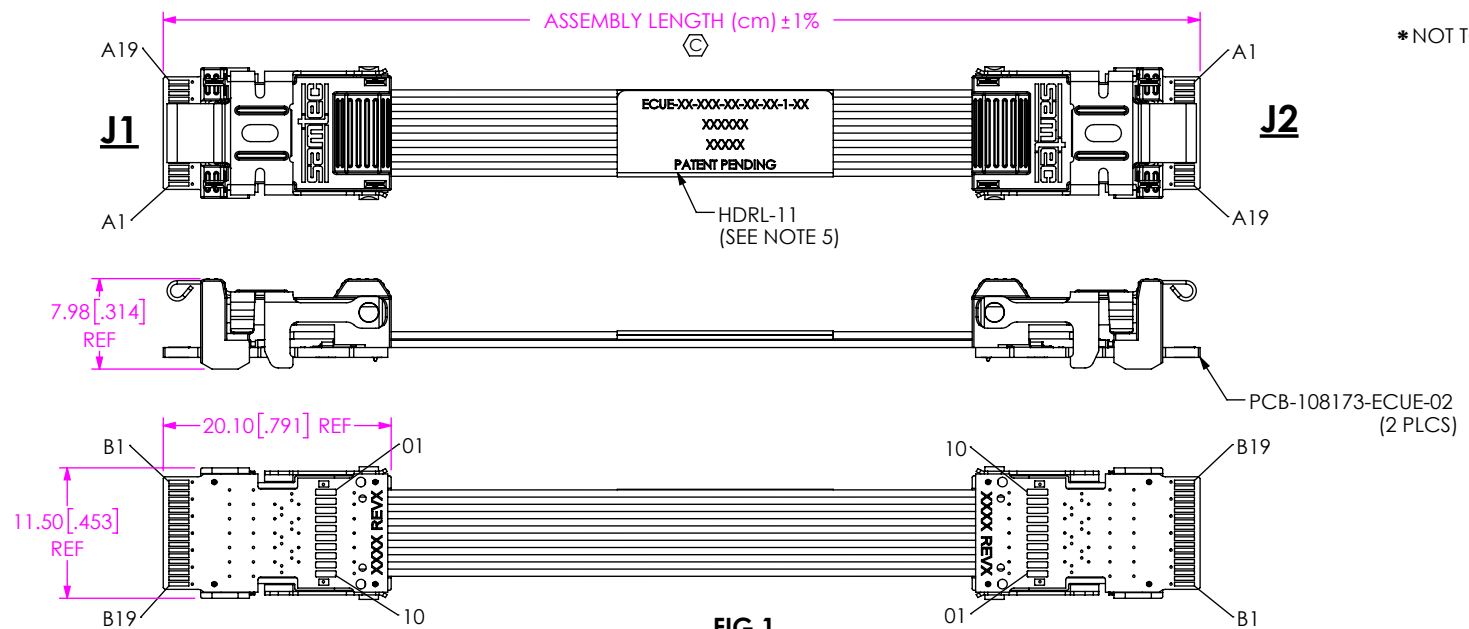

TABLE 1

WIRING OPTION	END 1		END 2	
	-FF	-FF	*-EC	
	ECUE PIN #	ECUE PIN #	ECDP PIN #	
01	A1	A19	1	
02	A1	B1	38	
B4	A1	B19	NA	

* NOT TOOLED

FIG 1
WIRING OPTION -01
ECUE-12-XXX-X1-FF-01-1 SHOWN

TABLE 2
ECUE-12-XXX-X1-FF-01-1 SIGNAL MAPPING
(12 PAIRS, -01 WIRING OPTION)

J1	A1	A2	A3	A4	A5	A6	A7	A8	A9	A10	A11	A12	A13	A14	A15	A16	A17	A18	A19	B1	B2	B3	B4	B5	B6	B7	B8	B9	B10	B11	B12	B13	B14	B15	B16	B17	B18	B19			
NAME	G	S	S	G	S	S	G	S	S	G	S	S	G	S	S	G	S	S	G	G	S	S	G	S	S	G	S	S	G	S	S	G	S	S	G	S	S	G	S	S	G
J2	A19	A18	A17	A16	A15	A14	A13	A12	A11	A10	A9	A8	A7	A6	A5	A4	A3	A2	A1	B19	B18	B17	B16	B15	B14	B13	B12	B11	B10	B9	B8	B7	B6	B5	B4	B3	B2	B1			

- NOTES:
- ⊗ REPRESENTS A CRITICAL DIMENSION
 - PARTS TO BE PROCESSED PER SAMTEC WORKMANSHIP GUIDELINES
 - ALL ASSEMBLIES TO BE 100% ELECTRICALLY TESTED
 - ALL ASSEMBLIES TO BE 100% HI-POT TESTED AT 300V
 - LABEL TO BE CENTERED ON CABLE AS SHOWN. LABEL TO CONTAIN:
LINE 1 - PART NUMBER "ECUE-XX-XXX-XX-XX-XX-1-XX"
LINE 2 - SHOP ORDER NUMBER "XXXXXX"
LINE 3 - DATE CODE "XXXXX"
LINE 4 - PATENT PENDING
 - FOR SUB-ASSEMBLY AND FINISHED GOOD PACKAGING REQUIREMENTS, REFERENCE SAMTEC PACKAGING STANDARD
 - D1 OPTION USES 0.1µF DECOUPLING CAPACITORS
 - CABLE LENGTHS LONGER THAN 150 cm NOT SUPPORTED BY SI TEST DATA
 - PIN 3 ON UCC8 CONNECTION TIED TO GROUND, REMAINDER ARE NO CONNECT

TOLERANCES DO NOT APPLY TO REFERENCE DIMENSIONS, UNLESS OTHERWISE SPECIFIED, DIMENSIONS ARE IN MILLIMETERS.

TOLERANCES ARE:
DECIMALS: X: ±.3[.01]
.XX: ±.13[.005]
.XXX: ±.051[.0020]

ANGLES: 2°

PROPRIETARY NOTE

THIS DOCUMENT CONTAINS CONFIDENTIAL AND PROPRIETARY INFORMATION AND ALL DESIGN, MANUFACTURING, REPRODUCTION, USE, PATENT RIGHTS AND SALES RIGHTS ARE EXPRESSLY RESERVED BY SAMTEC, INC. THIS DOCUMENT SHALL NOT BE DISCLOSED, IN WHOLE OR PART, TO ANY UNAUTHORIZED PERSON OR ENTITY NOR REPRODUCED, TRANSFERRED OR INCORPORATED IN ANY OTHER PROJECT IN ANY MANNER WITHOUT THE EXPRESS WRITTEN CONSENT OF SAMTEC, INC.

MATERIAL: DO NOT SCALE DRAWING
HOUSING: LCP
LATCH: STAINLESS STEEL
WELD TAB: BRASS
CABLE: JACKET: PVC
DIELECTRIC: FEP
CONDUCTORS: SILVER PLATED COPPER
SHIELD: SERVED SILVER PLATED COPPER
PCB: FR4, COPPER

samtec

520 PARK EAST BLVD, NEW ALBANY, IN 47150
PHONE: 812-944-6733 FAX: 812-948-5047
e-Mail: info@SAMTEC.com code 55322

DESCRIPTION: FIREFLY CABLE ASSEMBLY

DWG. NO. ECUE-XX-XXX-XX-XX-XX-1-XX

BY: RMSANTOS 10/9/2014 SHEET 1 OF 6

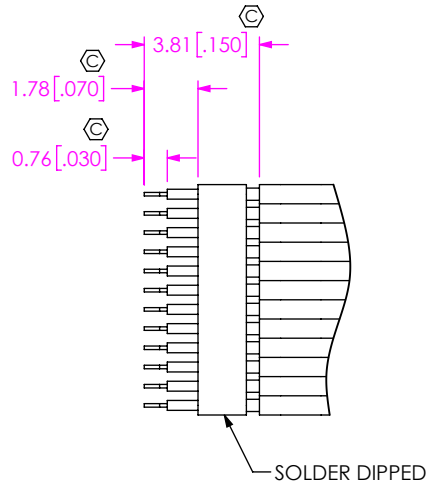

STRIP DIMENSIONS

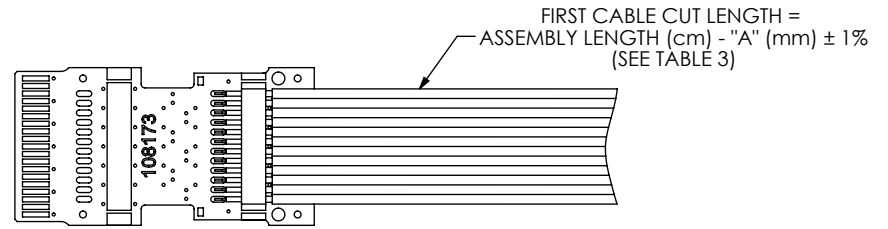

IN PROCESS 1
SOLDER FIRST CABLE TO PCB

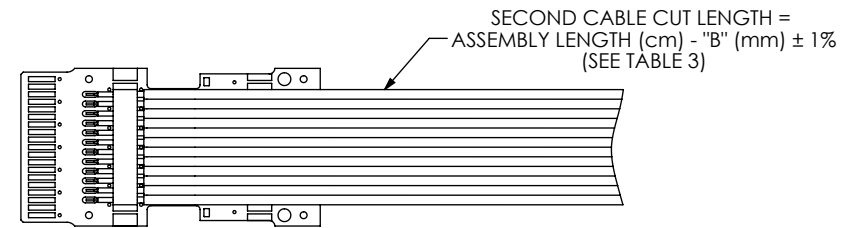

IN PROCESS 2
SOLDER SECOND CABLE TO PCB

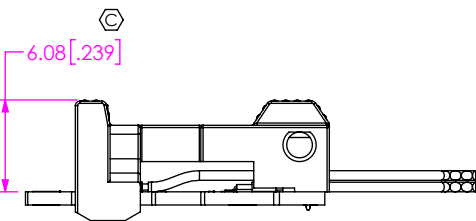
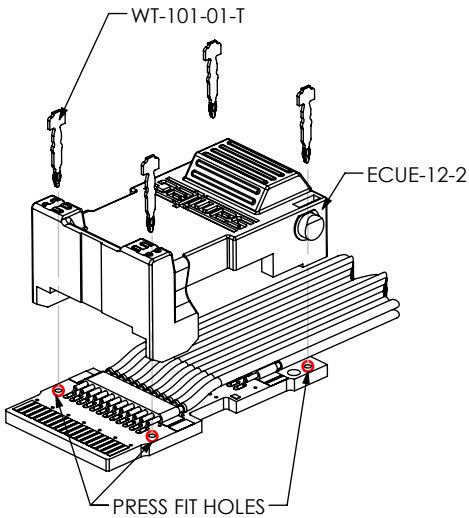

IN PROCESS 3
INSERT WELD TABS & ATTACH TO BOARD

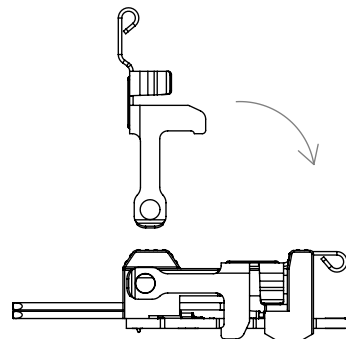
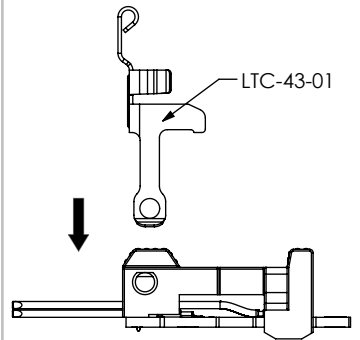

IN PROCESS 4
ATTACH LATCH AND ROTATE INTO DOWN POSITION

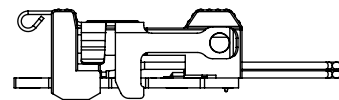

IN PROCESS 5
SOLDER WELD TABS

TABLE 3						
WIRING OPTION						
END 2 OPTION	-01		-02		-B4	
	"A" mm[in.]	"B" mm[in.]	"A" mm[in.]	"B" mm[in.]	"A" mm[in.]	"B" mm[in.]
-FF: ECUE	26.29 [1.035]	8.51 [0.335]	17.41 [0.685]	17.41 [0.685]	16.41 [0.646]	16.41 [0.646]
-EC: ECDP	22.32 [0.879]	12.91 [0.508]	22.32 [0.879]	12.91 [0.508]	22.32 [0.879]	12.91 [0.508]

PROPRIETARY NOTE
THIS DOCUMENT CONTAINS CONFIDENTIAL AND PROPRIETARY INFORMATION AND ALL DESIGN, MANUFACTURING, REPRODUCTION, USE, PATENT RIGHTS AND SALES RIGHTS ARE EXPRESSLY RESERVED BY SAMTEC, INC. THIS DOCUMENT SHALL NOT BE DISCLOSED, IN WHOLE OR PART, TO ANY UNAUTHORIZED PERSON OR ENTITY NOR REPRODUCED, TRANSFERRED OR INCORPORATED IN ANY OTHER PROJECT IN ANY MANNER WITHOUT THE EXPRESS WRITTEN CONSENT OF SAMTEC, INC.

DO NOT SCALE DRAWING



520 PARK EAST BLVD, NEW ALBANY, IN 47150
PHONE: 812-944-6733 FAX: 812-948-5047
e-Mail info@SAMTEC.com code 55322

DESCRIPTION:
FIREFLY CABLE ASSEMBLY
DWG. NO.
ECUE-XX-XXX-XX-XX-XX-1-XX
BY: RMSANTOS 10/9/2014 SHEET 2 OF 6

FIG 2
 WIRING OPTION -02
 ECUE-12-XXX-T1-FF-02-1-D1 SHOWN
 (SAME AS FIG 1 EXCEPT AS NOTED)

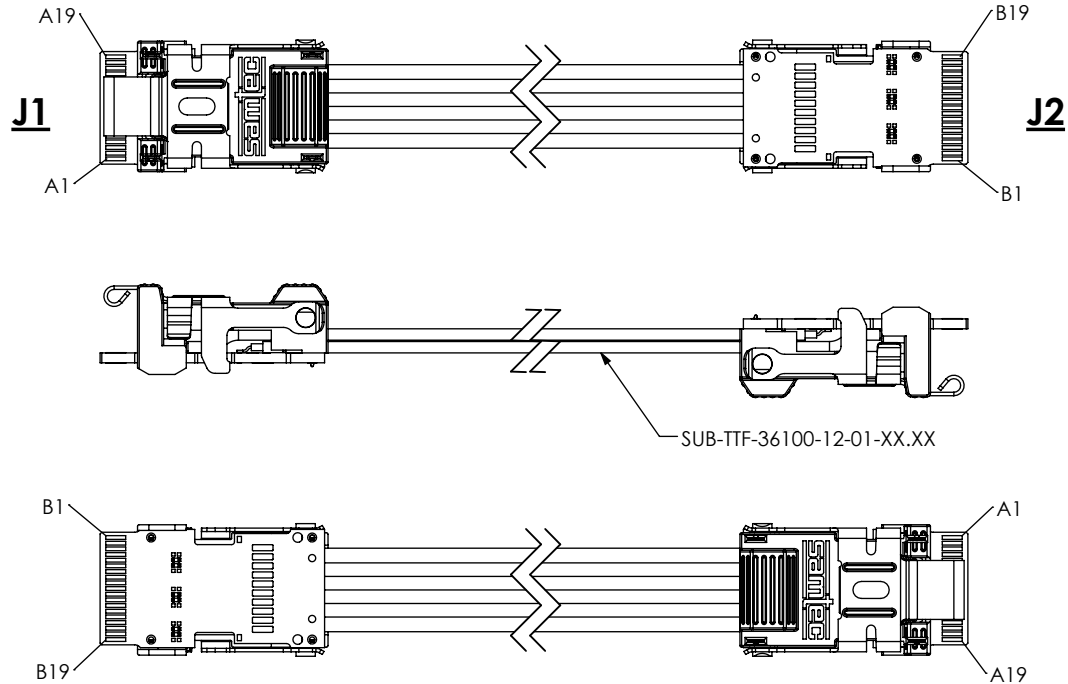

TABLE 4
 ECUE-12-XXX-X1-FF-02-1-XX SIGNAL MAPPING
 (12 PAIRS, -02 WIRING OPTION)

J1	A1	A2	A3	A4	A5	A6	A7	A8	A9	A10	A11	A12	A13	A14	A15	A16	A17	A18	A19	B1	B2	B3	B4	B5	B6	B7	B8	B9	B10	B11	B12	B13	B14	B15	B16	B17	B18	B19
NAME	G	S	S	G	S	S	G	S	S	G	S	S	G	S	S	G	S	S	G	B1	B2	B3	B4	B5	B6	B7	B8	B9	B10	B11	B12	B13	B14	B15	B16	B17	B18	B19
J2	B1	B2	B3	B4	B5	B6	B7	B8	B9	B10	B11	B12	B13	B14	B15	B16	B17	B18	B19	A1	A2	A3	A4	A5	A6	A7	A8	A9	A10	A11	A12	A13	A14	A15	A16	A17	A18	A19

PROPRIETARY NOTE
 THIS DOCUMENT CONTAINS CONFIDENTIAL AND PROPRIETARY INFORMATION AND ALL DESIGN, MANUFACTURING, REPRODUCTION, USE, PATENT RIGHTS AND SALES RIGHTS ARE EXPRESSLY RESERVED BY SAMTEC, INC. THIS DOCUMENT SHALL NOT BE DISCLOSED, IN WHOLE OR PART, TO ANY UNAUTHORIZED PERSON OR ENTITY NOR REPRODUCED, TRANSFERRED OR INCORPORATED IN ANY OTHER PROJECT IN ANY MANNER WITHOUT THE EXPRESS WRITTEN CONSENT OF SAMTEC, INC.



520 PARK EAST BLVD, NEW ALBANY, IN 47150
 PHONE: 812-944-6733 FAX: 812-948-5047
 e-Mail info@SAMTEC.com code 55322

DESCRIPTION:
 FIREFLY CABLE ASSEMBLY
 DWG. NO.
ECUE-XX-XXX-XX-XX-XX-1-XX
 BY: RMSANTOS 10/9/2014 SHEET 3 OF 6

FIG 3
ECUE-12-XXX-C1-FF-02-1-D1 SHOWN
(SAME AS FIG 1 EXCEPT AS NOTED)

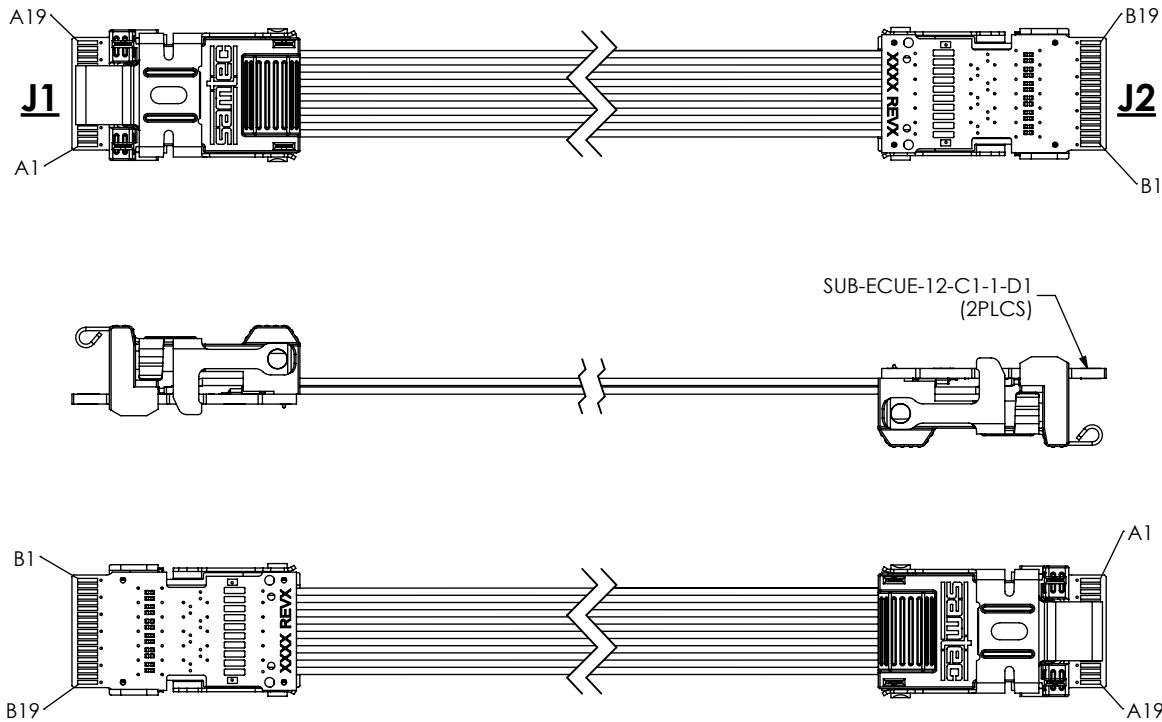

Pb THIS PRODUCT MANUFACTURED WITH LEAD-FREE PROCESSING

J1 & J2
SUB-ECUE-12-C1-1-D1

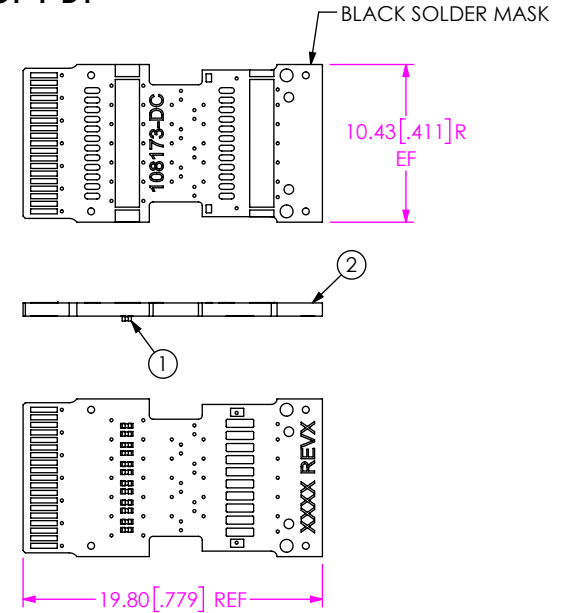

SUB-ECUE-12-C1-1-D1 BOM			
ITEM NO.	PART NUMBER	QUANTITY	MATERIAL
1	CAP-0201-104-K-06.3-SM	12	CAP
2	PCB-108173-ECUE-DC-01	0.05	PCB

TABLE 5

No OF PAIRS	CABLE TYPE	END 2 OPTION	DC OPTION	PCBX-XXXXXX		SUB-TXF-XXXX
				END 1	END 2	
-08	-T2	-FF	(BLANK)	PCB-108175-ECUE-02	PCB-108175-ECUE-02	SUB-TTF-34100-04-01-XX.XX
			-D1	PCBA-199848-ECUE-DC-01	PCBA-199848-ECUE-DC-01	SUB-TTF-34100-04-01-XX.XX
-12	-C1	-FF	(BLANK)	PCB-108173-ECUE-02	PCB-108173-ECUE-02	SUB-TCF-3850-12-01-DP-XX.XX
			-D1	SUB-ECUE-12-C1-1-D1	SUB-ECUE-12-C1-1-D1	SUB-TCF-3850-12-01-DP-XX.XX
		-EC*	(BLANK)	PCB-108173-ECUE-02	PCB-104465-HDR-01	SUB-TCF-3850-12-01-DP-XX.XX
			-D1	N/A	N/A	SUB-TCF-3850-12-01-DP-XX.XX
-T1	-FF	(BLANK)	PCB-108177-ECUE-02	PCB-108177-ECUE-02	SUB-TTF-36100-06-01-XX.XX	
		-D1	PCBA-199130-ECUE-E-03	PCBA-199130-ECUE-E-03	SUB-TTF-36100-06-01-XX.XX	

PROPRIETARY NOTE
THIS DOCUMENT CONTAINS CONFIDENTIAL AND PROPRIETARY INFORMATION AND ALL DESIGN, MANUFACTURING, REPRODUCTION, USE, PATENT RIGHTS AND SALES RIGHTS ARE EXPRESSLY RESERVED BY SAMTEC, INC. THIS DOCUMENT SHALL NOT BE DISCLOSED, IN WHOLE OR PART, TO ANY UNAUTHORIZED PERSON OR ENTITY NOR REPRODUCED, TRANSFERRED OR INCORPORATED IN ANY OTHER PROJECT IN ANY MANNER WITHOUT THE EXPRESS WRITTEN CONSENT OF SAMTEC, INC.



520 PARK EAST BLVD, NEW ALBANY, IN 47150
PHONE: 812-944-6733 FAX: 812-948-5047
e-Mail info@SAMTEC.com code 55322

DESCRIPTION: FIREFLY CABLE ASSEMBLY
DWG. NO. ECUE-XX-XXX-XX-XX-1-XX
BY: RMSANTOS 10/9/2014 SHEET 4 OF 6

TABLE 6
ECUE-08-XXX-T2-FF-01-1 SIGNAL MAPPING
(8 PAIRS, -01 WIRING OPTION)

J1	A1	A2	A3	A4	A5	A6	A7	A8	A9	A10	A11	A12	A13	A14	A15	A16	A17	A18	A19	B1	B2	B3	B4	B5	B6	B7	B8	B9	B10	B11	B12	B13	B14	B15	B16	B17	B18	B19
NAME	G	S	S	G	S	S	G	NC	NC	NC	NC	NC	G	S	S	G	S	S	G	G	S	S	G	S	S	G	NC	NC	NC	NC	NC	G	S	S	G	S	S	G
J2	A19	A18	A17	A16	A15	A14	A13	A12	A11	A10	A9	A8	A7	A6	A5	A4	A3	A2	A1	B19	B18	B17	B16	B15	B14	B13	B12	B11	B10	B9	B8	B7	B6	B5	B4	B3	B2	B1

TABLE 7
ECUE-08-XXX-T2-FF-02-1-XX SIGNAL MAPPING
(8 PAIRS, -02 WIRING OPTION)

J1	A1	A2	A3	A4	A5	A6	A7	A8	A9	A10	A11	A12	A13	A14	A15	A16	A17	A18	A19	B1	B2	B3	B4	B5	B6	B7	B8	B9	B10	B11	B12	B13	B14	B15	B16	B17	B18	B19
NAME	G	S	S	G	S	S	G	NC	NC	NC	NC	NC	G	S	S	G	S	S	G	G	S	S	G	S	S	G	NC	NC	NC	NC	NC	G	S	S	G	S	S	G
J2	B1	B2	B3	B4	B5	B6	B7	B8	B9	B10	B11	B12	B13	B14	B15	B16	B17	B18	B19	A1	A2	A3	A4	A5	A6	A7	A8	A9	A10	A11	A12	A13	A14	A15	A16	A17	A18	A19

TABLE 8
ECUE-08-XXX-T2-FF-B4-1-XX SIGNAL MAPPING
(8 PAIRS, -B4 WIRING OPTION)

J1	A1	A2	A3	A4	A5	A6	A7	A8	A9	A10	A11	A12	A13	A14	A15	A16	A17	A18	A19	B1	B2	B3	B4	B5	B6	B7	B8	B9	B10	B11	B12	B13	B14	B15	B16	B17	B18	B19
NAME	G	S	S	G	S	S	G	NC	NC	NC	NC	NC	G	S	S	G	S	S	G	G	S	S	G	S	S	G	NC	NC	NC	NC	NC	G	S	S	G	S	S	G
J2	B19	B18	B17	B16	B15	B14	B13	B12	B11	B10	B9	B8	B7	B6	B5	B4	B3	B2	B1	A19	A18	A17	A16	A15	A14	A13	A12	A11	A10	A9	A8	A7	A6	A5	A4	A3	A2	A1

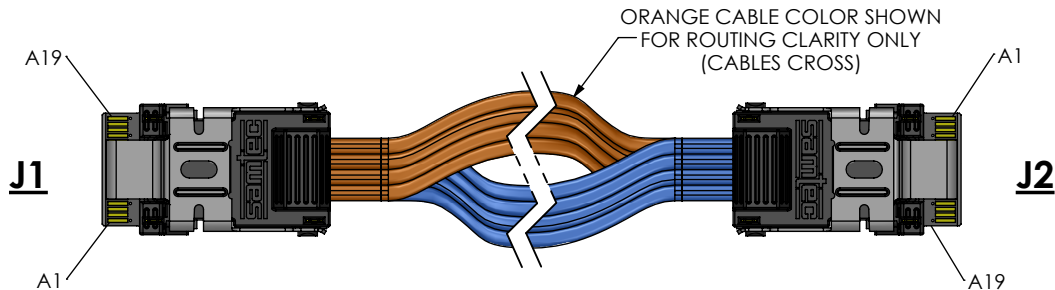
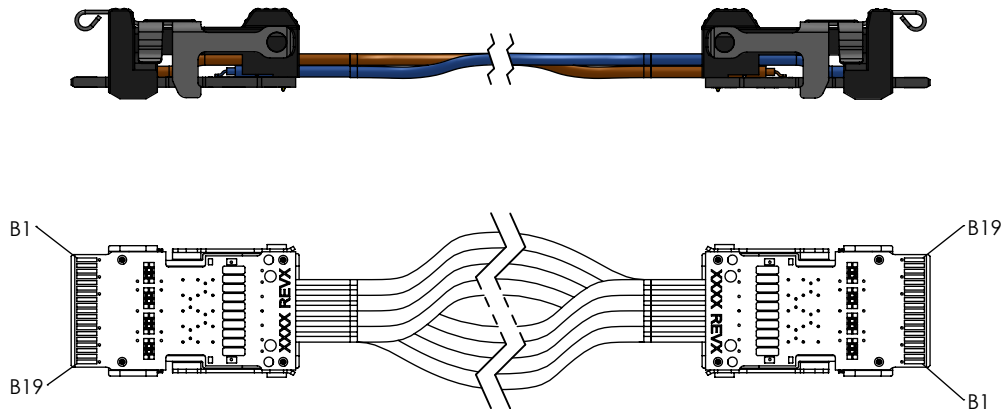

FIG 4
WIRING OPTION -B4
ECUE-08-XXX-T2-FF-B4-1-D1 SHOWN
(SAME AS FIG1 EXCEPT AS NOTED)



PROPRIETARY NOTE
 THIS DOCUMENT CONTAINS CONFIDENTIAL AND PROPRIETARY INFORMATION AND ALL DESIGN, MANUFACTURING, REPRODUCTION, USE, PATENT RIGHTS AND SALES RIGHTS ARE EXPRESSLY RESERVED BY SAMTEC, INC. THIS DOCUMENT SHALL NOT BE DISCLOSED, IN WHOLE OR PART, TO ANY UNAUTHORIZED PERSON OR ENTITY NOR REPRODUCED, TRANSFERRED OR INCORPORATED IN ANY OTHER PROJECT IN ANY MANNER WITHOUT THE EXPRESS WRITTEN CONSENT OF SAMTEC, INC.



520 PARK EAST BLVD., NEW ALBANY, IN 47150
 PHONE: 812-944-6733 FAX: 812-948-5047
 e-Mail info@SAMTEC.com code 55322

DO NOT SCALE DRAWING

DESCRIPTION:
 FIREFLY CABLE ASSEMBLY

SHEET SCALE: 1:1

DWG. NO.
ECUE-XX-XXX-XX-XX-XX-1-XX

BY: RMSANTOS 10/9/2014 SHEET 5 OF 6

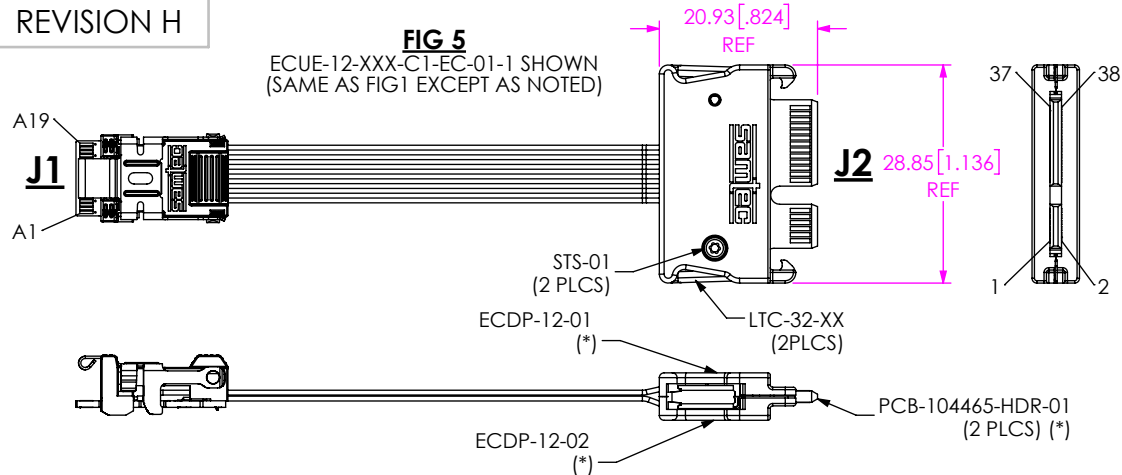

TABLE 9
ECUE-12-XXX-C1-EC-01-1 SIGNAL MAPPING
(12 PAIRS, -EC-01 WIRING OPTION)

J1	A1	A2	A3	~	A17	A18	A19	B1	B2	B3	~	B17	B18	B19
NAME	G	S	S	~	S	S	G	G	S	S	~	S	S	G
J2	1	3	5	~	33	35	37	2	4	6	~	34	36	38

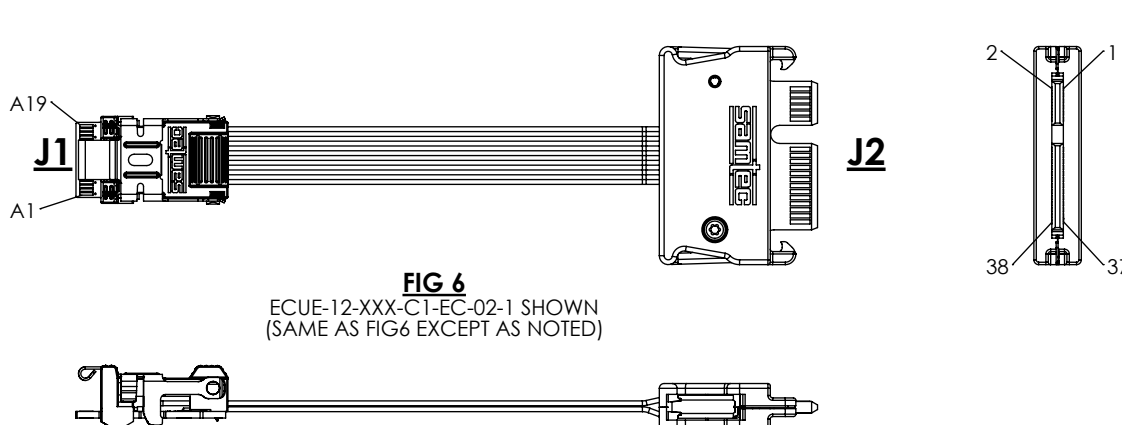

TABLE 10
ECUE-12-XXX-C1-EC-02-1 SIGNAL MAPPING
(12 PAIRS, -EC-02 WIRING OPTION)

J1	A1	A2	A3	~	A17	A18	A19	B1	B2	B3	~	B17	B18	B19
NAME	G	S	S	~	S	S	G	G	S	S	~	S	S	G
J2	38	36	34	~	6	4	2	37	35	33	~	5	3	1

TABLE 13
*ECDP POSITIONS

No OF PAIRS	*ECDP POSITIONS																			
-12	1	3	5	7	9	11	KEY	13	15	17	19	21	23	25	27	29	31	33	35	37
	G	S	S	G	S	S		G	S	S	G	S	S	G	S	S	G	S	S	G
	G	S	S	G	S	S		G	S	S	G	S	S	G	S	S	G	S	S	G
	2	4	6	8	10	12		14	16	18	20	22	24	26	28	30	32	34	36	38

*NOT TOOLED

PROPRIETARY NOTE
THIS DOCUMENT CONTAINS CONFIDENTIAL AND PROPRIETARY INFORMATION AND ALL DESIGN, MANUFACTURING, REPRODUCTION, USE, PATENT RIGHTS AND SALES RIGHTS ARE EXPRESSLY RESERVED BY SAMTEC, INC. THIS DOCUMENT SHALL NOT BE DISCLOSED, IN WHOLE OR PART, TO ANY UNAUTHORIZED PERSON OR ENTITY NOR REPRODUCED, TRANSFERRED OR INCORPORATED IN ANY OTHER PROJECT IN ANY MANNER WITHOUT THE EXPRESS WRITTEN CONSENT OF SAMTEC, INC.



520 PARK EAST BLVD, NEW ALBANY, IN 47150
PHONE: 812-944-6733 FAX: 812-948-5047
e-Mail info@SAMTEC.com code 55322

DO NOT SCALE DRAWING

DESCRIPTION:
FIREFLY CABLE ASSEMBLY

SHEET SCALE: 1:1

DWG. NO.
ECUE-XX-XXX-XX-XX-XX-1-XX

BY: RMSANTOS 10/9/2014 SHEET 6 OF 6