

1. PRODUCT NUMBER AND PRODUCT NAME

1.1 Housing

Part Number	Product Name
1473244	81POS Plug Housing Assembly
1473247	81POS Lever Assembly (TYPE-A)
1473250	81POS Lever Assembly (TYPE-B)
368382	Retainer for 81POS MQS Plug
1473252	40POS Plug Housing Assembly
1473255	40POS Lever Assembly (TYPE-A)
368388	Retainer for 40POS MQS Plug
936054	Cavity Plug for MQS
828922	Cavity Plug for JPT
1241434	121POS Cap Housing Assembly

Fig.1

1.2 Contact

Part Number	Product Name	Applicable Wire Range
968220-1	MQS Clean Body Contact (Female)	0.5mm ² (DIN 72551-FLR Parts 5 and 6)
968221-1	MQS Clean Body Contact (Female)	0.75mm ² (DIN 72551-FLR Parts 5 and 6)
964282-2	JPT Contact (Female)	0.2—0.5mm ² (DIN 72551-FLR Parts 5 and 6)
964286-2	JPT Contact (Female)	0.5—1.0mm ² (DIN 72551-FLR Parts 5 and 6)
964273-2	JPT Contact (Female)	>1.0—2.5mm ² (DIN 72551-FLR Parts 5 and 6)

Fig.2

1.2.1 Wire Seal (For JPT)

Part Number	Applicable Insulation Diameter (mm)
963294-1	φ 1. 2~2. 1
963293-1	φ 2~2. 7
963292-1	φ 2. 7~3

Fig.3

1.3 Components View

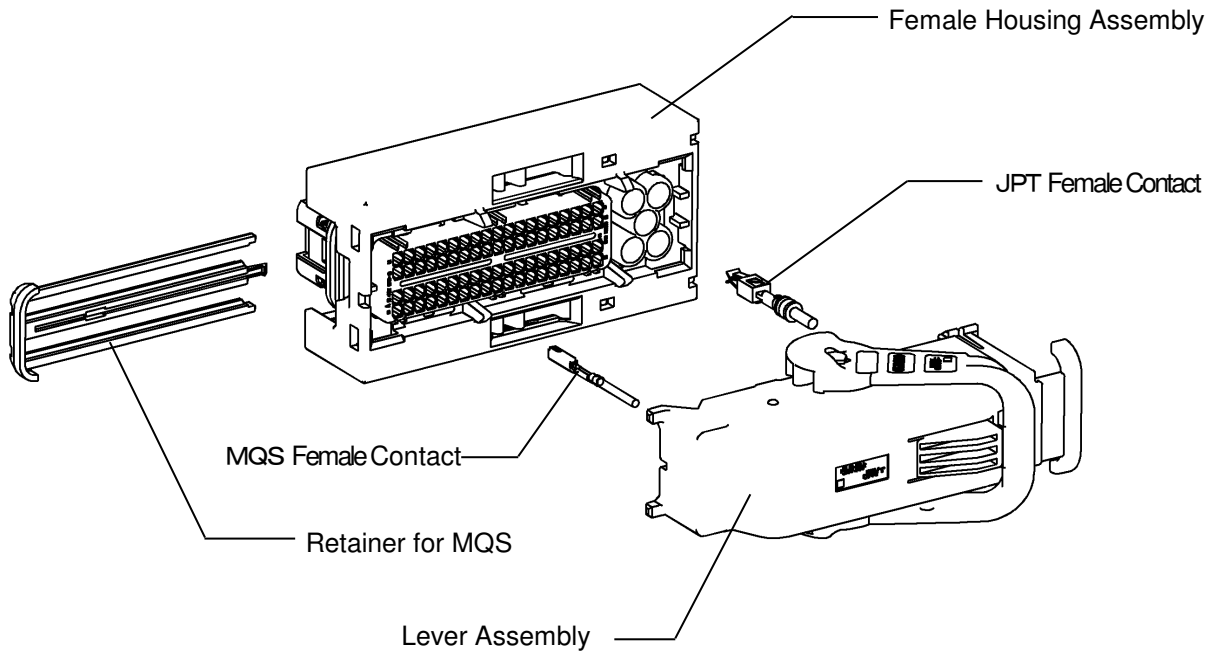

2. CUSTOMER RECEIVING INSPECTION

Tyco conducts inspections according to their quality control regulations to maintain an over all lot control. In addition, the customers should conduct receiving inspections based on the specific customer drawings.

3. STORAGE AND CARRYNG

3.1 Contact

- (1) Avoid receiving or carrying the contact reel in an open area without wrapping it in proper material.
- (2) Do not lift up and carry the contact reel by gripping one the side of the reel, this may result in damage to the reel and contacts before use.

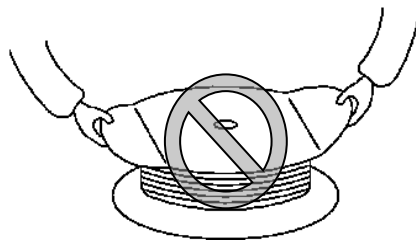

Do not lift up laterally holding one side only.

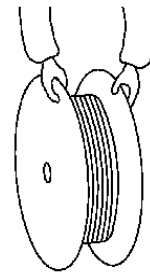

Acceptable

Fig.5

- (3) Avoid storing the contact reel in a moist or dusty place. Stock the reel in a comparatively dry and clean place (5~35°C, 45~85%RH) away from direct sunlight.
- (4) When removing the contact reel from the machine, fasten the end of the contact strip onto the edge of the reel with use of proper string or wire. Fig 6.

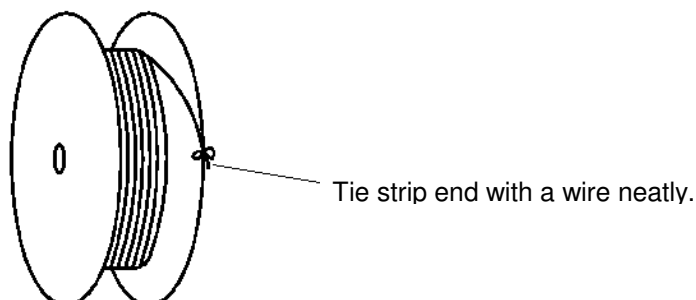

Fig.6

3.2 Housing

- (1) Avoid storing the contact reel in a moist or dusty place. Stock the reel in a comparatively dry and clean place (5~35°C, 45~85%RH) away from direct sunlight.
- (2) Avoid leaving or carrying the housing in an open area without wrapping it in proper material.
- (3) Do not drop or shock the housing when carrying it.

4. CRIMPING OPARATION

Any crimping of contact must be performed by using appropriate Tyco tools according to the applicable Instruction Sheet and Specification.

4.1 Wire

4.1.1 Applicable Wire

See Fig.2 for applicable wire.

4.1.2 Notes for Stripping Wire End

Wire end must be stripped without cut or damage of wire strands.

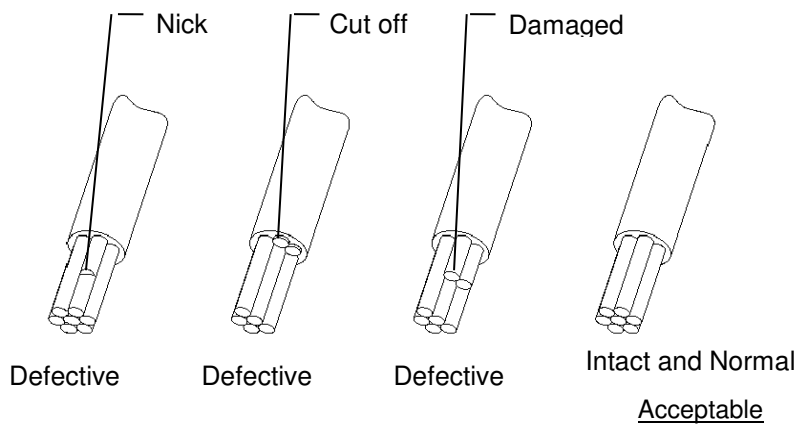

Fig.7

4.2 Operation of Crimping Machine

See following Customer Manual for each contact

MQS Female Contact	412-5022
JPT Female Contact	412-5022

4.3 Crimping Specification

See following Application Specification for each contact

MQS Female Contact	114-18021
JPT Female Contact	114-18050-1

4.4 Storage and Handling of Crimping Products

- (1) Store the products in a clean, dry area cover with proper sheet or paper when placed in an open area until the next day.
- (2) Care should be taken for tangle and deform of contacts in case of the leads should be in bands.
- (3) Do not stack the product so many layers. It makes electrical connection defective and low contact retention force by catch together or by deform causing the weight of themselves.
- (4) Must no hit tip of the contacts to coordinate the bundle. It makes mating or electrical defective.

5. HARNESS MAKING

5.1 Insertion Female Contact into Housing

- (1) Check JPT Retainer is in pre-lock condition. (Par. 5.4) The contact can not be inserted in case of the final lock condition.

Pre-lock Condition

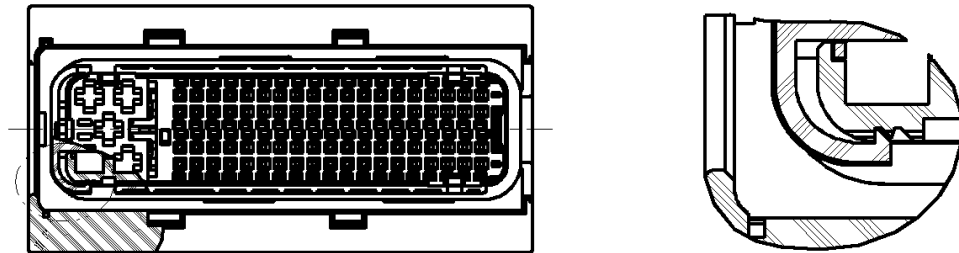

Final Lock Condition

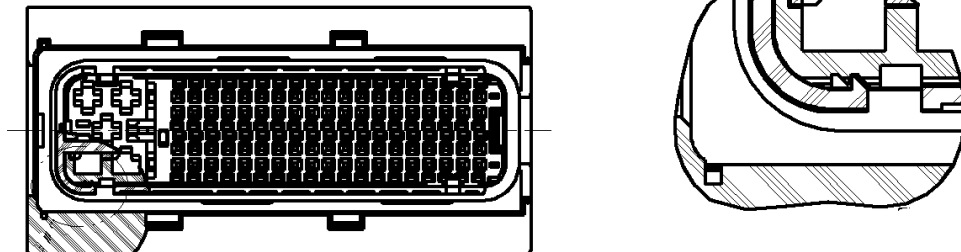

Fig.8

- (2) Insert contacts into the each specific cavity with proper contact direction as shown in Fig. 9.
 Operation is completed when contact is latched and the insertion is stopped.

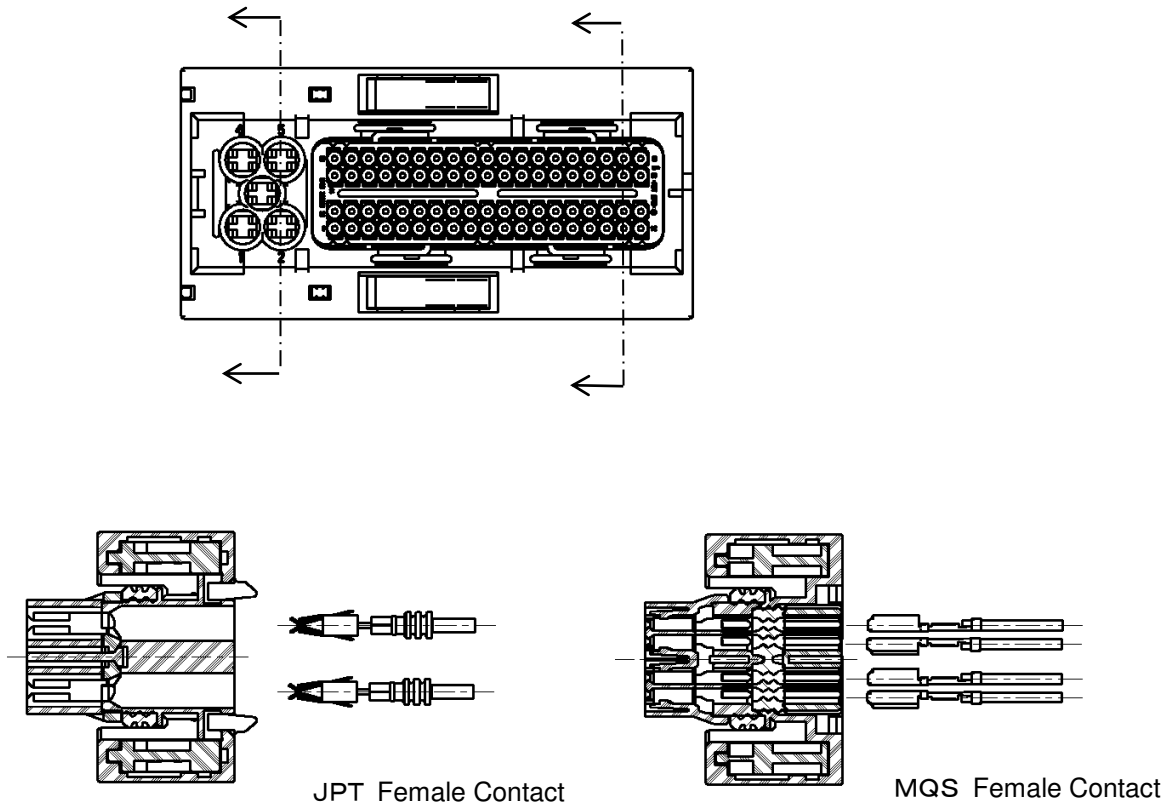

Fig.9

- (3) In addition to above action, confirm no extraction is made by pulling wires with 20N max for MQS contact and with 40N max for JPT contact.

NOTE MQS contact performs higher insertion force than non sealed type connector cause of using family seal device. MQS contact especially requires careful insertion operation specified by above-mentioned (2) and (3).

5.2 Cavity Plug Insertion into Housing

Cavity Plug is required to be inserted into vacant Cavity to maintain sealing capability.

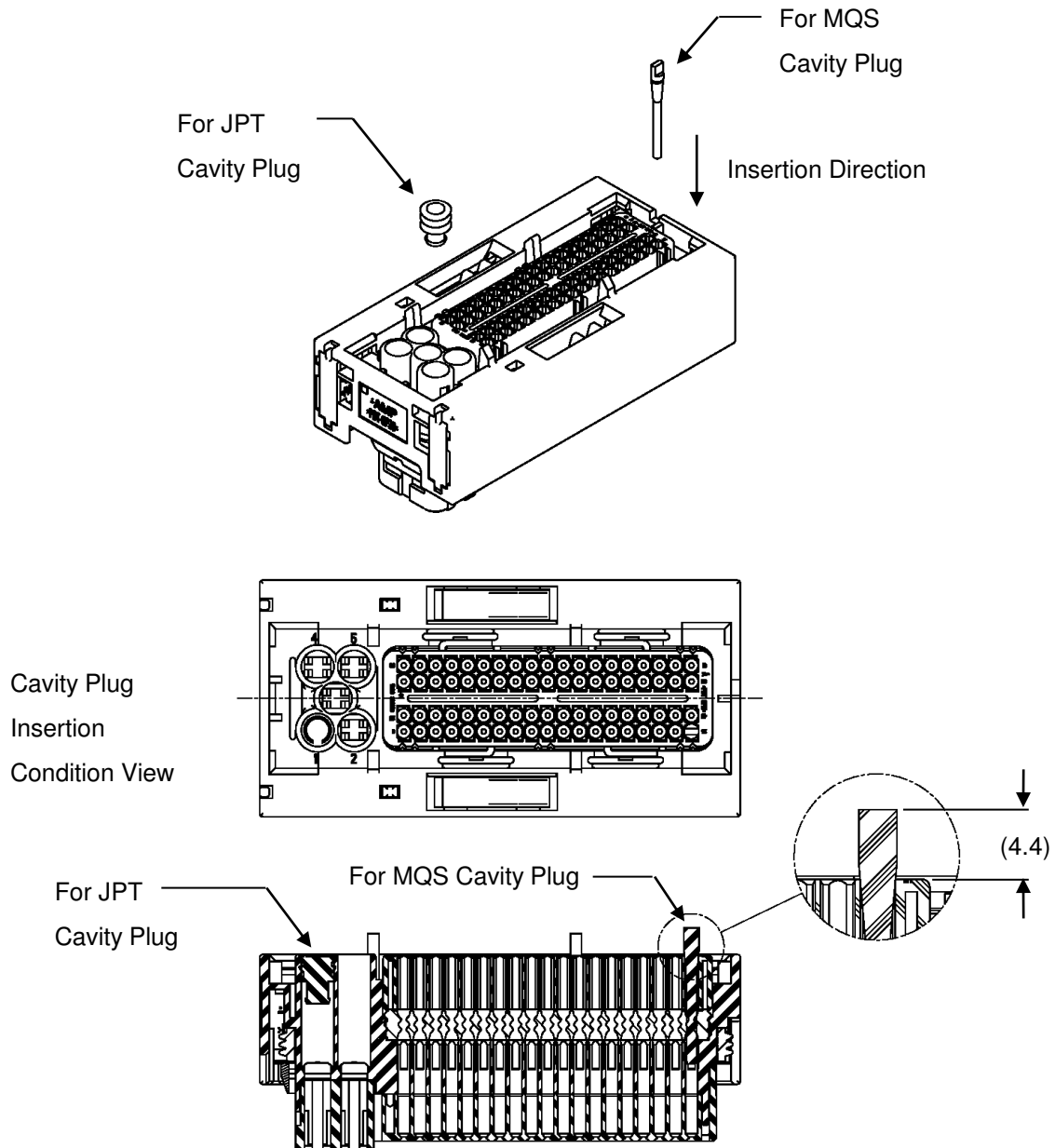

- JPT Cavity Plug

Fully insert into the cavity so that Cavity Plug end is coincident with Housing end.

- MQS Cavity plug

Insert vertically into Housing until Cavity plug is stopped by top surface of cavity.

NOTE Housing deformation or break occurs with insertion too strongly. The operation must be conducted carefully.

5.3 Retainer Final Lock (Secondary Lock)

(1) After all cavities are filled by inserted Contacts or Cavity Plugs properly, insert Retainers into Housing to deep end and complete Final Lock condition.

- MQS Contact Retainer

Before Retainer Insertion

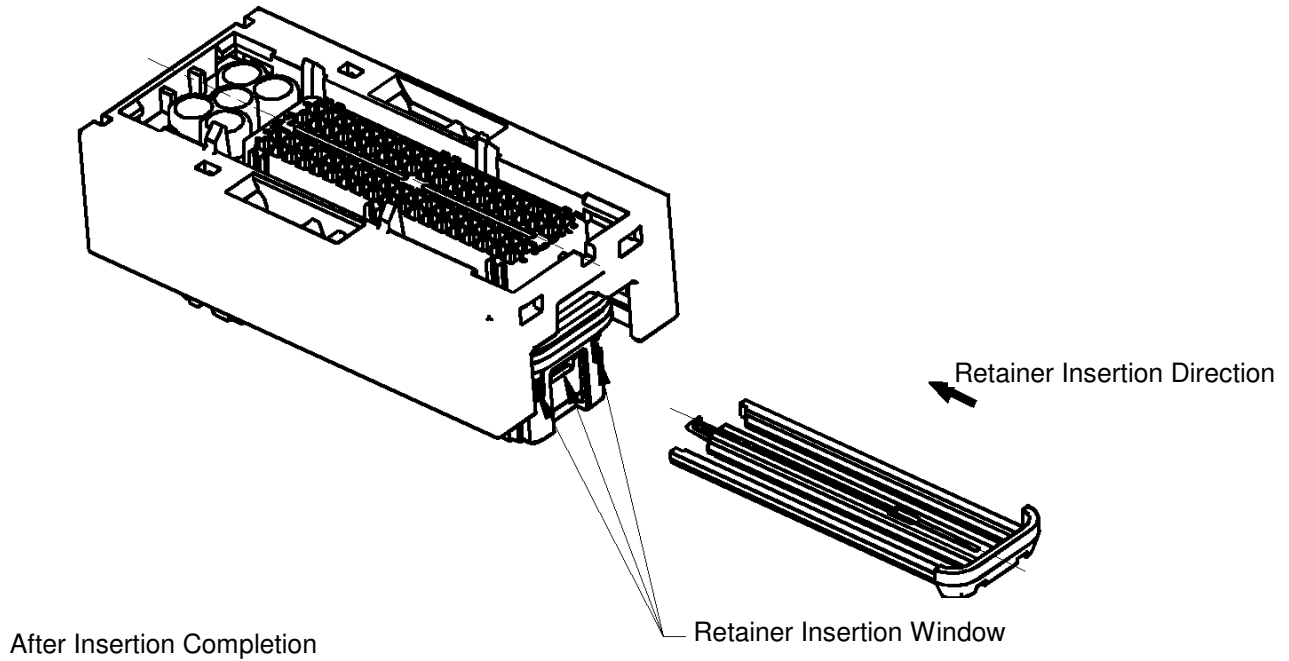

Fig.11

- JPT Contact Retainer

See Fig.8 .

(2) When Retainers can not be inserted, do not operate with force and must find half insertion contact. The half insertion contact prevents the retainers from inserting.

5.4 Retainer Release Procedure

In case of Female Contact insertion or extraction, Retainer is extracted to Pre-Lock condition (see Fig.8) for JPT and is fully extracted for MQS. It is impossible to insert or extract the contacts with Retainer final lock condition.

- (1) Put 1mm blade screw driver on a place for Retainer release.
 - * 1) Put tip of the screw driver on and release final lock on each side of Retainer then move it to Pre-Lock condition.
- (2) Confirm both retainer latches are positioned at Pre-Lock condition after the retainer is pulled approximately 1mm.

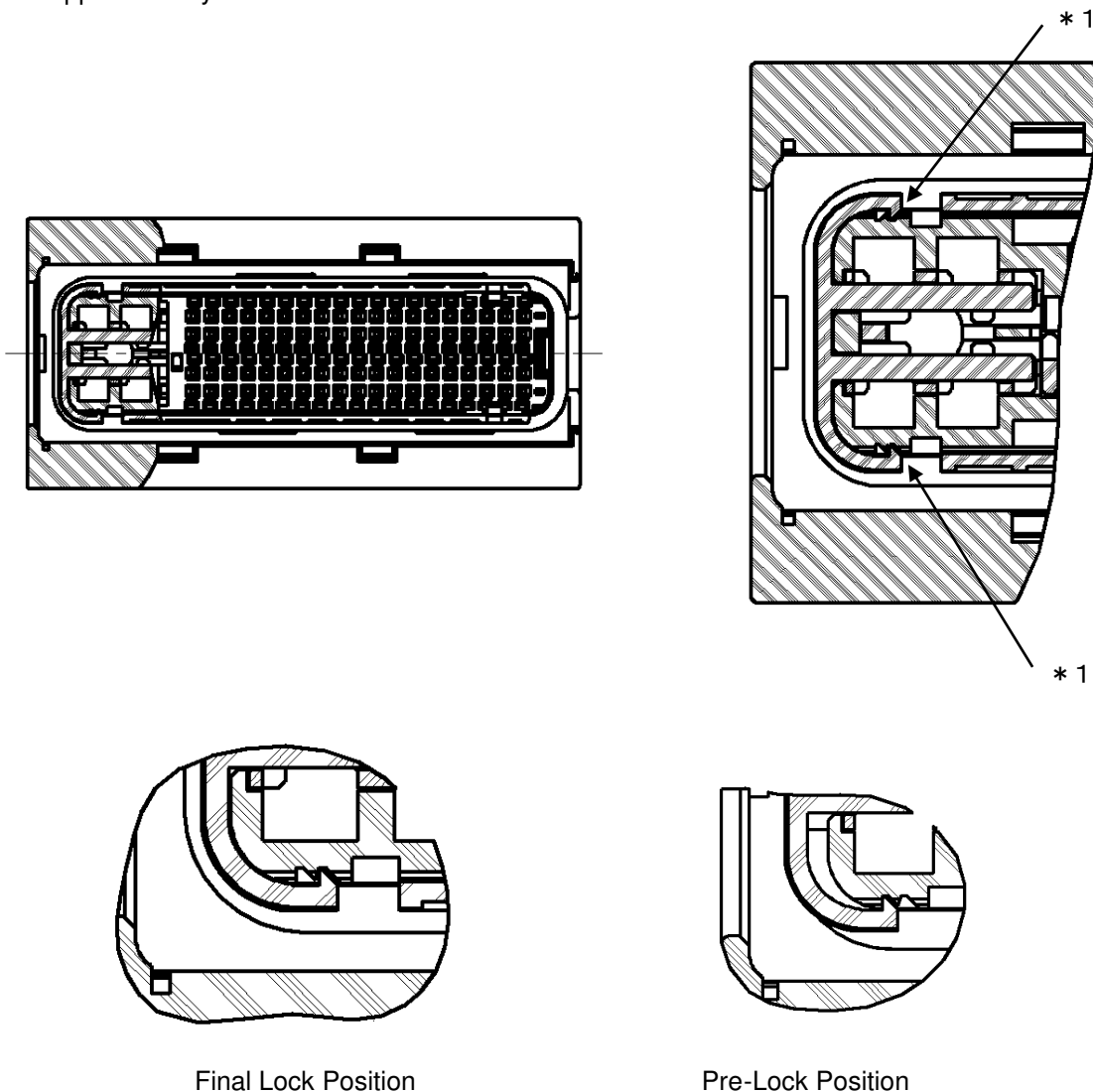

Fig.12

NOTE

Do not pull JPT Retainer beyond the Pre-Lock condition. It causes of breaking the retainer itself.

5.5 Female Contact Extraction

(1) Confirm Retainers are in Pre-Lock condition. In case of Final Lock condition, it is necessary to move it to Pre-Lock condition (see Fig. 5.4). It is impossible to extract the contacts under Final Lock condition.

•MQS Contact

(2) Extract contact with pulling the crimped wire while pressing latch slightly with 1mm blade screw (it makes easier the operation that push the contacts to bottom end of the cavities once before the operation above-mentioned).

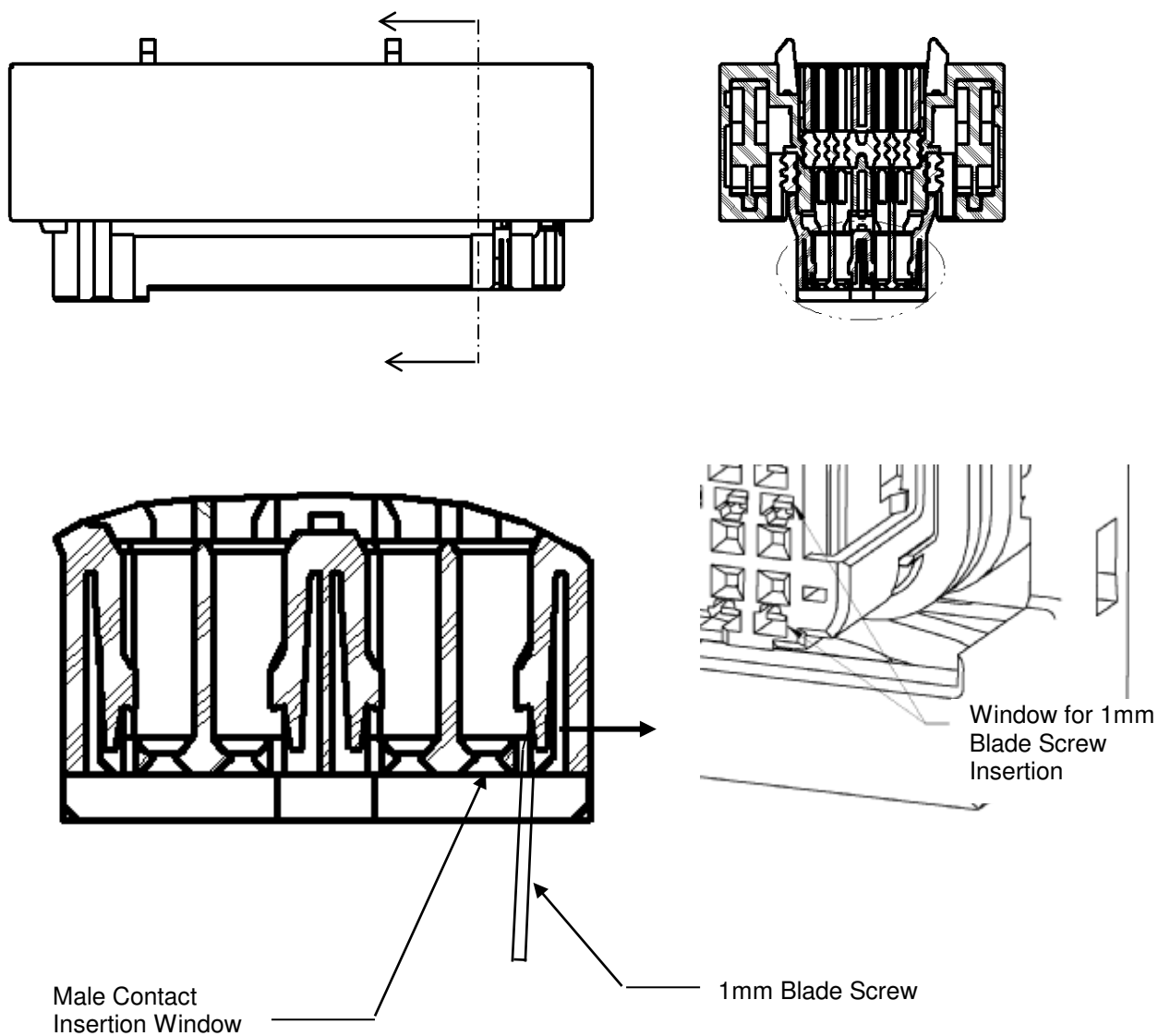

Fig. 13

NOTE

Plug Housing Assembly must be changed new one if seal device is damaged during the extraction operation.

•JPT Contact

- (2) Extract the contact with specified tool inserted into proper hole until stopped at bottom end.
 (It makes operation easier to press the contact to insertion direction once.)

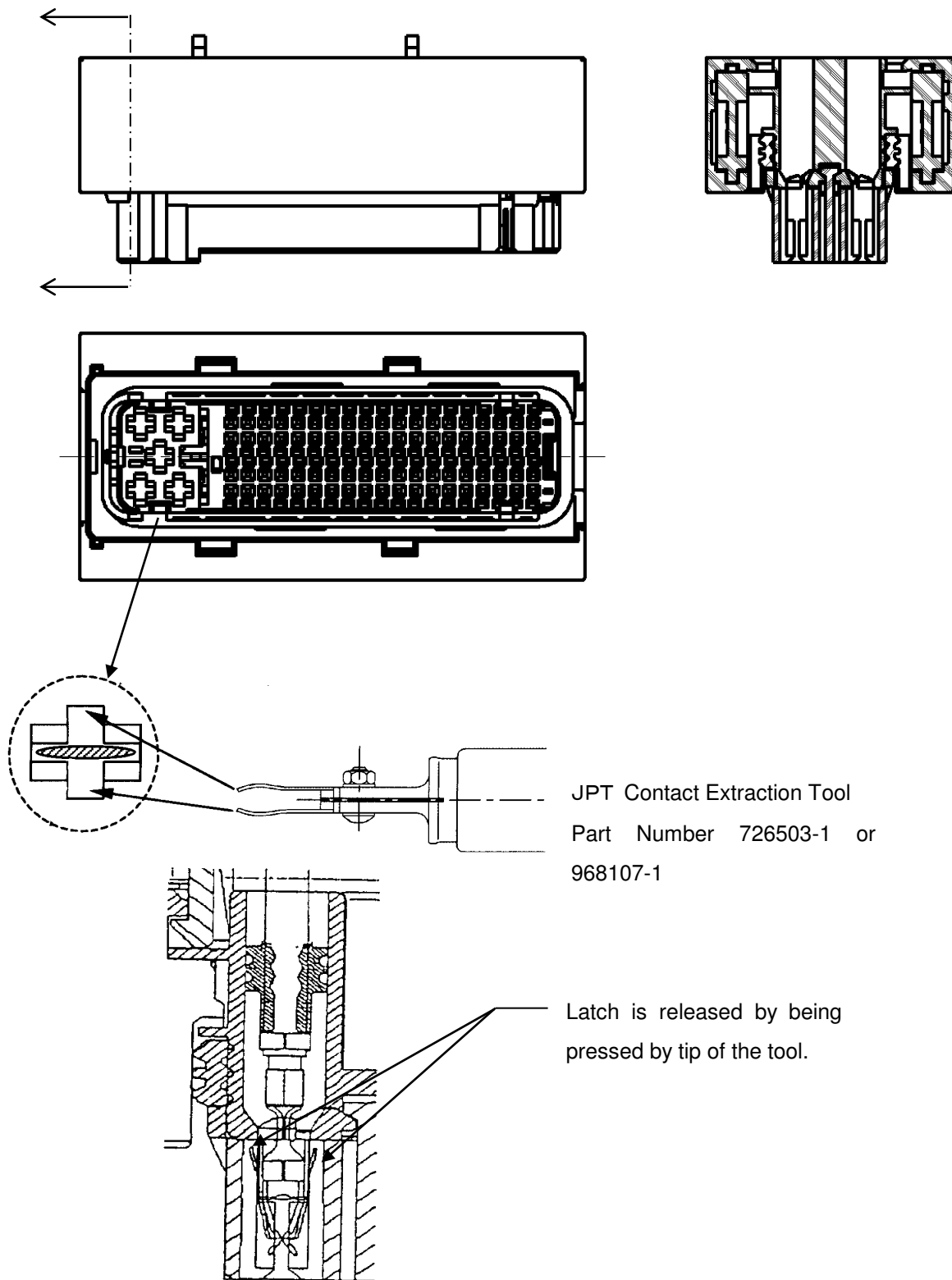

Fig.14



NOTE Do not insert the tool or screw driver into inside of the female contact. In case of the insertion, no reuse is allowed and must be replaced to new female contact.

5.6 Lever Assembly Attach Operation

- (1) Bend wire harness to specified direction.
- (2) Insert the back side lock of the Lever Assembly into hole for latch at Plug Assembly.
- (3) Insert the wire taking out side lock of the Lever Assembly into hole for latch at Plug Assembly.

NOTE There are two types of Lever Assembly for wire direction variation.

TYPE-A : Same direction as JPT Contact side.

(Harness is took out to outside after mating with Male Housing .)

TYPE-B : Same direction as MQS Contact side.

(Harness is took out to inside after mating with Male Housing.)

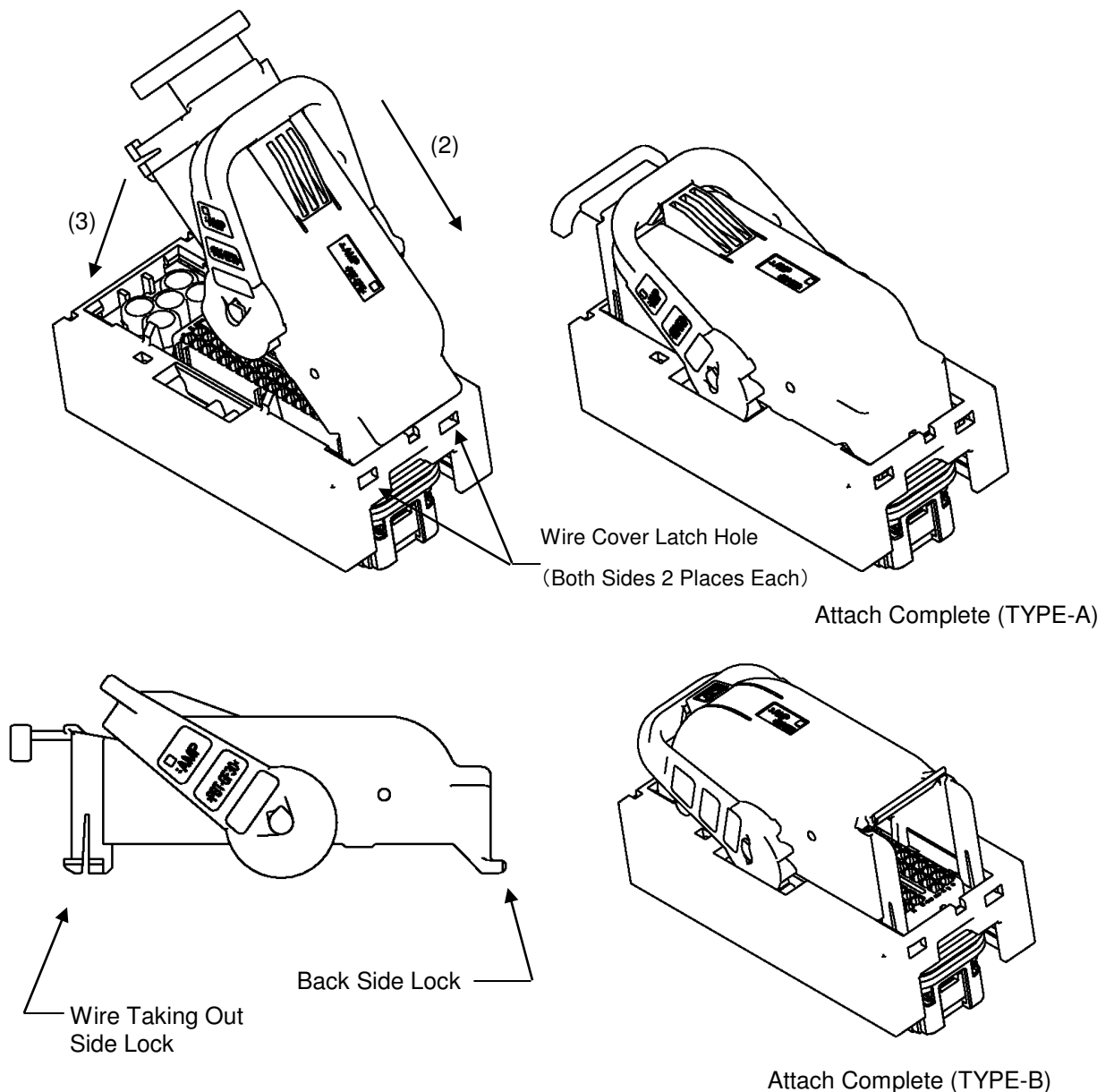

Fig.15

NOTE No improper Wire Cover Attach Operation is allowed. Confirm wires are inside of the Wire Cover neatly.

NOTE Be aware Lever position. The operation should be done with same Lever position as shipping condition. See Fig. 16 for Lever shipping condition.

NOTE Check Slide position. The operation should be made with same Slide position as shipping condition. See Fig. 17 for Slide shipping condition.

81P
TYPE-A

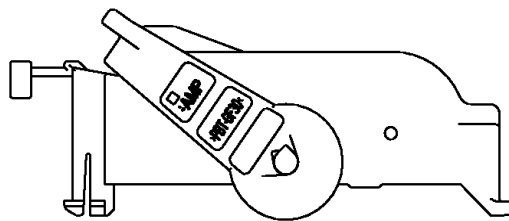

81P
TYPE-B

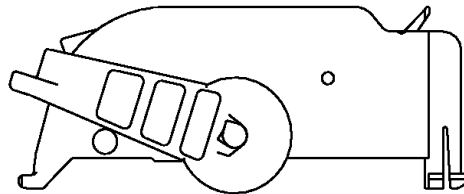

40P

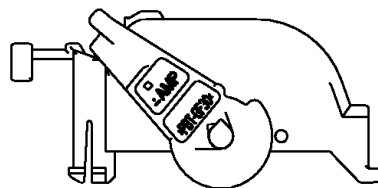

Fig.16

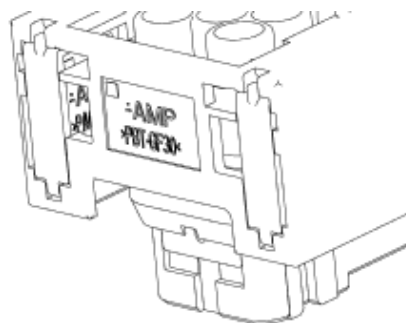

Fig. 17

5.7 Lever Assembly (Harness Cover) Release Operation

- (1) Confirm Lever is in final lock (in shipping condition from Tyco) condition. (See Fig.16)
- (2) Release latch at the tip of Lever Assembly Lock at wire taking out side with specified screw driver being inserted in the hole and pressing. And then take out Lever Assembly after releasing all latching at wire taking out area by pressing the lock to inside.

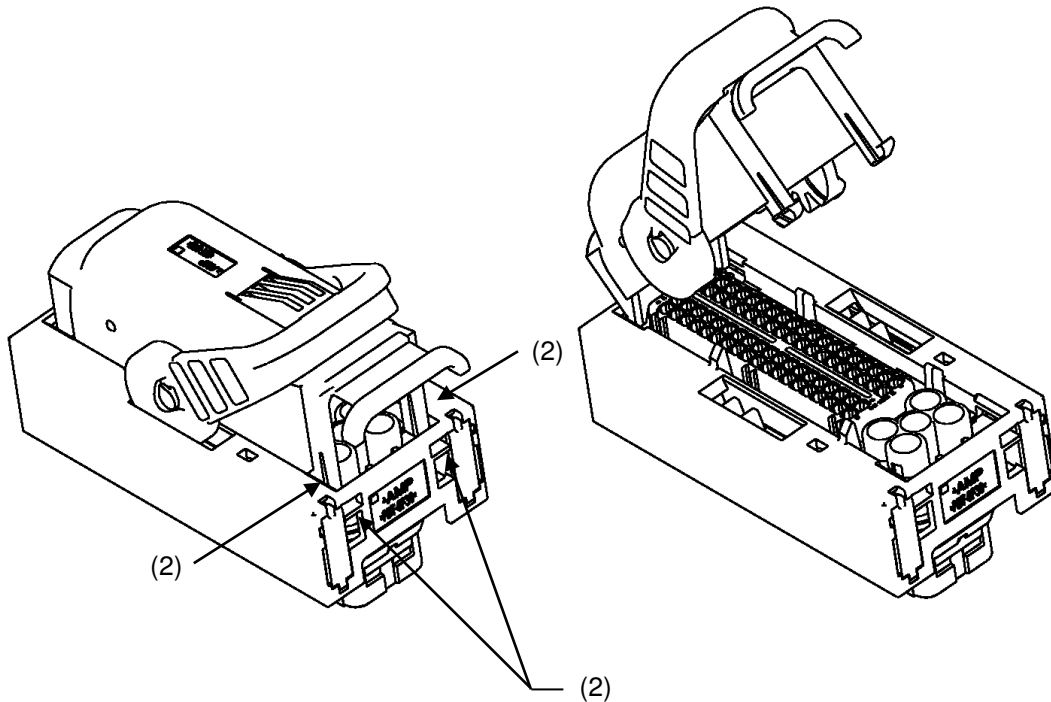

Fig.18

5.8 Wire Harness Control

5.8.1 Handling

Do not apply too much force or shock against connector or harness.

5.8.2 Wire tie up and taping

Wires are tied up at apart from 30mm more from the end of connector. The operation be conducted carefully so that too much force is applied against the wires.

5.8.3 Conductivity Check

(1) Use applicable mating connector or equivalent for conductivity check jig.

(2) Check probe pin must not be inserted inside of female contact.

NOTE Contact must be replaced in case of the prove pin insertion.

(3) Contact Tyco if the check jig is required.

5.8.4 Storage

Store the product dry and clean area. In addition, do not leave the product with exposed condition.

5.8.5 Shipping and Carrying

Use proper package which can prevent product from dust, rain, and etc. And handle carefully.

6. Connector mating and unmating operation

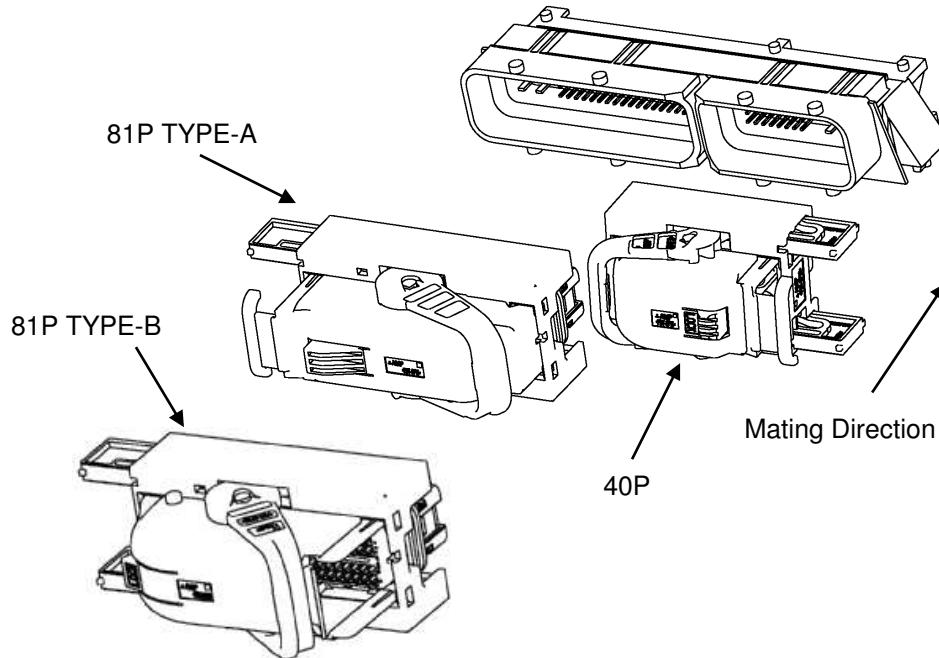

Fig.19

6.1 Connector Mating

- (1) Check contact latching condition, proper wire tie up position, and Retainer is in final lock condition. Retainer must be adjusted to final condition if it is in initial lock condition. (Refer par. 5.3)
- (2) In the next step, check no contact has deformation, discolor, damage, rust and housing has no deformation, crack, breakage, and discolor.

NOTE In case of any trouble is found, replace it to new one.

(3) Lever Position Confirmation

Check Lever is at initial lock position.

Tyco ships the product with Lever at mating complete position. Change it to initial position as shown Fig. 20.

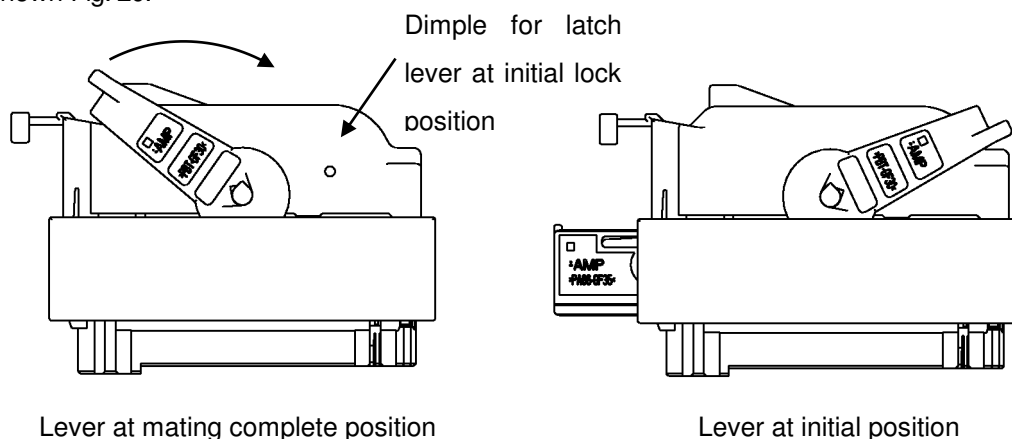

Fig.20

(4) Connector Pre-lock Operation

Insert female housing straight in male housing with specified direction by Fig.19. It is at connector pre-lock condition when the female housing can not be inserted further more.

NOTE At the insertion operation, no Kojiri (apply force except insertion direction) must be made.

NOTE Must not apply too much force against harness or female housing.

NOTE Normal mating operation may not be made if the operation is started under Incomplete pre-lock operation. The operation must be returned to (3).

(5) Make connector be mated.

Operate (rotate) Lever to the final lock position completely.

At this operation, do not handle Lever only but also pressing female housing to male housing.

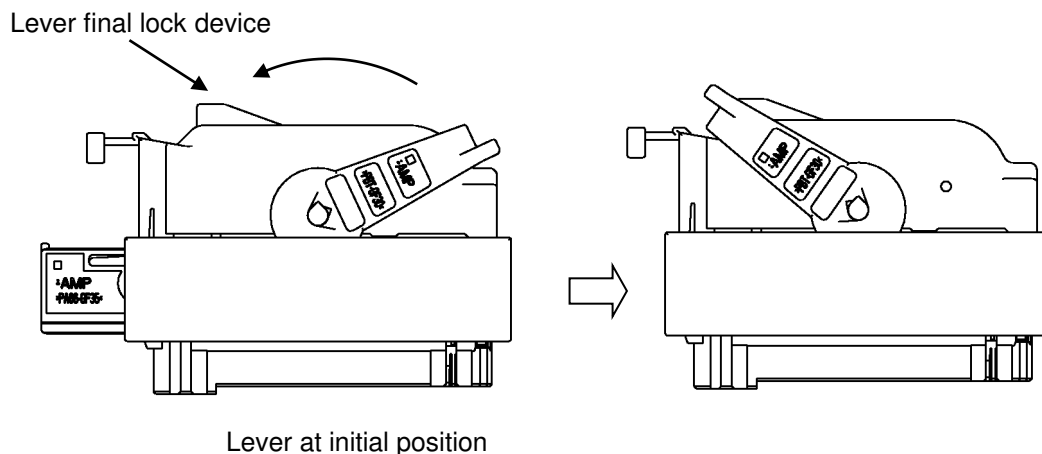

Fig.21

NOTE In case of any unexpected feeling such as double action or unsmooth insertion during the operation, Lever must be adjusted to at initial condition. Operation must be restarted . And then return to (4) operation.

NOTE Both 40 and 81 position female housings must be mated to keep water proof function.

6.2 Connector unmating

- (1) Release Lever lock by pressing down final lock device.
- (2) Lock Lever at initial lock device by operating (rotating) it .
- (3) Release female housing from male housing.