

DO NOT SCALE FROM THIS PRINT

DESIGNED & DIMENSIONED IN MILLIMETERS [INCHES]

SLH-XXX-X.XX-X-D-X-X

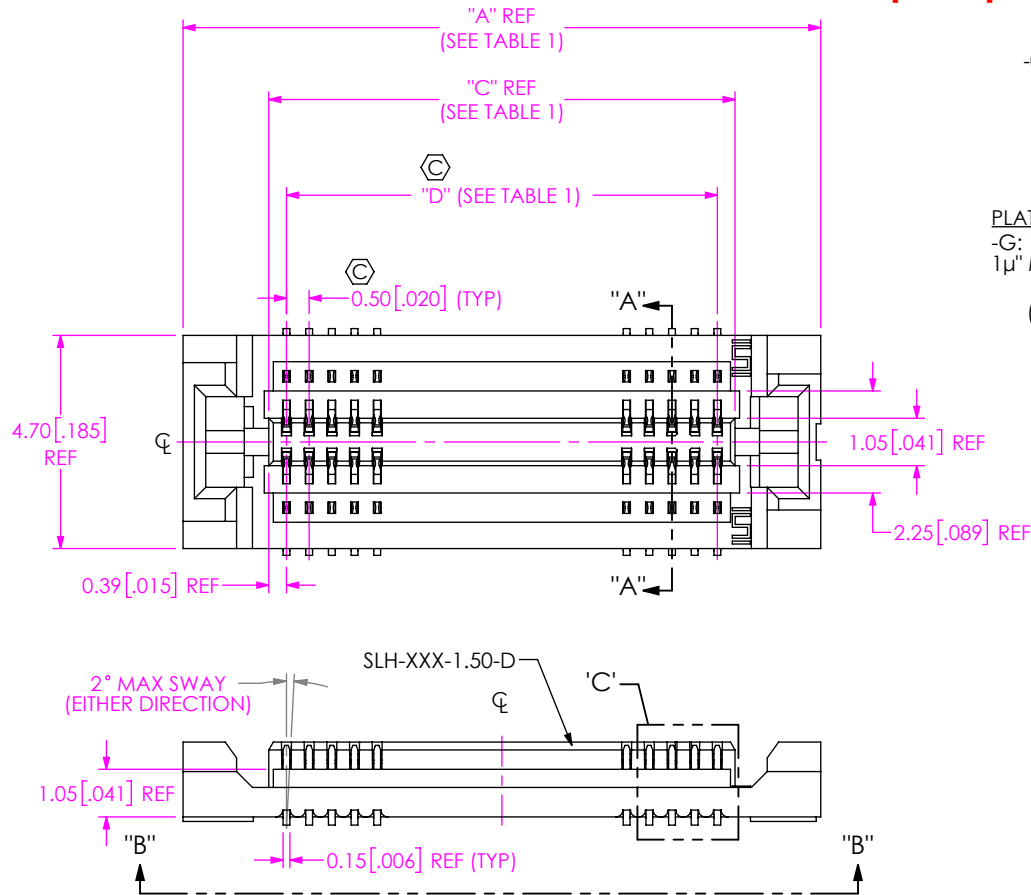

NO OF POSITIONS
-010, -020, -030, -040*
(PER ROW)

LEAD STYLE
-1.50

PLATING SPECIFICATION
-G: 10μ" MIN Au IN CONTACT,
1μ" MIN Au ON TAIL

(*EXISTING CUSTOMER ONLY)

OPTION
-K: K-DOT
(SEE FIG 2, SHT 2)

OPTION
-A: ALIGNMENT PIN
(SEE FIG-3, SHT 3)

ROW SPECIFICATION
-D: DOUBLE ROW

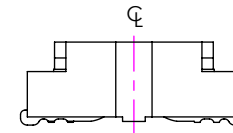
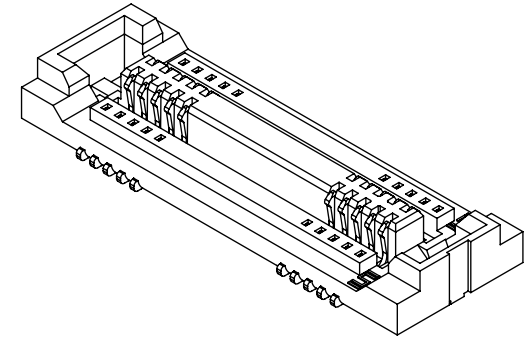

FIG 1
SLH-020-1.50-X-D SHOWN
(SOME CENTER FEATURES NOT SHOWN FOR CLARITY)

NO OF POSITIONS	"A"	"B"	"C"	"D"	"E"	"F"	"G"
-010	9.06 [.357]	8.060 [.3173]	5.28 [.208]	4.500 [.1772]	4.500 [.1772]	3.03 [.119]	6.40 [.252]
-020	14.06 [.554]	13.060 [.5142]	10.28 [.405]	9.500 [.3740]	9.500 [.3740]	5.53 [.218]	11.40 [.449]
-030	19.06 [.750]	18.060 [.7110]	15.28 [.602]	14.500 [.5709]	14.500 [.5709]	8.03 [.316]	16.40 [.646]
-040*	24.06 [.947]	23.060 [.9079]	20.28 [.798]	19.500 [.7677]	19.500 [.7677]	10.53 [.415]	21.40 [.843]

(*EXISTING CUSTOMER ONLY)

NOTES:

- ⊗ REPRESENTS A CRITICAL DIMENSION.
- MINIMUM PUSHOUT FORCE: 1.60N [.36 LB].
- PARTS TO BE PACKAGED IN TAPE AND REEL AS STANDARD.
- PARTS ARE NOT POLARIZED AND WILL NOT BE POLARIZED IN TAPE & REEL PACKAGING.
- FOR QUANTITIES UP TO 49 PIECES, NO LEADER, TRAILER OR REEL WILL BE SUPPLIED FOR QUANTITIES OF 50-124, NO LEADER OR TRAILER WILL BE SUPPLIED.
- CONTACT TIPS NOT TO PROTRUDE ABOVE PLASTIC.
- USE MEASURING FIXTURE AT-2617-803.

UNLESS OTHERWISE SPECIFIED, DIMENSIONS ARE IN MILLIMETERS.
TOLERANCES ARE:
DECIMALS ANGLES
X.X: ±0.3 [.01] 2°
X.XX: ±0.13 [.005]
X.XXX: ±0.051 [.0020]

PROPRIETARY NOTE
THIS DOCUMENT CONTAINS CONFIDENTIAL AND PROPRIETARY INFORMATION AND ALL DESIGN, MANUFACTURING, REPRODUCTION, USE, PATENT RIGHTS AND SALES RIGHTS ARE EXPRESSLY RESERVED BY SAMTEC, INC. THIS DOCUMENT SHALL NOT BE DISCLOSED, IN WHOLE OR PART, TO ANY UNAUTHORIZED PERSON OR ENTITY NOR REPRODUCED, TRANSFERRED OR INCORPORATED IN ANY OTHER PROJECT IN ANY MANNER WITHOUT THE EXPRESS WRITTEN CONSENT OF SAMTEC, INC.

MATERIAL: DO NOT SCALE DRAWING SHEET SCALE: 6:1
INSULATOR: LCP, COLOR: BLACK
CONTACT: COPPER ALLOY



520 PARK EAST BLVD, NEW ALBANY, IN 47150
PHONE: 812-944-6733 FAX: 812-948-5047
e-Mail: info@SAMTEC.com code 53322

DESCRIPTION: SLH SOCKET ASSEMBLY
DWG. NO. SLH-XXX-X.XX-X-D-X-X
BY: JERRY SU 10/23/2014 SHEET 1 OF 3

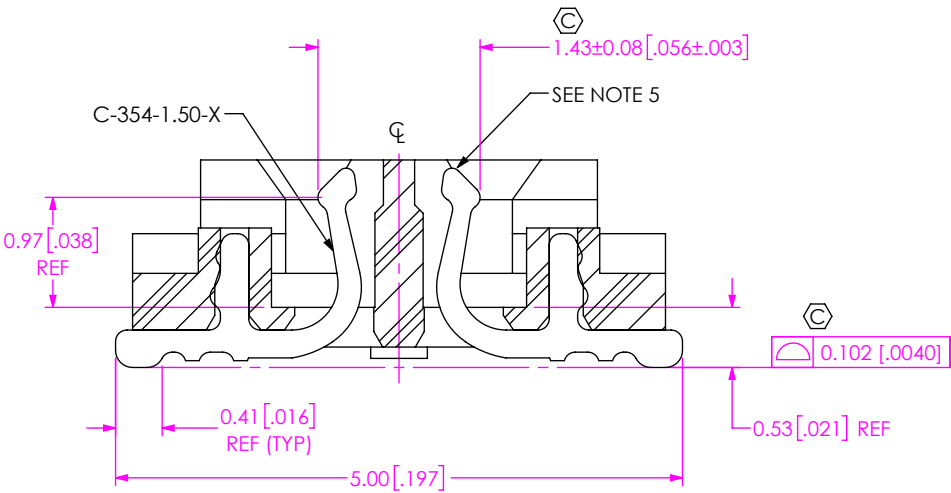

SECTION "A"-
SCALE 15:1

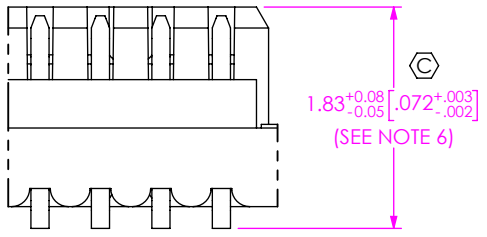

DETAIL 'C'
SCALE 16:1

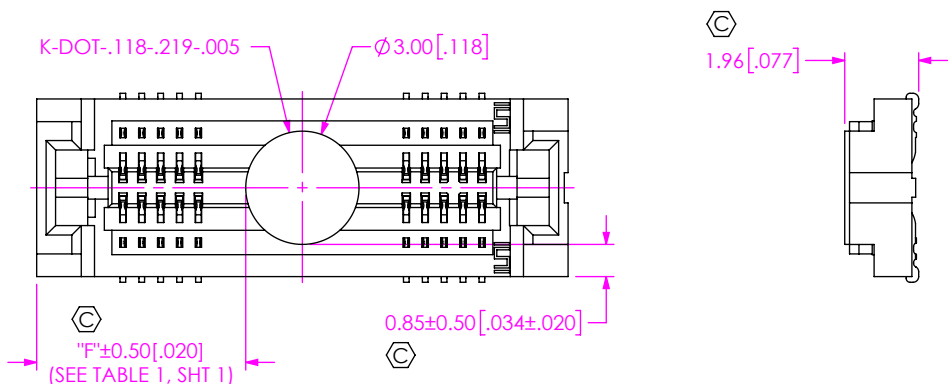
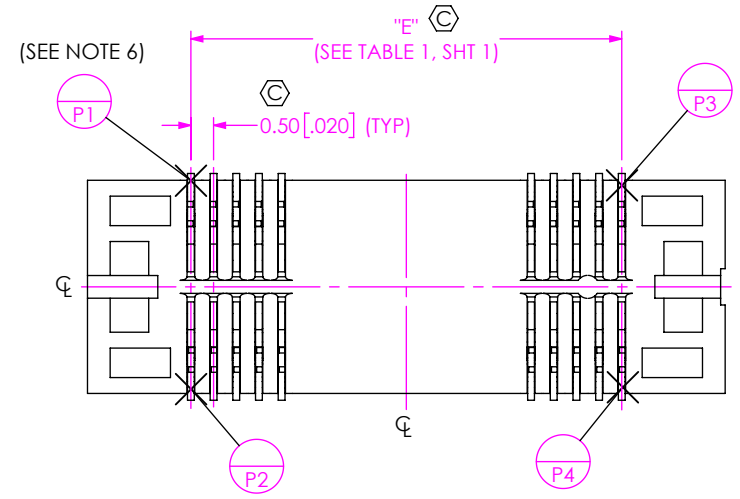

FIG 2
SLH-020-1.50-X-D-K SHOWN
(DIFFERENT AS SHOWN, OTHERWISE SAME AS FIG 1)
(SOME CENTER FEATURES NOT SHOWN FOR CLARITY)

F:\DWG\MISC\MKTG\SLH-XXX-X.XX-X-D-X-X-MKT.SLDDRW

PROPRIETARY NOTE
THIS DOCUMENT CONTAINS CONFIDENTIAL AND PROPRIETARY INFORMATION AND ALL DESIGN, MANUFACTURING, REPRODUCTION, USE, PATENT RIGHTS AND SALES RIGHTS ARE EXPRESSLY RESERVED BY SAMTEC, INC. THIS DOCUMENT SHALL NOT BE DISCLOSED, IN WHOLE OR PART, TO ANY UNAUTHORIZED PERSON OR ENTITY NOR REPRODUCED, TRANSFERRED OR INCORPORATED IN ANY OTHER PROJECT IN ANY MANNER WITHOUT THE EXPRESS WRITTEN CONSENT OF SAMTEC, INC.

DO NOT SCALE DRAWING
SHEET SCALE: 2:1

samtec
520 PARK EAST BLVD, NEW ALBANY, IN 47150
PHONE: 812-944-6733 FAX: 812-948-5047
e-Mail info@SAMTEC.com code 55322

DESCRIPTION: SLH SOCKET ASSEMBLY

DWG. NO. SLH-XXX-X.XX-X-D-X-X

BY: JERRY SU 10/23/2014 SHEET 2 OF 3

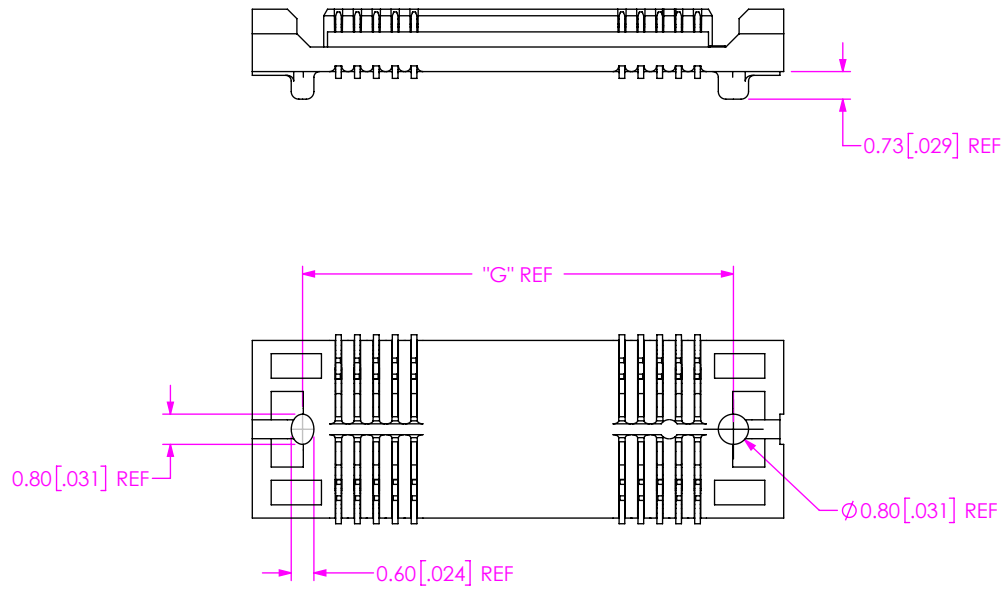

FIG 3
ALIGNMENT PIN DETAIL
SLH-020-1.50-X-D-A SHOWN
(SOME CENTER FEATURES NOT SHOWN FOR CLARITY)

• PROPRIETARY NOTE •
THIS DOCUMENT CONTAINS CONFIDENTIAL AND PROPRIETARY INFORMATION AND ALL DESIGN, MANUFACTURING, REPRODUCTION, USE, PATENT RIGHTS AND SALES RIGHTS ARE EXPRESSLY RESERVED BY SAMTEC, INC. THIS DOCUMENT SHALL NOT BE DISCLOSED, IN WHOLE OR PART, TO ANY UNAUTHORIZED PERSON OR ENTITY NOR REPRODUCED, TRANSFERRED OR INCORPORATED IN ANY OTHER PROJECT IN ANY MANNER WITHOUT THE EXPRESS WRITTEN CONSENT OF SAMTEC, INC.



520 PARK EAST BLVD, NEW ALBANY, IN 47150
PHONE: 812-944-6733 FAX: 812-948-5047
e-Mail info@SAMTEC.com code 55322

DO NOT SCALE DRAWING

SHEET SCALE: 5:1

DESCRIPTION: SLH SOCKET ASSEMBLY

DWG. NO. SLH-XXX-X.XX-X-D-X-X

BY: JERRY SU 10/23/2014 SHEET 3 OF 3