

DO NOT SCALE FROM THIS PRINT

TSSH-1XX-01-XXX-DH-XX

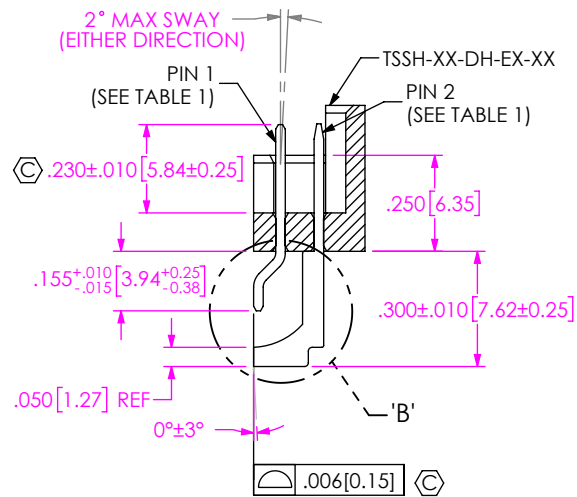

SECTION "A"- "A"

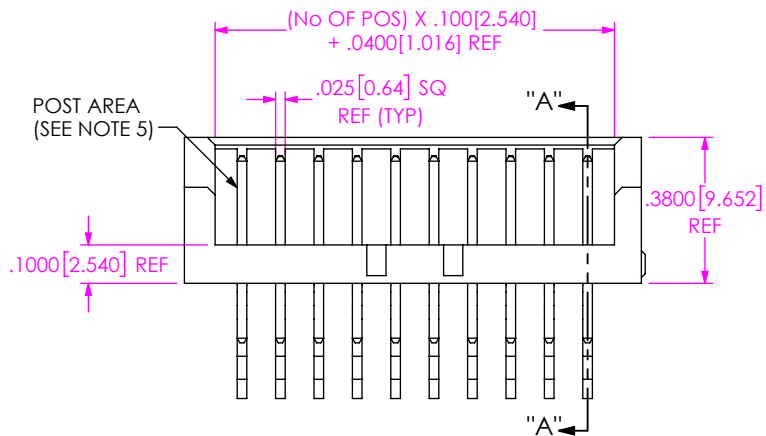
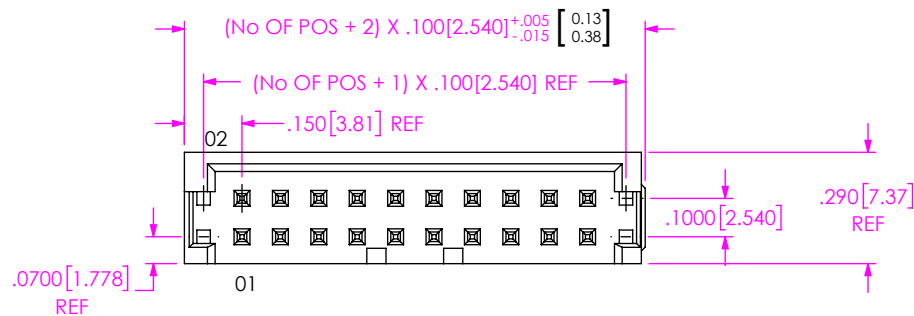
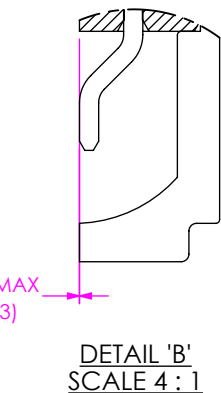

$\text{C} \ .0030 [0.076]$ MAX (SEE SHEET 3)

FIG 1
 TSSH-110-01-XXX-DH SHOWN

No OF POSITIONS
 -02 THRU -34
 LEAD STYLE
 -01

OPTION
 -A: ALIGNMENT PIN (MOLDED) (SEE FIG 2, SHEET 2)
 -TR: TAPE & REEL
 -P: PICK AND PLACE PAD (5 POS MIN) (USE PPP-18) (SEE FIG 3, SHEET 2)

ROW OPTION
 -DH: DOUBLE HORIZONTAL (USE TSSH-XX-DH-ES-XX-X)

PLATING SPECIFICATION (SEE TABLE 1)

- T: MATTE TIN CONTACT AND TAIL
- S: SELECTIVE, 30 Au/50 Ni ON CONTACT, MATTE TIN TAIL
- L: LIGHT SELECTIVE, 10 Au/50 Ni ON CONTACT, MATTE TIN TAIL
- F: FLASH SELECTIVE, 3 Au/50 Ni ON CONTACT, MATTE TIN TAIL
- H: HEAVY GOLD, 30 Au/50 Ni ON CONTACT, 3 Au/50Ni MIN ON TAIL
- TL: TIN/LEAD (90/10±5%) CONTACT AND TAIL
- STL: SELECTIVE, 30 Au/50 Ni ON CONTACT, TIN/LEAD (90/10±5%) TAIL
- TM: MATTE TIM CONTACT AND TAIL
- LM: LIGHT SELECTIVE, 10 Au/50 Ni ON CONTACT, MATTE TIN TAIL
- SM: SELECTIVE, 30 Au/50 Ni ON CONTACT, MATTE TIN TAIL
- FM: FLASH SELECTIVE, 3 Au/50 Ni ON CONTACT, MATTE TIN TAIL

PLATING STYLE	LEAD STYLE	ROW OPTION	PIN 1	PIN 2	
				"A"	"B"
-T	-01	-DH	T-1S6-22-T-2	T-1S35-01-T-2	T-1S35-02-T-2
-STL	-01	-DH	T-1S6-22-STL-2	T-1S35-01-STL-2	T-1S35-02-STL-2
-LM	-01	-DH	T-1S6-22-L-2	T-1S35-01-L-2	T-1S35-02-L-2

FOR OTHER PLATING OPTIONS, REFER TO T-1S6-XX-XX-2 AND T-1S35-XX-XXX-2 COMPONENT DRAWINGS

NOTES:

1. C REPRESENTS A CRITICAL DIMENSION.
2. SEE SHEET 3 FOR FLUSH SPECIFICATIONS.
3. MAXIMUM FLASH ALLOWED: $.010 [0.25]$
4. MINIMUM PUSHOUT FORCE: 1.5 LB.
5. NO BANDOLIER MARKS ARE ALLOWED IN THE POST AREA.
6. TUBE PLUG TO BE LOCATED IN THE BODY AREA, NOT THE TAIL AREA.

UNLESS OTHERWISE SPECIFIED, DIMENSIONS ARE IN INCHES. TOLERANCES ARE:
 DECIMALS ANGLES
 .XX: $\pm .01 [0.3]$
 .XXX: $\pm .005 [0.13]$
 .XXXX: $\pm .0020 [0.051]$

PROPRIETARY NOTE
 THIS DOCUMENT CONTAINS CONFIDENTIAL AND PROPRIETARY INFORMATION AND ALL DESIGN, MANUFACTURING, REPRODUCTION, USE, PATENT RIGHTS AND SALES RIGHTS ARE EXPRESSLY RESERVED BY SAMTEC, INC. THIS DOCUMENT SHALL NOT BE DISCLOSED, IN WHOLE OR PART, TO ANY UNAUTHORIZED PERSON OR ENTITY NOR REPRODUCED, TRANSFERRED OR INCORPORATED IN ANY OTHER PROJECT IN ANY MANNER WITHOUT THE EXPRESS WRITTEN CONSENT OF SAMTEC, INC.



520 PARK EAST BLVD, NEW ALBANY, IN 47150
 PHONE: 812-944-6733 FAX: 812-948-5047
 e-Mail info@SAMTEC.com code 55322

MATERIAL: DO NOT SCALE DRAWING SHEET SCALE: 2:1
 INSULATOR: LCP, UL 94-0, COLOR: BLACK

DESCRIPTION:
 .100 x .100 TERMINAL STRIP w MOLDED END SHROUDS

DWG. NO. TSSH-1XX-01-XXX-DH-XX

BY: BURRE 10/10/1998 SHEET 1 OF 3

PACKAGING TABLE		
ROW OPTION	PACKAGING TUBE	PLUG
-DH	PT-1-24-01-44	TP-07

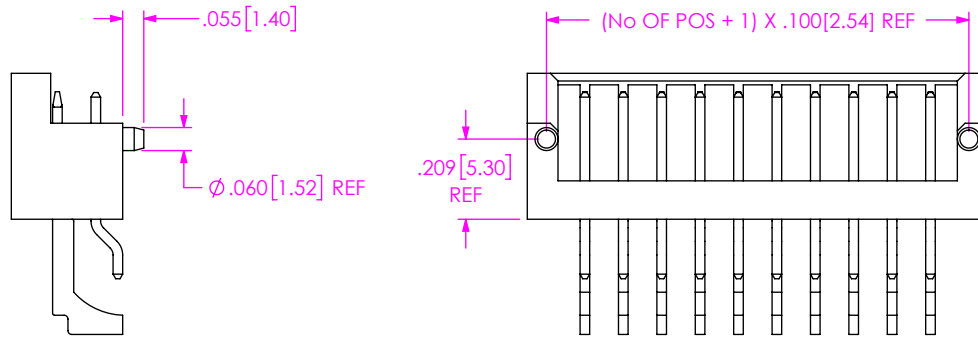
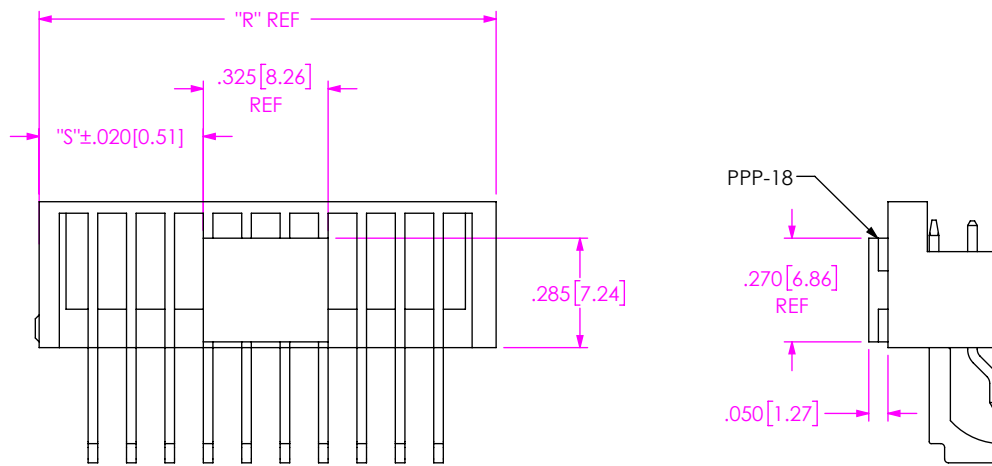
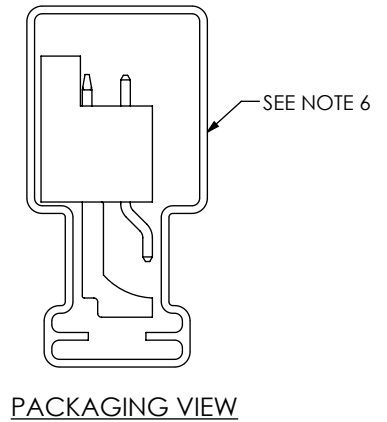

FIG 2
-A: ALIGNMENT PIN OPTION
TSSH-110-01-XXX-DH-A SHOWN



FOR ODD POSITION PART
"R" = (No OF POS + 2) x .100 [2.54]
"S" = (("R" - .325 [8.26]) / 2)

FOR EVEN POSITION PART
"R" = (No OF POS + 1) x .100 [2.54]
"S" = (("R" - .325 [8.26]) / 2)

FIG 3
-P: PICK AND PLACE PAD OPTION
TSSH-110-01-XXX-DH-P SHOWN
(5 POS MIN)

PROPRIETARY NOTE
THIS DOCUMENT CONTAINS CONFIDENTIAL AND PROPRIETARY INFORMATION AND ALL DESIGN, MANUFACTURING, REPRODUCTION, USE, PATENT RIGHTS AND SALES RIGHTS ARE EXPRESSLY RESERVED BY SAMTEC, INC. THIS DOCUMENT SHALL NOT BE DISCLOSED, IN WHOLE OR PART, TO ANY UNAUTHORIZED PERSON OR ENTITY NOR REPRODUCED, TRANSFERRED OR INCORPORATED IN ANY OTHER PROJECT IN ANY MANNER WITHOUT THE EXPRESS WRITTEN CONSENT OF SAMTEC, INC.

samtec
520 PARK EAST BLVD., NEW ALBANY, IN 47150
PHONE: 812-944-6733 FAX: 812-948-5047
e-Mail info@SAMTEC.com code 55322

SHEET SCALE: 2:1

DESCRIPTION:
.100 x .100 TERMINAL STRIP w MOLDED END SHROUDS

DWG. NO.
TSSH-1XX-01-XXX-DH-XX

BY: BURREN 10/10/1998 SHEET 2 OF 3

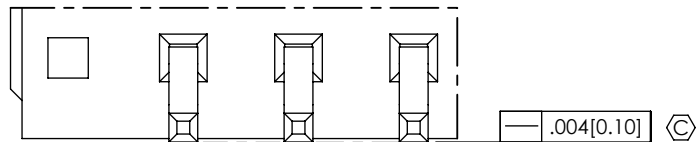

DETAIL 'C'
SCALE 6 : 1

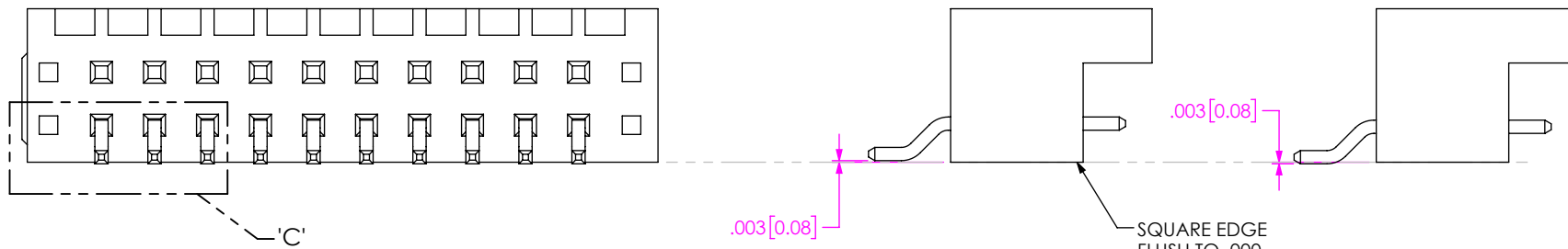

ROW 1 COPLANARITY DIAGRAM

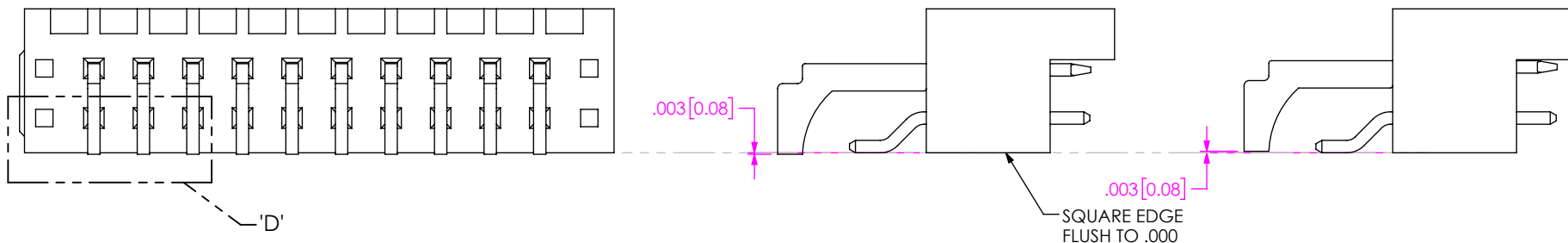

ROW 2 COPLANARITY DIAGRAM

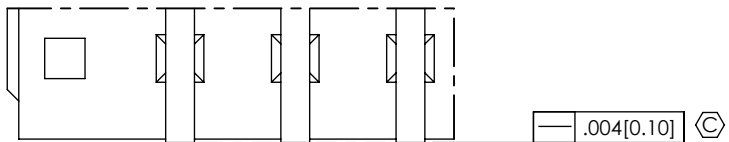

DETAIL 'D'
SCALE 6 : 1

PROPRIETARY NOTE
 * THIS DOCUMENT CONTAINS CONFIDENTIAL AND PROPRIETARY INFORMATION AND ALL DESIGN, MANUFACTURING, REPRODUCTION, USE, PATENT RIGHTS AND SALES RIGHTS ARE EXPRESSLY RESERVED BY SAMTEC, INC. THIS DOCUMENT SHALL NOT BE DISCLOSED, IN WHOLE OR PART, TO ANY UNAUTHORIZED PERSON OR ENTITY NOR REPRODUCED, TRANSFERRED OR INCORPORATED IN ANY OTHER PROJECT IN ANY MANNER WITHOUT THE EXPRESS WRITTEN CONSENT OF SAMTEC, INC. *



520 PARK EAST BLVD, NEW ALBANY, IN 47150
 PHONE: 812-944-6733 FAX: 812-948-5047
 e-Mail info@SAMTEC.com code 55322

SHEET SCALE: 3:1

DESCRIPTION:
 .100 x .100 TERMINAL STRIP w MOLDED END SHROUDS

DWG. NO.
TSSH-1XX-01-XXX-DH-XX

BY: BURRES 10/10/1998 SHEET 3 OF 3