

THIS DRAWING IS UNPUBLISHED. RELEASED FOR PUBLICATION  
 © COPYRIGHT copyright.d8te- ALL RIGHTS RESERVED.

REVISIONS				
P	LTR	DESCRIPTION	DATE	APVD
A		RELEASED FOR PRODUCTION	23OCT2017	RK PO
B		REVISED PER ECR-18-017215	29NOV2018	SR MZ

NOTES:

- 1 LID NOT ASSEMBLED WITH LOWER PART. ENCLOSED LOOSELY
- 2 FLAP NOT ASSEMBLED WITH LOWER PART. ENCLOSED LOOSELY
- 3 PART NUMBER.
- 4 PRODUCTION DATE (YYMMDD)
- 5 MANUFACTURING LOCATION CODE.
- 6 OMEGA CLIP AS LOOSE PIECE IN BOX, PRODUCT SPEC. 108-94176
- 7 MODEL CODE ACCORDING TE-SPEC. 404-74000-1
- 8 CONSECUTIVE SERIAL NUMBER
- 9 TEST EQUIPMENT NUMBER
- 10 DIODES WELDED ON CONTACT RAIL
- 11. MUST COMPLY WITH DIRECTIVE 2002/95/EC (ROHS).
- 12. THIS PRODUCT HAS NOT COMPLETED VALIDATION TESTING.

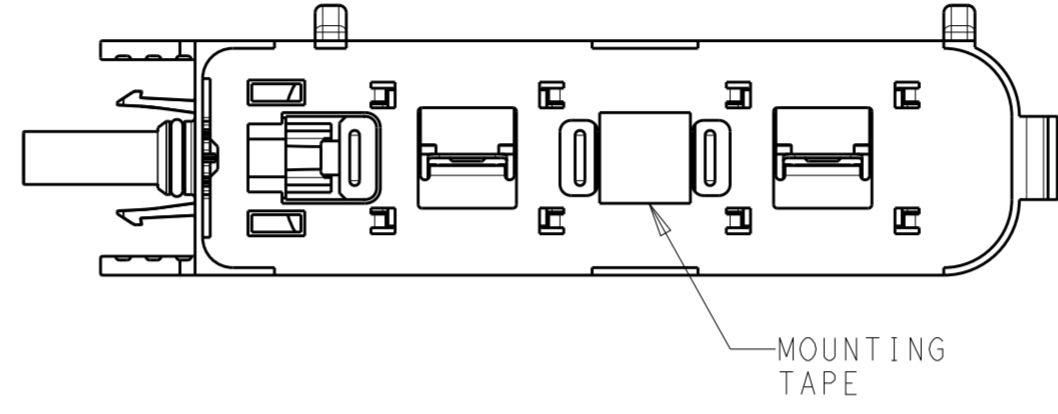

BOTTOM VIEW OF TYPICAL ASSEMBLY WHEN MOUNTING TAPE IS APPLIED

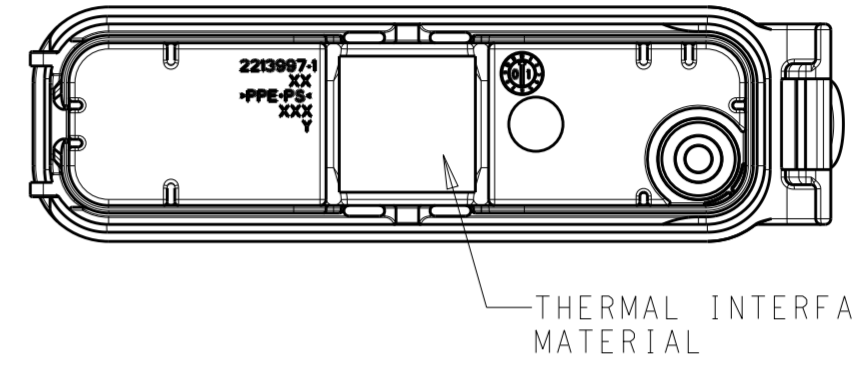

BOTTOM VIEW OF LID SUBASSEMBLY WHEN THERMAL INTERFACE MATERIAL IS APPLIED

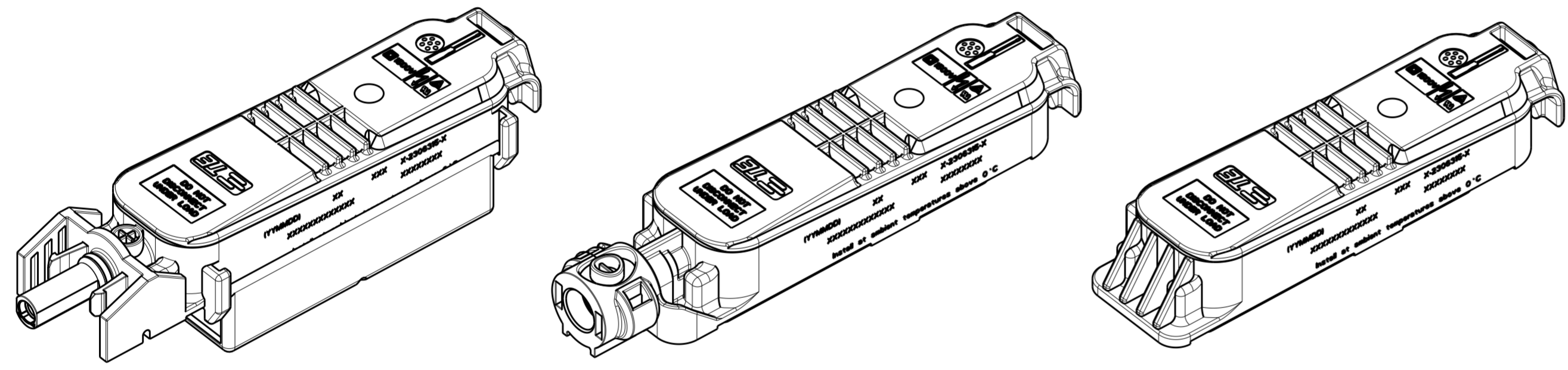

BLACK	PPE+PS	EDGE FLAP	12/2
TIN OVER NICKEL	COPPER ALLOY	INTERFACE CONTACT-SOCKET	11
TIN OVER NICKEL	COPPER ALLOY	INTERFACE CONTACT-PIN	10
-	-	THERMAL INTERFACE MATERIAL	9
-	-	BYPASS DIODE: TYPE SL2020A	8
GRAY	PPE+PS	MEMBRANE RETAINER	7
-	-	MEMBRANE VENT	6
PLAIN	STAINLESS STEEL	OMEGA CLIP	5/6
TIN	COPPER ALLOY	CONTACT RAIL	4
BLACK	PPE+PS	BOX, LOWER HOUSING	3
RED	SILICONE	O-RING SEAL	2
BLACK	PPE+PS	BOX, LID	1/1
COLOR/FINISH	MATERIAL	DESCRIPTION	ITEM NO.

PVEDGE2GGA1V_1	36.0	NORTH/SOUTH	YES	YES	3-2306316-5	
PVEDGE2DGA1V_1	55.2	NORTH/SOUTH	YES	YES	3-2306316-2	
PVEDGE2FGA1V_1	58.7	NORTH/SOUTH	YES	YES	3-2306316-1	
PVEDGE2GGA1V_1	36.0	NORTH/SOUTH	NO	YES	2-2306316-5	
PVEDGE2DGA1V_1	55.2	NORTH/SOUTH	NO	YES	2-2306316-2	
PVEDGE2FGA1V_1	58.7	NORTH/SOUTH	NO	YES	2-2306316-1	
PVEDGE2GGA1T_1	36.0	NORTH/SOUTH	YES	NO	1-2306316-5	
PVEDGE2DGA1T_1	55.2	NORTH/SOUTH	YES	NO	1-2306316-2	
PVEDGE2FGA1T_1	58.7	NORTH/SOUTH	YES	NO	1-2306316-1	
PVEDGE2GGA1T_1	36.0	NORTH/SOUTH	NO	NO	2306316-5	
PVEDGE2DGA1T_1	55.2	NORTH/SOUTH	NO	NO	2306316-2	
PVEDGE2FGA1T_1	58.7	NORTH/SOUTH	NO	NO	2306316-1	
Model Code	7	DIM X	PV PANEL FOIL DIRECTION	MOUNTING TAPE	THERMAL INTERFACE MATERIAL	PART NO.

THIS DRAWING IS A CONTROLLED DOCUMENT.

DIMENSIONS: mm

TOLERANCES UNLESS OTHERWISE SPECIFIED:

0 PLC	±0.50
1 PLC	±0.25
2 PLC	±0.13
3 PLC	±
4 PLC	±
ANGLES	±
FINISH	±

MATERIAL: 1

APPROVALS:

DWN	RAVLS	13AUG2016
CHK	GINGRICH CHUCK	13AUG2016
APVD	GINGRICH CHUCK	13AUG2016

PRODUCT SPEC: 108-32122

APPLICATION SPEC: 114-32157

WEIGHT: -

CUSTOMER DRAWING

SCALE: 1:1

SHEET 1 OF 3

REV B

STE TE Connectivity

NAME: PV EDGE ASSEMBLY, WITH FLAP, OMEGA-CLIP

SIZE: A2

DRAWING NO: C-2306316

RESTRICTED TO: -

THIS DRAWING IS UNPUBLISHED. RELEASED FOR PUBLICATION  
 © COPYRIGHT copyright.d8te ALL RIGHTS RESERVED.

REVISIONS				
P	LTR	DESCRIPTION	DATE	APVD
-		SEE SHEET 1	-	-

LID NOT SHOWN FOR REFERENCE ONLY

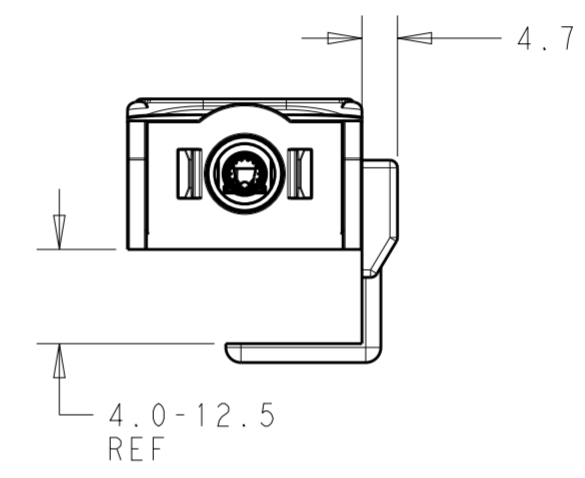
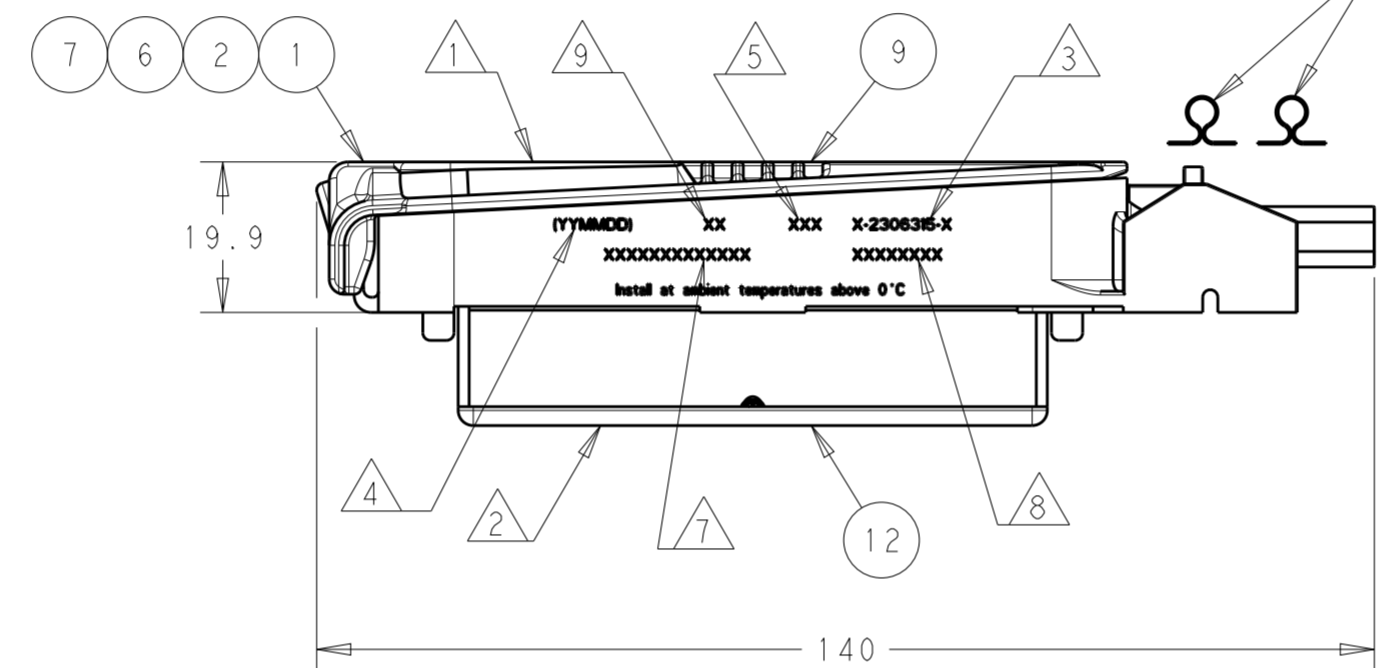
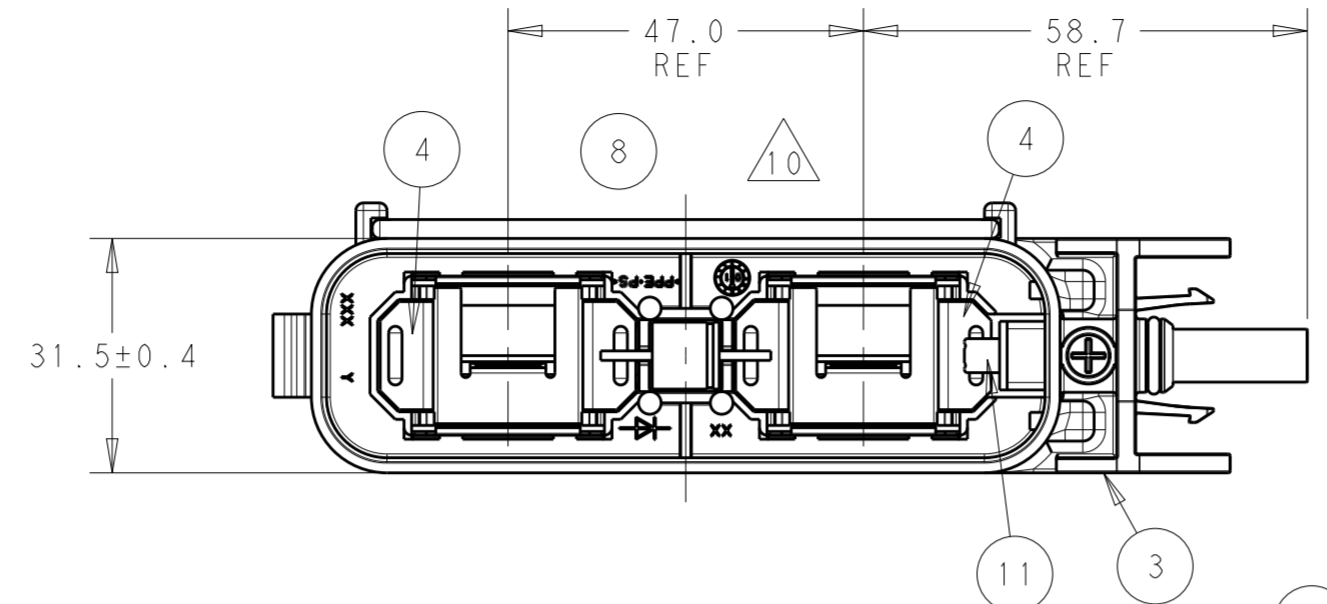

- 2306316-1
- 1-2306316-1
- 2-2306316-1
- 3-2306316-1
- SHOWN

LID NOT SHOWN FOR REFERENCE ONLY

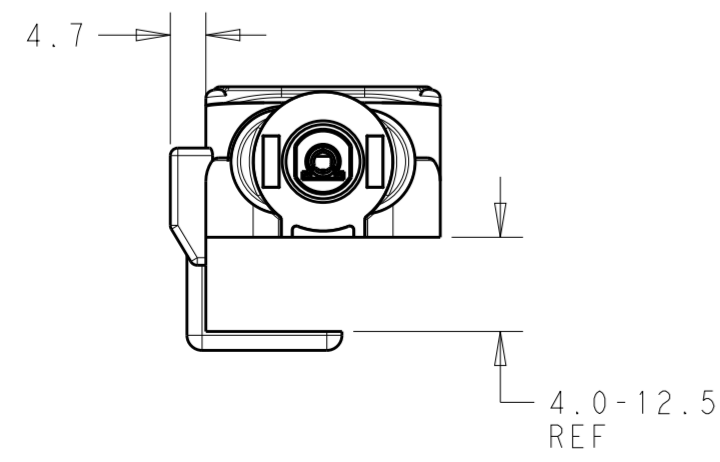
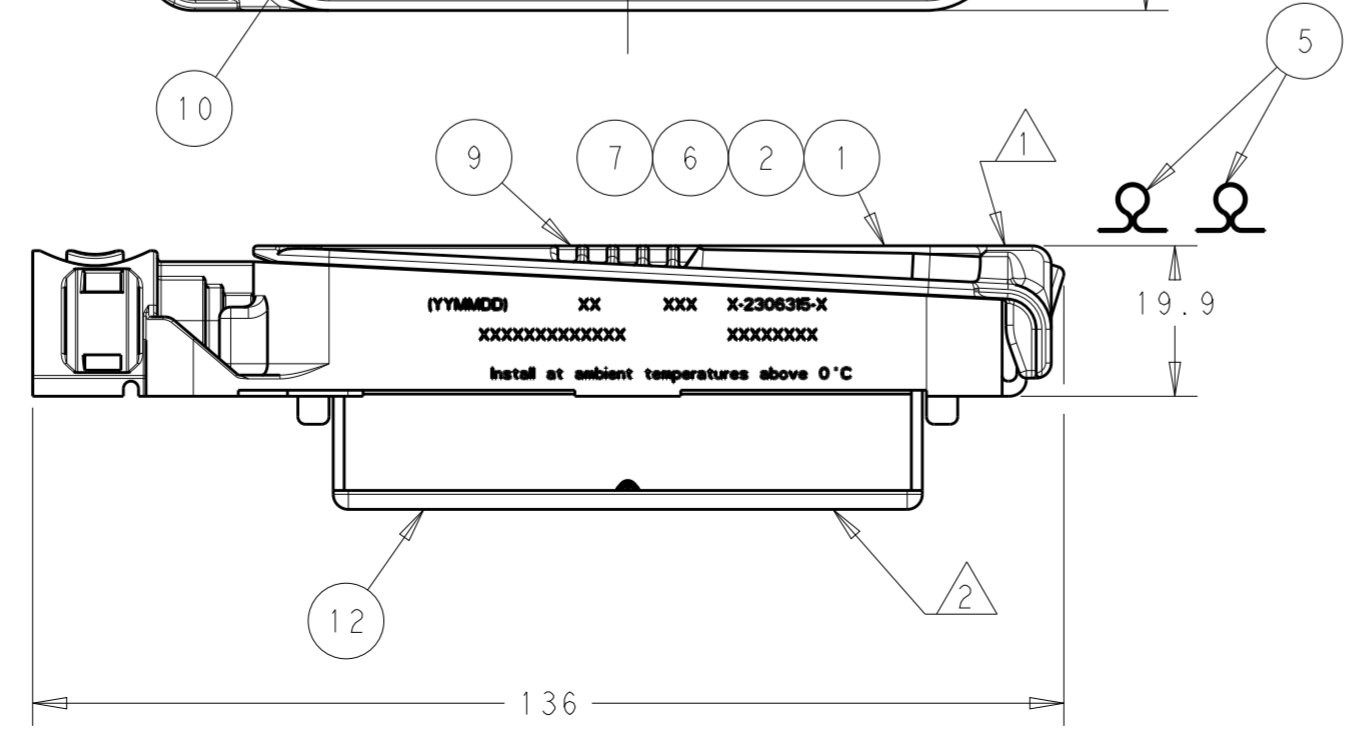
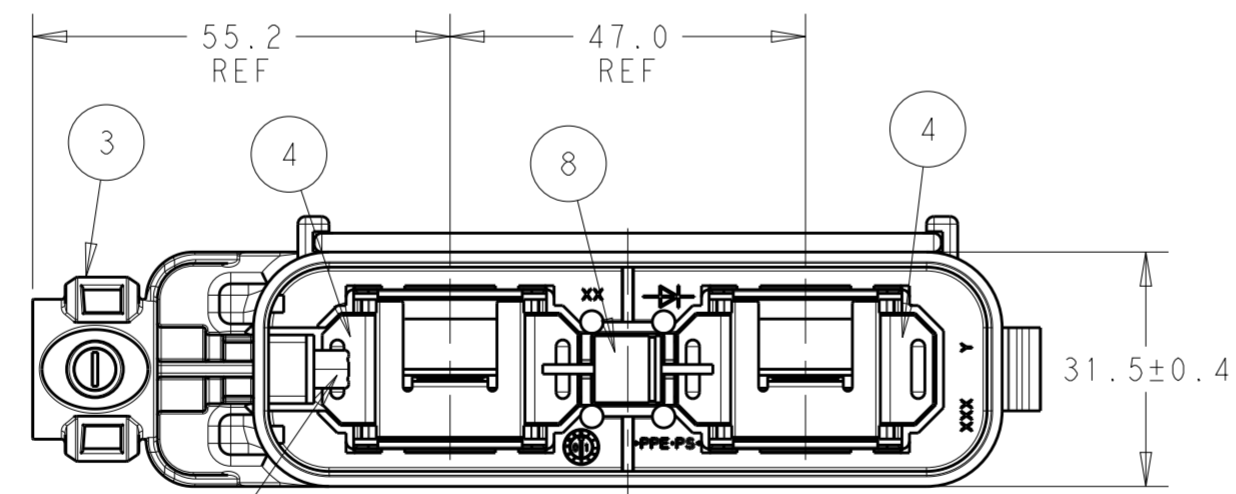

- 2306316-2
- 1-2306316-2
- 2-2306316-2
- 3-2306316-2
- SHOWN

THIS DRAWING IS A CONTROLLED DOCUMENT.		DWN RAVLS 13AUG2016	TE Connectivity	
DIMENSIONS: mm		CHK GINGRICH CHUCK 13AUG2016		
TOLERANCES UNLESS OTHERWISE SPECIFIED:		APVD GINGRICH CHUCK 13AUG2016	PRODUCT SPEC 108-32122	RESTRICTED TO
0 PLC ±0.50 1 PLC ±0.25 2 PLC ±0.13 3 PLC ± 4 PLC ± ANGLES ± FINISH ±		APPLICATION SPEC 114-32157	WEIGHT -	SIZE A2
MATERIAL		CUSTOMER DRAWING	SCALE 5:1	SHEET 2 OF 3
				REV B

THIS DRAWING IS UNPUBLISHED. RELEASED FOR PUBLICATION  
 © COPYRIGHT copyright.d8te- ALL RIGHTS RESERVED.

REVISIONS				
P	LTR	DESCRIPTION	DATE	APVD
-	-	SEE SHEET 1	-	-

LID NOT SHOWN FOR REFERENCE ONLY

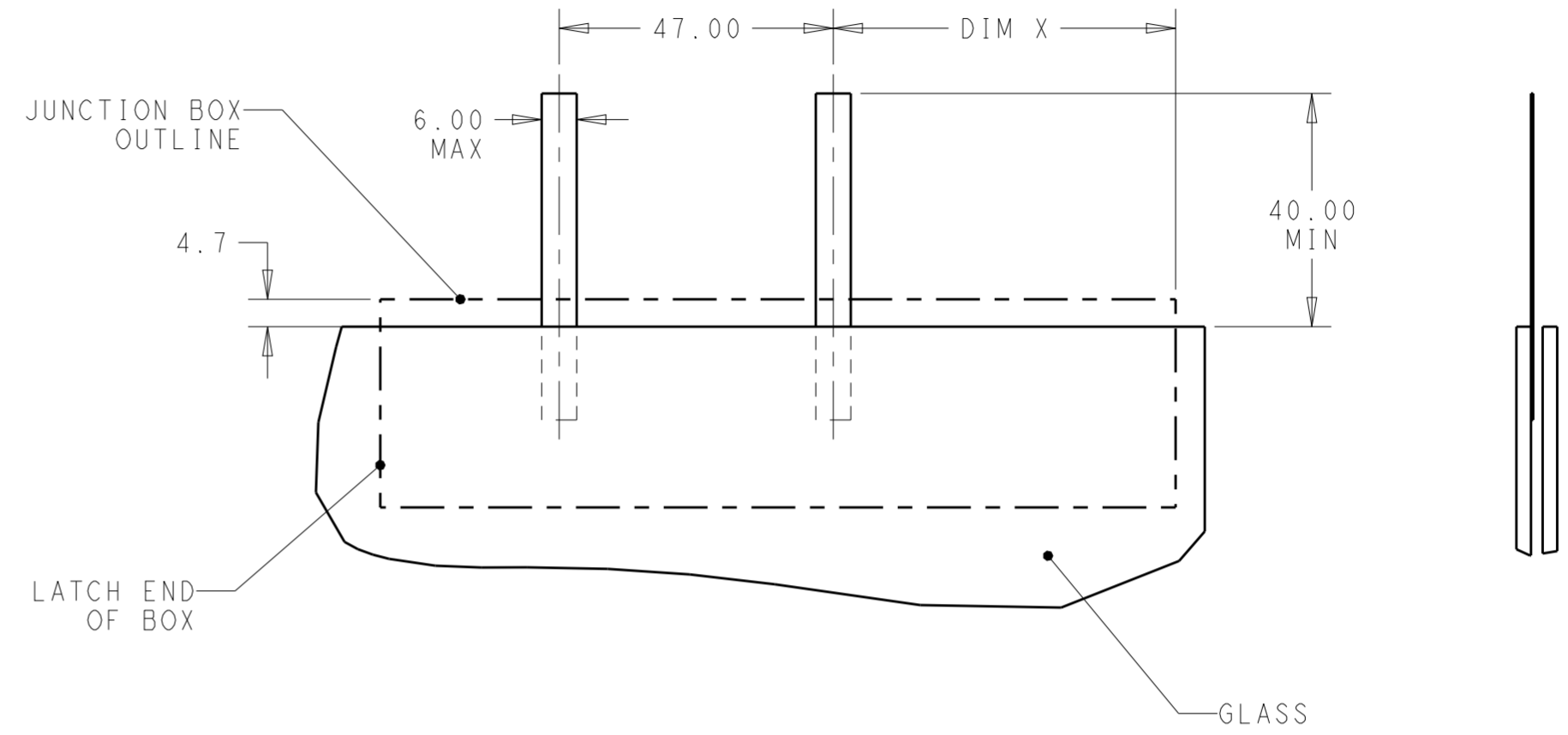
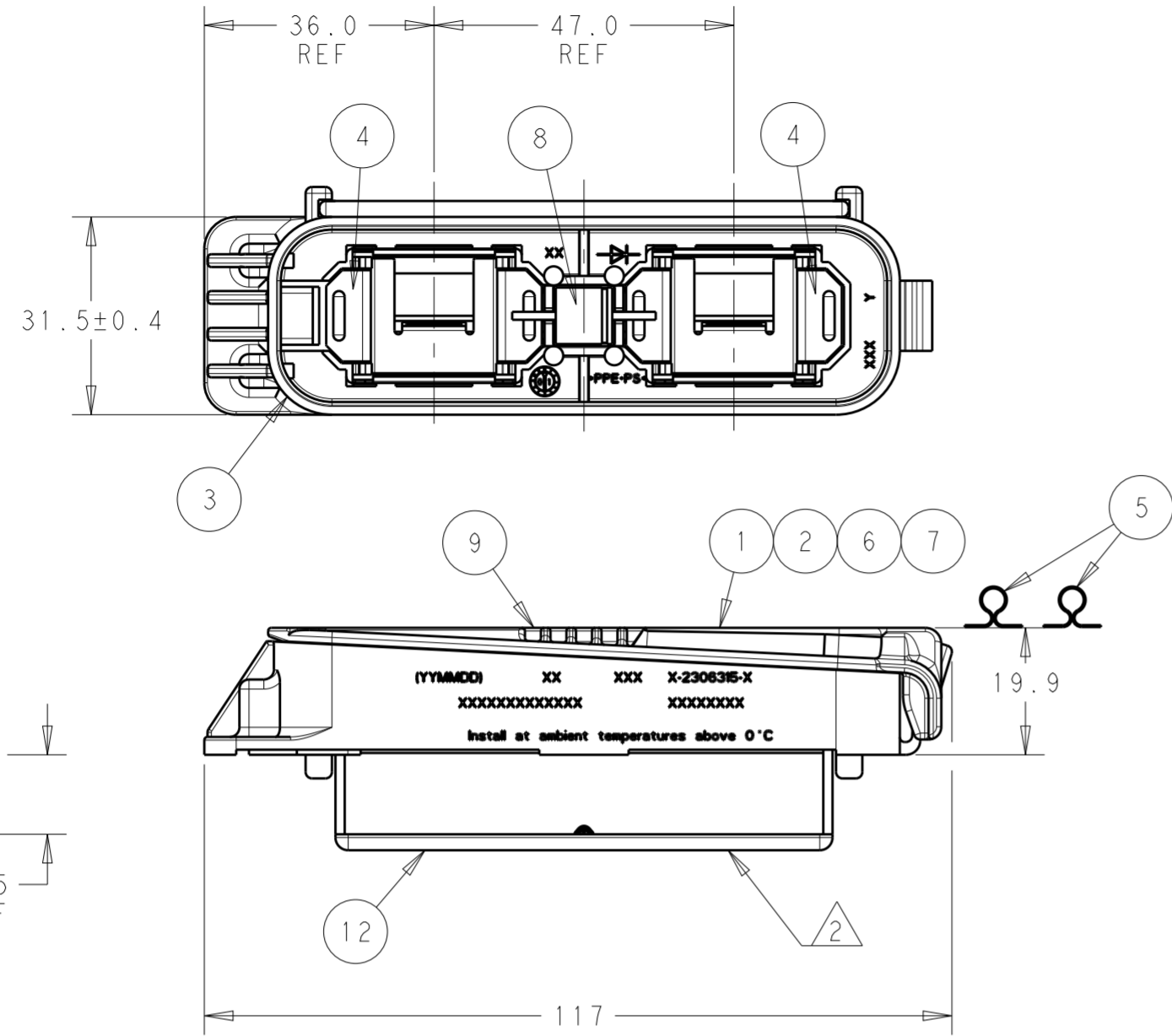

- 2306316-5
- 1-2306316-5
- 2-2306316-5
- 3-2306316-5
- SHOWN

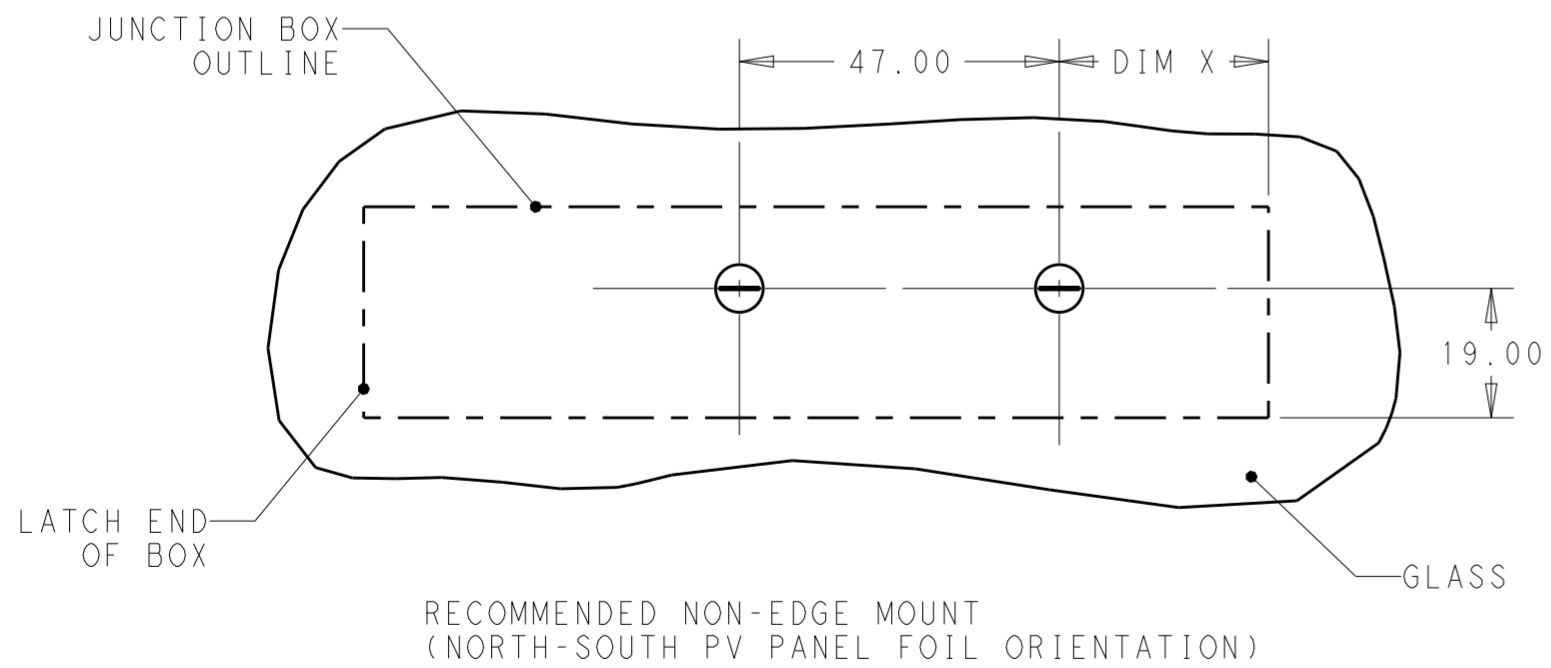

SEE 114-32157 FOR FOIL THICKNESS RANGE

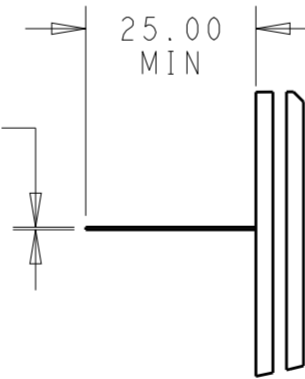

SEE 114-32157 FOR FOIL THICKNESS RANGE

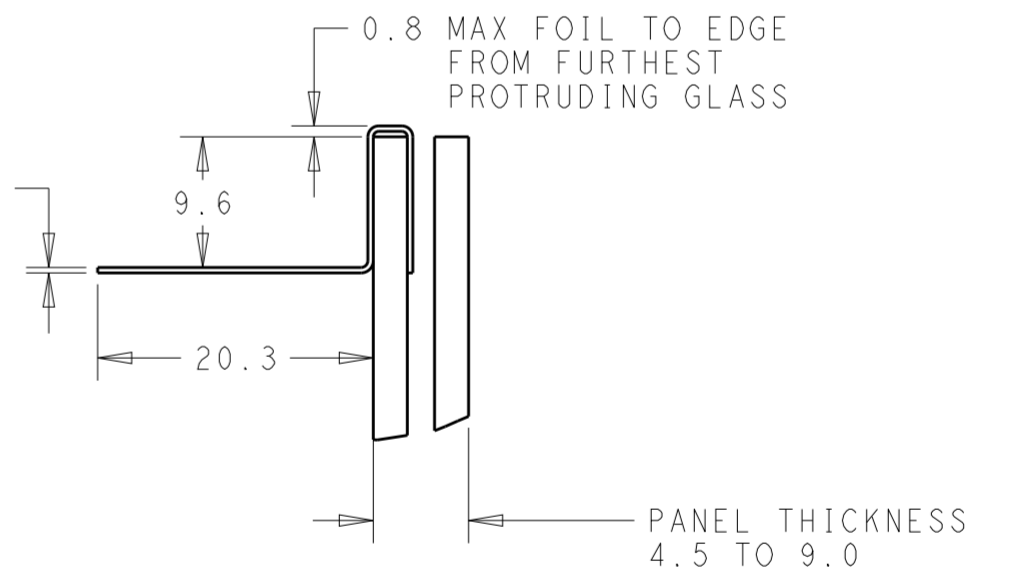

AS FORMED READY FOR ASSEMBLY OF JUNCTION BOX

THIS DRAWING IS A CONTROLLED DOCUMENT.		DWN RAVLS 13AUG2016	<b>STE</b> TE Connectivity	
DIMENSIONS: mm		CHK GINGRICH CHUCK 13AUG2016		
TOLERANCES UNLESS OTHERWISE SPECIFIED:		APVD GINGRICH CHUCK 13AUG2016	NAME PV EDGE ASSEMBLY, WITH FLAP, OMEGA-CLIP	
0 PLC ±0.50		PRODUCT SPEC 108-32122	RESTRICTED TO	
1 PLC ±0.25		APPLICATION SPEC 114-32157	SIZE A2	CAGE CODE C-2306316
2 PLC ±0.13		WEIGHT -	SCALE 5:1	SHEET 3 OF 3
3 PLC ±		CUSTOMER DRAWING	REV B	
4 PLC ±				
ANGLES ±				
FINISH ±				