



MQS/JPT
Sealed MQS/JPT 81/40pos Connector

411-78008-1
03AUG2018 Rev. A1

	Y _T E.A
	Y _T E.B
	M _T A
	Y _T E.A
	M _T A
	M _T A
	J _T

F

	M _T A	DIN .FL parts and
	M _T A	DIN .FL parts and
	J _T	DIN .FL parts and
	J _T	DIN .FL parts and
	J _T	DIN .FL parts and

F

J _T	

F

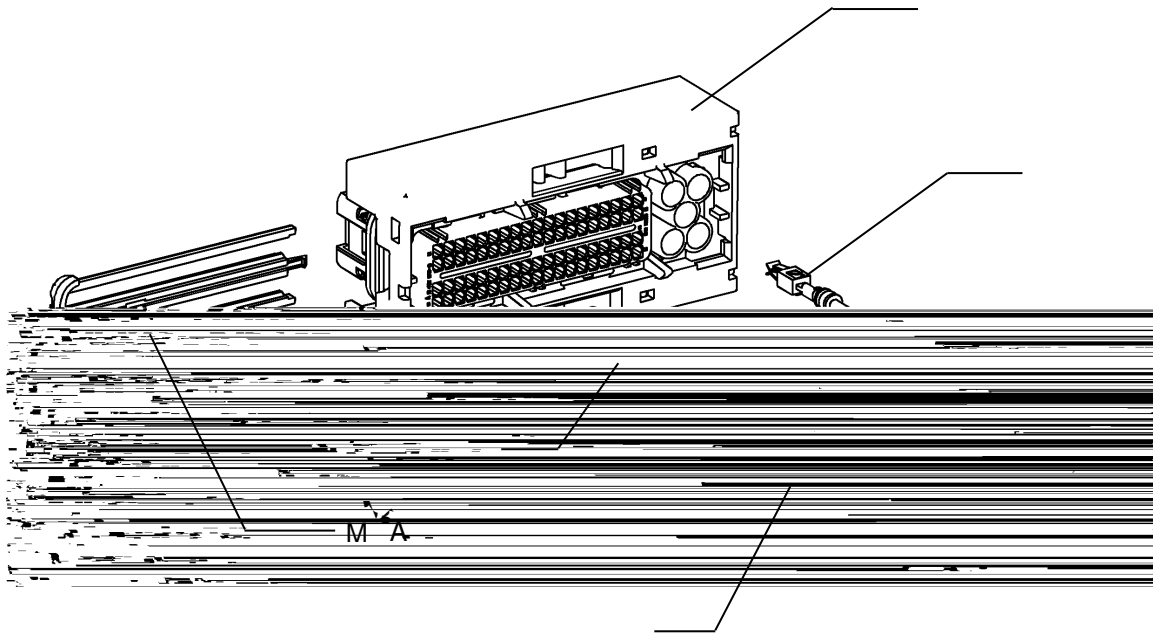



AM₁

F GA FF JwGF d F



E

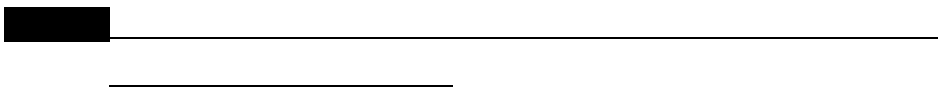
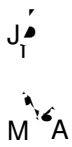
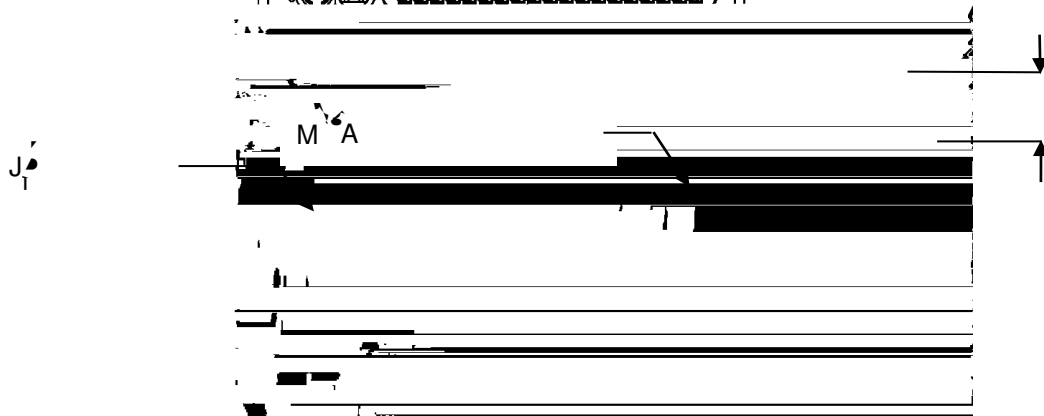
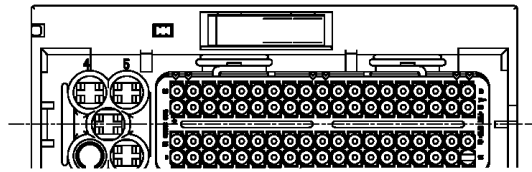
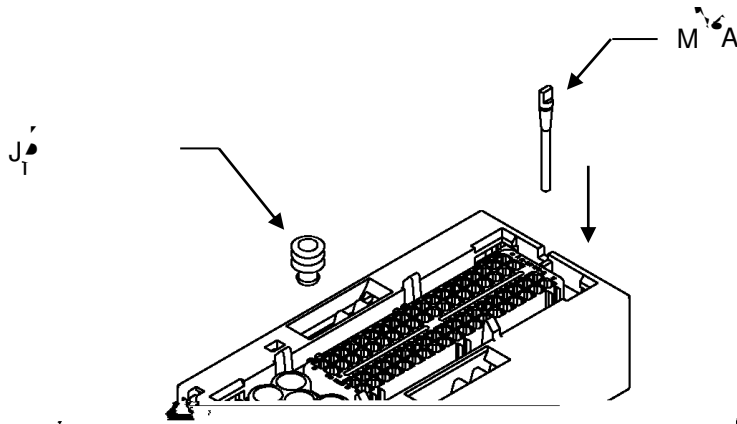

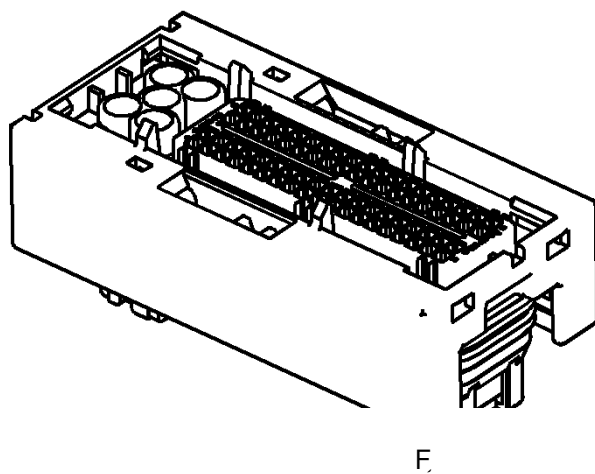
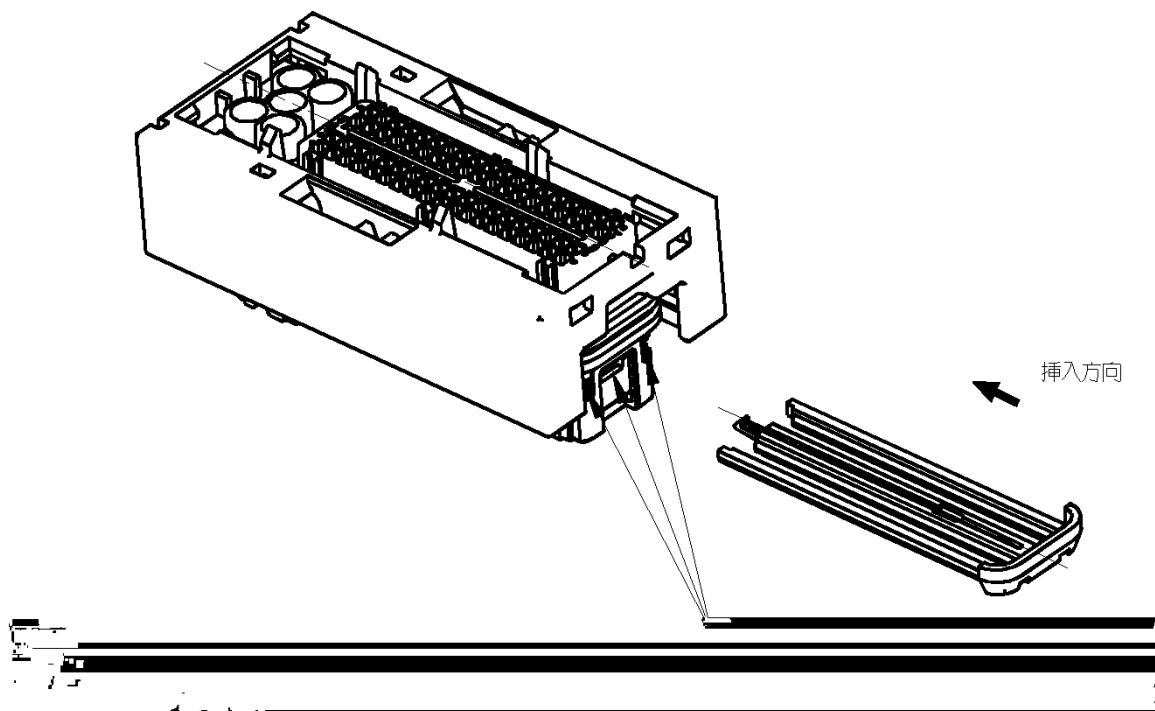

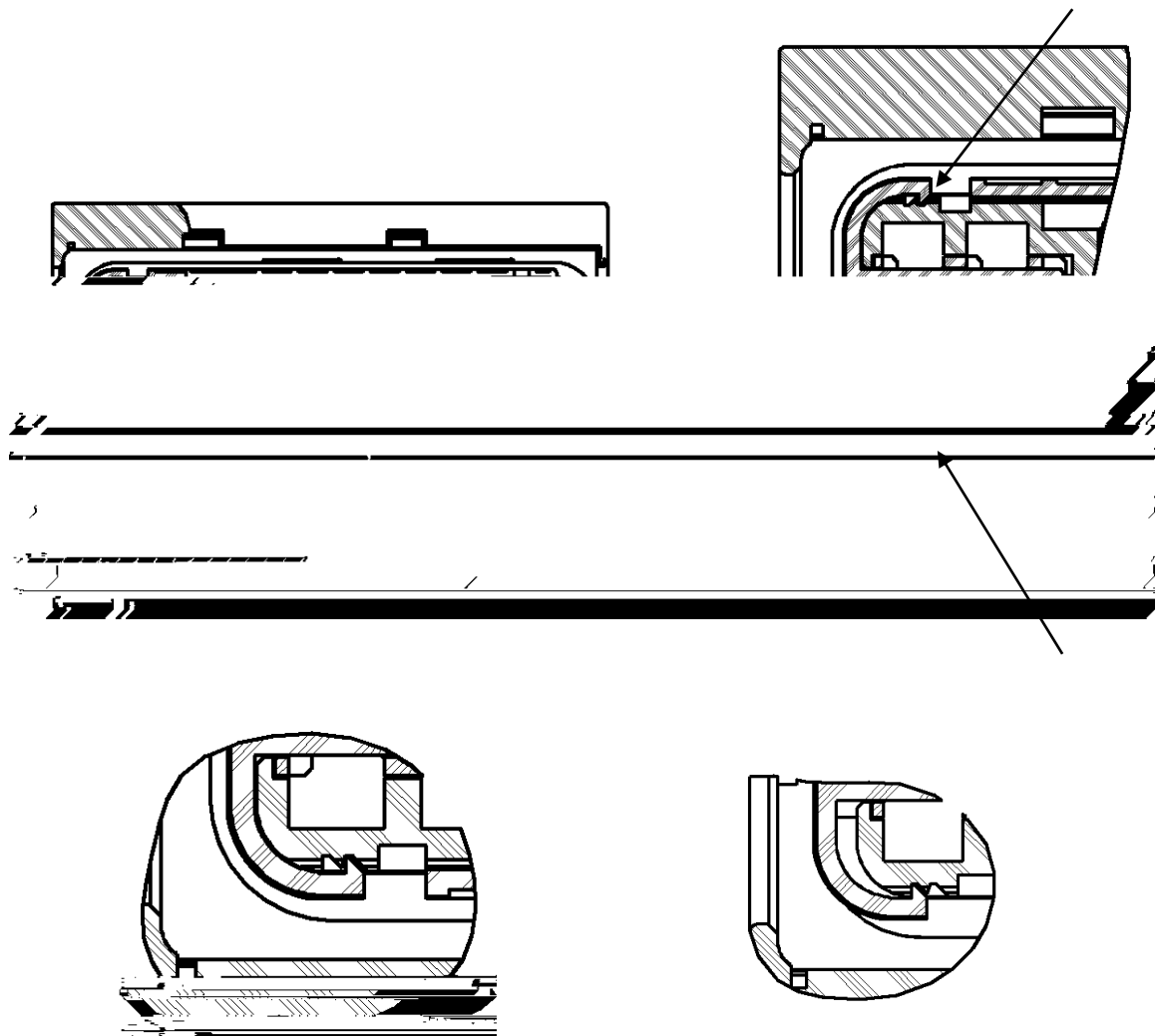

F



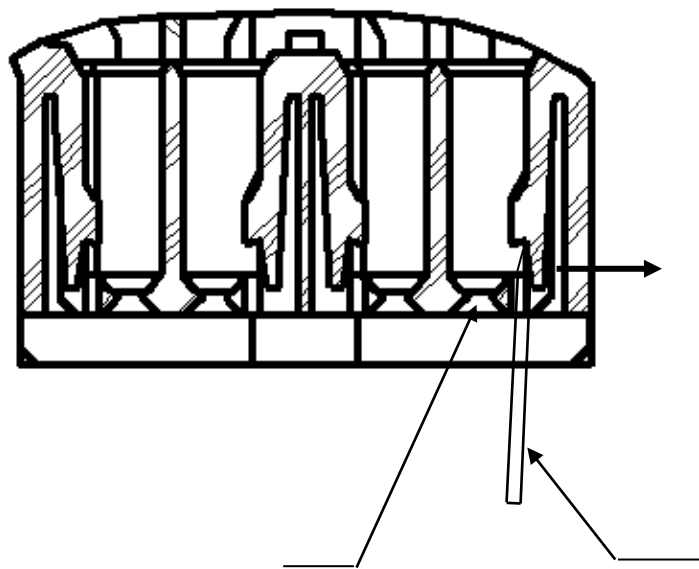
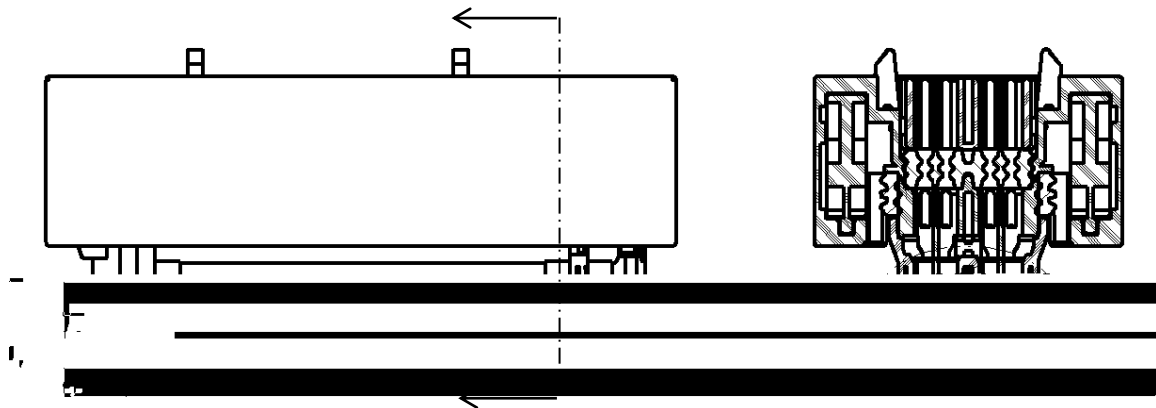

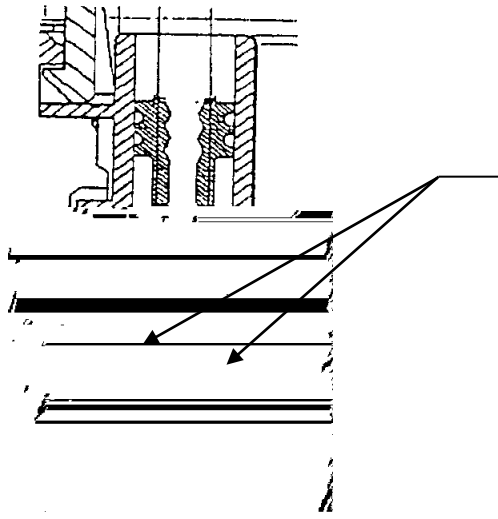
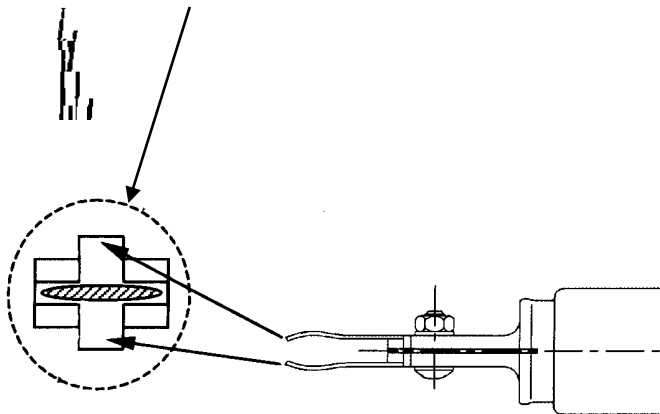
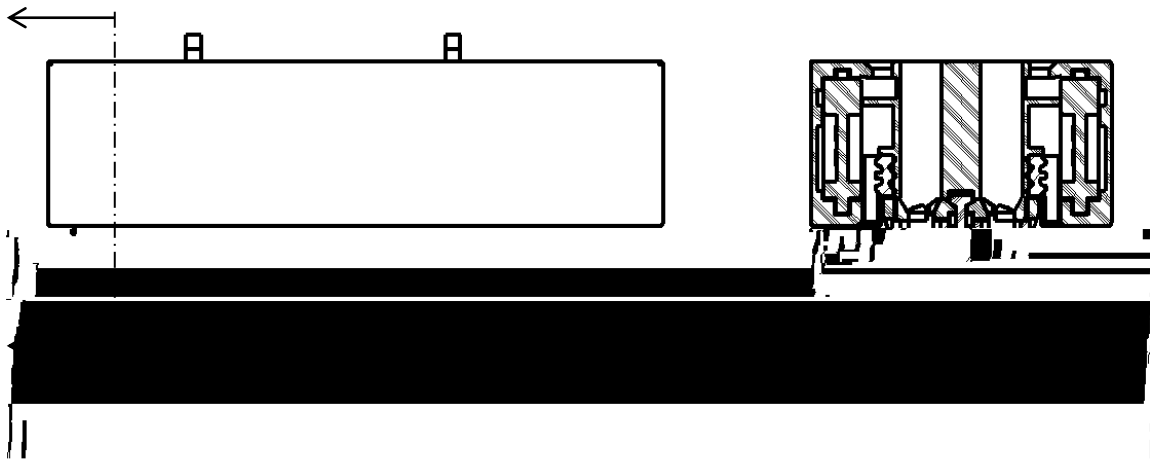
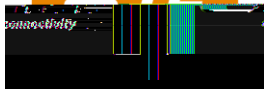



F.

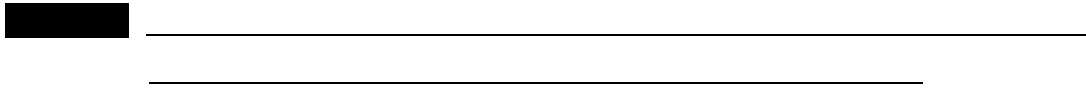

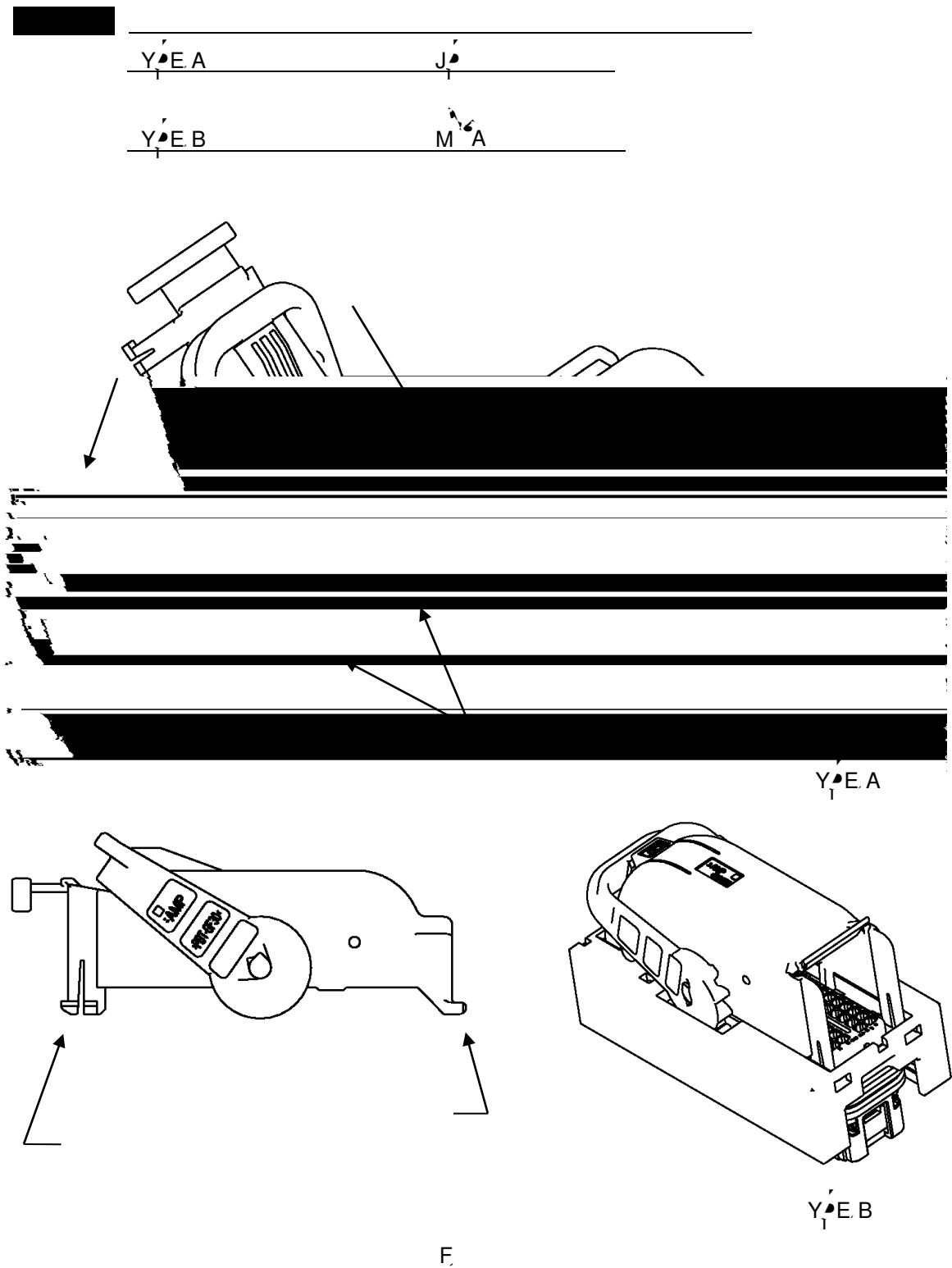



Sealed 81/40pos Connector

411-78008-1

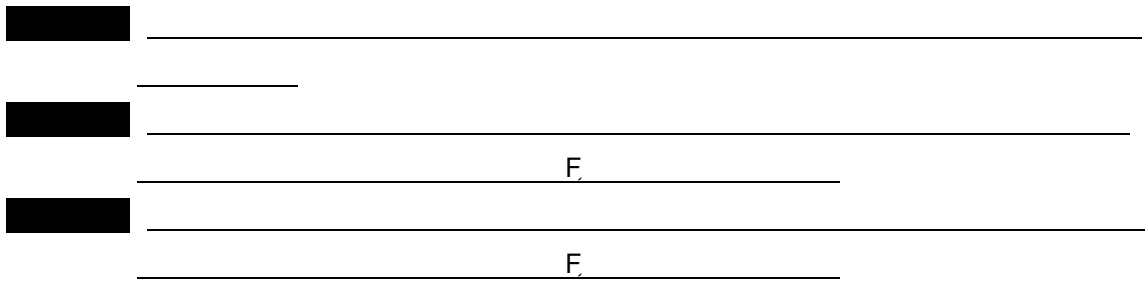

Y
I
E.A
I

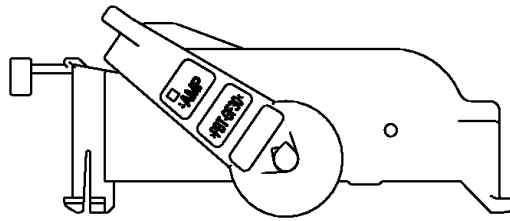

Y
I
E.B
I

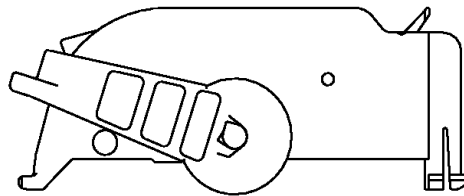

Y
I

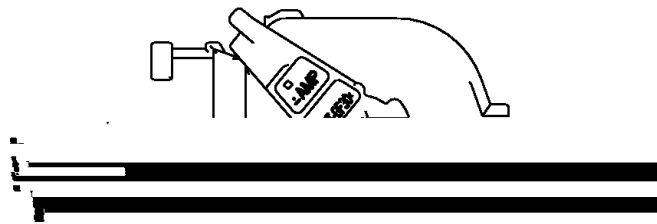

F

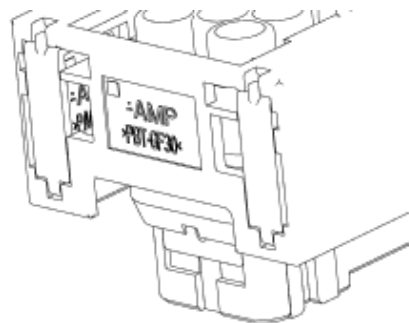

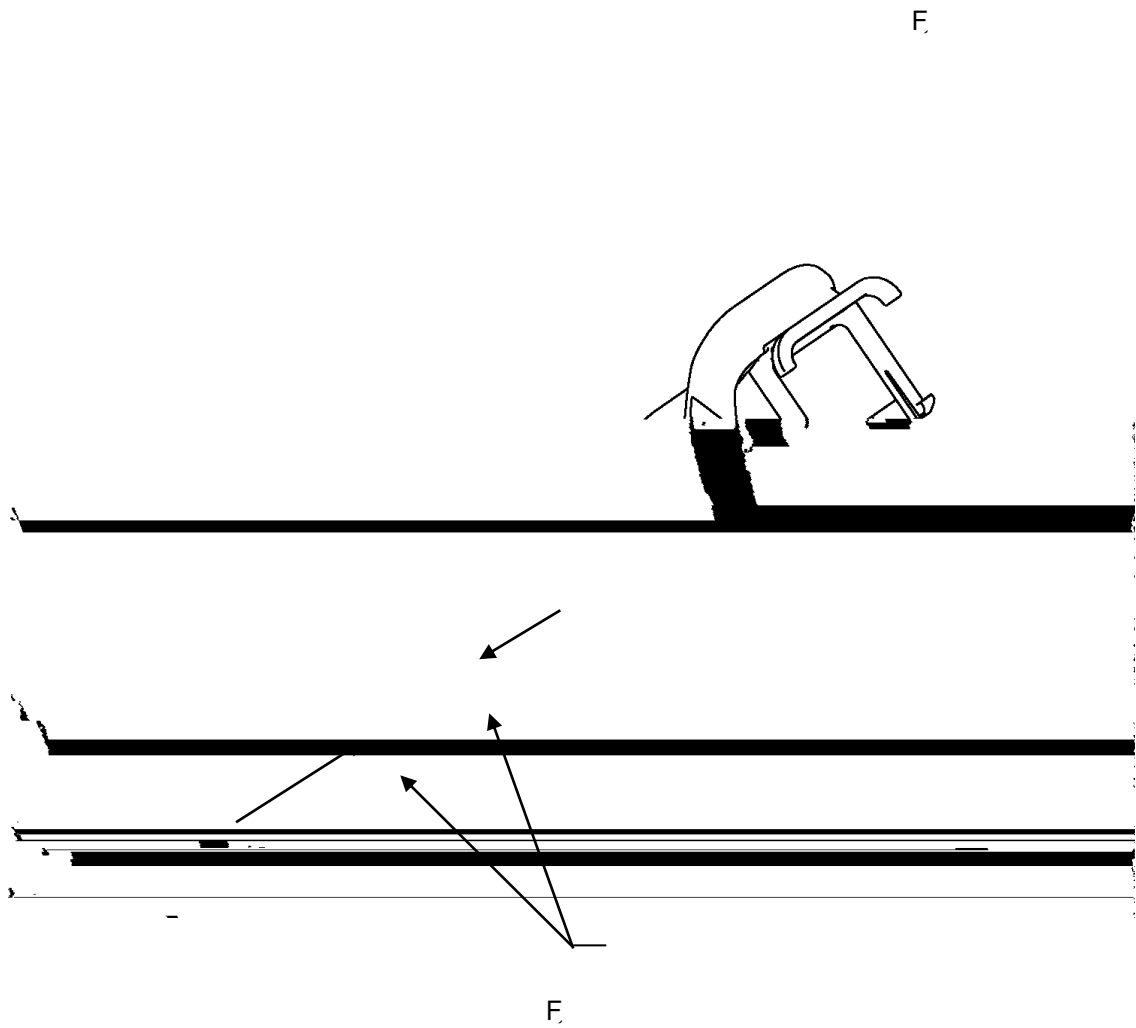

6.

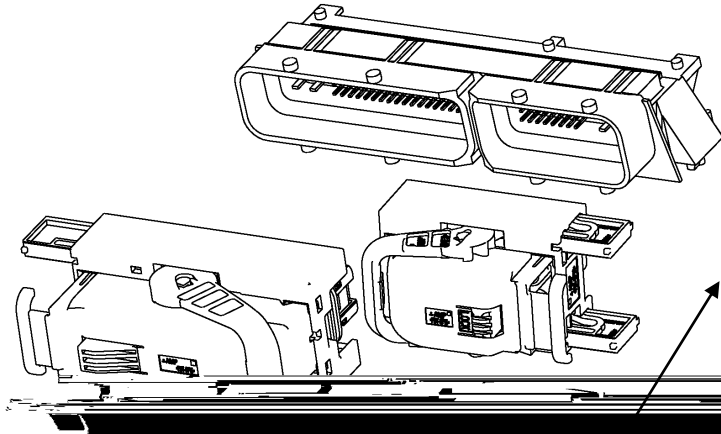

F.



F.

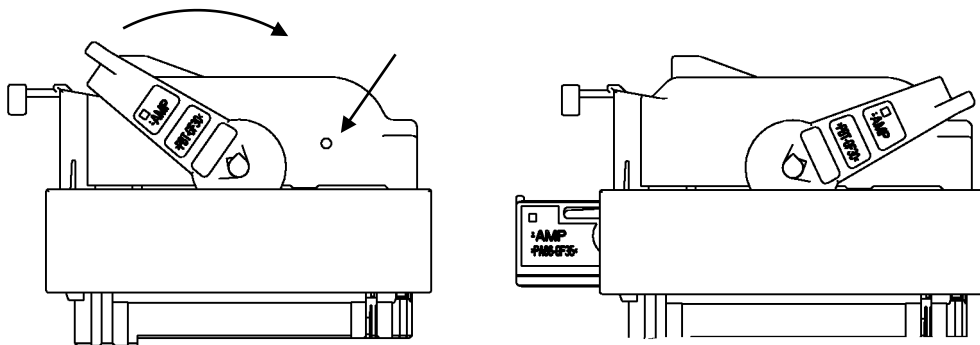

F.



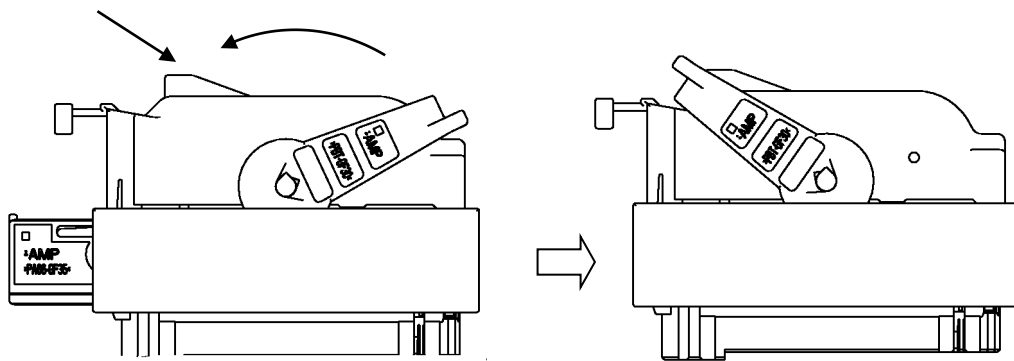

F
