

Plug Housing
Meets GWT and UL 94 V-0

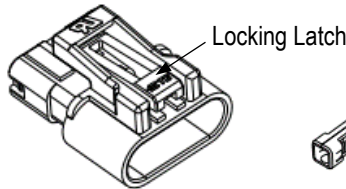

Socket Terminal

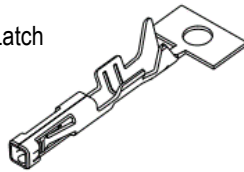

Perimeter Seal



Rear Seal



Optional TPA For Plug Housing

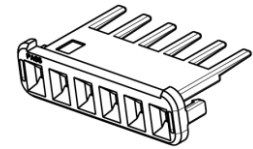

Cap Housing Free Hanging
Meets GWT and UL 94 V-0

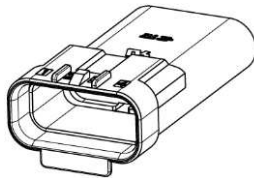

Cap Housing Panel Mount
Meets GWT and UL 94 V-0

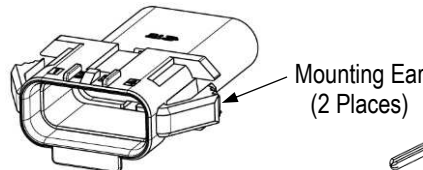

Tab Terminal

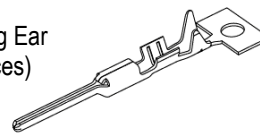

Optional TPA For Cap Housing

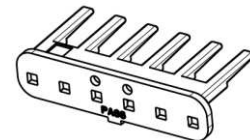

GWT is the glow wire test required by IEC/EN 60335-1

REFERENCE PRODUCT PART NUMBERS

Plug Housing	Optional TPA for Pug Housing	Perimeter Seal	Socket Terminal	Rear Seal	Cap Housing Free Hanging	Cap Housing Panel Mount	Optional TPA for Cap Housing	Tab Terminal
2321918-X	2321919-X	2321920-X	X-2321921-X	2321922-X	2321924-X	2321926-X	2321927-X	X-2321928-X

Figure 1

This instruction sheet provides assembly and disassembly procedures for the SDL2.5 water proof connector listed in Figure 1. Read instructions thoroughly before assembly. Reference product part numbers are given in Figure 1.

A basic connector assembly consists of a plug housing and a cap housing having an identical number of circuit positions. The housing can be used for panel mounting or free hanging applications and are fully polarized for proper engagement. The positive lock feature prevents accidental disengagement.

Housings are available with 2 through 6 circuit positions. Each contact cavity is numbered on the BACK of plug housing and FRONT of cap housing to provide circuit identification.

For detailed product description and application requirements, refer to application specification [114-143069](#).



NOTE

A complete list of current connectors and contact part numbers cannot be maintained in this document. For all part numbers and their description, refer to the applicable catalog, or call **PRODUCT INFO** at the bottom of this page.



NOTE

Dimensions in this instruction sheet are in metric units [with U.S. customary units in brackets]. Figures are not drawn to scale.

Reasons for re-issue of this instruction sheet are provided in Section 4, REVISION SUMMARY.

PRELIMINARY

1. ASSEMBLY

1.1. Inserting Rear Seal (Plug and Cap Housings)

1. Align the rear seal with housing at the BACK (wire side).

2. Push the rear seal into housing gradually until it fully sits in position. Refer to Figure 2
3. Visually inspect that rear seals have fully installed in the housing.



NOTE

Rear seal should be free of any damage after inserting. During delivery and operation, no contamination is allowed on rear seal. Meanwhile do not touch sealing surface directly, otherwise sealing performance would be affected due to the removal of oil.

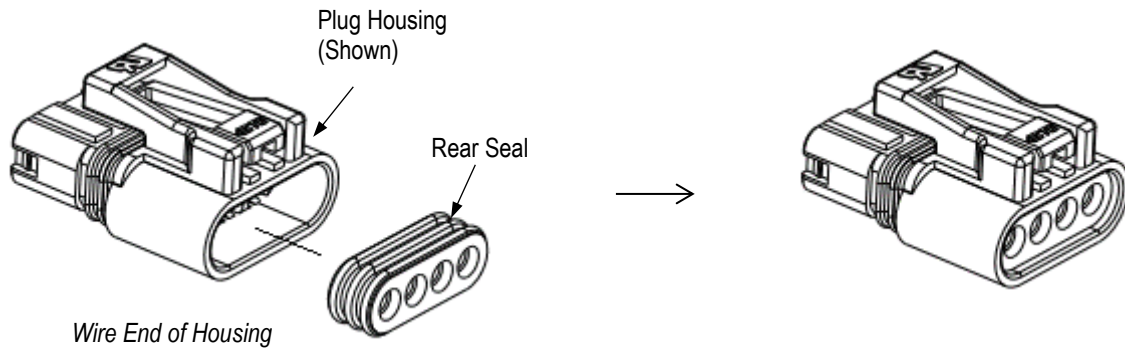

Figure 2

1.2. Inserting Perimeter Seal (Plug Housings)

1. Align the perimeter seal with housing at the FRONT (mating side).
2. Install the perimeter seal onto plug housing. Refer to Figure 3 **Error! Reference source not found.**
3. Visually inspect that perimeter seal has fully installed in the housing, any fold is not permitted.



NOTE

Perimeter seal should be free of any damage and fold after inserting. During delivery and operation, no contamination is allowed on perimeter seal. Meanwhile do not touch sealing surface directly, otherwise sealing performance would be affected due to the removal of oil.

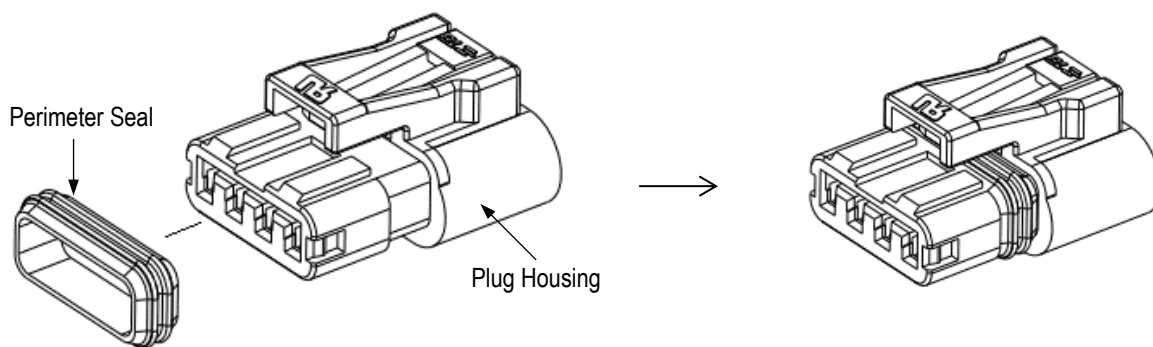

Figure 3

1.3. Inserting Contacts (Plug and Cap Housings)

1. Ensure that the contacts are crimped to meet the requirements given in [114-143069](#). Strip form contacts are designed to be crimped with a miniature applicator in a semi-automatic or automatic machine. Loose piece contacts are designed to be crimped with a hand crimp tool.
2. Make sure to align contacts with the desired circuit cavity at the BACK of the rear housing section. Grasp the wire-directly behind the contact insulation barrel-and push the contact straight into the

cavity until it bottoms (there should be an audible click). Pull back lightly on the wire to be sure the contact is locked in place. Refer to Figure 4.

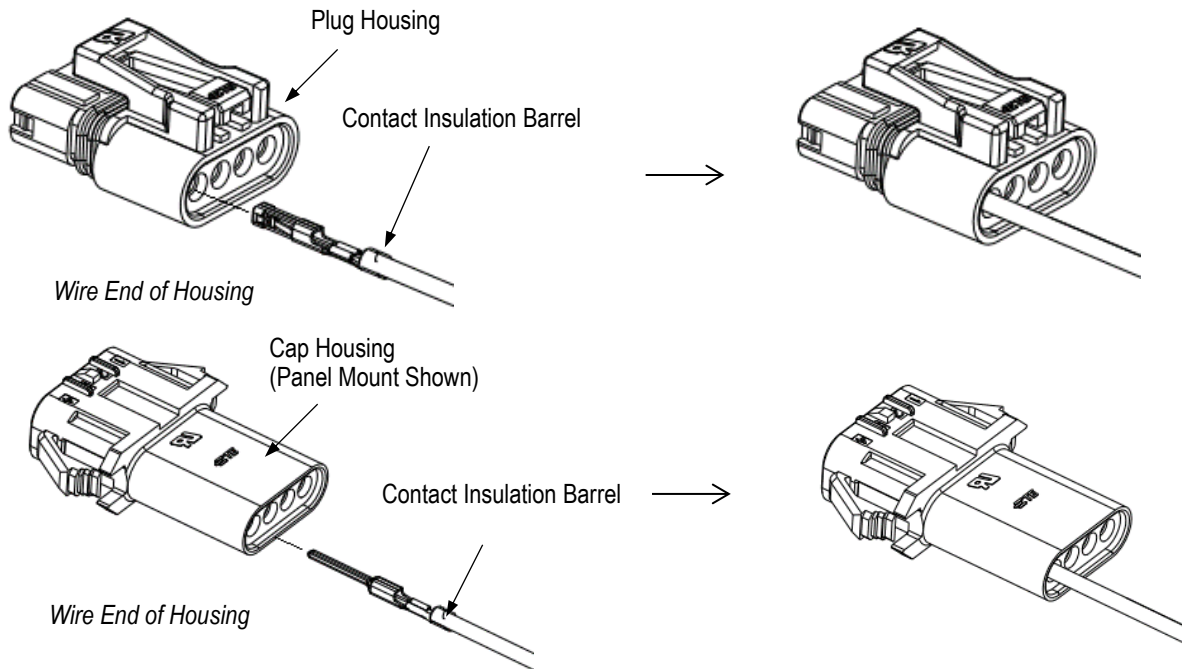

Figure 4

1.4. Inserting Optional TPA (Plug and Cap Housings)

1. Grasp the TPA and push TPA straight into the plug and cap housing from FRONT (there should be a slight audible click). Refer to Figure 5.

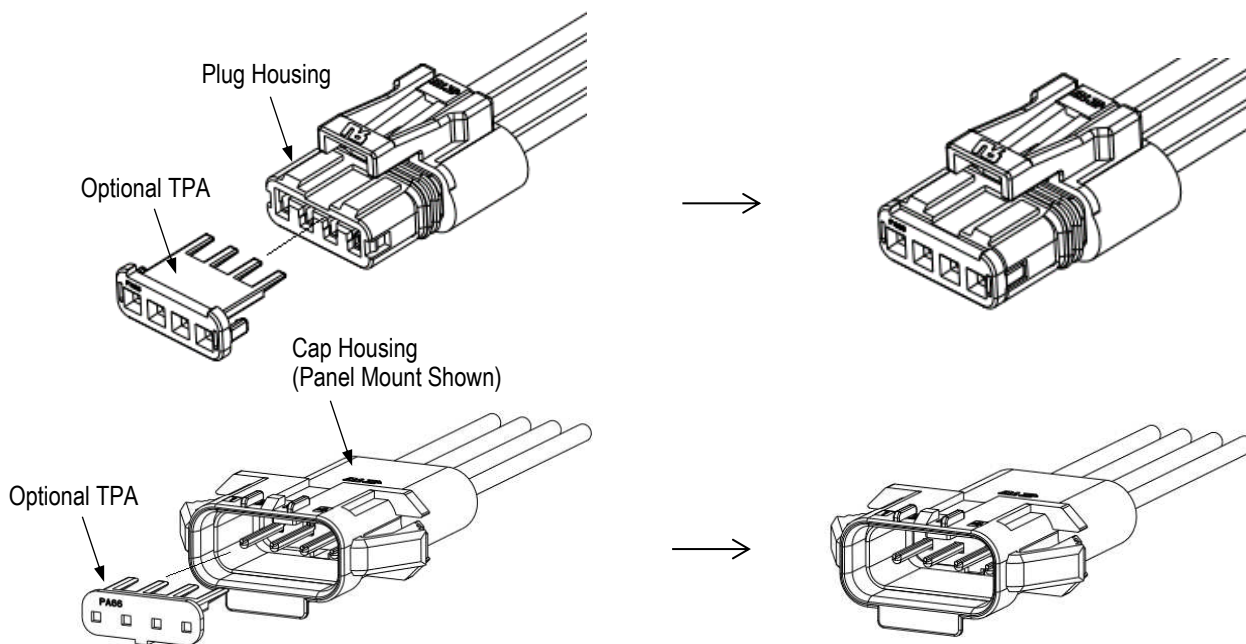

Figure 5

1.5. Panel Mounting (Cap Housings)

The cap housing features flexible mounting latches for easy insertion into the panel cutout.

1. Cut a panel having the thickness and dimensions given on corresponding customer drawing.
2. Push the cap housing through the panel in the same direction the panel cutout was made, until it snaps into place. Refer to Figure 6.
3. If removal is necessary, deflect the mounting ears until they clear the panel, then pull the cap housing through either the front or back of the panel.

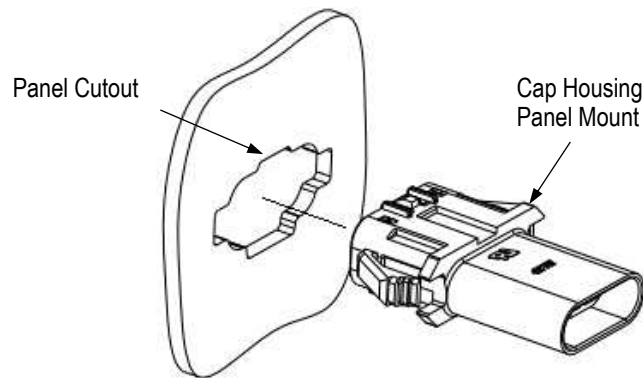

Figure 6

1.6. Mating Connectors

Ensure that the mating connectors have identical number of circuits and a pin contact mating with a socket contact. Align the mating faces of the connectors and push them together until the locking latch fully engages the locking tab. Pull back to ensure proper engagement and to prevent any deformation of the locking mechanism. Refer to Figure 7.

Note: Panel Mount Shown

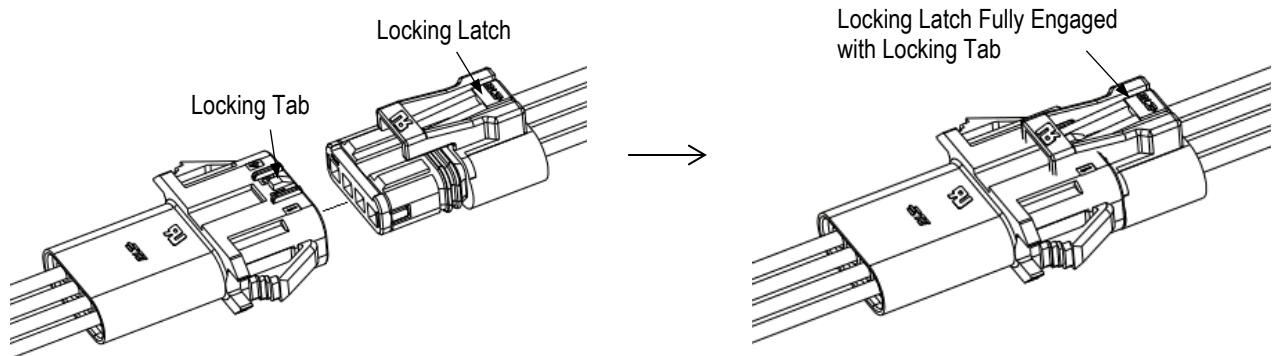

Figure 7

1.7. Unmating Connectors

To disengage mating connectors, depress latch of plug housing with thumbnail, and pull the connectors apart. Refer to Figure 8.



NOTE
DO NOT pull the connectors by the wires.

Note: Panel Mount Shown

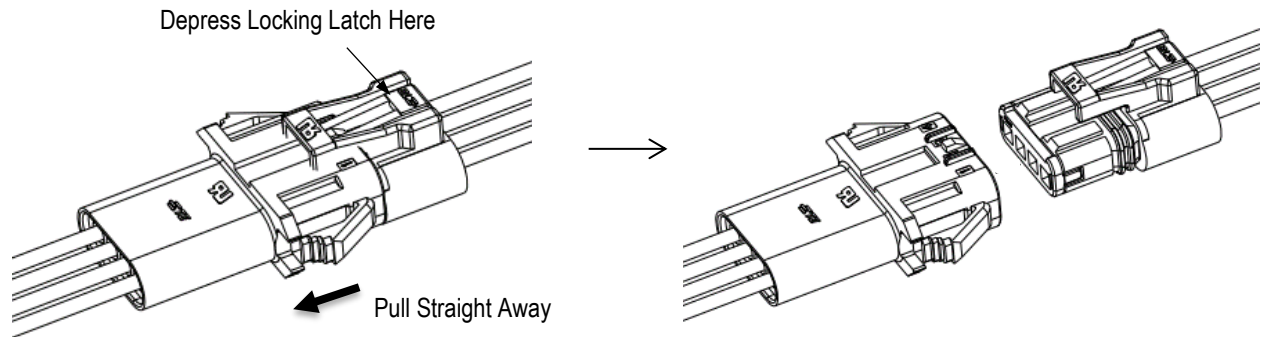

Figure 8

2. TPA EXTRACTION

TPA can be removed from the plug or cap housing using extraction tool.

3. REPLACEMENT AND REPAIR

Do not use defective or damaged product. These products cannot be repaired. For replacement information, call the number at the bottom of page 1.

4. REVISION SUMMARY

Revisions to this instruction sheet include

- Initial release