

Mounting specification

Specifications for surface mount type

- Reflow guaranteed condition
- < RoHS compliant >

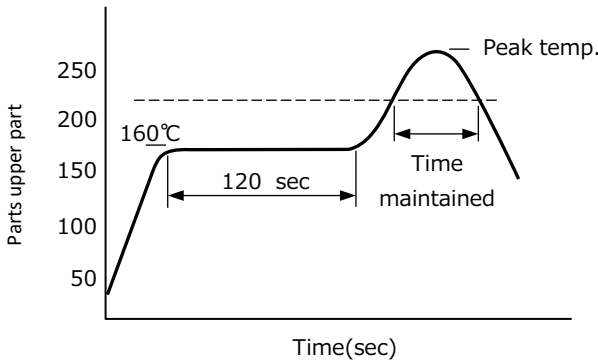

Size code	C, D, D8	F, G, G16	
Peak temp.	260°C (255°C)	245°C	260°C
Time in peak temperature	≥ 250°C 5 s (10 s)	≥ 240°C 10 s	≥ 250°C 5 s
Time maintained	≥ 230°C 30 s	≥ 230°C 30 s	≥ 230°C 30 s
	≥ 217°C 40 s	≥ 217°C 40 s	≥ 217°C 40 s
	≥ 200°C 70 s	≥ 200°C 70 s	≥ 200°C 70 s
Time of reflow	2 times	2 times	1 time

* For reflow, use a thermal condition system such as infrared and radiation (IR) or hot blas
 * Panasonic have several series available for pure Tin terminal ZVEI reflow based on J-STD-020D (JEDEC).
 (Please contact sales for details.)

Specifications for radial lead type

- Flow soldering condition
- < RoHS compliant >

	Temperature	Time	Flow number
Soldering condition	260°C + 5°C or less	10 sec +1 sec or less	1 time

Vibration-proof products

The size and shape are different from standard products.
 Please inquire details of our company.

< Size code : D, D8 >

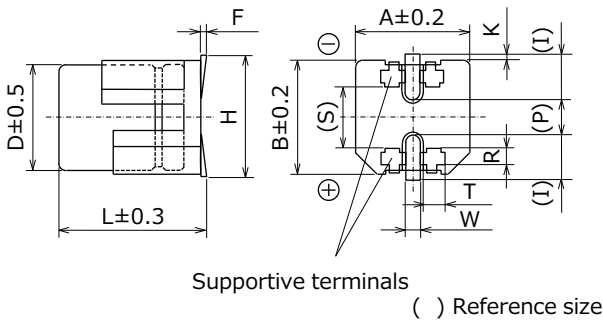

Unit : mm

Size code	φD	L	A, B	H max.	F	I	W
D	6.3	6.1	6.6	7.8	0 to +0.15	2.4	0.65±0.1
D8	6.3	8.0	6.6	7.8	0 to +0.15	2.4	0.65±0.1

Size code	P	K	R	S	T
D	2.2	0.35 ^{+0.15/-0.20}	1.1±0.2	3.3	1.05±0.2
D8	2.2	0.35 ^{+0.15/-0.20}	1.1±0.2	3.3	1.05±0.2

Supportive terminals
 () Reference size

< Size code : F, G, G16 >

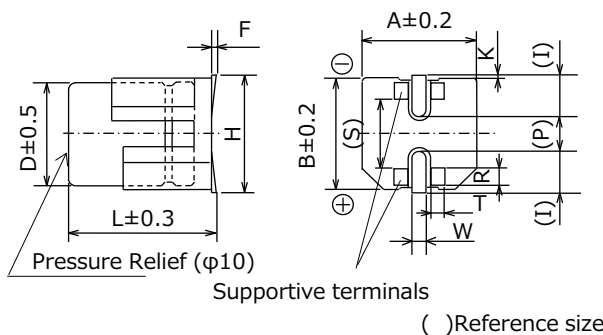

Unit : mm

Size code	φD	L	A, B	H max.	F	I	W
F	8.0	10.5	8.3	10.0	0 to +0.15	3.4	1.2±0.2
G	10.0	10.5	10.3	12.0	0 to +0.15	3.5	1.2±0.2
G16	10.0	16.8	10.3	11.0 ^{*1}	0 to +0.15	3.2	1.2±0.2

*1:±0.2

Size code	P	K	R	S	T
F	3.1	0.70±0.2	0.70±0.2	5.3	1.3±0.2
G	4.6	0.70±0.2	0.70±0.2	6.9	1.3±0.2
G16	4.6	---	0.70±0.2	6.9	1.3±0.2

Supportive terminals
 ()Reference size

Mounting specification

Land / Pad pattern

The circuit board land/pad pattern size for chip capacitors is specified in the following table. The land pitch influences installation strength and consider it.

< Standard products >

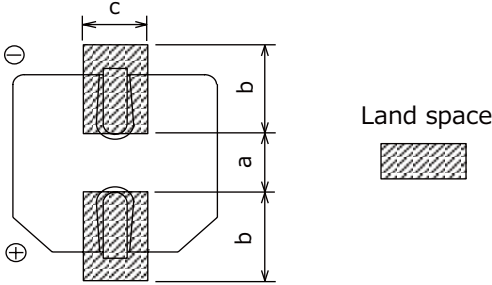

Unit : mm

Size code	a	b	c
C : $\phi 5 \times L5.8$	1.5	2.8	1.6
D : $\phi 6.3 \times L5.8$	1.8	3.2	1.6
D8 : $\phi 6.3 \times L7.7$	1.8	3.2	1.6
F : $\phi 8 \times L10.2$	3.1	4.0	2.0
G : $\phi 10 \times L10.2$	4.6	4.1	2.0
G16 : $\phi 10 \times L16.5$	4.6	4.1	2.0

When size "a" is wide, back fillet can be made, decreasing fitting strength.

*Take mounting conditions, solderability and fitting strength into consideration when selecting parts for your company's design.

< Vibration-proof products >

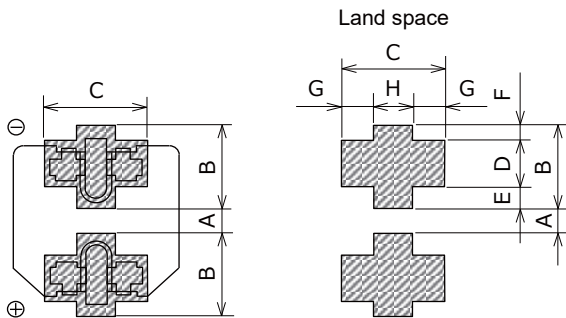

Unit : mm

Size code	A	B	C	D
D : $\phi 6.3 \times L5.8$	1.2	3.6	3.2	2.0
D8 : $\phi 6.3 \times L7.7$	1.2	3.6	3.2	2.0

Size code	E	F	G	H
D : $\phi 6.3 \times L5.8$	0.95	0.65	1.0	1.2
D8 : $\phi 6.3 \times L7.7$	0.95	0.65	1.0	1.2

When size "A" is wide, back fillet can be made, decreasing fitting strength.

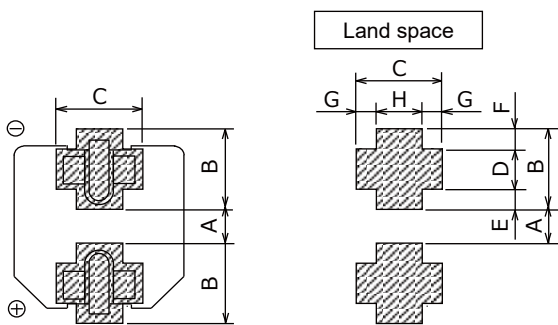

Unit : mm

Size code	A	B	C	D
F : $\phi 8 \times L10.2$	2.7	4.0	4.7	1.3
G : $\phi 10 \times L10.2$	3.9	4.4	4.7	1.3
G16 : $\phi 10 \times L16.5$	3.9	4.4	4.7	1.3

Size code	E	F	G	H
F : $\phi 8 \times L10.2$	1.0	1.7	1.1	2.5
G : $\phi 10 \times L10.2$	1.2	1.9	1.1	2.5
G16 : $\phi 10 \times L16.5$	1.2	1.9	1.1	2.5

When size "A" is wide, back fillet can be made, decreasing fitting strength.

*Take mounting conditions, solderability and fitting strength into consideration when selecting parts for your company's design.

Packaging specifications

Specifications for surface mount type

- Reel dimensions (not to scale)

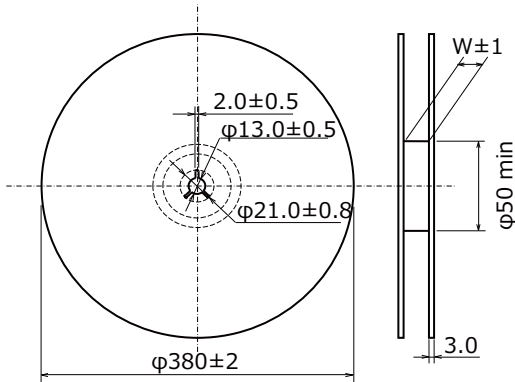

Unit : mm

Size code	W
C	14.0
D, D8	18.0
F, G, G16	26.0

- Dimensions of outer carton box

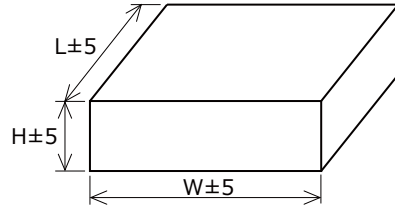

Unit : mm

Size code	H	W, L
C	220	395
D, D8	250	395
F, G, G16	220	395

- Min.packing quantity

Size code	Min.packing (pcs.)
C, D	1000
D8	900
F, G	500
G16	250

- Taping dimensions

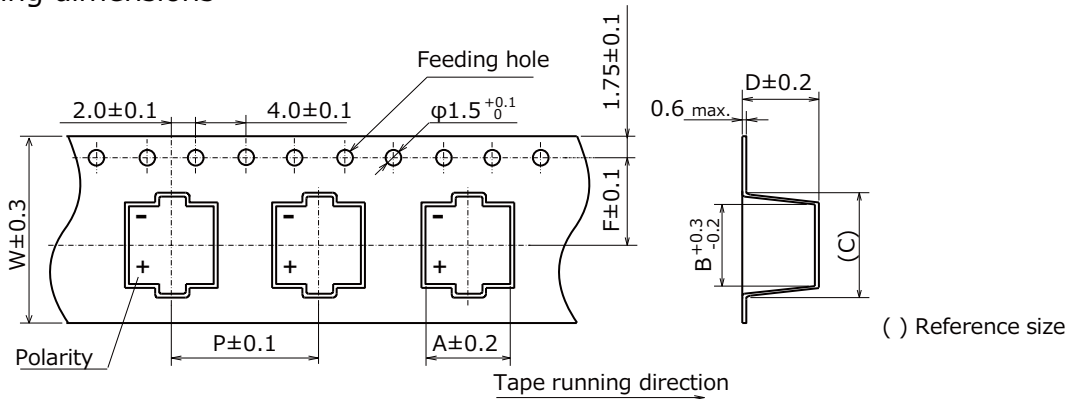

* Ask factory for technical specifications

Unit : mm

Size code	A	B	C	D	P	F	W
C	5.7	5.7	8.0	6.4	12.0	5.5	12.0
D	7.0	7.0	9.0	6.4	12.0	7.5	16.0
D8	7.0	7.0	9.0	8.4	12.0	7.5	16.0
F	8.7	8.7	12.5	11.0	16.0	11.5	24.0
G	10.7	10.7	14.5	11.0	16.0	11.5	24.0
G16	10.7	10.7	14.5	17.5	20.0	11.5	24.0

Specifications for radial lead type

- Packing quantity

Size code	Quantity (pcs. / Bag)	Quantity (pcs. / Box)
F (φ8×L9.5)	200	4000
G (φ10×L9.5)	200	2000