



**MICROCHIP**

---

**Packaging  
Specification**

---

---

**Note the following details of the code protection feature on Microchip devices:**

- Microchip products meet the specification contained in their particular Microchip Data Sheet.
- Microchip believes that its family of products is one of the most secure families of its kind on the market today, when used in the intended manner and under normal conditions.
- There are dishonest and possibly illegal methods used to breach the code protection feature. All of these methods, to our knowledge, require using the Microchip products in a manner outside the operating specifications contained in Microchip's Data Sheets. Most likely, the person doing so is engaged in theft of intellectual property.
- Microchip is willing to work with the customer who is concerned about the integrity of their code.
- Neither Microchip nor any other semiconductor manufacturer can guarantee the security of their code. Code protection does not mean that we are guaranteeing the product as "unbreakable."

Code protection is constantly evolving. We at Microchip are committed to continuously improving the code protection features of our products. Attempts to break Microchip's code protection feature may be a violation of the Digital Millennium Copyright Act. If such acts allow unauthorized access to your software or other copyrighted work, you may have a right to sue for relief under that Act.

---

Information contained in this publication regarding device applications and the like is provided only for your convenience and may be superseded by updates. It is your responsibility to ensure that your application meets with your specifications. MICROCHIP MAKES NO REPRESENTATIONS OR WARRANTIES OF ANY KIND WHETHER EXPRESS OR IMPLIED, WRITTEN OR ORAL, STATUTORY OR OTHERWISE, RELATED TO THE INFORMATION, INCLUDING BUT NOT LIMITED TO ITS CONDITION, QUALITY, PERFORMANCE, MERCHANTABILITY OR FITNESS FOR PURPOSE. Microchip disclaims all liability arising from this information and its use. Use of Microchip devices in life support and/or safety applications is entirely at the buyer's risk, and the buyer agrees to defend, indemnify and hold harmless Microchip from any and all damages, claims, suits, or expenses resulting from such use. No licenses are conveyed, implicitly or otherwise, under any Microchip intellectual property rights unless otherwise stated.

*Microchip received ISO/TS-16949:2009 certification for its worldwide headquarters, design and wafer fabrication facilities in Chandler and Tempe, Arizona; Gresham, Oregon and design centers in California and India. The Company's quality system processes and procedures are for its PIC<sup>®</sup> MCUs and dsPIC<sup>®</sup> DSCs, KEELoQ<sup>®</sup> code hopping devices, Serial EEPROMs, microperipherals, nonvolatile memory and analog products. In addition, Microchip's quality system for the design and manufacture of development systems is ISO 9001:2000 certified.*

**QUALITY MANAGEMENT SYSTEM**  
**CERTIFIED BY DNV**  
**== ISO/TS 16949 ==**

### Trademarks

The Microchip name and logo, the Microchip logo, AnyRate, AVR, AVR logo, AVR Freaks, BeaconThings, BitCloud, CryptoMemory, CryptoRF, dsPIC, FlashFlex, flexPWR, Heldo, JukeBlox, KeeLoq, KeeLoq logo, Klear, LANCheck, LINK MD, maXStylus, maXTouch, MediaLB, megaAVR, MOST, MOST logo, MPLAB, OptoLyzer, PIC, picoPower, PICSTART, PIC32 logo, Prochip Designer, QTouch, RightTouch, SAM-BA, SpyNIC, SST, SST Logo, SuperFlash, tinyAVR, UNI/O, and XMEGA are registered trademarks of Microchip Technology Incorporated in the U.S.A. and other countries.

ClockWorks, The Embedded Control Solutions Company, EtherSynch, Hyper Speed Control, HyperLight Load, IntellIMOS, mTouch, Precision Edge, and Quiet-Wire are registered trademarks of Microchip Technology Incorporated in the U.S.A.

Adjacent Key Suppression, AKS, Analog-for-the-Digital Age, Any Capacitor, AnyIn, AnyOut, BodyCom, chipKIT, chipKIT logo, CodeGuard, CryptoAuthentication, CryptoCompanion, CryptoController, dsPICDEM, dsPICDEM.net, Dynamic Average Matching, DAM, ECAN, EtherGREEN, In-Circuit Serial Programming, ICSP, Inter-Chip Connectivity, JitterBlocker, KlearNet, KlearNet logo, Mindi, MiWi, motorBench, MPASM, MPF, MPLAB Certified logo, MPLIB, MPLINK, MultiTRAK, NetDetach, Omniscient Code Generation, PICDEM, PICDEM.net, PICkit, PICtail, PureSilicon, QMatrix, RightTouch logo, REAL ICE, Ripple Blocker, SAM-ICE, Serial Quad I/O, SMART-I.S., SQI, SuperSwitcher, SuperSwitcher II, Total Endurance, TSHARC, USBCheck, VariSense, ViewSpan, WiperLock, Wireless DNA, and ZENA are trademarks of Microchip Technology Incorporated in the U.S.A. and other countries.

SQTP is a service mark of Microchip Technology Incorporated in the U.S.A.

Silicon Storage Technology is a registered trademark of Microchip Technology Inc. in other countries.

GestIC is a registered trademark of Microchip Technology Germany II GmbH & Co. KG, a subsidiary of Microchip Technology Inc., in other countries.

All other trademarks mentioned herein are property of their respective companies.

© 2017, Microchip Technology Incorporated, Printed in the U.S.A., All Rights Reserved.

ISBN: 978-1-5224-0994-6



## TABLE OF CONTENTS

SIDEBRAZE .....	25	MQFN .....	475
CERDIP .....	29	UQFN .....	479
CERQUAD.....	43	VQFN.....	551
DDPAK .....	49	WQFN.....	763
SC70.....	57	XQFN.....	767
SOT-23 .....	69	X2QFN.....	771
SOT-23A.....	87	WTLA.....	779
SOT-25 .....	91	VTLA.....	783
SOT-89 .....	95	MSOP .....	793
SOT-143 .....	101	QSOP .....	807
SOT-223 .....	105	SSOP.....	815
TO-92 .....	111	TSSOP .....	823
TO-220 .....	115	TSOP .....	839
TSOT .....	119	VSOP.....	843
PDIP .....	125	LQFP .....	845
SPDIP .....	143	MQFP .....	865
PLCC .....	149	TQFP .....	877
SOP .....	169	(WL)CSP .....	921
SOIC.....	173	WLCSP.....	941
SOIJ.....	223	LLGA.....	953
DFN .....	227	VLGA.....	961
DFN-S.....	245	CABGA.....	965
PDFN.....	249	TBGA.....	969
TDFN .....	257	LFBGA.....	973
TDFN-S .....	271	TFBGA.....	989
UDFN.....	275	UFBGA .....	1033
VDFN.....	291	VFBGA.....	1037
WDFN.....	335	WFBGA.....	1053
USON .....	345	XFBGA.....	1067
WSON .....	359	VFLGA.....	1071
XSON .....	367		
X2SON .....	373		
QFN .....	385		
QFN-S .....	471		

# PACKAGING SPECIFICATION

---

NOTES:

---



---

## Package Index

---



---

### SIDEBRAZE

8-Lead Ceramic Side Brazed Dual In-Line with Window (JW) .300 .....	26
14-Lead Ceramic Side Brazed Dual In-Line with Window (JW) .300 .....	27
28-Lead Ceramic Side Brazed Dual In-Line with Window (JW) .300 .....	28

### CERDIP

8-Lead Ceramic Dual In-Line (JA) .300 Body .....	30
8-Lead Ceramic Dual In-Line with Window (JW) .300 Body .....	31
14-Lead Ceramic Dual In-Line (JD) .300 Body .....	32
14-Lead Ceramic Dual In-Line with Window (JW) .300 Body .....	33
16-Lead Ceramic Dual In-Line (JE) .300 Body .....	34
18-Lead Ceramic Dual In-Line with Window (JW) .300 Body .....	35
20-Lead Ceramic Dual In-Line with Window (JW) .300 Body .....	36
24-Lead Ceramic Dual In-Line (JG) .600 Body .....	37
28-Lead Ceramic Dual In-Line (JN) .600 Body .....	38
28-Lead Ceramic Dual In-Line with Window (JW) .300 Body .....	39
28-Lead Ceramic Dual In-Line with Window (JW) .600 Body .....	40
40-Lead Ceramic Dual In-Line (JK) .600 Body .....	41
40-Lead Ceramic Dual In-Line with Window (JW) .600 Body .....	42

### CERQUAD

68-Lead Ceramic Leaded (CL) Chip Carrier with Window .....	44
68-Lead Ceramic Leaded (CL) Chip Carrier with Window Square Land Pattern .....	45
84-Lead Ceramic Leaded (CL) Chip Carrier with Window .....	46
84-Lead Ceramic Leaded (CL) Chip Carrier with Window Square Land Pattern .....	47

### DDPAK

3-Lead Plastic (EB) .....	50
3-Lead Plastic (EB) Land Pattern .....	51
5-Lead Plastic (ET) .....	52
5-Lead Plastic (ET) Land Pattern .....	53
7-Lead Plastic (EK) .....	54
7-Lead Plastic (EK) Land Pattern .....	55

### SC70

3-Lead Plastic Small Outline Transistor (LB) .....	58
3-Lead Plastic Small Outline Transistor (LB) Land Pattern .....	60
5-Lead Plastic Small Outline Transistor (LT) .....	61
5-Lead Plastic Small Outline Transistor (LT) Land Pattern .....	63
5-Lead Plastic Small Outline Transistor (LTY) .....	64
5-Lead Plastic Small Outline Transistor (LTY) Land Pattern .....	65
6-Lead Plastic Small Outline Transistor (LT) .....	66
6-Lead Plastic Small Outline Transistor (LT) Land Pattern .....	68

---



---

## Package Index

---



---

### SOT-23

3-Lead Plastic Small Outline Transistor (NB) .....	70
3-Lead Plastic Small Outline Transistor (NB) Land Pattern.....	71
3-Lead Plastic Small Outline Transistor (TT).....	72
3-Lead Plastic Small Outline Transistor (TT) Land Pattern .....	73
5-Lead Plastic Small Outline Transistor (CT) .....	74
5-Lead Plastic Small Outline Transistor (CT) Land Pattern.....	76
5-Lead Plastic Small Outline Transistor (OT) .....	77
5-Lead Plastic Small Outline Transistor (OT) Land Pattern.....	79
6-Lead Plastic Small Outline Transistor (CH, CHY) .....	80
6-Lead Plastic Small Outline Transistor (CH, CHY) Land Pattern.....	82
6-Lead Plastic Small Outline Transistor (OT, OTY) .....	83
6-Lead Plastic Small Outline Transistor (OT, OTY) Land Pattern.....	85

### SOT-23A

3-Lead Plastic Small Outline Transistor (CB) .....	88
3-Lead Plastic Small Outline Transistor (CB) Land Pattern.....	89

### SOT-25

5L Plastic Small Outline Transistor Package (5A) .....	92
5L Plastic Small Outline Transistor Package (5A) Land Pattern .....	94

### SOT-89

3-Lead Plastic Small Outline Transistor (MB).....	96
3-Lead Plastic Small Outline Transistor (MB) Land Pattern .....	98
5-Lead Plastic Small Outline Transistor Header (MT) .....	99
5-Lead Plastic Small Outline Transistor Header (MT) Land Pattern.....	100

### SOT-143

4-Lead Plastic Small Outline Transistor (RC).....	102
4-Lead Plastic Small Outline Transistor (RC) Land Pattern .....	103

### SOT-223

3-Lead Plastic Small Outline Transistor (DB) .....	106
3-Lead Plastic Small Outline Transistor (DB) Land Pattern.....	107
5-Lead Plastic Small Outline Transistor (DC) .....	108
5-Lead Plastic Small Outline Transistor (DC) Land Pattern .....	109

### TO-92

3-Lead Plastic Transistor Outline (TO) .....	112
3-Lead Plastic Transistor Outline (ZB).....	113

---



---

## Package Index

---



---

### TO-220

3-Lead Plastic Transistor Outline (AB) .....	116
5-Lead Plastic Transistor Outline (AT) .....	117

### TSOT

5-Lead Plastic Thin Small Outline Transistor (OS) .....	120
5-Lead Plastic Thin Small Outline Transistor (OS) Land Pattern .....	121
6-Lead Thin Small Outline Transistor (OS) .....	122

### PDIP

8-Lead Plastic Dual In-Line (P) 300 .....	126
8-Lead Plastic Dual In-Line (PA) 300 mil Body .....	128
14-Lead Plastic Dual In-Line (P) 300 .....	130
14-Lead Plastic Dual In-Line (PD) 300 .....	131
16-Lead Plastic Dual In-Line (P) 300 .....	132
16-Lead Plastic Dual In-Line (PE) 300 .....	133
18-Lead Plastic Dual In-Line (P) 300 .....	134
20-Lead Plastic Dual In-Line (P) 300 .....	135
24-Lead Plastic Dual In-Line (P) 600 .....	136
24-Lead Plastic Dual In-Line (PG) 600 .....	137
28-Lead Plastic Dual In-Line (P) 600 .....	138
28-Lead Plastic Dual In-Line (PI) 600 .....	139
40-Lead Plastic Dual In-Line (P) 600 .....	140
40-Lead Plastic Dual In-Line (PL) 600 .....	141
64-Lead Shrink Plastic Dual In-Line (SP) 750 .....	142

### SPDIP

24-Lead Skinny Plastic Dual In-Line (PF) 300 .....	144
24-Lead Skinny Plastic Dual In-Line (SP) 300 .....	145
28-Lead Skinny Plastic Dual In-Line (PJ) 300 .....	146
28-Lead Skinny Plastic Dual In-Line (SP) 300 .....	147

### PLCC

20-Lead Plastic Leaded Chip Carrier (L) .....	150
20-Lead Plastic Leaded Chip Carrier (L) Square Land Pattern .....	151
28-Lead Plastic Leaded Chip Carrier (L) .....	152
28-Lead Plastic Leaded Chip Carrier (L) Square Land Pattern .....	153
28-Lead Plastic Leaded Chip Carrier (LI) .....	154
28-Lead Plastic Leaded Chip Carrier (LI) Square Land Pattern .....	155
32-Lead Plastic Leaded Chip Carrier (L) .....	156
32-Lead Plastic Leaded Chip Carrier (L) Rectangle Land Pattern .....	157
44-Lead Plastic Leaded Chip Carrier (L) .....	158

---



---

## Package Index

---



---

44-Lead Plastic Leaded Chip Carrier (L) Square Land Pattern.....	159
44-Lead Plastic Leaded Chip Carrier (LW).....	160
44-Lead Plastic Leaded Chip Carrier (LW) Square Land Pattern.....	161
68-Lead Plastic Leaded Chip Carrier (L).....	162
68-Lead Plastic Leaded Chip Carrier (L) Square Land Pattern.....	163
68-Lead Plastic Leaded Chip Carrier (LS).....	164
68-Lead Plastic Leaded Chip Carrier (LS) Square Land Pattern.....	165
84-Lead Plastic Leaded Chip Carrier (L).....	166
84-Lead Plastic Leaded Chip Carrier (L) Square Land Pattern.....	167

### SOP

---

8-Lead Thermally Enhanced Plastic Outline (SE) Narrow 3.90 mm Body.....	170
8-Lead Thermally Enhanced Plastic Small Outline (SE) Narrow 3.90 mm Land Pattern.....	172

### SOIC

---

8-Lead Small Outline Integrated Circuit (7HX) .150 in. with 1.65x1.65 Exposed Pad.....	174
8-Lead Small Outline Integrated Circuit (7HX) .150 in. with 1.65x1.65 Exposed Pad Land Pattern.....	176
8-Lead Small Outline Integrated Circuit (5DX) .150 In Body with 3.30x2.41 Exposed Pad.....	177
8-Lead Small Outline Integrated Circuit (5DX) .150 In Body with 3.30x2.41 Exposed Pad Land Pattern.....	179
8-Lead Plastic Small Outline (SN) Narrow 3.9.....	180
8-Lead Plastic Small Outline (SN) Narrow 3.90 Land Pattern.....	182
8-Lead Plastic Small Outline (OA) Narrow 3.90.....	183
8-Lead Plastic Small Outline (OA) Narrow 3.90 Land Pattern.....	185
8-Lead Thermally Enhanced Plastic Small Outline (SE) Narrow 3.9 Body.....	186
8-Lead Thermally En Plastic Small Outline (SE) Narrow 3.9 Land Pattern.....	188
14-Lead Plastic Small Outline (SL) Narrow 3.9 Body.....	189
14-Lead Plastic Small Outline (SL) Narrow 3.90 Land Pattern.....	191
14-Lead Plastic Small Outline (OD) Narrow 3.9 Body.....	192
14-Lead Plastic Small Outline (OD) Narrow 3.90 Land Pattern.....	194
16-Lead Plastic Small Outline (SL) Narrow 3.9 Body.....	195
16-Lead Plastic Small Outline (SL) Narrow 3.90 Land Pattern.....	197
16-Lead Plastic Small Outline (SO) Wide 7.5 Body.....	198
16-Lead Plastic Small Outline (SO) Wide 7.50 Land Pattern.....	200
16-Lead Plastic Small Outline (OE) Wide 7.5 Body.....	201
16-Lead Plastic Small Outline (OE) Wide 7.50 Land Pattern.....	203
18-Lead Plastic Small Outline (SO) Wide 7.5 Body.....	204
18-Lead Plastic Small Outline (SO) Wide 7.5 Land Pattern.....	206
20-Lead Plastic Small Outline (SO) Wide 7.5 Body.....	207
20-Lead Plastic Small Outline (SO) Wide 7.50 Land Pattern.....	209
24-Lead Plastic Small Outline (SO) Wide 7.5 Body.....	210
24-Lead Plastic Small Outline (SO) Wide 7.50 Land Pattern.....	212
24-Lead Plastic Small Outline (OG) Wide 7.5 Body.....	213

---



---

## Package Index

---



---

24-Lead Plastic Small Outline (OG) Wide 7.50 Land Pattern.....	215
28-Lead Plastic Small Outline (SO) Wide 7.5 Body .....	216
28-Lead Plastic Small Outline (SO) Wide 7.50 Land Pattern.....	218
28-Lead Plastic Small Outline (OI) Wide 7.5 Body.....	219
28-Lead Plastic Small Outline (OI) Wide 7.50 Land Pattern .....	221

### SOIJ

8-Lead Plastic Small Outline (SM) Medium 5.28 mm.....	224
8-Lead Plastic Small Outline (SM) Medium 5.28 Land Pattern .....	226

### DFN

6-Lead Plastic Dual Flat No Lead Package (MAY) 2x2x0.9 mm Body .....	228
6-Lead Plastic Dual Flat No Lead Package (MA) 2x2x0.9 Land Pattern.....	230
6-Lead Plastic Dual Flat No Lead Package (ME) 2x3x0.9 .....	231
6-Lead Plastic Dual Flat No Lead Package (MH) 3x3x0.9 .....	232
8-Lead Plastic Dual Flat No Lead Package (MC) 2x3x0.9 .....	233
8-Lead Plastic Dual Flat No Lead Package (MC) 2x3x0.9 Land Pattern.....	234
8-Lead Plastic Dual Flat No Lead Package (MF) 3x3x0.9.....	235
8-Lead Plastic Dual Flat No Lead Package (MF) 3x3x0.9 Land Pattern .....	237
8-Lead Plastic Dual Flat No Lead Package (MD) 4x4x0.9 .....	238
8-Lead Plastic Dual Flat No Lead Package (MD) 4x4x0.9 Land Pattern.....	240
10-Lead Plastic Dual Flat No Lead Package (MF) 3x3x0.9 Body .....	241
10-Lead Plastic Dual Flat No Lead Package (MF) 3x3x0.9 Land Pattern .....	243

### DFN-S

8-Lead Plastic Dual Flat No Lead Package (MF) 6x5 Punch Singulated .....	246
8-Lead Plastic Dual Flat No Lead Package (MF) 6x5 .....	247
8-Lead Plastic Dual Flat No Lead Package (MF) 6x5 Land Pattern.....	248

### PDFN

8-Lead Power Dual Flat No Lead Package (MF) 5x6x1 .....	250
8-Lead Power Dual Flat No Lead Package (MF) 5x6x1 Land Pattern .....	252
8-Lead Power Dual Flat No Lead Package (LC) 3.3x3.3x1.....	253
8-Lead Power Dual Flat No Lead Package (LC) 3.3x3.3x1 Land Pattern.....	255

### TDFN

6-Lead Plastic Thin Dual Flat No Lead Package (MY) 2x2x0.8 Body .....	258
6-Lead Plastic Thin Dual Flat No Lead Package (MY) 2x2x0.8 Body.....	260
8-Lead Plastic Dual Flat (MN) 2x3x0.8 mm with 1.4x1.3 Exposed Pad .....	262
8-Lead Plastic Dual Flat (MN) 2x3x0.8 mm with 1.4x1.3 Exposed Pad Land Pattern.....	264
8-Lead Plastic Dual Flat (MNY) 2x3x0.8 mm with 1.4x1.3 Exposed Pad.....	265
8-Lead Plastic Dual Flat (MNY) 2x3x0.8 mm with 1.4x1.3 Exposed Pad Land Pattern .....	267
10-Lead Thin Plastic Dual Flat No Lead Package (MN) 3x3x0.8 Body .....	268

---



---

## Package Index

---



---

### TDFN-S

8-Lead Plastic Very Very Thin Small Outline (MF) 5x6 mm.....	272
8-Lead Plastic Very Very Thin Small Outline (MF) 5x6 mm Land Pattern .....	274

### UDFN

8-Lead Plastic Dual Flat No Lead Package (MU) 2x3x0.5 .....	276
8-Lead Plastic Dual Flat No Lead Package (MU) 2x3x0.5 Land Pattern.....	277
8-Lead Plastic Ultra Thin Small Outline No Lead Package (NP) 2x3 mm Body.....	278
8-Lead Plastic Ultra Thin Small Outline No Lead Package (NP) 2x3 mm Body Land Pattern .....	280
8-Lead Plastic Ultra Thin Small Outline No Lead Package (PRX) 2x3 mm Body .....	281
8-Lead Plastic Ultra Thin Small Outline No Lead Package (PRX) 2x3 mm Body Land Pattern.....	283
8-Lead Ultra Thin Plastic Dual Flat No Lead Package (RF) 3x3x0.50 mm Body .....	284
8-Lead Ultra Thin Plastic Dual Flat No Lead Package (RF) 3x3x0.50 mm Body Land Pattern.....	286
10-Lead Plastic Ultra Thin Dual Flat No Lead (NA[Y]) 3x3x0.5 mm Body.....	287
10-Lead Ultra Thin Dual Flatpak No Lead (NA[Y]) 3x3 mm Body Land Pattern.....	289

### VDFN

4-Lead Very Thin Plastic Dual Flatpack (H4A) 3.2x2.5 mm Body .....	292
4-Lead Very Thin Plastic Dual Flatpack (H4A) 3.2x2.5 mm Body Land Pattern.....	294
6-Lead Very Thin Dual Flatpack (J7A) 2.5x2 mm Body.....	295
6-Lead Very Thin Dual Flatpack (J7A) 2.5x2 mm Body Land Pattern.....	297
6-Lead Very Thin Plastic Dual Flatpack (H5A) 3.2x2.5 mm Body .....	298
6-Lead Very Thin Plastic Dual Flatpack (H5A) 3.2x2.5 mm Body Land Pattern.....	300
6-Lead Very Thin Quad Flat (H8A) 7x5 mm with 2.8x1.8 Exposed Pad.....	301
6-Lead Very Thin Quad Flat (H8A) 7x5 mm with 2.8x1.8 Exposed Pad Land Pattern .....	303
8-Lead Very Thin Flat Dual No Lead (LZ) 2x2 mm with 1.7x0.9 Exposed Pad .....	304
8-Lead Very Thin Flat Dual No Lead (LZ) 2x2 mm with 1.7x0.9 Exposed Pad Land Pattern.....	306
8-Lead Very Thin Plastic Dual Flat (J8A) 2x2 mm with 1.7x0.9 mm Exposed Pad .....	307
8-Lead Very Thin Plastic Dual Flat (J8A) 2x2 mm with 1.7x0.9 mm Exposed Pad Land Pattern.....	309
8-Lead Very Thin Plastic Dual Flat No Lead Package (8Q) 2x3.....	310
8-Lead Very Thin Plastic Dual Flat No Lead Package (8Q) 2x3 Land Pattern .....	312
8-Lead Very Thin Plastic Dual Flat (JEA) 3x2 mm with Dimpled Wettable Flanks .....	313
8-Lead Very Thin Plastic Dual Flat (JEA) 3x2 mm with Dimpled Wettable Flanks Land Pattern .....	315
8-L Very Thin Plastic Dual Flat (9U) 6x5 mm with Dual Exposed Pads.....	316
8-L Very Thin Plastic Dual Flat (9U) 6x5 mm with Dual Exposed Pads Land Pattern .....	318
10-Lead Very Thin Plastic Dual Flat (9R) 2.5x2.0 mm Body .....	319
10-Lead Very Thin Plastic Dual Flat (9R) 2.5x2.0 mm Body Land Pattern.....	321
10-Lead Very Thin Plastic Dual Flat No Lead Package (9Q) 3x3.....	322
10-Lead Very Thin Plastic Dual Flat No Lead Package (9Q) 3x3 Land Pattern .....	324
11-Lead Very Thin Plastic Dual Flat Package (K4A) 6x5 mm with Dual Fused Exposed Pads .....	325
11-Lead Very Thin Plastic Dual Flat Package (K4A) 6x5 mm with Dual Fused Exposed Pads Land Pattern.....	327
14-Lead Very Thin Plastic Dual Flat No Lead (4S) 4.5x3.0 mm Body.....	328



---



---

## Package Index

---



---

14-Lead Very Thin Plastic Dual Flat No Lead (4S) 4.5x3.0 mm Body Land Pattern .....	330
14-Lead Very Thin Plastic Quad Flat (JHA) 4.5x3 mm with Dimpled Wettable Flanks .....	331
14-Lead Very Thin Plastic Quad Flat (JHA) 4.5x3 mm with Dimpled Wettable Flanks Land Pattern .....	333

### WDFN

8-Lead Very Very Thin Plastic Dual Flat No Lead (RW) 2x2 .....	336
8-Lead Very Very Thin Plastic Dual Flat No Lead (RW) 2x2 Land Pattern.....	338
8-Lead Plastic Very Very Thin Small Outline (MF) 5x6 mm.....	339
8-Lead Plastic Very Very Thin Small Outline (MF) 5x6 mm Land Pattern .....	341
8-Lead Very Very Thin Small Outline No Lead (MN) 6x8 mm .....	342
8-Lead Very Very Thin Small Outline No Lead (MN) 6x8 mm Land Pattern.....	344

### USON

8-Lead Ultra Thin Small Outline (ND) 2x2 Body SST Legacy .....	346
8-Lead Ultra Thin Small Outline (ND) 2x2 Body SST Legacy Land Pattern.....	348
8-Lead Plastic Ultra Thin Small Outline No Lead Package (NP) 2x3 mm Body.....	349
8-Lead Plastic Ultra Thin Small Outline No Lead Package (NP) 2x3 mm Body Land Pattern .....	351
8-Lead Plastic Ultra Thin Small Outline No Lead Package (PRX) 2x3 mm Body .....	352
8-Lead Plastic Ultra Thin Small Outline No Lead Package (PRX) 2x3 mm Body Land Pattern.....	354
8-Terminal Plastic Ultra Thin Dual Flat No Lead Package (UB) 4x3x0.55 mm Body .....	355
8-Terminal Plastic Ultra Thin Dual Flat No Lead Package (UB) 4x3x0.55 mm Body Land Pattern.....	357

### WSON

8-Lead Very Very Thin Small Outline No Lead (MN) 6x8 mm .....	360
8-Lead Very Very Thin Small Outline No Lead (MN) 6x8 mm Footprint.....	362
8-Lead Plastic Very Very Thin Small Outline (MF) 5x6 mm.....	363
8-Lead Plastic Very Very Thin Small Outline (MF) 5x6 mm Land Pattern .....	365

### XSON

8-Lead Extremely Thin Small Outline No-Leads (NF) 2x2x0.45 mm Body .....	368
8-Lead Extremely Thin Small Outline No-Leads (QX8E) 2x2x0.45 mm Body.....	370

### X2SON

6-Lead Plastic Super Thin Small Outline No Lead (NR) 1.5x1.5x0.4 mm Body.....	374
8-Lead Plastic Super-Thin Dual Small Outline No-Lead (8X) 1.5x1.5.....	376
8-Lead Plastic Super-Thin Dual Small Outline No-Lead (8X) 1.5x1.5 Land Pattern .....	378
8-Terminal Super-Thin Plastic Small Outline (NR) 2x2x0.4 mm.....	379
8-Terminal Super-Thin Plastic Small Outline No Lead Package (NR) 2x2x0.4 mm (Max) Body Land Pattern .....	381
8-Terminal Super-Thin Plastic Small Outline (XX8E) 2x2x0.4 mm.....	382
8-Terminal Super-Thin Plastic Small Outline No Lead Package (XX8E) 2x2x0.4 mm (Max) Body Land Pattern .....	384

---



---

## Package Index

---



---

### QFN

16-Lead Plastic Quad Flat No Lead Package (NG) 3x3x0.9 mm Body.....	386
16-Lead Plastic Quad Flat No Lead Package (NG) 3x3x0.9 mm Land Pattern .....	388
16-Lead Plastic Quad Flat No Lead Package (MG) 3x3x0.9.....	389
16-Lead Plastic Quad Flat No Lead Package (MG) 3x3x0.9 mm Land Pattern .....	391
16-L Plastic Quad Flat (ML) 4x4x0.9 mm Body.....	392
16-L Plastic Quad Flat (ML) 4x4x0.9 mm Body Land Pattern .....	394
16-Lead Plastic Quad Flat (8E) 4x4x0.9 mm Body .....	395
16-Lead Plastic Quad Flat No Lead Package (8E) 4x4x0.9 mm Body Land Pattern .....	397
16-Lead Plastic Quad Flat No Lead Package (FX) 4x4x0.9 mm Body.....	398
16-Lead Plastic Quad Flat No Lead Package (FX) 4x4x0.9 mm Body Land Pattern .....	400
20-Lead Plastic Quad Flat No Lead Package (ML) 4x4x0.9 .....	401
20-Lead Plastic Quad Flat No Lead Package (ML) 4x4 Land Pattern.....	402
24-Lead Plastic Quad Flat No Lead Package (MJ) 4x4x0.9.....	403
24-Lead Plastic Quad Flat No Lead Package (MJ) 4x4 Land Pattern.....	404
24-Lead Plastic Quad Flat No Lead (RU) 4x4 mm with 2.5x2.5 mm Exposed Pad Punch Singulated .....	405
24-Lead Plastic Quad Flat No Lead (RU) 4x4 mm with 2.5x2.5 mm Exposed Pad Punch Singulated Land Pattern .....	407
24-Lead Plastic Quad Flat No Lead (LY) 5x5x1.0 mm Body .....	408
24-Lead Plastic Quad Flat No Lead (LY) 5x5x1.0 mm Land Pattern.....	410
28-Lead Plastic Quad Flat No Lead Package (MK) 4x4x0.9 .....	411
28-Lead Plastic Quad Flat No Lead Package (MK) 4x4x0.9 Land Pattern .....	412
28-Lead Plastic Quad Flat No Lead Package (MQ) 5x5x0.9 mm Body .....	413
28-Lead Plastic Quad Flat No Lead Package (MQ) 5x5 Land Pattern.....	415
28-Lead Plastic Quad Flat No Lead Package (MQY) 5x5x0.9 mm Body .....	416
28-Lead Plastic Quad Flat No Lead Package (MQY) 5x5x0.9 mm Body Land Pattern .....	418
28-Lead Plastic Quad Flat No Lead Package (ML) 6x6 mm with 0.55 Terminal .....	419
28-Lead Plastic Quad Flat No Lead Package (ML) 6x6 with 0.55 Terminal Land Pattern.....	421
32-L Plastic Quad Flat (3E) 5x5 mm Body 0.40 mm Terminals with 3.3x3.3 EP - Punch Singulated Dimpled .....	422
32-L Plastic Quad Flat (3E) 5x5 mm Body 0.40 mm Terminals with 3.3x3.3 EP - Punch Singulated Dimpled Land Pattern.....	424
36-Lead Plastic Quad Flat (4E) 6x6 mm Body with 3.7x3.7 mm Exposed Pad Punch 0.40 mm Dimpled Terminals.....	425
36-Lead Plastic Quad Flat (4E) 6x6 mm Body with 3.7x3.7 mm Exposed Pad Punch 0.40 mm Dimpled Terminals Land Pattern .....	427
40-Lead Plastic Quad Flat No Lead (RR) 6x6 mm with 4.1x4.1 mm Exposed Pad Punch Singulated .....	428
40-Lead Plastic Quad Flat, No Lead Package (RR) 6x6 mm with 4.1x4.1 mm Exposed Pad Punch Singulated Land Pattern .....	430
40-Lead Plastic Quad Flat No Lead (ML) 6x6X0.9.....	431
40-Lead Plastic Quad Flat No Lead (ML) 6x6X0.9 Land Pattern .....	433
40-Lead Plastic Quad Flat (MP) 5x5 mm Body with 3.5 Exposed Pad .....	434
40-Lead Plastic Quad Flat (MP) 5x5 mm Body with 3.5 Exposed Pad Land Pattern.....	436
40-Lead Plastic Quad Flat (MP) 5x5 mm Body with 3.7 Exposed Pad .....	437
40-Lead Plastic Quad Flat (MP) 5x5 mm Body with 3.7 Exposed Pad Land Pattern.....	439
44-Lead Plastic Quad Flat No Lead Package (ML) 8x8 .....	440
44-Lead Plastic Quad Flat No Lead Package (ML) 8x8 Land Pattern.....	442

---



---

## Package Index

---



---

48-Lead Plastic Quad Flat (5E) 6x6 mm Body with 5.1x5.1 mm Exposed Pad Punch 0.40 mm Dimpled Terminals.....	443
48-Lead Plastic Quad Flat (5E) 6x6 mm Body with 5.1x5.1 mm Exposed Pad Punch 0.40 mm Dimpled Terminals Land Pattern .....	445
64-Lead Very Thin Plastic Quad Flat (MR) 9x9x0.9 mm with 7.15x7.15 Exposed Pad.....	446
64-Lead Very Thin Plastic Quad Flat (MR) 9x9x0.9 mm with 7.15x7.15 Exposed Pad Land Pattern.....	448
64-Lead Very Thin Plastic Quad Flat (R4X) 9x9x0.9 mm with 7.15x7.15 Exposed Pad .....	449
64-Lead Very Thin Plastic Quad Flat (R4X) 9x9x0.9 mm with 7.15x7.15 Exposed Pad Land Pattern.....	451
64-Lead Plastic Quad Flat No Lead Package (MR) 9x9x0.9 mm Body with 5.40 Exposed Pad.....	452
64-Lead Plastic Quad Flat (MR) 9x9x0.9mm with 0.40 contact and 5.40 Exposed Pad Land Pattern .....	454
64-Lead Plastic Quad Flat No Lead Package (MR) 9x9x0.9 Body with 7.70 Exposed Pad.....	455
64-Lead Plastic Quad Flat No Lead (MR) 9x9x0.9 mm with 0.40 mm Contact and 7.70x7.70 mm Exposed Pad.....	457
64-Terminal Plastic Quad Flat Pack No Lead (RG) 9x9x0.9 mm Body Saw Singulated .....	458
64-Lead Very Thin Plastic Quad Flat No Lead (RG) 9x9x1.0 mm Body 4.7 Exposed Pad Land Pattern.....	460
72-Lead Plastic Quad Flat No Lead (6E) 10x10 mm with Exposed Pad Punch Singulated Dimpled .....	461
72-Lead Plastic Quad Flat No Lead (6E) 10x10 mm with Exposed Pad Punch Singulated Dimpled Land Pattern.....	463
80-Lead Plastic Quad Flat (6FX) 11x11x0.9 mm Body.....	464
80-Lead Plastic Quad Flat (6FX) 11x11x0.9 mm Body Land Pattern .....	466
80-Lead Plastic Quad Flat (8FX) 11x11x0.9 mm Body.....	467
80-Lead Plastic Quad Flat (8FX) 11x11x0.9 mm Body Land Pattern.....	469

### **QFN-S**

28-Lead Plastic Quad Flat No Lead Package (MM) 6x6x0.9 with 0.40 Terminal .....	472
28-Lead Plastic Quad Flat No Lead Package (MM) 6x6x0.9 Land Pattern.....	474

### **MQFN**

20-Lead More Thin Plastic Quad Flat, No Lead Package (NU) 5x5x1.0 mm Body.....	476
20-Lead More Thin Plastic Quad Flat, No Lead Package (NU) 5x5x1.0 mm Body Land Pattern .....	478

### **UQFN**

4-Lead Plastic Ultra Thin Quad Flatpack No Leads (5X) 1x1x0.6 mm .....	480
4-Lead Plastic Ultra Thin Quad Flatpack No Leads (5X) 1x1x0.6 mm Land Pattern .....	482
10-Lead Ultra Thin Plastic Quad Flat Package (2V) 1.3x1.8x0.6 mm Body.....	483
10-Lead Ultra Thin Plastic Quad Flat Package (2V) 1.3x1.8x0.6 mm Body Land Pattern .....	485
10-Lead Ultra Thin Plastic Quad Flat Package (3V) 1.6x2.1 Body mm.....	486
10-Lead Ultra Thin Plastic Quad Flat Package (3V) 1.6x2.1 Body Land Pattern .....	488
12-Lead Ultra Thin Quad Flat (QM) 2x2 mm Body SST Legacy .....	489
12-Lead Ultra Thin Quad Flat (QM) 2x2 mm Body SST Legacy Land Pattern.....	491
16-Lead Plastic Ultra Thin Quad Flat No Lead Package (MV) 2.5x2.5x0.6 mm Body .....	492
16-Lead Ultra Thin Quad Flat Pack (MV) 3x3x0.50 mm Body .....	494
16-Lead Ultra Thin Quad Flat Pack (MV) 3x3x0.50 mm Body Land Pattern.....	496
16-Lead Ultra Thin Quad Flat No Lead Package (UC) 3x3x0.5 mm Body.....	497
16-Lead Ultra Thin Quad Flat No Lead Package (UC) 3x3x0.55 mm Body Land Pattern .....	499
16-Lead Ultra Thin Quad Flat No Lead Package (UD) 3x3x0.55 mm Body .....	500

---



---

## Package Index

---



---

16-Lead Ultra Thin Quad Flat No Lead Package (UD) 3x3x0.55 mm Body Land Pattern .....	502
16-Lead Ultra Thin Plastic Quad Flat No Lead Package (JQ) 4x4x0.5 mm Body .....	503
16-Lead Ultra Thin Plastic Quad Flat No Lead Package (JQ) 4x4x0.5 mm Body Land Pattern .....	505
20-Lead Ultra Thin Quad Flat (NC) 3x3 mm SST Legacy .....	506
20-Lead Ultra Thin Quad Flat (NC) 3x3 mm SST Legacy Land Pattern .....	508
20-Lead Ultra Thin Plastic Quad Flat No Lead Package (JP) 3x3x0.5 mm Body .....	509
20-Lead Ultra Thin Plastic Quad Flat No Lead Package (JP) 3x3x0.5 mm Body Land Pattern .....	511
20-Lead Ultra Thin Plastic Quad Flat No Lead Package (GZ) 4x4x0.5 mm Body .....	512
20-Lead Ultra Thin Plastic Quad Flat No Lead Package (GZ) 4x4x0.5 mm Body Land Pattern .....	514
20-Lead Ultra Thin Quad Flat Pack No Lead (GN) 4x4x0.55 mm .....	515
28-Lead Plastic Ultra Thin Quad Flat No Lead Package (MV) 4x4x0.5 mm Body .....	517
28-Lead Ultra Thin Plastic Quad Flat No Lead Package (MV) 4x4 Body Land Pattern .....	519
28-L Ultra Thin Plastic Quad Flat (PW) 4x4x0.6 Body with Corner Anchors .....	520
28-L Ultra Thin Plastic Quad Flat (PW) 4x4x0.6 Body with Corner Anchors Land Pattern .....	522
28-Lead Ultra Thin Plastic Quad Flat, No Lead Package (M6) 4x4x0.6 mm Body and Corner Anchors .....	523
28-L Ultra Thin Plastic Quad Flat (M6) 4x4x0.6 Body with Corner Anchors Land Pattern .....	525
28-L Plastic Quad Flat No Lead (MX) 6x6x0.5 Ultra-Thin 0.4x0.6 with corner anchors .....	526
28-L Plastic Quad Flat No Lead (MX) 6x6x0.5 Ultra-Thin 0.4x0.6 with corner anchors Land Pattern .....	528
28-Lead Ultra Thin Quad Flat (2N) 6x6x0.55 mm - 4.65x4.65 Exposed Pad Corner Anchors .....	529
28-Lead Ultra Thin Quad Flat (2N) 6x6x0.55 mm - 4.65x4.65 Exposed Pad Corner Anchors Land Pattern .....	531
36-Lead Ultra Thin Plastic Quad (M5) 5x5 mm with Corner Anchors .....	532
36-Lead Ultra Thin Plastic Quad (M5) 5x5 mm with Corner Anchors Land Pattern .....	534
36-Lead Ultra Thin Plastic Quad (SCX) 5x5 mm with Corner Anchors .....	535
36-Lead Ultra Thin Plastic Quad (SCX) 5x5 mm with Corner Anchors Land Pattern .....	537
40-Lead Plastic Ultra Thin Quad Flat (MV) 5x5 mm .....	538
40-Lead Plastic Ultra Thin Quad Flat No Lead (MV) 5x5 Land Pattern .....	540
48-Lead Plastic Ultra Thin Quad Flat No Lead (MV) 6x6x0.5 Body .....	541
48-Lead Ultra Thin Plastic Quad Flat (MV) 6x6 Land Pattern .....	543
48-Lead Ultra Thin Plastic Quad Package (M4) 6x6 mm Corner Anchors 4.6x4.6 Exposed Pad .....	544
48-Lead Ultra Thin Plastic Quad Package (M4) 6x6 mm Corner Anchors 4.6x4.6 Exposed Pad Land Pattern .....	546
48-Lead Ultra Thin Plastic Quad Package (PTX) 6x6 mm Corner Anchors 4.6x4.6 Exposed Pad .....	547
48-Lead Ultra Thin Plastic Quad Package (PTX) 6x6 mm Corner Anchors 4.6x4.6 Exposed Pad Land Pattern .....	549

### VQFN

10-Lead Very Thin Quad Flat (MRA) 2x2 mm with Fused Exposed Pad .....	552
10-Lead Very Thin Quad Flat (MRA) 2x2 mm with Fused Exposed Pad Land Pattern .....	554
12-Lead Very Thin Plastic Quad Flat No Lead Package (UL) 4x4 .....	555
12-Lead Very Thin Plastic Quad Flat No Lead Package (UL) 4x4 Land Pattern .....	557
16-Lead Plastic Quad Flat (8N) 3x3x1.0 mm Wettable Flanks Stepped 0.35 Terminal Length .....	558
16-Lead Plastic Quad Flat (8N) 3x3x1.0 mm Wettable Flanks Stepped 0.35 Terminal Length Land Pattern .....	560
16-Lead Very Thin Quad Flat (MG) 3x3 mm with 1.1x1.1 mm Exposed Pad .....	561
16-Lead Very Thin Quad Flat (MG) 3x3 mm with 1.65x1.65 mm Exposed Pad .....	563

---



---

## Package Index

---



---

16-Lead Very Thin Quad Flat (MG) 3x3 mm with 1.65x1.65 mm Exposed Pad Land Pattern .....	565
16-Lead Very Thin Plastic Quad Flat No Lead Package (AP) 4x4 .....	566
16-Lead Very Thin Plastic Quad Flat No Lead Package (AP) 4x4 Land Pattern.....	568
16-Lead Plastic Quad Flat (7N) 4x4x1.0 mm Wettable Flanks Stepped 0.40 Terminal Length.....	569
16-Lead Plastic Quad Flat (7N) 4x4x1.0 mm Wettable Flanks Stepped 0.40 Terminal Length Land Pattern .....	571
16-Lead Very Thin Quad Flat No Lead Package (7E) 4x4 mm Body with 2.1x2.1 Exposed Pad Punch Dimpled .....	572
16-Lead Very Thin Quad Flat No Lead Package (7E) 4x4 mm Body with 2.1x2.1 Exposed Pad Punch Dimpled Land Pattern .....	574
16-Lead Quad Flat No Lead (8N) 3x3x1.0 Stepped 0.35 Terminal Length .....	575
16-Lead Quad Flat No Lead (8N) 3x3x1.0 Stepped 0.35 Terminal Length Land Pattern.....	577
16-Lead Quad Flat No Lead (7N) 4x4x1.0 Stepped 0.40 Terminal Length .....	578
16-Lead Quad Flat No Lead (7N) 4x4x1.0 Stepped 0.40 Terminal Length Land Pattern.....	580
20-Lead Very Thin Plastic Quad Flat (LXX) 3x3x0.9 mm Internal Flip Chip.....	581
20-Lead Very Thin Plastic Quad Flat (LXX) 3x3x0.9 mm Internal Flip Chip Land Pattern .....	583
20-Lead Plastic Quad Flat (6N) 4x4x1.0 mm Wettable Flanks Stepped 0.40 Terminal Length.....	584
20-Lead Plastic Quad Flat (6N) 4x4x1.0 mm Wettable Flanks Stepped 0.40 Terminal Length Land Pattern .....	586
20-Lead Plastic Quad Flat No Lead (ML) 5x5x1.0 mm Body with 0.40 mm Contact Length Land Pattern.....	589
20-Lead Plastic Quad Flat No Lead (MQ) 5x5x1.0 mm Body with 0.40 mm Contact Length.....	590
20-Lead Plastic Quad Flat No Lead (MQ) 5x5x1.0 mm Body with 0.40 mm Contact Length Land Pattern.....	592
24-Lead Very Thin Quad Flat (NVA) 3x4 mm with Multiple Exposed Pad Wettable Flanks .....	593
24-Lead Very Thin Quad Flat (NVA) 3x4 mm with Multiple Exposed Pad Wettable Flanks Land Pattern .....	595
24-Lead Very Thin Quad Flat (MJ) 4x4x0.9.....	596
24-Lead Very Thin Quad Flat (MJ) 4x4x0.9 Land Pattern .....	598
24-Lead Very Thin Quad Flat (MJ) 4x4x0.9 SMSC Legacy S4QFN.....	599
24-Lead Very Thin Quad Flat (MJ) 4x4x0.9 SMSC Legacy S4QFN Land Pattern .....	601
24-Lead Plastic Quad Flat No Lead (LY) 5x5x1.0 mm .....	602
24-Lead Plastic Quad Flat No Lead (LY) 5x5x1.0 mm Footprint .....	604
28-L Very Thin Plastic Quad Flat Pack (PV) 5x5x0.9 mm .....	605
28-L Very Thin Plastic Quad Flat Pack (PV) 5x5x0.9 mm Land Pattern.....	607
28-Lead Plastic Quad Flat No Lead Package (MQ) 5x5x0.9 mm Body .....	608
28-Lead Plastic Quad Flat No Lead Package (MQ) 5x5x0.9 mm Body Land Pattern.....	610
28-Lead Plastic Quad Flat No Lead Package (MQY) 5x5x0.9 mm Body .....	611
28-Lead Plastic Quad Flat No Lead Package (MQY) 5x5x0.9 mm Body Land Pattern .....	613
28-Lead Plastic Quad Flat (5N) 6x6x1.0 mm with 4.10x4.10 Exposed Pad Wettable Flanks Stepped.....	614
28-Lead Plastic Quad Flat (5N) 6x6x1.0 mm with 4.10x4.10 Exposed Pad Wettable Flanks Stepped Land Pattern .....	616
28-Lead Very Thin Quad Flat (4N) 6x6x1.0 mm with 3.7x3.7 Exposed Pad Wettable Flanks .....	617
28-Lead Very Thin Quad Flat (4N) 6x6x1.0 mm with 3.7x3.7 Exposed Pad Wettable Flanks Land Pattern.....	619
28-Lead Very Thin Quad Flat (9PX) 5x5 mm with Stepped Wettable Flanks 3.25x3.25 mm Exposed Pad.....	620
28-Lead Very Thin Quad Flat (9PX) 5x5 mm with Stepped Wettable Flanks 3.25x3.25 mm Exposed Pad Land Pattern .....	622
32-Lead Very Thin Plastic Quad Flat (RN) 5x5 mm Body with 3.3x3.3 mm Exposed Pad Punch .....	623
32-Lead Very Thin Plastic Quad Flat (RN) 5x5 mm Body with 3.3x3.3 mm Exposed Pad Punch Land Pattern.....	625
32-Lead Very Thin Quad Flat (MQ) 5x5x0.9 SMSC Legacy SQFN.....	626

---



---

## Package Index

---



---

32-Lead Very Thin Quad Flat (MQ) 5x5x0.9 SMSC Legacy SQFN Land Pattern .....	628
32-Lead Very Thin Quad Flat (S8) 5x5x0.9 mm with 3.7x3.7 mm Exposed Pad .....	629
32-Lead Very Thin Quad Flat (S8) 5x5x0.9 mm with 3.7x3.7 mm Exposed Pad Land Pattern .....	631
32-Lead Very Thin Plastic Quad Flat (P5A) 5x5x0.9 mm with 3.5x3.5 Exposed Pad .....	632
32-Lead Very Thin Plastic Quad Flat (P5A) 5x5x0.9 mm with 3.5x3.5 Exposed Pad Land Pattern .....	634
32-Lead Very Thin Plastic Quad Flat (PHA) 6x6 mm Wettable Flanks Multiple Exposed Pads .....	635
32-Lead Very Thin Plastic Quad Flat (PHA) 6x6 mm Wettable Flanks Multiple Exposed Pads Land Pattern .....	637
36-Terminal Very Thin Plastic Quad Flatpack (M2) 6x6x0.9 mm .....	638
36-Terminal Very Thin Plastic Quad Flatpack (M2) 6x6x0.9 mm Land Pattern .....	640
36-Terminal Very Thin Plastic Quad Flatpack (AEN) 6x6x0.9 mm .....	641
36-Terminal Very Thin Plastic Quad Flatpack (AEN) 6x6x0.9 mm Land Pattern .....	643
40-Lead Very Thin Quad Flat (NPA) 5x6.5 mm with Dimpled Wettable Flanks .....	644
40-Lead Very Thin Quad Flat (NPA) 5x6.5 mm with Dimpled Wettable Flanks Land Pattern .....	646
40-Lead Very Thin Quad Flat (NHX) 5x5 mm with 3.7x3.7 mm Exposed Pad and Wettable Flanks .....	647
40-Lead Very Thin Quad Flat (NHX) 5x5 mm with 3.7x3.7 mm Exposed Pad and Wettable Flanks Land Pattern .....	649
40-Lead Very Thin Quad Flat (UW) 6x6 mm Saw Singulated ISSC Legacy .....	650
40-Lead Very Thin Quad Flat (UW) 6x6 mm Saw Singulated ISSC Legacy Land Pattern .....	652
40-Lead Very Thin Quad Flat (VM) 6x6 mm Body with 4.62x4.62 Exposed Pad ISSC Legacy .....	653
40-Lead Very Thin Quad Flat (VM) 6x6 mm Body with 4.62x4.62 Exposed Pad ISSC Legacy Land Pattern .....	655
40-Lead Very Thin Plastic Quad Flat (PQA) 6x6 mm with 4.1x4.1 Exposed Pad .....	656
40-Lead Very Thin Plastic Quad Flat (PQA) 6x6 mm with 4.1x4.1 Exposed Pad Land Pattern .....	658
44-Lead Very Thin Quad Flat (PGA) 7x7x0.9 mm with 5.1x5.1 Exposed Pad .....	659
44-Lead Very Thin Quad Flat (PGA) 7x7x0.9 mm with 5.1x5.1 Exposed Pad Land Pattern .....	661
44-Lead Very Thin Quad Flat No Lead (3N) 8x8x1.0 Stepped .....	662
44-Lead Very Thin Quad Flat No Lead (3N) 8x8x1.0 Stepped Land Pattern .....	664
44-Lead Plastic Quad Flat No Lead (ML) 8x8 mm Body .....	665
44-Lead Plastic Quad Flat No Lead (ML) 8x8 mm Body Land Pattern .....	667
48-Lead Very Thin Quad Flat (UV) 5x6.5 mm Saw Singulated ISSC Legacy .....	668
48-Lead Very Thin Quad Flat (UV) 5x6.5 mm Saw Singulated ISSC Legacy Land Pattern .....	670
48-Lead Very Thin Quad Flat (VN) 6x6 mm Body Saw Singulated ISSC Legacy .....	671
48-Lead Very Thin Quad Flat (VN) 6x6 mm Body Saw Singulated ISSC Legacy Land Pattern .....	673
48-Lead Very Thin Quad Flat (VSX) 6x6 mm with 4.3x4.3 mm Exposed Pad .....	674
48-Lead Very Thin Quad Flat (VSX) 6x6 mm with 4.3x4.3 mm Exposed Pad Land Pattern .....	676
48-Lead Very Thin Quad Flat (UY) 7x7 mm Saw Singulated ISSC Legacy .....	677
48-Lead Very Thin Quad Flat (UY) 7x7 mm Saw Singulated ISSC Legacy Land Pattern .....	679
48-Lead Very Thin Quad Flat (VT) 7x7 mm Body Saw Singulated ISSC Legacy .....	680
48-Lead Very Thin Quad Flat (VT) 7x7 mm Body Saw Singulated ISSC Legacy Land Pattern .....	682
48-Lead Very Thin Quad Flat (ML) 7x7x1 mm with 4.1x4.1 Exposed Pad .....	683
48-Lead Very Thin Quad Flat (ML) 7x7x1 mm with 4.1x4.1 Exposed Pad Land Pattern .....	685
48-Lead Very Thin Quad Flat (Y3X) 7x7x1 mm with 4.1x4.1 Exposed Pad .....	686
48-Lead Very Thin Quad Flat (Y3X) 7x7x1 mm with 4.1x4.1 Exposed Pad Land Pattern .....	688



---



---

## Package Index

---



---

48-Lead Very Thin Quad Flat (ML) 7x7x1 mm with 5.3x5.3 Exposed Pad.....	689
48-Lead Very Thin Quad Flat (ML) 7x7x1 mm with 5.3x5.3 Exposed Pad Land Pattern .....	691
48-Lead Very Thin Quad Flat (Y9X) 7x7x1 mm with 5.3x5.3 Exposed Pad .....	692
48-Lead Very Thin Quad Flat (Y9X) 7x7x1 mm with 5.3x5.3 Exposed Pad Land Pattern .....	694
48-Lead Plastic Quad Flat No Lead Package (RS) 7x7 mm Body Exposed Pad Punch Singulated (AIS HZH).....	695
48-Lead Plastic Quad Flat No Lead Package (RS) 7x7 mm Body Exposed Pad Punch Singulated (AIS HZH) Land Pattern .....	697
48-Lead Very Thin Plastic Quad Flat (VQ) 7x7 mm Body with 5.3 Exposed Pad Punch .....	698
48-Lead Very Thin Plastic Quad Flat (VQ) 7x7 mm Body with 5.3 Exposed Pad Punch Land Pattern.....	700
52-Lead Very Thin Quad Flat (8HX) 8x8 mm with 6.6x6.6 mm Exposed Pad.....	701
52-Lead Very Thin Quad Flat (8HX) 8x8 mm with 6.6x6.6 mm Exposed Pad Land Pattern .....	703
56-Lead Very Thin Plastic Quad Flat (VU) 7x7 mm Body ISSC Legacy .....	704
56-Lead Very Thin Plastic Quad Flat (VU) 7x7 mm Body ISSC Legacy Land Pattern.....	706
56-Lead Very Thin Quad Flat (2G) 7x7 mm Body .....	707
56-Lead Very Thin Quad Flat (2G) 7x7 mm Body Land Pattern.....	709
56-Lead Very Thin Quad Flat (UZ) 7x7 mm Body Saw Singulated ISSC Legacy .....	710
56-Lead Very Thin Quad Flat (UZ) 7x7 mm Body Saw Singulated ISSC Legacy Land Pattern.....	712
56-Lead Very Thin Quad Flat (VW) 8x8 mm Saw Singulated ISSC Legacy .....	713
56-Lead Very Thin Quad Flat (VW) 8x8 mm Saw Singulated ISSC Legacy Land Pattern.....	715
56-Lead Very Thin Quad Flat (P6) 8x8 mm with 5.2x5.2 mm Exposed Pad Punch.....	716
56-Lead Very Thin Quad Flat (P6) 8x8 mm with 5.2x5.2 mm Exposed Pad Punch Land Pattern .....	718
56-Lead Very Thin Quad Flat (RT) 8x8 mm with 5.9x5.9 mm Exposed Pad Punch.....	719
56-Lead Very Thin Quad Flat (RT) 8x8 mm with 5.9x5.9 mm Exposed Pad Punch Land Pattern .....	721
64-Lead Very Thin Quad Flat (3S) 9x9 mm with 0.95mm Package Height.....	722
64-Lead Very Thin Quad Flat (3S) 9x9 mm with 0.95mm Package Height Land Pattern .....	724
64-Lead Very Thin Quad Flat (9JX) 9x9 mm with 6x6 mm Exposed Pad .....	725
64-Lead Very Thin Quad Flat (9JX) 9x9 mm with 6x6 mm Exposed Pad Land Pattern.....	727
64-Lead Very Thin Quad Flat (RG) 9x9 mm Punch Singulated.....	728
64-Lead Very Thin Quad Flat (RG) 9x9 mm with 7.3x7.3 Exposed Pad Punch Singulated continued .....	729
64-Lead Very Thin Quad Flat (RG) 9x9 mm with 6x6 Exposed Pad Punch Singulated continued .....	730
64-Lead Very Thin Quad Flat (RG) 9x9 mm with 4.7x4.7 Exposed Pad Punch Singulated continued .....	731
64-Lead Very Thin Plastic Quad Flat (MR) 9x9x0.9 mm with 7.15x7.15 Exposed Pad.....	732
64-Lead Very Thin Plastic Quad Flat (MR) 9x9x0.9 mm with 7.15x7.15 Exposed Pad Land Pattern.....	734
64-Lead Very Thin Plastic Quad Flat (R4X) 9x9x0.9 mm with 7.15x7.15 Exposed Pad .....	735
64-Lead Very Thin Plastic Quad Flat (R4X) 9x9x0.9 mm with 7.15x7.15 Exposed Pad Land Pattern.....	737
68-Lead Very Thin Quad Flat (VY) 8x8 mm with 6.2x6.2 Exposed Pad Saw Singulated ISSC Legacy.....	738
68-Lead Very Thin Quad Flat (VY) 8x8 mm with 6.2x6.2 Exposed Pad Saw Singulated ISSC Legacy Land Pattern .....	740
72-L Plastic Quad Flat (NQ) 10x10x1.0 Body .....	741
72-L Plastic Quad Flat (NQ) 10x10x1.0 Body Land Pattern.....	743
72-Lead Plastic Quad Flat (6E) 10x10x0.9 mm with 6x6 Exposed Pad Punch Singulated Dimpled Terminals .....	744
72-Lead Plastic Quad Flat (6E) 10x10x0.9 mm with 6x6 Exposed Pad Punch Singulated Dimpled Terminals Land Pattern.....	746
76-Lead Very Thin Quad Flat (QBA) 9x9 mm with 5x5 mm Exposed Pad.....	747

---



---

## Package Index

---



---

76-Lead Very Thin Quad Flat (QBA) 9x9 mm with 5x5 mm Exposed Pad Land Pattern .....	749
88-Lead Very Thin Quad Flat (PJ) 12x12 mm Body .....	750
88-Lead Very Thin Quad Flat (PJ) 12x12 mm Body Land Pattern .....	752
88-Lead Very Thin Plastic Quad Flat, No Lead Package (KB) 12x12x0.9 mm Punch Singulated Wettable Flanks 6x6 Exposed Pad .....	753
88-Lead Very Thin Plastic Quad Flat, No Lead Package (KB) 12x12x0.9 mm Punch Singulated Wettable Flanks 6x6 Exposed Pad Land Pattern .....	755
100-Lead Very Thin Quad Flat (KD) 12x12 mm Body .....	756
100-Lead Very Thin Quad Flat (KD) 12x12 mm Body Land Pattern .....	758
132-Lead Very Thin Plastic Quad Flat, No Lead Package (NX) 10x10x0.9 mm Body .....	759
132-Lead Very Thin Plastic Quad Flat, No Lead Package (NX) 10x10x0.9 mm Body Land Pattern .....	761

### WQFN

16-Lead Very Very Thin Quad Flat (NGA) 3x3 mm Body with 1.5x1.5 Exposed Pad .....	764
16-Lead Very Very Thin Quad Flat (NGA) 3x3 mm Body with 1.5x1.5 Exposed Pad Land Pattern .....	766

### XQFN

16-Lead Extremely Thin Quad Flat No Lead Package (NL) 3x3x0.5 mm Body .....	768
---	-----

### X2QFN

10-Lead Super-Thin Plastic Quad Flat No Lead Package (9X) 1.5x1.5 .....	772
10-Lead Super-Thin Plastic Quad Flat No Lead Package (9X) 1.5x1.5 Land Pattern .....	774
16-Lead Super Thin Quad Flat No Lead (NT) 2.5x2.5 mm SST Legacy .....	775
16-Lead Super Thin Quad Flat No Lead (NT) 2.5x2.5 mm SST Legacy Land Pattern .....	777

### WTLA

20-Lead Thermal Leadless Array Package (TL) 3x3x0.7 Exposed Pad .....	780
---	-----

### VTLA

36-Lead Thermal Leadless Array Package (TL) 5x5x0.9 Exposed Pad .....	784
36-Lead Thermal Leadless Array Package (TL) 5x5x0.9 Body Exposed Pad Land Pattern .....	786
44-Terminal Very Thin Leadless Array (TL) 6x6x0.9 mm .....	787
44-Terminal Very Thin Leadless Array (TL) 6x6x0.9 mm Body Land Pattern .....	789
124-Lead Very Thin Leadless Array (TL) 9x9x0.9 .....	790
124-Very Thin Leadless Array Package (TL) 9x9x0.9 mm Body Land Pattern .....	792

### MSOP

8-Lead Plastic Micro Small Outline Package (MS) .....	794
8-Lead Plastic Micro Small Outline Package (MS) Land Pattern .....	796
8-Lead Plastic Micro Small Outline Package (UA) .....	797
8-Lead Plastic Micro Small Outline Package (UA) Land Pattern .....	799
10-L Plastic Micro Small Outline Package (MS) .....	800
10-L Plastic Micro Small Outline Package (MS) Land Pattern .....	802
10-Lead Plastic Micro Small Outline Package (UN) .....	803
10-Lead Plastic Micro Small Outline Package (UN) Land Pattern .....	805



---



---

## Package Index

---



---

### QSOP

16-Lead Plastic Shrink Small Outline Narrow Body (QR) .150 Body .....	808
16-Lead Plastic Shrink Small Outline Narrow Body (QR) .150 Body Land Pattern.....	810
24-Lead Plastic Shrink Small Outline Narrow Body (QR) .150 Body .....	811
24-Lead Plastic Shrink Small Outline Narrow Body (QR) .150 Body Land Pattern.....	813

### SSOP

20-Lead Plastic Shrink Small Outline (SS) 5.30 .....	816
20-Lead Plastic Shrink Small Outline (SS) 5.30 Land Pattern .....	817
24-Lead Plastic Shrink Small Outline (SS) 5.30 .....	818
24-Lead Plastic Shrink Small Outline (SS) 5.30 Land Pattern .....	819
28-Lead Plastic Shrink Small Outline (SS) 5.30 .....	820
28-Lead Plastic Shrink Small Outline (SS) 5.30 Land Pattern .....	821

### TSSOP

8-Lead Plastic Thin Shrink Small Outline (ST) 4.4 mm .....	824
8-Lead Plastic Thin Shrink Small Outline (ST) 4.4 mm Land Pattern.....	825
14-Lead Plastic Thin Shrink Small Outline (ST) 4.4 .....	826
14-Lead Plastic Thin Shrink Small Outline (ST) 4.4 mm Land Pattern.....	828
16-Lead Plastic Thin Shrink Small Outline (ST) 4.4 .....	829
16-Lead Plastic Thin Shrink Small Outline (ST) 4.4 Land Pattern.....	831
20-Lead Plastic Thin Shrink Small Outline (ST) 4.4 mm Body .....	832
20-Lead Plastic Thin Shrink Small Outline (ST) 4.4 mm Land Pattern.....	834
38-Lead Thin Shrink Small Outline Package (SBX) 4.4 mm with 4.6x3.2 Exposed Pad.....	835
38-Lead Thin Shrink Small Outline Package (SBX) 4.4 mm with 4.6x3.2 Exposed Pad Land Pattern .....	837

### TSOP

28-Lead Plastic Thin Small Outline (TS) 8x20.....	840
48-Lead Thin Small Outline Package (TV) 12x20 .....	841

### VSOP

28-Lead Plastic Very Small Outline (VS) 8x13.4 .....	844
--	-----

### LQFP

32-Lead Plastic Low-Profile Quad Flatpack (PL) 7x7x14 .....	846
64-Lead Low Profile Plastic Quad Flatpack (PL) 10x10 mm .....	847
64-Lead Low Profile Plastic Quad Flatpack (PL) 10x10 mm Land Pattern .....	849
100-Lead Low Profile Quad Flatpack (PL) 14x14x1 mm Body.....	850
100-Lead Low Profile Quad Flatpack (PL) 14x14x1 mm Body Land Pattern.....	852
128-Lead Low Profile Plastic Quad Flat Pack(PT) 14x14x1.4mm.....	853
144-Lead Plastic Low Profile Quad Flatpack (PL) 20x20x140 .....	855
144-Lead Plastic Low Profile Quad Flatpack (PL) 20x20x1.40 Body Land Pattern .....	857

---



---

## Package Index

---



---

160-Lead Low Profile Quad Flatpack (6G) 24x24 mm with 2.00 mm Footprint.....	858
160-Lead Low Profile Quad Flatpack (6G) 24x24 mm with 2.00 mm Footprint Land Pattern .....	860
176-Lead Low Profile Quad Flat (2J) 20x20x1.4 mm Body with 7x7 Exposed Pad .....	861
176-Lead Low Profile Quad Flat (2J) 20x20x1.4 mm Body with 7x7 Exposed Pad Land Pattern .....	863

### MQFP

44-Lead Plastic Metric Quad Flatpack (KW) 10x10x2.....	866
44-Lead Plastic Metric Quad Flatpack (KW) 10x10x2 Land Pattern .....	867
44-Lead Plastic Metric Quad Flatpack (PQ) 10x10x2 .....	868
44-Lead Plastic Metric Quad Flatpack (PQ) 10x10x2 Land Pattern.....	869
64-Lead Plastic Metric Quad Flatpack (BU) 14x14x2.7.....	870
64-Lead Plastic Metric Quad Flatpack (BU) 14x14x2.7 Land Pattern.....	871
100-Lead Plastic Metric Quad Flatpack (PQ) 14x20 mm 3.90 mm Footprint.....	872
256-Lead Plastic Metric Quad Flatpack (PQ) 28x28x3.40 mm Body .....	874

### TQFP

32-Lead Plastic Thin Quad Flatpack (PT) 7x7x1.....	878
32-Lead Plastic Thin Quad Flatpack (PT) 7x7x1 Body Land Pattern .....	879
44-Lead Plastic Thin Quad Flatpack (PT) 10x10x1.0.....	880
44-Lead Plastic Thin Quad Flatpack (PT) 10X10X1 mm Body 2.00 mm Footprint .....	882
44-Lead Plastic Quad Flatpack (MW) 10x10x1.0 mm 4.5x4.5 mm Exposed Pad.....	883
48-Lead Thin Quad Flatpack (PT) 7x7x1 mm Body .....	885
48-Lead Thin Quad Flatpack (PT) 7x7x1 mm Body Land Pattern.....	887
48-L Thin Quad Flatpack (PT) 7x7x1.0 Body .....	888
48-L Thin Quad Flatpack (PT) 7x7x1.0 Body Land Pattern.....	890
48-L Thin Quad Flatpack (Y8) 7x7x1.0 Body.....	891
48-L Thin Quad Flatpack (Y8) 7x7x1.0 Body Land Pattern.....	893
64-Lead Plastic Thin Quad Flatpack (PF) 14x14x1.....	894
64-Lead Plastic Thin Quad Flatpack (PF) 14x14x1 Land Pattern .....	895
64-Lead Plastic Thin Quad Flatpack (PT) 10x10x1 mm Body.....	896
64-Lead Plastic Thin Quad Flatpack (PT) 10x10x1 mm Body Land Pattern .....	898
64-Lead Thin Quad Flatpack (JVX) 10x10x1 mm Body 2.00 Footprint 5.7x5.7 mm Exposed Pad.....	899
64-Lead Thin Quad Flatpack (JVX) 10x10x1 mm Body 2.00 Footprint 5.7x5.7 mm Exposed Pad Land Pattern .....	901
64-Lead Plastic Thin Quad Flatpack (PT) 10x10x1 mm Body with 6x6 Exposed Pad .....	902
64-Lead Plastic Thin Quad Flatpack (PT) 10x10x1 mm Body with 6x6 Exposed Pad Land Pattern .....	904
80-Lead Plastic Thin Quad Flatpack (PF) 14x14x1.....	905
80-Lead Plastic Thin Quad Flatpack (PF) 14x14 Body Land Pattern.....	906
80-Lead Plastic Thin Quad Flatpack (PT) 12x12x1.....	907
80-Lead Plastic Thin Quad Flatpack (PT) 12x12x1 Body Land Pattern.....	908
100-Lead Plastic Thin Quad Flatpack (PF) 14x14x1 .....	909
100-Lead Plastic Thin Quad Flatpack (PF) 14x14 Body Land Pattern .....	910
100-Lead Plastic Thin Quad Flatpack (PT) 12x12x1 .....	911

---



---

## Package Index

---



---

100-Lead Plastic Thin Quad Flatpack (PT) 12x12x1 Body Land Pattern.....	912
128-Lead Plastic Quad Flat No Lead (Z7) 14x14x1.0 mm with 5.0x5.0 mm Exposed Pad.....	913
128-Lead Thin Quad Flatpack (6XX) 10x10x1.0 mm Body with 10x10 mm Exposed Pad .....	915
128-Lead Thin Quad Flatpack (6XX) 10x10x1.0 mm Body with 10x10 mm Exposed Pad Land Pattern.....	917
144-Lead Plastic Thin Quad Flat Pack (PH) 16x16 Body.....	918
144-Lead Plastic Thin Quad Flat Pack (PH) 16x16 Body Land Pattern.....	920

### **(WL)CSP**

---

4-Lead Chip Scale Package (CS) square.....	922
4-Lead Chip Scale Package (CS) Land Pattern, Square .....	924
4-Lead Chip Scale (CS) rectangle.....	925
4-Lead Chip Scale (CS) Land Pattern, Rectangle.....	927
5-Lead Chip Scale Package (CS).....	928
5-Lead Chip Scale Package (CS) Ball Pattern 2x1x2 Land Pattern.....	930
8-Ball Extremely Thin Fine Pitch Wafer Level Chip Scale Package (CS).....	931
8-Ball Extremely Thin Fine Pitch Wafer Level Chip Scale Package (CS) Land Pattern.....	933
9-Bump Wafer Level Chip Scale Package (CS).....	934
9-Bump Wafer Level Chip Scale Package (CS) Land Pattern .....	936
32-Lead Chip Scale Package (CS).....	937
32-Ball Wafer Level Chip Scale Package (CS) Land Pattern.....	939

### **WLCSP**

---

8-Bump Extremely Thin Fine Pitch Wafer Level (CS).....	942
8-Bump Extremely Thin Fine Pitch Wafer Level (CS) Land Pattern.....	944
9-Bump Wafer Level Chip Scale Package (CS).....	945
9-Bump Wafer Level Chip Scale Package (CS) Land Pattern .....	947
14-Ball Wafer Level Chipscale Package (CS).....	948
14-Ball Wafer Level Chipscale Package (CS) Land Pattern .....	950

### **LLGA**

---

6-Lead Low Profile Land Grid Array (ANA) 5.0x3.2 mm Body.....	954
6-Lead Low Profile Land Grid Array (ANA) 5.0x3.2 mm Body Land Pattern.....	956
6-Lead Low Profile Land Grid Array (APA) 7x5 mm Body .....	957
6-Lead Low Profile Land Grid Array (APA) 7x5 mm Body Land Pattern .....	959

### **VLGA**

---

6-Lead Very Thin Land Grid Array (ALA) 3.2x2.5 mm Body.....	962
6-Lead Very Thin Land Grid Array (ALA) 3.2x2.5 mm Body Land Pattern .....	964

### **CABGA**

---

22-Ball Chip Array Ball Grid Array (JY) 5x7 mm Body.....	966
22-Ball Chip Array Ball Grid Array (JY) 5x7 mm Body Land Pattern .....	968

---



---

## Package Index

---



---

### TBGA

24-Ball Thin Profile Ball Grid Array (TD) 6x8 mm Body.....	970
--	-----

### LFBGA

169-Ball Low Profile Ball Grid Array (6JX) 11x11 mm Body.....	974
169-Ball Low Profile Ball Grid Array (6JX) 11x11 mm Body Land Pattern.....	976
169-Ball Low Profile Fine Pitch Ball Grid Array (HF) 11x11x1.4 mm Body.....	977
169-Ball Low Profile Fine Pitch Ball Grid Array (HF) 11x11x1.4 mm Body Land Pattern.....	979
196-Ball Low Profile Fine Pitch Ball Grid Array (RG) 12x12x1.4 mm.....	980
196-Ball Low Profile Fine Pitch Ball Grid Array (RG) 12x12x1.4 mm Land Pattern.....	982
256-Ball Low Profile Fine Pitch Ball Grid Array (3J) 14x14 mm Body.....	983
256-Ball Low Profile Fine Pitch Ball Grid Array (3J) 14x14 mm Body Land Pattern.....	985
288-Ball Low Profile Fine Pitch Ball Grid Array (4J) 15x15x1.4 mm Body.....	986
288-Ball Low Profile Fine Pitch Ball Grid Array (4J) 15x15x1.4 mm Body Land Pattern.....	988

### TFBGA

48-Ball Plastic Thin Profile Fine Pitch Ball Grid Array (CD) 6x8 mm Body.....	990
84-Ball Thin Fine Pitch Ball Grid Array (GQ) 6x6 mm Body.....	992
84-Ball Thin Fine Pitch Ball Grid Array (GQ) 6x6 mm Body Land Pattern.....	994
100-Ball Thin Fine Pitch Ball Grid Array (GJX) 7x7 mm.....	995
100-Ball Thin Fine Pitch Ball Grid Array (GJX) 7x7 mm Land Pattern.....	997
100-Ball Thin Fine Pitch Ball Grid Array (GJ) 7x7 mm Body.....	998
100-Ball Thin Fine Pitch Ball Grid Array (GJ) 7x7 mm Body Land Pattern.....	1000
121-Ball Thin Pitch Ball Grid Array (3XX) 8x8 mm SiP.....	1001
121-Ball Thin Pitch Ball Grid Array (3XX) 8x8 mm SiP Land Pattern.....	1003
121-Ball Thin Pitch Ball Grid Array (TE) 8x8 mm SiP.....	1004
121-Ball Thin Pitch Ball Grid Array (TE) 8x8 mm SiP Land Pattern.....	1006
121-Ball Plastic Thin Profile Fine Pitch Ball Grid Array (BG) 10x10x1.10 mm Body.....	1007
121-Lead Plastic Thin Profile Ball Grid Array (BG) 10x10x1.10 Land Pattern.....	1009
129-Ball Thin Fine Pitch Ball Grid Array (2H) 7x7 mm Body.....	1010
129-Ball Thin Fine Pitch Ball Grid Array (2H) 7x7 mm Body Land Pattern.....	1012
129-Ball Thin Fine Pitch Ball Grid Array (GW) 7x7 mm Body.....	1013
129-Ball Thin Fine Pitch Ball Grid Array (GW) 7x7 mm Body Land Pattern.....	1015
132-Ball Thin Fine Pitch Ball Grid Array (AHA) 12x12x1.2 mm.....	1016
132-Ball Thin Fine Pitch Ball Grid Array (AHA) 12x12x1.2 mm Land Pattern.....	1018
144-Ball Thin Fine Pitch Ball Grid Array (JWX) 7x7 mm Body.....	1019
144-Ball Thin Fine Pitch Ball Grid Array (JWX) 7x7 mm Body Land Pattern.....	1021
168-Ball Fine Pitch Ball Grid Array (AFA) 13x13x1.2 mm.....	1022
168-Ball Fine Pitch Ball Grid Array (AFA) 13x13x1.2 mm Land Pattern.....	1024
169-Ball Thin Fine Pitch Ball Grid Array (7G) 10x10x1.1 mm Body.....	1025
169-Ball Thin Fine Pitch Ball Grid Array (7G) 10x10x1.1 mm Body Land Pattern.....	1027
169-Ball Thin Fine Pitch Ball Grid Array (7G) 10x10x1.1 mm Body noncompliant.....	1028

---



---

## Package Index

---



---

169-Ball Thin Fine Pitch Ball Grid Array (7G) 10x10x1.1 mm Body Land Pattern noncompliant .....	1030
323-Ball Thin Fine Pitch Ball Grid Array (HX) 14x14x1.14 mm Body .....	1031

### UFBGA

25-Ball Ultra Thin Fine Pitch Ball Grid Array (FE) 3x3 mm Body.....	1034
25-Ball Ultra Thin Fine Pitch Ball Grid Array (FE) 3x3 mm Body Land Pattern .....	1036

### VFBGA

61-Ball Very Thin Pitch Ball Grid Array (5HX) 5x5x0.9 Body.....	1038
61-Ball Very Thin Pitch Ball Grid Array (5HX) 5x5x0.9 Body Land Pattern .....	1040
64-Ball Very Thin Fine Pitch Ball Grid Array (4G) 7x7x1.0 Body .....	1041
64-Ball Very Thin Fine Pitch Ball Grid Array (4G) 7x7x1.0 Body Land Pattern .....	1043
64-Ball Very Thin Fine Pitch Ball Grid Array (GA) 7x7x1.0 Body.....	1044
64-Ball Very Thin Fine Pitch Ball Grid Array (GA) 7x7x1.0 Body Land Pattern .....	1046
78-Ball Very Thin Fine Pitch Ball Grid Array (5G) 9x9x1.0 mm Body .....	1047
78-Ball Very Thin Fine Pitch Ball Grid Array (5G) 9x9x1.0 Land Pattern.....	1049
78-Ball Very Thin Fine Pitch Ball Grid Array (GA) 9x9x1.0 mm Body.....	1050
78-Ball Very Thin Fine Pitch Ball Grid Array (GA) 9x9x1.0 mm Body Land Pattern .....	1052

### WFBGA

64-Ball Very Very Thin Fine Pitch Ball Grid Array (7U) 6x6 mm.....	1054
64-Ball Very Very Thin Fine Pitch Ball Grid Array (7U) 6x6 mm Land Pattern .....	1056
84-Ball Very Very Thin Fine Pitch Ball Grid Array (SX) 7x7 mm.....	1057
84-Ball Very Very Thin Fine Pitch Ball Grid Array (SX) 7x7 mm Land Pattern .....	1059
100-Ball Very Very Thin Fine Pitch Ball Grid Array (SY) 8x8 mm.....	1060
100-Ball Very Very Thin Fine Pitch Ball Grid Array (SY) 8x8 mm Land Pattern .....	1062
144-Ball Very Very Thin Fine Pitch Ball Grid Array (SZ) 9x9x0.8 Body .....	1063
144-Ball Very Very Thin Fine Pitch Ball Grid Array (SZ) 9x9x0.8 Body Land Pattern .....	1065
169-Ball Very Very Thin Fine Pitch Ball Grid Array (TN) 11x11 mm .....	1066
169-Ball Very Very Thin Fine Pitch Ball Grid Array (TN) 11x11 mm Land Pattern.....	1068

### XFBGA

144-Ball Extremely Thin Fine Pitch Ball Grid Array (TZ) 7x7 mm Body .....	1068
144-Ball Extremely Thin Fine Pitch Ball Grid Array (TZ) 7x7 mm Body Land Pattern.....	1070

### VFLGA

4-Lead Very Thin Fine Pitch Land Grid Array (ARA) 1.6x1.2 mm .....	1072
4-Lead Very Thin Fine Pitch Land Grid Array (ARA) 1.6x1.2 mm Land Pattern.....	1074
4-Lead Very Thin Fine Pitch Land Grid Array (ASA) 2x1.6 mm.....	1075
4-Lead Very Thin Fine Pitch Land Grid Array (ASA) 2x1.6 mm Land Pattern .....	1077
4-Lead Very Thin Land Grid Array (AUA) 2.5x2 mm Body .....	1078
4-Lead Very Thin Land Grid Array (AUA) 2.5x2 mm Body Land Pattern.....	1080
6-Lead Very Thin Fine Pitch Land Grid Array (AVA) 1.6x1.2 mm .....	1081



---

---

## Package Index

---

---

6-Lead Very Thin Fine Pitch Land Grid Array (AVA) 1.6x1.2 mm Land Pattern.....	1083
6-Lead Very Thin Fine Pitch Land Grid Array (ATA) 2x1.6 mm .....	1084
6-Lead Very Thin Fine Pitch Land Grid Array (ATA) 2x1.6 mm Land Pattern.....	1086
6-Lead Very Thin Fine Pitch Land Grid Array (AWA) 2.5x2 mm.....	1087
6-Lead Very Thin Fine Pitch Land Grid Array (AWA) 2.5x2 mm Land Pattern .....	1089
56L Very Thin Fine Pitch Land Grid Array (4W) 7x7x0.9 mm Body with Exposed Pad.....	1090
56L Very Thin Fine Pitch Land Grid Array (4W) 7x7x0.9 mm Body with Exposed Pad Land Pattern .....	1092
68-Lead Very Thin Fine Pitch Land Grid Array (2W) 8x8x0.9 mm Body with Exposed Pads ISSC Legacy.....	1093
68-Lead Very Thin Fine Pitch Land Grid Array (2W) 8x8x0.9 mm Body with Exposed Pads ISSC Legacy Land Pattern .....	1095
68-Lead Very Thin Fine Pitch Land Grid Array (7W) 8x8x0.9 mm Body with Exposed Pads ISSC Legacy.....	1096
68-Lead Very Thin Fine Pitch Land Grid Array (7W) 8x8x0.9 mm Body with Exposed Pads ISSC Legacy Land Pattern .....	1098

---

---

**Package Outlines and Dimensions**

---

---

**SIDEBRAZE**

**Package Outlines and Dimensions**

**8-Lead Ceramic Side Brazed Dual In-Line with Window (JW) – .300" Body**

**Note:** For the most current package drawings, please see the Microchip Packaging Specification located at <http://www.microchip.com/packaging>

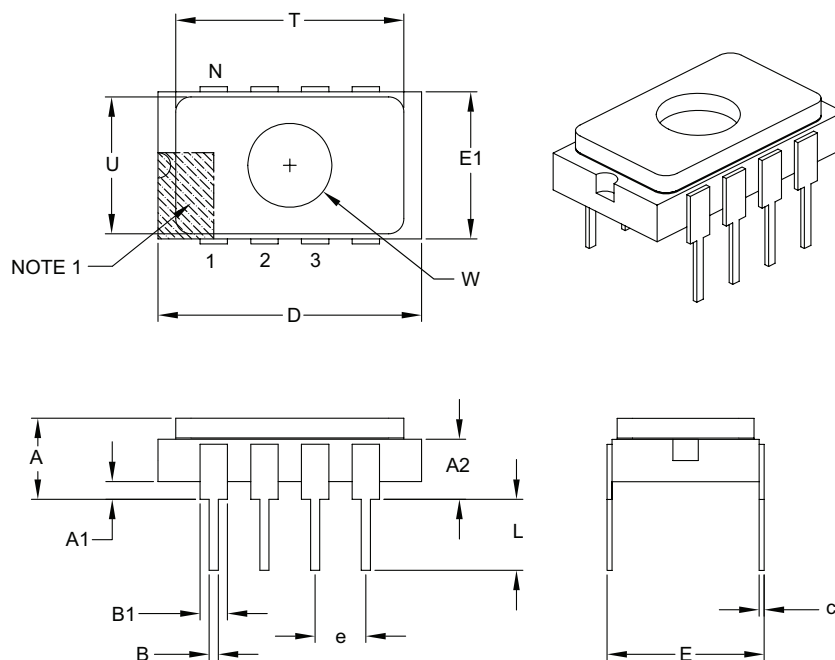

Dimension Limits	Units	INCHES		
		MIN	NOM	MAX
Number of Pins	N	8		
Pitch	e	.100 BSC		
Top to Seating Plane	A	.085	–	.200
Top of Body to Seating Plane	A2	.103	–	.143
Standoff	A1	.025	–	.070
Package Width	E1	.280	–	.310
Overall Length	D	.500	–	.540
Tip to Seating Plane	L	.125	–	.200
Lead Thickness	c	.008	–	.015
Upper Lead Width	B1	.045	–	.065
Lower Lead Width	B	.015	–	.022
Overall Row Spacing §	E	.300	–	.325
Window Diameter	W	.161	–	.171
Lid Length	T	.440	–	.460
Lid Width	U	.260	–	.280

**Notes:**

- Pin 1 visual index feature may vary, but must be located within the hatched area.
- § Significant Characteristic.
- Dimensions D and E1 do not include burrs and/or projections of package material. These particles shall not exceed .010" per side.
- Dimensioning and tolerancing per ASME Y14.5M.

BSC: Basic Dimension. Theoretically exact value shown without tolerances.



---



---

## Package Outlines and Dimensions

---



---

### 14-Lead Ceramic Side Brazed Dual In-Line with Window (JW) – .300" Body

**Note:** For the most current package drawings, please see the Microchip Packaging Specification located at <http://www.microchip.com/packaging>

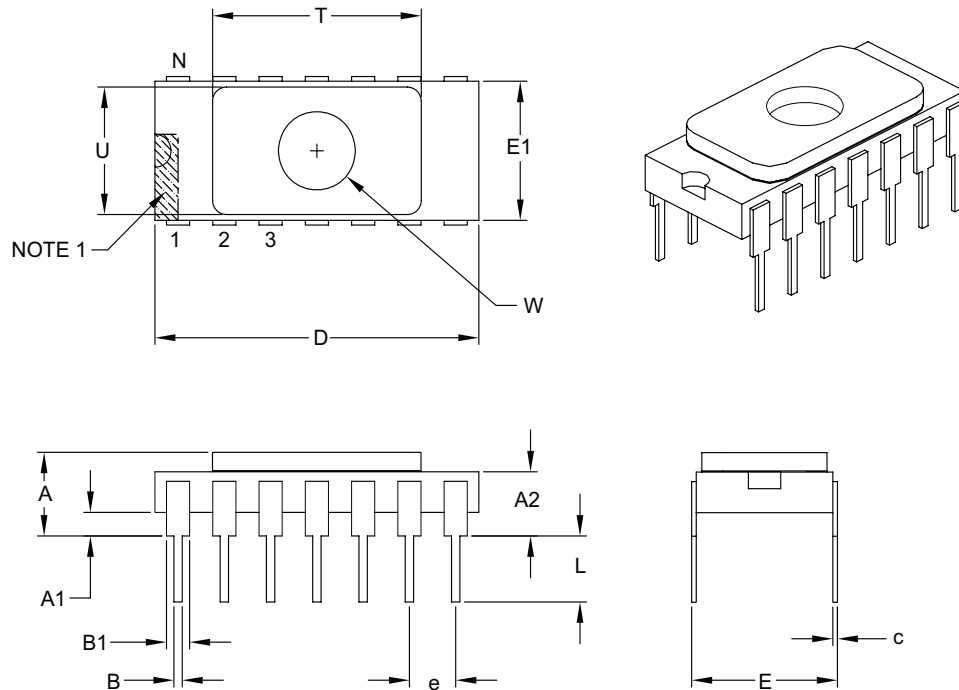

Dimension Limits	Units	INCHES		
		MIN	NOM	MAX
Number of Pins	N	14		
Pitch	e	.100 BSC		
Top to Seating Plane	A	.085	–	.200
Top of Body to Seating Plane	A2	.100	–	.140
Standoff	A1	.025	–	.070
Package Width	E1	.280	–	.310
Overall Length	D	.693	–	.770
Tip to Seating Plane	L	.125	–	.200
Lead Thickness	c	.008	–	.015
Upper Lead Width	B1	.045	–	.065
Lower Lead Width	B	.015	–	.022
Overall Row Spacing §	E	.300	–	.325
Window Diameter	W	.161	–	.171
Lid Length	T	.440	–	.460
Lid Width	U	.260	–	.280

**Notes:**

1. Pin 1 visual index feature may vary, but must be located within the hatched area.
2. § Significant Characteristic.
3. Dimensions D and E1 do not include burrs and/or projections of package material. These particles shall not exceed .010" per side.
4. Dimensioning and tolerancing per ASME Y14.5M.

BSC: Basic Dimension. Theoretically exact value shown without tolerances.

Microchip Technology Drawing C04-107B

## Package Outlines and Dimensions

### 28-Lead Ceramic Side Brazed Dual In-Line with Window (JW) – .300" Body

**Note:** For the most current package drawings, please see the Microchip Packaging Specification located at <http://www.microchip.com/packaging>

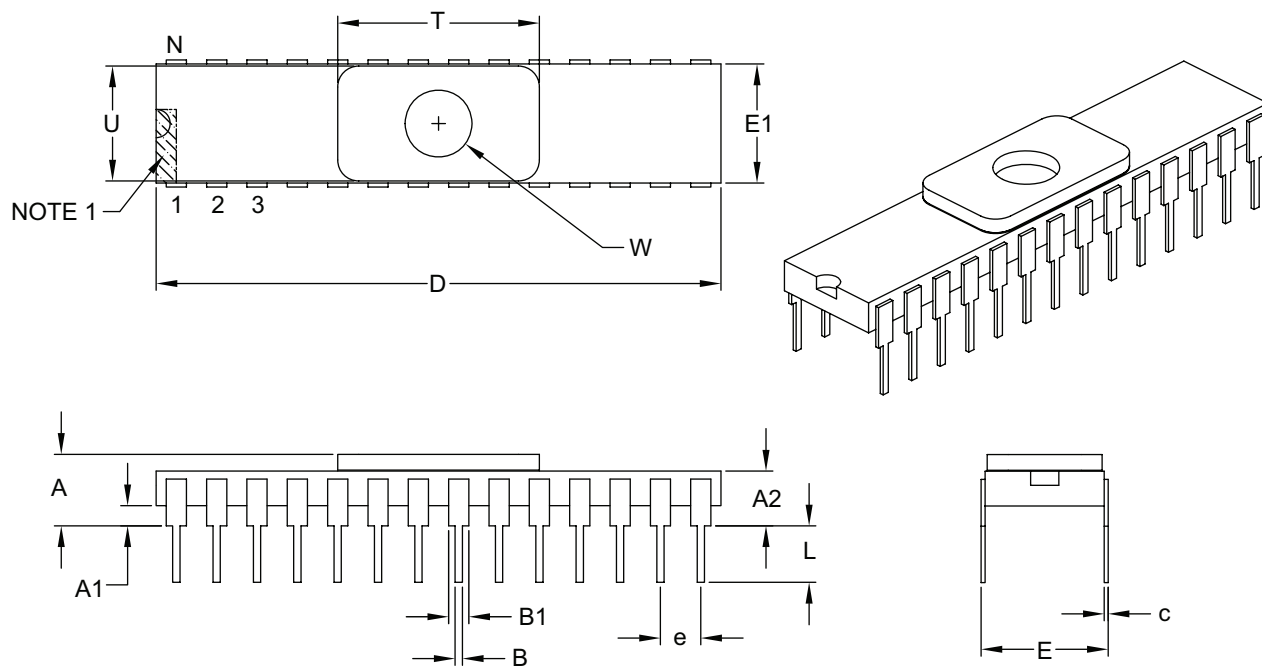

Dimension Limits	Units	INCHES		
		MIN	NOM	MAX
Number of Pins	N	28		
Pitch	e	.100 BSC		
Top to Seating Plane	A	.085	–	.200
Top of Body to Seating Plane	A2	.115	–	.155
Standoff	A1	.025	–	.070
Package Width	E1	.280	–	.310
Overall Length	D	1.380	–	1.420
Tip to Seating Plane	L	.125	–	.200
Lead Thickness	c	.008	–	.015
Upper Lead Width	B1	.045	–	.065
Lower Lead Width	B	.015	–	.022
Overall Row Spacing §	E	.300	–	.325
Window Diameter	W	.161	–	.171
Lid Length	T	.490	–	.510
Lid Width	U	.275	–	.295

**Notes:**

- Pin 1 visual index feature may vary, but must be located within the hatched area.
- § Significant Characteristic.
- Dimensions D and E1 do not include burrs and/or projections of package material. These particles shall not exceed .010" per side.
- Dimensioning and tolerancing per ASME Y14.5M.

BSC: Basic Dimension. Theoretically exact value shown without tolerances.

Microchip Technology Drawing C04-084B

---

---

**Package Outlines and Dimensions**

---

---

**CERDIP**

**Package Outlines and Dimensions**

**8-Lead Ceramic Dual In-Line (JA) ~ .300" Body [CERDIP]**

**Note:** For the most current package drawings, please see the Microchip Packaging Specification located at <http://www.microchip.com/packaging>

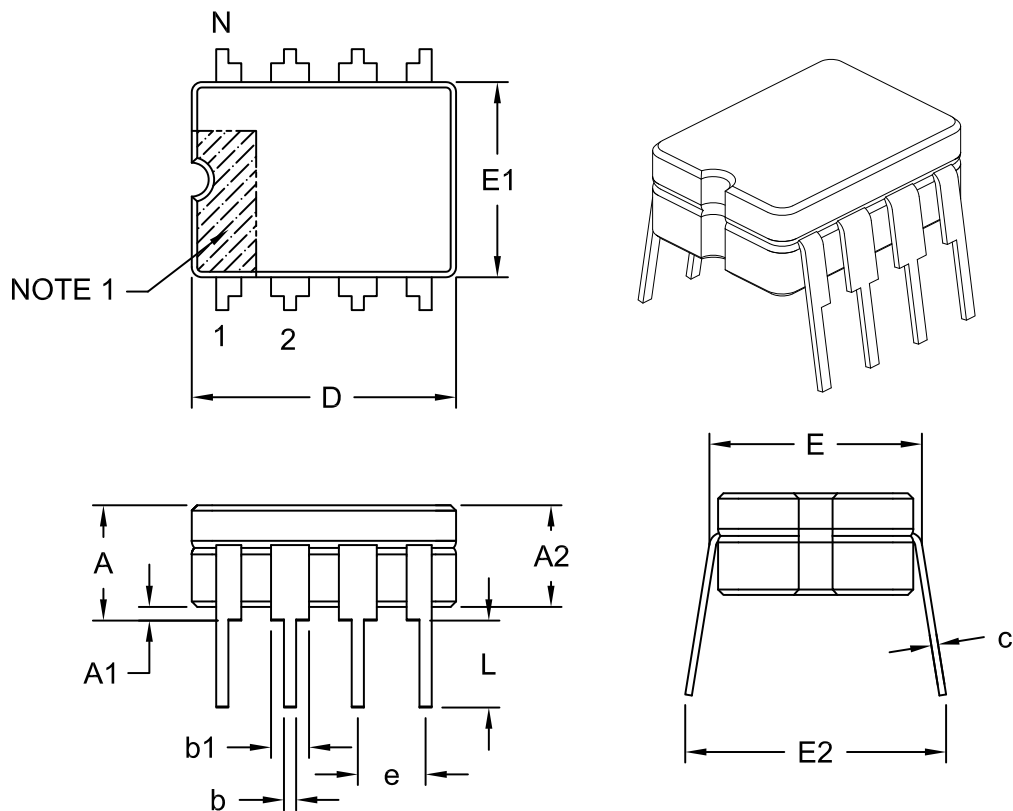

Dimension Limits	Units	INCHES		
		MIN	NOM	MAX
Number of Pins	N	8		
Pitch	e	.100 BSC		
Top to Seating Plane	A	-	-	.200
Base to Seating Plane §	A1	.015	-	-
Ceramic Package Height	A2	.140	-	.175
Shoulder to Shoulder Width	E	.290	-	.320
Ceramic Pkg. Width	E1	.230	.248	.300
Overall Length	D	.370	.380	.400
Tip to Seating Plane	L	.125	-	.200
Lead Thickness	c	.008	-	.015
Upper Lead Width	b1	.045	-	.065
Lower Lead Width	b	.015	-	.023
Overall Row Spacing	E2	.314	-	.410

**Notes:**

1. Pin 1 visual index feature may vary, but must be located within the hatched area.
2. § Significant Characteristic
3. Dimensioning and tolerancing per ASME Y14.5M  
BSC: Basic Dimension. Theoretically exact value shown without tolerances.

---



---

## Package Outlines and Dimensions

---



---

### 8-Lead Ceramic Dual In-Line with Window (JW) ~ .300" Body [CERDIP]

**Note:** For the most current package drawings, please see the Microchip Packaging Specification located at <http://www.microchip.com/packaging>

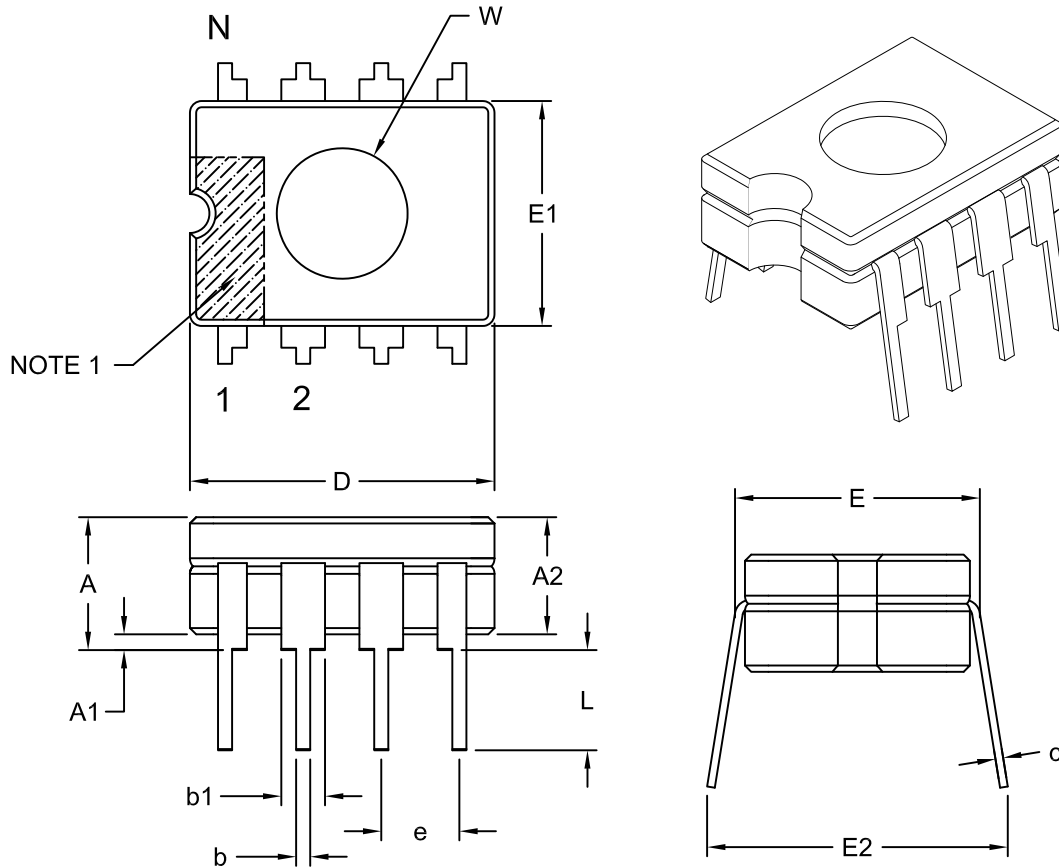

		Units	INCHES		
Dimension Limits		MIN	NOM	MAX	
Number of Pins	N	8			
Pitch	e	.100 BSC			
Top to Seating Plane	A	-	-	.200	
Base to Seating Plane §	A1	.015	-	-	
Ceramic Package Height	A2	.140	-	.175	
Shoulder to Shoulder Width	E	.290	-	.320	
Ceramic Pkg. Width	E1	.230	.248	.300	
Overall Length	D	.370	.380	.400	
Tip to Seating Plane	L	.125	-	.200	
Lead Thickness	c	.008	-	.015	
Upper Lead Width	b1	.045	-	.065	
Lower Lead Width	b	.015	-	.023	
Overall Row Spacing	E2	.314	-	.410	
Window Diameter	W	.267	.270	.273	

**Notes:**

1. Pin 1 visual index feature may vary, but must be located within the hatched area.
2. § Significant Characteristic
3. Dimensioning and tolerancing per ASME Y14.5M

BSC: Basic Dimension. Theoretically exact value shown without tolerances.

Microchip Technology Drawing No. C04-027C

**Package Outlines and Dimensions**

**14-Lead Ceramic Dual In-Line (JD) ~ .300" Body [CERDIP]**

**Note:** For the most current package drawings, please see the Microchip Packaging Specification located at <http://www.microchip.com/packaging>

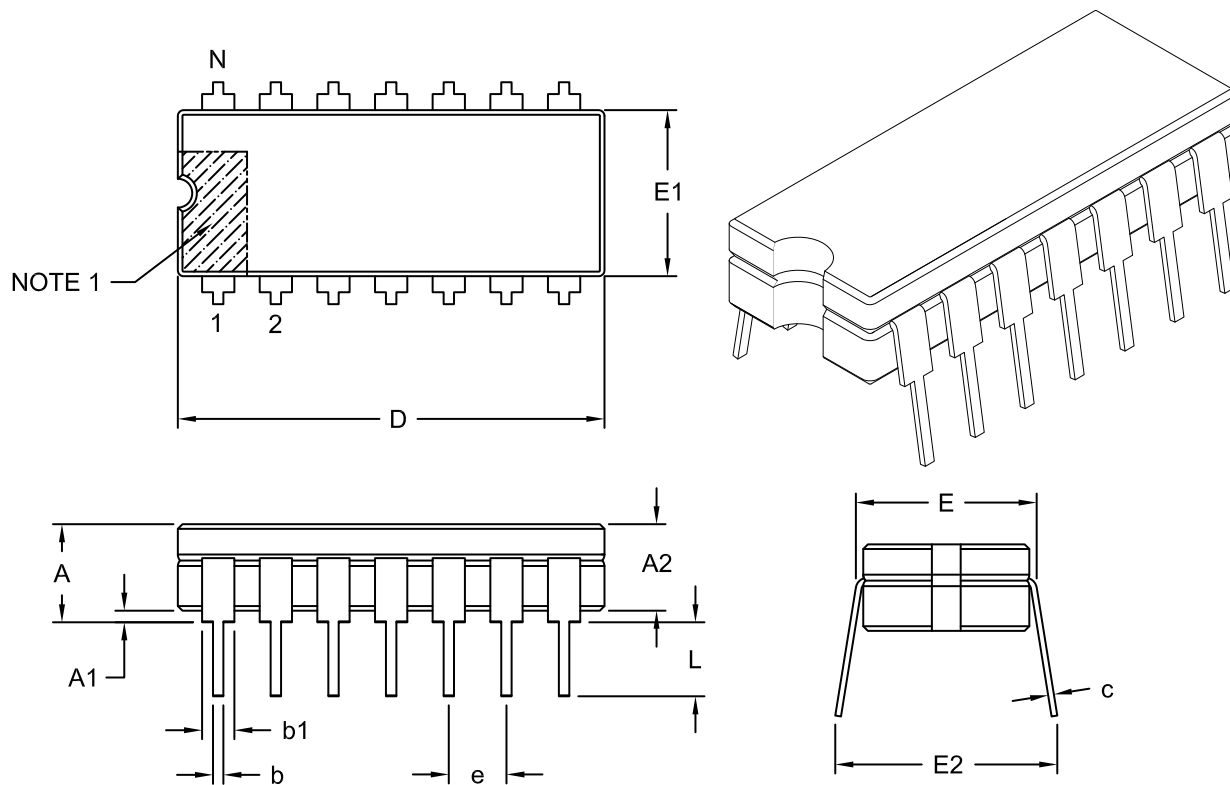

Dimension Limits	Units	INCHES		
		MIN	NOM	MAX
Number of Pins	N	14		
Pitch	e	.100 BSC		
Top to Seating Plane	A	-	-	.200
Base to Seating Plane §	A1	.015	-	-
Ceramic Package Height	A2	.140	-	.175
Shoulder-to-Shoulder Width	E	.290	-	.325
Ceramic Pkg. Width	E1	.230	.288	.300
Overall Length	D	.740	.760	.780
Tip to Seating Plane	L	.125	-	.200
Lead Thickness	c	.008	-	.015
Upper Lead Width	b1	.045	-	.065
Lower Lead Width	b	.015	-	.023
Overall Row Spacing	E2	.320	-	.410

**Notes:**

- Pin 1 visual index feature may vary, but must be located within the hatched area.
- § Significant Characteristic
- Dimensioning and tolerancing per ASME Y14.5M

BSC: Basic Dimension. Theoretically exact value shown without tolerances.

Microchip Technology Drawing No. C04-002C

---



---

## Package Outlines and Dimensions

---



---

### 14-Lead Ceramic Dual In-Line with Window (JW) ~ .300" Body [CERDIP]

**Note:** For the most current package drawings, please see the Microchip Packaging Specification located at <http://www.microchip.com/packaging>

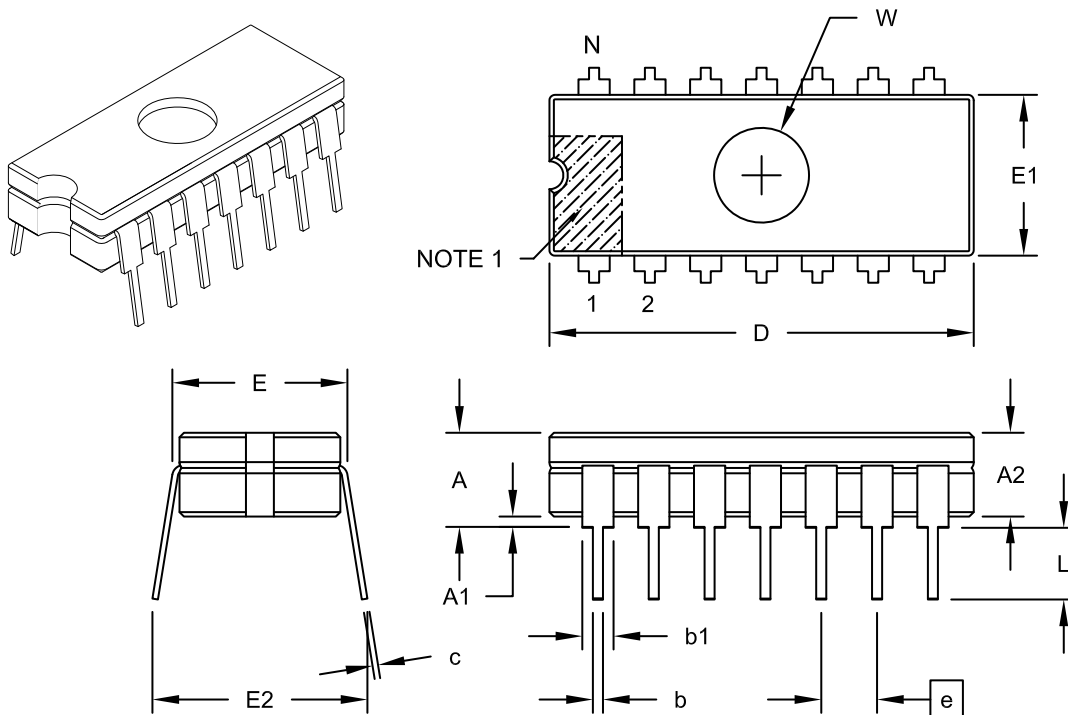

Dimension Limits	Units	INCHES		
		MIN	NOM	MAX
Number of Pins	N	14		
Pitch	e	.100 BSC		
Top to Seating Plane	A	-	-	.200
Base to Seating Plane §	A1	.015	-	-
Ceramic Package Height	A2	.140	-	.175
Shoulder to Shoulder Width	E	.290	-	.325
Ceramic Pkg. Width	E1	.230	.288	.300
Overall Length	D	.740	.760	.780
Window Diameter	W	.125	.170	.210
Tip to Seating Plane	L	.125	-	.200
Lead Thickness	c	.008	-	.015
Upper Lead Width	b1	.045	-	.065
Lower Lead Width	b	.015	-	.023
Overall Row Spacing	E2	.320	-	.410

**Notes:**

1. Pin 1 visual index feature may vary, but must be located within the hatched area.
2. § Significant Characteristic
3. Dimensioning and tolerancing per ASME Y14.5M.

BSC: Basic Dimension. Theoretically exact value shown without tolerances.

REF: Reference Dimension, usually without tolerance, for information purposes only.

Microchip Technology Drawing No. C04-099C

**Package Outlines and Dimensions**

**16-Lead Ceramic Dual In-Line (JE) ~ .300" Body [CERDIP]**

**Note:** For the most current package drawings, please see the Microchip Packaging Specification located at <http://www.microchip.com/packaging>

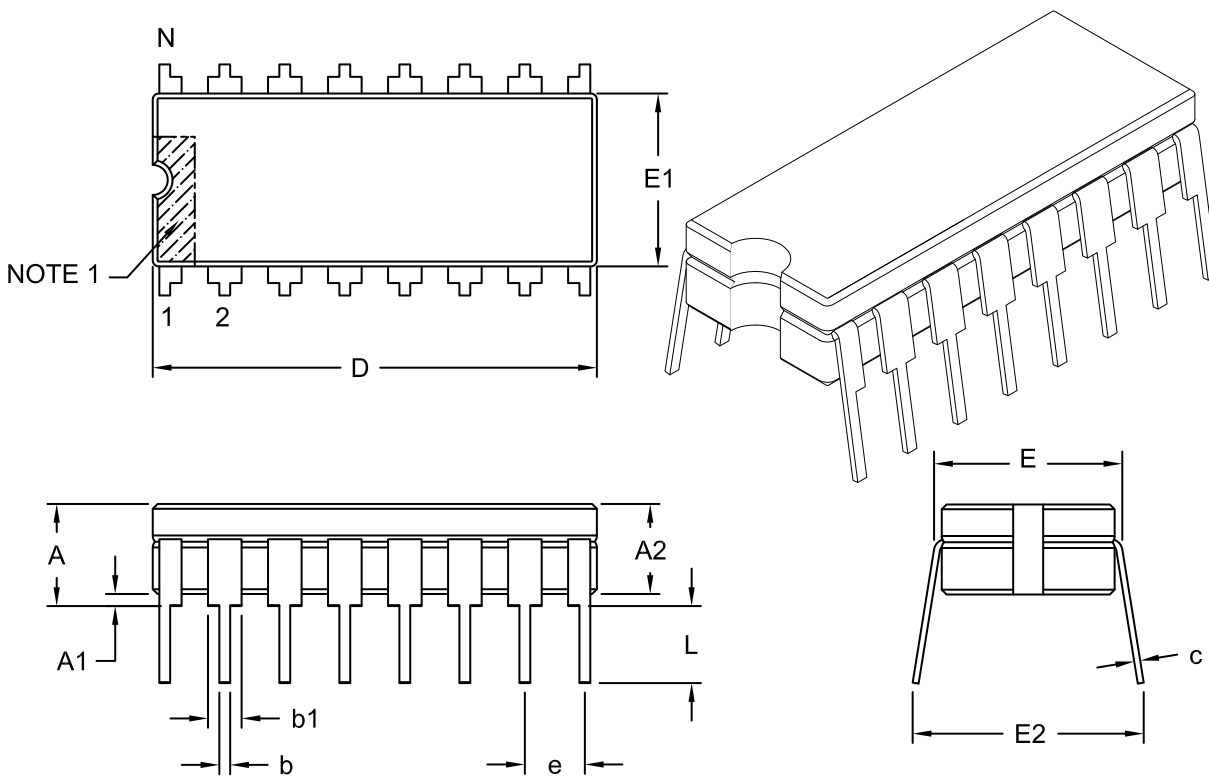

Dimension Limits	Units	INCHES		
		MIN	NOM	MAX
Number of Pins	N	16		
Pitch	e	.100 BSC		
Top to Seating Plane	A	-	-	.200
Base to Seating Plane §	A1	.015	-	-
Ceramic Package Height	A2	.140	-	.175
Shoulder to Shoulder Width	E	.290	-	.325
Ceramic Pkg. Width	E1	.245	.288	.300
Overall Length	D	.740	.760	.780
Tip to Seating Plane	L	.125	-	.200
Lead Thickness	c	.008	-	.015
Upper Lead Width	b1	.045	-	.065
Lower Lead Width	b	.015	-	.023
Overall Row Spacing	E2	.320	-	.410

**Notes:**

1. Pin 1 visual index feature may vary, but must be located within the hatched area.
2. § Significant Characteristic
3. Dimensioning and tolerancing per ASME Y14.5M

BSC: Basic Dimension. Theoretically exact value shown without tolerances.

Microchip Technology Drawing No. C04-003C



---



---

## Package Outlines and Dimensions

---



---

### 18-Lead Ceramic Dual In-Line with Window (JW) ~ .300" Body [CERDIP]

**Note:** For the most current package drawings, please see the Microchip Packaging Specification located at <http://www.microchip.com/packaging>

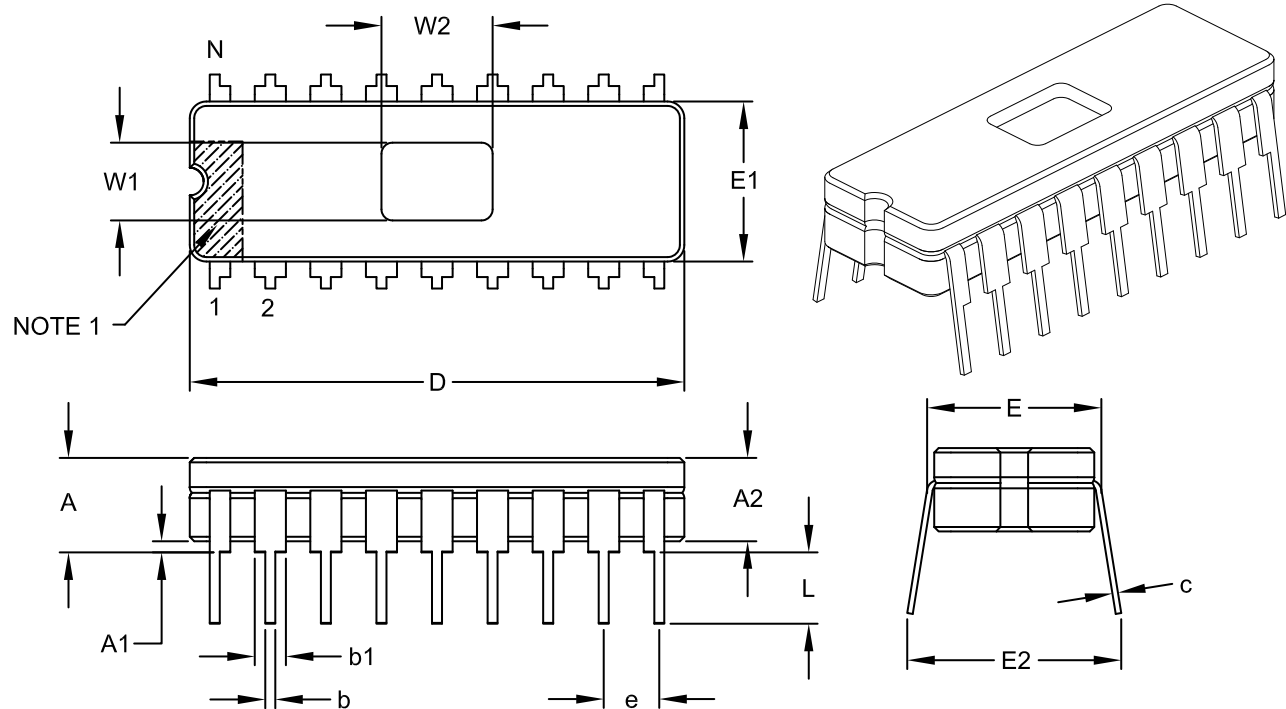

Dimension Limits	Units	INCHES		
		MIN	NOM	MAX
Number of Pins	N	18		
Pitch	e	.100 BSC		
Top to Seating Plane	A	-	-	.200
Ceramic Package Height	A2	.140	-	.175
Base to Seating Plane §	A1	.015	-	-
Shoulder to Shoulder Width	E	.308	-	.325
Ceramic Pkg. Width	E1	.280	.288	.296
Overall Length	D	.882	.890	.910
Tip to Seating Plane	L	.125	-	.200
Lead Thickness	c	.008	-	.014
Upper Lead Width	b1	.045	-	.065
Lower Lead Width	b	.015	-	.023
Overall Row Spacing	E2	.325	-	.410
Window Width	W1	.130	.140	.150
Window Length	W2	.190	.200	.210

**Notes:**

1. Pin 1 visual index feature may vary, but must be located within the hatched area.
2. § Significant Characteristic
3. Dimensioning and tolerancing per ASME Y14.5M

BSC: Basic Dimension. Theoretically exact value shown without tolerances.

Microchip Technology Drawing No. C04-010C

**Package Outlines and Dimensions**

**20-Lead Ceramic Dual In-Line with Window (JW) ~ .300" Body [CERDIP]**

**Note:** For the most current package drawings, please see the Microchip Packaging Specification located at <http://www.microchip.com/packaging>

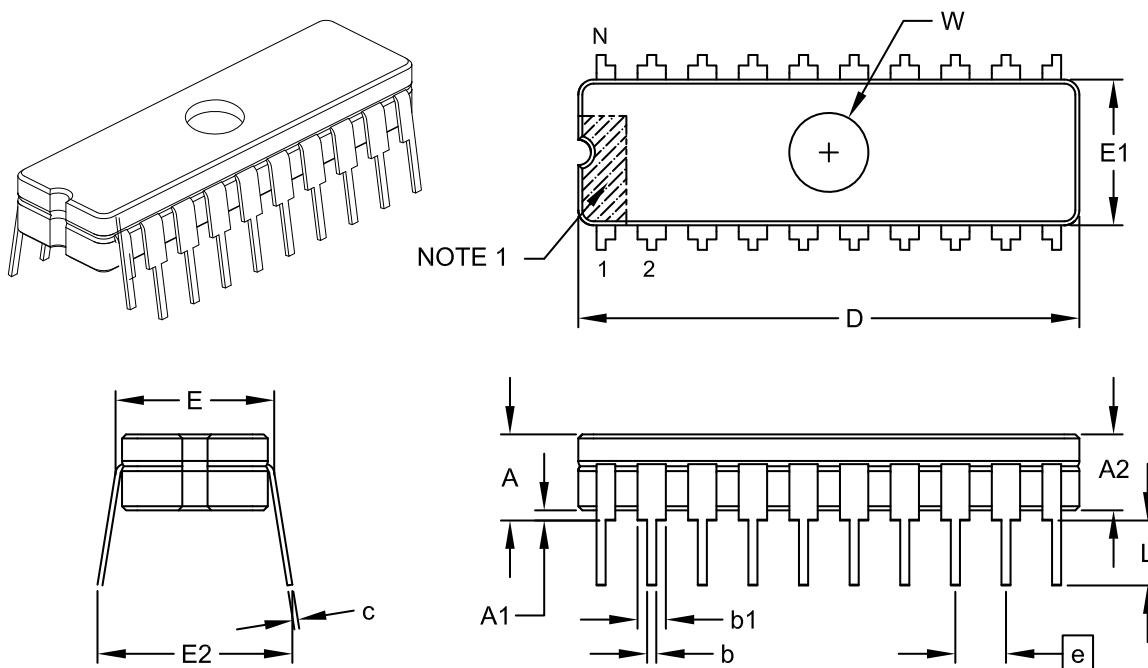

Dimension Limits	Units	INCHES		
		MIN	NOM	MAX
Number of Pins	N	20		
Pitch	e	.100 BSC		
Top to Seating Plane	A	-	-	.200
Ceramic Package Height	A2	.140	-	.175
Base to Seating Plane §	A1	.015	-	-
Shoulder to Shoulder Width	E	.308	-	.325
Ceramic Package Width	E1	.280	.288	.296
Overall Length	D	.942	.950	.970
Tip to Seating Plane	L	.125	-	.200
Lead Thickness	c	.008	-	.014
Upper Lead Width	b1	.045	-	.065
Lower Lead Width	b	.015	-	.023
Overall Row Spacing	E2	.325	-	.410
Window Diameter	W	.167	.170	.173

**Notes:**

1. Pin 1 visual index feature may vary, but must be located within the hatched area.
2. § Significant Characteristic
3. Dimensioning and tolerancing per ASME Y14.5M

BSC: Basic Dimension. Theoretically exact value shown without tolerances.

---



---

## Package Outlines and Dimensions

---



---

### 24-Lead Ceramic Dual In-Line (JG) ~ .600" Body [CERDIP]

**Note:** For the most current package drawings, please see the Microchip Packaging Specification located at <http://www.microchip.com/packaging>

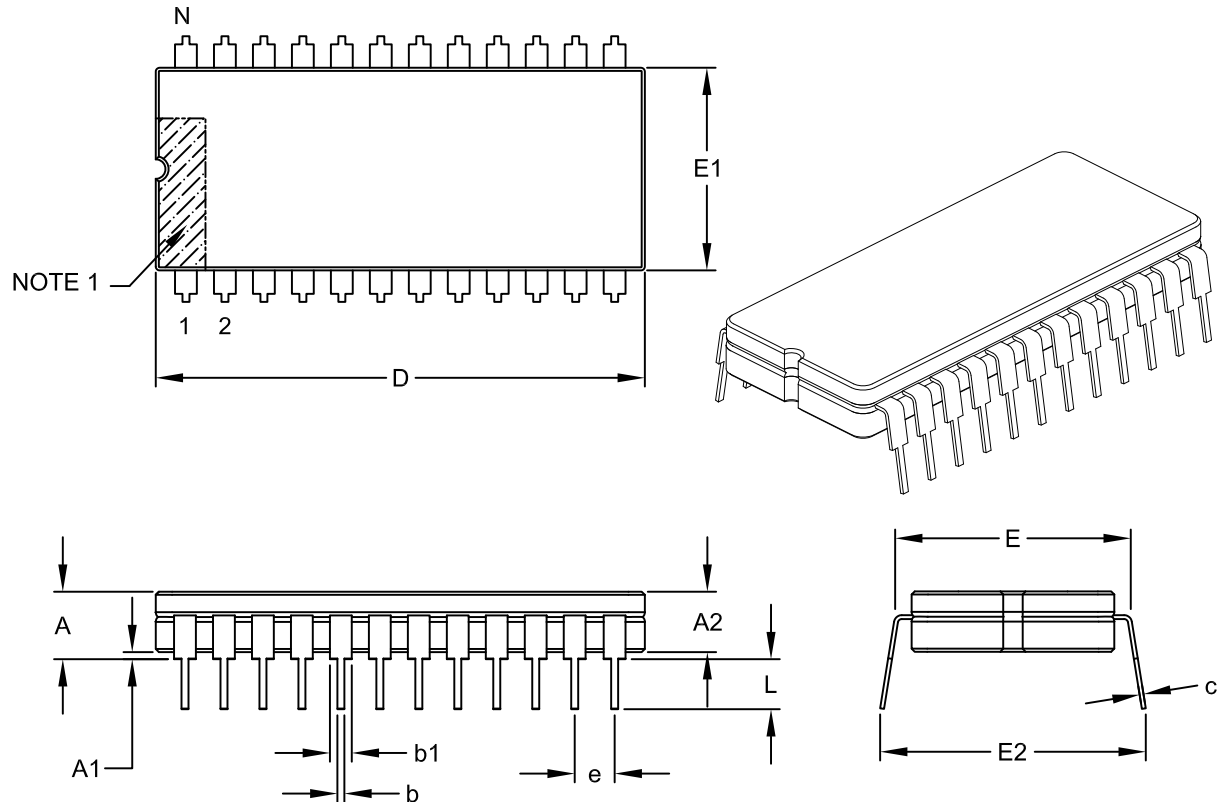

Dimension Limits	Units	INCHES		
		MIN	NOM	MAX
Number of Pins	N	24		
Pitch	e	.100 BSC		
Top to Seating Plane	A	-	-	.225
Ceramic Package Height	A2	.140	-	.175
Base to Seating Plane §	A1	.015	-	-
Shoulder to Shoulder Width	E	.590	-	.625
Ceramic Pkg. Width	E1	.510	.520	.540
Overall Length	D	1.240	1.250	1.270
Tip to Seating Plane	L	.125	-	.200
Lead Thickness	c	.008	-	.015
Upper Lead Width	b1	.045	-	.065
Lower Lead Width	b	.015	-	.023
Overall Row Spacing	E2	.620	-	.710

**Notes:**

1. Pin 1 visual index feature may vary, but must be located within the hatched area.
2. § Significant Characteristic
3. Dimensioning and tolerancing per ASME Y14.5M

BSC: Basic Dimension. Theoretically exact value shown without tolerances.

**Package Outlines and Dimensions**

**28-Lead Ceramic Dual In-Line (JN) ~ .600" Body [CERDIP]**

**Note:** For the most current package drawings, please see the Microchip Packaging Specification located at <http://www.microchip.com/packaging>

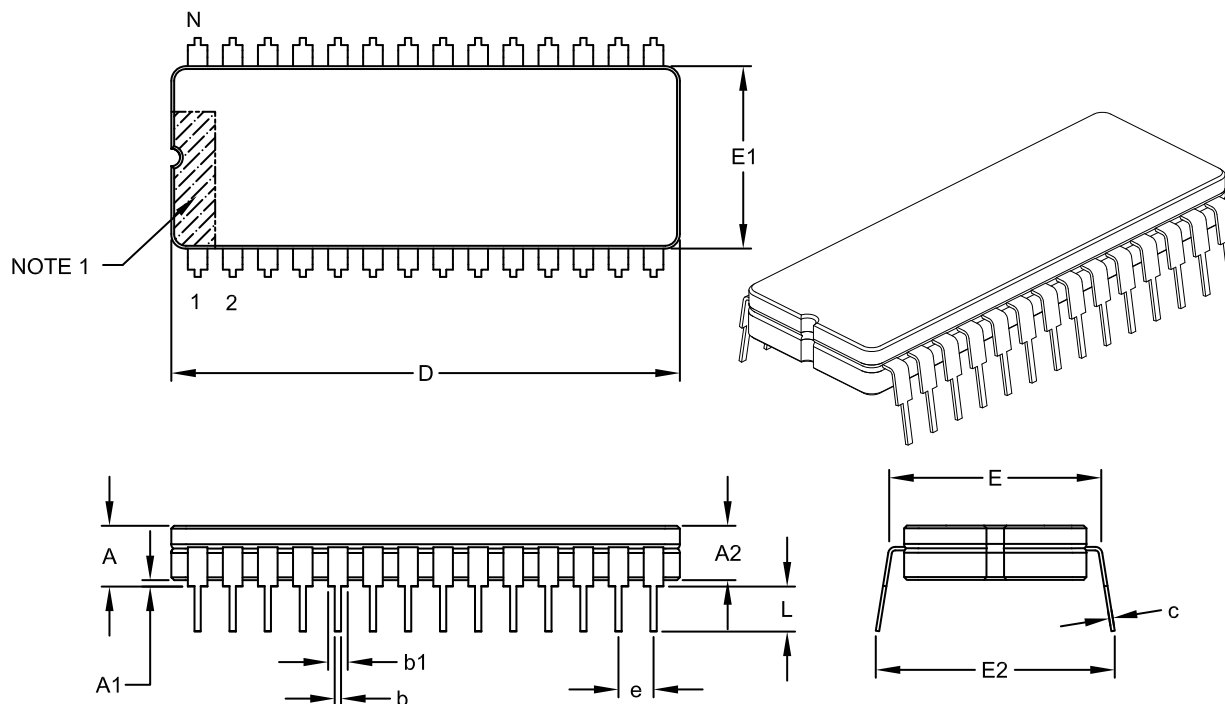

Dimension Limits	Units	INCHES		
		MIN	NOM	MAX
Number of Pins	N	28		
Pitch	e	.100 BSC		
Top to Seating Plane	A	-	-	.225
Ceramic Package Height	A2	.140	-	.175
Base to Seating Plane §	A1	.015	-	-
Shoulder to Shoulder Width	E	.590	-	.625
Ceramic Pkg. Width	E1	.510	.520	.540
Overall Length	D	1.440	1.450	1.470
Tip to Seating Plane	L	.125	-	.200
Lead Thickness	c	.008	-	.015
Upper Lead Width	b1	.045	-	.065
Lower Lead Width	b	.015	-	.023
Overall Row Spacing	E2	.620	-	.710

**Notes:**

1. Pin 1 visual index feature may vary, but must be located within the hatched area.
2. § Significant Characteristic
3. Dimensioning and tolerancing per ASME Y14.5M

BSC: Basic Dimension. Theoretically exact value shown without tolerances.

Microchip Technology Drawing No. C04-006C

---



---

## Package Outlines and Dimensions

---



---

### 28-Lead Ceramic Dual In-Line with Window (JW) ~ .300" Body [CERDIP]

**Note:** For the most current package drawings, please see the Microchip Packaging Specification located at <http://www.microchip.com/packaging>

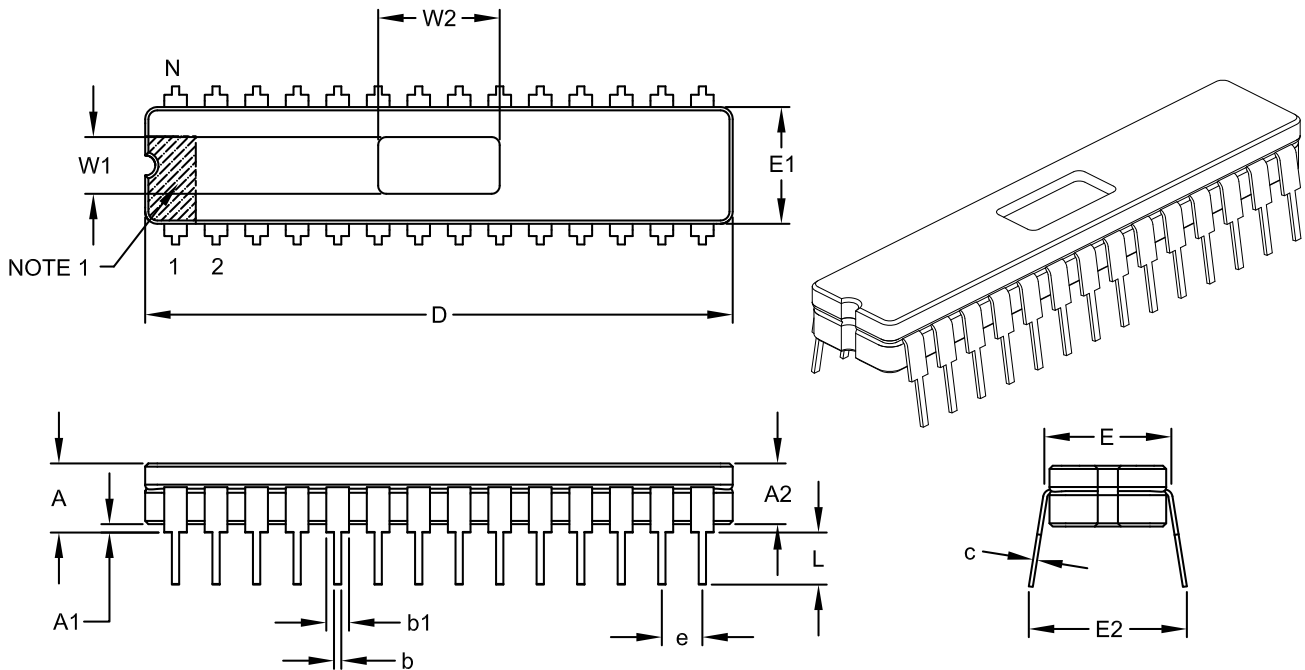

Dimension Limits	Units	INCHES		
		MIN	NOM	MAX
Number of Pins	N	28		
Pitch	e	.100 BSC		
Top to Seating Plane	A	-	-	.200
Ceramic Package Height	A2	.140	-	.175
Base to Seating Plane §	A1	.015	-	-
Shoulder to Shoulder Width	E	.308	-	.325
Ceramic Package Width	E1	.280	.288	.296
Overall Length	D	1.442	1.450	1.470
Tip to Seating Plane	L	.125	-	.200
Lead Thickness	c	.008	-	.014
Upper Lead Width	b1	.045	-	.065
Lower Lead Width	b	.015	-	.023
Overall Row Spacing	E2	.325	-	.410
Window Width	W1	.130	.140	.150
Window Length	W2	.290	.300	.310

**Notes:**

1. Pin 1 visual index feature may vary, but must be located within the hatched area.
2. § Significant Characteristic
3. Dimensioning and tolerancing per ASME Y14.5M

BSC: Basic Dimension. Theoretically exact value shown without tolerances.

Microchip Technology Drawing No. C04-080C

## Package Outlines and Dimensions

### 28-Lead Ceramic Dual In-Line with Window (JW) ~ .600" Body [CERDIP]

**Note:** For the most current package drawings, please see the Microchip Packaging Specification located at <http://www.microchip.com/packaging>

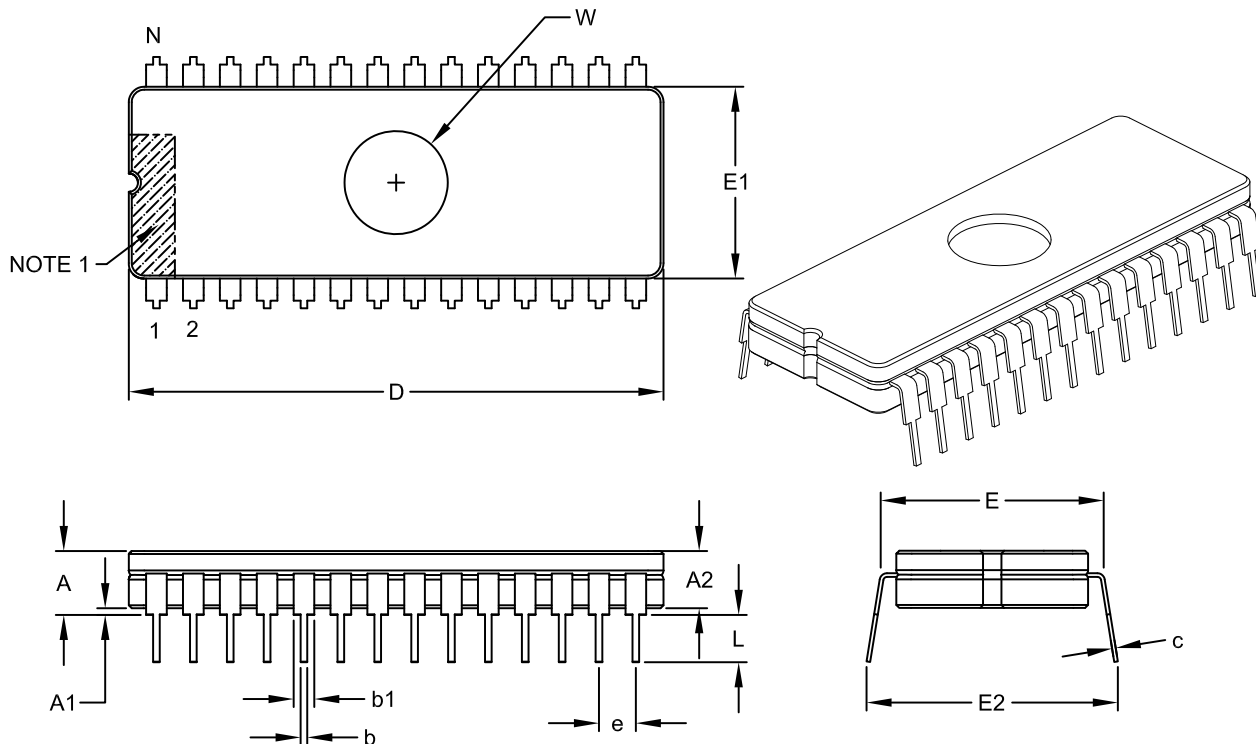

Dimension Limits	Units	INCHES		
		MIN	NOM	MAX
Number of Pins	N	28		
Pitch	e	.100 BSC		
Top to Seating Plane	A	-	-	.225
Ceramic Package Height	A2	.140	-	.175
Base to Seating Plane §	A1	.015	-	-
Shoulder to Shoulder Width	E	.590	-	.625
Ceramic Package Width	E1	.510	.520	.540
Overall Length	D	1.440	1.450	1.470
Tip to Seating Plane	L	.125	-	.200
Lead Thickness	c	.008	-	.015
Upper Lead Width	b1	.045	-	.065
Lower Lead Width	b	.015	-	.023
Overall Row Spacing	E2	.620	-	.710
Window Diameter	W	.270	.280	.290

**Notes:**

- Pin 1 visual index feature may vary, but must be located within the hatched area.
- § Significant Characteristic
- Dimensioning and tolerancing per ASME Y14.5M

BSC: Basic Dimension. Theoretically exact value shown without tolerances.

---



---

## Package Outlines and Dimensions

---



---

### 40-Lead Ceramic Dual In-Line (JK) ~ .600" Body [CERDIP]

**Note:** For the most current package drawings, please see the Microchip Packaging Specification located at <http://www.microchip.com/packaging>

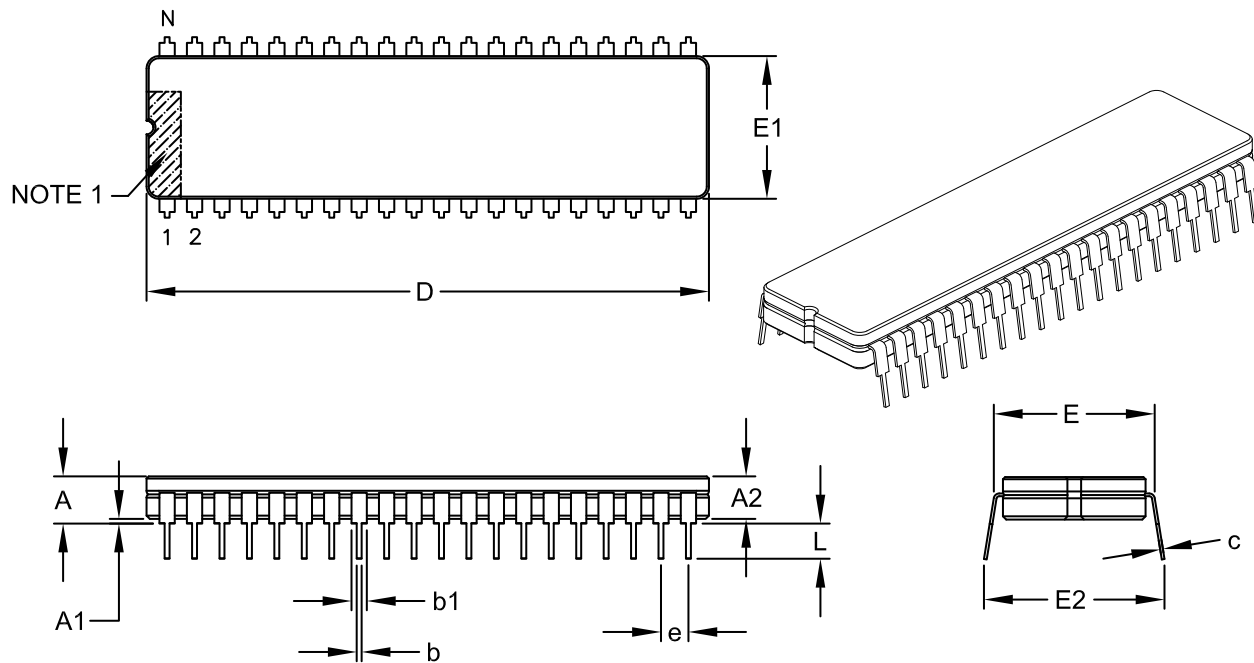

Dimension Limits	Units	INCHES		
		MIN	NOM	MAX
Number of Pins	N	40		
Pitch	e	.100 BSC		
Top to Seating Plane	A	-	-	.225
Ceramic Package Height	A2	.140	-	.175
Base to Seating Plane §	A1	.015	-	-
Shoulder to Shoulder Width	E	.590	-	.625
Ceramic Package Width	E1	.510	.520	.540
Overall Length	D	2.030	2.050	2.070
Tip to Seating Plane	L	.125	-	.200
Lead Thickness	c	.008	-	.015
Upper Lead Width	b1	.045	-	.065
Lower Lead Width	b	.015	-	.023
Overall Row Spacing	E2	.620	-	.710

**Notes:**

1. Pin 1 visual index feature may vary, but must be located within the hatched area.
2. § Significant Characteristic
3. Dimensioning and tolerancing per ASME Y14.5M

BSC: Basic Dimension. Theoretically exact value shown without tolerances.

**Package Outlines and Dimensions**

**40-Lead Ceramic Dual In-Line with Window (JW) ~ .600" Body [CERDIP]**

**Note:** For the most current package drawings, please see the Microchip Packaging Specification located at <http://www.microchip.com/packaging>

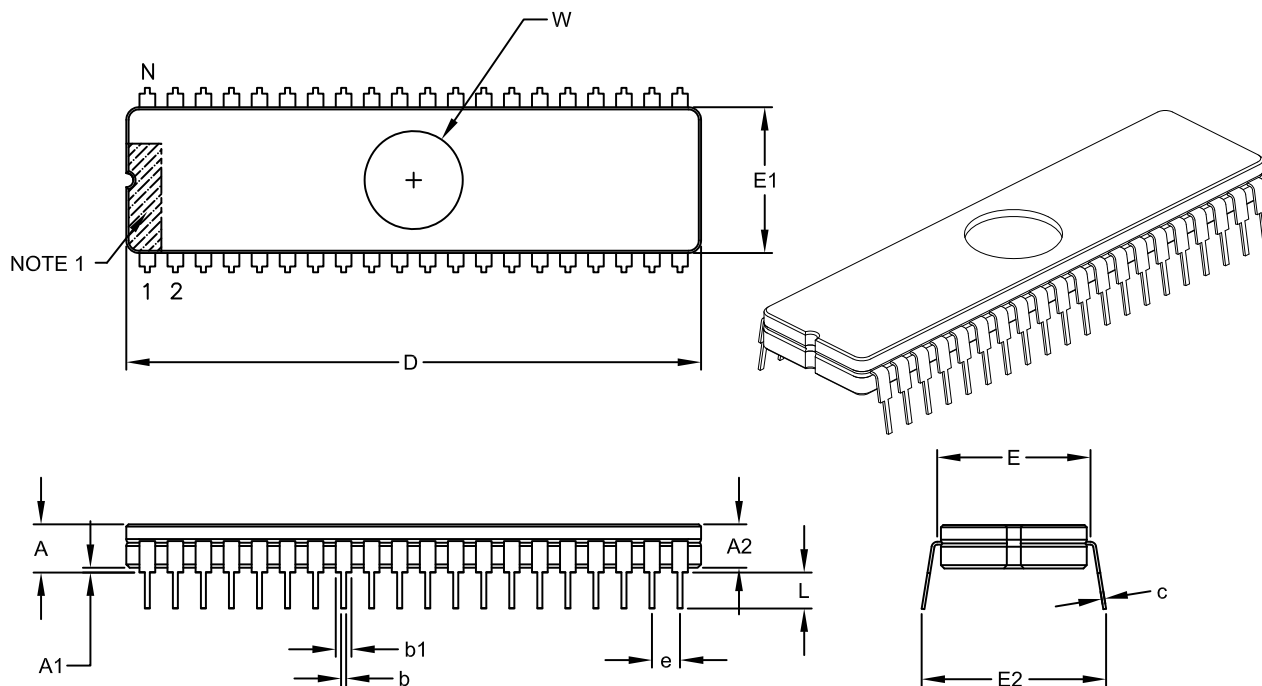

Dimension Limits	Units	INCHES		
		MIN	NOM	MAX
Number of Pins	N	40		
Pitch	e	.100 BSC		
Top to Seating Plane	A	-	-	.225
Ceramic Package Height	A2	.140	-	.175
Base to Seating Plane §	A1	.015	-	-
Shoulder to Shoulder Width	E	.590	-	.625
Ceramic Package Width	E1	.510	.520	.583
Overall Length	D	2.030	2.050	2.070
Tip to Seating Plane	L	.125	-	.200
Lead Thickness	c	.008	-	.015
Upper Lead Width	b1	.045	-	.065
Lower Lead Width	b	.015	-	.023
Overall Row Spacing	E2	.620	-	.710
Window Diameter	W	.340	.350	.360

**Notes:**

1. Pin 1 visual index feature may vary, but must be located within the hatched area.
2. § Significant Characteristic
3. Dimensioning and tolerancing per ASME Y14.5M

BSC: Basic Dimension. Theoretically exact value shown without tolerances.



---

---

**Package Outlines and Dimensions**

---

---

**CERQUAD**

**Package Outlines and Dimensions**

**68-Lead Ceramic Leaded (CL) Chip Carrier with Window – Square [CERQUAD]**

**Note:** For the most current package drawings, please see the Microchip Packaging Specification located at <http://www.microchip.com/packaging>

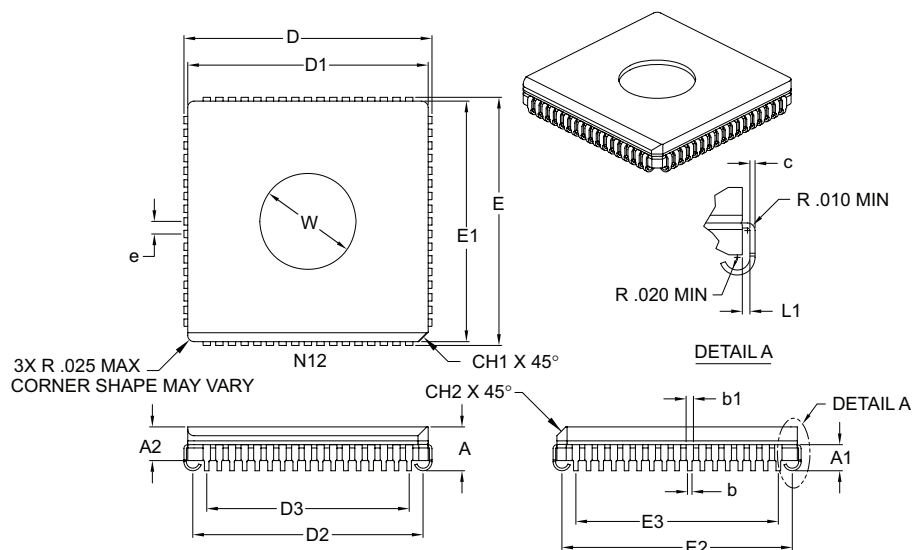

Dimension Limits	Units	INCHES		
		MIN	NOM	MAX
Number of Pins	N	68		
Pitch	e	.050 BSC		
Overall Height	A	.155	.172	.190
Package Thickness	A2	.132 REF		
Lead Height	A1	0.90	.100	.120
Side Chamfer	CH2	.035 REF		
Corner Chamfer	CH1	.040 REF		
Overall Package Width	E	.985	.990	.995
Overall Package Length	D	.985	.990	.995
Ceramic Package Width	E1	.930	.950	.965
Ceramic Package Length	D1	.930	.950	.965
Overall Lead Centers	E3	.800 REF		
Overall Lead Centers	D3	.800 REF		
Footprint Width	E2	.880	.910	.940
Footprint Length	D2	.880	.910	.940
Lead Length	L1	.006	–	–
Lead Thickness	c	.006	.007	.010
Upper Lead Width	b1	.026	.029	.032
Lower Lead Width	b	.017	.019	.021
Window Diameter	W	.370	.380	.390

**Notes:**

- Dimensions D1 and E1 do not include glass protrusion. These protrusions shall not exceed .005" per side.
- Dimensioning and tolerancing per ASME Y14.5M.

BSC: Basic Dimension. Theoretically exact value shown without tolerances.

REF: Reference Dimension, usually without tolerance, for information purposes only.

Microchip Technology Drawing C04-097B

**Footprint Outlines and Dimensions**

**68-Lead Ceramic Leaded (CL) Chip Carrier with Window - Square [CERQUAD]**

**Note:** For the most current package drawings, please see the Microchip Packaging Specification located at <http://www.microchip.com/packaging>

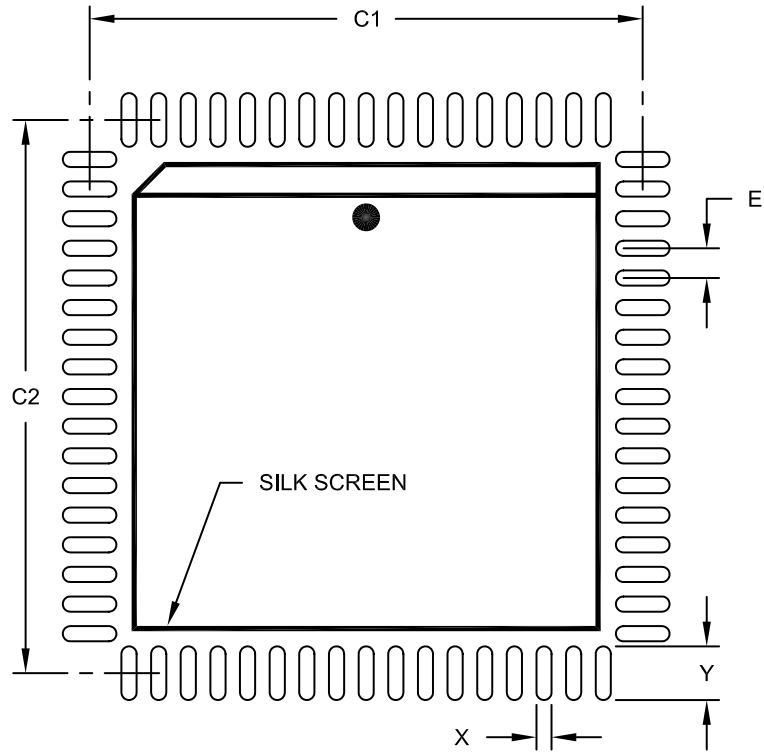

**RECOMMENDED LAND PATTERN**

		Units	INCHES		
Dimension Limits			MIN	NOM	MAX
Contact Pitch	E		.050 BSC		
Contact Pad Spacing	C1			.933	
Contact Pad Spacing	C2			.933	
Contact Pad Width (X68)	X1				.026
Contact Pad Length (X68)	Y1				.091

**Notes:**

1. Dimensioning and tolerancing per ASME Y14.5M

BSC: Basic Dimension. Theoretically exact value shown without tolerances.

Microchip Technology Drawing No. C04-2097A

**Package Outlines and Dimensions**

**84-Lead Ceramic Leaded (CL) Chip Carrier with Window – Square [CERQUAD]**

**Note:** For the most current package drawings, please see the Microchip Packaging Specification located at <http://www.microchip.com/packaging>

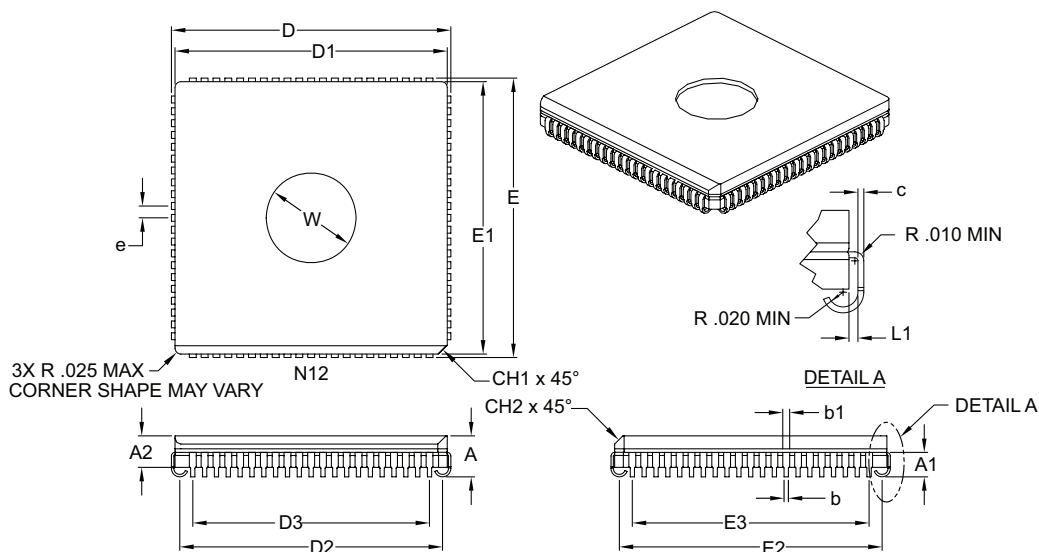

Dimension Limits	Units	INCHES		
		MIN	NOM	MAX
Number of Pins	N	84		
Pitch	e	.050 BSC		
Overall Height	A	.155	.172	.190
Package Thickness	A2	.132 REF		
Lead Height	A1	0.90	.100	.120
Side Chamfer	CH2	.035 REF		
Corner Chamfer	CH1	.040 REF		
Overall Package Width	E	1.185	1.190	1.195
Overall Package Length	D	1.185	1.190	1.195
Ceramic Package Width	E1	1.130	1.150	1.165
Ceramic Package Length	D1	1.130	1.150	1.165
Overall Lead Centers	E3	1.00 REF		
Overall Lead Centers	D3	1.00 REF		
Footprint Width	E2	1.080	1.110	1.140
Footprint Length	D2	1.080	1.110	1.140
Lead Length	L1	.006	–	–
Lead Thickness	c	.006	.007	.010
Lower Lead Width	b	.017	.019	.021
Upper Lead Width	b1	.026	.029	.032
Window Diameter	W	.395	.400	.405

**Notes:**

- Dimensions D1 and E1 do not include glass protrusion. These protrusions shall not exceed .005" per side.
- Dimensioning and tolerancing per ASME Y14.5M.

BSC: Basic Dimension. Theoretically exact value shown without tolerances.

REF: Reference Dimension, usually without tolerance, for information purposes only.

---



---

## Footprint Outlines and Dimensions

---



---

### 84-Lead Ceramic Leaded (CL) Chip Carrier with Window - Square [CERQUAD]

**Note:** For the most current package drawings, please see the Microchip Packaging Specification located at <http://www.microchip.com/packaging>

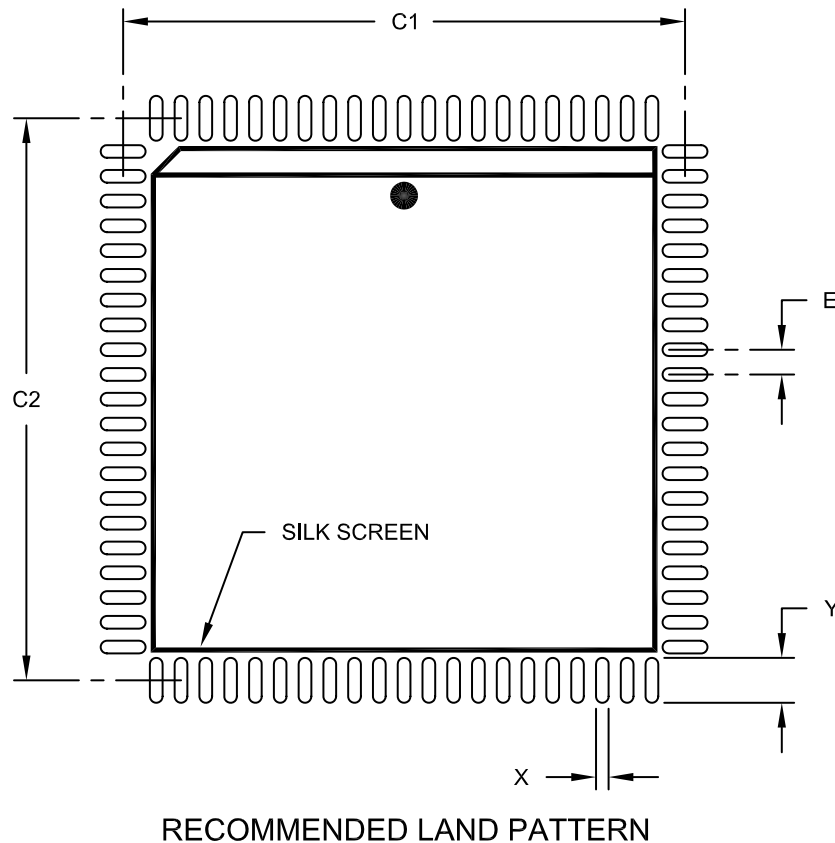

		Units	INCHES		
		Dimension Limits	MIN	NOM	MAX
Contact Pitch	E			.050	
Contact Pad Spacing	C1			1.134	
Contact Pad Spacing	C2			1.134	
Contact Pad Width (X84)	X				.026
Contact Pad Length (X84)	Y				.091

**Notes:**

1. Dimensioning and tolerancing per ASME Y14.5M

BSC: Basic Dimension. Theoretically exact value shown without tolerances.

Microchip Technology Drawing No. C04-2112A



**MICROCHIP**

---

---

**Package Outlines and Dimensions**

---

---

NOTES:

---

---

**Package Outlines and Dimensions**

---

---

**DDPAK**

## Package Outlines and Dimensions

### 3-Lead Plastic (EB) [DDPAK]

**Note:** For the most current package drawings, please see the Microchip Packaging Specification located at <http://www.microchip.com/packaging>

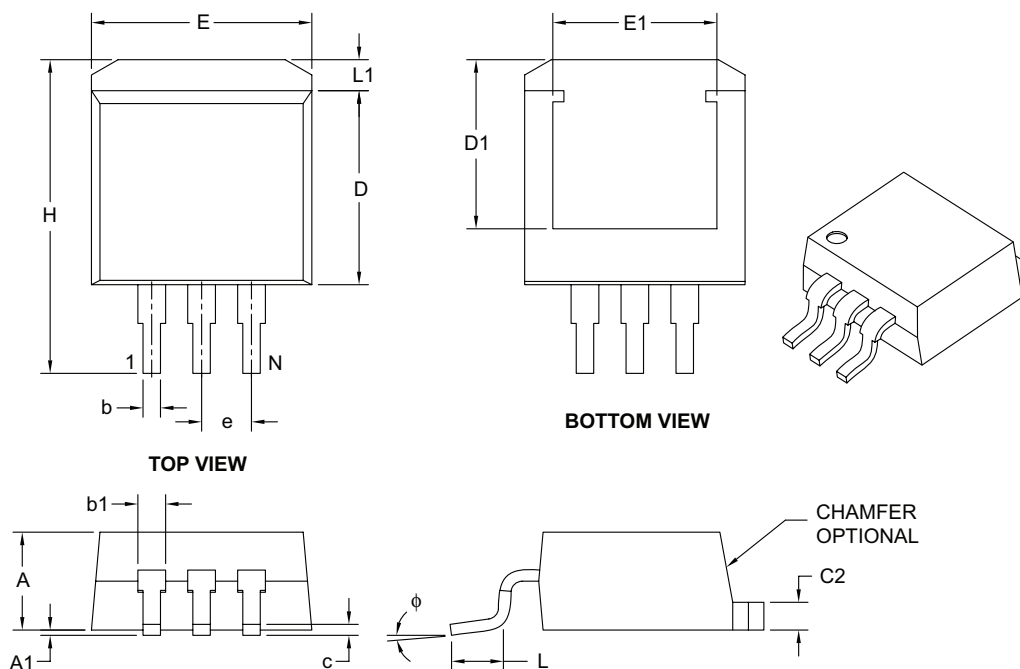

Dimension Limits	Units	INCHES		
		MIN	NOM	MAX
Number of Pins	N	3		
Pitch	e	.100 BSC		
Overall Height	A	.160	–	.190
Standoff §	A1	.000	–	.010
Overall Width	E	.380	–	.420
Exposed Pad Width	E1	.245	–	–
Molded Package Length	D	.330	–	.380
Overall Length	H	.549	–	.625
Exposed Pad Length	D1	.270	–	–
Lead Thickness	c	.014	–	.029
Pad Thickness	C2	.045	–	.065
Lower Lead Width	b	.020	–	.039
Upper Lead Width	b1	.045	–	.070
Foot Length	L	.068	–	.110
Pad Length	L1	–	–	.067
Foot Angle	$\phi$	0°	–	8°

**Notes:**

- § Significant Characteristic.
- Dimensions D and E do not include mold flash or protrusions. Mold flash or protrusions shall not exceed .005" per side.
- Dimensioning and tolerancing per ASME Y14.5M.

BSC: Basic Dimension. Theoretically exact value shown without tolerances.



---



---

## Footprint Outlines and Dimensions

---



---

### 3-Lead Plastic (EB) [DDPAK]

**Note:** For the most current package drawings, please see the Microchip Packaging Specification located at <http://www.microchip.com/packaging>

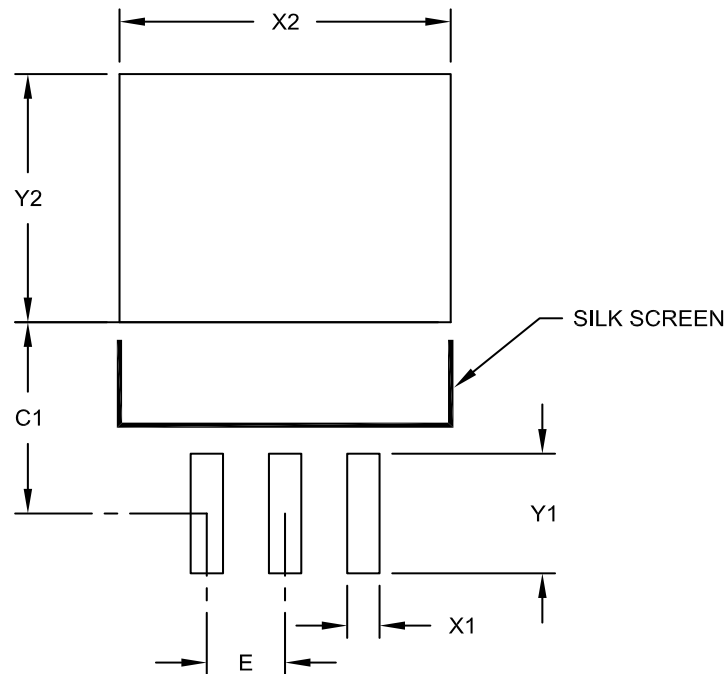

RECOMMENDED LAND PATTERN

	Units	INCHES		
		MIN	NOM	MAX
	Dimension Limits			
Contact Pitch	E	.100 BSC		
Pad Width	X2			.423
Pad Length	Y2			.327
Contact Pad Spacing	C1		.252	
Contact Pad Width (X3)	X1			.041
Contact Pad Length (X3)	Y1			.157

**Notes:**

1. Dimensioning and tolerancing per ASME Y14.5M

BSC: Basic Dimension. Theoretically exact value shown without tolerances.

Microchip Technology Drawing No. C04-2011A

## Package Outlines and Dimensions

### 5-Lead Plastic (ET) [DDPAK]

**Note:** For the most current package drawings, please see the Microchip Packaging Specification located at <http://www.microchip.com/packaging>

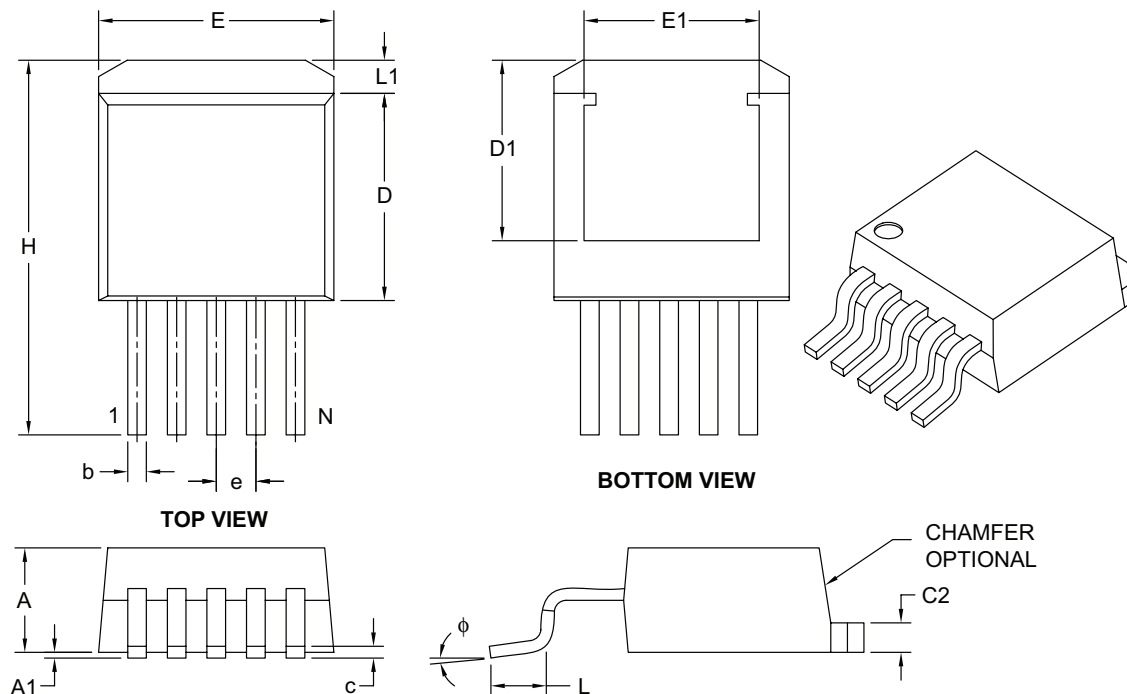

Dimension Limits	Units	INCHES		
		MIN	NOM	MAX
Number of Pins	N	5		
Pitch	e	.067 BSC		
Overall Height	A	.160	–	.190
Standoff §	A1	.000	–	.010
Overall Width	E	.380	–	.420
Exposed Pad Width	E1	.245	–	–
Molded Package Length	D	.330	–	.380
Overall Length	H	.549	–	.625
Exposed Pad Length	D1	.270	–	–
Lead Thickness	c	.014	–	.029
Pad Thickness	C2	.045	–	.065
Lead Width	b	.020	–	.039
Foot Length	L	.068	–	.110
Pad Length	L1	–	–	.067
Foot Angle	$\phi$	0°	–	8°

**Notes:**

- § Significant Characteristic.
- Dimensions D and E do not include mold flash or protrusions. Mold flash or protrusions shall not exceed .005" per side.
- Dimensioning and tolerancing per ASME Y14.5M.

BSC: Basic Dimension. Theoretically exact value shown without tolerances.

## Footprint Outlines and Dimensions

### 5-Lead Plastic (ET) [DDPAK]

**Note:** For the most current package drawings, please see the Microchip Packaging Specification located at <http://www.microchip.com/packaging>

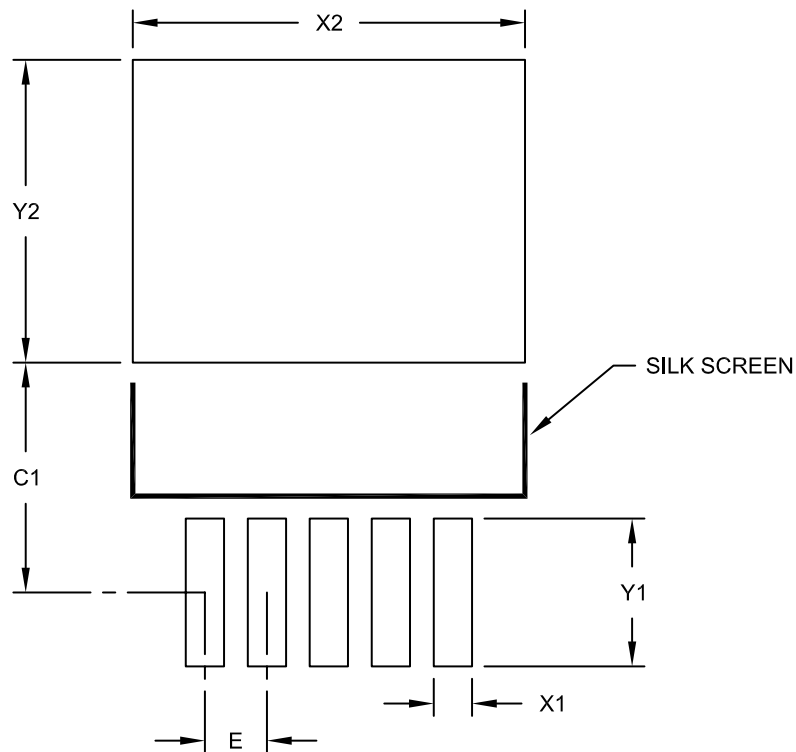

**RECOMMENDED LAND PATTERN**

Dimension Limits	Units	INCHES		
		MIN	NOM	MAX
Contact Pitch	E	.067 BSC		
Optional Center Pad Width	X2			.423
Optional Center Pad Length	Y2			.327
Contact Pad Spacing	C1		.248	
Contact Pad Width (X5)	X1			.041
Contact Pad Length (X5)	Y1			.159

**Notes:**

1. Dimensioning and tolerancing per ASME Y14.5M

BSC: Basic Dimension. Theoretically exact value shown without tolerances.

Microchip Technology Drawing No. C04-2012A

## Package Outlines and Dimensions

### 7-Lead Plastic (EK) [DDPAK]

**Note:** For the most current package drawings, please see the Microchip Packaging Specification located at <http://www.microchip.com/packaging>

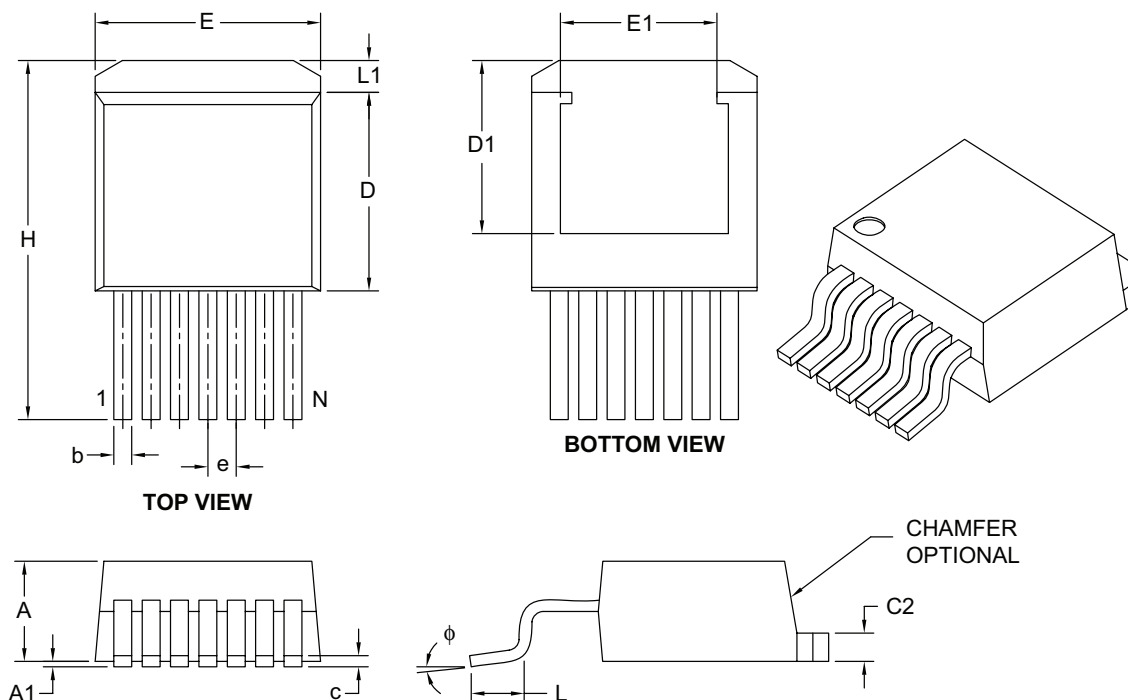

Dimension Limits	Units	INCHES		
		MIN	NOM	MAX
Number of Pins	N	7		
Pitch	e	.050 BSC		
Overall Height	A	.160	–	.190
Standoff §	A1	.000	–	.010
Overall Width	E	.380	–	.420
Exposed Pad Width	E1	.245	–	–
Molded Package Length	D	.330	–	.380
Overall Length	H	.549	–	.625
Exposed Pad Length	D1	.270	–	–
Lead Thickness	c	.014	–	.029
Pad Thickness	C2	.045	–	.065
Lead Width	b	.020	–	.037
Foot Length	L	.068	–	.110
Pad Length	L1	–	–	.067
Foot Angle	φ	0°	–	8°

**Notes:**

- § Significant Characteristic.
- Dimensions D and E do not include mold flash or protrusions. Mold flash or protrusions shall not exceed .005" per side.
- Dimensioning and tolerancing per ASME Y14.5M.

BSC: Basic Dimension. Theoretically exact value shown without tolerances.

Microchip Technology Drawing C04-015B

---



---

## Footprint Outlines and Dimensions

---



---

### 7-Lead Plastic (EK) [DDPAK]

**Note:** For the most current package drawings, please see the Microchip Packaging Specification located at <http://www.microchip.com/packaging>

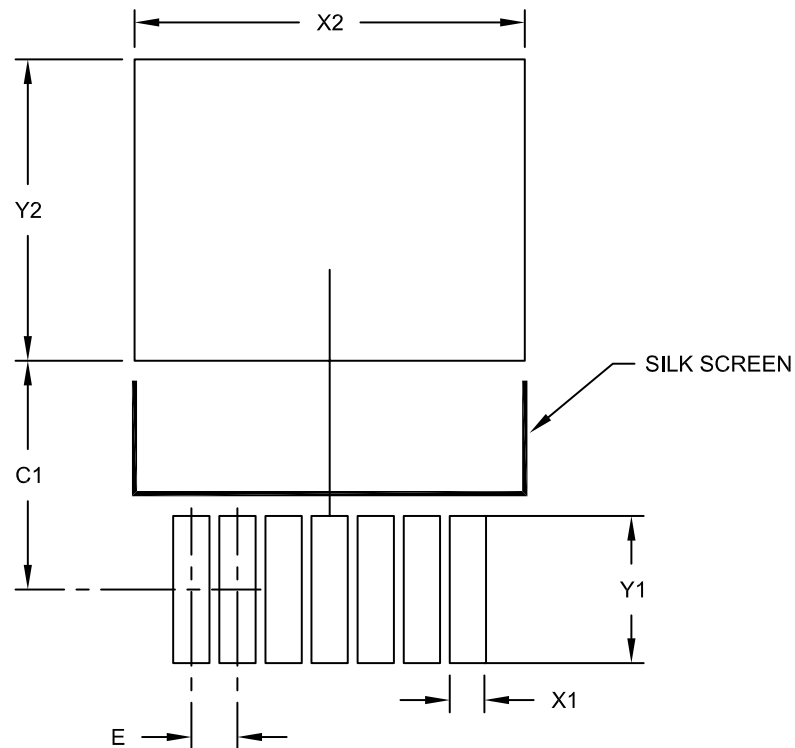

RECOMMENDED LAND PATTERN

Dimension Limits	Units	INCHES		
		MIN	NOM	MAX
Contact Pitch	E	.050 BSC		
Optional Center Pad Width	X2			.423
Optional Center Pad Length	Y2			.327
Contact Pad Spacing	C1		.248	
Contact Pad Width (X7)	X1			.039
Contact Pad Length (X7)	Y1			.159

**Notes:**

1. Dimensioning and tolerancing per ASME Y14.5M

BSC: Basic Dimension. Theoretically exact value shown without tolerances.

Microchip Technology Drawing No. C04-2015B



**MICROCHIP**

---

---

**Package Outlines and Dimensions**

---

---

NOTES:

---

---

**Package Outlines and Dimensions**

---

---

**SC70**

**Package Outlines and Dimensions**

**3-Lead Plastic Small Outline Transistor (LB) [SC70]**

**Note:** For the most current package drawings, please see the Microchip Packaging Specification located at <http://www.microchip.com/packaging>

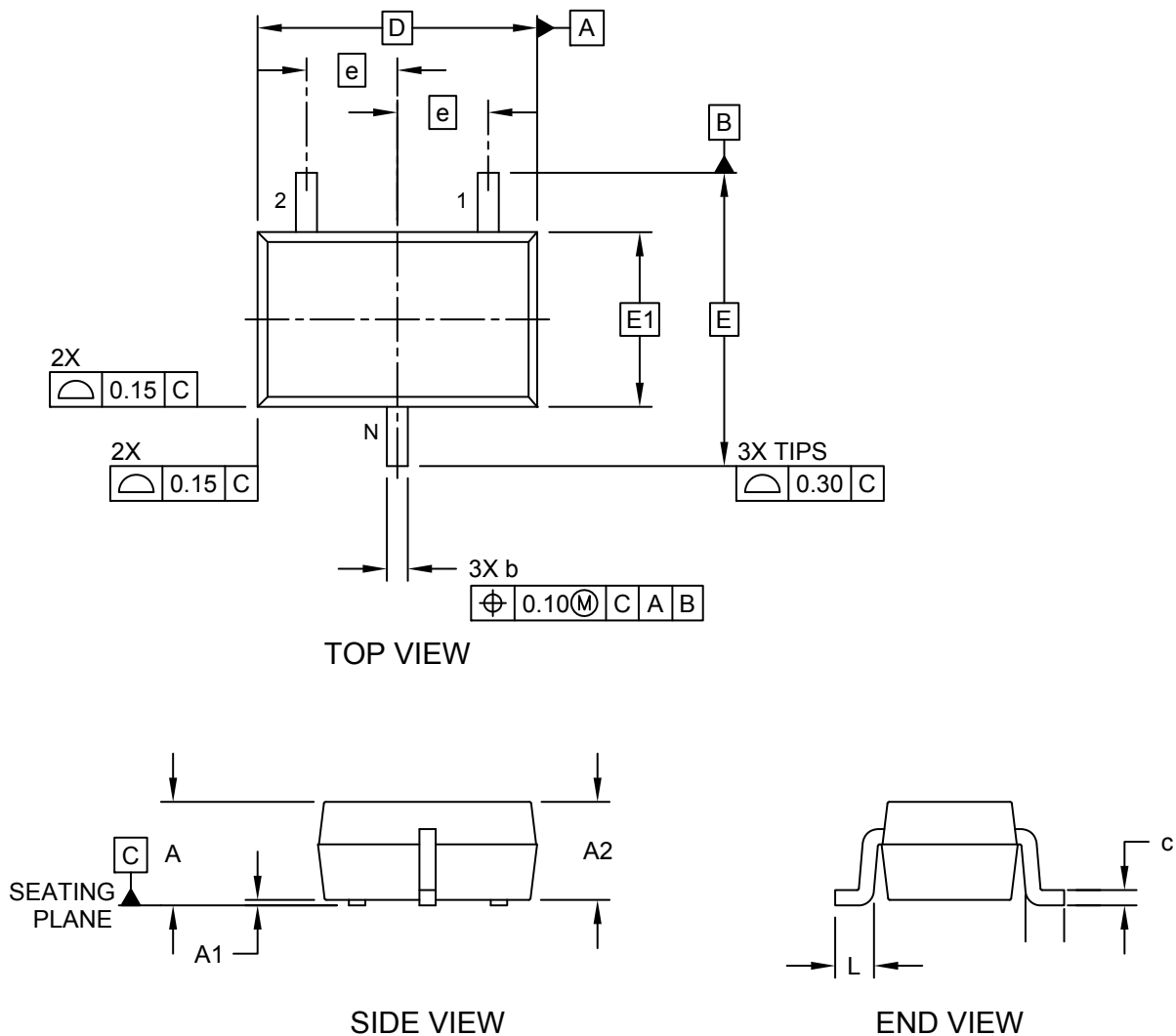



---



---

## Package Outlines and Dimensions

---



---

### 3-Lead Plastic Small Outline Transistor (LB) [SC70]

**Note:** For the most current package drawings, please see the Microchip Packaging Specification located at <http://www.microchip.com/packaging>

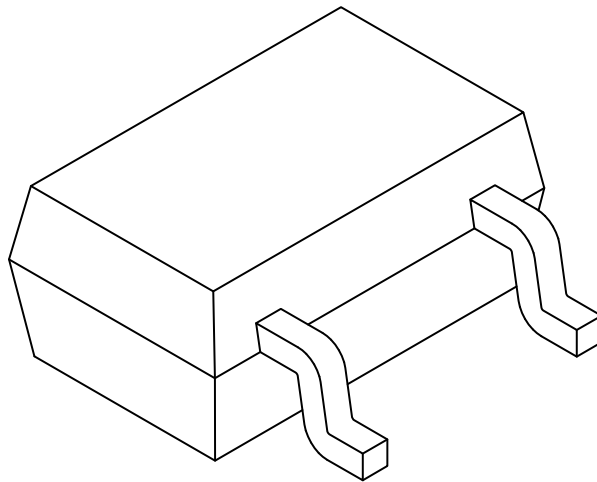

		Units	MILLIMETERS		
Dimension Limits			MIN	NOM	MAX
Number of Pins	N		3		
Pitch	e		0.65 BSC		
Overall Height	A	0.80	-	-	1.10
Standoff	A1	0.00	-	-	0.10
Molded Package Thickness	A2	0.80	-	-	1.00
Overall Length	D		2.00 BSC		
Exposed Pad Length	D2	2.50	2.60	2.60	2.70
Overall Width	E		2.10 BSC		
Exposed Pad Width	E1		1.25 BSC		
Terminal Width	b	0.15	-	-	0.40
Terminal Length	L	0.10	0.20	0.20	0.46
Lead Thickness	c	0.20	-	-	0.26

**Notes:**

1. Dimensions D and E1 do not include mold flash or protrusions. Mold flash or protrusions shall not exceed 0.15mm per side.
2. Dimensioning and tolerancing per ASME Y14.5M  
 BSC: Basic Dimension. Theoretically exact value shown without tolerances.  
 REF: Reference Dimension, usually without tolerance, for information purposes only.

**Footprint Outlines and Dimensions**

**3-Lead Plastic Small Outline Transistor (LB) [SC70]**

**Note:** For the most current package drawings, please see the Microchip Packaging Specification located at <http://www.microchip.com/packaging>

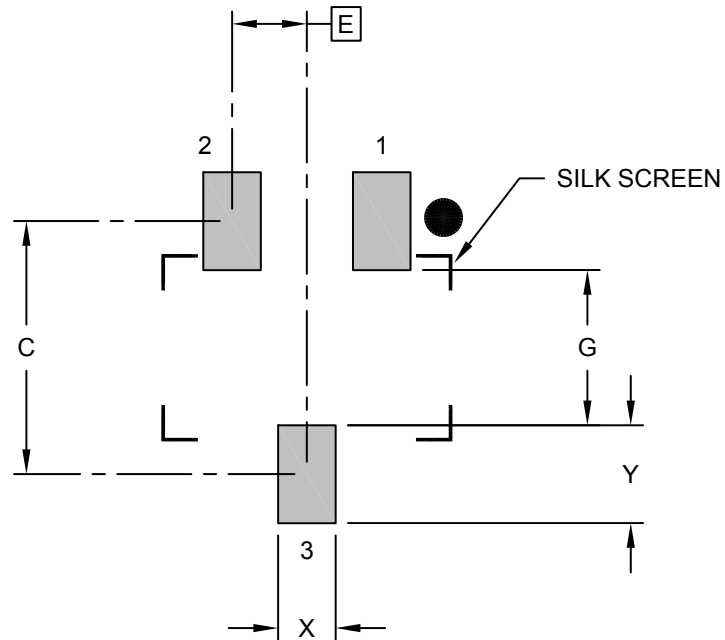

**RECOMMENDED LAND PATTERN**

Dimension Limits	Units	MILLIMETERS		
		MIN	NOM	MAX
Contact Pitch	E	0.65 BSC		
Contact Pad Spacing	C		2.20	
Contact Pad Width	X			0.50
Contact Pad Length	Y			0.85
Distance Between Pads	G	1.25		

**Notes:**

1. Dimensioning and tolerancing per ASME Y14.5M  
BSC: Basic Dimension. Theoretically exact value shown without tolerances.

**Package Outlines and Dimensions**

**5-Lead Plastic Small Outline Transistor (LT) [SC70]**

**Note:** For the most current package drawings, please see the Microchip Packaging Specification located at <http://www.microchip.com/packaging>

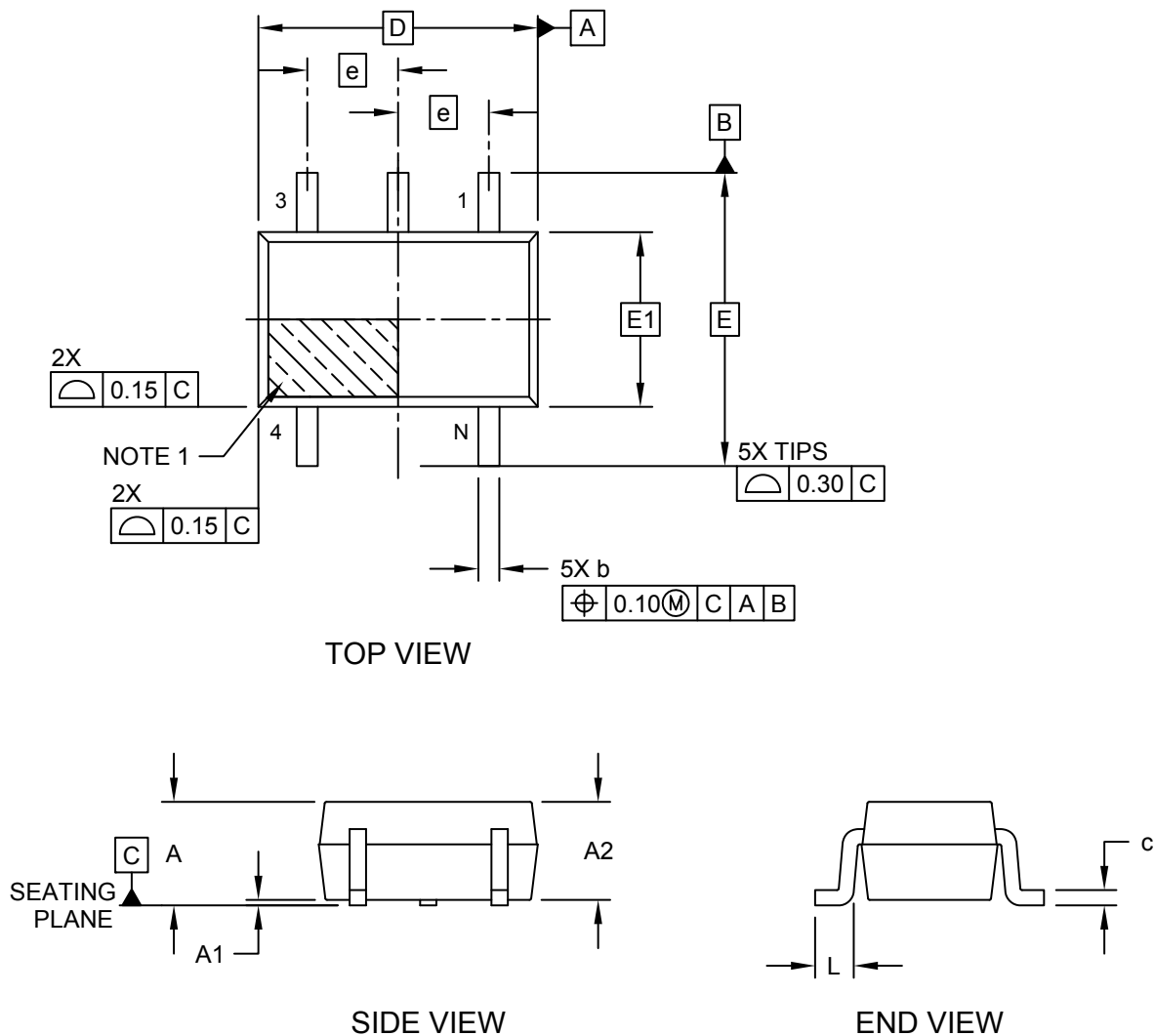

**Package Outlines and Dimensions**

**5-Lead Plastic Small Outline Transistor (LT) [SC70]**

**Note:** For the most current package drawings, please see the Microchip Packaging Specification located at <http://www.microchip.com/packaging>

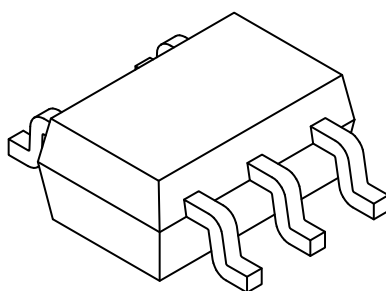

		Units	MILLIMETERS		
Dimension Limits			MIN	NOM	MAX
Number of Pins	N		5		
Pitch	e		0.65 BSC		
Overall Height	A	0.80	-	1.10	
Standoff	A1	0.00	-	0.10	
Molded Package Thickness	A2	0.80	-	1.00	
Overall Length	D		2.00 BSC		
Exposed Pad Length	D2	2.50	2.60	2.70	
Overall Width	E		2.10 BSC		
Exposed Pad Width	E1		1.25 BSC		
Terminal Width	b	0.15	-	0.40	
Terminal Length	L	0.10	0.20	0.46	
Lead Thickness	c	0.08	-	0.26	

**Notes:**

1. Pin 1 visual index feature may vary, but must be located within the hatched area.
2. Dimensions D and E1 do not include mold flash or protrusions. Mold flash or protrusions shall not exceed 0.15mm per side.
3. Dimensioning and tolerancing per ASME Y14.5M

BSC: Basic Dimension. Theoretically exact value shown without tolerances.

REF: Reference Dimension, usually without tolerance, for information purposes only.

---



---

## Footprint Outlines and Dimensions

---



---

### 5-Lead Plastic Small Outline Transistor (LT) [SC70]

**Note:** For the most current package drawings, please see the Microchip Packaging Specification located at <http://www.microchip.com/packaging>

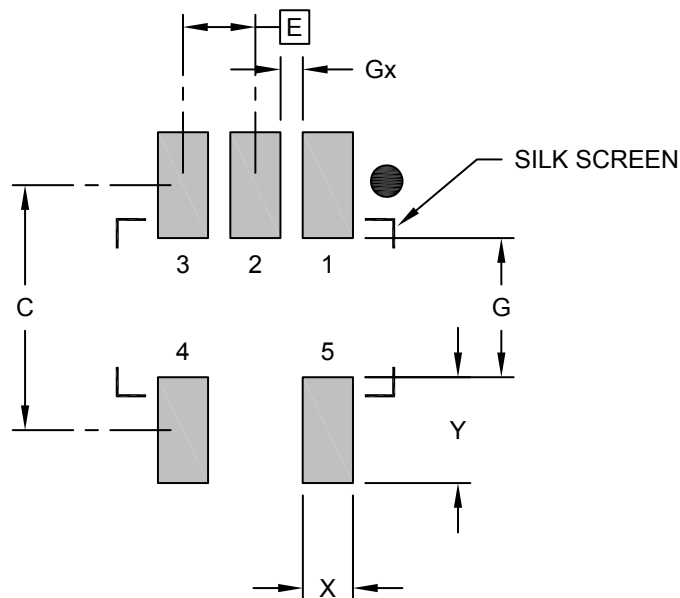

RECOMMENDED LAND PATTERN

Dimension Limits	Units	MILLIMETERS		
		MIN	NOM	MAX
Contact Pitch	E	0.65 BSC		
Contact Pad Spacing	C		2.20	
Contact Pad Width	X			0.45
Contact Pad Length	Y			0.95
Distance Between Pads	G	1.25		
Distance Between Pads	Gx	0.20		

**Notes:**

1. Dimensioning and tolerancing per ASME Y14.5M

BSC: Basic Dimension. Theoretically exact value shown without tolerances.

Microchip Technology Drawing No. C04-2061B

## Package Outlines and Dimensions

### 5-Lead Plastic Small Outline Transistor (LTY) [SC70]

**Note:** For the most current package drawings, please see the Microchip Packaging Specification located at <http://www.microchip.com/packaging>

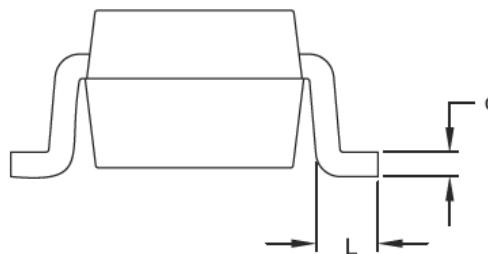
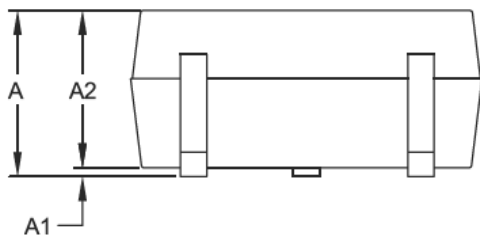
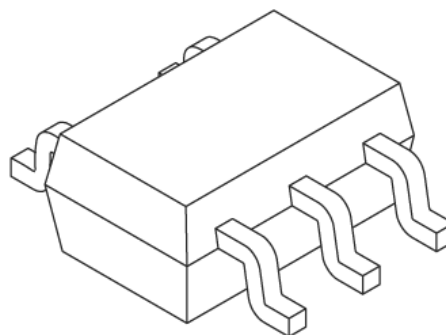
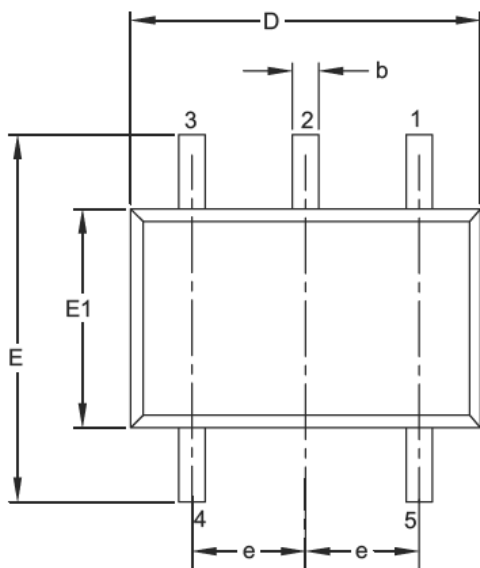

Dimension Limits	Units	MILLIMETERS		
		MIN	NOM	MAX
Number of Pins	N	5		
Pitch	e	0.65 BSC		
Overall Height	A	0.80		1.10
Molded Package Thickness	A2	0.80		1.00
Standoff	A1	0.00		0.10
Overall Width	E	1.80	2.10	2.40
Molded Package Width	E1	1.15	1.25	1.35
Overall Length	D	1.80	2.00	2.25
Foot Length	L	0.10	0.20	0.46
Lead Thickness	c	0.08		0.26
Lead Width	b	0.15		0.40

**Notes:**

- Dimensions D and E1 do not include mold flash or protrusions. Mold flash or protrusions shall not exceed 0.127 mm per side.
- Dimensioning and tolerancing per ASME Y14.5M.

BSC: Basic Dimension. Theoretically exact value shown without tolerances.

---



---

## Footprint Outlines and Dimensions

---



---

### 5-Lead Plastic Small Outline Transistor (LTY) [SC70]

**Note:** For the most current package drawings, please see the Microchip Packaging Specification located at <http://www.microchip.com/packaging>

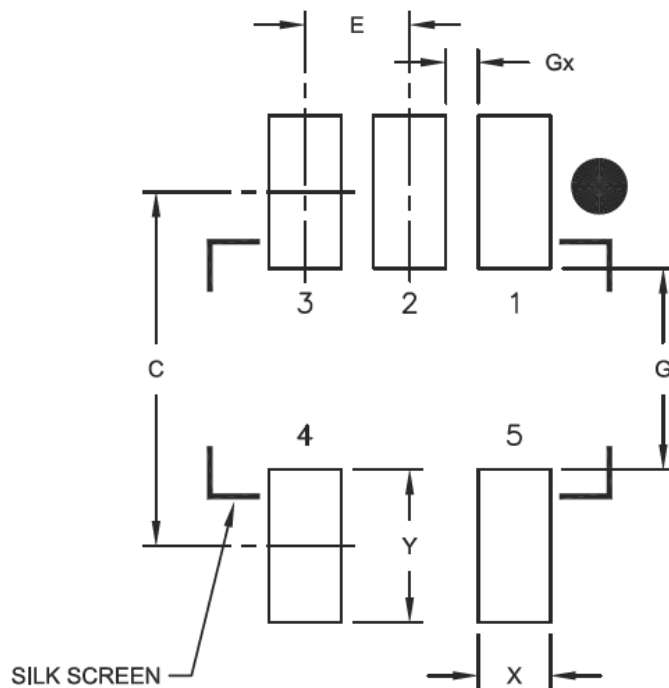

**RECOMMENDED LAND PATTERN**

Dimension Limits	Units	MILLIMETERS		
		MIN	NOM	MAX
Contact Pitch	E	0.65 BSC		
Contact Pad Spacing	C		2.20	
Contact Pad Width	X			0.45
Contact Pad Length	Y			0.95
Distance Between Pads	G	1.25		
Distance Between Pads	Gx	0.20		

**Notes:**

1. Dimensioning and tolerancing per ASME Y14.5M

BSC: Basic Dimension. Theoretically exact value shown without tolerances.

Microchip Technology Drawing No. C04-2061A

**Package Outlines and Dimensions**

**6-Lead Plastic Small Outline Transistor (LT) [SC70]**

**Note:** For the most current package drawings, please see the Microchip Packaging Specification located at <http://www.microchip.com/packaging>

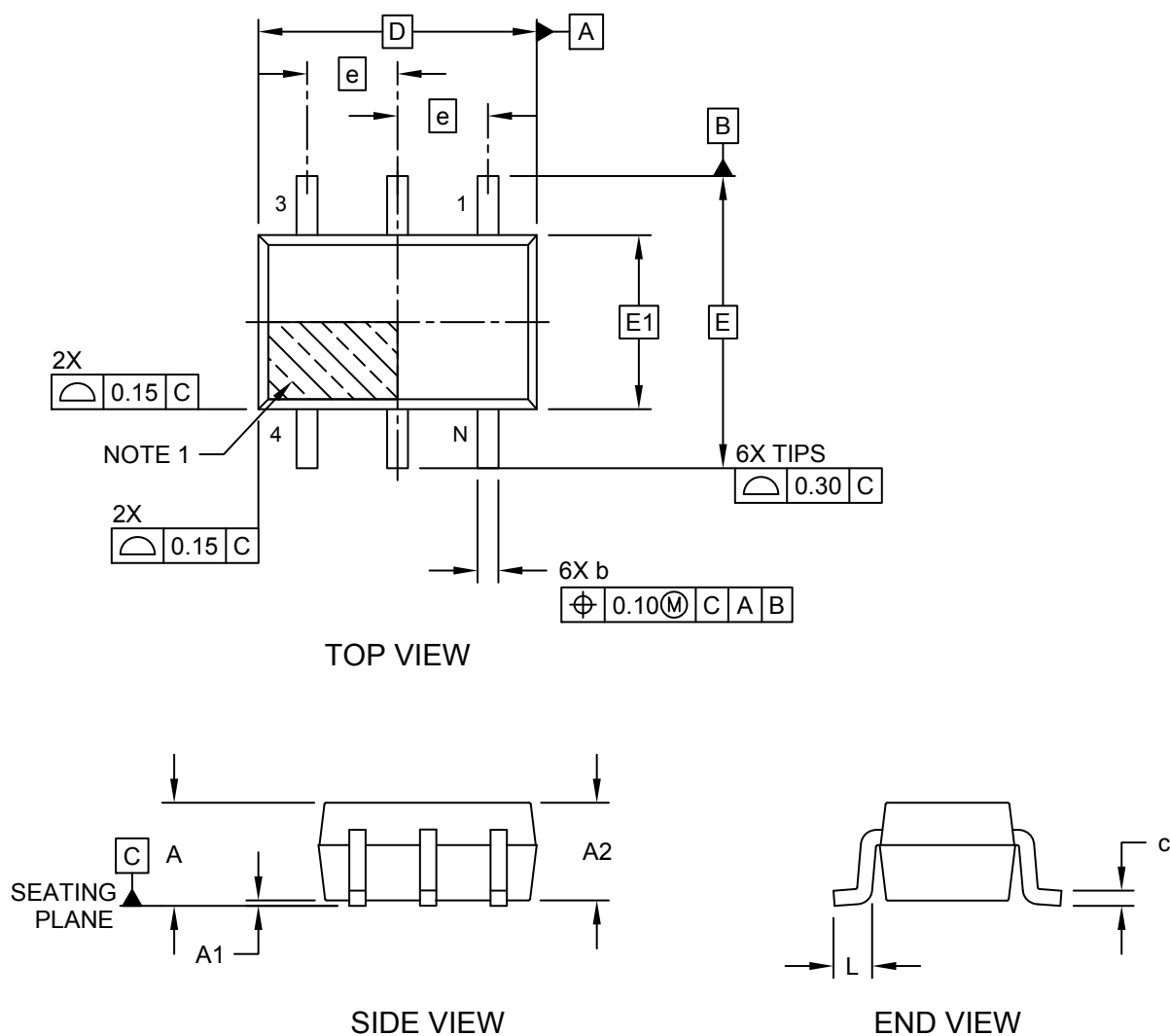



---



---

## Package Outlines and Dimensions

---



---

### 6-Lead Plastic Small Outline Transistor (LT) [SC70]

**Note:** For the most current package drawings, please see the Microchip Packaging Specification located at <http://www.microchip.com/packaging>

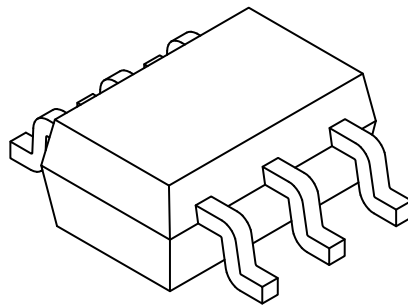

Dimension Limits	Units	MILLIMETERS		
		MIN	NOM	MAX
Number of Pins	N	6		
Pitch	e	0.65 BSC		
Overall Height	A	0.80	-	1.10
Standoff	A1	0.00	-	0.10
Molded Package Thickness	A2	0.80	0.90	1.00
Overall Length	D	2.00 BSC		
Exposed Pad Length	D2	2.50	2.60	2.70
Overall Width	E	2.10 BSC		
Exposed Pad Width	E1	1.25 BSC		
Terminal Width	b	0.15	-	0.30
Terminal Length	L	0.10	0.20	0.46
Lead Thickness	c	0.08	-	0.22

**Notes:**

1. Pin 1 visual index feature may vary, but must be located within the hatched area.
2. Dimensions D and E1 do not include mold flash or protrusions. Mold flash or protrusions shall not exceed 0.15mm per side.
3. Dimensioning and tolerancing per ASME Y14.5M

BSC: Basic Dimension. Theoretically exact value shown without tolerances.

REF: Reference Dimension, usually without tolerance, for information purposes only.

**Footprint Outlines and Dimensions**

**6-Lead Plastic Small Outline Transistor (LT) [SC70]**

**Note:** For the most current package drawings, please see the Microchip Packaging Specification located at <http://www.microchip.com/packaging>

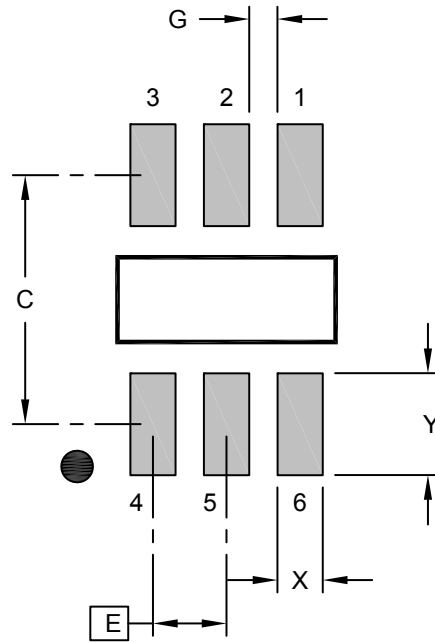

**RECOMMENDED LAND PATTERN**

Dimension Limits	Units	MILLIMETERS		
		MIN	NOM	MAX
Contact Pitch	E	0.65 BSC		
Contact Pad Spacing	C		2.20	
Contact Pad Width (X6)	X			0.40
Contact Pad Length (X6)	Y			0.90
Distance Between Pads	G	0.25		

**Notes:**

- Dimensioning and tolerancing per ASME Y14.5M  
BSC: Basic Dimension. Theoretically exact value shown without tolerances.

---

---

**Package Outlines and Dimensions**

---

---

**SOT-23**

## Package Outlines and Dimensions

### 3-Lead Plastic Small Outline Transistor (NB) [SOT-23]

**Note:** For the most current package drawings, please see the Microchip Packaging Specification located at <http://www.microchip.com/packaging>

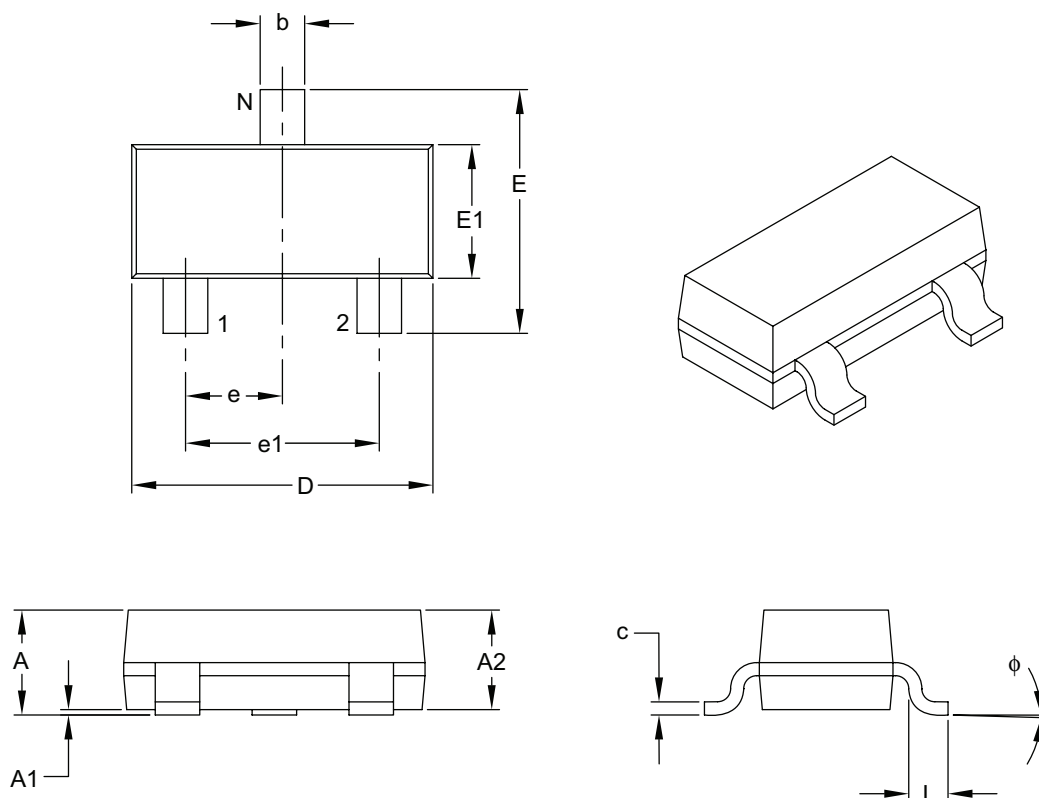

Dimension Limits	Units	MILLIMETERS		
		MIN	NOM	MAX
Number of Pins	N	3		
Lead Pitch	e	0.95 BSC		
Outside Lead Pitch	e1	1.90 BSC		
Overall Height	A	0.89	–	1.12
Molded Package Thickness	A2	0.79	0.95	1.02
Standoff	A1	0.01	–	0.10
Overall Width	E	2.10	–	2.64
Molded Package Width	E1	1.16	1.30	1.40
Overall Length	D	2.67	2.90	3.05
Foot Length	L	0.13	0.50	0.60
Foot Angle	$\phi$	0°	–	10°
Lead Thickness	c	0.08	–	0.20
Lead Width	b	0.30	–	0.54

**Notes:**

- Dimensions D and E1 do not include mold flash or protrusions. Mold flash or protrusions shall not exceed 0.25 mm per side.
- Dimensioning and tolerancing per ASME Y14.5M.

BSC: Basic Dimension. Theoretically exact value shown without tolerances.

---



---

## Footprint Outlines and Dimensions

---



---

### 3-Lead Plastic Small Outline Transistor (NB) [SOT-23]

**Note:** For the most current package drawings, please see the Microchip Packaging Specification located at <http://www.microchip.com/packaging>

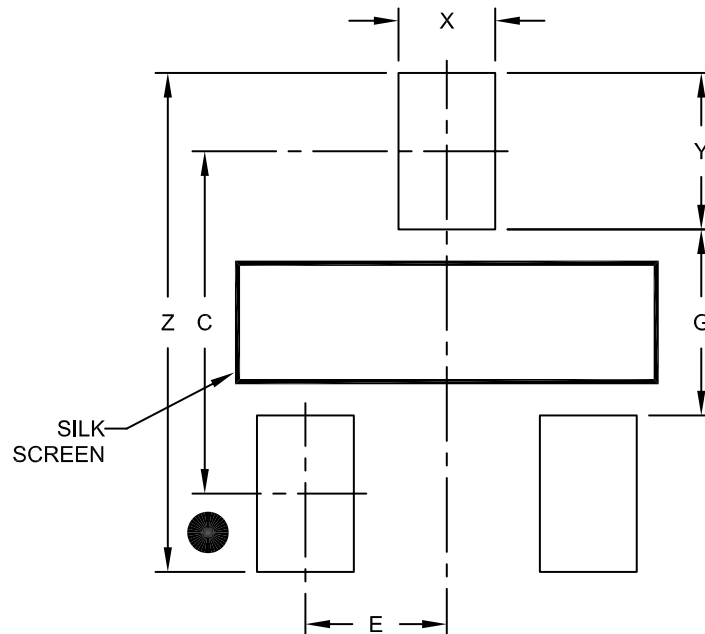

RECOMMENDED LAND PATTERN

Dimension Limits	Units	MILLIMETERS		
		MIN	NOM	MAX
Contact Pitch	E	0.95 BSC		
Contact Pad Spacing	C		2.30	
Contact Pad Width (X3)	X			0.65
Contact Pad Length (X3)	Y			1.05
Distance Between Pads	G	1.25		
Overall Width	Z			3.35

**Notes:**

1. Dimensioning and tolerancing per ASME Y14.5M

BSC: Basic Dimension. Theoretically exact value shown without tolerances.

Microchip Technology Drawing No. C04-2104A

**Package Outlines and Dimensions**

**3-Lead Plastic Small Outline Transistor (TT) [SOT-23]**

**Note:** For the most current package drawings, please see the Microchip Packaging Specification located at <http://www.microchip.com/packaging>

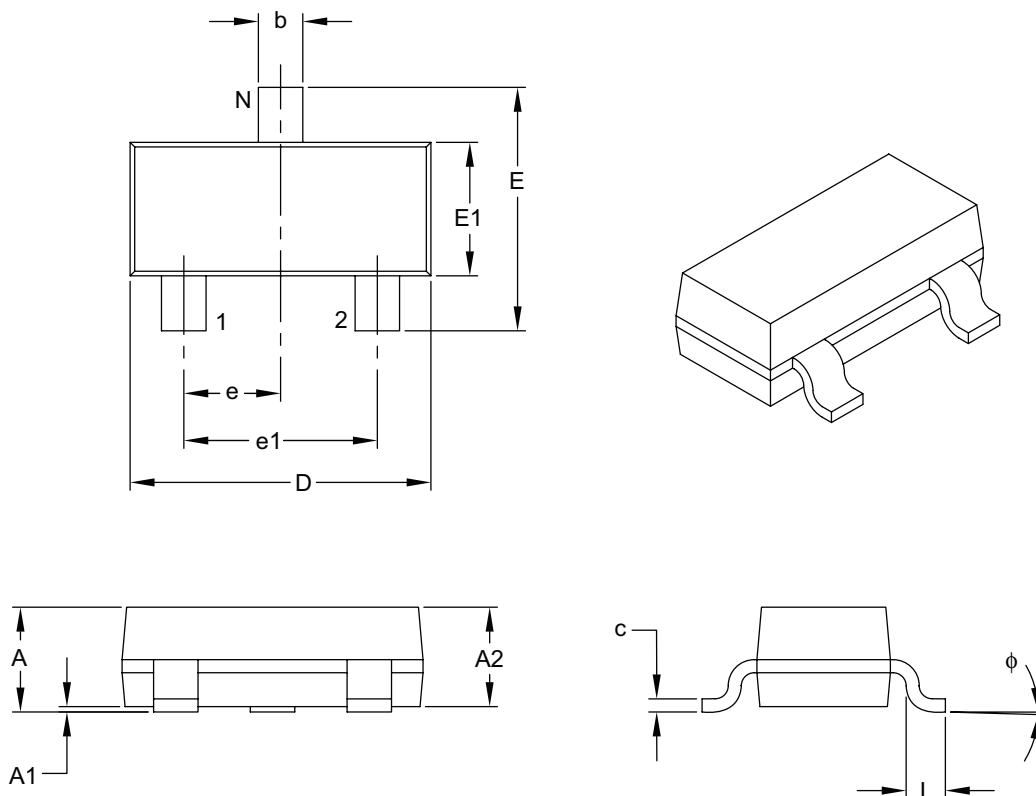

Dimension Limits	Units	MILLIMETERS		
		MIN	NOM	MAX
Number of Pins	N	3		
Lead Pitch	e	0.95 BSC		
Outside Lead Pitch	e1	1.90 BSC		
Overall Height	A	0.89	–	1.12
Molded Package Thickness	A2	0.79	0.95	1.02
Standoff	A1	0.01	–	0.10
Overall Width	E	2.10	–	2.64
Molded Package Width	E1	1.16	1.30	1.40
Overall Length	D	2.67	2.90	3.05
Foot Length	L	0.13	0.50	0.60
Foot Angle	φ	0°	–	10°
Lead Thickness	c	0.08	–	0.20
Lead Width	b	0.30	–	0.54

**Notes:**

- Dimensions D and E1 do not include mold flash or protrusions. Mold flash or protrusions shall not exceed 0.25 mm per side.
- Dimensioning and tolerancing per ASME Y14.5M.  
BSC: Basic Dimension. Theoretically exact value shown without tolerances.

---



---

## Footprint Outlines and Dimensions

---



---

### 3-Lead Plastic Small Outline Transistor (TT) [SOT-23]

**Note:** For the most current package drawings, please see the Microchip Packaging Specification located at <http://www.microchip.com/packaging>

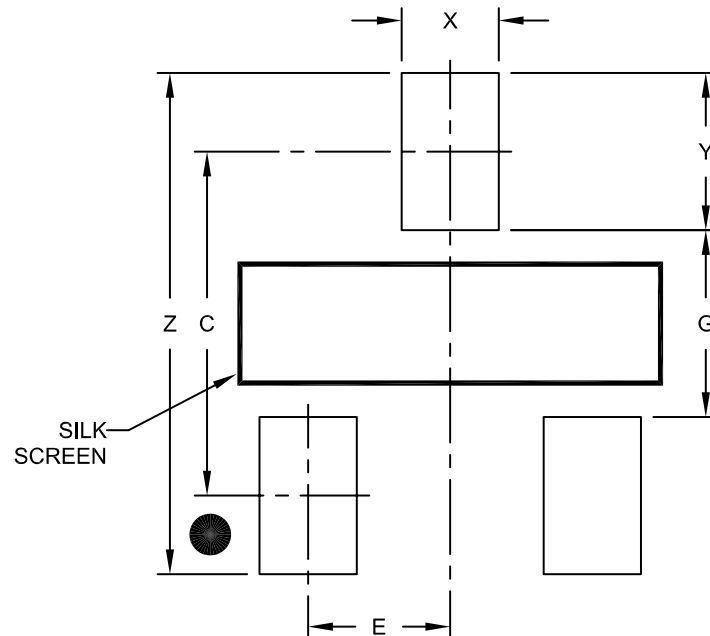

**RECOMMENDED LAND PATTERN**

Dimension Limits	Units	MILLIMETERS		
		MIN	NOM	MAX
Contact Pitch	E	0.95 BSC		
Contact Pad Spacing	C		2.30	
Contact Pad Width (X3)	X			0.65
Contact Pad Length (X3)	Y			1.05
Distance Between Pads	G	1.25		
Overall Width	Z			3.35

**Notes:**

1. Dimensioning and tolerancing per ASME Y14.5M

BSC; Basic Dimension. Theoretically exact value shown without tolerances.

Microchip Technology Drawing No. C04-2104A

**Package Outlines and Dimensions**

**5-Lead Plastic Small Outline Transistor (CT) [SOT23]**

**Note:** For the most current package drawings, please see the Microchip Packaging Specification located at <http://www.microchip.com/packaging>

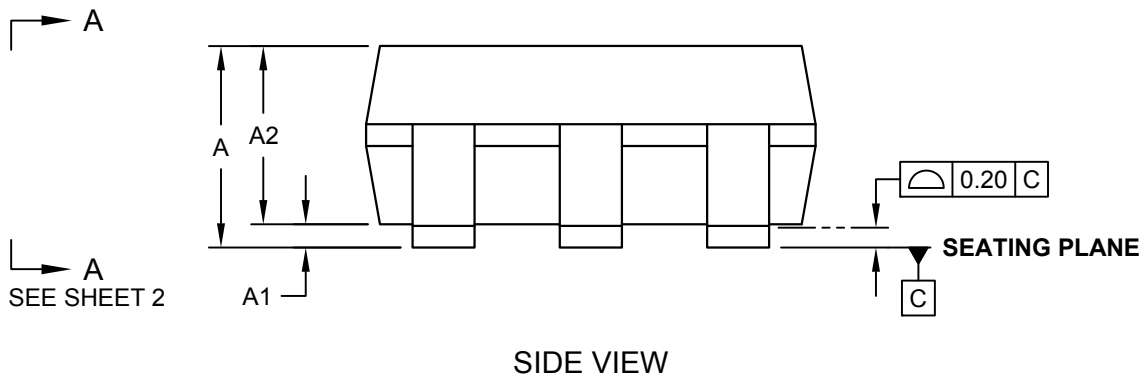
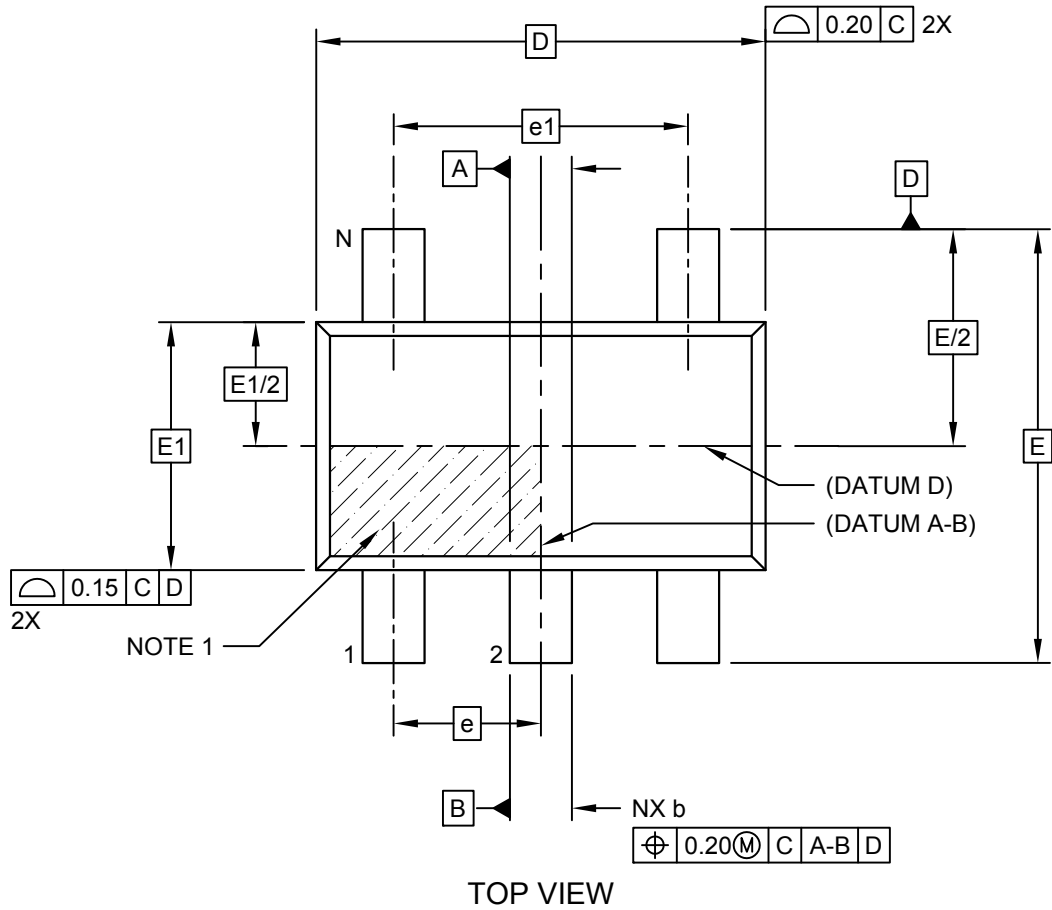



---



---

## Package Outlines and Dimensions

---



---

### 5-Lead Plastic Small Outline Transistor (CT) [SOT23]

**Note:** For the most current package drawings, please see the Microchip Packaging Specification located at <http://www.microchip.com/packaging>

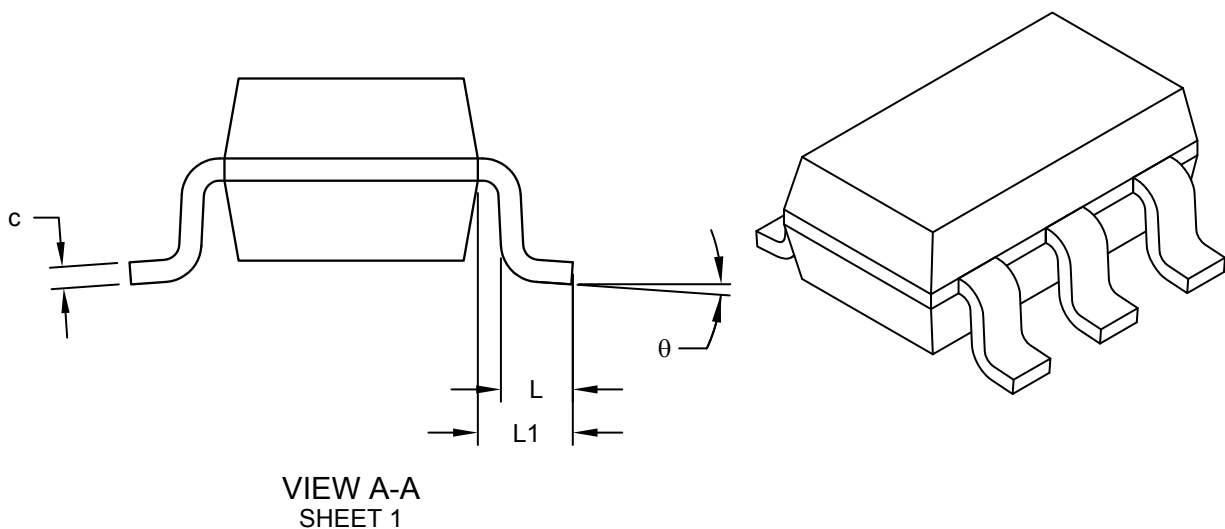

Dimension Limits	Units	MILLIMETERS		
		MIN	NOM	MAX
Number of Pins	N	6		
Pitch	e	0.95 BSC		
Outside lead pitch	e1	1.90 BSC		
Overall Height	A	0.90	-	1.45
Molded Package Thickness	A2	0.89	-	1.30
Standoff	A1	-	-	0.15
Overall Width	E	2.80 BSC		
Molded Package Width	E1	1.60 BSC		
Overall Length	D	2.90 BSC		
Foot Length	L	0.30	-	0.60
Footprint	L1	0.60 REF		
Foot Angle	φ	0°	-	10°
Lead Thickness	c	0.08	-	0.26
Lead Width	b	0.20	-	0.51

**Notes:**

1. Dimensions D and E1 do not include mold flash or protrusions. Mold flash or protrusions shall not exceed 0.25mm per side.
2. Dimensioning and tolerancing per ASME Y14.5M  
 BSC: Basic Dimension. Theoretically exact value shown without tolerances.  
 REF: Reference Dimension, usually without tolerance, for information purposes only.

**Footprint Outlines and Dimensions**

**5-Lead Plastic Small Outline Transistor (CT) [SOT23]**

**Note:** For the most current package drawings, please see the Microchip Packaging Specification located at <http://www.microchip.com/packaging>

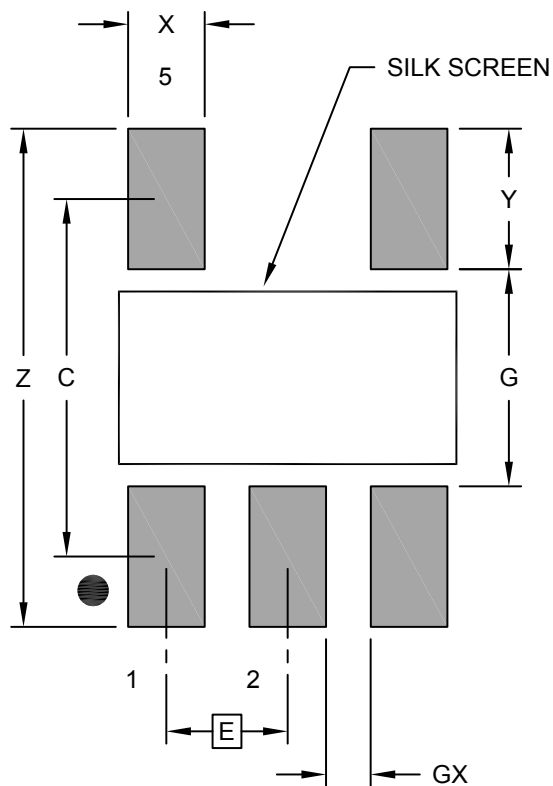

**RECOMMENDED LAND PATTERN**

Dimension Limits	Units	MILLIMETERS		
		MIN	NOM	MAX
Contact Pitch	E	0.95 BSC		
Contact Pad Spacing	C		2.80	
Contact Pad Width (X5)	X			0.60
Contact Pad Length (X5)	Y			1.10
Distance Between Pads	G	1.70		
Distance Between Pads	GX	0.35		
Overall Width	Z			3.90

**Notes:**

1. Dimensioning and tolerancing per ASME Y14.5M

BSC: Basic Dimension. Theoretically exact value shown without tolerances.

Microchip Technology Drawing No. C04-2091A [CT]

**Package Outlines and Dimensions**

**5-Lead Plastic Small Outline Transistor (OT) [SOT23]**

**Note:** For the most current package drawings, please see the Microchip Packaging Specification located at <http://www.microchip.com/packaging>

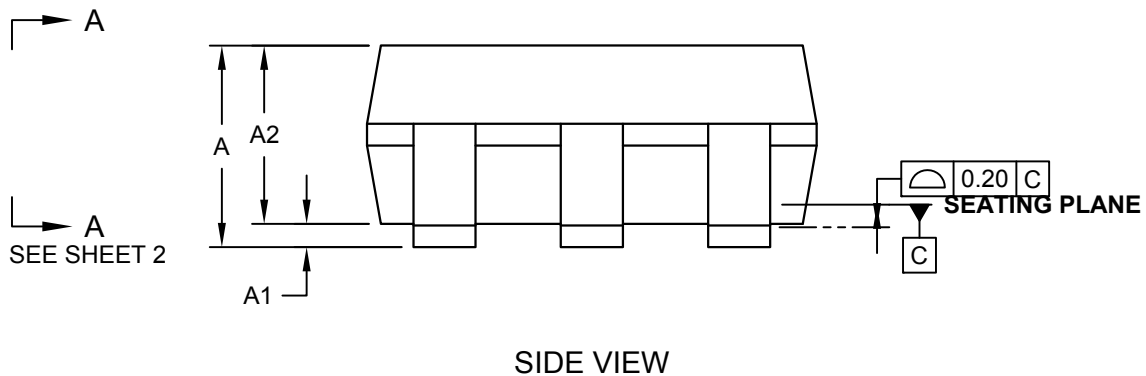
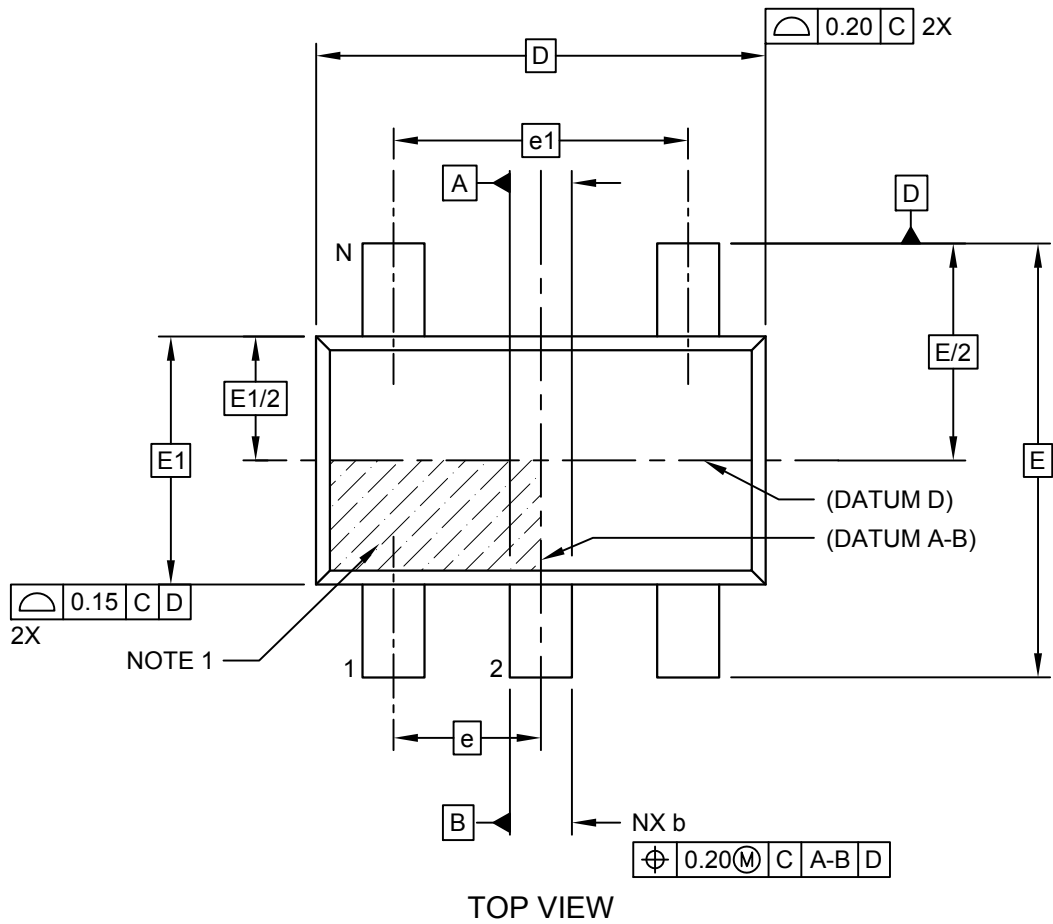

**Package Outlines and Dimensions**

**5-Lead Plastic Small Outline Transistor (OT) [SOT23]**

**Note:** For the most current package drawings, please see the Microchip Packaging Specification located at <http://www.microchip.com/packaging>

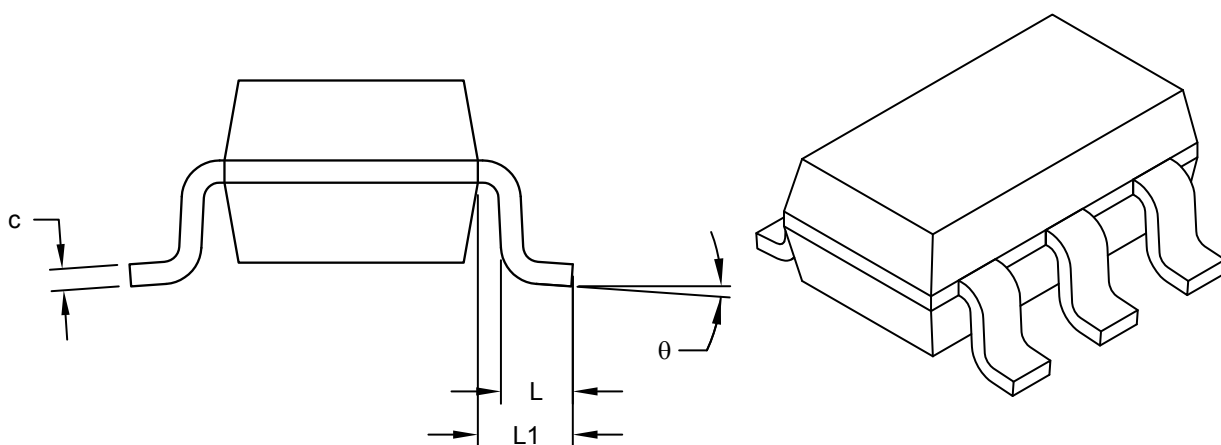

VIEW A-A  
SHEET 1

Dimension Limits	Units	MILLIMETERS		
		MIN	NOM	MAX
Number of Pins	N	6		
Pitch	e	0.95 BSC		
Outside lead pitch	e1	1.90 BSC		
Overall Height	A	0.90	-	1.45
Molded Package Thickness	A2	0.89	-	1.30
Standoff	A1	-	-	0.15
Overall Width	E	2.80 BSC		
Molded Package Width	E1	1.60 BSC		
Overall Length	D	2.90 BSC		
Foot Length	L	0.30	-	0.60
Footprint	L1	0.60 REF		
Foot Angle	φ	0°	-	10°
Lead Thickness	c	0.08	-	0.26
Lead Width	b	0.20	-	0.51

**Notes:**

- Dimensions D and E1 do not include mold flash or protrusions. Mold flash or protrusions shall not exceed 0.25mm per side.
- Dimensioning and tolerancing per ASME Y14.5M  
 BSC: Basic Dimension. Theoretically exact value shown without tolerances.  
 REF: Reference Dimension, usually without tolerance, for information purposes only.

---



---

## Footprint Outlines and Dimensions

---



---

### 5-Lead Plastic Small Outline Transistor (OT) [SOT23]

**Note:** For the most current package drawings, please see the Microchip Packaging Specification located at <http://www.microchip.com/packaging>

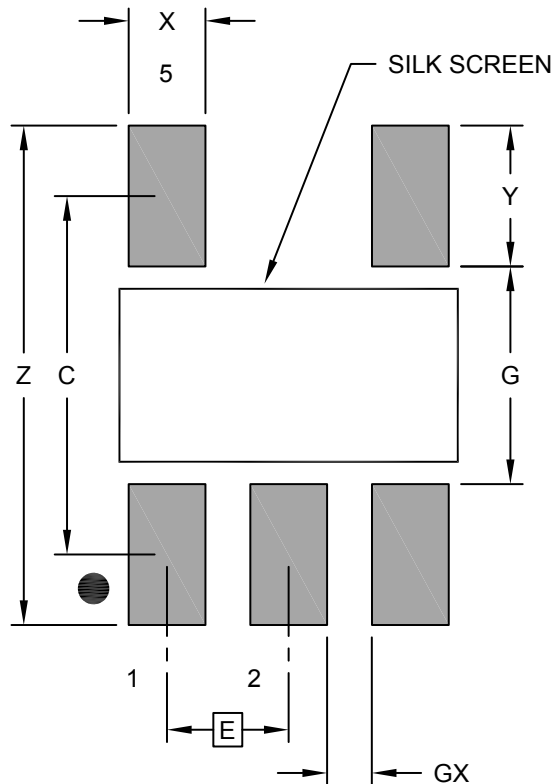

**RECOMMENDED LAND PATTERN**

Dimension Limits	Units	MILLIMETERS		
		MIN	NOM	MAX
Contact Pitch	E		0.95 BSC	
Contact Pad Spacing	C		2.80	
Contact Pad Width (X5)	X			0.60
Contact Pad Length (X5)	Y			1.10
Distance Between Pads	G	1.70		
Distance Between Pads	GX	0.35		
Overall Width	Z			3.90

**Notes:**

1. Dimensioning and tolerancing per ASME Y14.5M

BSC: Basic Dimension. Theoretically exact value shown without tolerances.

Microchip Technology Drawing No. C04-2091A [OT]

**Package Outlines and Dimensions**

**6-Lead Plastic Small Outline Transistor (CH, CHY) [SOT-23]**

**Note:** For the most current package drawings, please see the Microchip Packaging Specification located at <http://www.microchip.com/packaging>

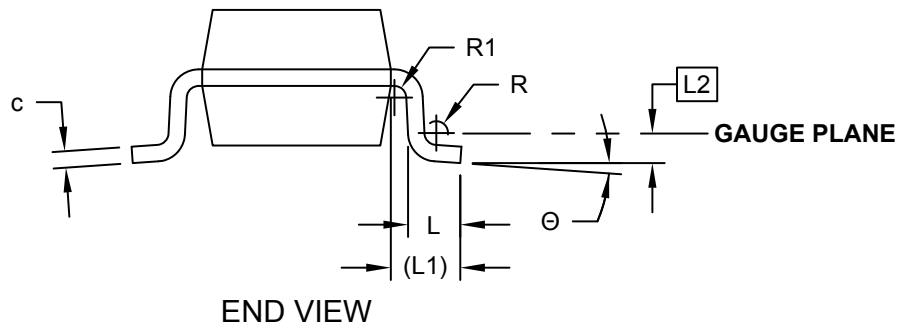
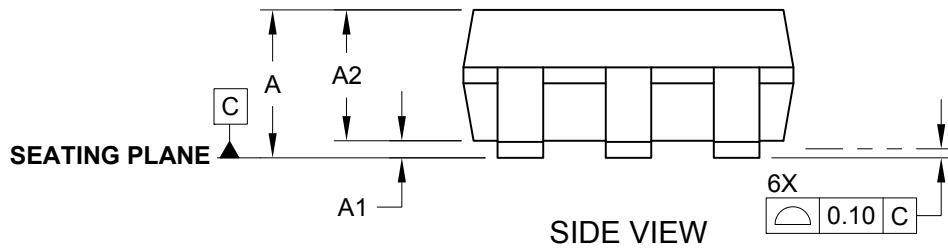
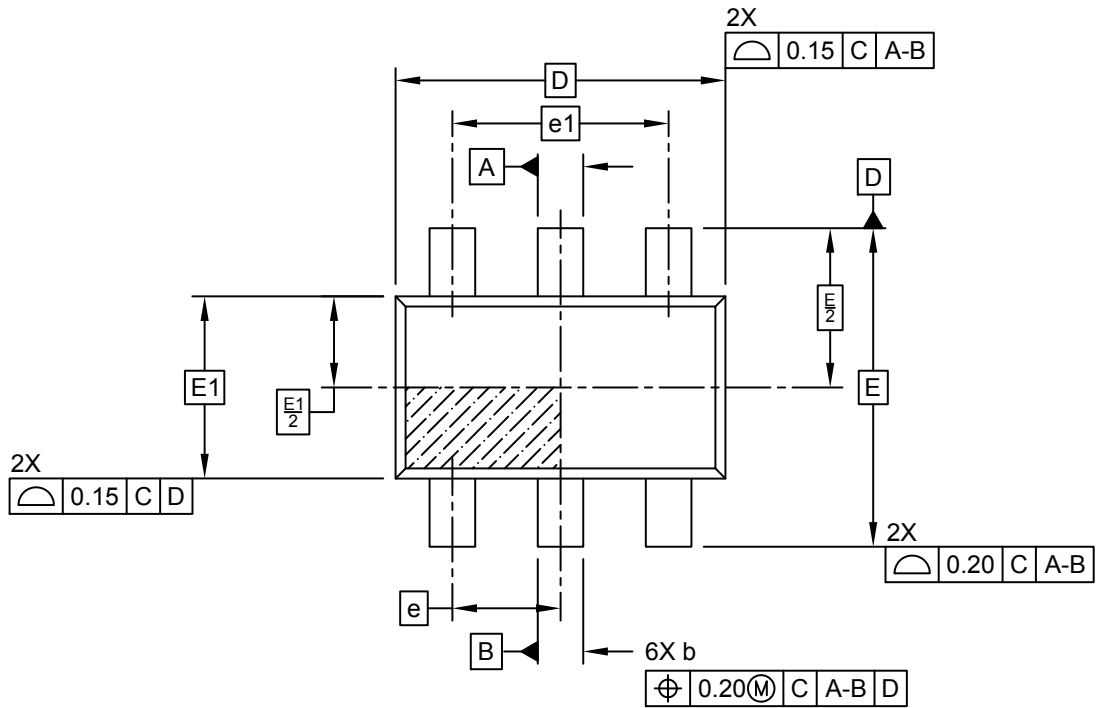

---



---

## Package Outlines and Dimensions

---



---

### 6-Lead Plastic Small Outline Transistor (CH, CHY) [SOT-23]

**Note:** For the most current package drawings, please see the Microchip Packaging Specification located at <http://www.microchip.com/packaging>

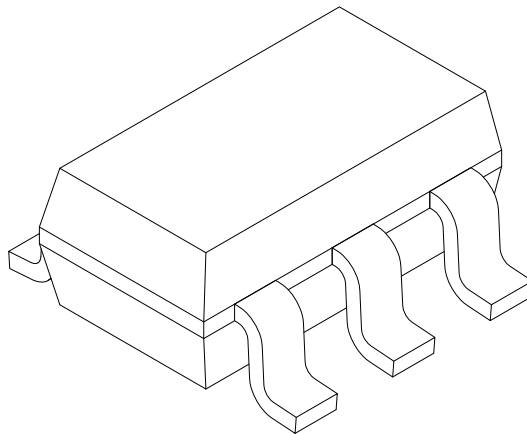

Dimension Limits	Units	MILLIMETERS		
		MIN	NOM	MAX
Number of Leads	N	6		
Pitch	e	0.95 BSC		
Outside lead pitch	e1	1.90 BSC		
Overall Height	A	0.90	-	1.45
Molded Package Thickness	A2	0.89	1.15	1.30
Standoff	A1	0.00	-	0.15
Overall Width	E	2.80 BSC		
Molded Package Width	E1	1.60 BSC		
Overall Length	D	2.90 BSC		
Foot Length	L	0.30	0.45	0.60
Footprint	L1	0.60 REF		
Seating Plane to Gauge Plane	L1	0.25 BSC		
Foot Angle	$\phi$	0°	-	10°
Lead Thickness	c	0.08	-	0.26
Lead Width	b	0.20	-	0.51

**Notes:**

1. Dimensions D and E1 do not include mold flash or protrusions. Mold flash or protrusions shall not exceed 0.25mm per side.
2. Dimensioning and tolerancing per ASME Y14.5M
  - BSC: Basic Dimension. Theoretically exact value shown without tolerances.
  - REF: Reference Dimension, usually without tolerance, for information purposes only.

**Footprint Outlines and Dimensions**

**6-Lead Plastic Small Outline Transistor (CH, CHY) [SOT-23]**

**Note:** For the most current package drawings, please see the Microchip Packaging Specification located at <http://www.microchip.com/packaging>

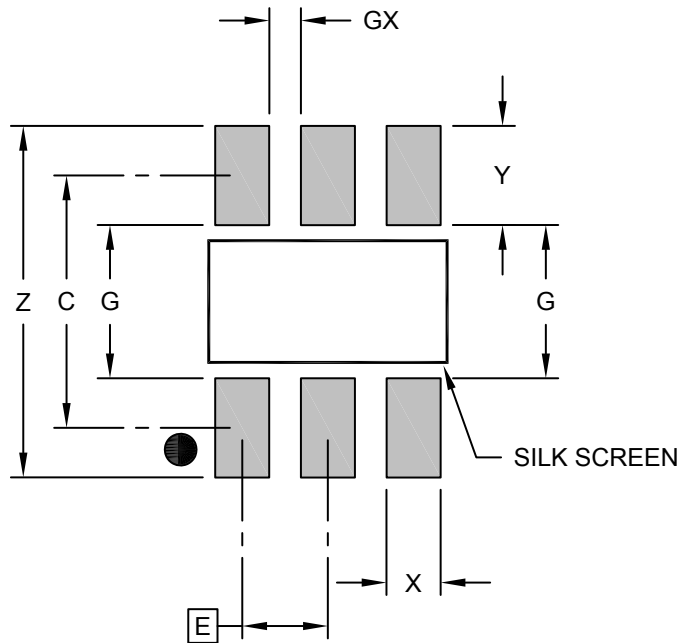

**RECOMMENDED LAND PATTERN**

Dimension Limits	Units	MILLIMETERS		
		MIN	NOM	MAX
Contact Pitch	E	0.95 BSC		
Contact Pad Spacing	C		2.80	
Contact Pad Width (X3)	X			0.60
Contact Pad Length (X3)	Y			1.10
Distance Between Pads	G	1.70		
Distance Between Pads	GX	0.35		
Overall Width	Z			3.90

**Notes:**

1. Dimensioning and tolerancing per ASME Y14.5M  
BSC: Basic Dimension. Theoretically exact value shown without tolerances.

Microchip Technology Drawing No. C04-2028B (CH)



**Footprint Outlines and Dimensions**

**6-Lead Plastic Small Outline Transistor (OT, OTY) [SOT-23]**

**Note:** For the most current package drawings, please see the Microchip Packaging Specification located at <http://www.microchip.com/packaging>

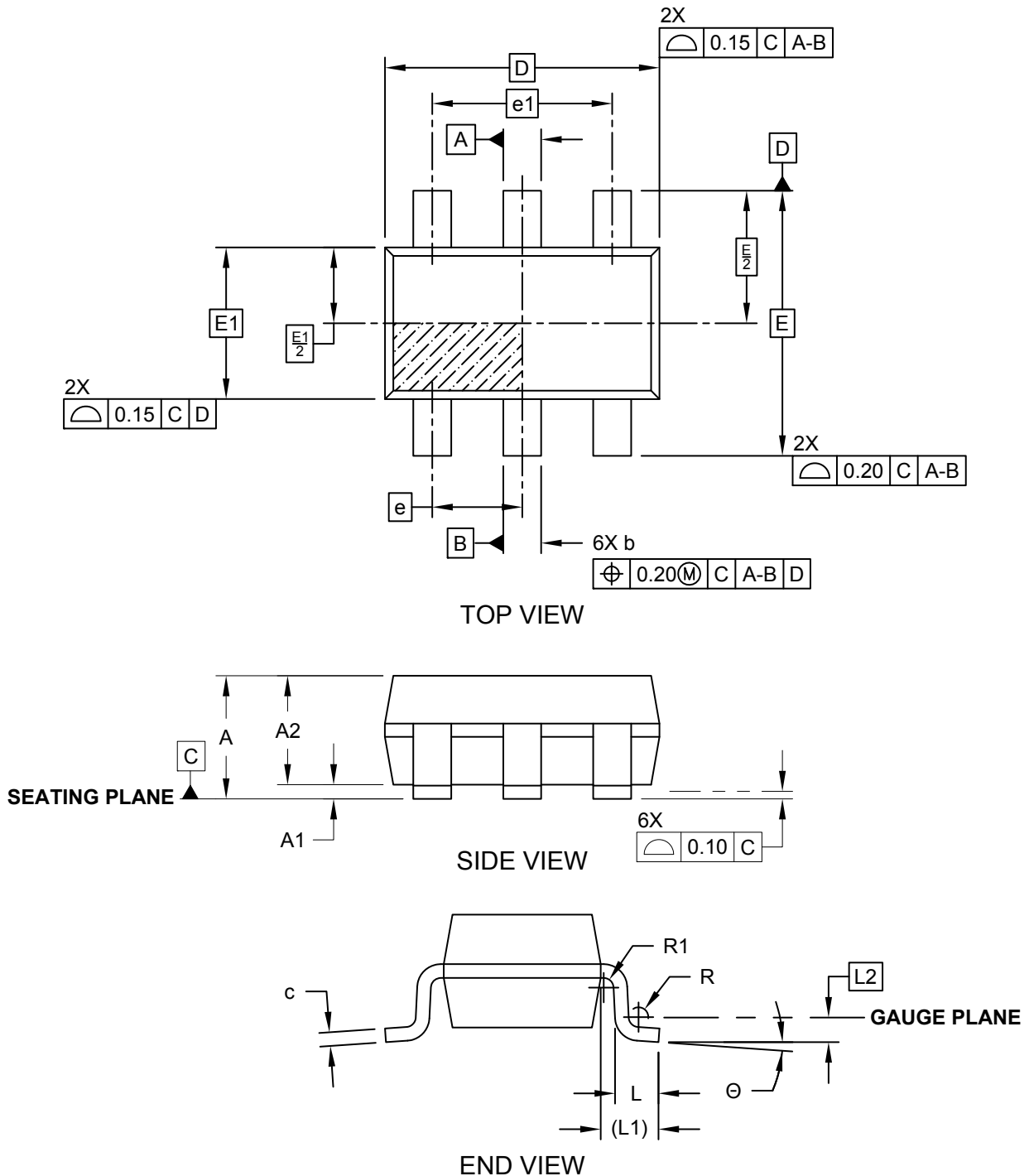

**Package Outlines and Dimensions**

**6-Lead Plastic Small Outline Transistor (OT, OTY) [SOT-23]**

**Note:** For the most current package drawings, please see the Microchip Packaging Specification located at <http://www.microchip.com/packaging>

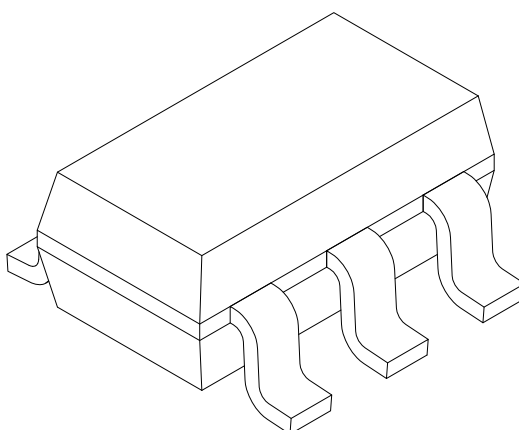

Dimension Limits	Units	MILLIMETERS		
		MIN	NOM	MAX
Number of Leads	N	6		
Pitch	e	0.95 BSC		
Outside lead pitch	e1	1.90 BSC		
Overall Height	A	0.90	-	1.45
Molded Package Thickness	A2	0.89	1.15	1.30
Standoff	A1	0.00	-	0.15
Overall Width	E	2.80 BSC		
Molded Package Width	E1	1.60 BSC		
Overall Length	D	2.90 BSC		
Foot Length	L	0.30	0.45	0.60
Footprint	L1	0.60 REF		
Seating Plane to Gauge Plane	L1	0.25 BSC		
Foot Angle	φ	0°	-	10°
Lead Thickness	c	0.08	-	0.26
Lead Width	b	0.20	-	0.51

**Notes:**

1. Dimensions D and E1 do not include mold flash or protrusions. Mold flash or protrusions shall not exceed 0.25mm per side.
2. Dimensioning and tolerancing per ASME Y14.5M
  - BSC: Basic Dimension. Theoretically exact value shown without tolerances.
  - REF: Reference Dimension, usually without tolerance, for information purposes only.

---



---

## Footprint Outlines and Dimensions

---



---

### 6-Lead Plastic Small Outline Transistor (OT, OTY) [SOT-23]

**Note:** For the most current package drawings, please see the Microchip Packaging Specification located at <http://www.microchip.com/packaging>

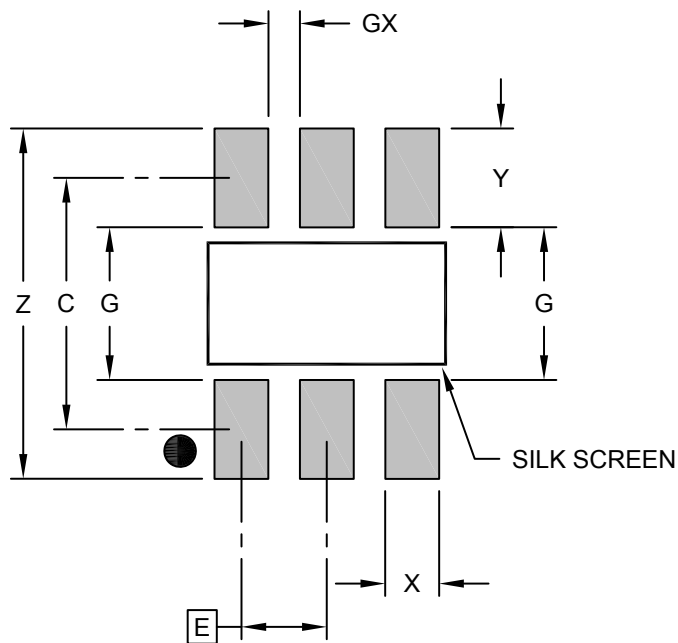

RECOMMENDED LAND PATTERN

Dimension Limits	Units	MILLIMETERS		
		MIN	NOM	MAX
Contact Pitch	E	0.95 BSC		
Contact Pad Spacing	C		2.80	
Contact Pad Width (X3)	X			0.60
Contact Pad Length (X3)	Y			1.10
Distance Between Pads	G	1.70		
Distance Between Pads	GX	0.35		
Overall Width	Z			3.90

**Notes:**

1. Dimensioning and tolerancing per ASME Y14.5M

BSC: Basic Dimension. Theoretically exact value shown without tolerances.

Microchip Technology Drawing No. C04-2028B (OT)



**MICROCHIP**

---

---

**Package Outlines and Dimensions**

---

---

**NOTES:**

---

---

**Package Outlines and Dimensions**

---

---

**SOT-23A**

**Package Outlines and Dimensions**

**3-Lead Plastic Small Outline Transistor (CB) [SOT-23A]**

**Note:** For the most current package drawings, please see the Microchip Packaging Specification located at <http://www.microchip.com/packaging>

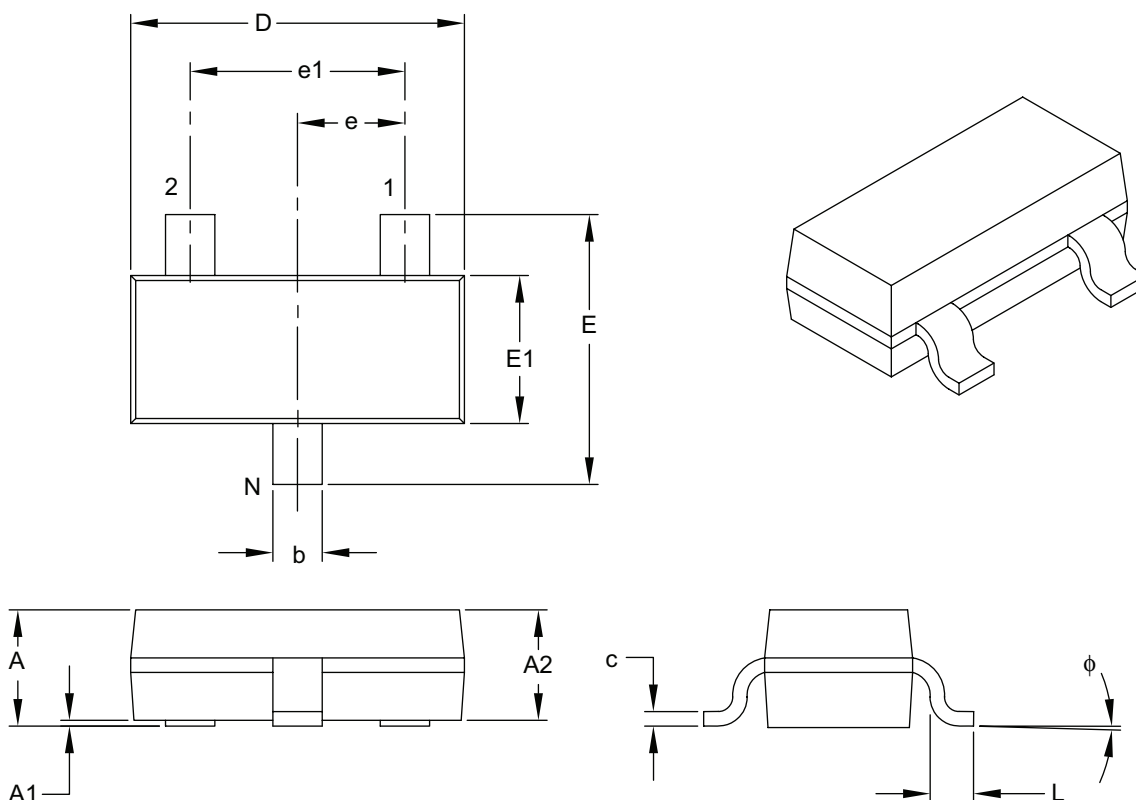

Dimension Limits	Units	MILLIMETERS		
		MIN	NOM	MAX
Number of Pins	N	3		
Lead Pitch	e	0.95 BSC		
Outside Lead Pitch	e1	1.90 BSC		
Overall Height	A	0.89	–	1.45
Molded Package Thickness	A2	0.90	–	1.30
Standoff	A1	0.00	–	0.15
Overall Width	E	2.10	–	3.00
Molded Package Width	E1	1.20	–	1.80
Overall Length	D	2.70	–	3.10
Foot Length	L	0.15	–	0.60
Foot Angle	$\phi$	0°	–	30°
Lead Thickness	c	0.09	–	0.26
Lead Width	b	0.30	–	0.51

**Notes:**

- Dimensions D and E1 do not include mold flash or protrusions. Mold flash or protrusions shall not exceed 0.127 mm per side.
- Dimensioning and tolerancing per ASME Y14.5M.

BSC: Basic Dimension. Theoretically exact value shown without tolerances.

---



---

## Footprint Outlines and Dimensions

---



---

### 3-Lead Plastic Small Outline Transistor (CB) [SOT-23A]

**Note:** For the most current package drawings, please see the Microchip Packaging Specification located at <http://www.microchip.com/packaging>

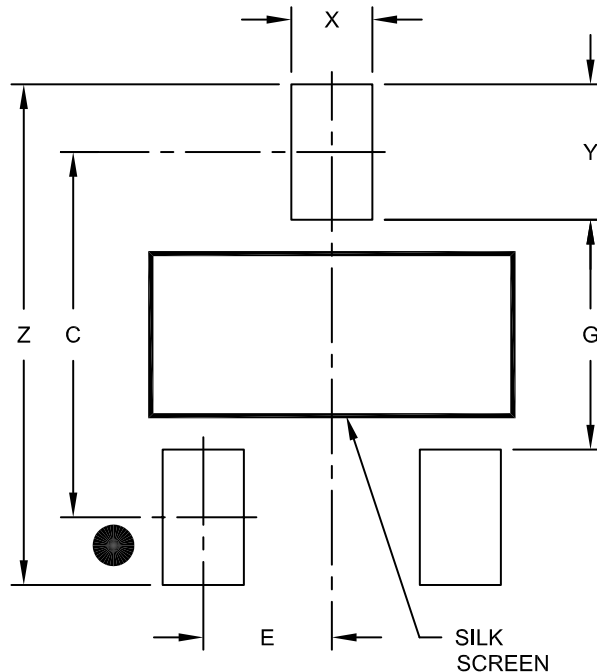

**RECOMMENDED LAND PATTERN**

Dimension Limits	Units	MILLIMETERS		
		MIN	NOM	MAX
Contact Pitch	E	0.95 BSC		
Contact Pad Spacing	C		2.70	
Contact Pad Width (X3)	X			0.60
Contact Pad Length (X3)	Y			1.00
Distance Between Pads	G	1.70		
Overall Width	Z			3.70

**Notes:**

1. Dimensioning and tolerancing per ASME Y14.5M

BSC: Basic Dimension. Theoretically exact value shown without tolerances.

Microchip Technology Drawing No. C04-2130A



**MICROCHIP**

---

---

**Package Outlines and Dimensions**

---

---

NOTES:



---

---

**Package Outlines and Dimensions**

---

---

**SOT-25**

**Package Outlines and Dimensions**

**5L Plastic Small Outline Transistor Package (5A) - [SOT-25]**

**Note:** For the most current package drawings, please see the Microchip Packaging Specification located at <http://www.microchip.com/packaging>

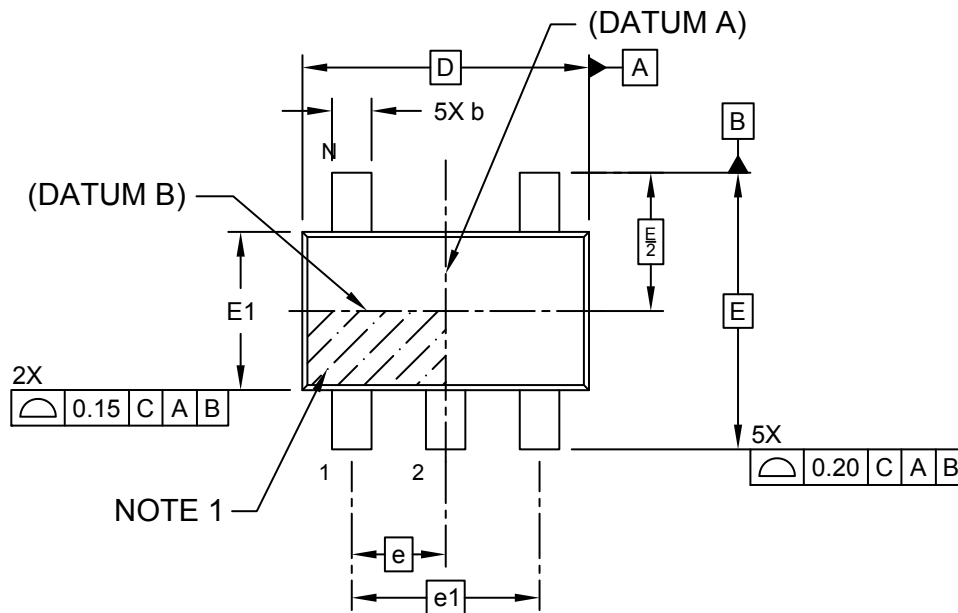

TOP VIEW

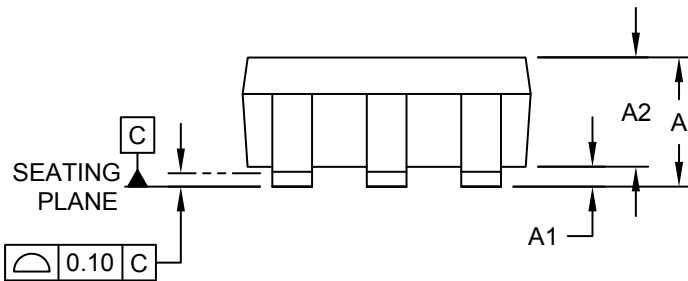

SIDE VIEW

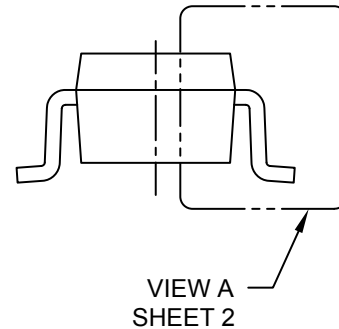

END VIEW

---



---

## Package Outlines and Dimensions

---



---

### 5L Plastic Small Outline Transistor Package (5A) - [SOT-25]

**Note:** For the most current package drawings, please see the Microchip Packaging Specification located at <http://www.microchip.com/packaging>

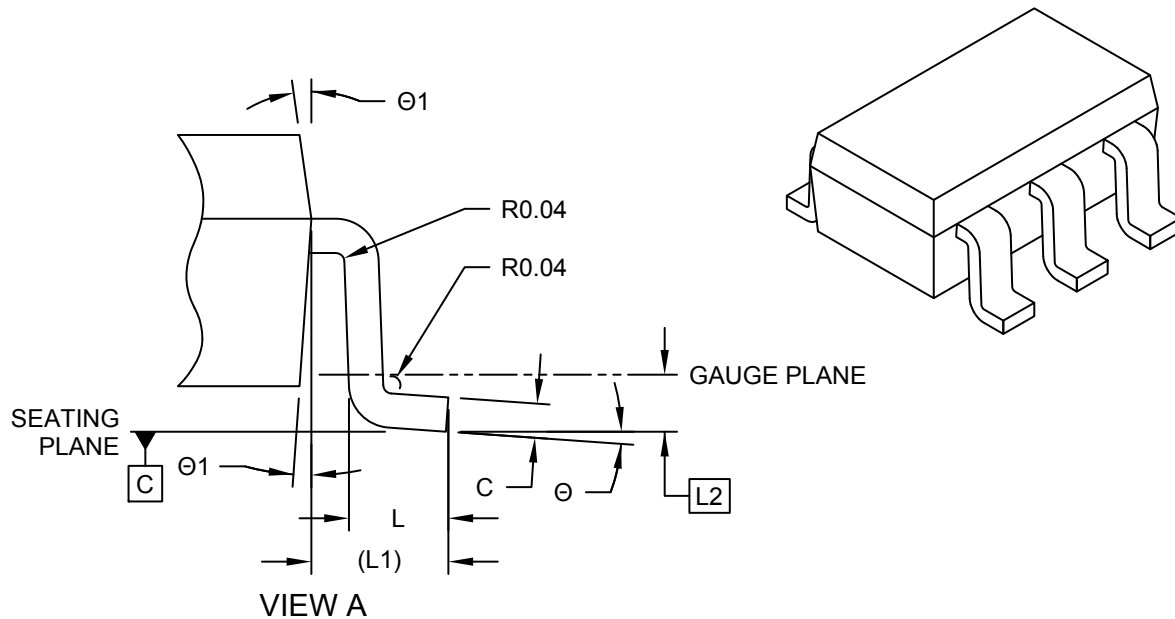

Dimension Limits	Units	MILLIMETERS		
		MIN	NOM	MAX
Number of Pins	N	5		
Pitch	e	0.95 BSC		
Overall Pitch	e1	1.90 BSC		
Overall Height	A	-	-	1.30
Standoff	A1	0.20	-	-
Molded Package Height	A2	1.00	1.10	1.20
Molded Package Length	D	2.90 BSC		
Overall Width	E	2.80 BSC		
Molded Package Width	E1	1.50	1.60	1.80
Foot Length	L	0.20	-	-
Footprint	(L1)	0.61 REF		
Seating Plane to Gauge Plane	L2	0.25 BSC		
Lead Width	b	0.35	0.40	0.50
Lead Thickness	c	0.10	0.15	0.25
Foot Angle	Θ	0°	4°	8°
Mold Draft Angle	Θ1	5°	10°	15°

**Notes:**

1. Pin 1 visual index feature may vary, but must be located within the hatched area if used.
2. Dimensioning and tolerancing per ASME Y14.5M
  - BSC: Basic Dimension. Theoretically exact value shown without tolerances.
  - REF: Reference Dimension, usually without tolerance, for information purposes only.

---



---

**Footprint Outlines and Dimensions**

---



---

**5L Plastic Small Outline Transistor Package (5A) - [SOT-25]**

**Note:** For the most current package drawings, please see the Microchip Packaging Specification located at <http://www.microchip.com/packaging>

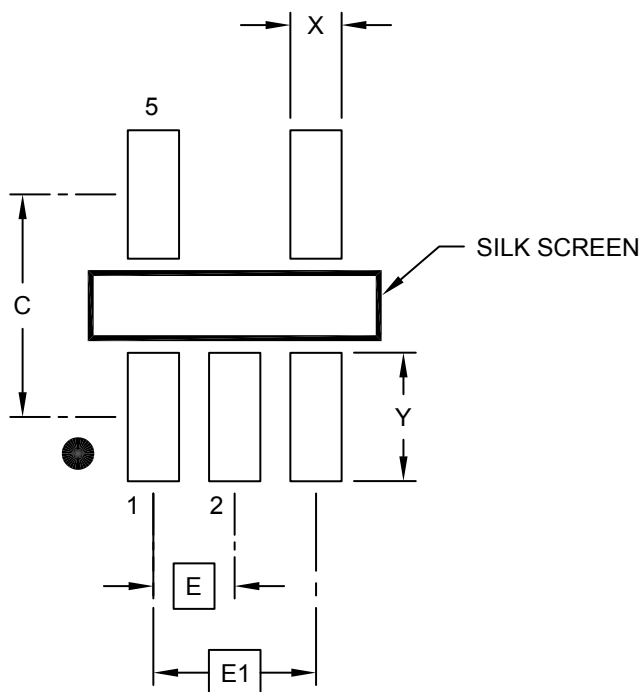

**RECOMMENDED LAND PATTERN**

		Units	MILLIMETERS		
Dimension Limits			MIN	NOM	MAX
Contact Pitch	E		0.95 BSC		
Overall Pitch	E1		1.90 BSC		
Contact Width	X			0.60	
Contact Pad Length	Y			1.05	
Contact Pad Spacing	C			2.60	

**Notes:**

1. Dimensioning and tolerancing per ASME Y14.5M  
BSC: Basic Dimension. Theoretically exact value shown without tolerances.

---

---

**Package Outlines and Dimensions**

---

---

**SOT-89**

**Package Outlines and Dimensions**

**3-Lead Plastic Small Outline Transistor (MB) - [SOT-89]**

**Note:** For the most current package drawings, please see the Microchip Packaging Specification located at <http://www.microchip.com/packaging>

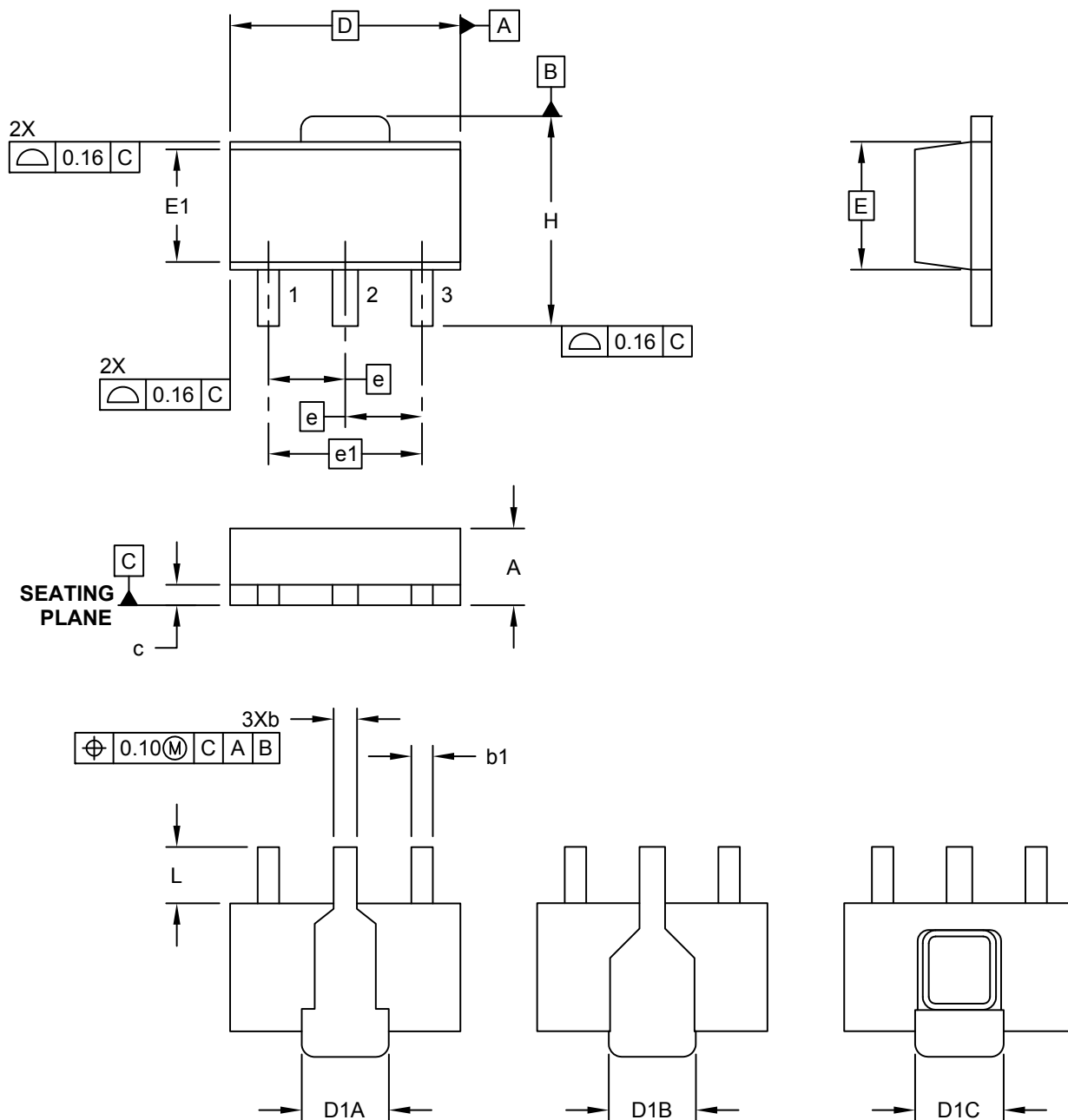

OPTIONAL BACKSIDE PATTERNS —  
PARTS MAY BE SUPPLIED WITH  
ANY PATTERN SHOWN

---



---

## Package Outlines and Dimensions

---



---

### 3-Lead Plastic Small Outline Transistor (MB) - [SOT-89]

**Note:** For the most current package drawings, please see the Microchip Packaging Specification located at <http://www.microchip.com/packaging>

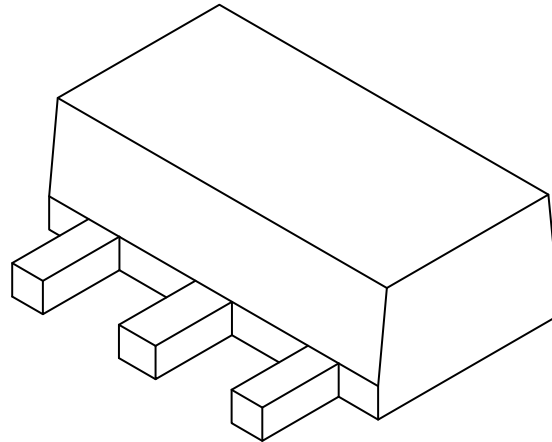

Dimension Limits	Units	MILLIMETERS		
		MIN	NOM	MAX
Number of Leads	N	3		
Pitch	e	1.50 BSC		
Outside Lead Pitch	e1	3.00 BSC		
Overall Height	A	1.40	1.50	1.60
Overall Width	H	3.94	4.10	4.25
Molded Package Width at Base	E	2.50 BSC		
Molded Package Width at Top	E1	2.13	2.20	2.29
Overall Length	D	4.50 BSC		
Tab Length (Option A)	D1A	1.63	1.73	1.83
Tab Length (Option B)	D1B	1.40	1.60	1.75
Tab Length (Option C)	D1C	1.62	1.73	1.83
Foot Length	L	0.79	1.10	1.20
Lead Thickness	c	0.35	0.40	0.44
Lead 2 Width	b	0.41	0.50	0.56
Leads 1 & 3 Width	b1	0.36	0.42	0.48

**Notes:**

1. Dimensions D and E do not include mold flash or protrusions. Mold flash or protrusions shall not exceed 0.127mm per side.
2. Dimensioning and tolerancing per ASME Y14.5M  
 BSC: Basic Dimension. Theoretically exact value shown without tolerances.

**Footprint Outlines and Dimensions**

**3-Lead Plastic Small Outline Transistor (MB) - [SOT-89]**

**Note:** For the most current package drawings, please see the Microchip Packaging Specification located at <http://www.microchip.com/packaging>

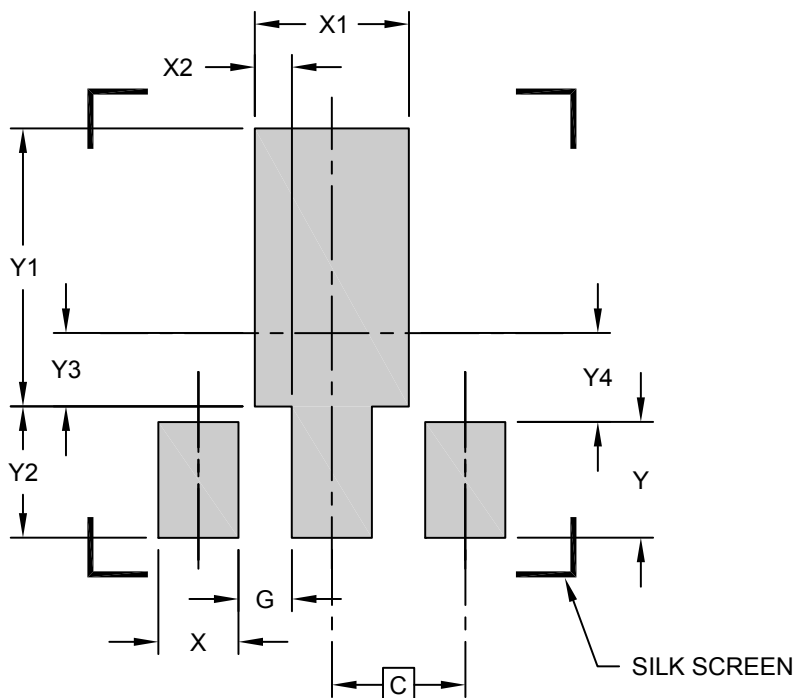

**RECOMMENDED LAND PATTERN**

Units	MILLIMETERS		
	MIN	NOM	MAX
C	1.50 (BSC)		
X (3 PLACES)		0.900	
X1		1.733	
X2 (2 PLACES)		0.416	
G (2 PLACES)		0.600	
Y (2 PLACES)		1.300	
Y1		3.125	
Y2		1.475	
Y3		0.825	
Y4		1.000	

**Notes:**

1. Dimensioning and tolerancing per ASME Y14.5M

BSC: Basic Dimension. Theoretically exact value shown without tolerances.



---



---

## Package Outlines and Dimensions

---



---

### 5-Lead Plastic Small Outline Transistor Header (MT) [SOT-89]

**Note:** For the most current package drawings, please see the Microchip Packaging Specification located at <http://www.microchip.com/packaging>

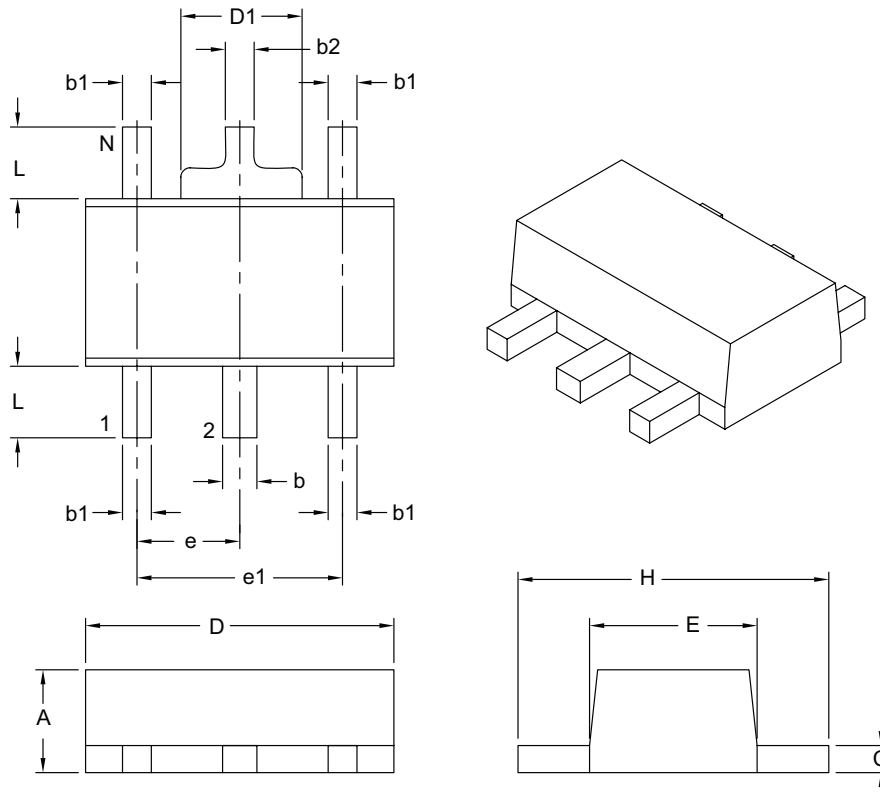

	Units	MILLIMETERS	
		MIN	MAX
Number of Leads	N	5	
Lead Pitch	e	1.50 BSC	
Outside Lead Pitch	e1	3.00 BSC	
Overall Height	A	1.40	1.60
Overall Width	H	3.94	4.50
Molded Package Width	E	2.29	2.60
Overall Length	D	4.40	4.60
Tab Width	D1	1.40	1.83
Foot Length	L	0.80	1.20
Lead Thickness	c	0.35	0.44
Lead 2 Width	b	0.41	0.56
Leads 1, 3, 4 & 5 Width	b1	0.36	0.48
Tab Lead Width	b2	0.32	0.48

**Notes:**

- Dimensions D and E do not include mold flash or protrusions. Mold flash or protrusions shall not exceed 0.127 mm per side.
- Dimensioning and tolerancing per ASME Y14.5M.

BSC: Basic Dimension. Theoretically exact value shown without tolerances.

Microchip Technology Drawing C04-030B

**Footprint Outlines and Dimensions**

**5-Lead Plastic Small Outline Transistor Header (MT) [SOT-89]**

**Note:** For the most current package drawings, please see the Microchip Packaging Specification located at <http://www.microchip.com/packaging>

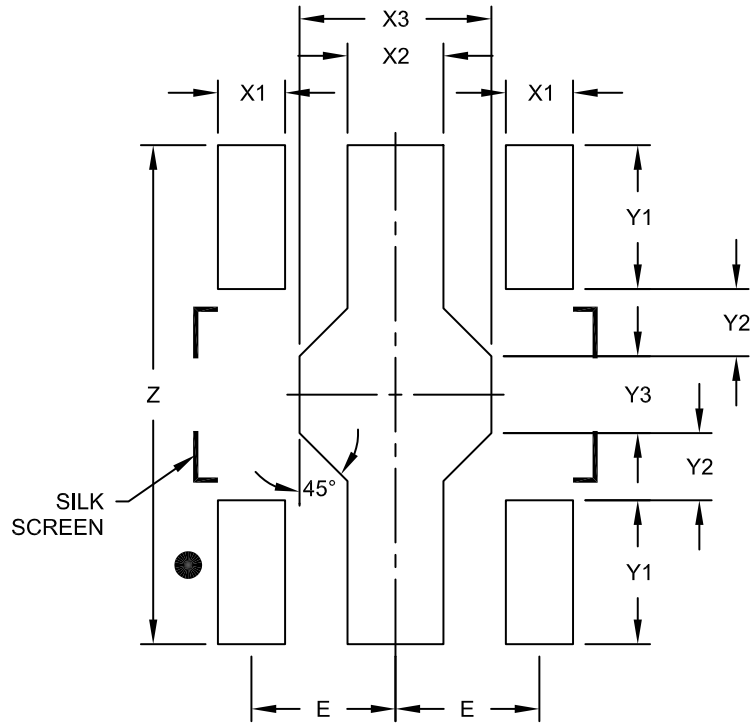

**RECOMMENDED LAND PATTERN**

Dimension Limits	Units	MILLIMETERS		
		MIN	NOM	MAX
Contact Pitch	E	1.50 BSC		
Contact Pad Width (X4)	X1			0.70
Contact Pad Width	X2		1.00	
Contact Pad Width	X3		2.00	
Contact Pad Length (X4)	Y1		1.50	
Contact Pad Length (X2)	Y2		0.70	
Contact Pad Length	Y3		0.80	
Overall Length	Z		5.20	

**Notes:**

1. Dimensioning and tolerancing per ASME Y14.5M

BSC: Basic Dimension. Theoretically exact value shown without tolerances.

Microchip Technology Drawing No. C04-2030C

---

---

**Package Outlines and Dimensions**

---

---

**SOT-143**

## Package Outlines and Dimensions

### 4-Lead Plastic Small Outline Transistor (RC) [SOT-143]

**Note:** For the most current package drawings, please see the Microchip Packaging Specification located at <http://www.microchip.com/packaging>

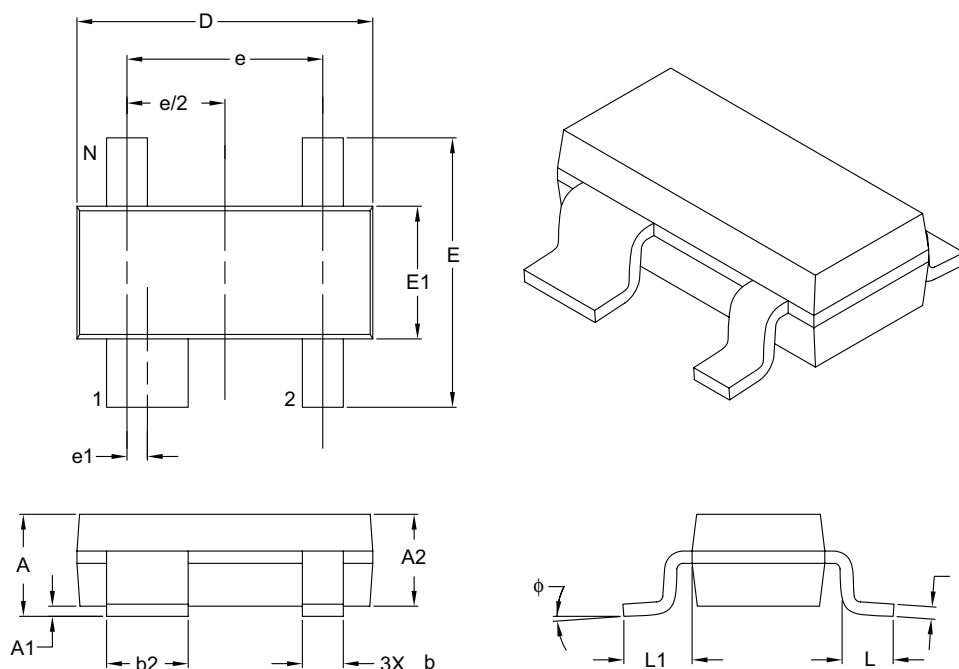

Dimension Limits	Units	MILLIMETERS		
		MIN	NOM	MAX
Number of Pins	N	4		
Pitch	e	1.92 BSC		
Lead 1 Offset	e1	0.20 BSC		
Overall Height	A	0.80	–	1.22
Molded Package Thickness	A2	0.75	0.90	1.07
Standoff §	A1	0.01	–	0.15
Overall Width	E	2.10	–	2.64
Molded Package Width	E1	1.20	1.30	1.40
Overall Length	D	2.67	2.90	3.05
Foot Length	L	0.13	0.50	0.60
Footprint	L1	0.54 REF		
Foot Angle	φ	0°	–	8°
Lead Thickness	c	0.08	–	0.20
Lead 1 Width	b1	0.76	–	0.94
Leads 2, 3 & 4 Width	b	0.30	–	0.54

**Notes:**

- § Significant Characteristic.
- Dimensions D and E1 do not include mold flash or protrusions. Mold flash or protrusions shall not exceed 0.25 mm per side.
- Dimensioning and tolerancing per ASME Y14.5M.

BSC: Basic Dimension. Theoretically exact value shown without tolerances.

REF: Reference Dimension, usually without tolerance, for information purposes only.

---



---

## Footprint Outlines and Dimensions

---



---

### 4-Lead Plastic Small Outline Transistor (RC) [SOT-143]

**Note:** For the most current package drawings, please see the Microchip Packaging Specification located at <http://www.microchip.com/packaging>

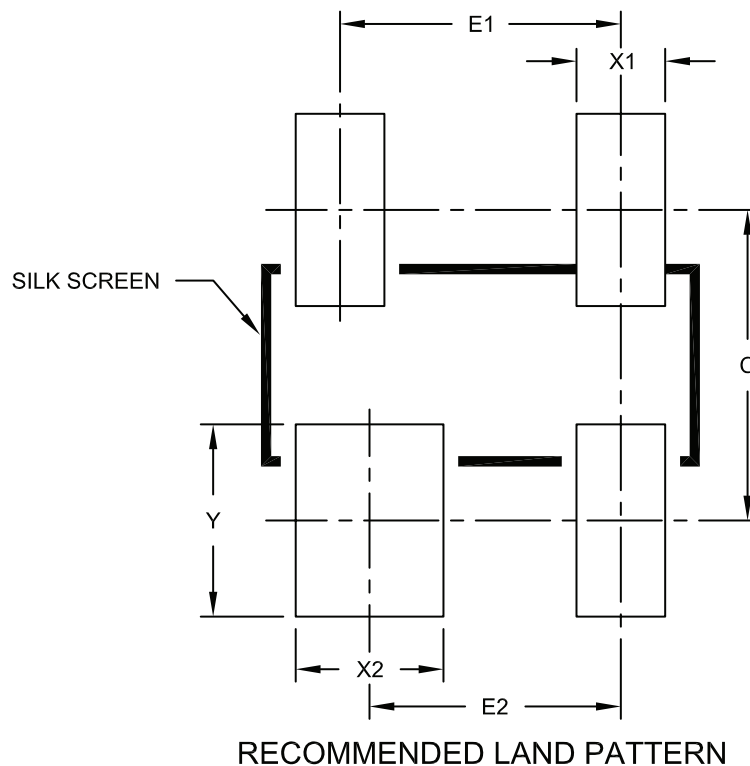

	Units	MILLIMETERS		
		MIN	NOM	MAX
Contact Pitch	E1	1.90 BSC		
Contact Pitch	E2	1.60 BSC		
Contact Width	X1			0.60
Contact Width	X2			1.00
Contact Length	Y			1.30
Contact Pad Spacing	C		2.10	

**Notes:**

1. Dimensioning and tolerancing per ASME Y14.5M

BSC: Basic Dimension. Theoretically exact value shown without tolerances.

Microchip Technology Drawing No. C04-2031A



**MICROCHIP**

---

---

**Package Outlines and Dimensions**

---

---

NOTES:

---

---

**Package Outlines and Dimensions**

---

---

**SOT-223**

**Package Outlines and Dimensions**

**3-Lead Plastic Small Outline Transistor (DB) [SOT-223]**

**Note:** For the most current package drawings, please see the Microchip Packaging Specification located at <http://www.microchip.com/packaging>

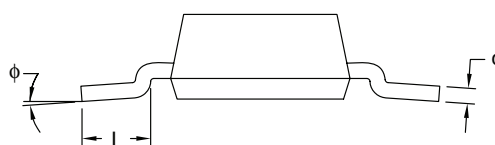
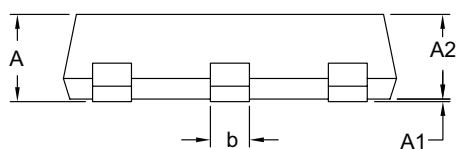
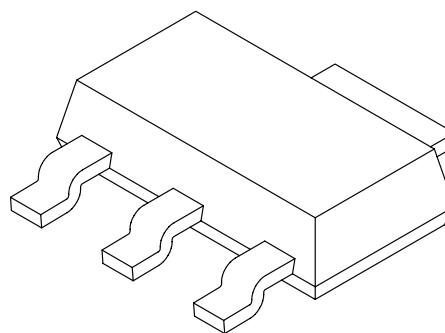
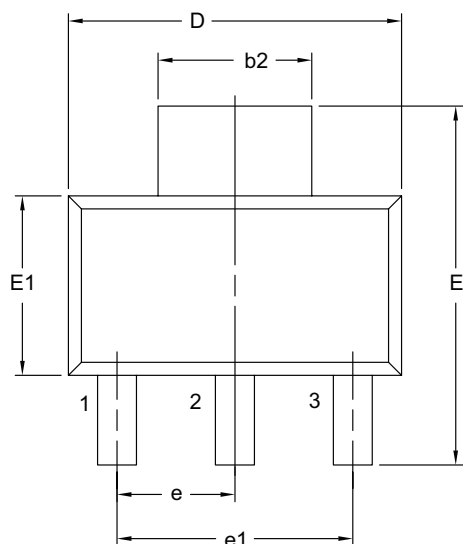

Dimension Limits	Units	MILLIMETERS		
		MIN	NOM	MAX
Number of Leads	N	3		
Lead Pitch	e	2.30 BSC		
Outside Lead Pitch	e1	4.60 BSC		
Overall Height	A	–	–	1.80
Standoff	A1	0.02	–	0.10
Molded Package Height	A2	1.50	1.60	1.70
Overall Width	E	6.70	7.00	7.30
Molded Package Width	E1	3.30	3.50	3.70
Overall Length	D	6.30	6.50	6.70
Lead Thickness	c	0.23	0.30	0.35
Lead Width	b	0.60	0.76	0.84
Tab Lead Width	b2	2.90	3.00	3.10
Foot Length	L	0.75	–	–
Lead Angle	φ	0°	–	10°

**Notes:**

- Dimensions D and E1 do not include mold flash or protrusions. Mold flash or protrusions shall not exceed 0.127 mm per side.
- Dimensioning and tolerancing per ASME Y14.5M.  
BSC: Basic Dimension. Theoretically exact value shown without tolerances.



---



---

## Footprint Outlines and Dimensions

---



---

### 3-Lead Plastic Small Outline Transistor (DB) [SOT-223]

**Note:** For the most current package drawings, please see the Microchip Packaging Specification located at <http://www.microchip.com/packaging>

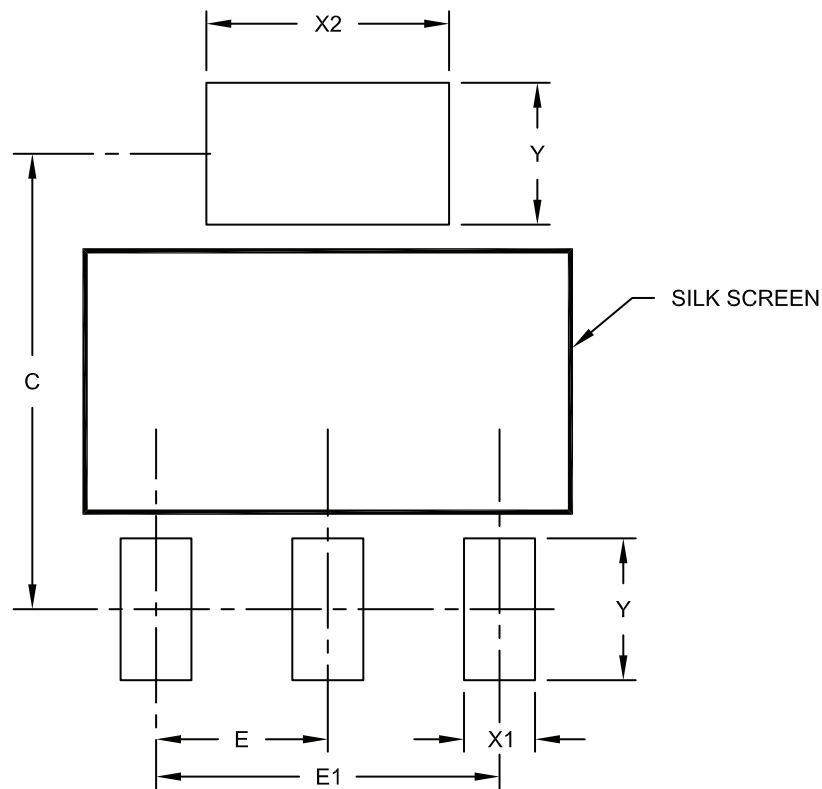

RECOMMENDED LAND PATTERN

		Units	MILLIMETERS		
Dimension Limits			MIN	NOM	MAX
Contact Pitch	E		2.30 BSC		
Overall Pitch	E1		4.60 BSC		
Contact Pad Spacing	C			6.10	
Contact Pad Width	X1				0.95
Contact Pad Width	X2				3.25
Contact Pad Length	Y				1.90

**Notes:**

1. Dimensioning and tolerancing per ASME Y14.5M

BSC: Basic Dimension. Theoretically exact value shown without tolerances.

Microchip Technology Drawing No. C04-2032A

**Package Outlines and Dimensions**

**5-Lead Plastic Small Outline Transistor (DC) [SOT-223]**

**Note:** For the most current package drawings, please see the Microchip Packaging Specification located at <http://www.microchip.com/packaging>

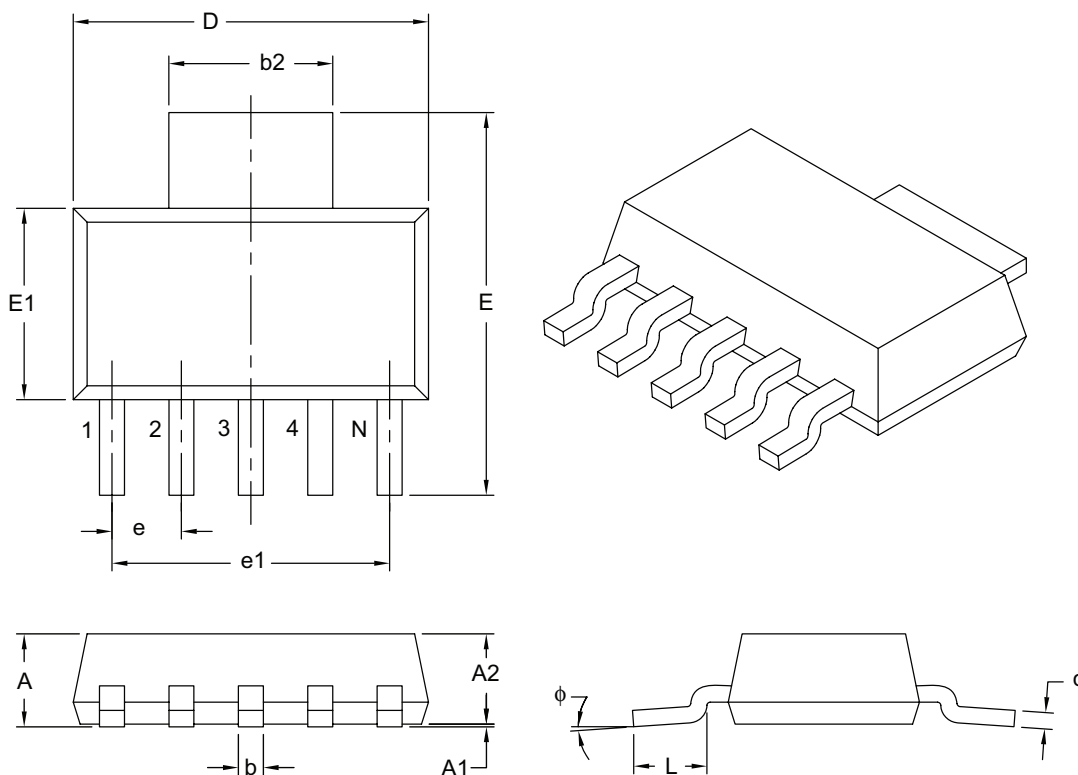

Dimension Limits	Units	MILLIMETERS		
		MIN	NOM	MAX
Number of Leads	N	5		
Lead Pitch	e	1.27 BSC		
Outside Lead Pitch	e1	5.08 BSC		
Overall Height	A	-	-	1.80
Standoff	A1	0.02	0.06	0.10
Molded Package Height	A2	1.55	1.60	1.65
Overall Width	E	6.86	7.00	7.26
Molded Package Width	E1	3.45	3.50	3.55
Overall Length	D	6.45	6.50	6.55
Lead Thickness	c	0.24	0.28	0.32
Lead Width	b	0.41	0.457	0.51
Tab Lead Width	b2	2.95	3.00	3.05
Foot Length	L	0.91	-	1.14
Lead Angle	$\phi$	0°	4°	8°

**Notes:**

- Dimensions D and E1 do not include mold flash or protrusions. Mold flash or protrusions shall not exceed 0.127 mm per side.
- Dimensioning and tolerancing per ASME Y14.5M.

BSC: Basic Dimension. Theoretically exact value shown without tolerances.

---



---

## Footprint Outlines and Dimensions

---



---

### 5-Lead Plastic Small Outline Transistor (DC) [SOT-223]

**Note:** For the most current package drawings, please see the Microchip Packaging Specification located at <http://www.microchip.com/packaging>

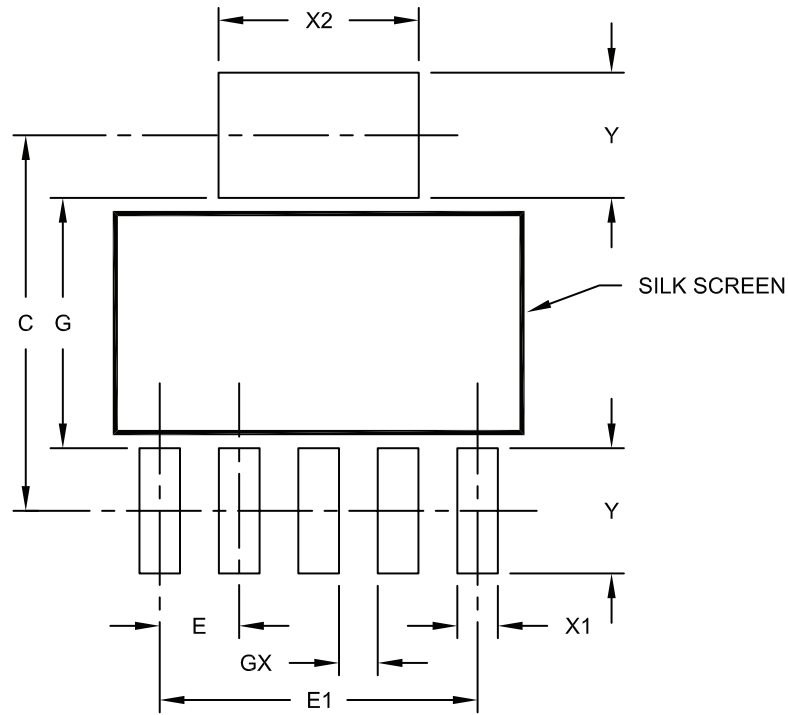

RECOMMENDED LAND PATTERN

Dimension Limits	Units	MILLIMETERS		
		MIN	NOM	MAX
Pad Pitch	E	1.27 BSC		
Overall Pad Pitch	E1	5.08 BSC		
Pad Spacing	C		6.00	
Pad Width	X1			0.65
Pad Width	X2			3.20
Pad Length	Y			2.00
Distance Between Pads	G	4.00		
Distance Between Pads	GX	0.62		

**Notes:**

1. Dimensioning and tolerancing per ASME Y14.5M

BSC: Basic Dimension. Theoretically exact value shown without tolerances.

Microchip Technology Drawing No. C04-2137A



**MICROCHIP**

---

---

**Package Outlines and Dimensions**

---

---

NOTES:

---

---

**Package Outlines and Dimensions**

---

---

**TO-92**

**Package Outlines and Dimensions**

**3-Lead Plastic Transistor Outline (TO) [TO-92]**

**Note:** For the most current package drawings, please see the Microchip Packaging Specification located at <http://www.microchip.com/packaging>

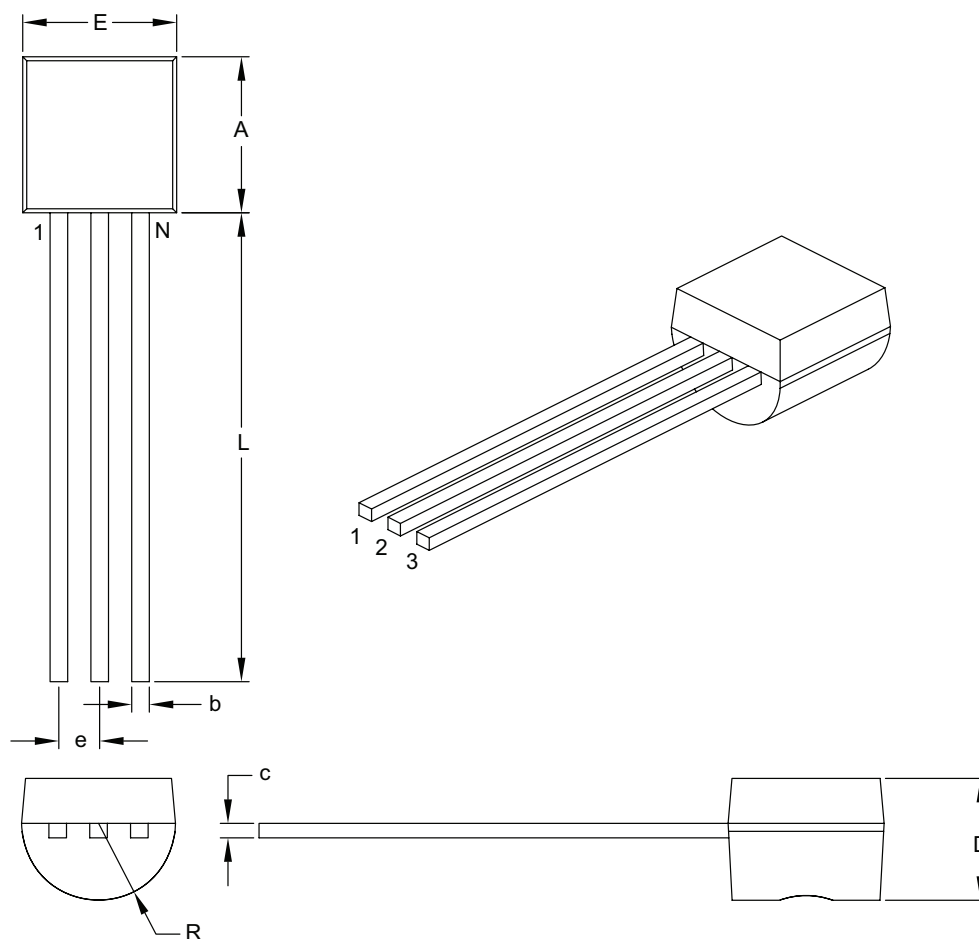

Dimension Limits	Units	INCHES	
		MIN	MAX
Number of Pins	N	3	
Pitch	e	.050 BSC	
Bottom to Package Flat	D	.125	.165
Overall Width	E	.175	.205
Overall Length	A	.170	.210
Molded Package Radius	R	.080	.105
Tip to Seating Plane	L	.500	–
Lead Thickness	c	.014	.021
Lead Width	b	.014	.022

**Notes:**

- Dimensions A and E do not include mold flash or protrusions. Mold flash or protrusions shall not exceed .005" per side.
- Dimensioning and tolerancing per ASME Y14.5M.

BSC: Basic Dimension. Theoretically exact value shown without tolerances.

---



---

## Package Outlines and Dimensions

---



---

### 3-Lead Plastic Transistor Outline (ZB) [TO-92]

**Note:** For the most current package drawings, please see the Microchip Packaging Specification located at <http://www.microchip.com/packaging>

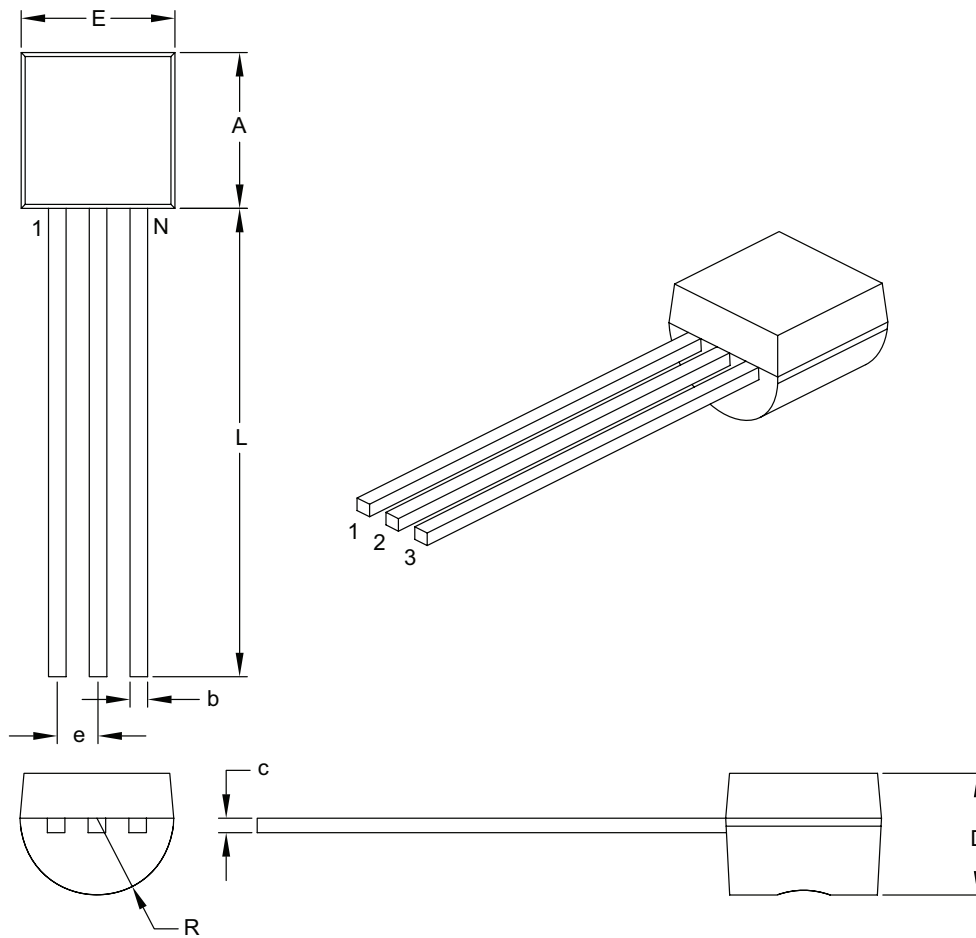

Dimension Limits	Units	INCHES	
		MIN	MAX
Number of Pins	N	3	
Pitch	e	.050 BSC	
Bottom to Package Flat	D	.125	.165
Overall Width	E	.175	.205
Overall Length	A	.170	.210
Molded Package Radius	R	.080	.105
Tip to Seating Plane	L	.500	–
Lead Thickness	c	.014	.021
Lead Width	b	.014	.022

**Notes:**

- Dimensions A and E do not include mold flash or protrusions. Mold flash or protrusions shall not exceed .005" per side.
- Dimensioning and tolerancing per ASME Y14.5M.

BSC: Basic Dimension. Theoretically exact value shown without tolerances.

Microchip Technology Drawing C04-101B



**MICROCHIP**

---

---

**Package Outlines and Dimensions**

---

---

**NOTES:**



---

---

**Package Outlines and Dimensions**

---

---

**TO-220**

## Package Outlines and Dimensions

### 3-Lead Plastic Transistor Outline (AB) [TO-220]

**Note:** For the most current package drawings, please see the Microchip Packaging Specification located at <http://www.microchip.com/packaging>

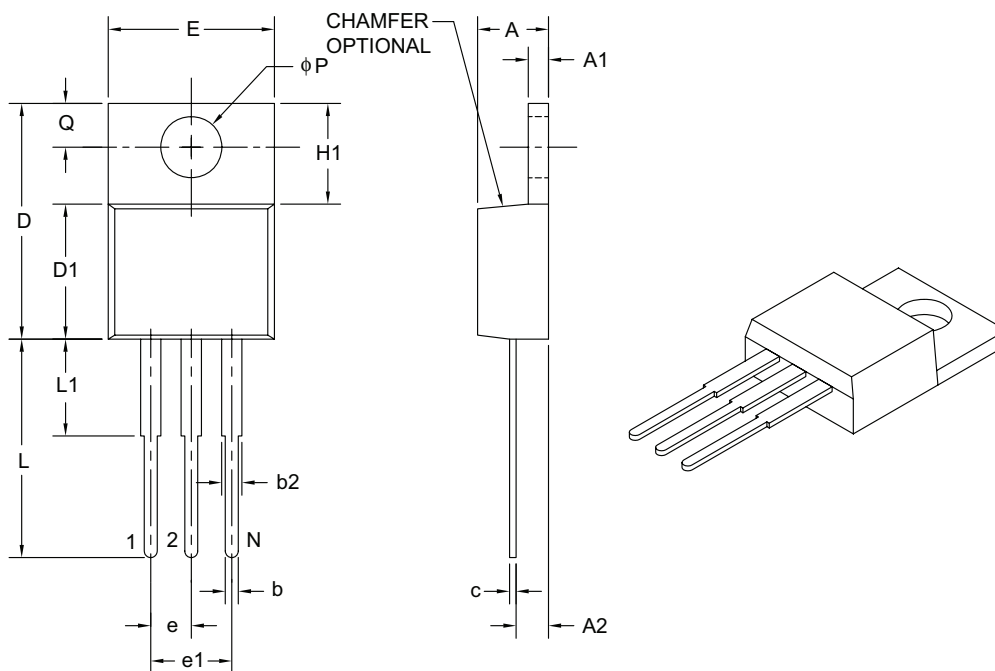

Dimension Limits	Units	INCHES		
		MIN	NOM	MAX
Number of Pins	N	3		
Pitch	e	.100 BSC		
Overall Pin Pitch	e1	.200 BSC		
Overall Height	A	.140	–	.190
Tab Thickness	A1	.020	–	.055
Base to Lead	A2	.080	–	.115
Overall Width	E	.357	–	.420
Mounting Hole Center	Q	.100	–	.120
Overall Length	D	.560	–	.650
Molded Package Length	D1	.330	–	.355
Tab Length	H1	.230	–	.270
Mounting Hole Diameter	φP	.139	–	.156
Lead Length	L	.500	–	.580
Lead Shoulder	L1	–	–	.250
Lead Thickness	c	.012	–	.024
Lead Width	b	.015	.027	.040
Shoulder Width	b2	.045	.057	.070

**Notes:**

- Dimensions D and E do not include mold flash or protrusions. Mold flash or protrusions shall not exceed .005" per side.
- Dimensioning and tolerancing per ASME Y14.5M.  
BSC: Basic Dimension. Theoretically exact value shown without tolerances.

---



---

## Package Outlines and Dimensions

---



---

### 5-Lead Plastic Transistor Outline (AT) [TO-220]

**Note:** For the most current package drawings, please see the Microchip Packaging Specification located at <http://www.microchip.com/packaging>

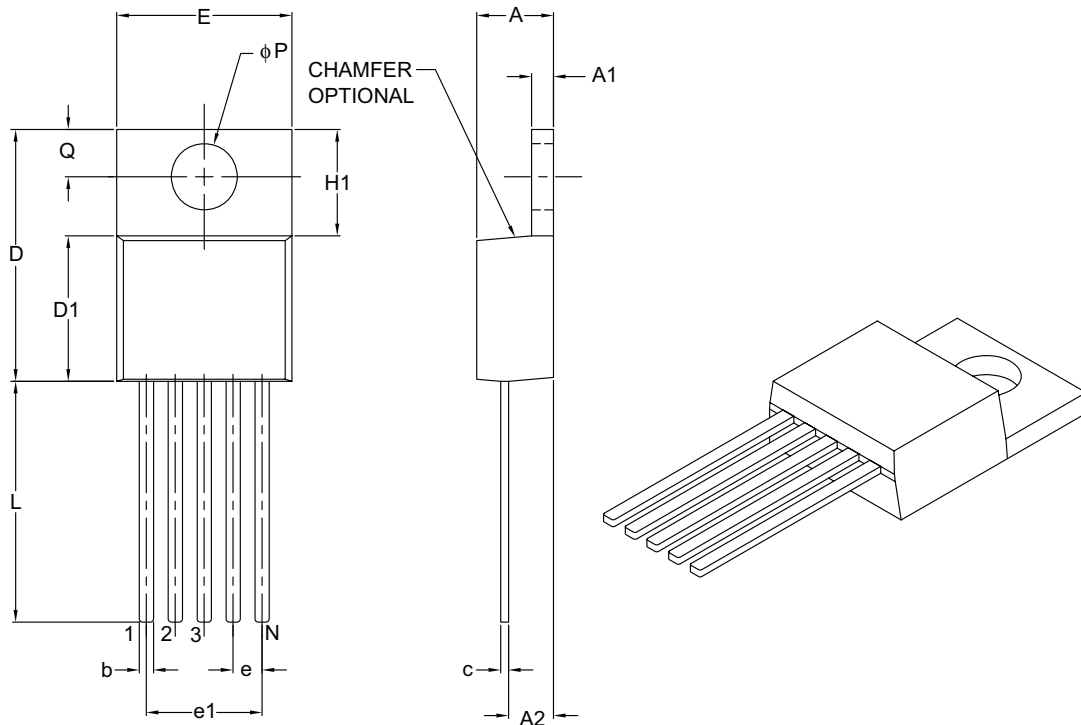

Dimension Limits	Units	INCHES		
		MIN	NOM	MAX
Number of Pins	N	5		
Pitch	e	.067 BSC		
Overall Pin Pitch	e1	.268 BSC		
Overall Height	A	.140	–	.190
Overall Width	E	.380	–	.420
Overall Length	D	.560	–	.650
Molded Package Length	D1	.330	–	.355
Tab Length	H1	.204	–	.293
Tab Thickness	A1	.020	–	.055
Mounting Hole Center	Q	.100	–	.120
Mounting Hole Diameter	φP	.139	–	.156
Lead Length	L	.482	–	.590
Base to Bottom of Lead	A2	.080	–	.115
Lead Thickness	c	.012	–	.025
Lead Width	b	.015	.027	.040

**Notes:**

1. Dimensions D and E do not include mold flash or protrusions. Mold flash or protrusions shall not exceed .005" per side.
2. Dimensioning and tolerancing per ASME Y14.5M.

BSC: Basic Dimension. Theoretically exact value shown without tolerances.

Microchip Technology Drawing C04-036B



**MICROCHIP**

---

---

**Package Outlines and Dimensions**

---

---

NOTES:

---

---

**Package Outlines and Dimensions**

---

---

**TSOT**

**Package Outlines and Dimensions**

**5-Lead Plastic Thin Small Outline Transistor (OS) [TSOT]**

**Note:** For the most current package drawings, please see the Microchip Packaging Specification located at <http://www.microchip.com/packaging>

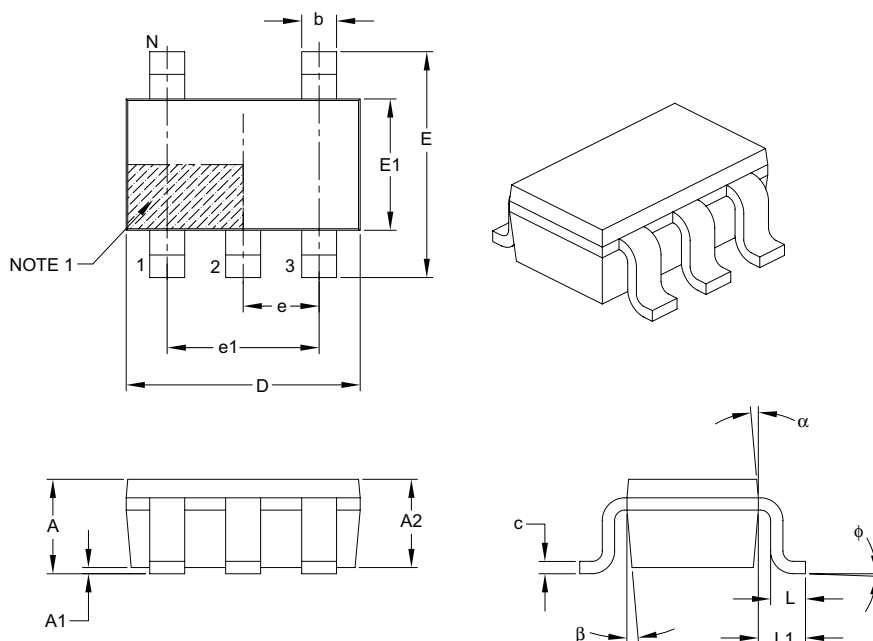

Dimension	Units	MILLIMETERS		
		MIN	NOM	MAX
Number of Leads	N	5		
Lead Pitch	e	0.95 BSC		
Outside Lead Pitch	e1	1.90 BSC		
Overall Height	A	–	–	1.10
Molded Package Thickness	A2	0.70	0.90	1.00
Standoff	A1	0.00	–	0.10
Overall Width	E	2.80 BSC		
Molded Package Width	E1	1.60 BSC		
Overall Length	D	2.90 BSC		
Foot Length	L	0.30	0.45	0.60
Footprint	L1	0.60 REF		
Foot Angle	$\phi$	0°	4°	8°
Lead Thickness	c	0.08	–	0.20
Lead Width	b	0.30	–	0.50
Mold Draft Angle Top	$\alpha$	4°	10°	12°
Mold Draft Angle Bottom	$\beta$	4°	10°	12°

**Notes:**

- Pin 1 visual index feature may vary, but must be located within the hatched area.
- Dimensions D and E1 do not include mold flash or protrusions. Mold flash or protrusions shall not exceed 0.15 mm per side.
- Dimensioning and tolerancing per ASME Y14.5M.

BSC: Basic Dimension. Theoretically exact value shown without tolerances.

REF: Reference Dimension, usually without tolerance, for information purposes only.

---



---

## Footprint Outlines and Dimensions

---



---

### 5-Lead Plastic Thin Small Outline Transistor (OS) [TSOT]

**Note:** For the most current package drawings, please see the Microchip Packaging Specification located at <http://www.microchip.com/packaging>

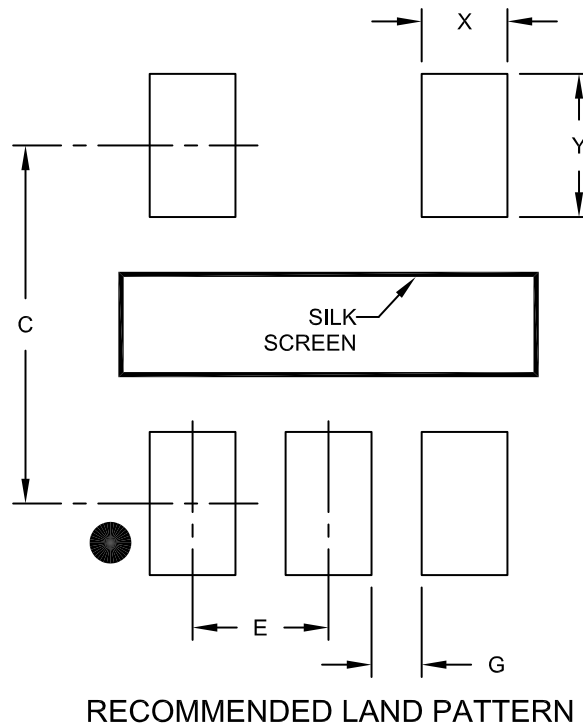

Dimension Limits	Units	MILLIMETERS		
		MIN	NOM	MAX
Contact Pitch	E	0.95 BSC		
Contact Pad Spacing	C		2.80	
Contact Pad Width (X5)	X			0.60
Contact Pad Length (X5)	Y			1.10
Distance Between Pads	G	0.35		

**Notes:**

1. Dimensioning and tolerancing per ASME Y14.5M

BSC: Basic Dimension. Theoretically exact value shown without tolerances.

Microchip Technology Drawing No. C04-2128A

**Package Outlines and Dimensions**

**6-Lead Thin Small Outline Transistor (OS) [TSOT]**

**Note:** For the most current package drawings, please see the Microchip Packaging Specification located at <http://www.microchip.com/packaging>

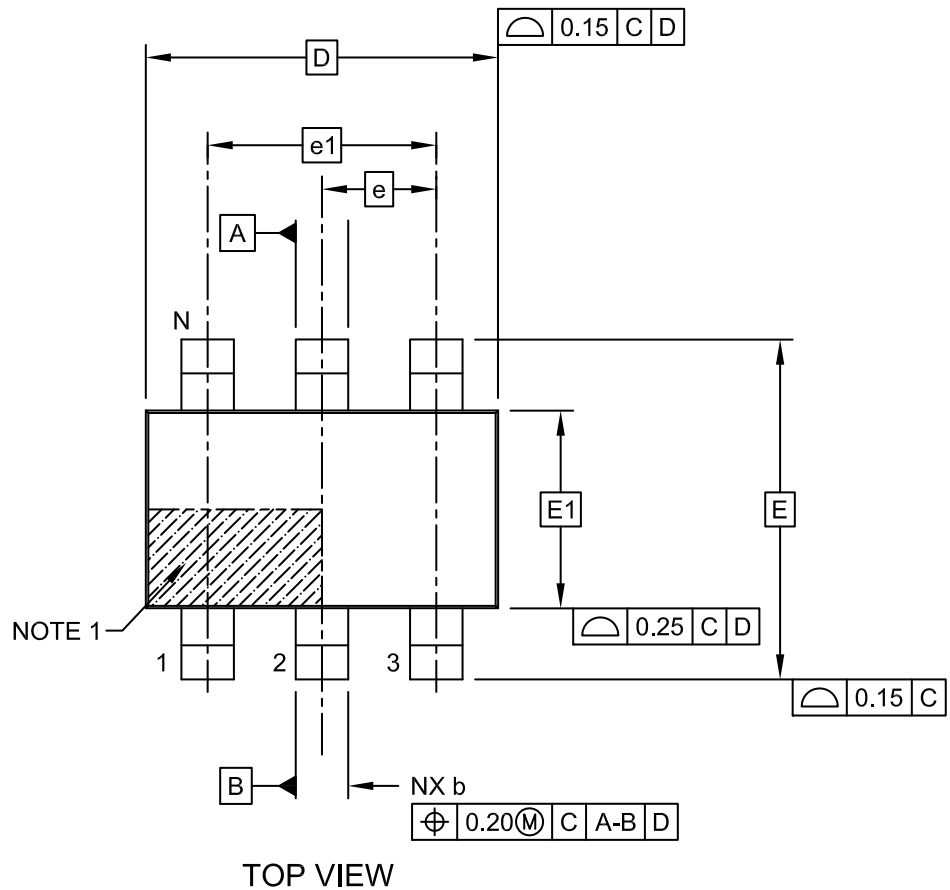

A

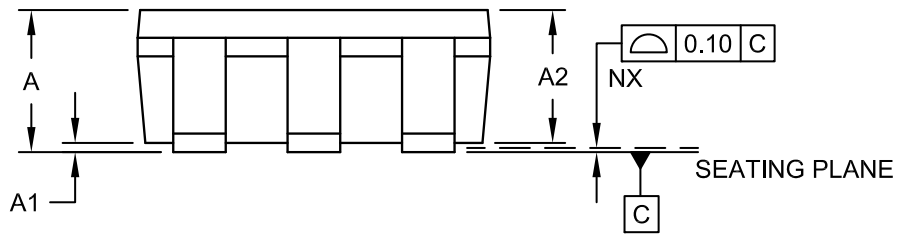

A

SEE SHEET 2

SIDE VIEW



---



---

## Package Outlines and Dimensions

---



---

### 6-Lead Thin Small Outline Transistor (OS) [TSOT]

**Note:** For the most current package drawings, please see the Microchip Packaging Specification located at <http://www.microchip.com/packaging>

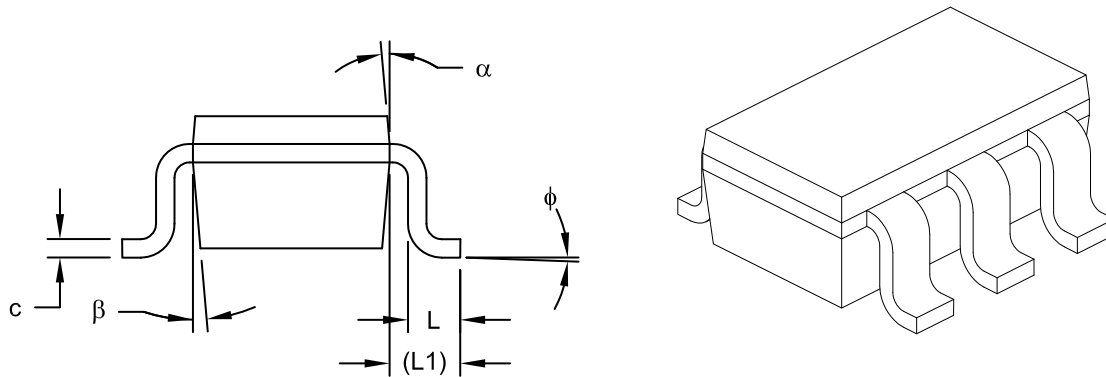

VIEW A-A

Dimension	Units	MILLIMETERS		
	Limits	MIN	NOM	MAX
Number of Leads	N	6		
Lead Pitch	e	0.95 BSC		
Outside Lead Pitch	e1	1.90 BSC		
Overall Height	A	-	-	1.10
Molded Package Thickness	A2	0.70	0.90	1.00
Standoff	A1	0.00	-	0.10
Overall Width	E	2.80 BSC		
Molded Package Width	E1	1.60 BSC		
Overall Length	D	2.90 BSC		
Foot Length	L	0.30	0.45	0.60
Footprint	L1	0.60 REF		
Foot Angle	φ	0°	4°	8°
Lead Thickness	c	0.08	-	0.20
Lead Width	θ	0.30	-	0.50
Mold Draft Angle Top	α	4°	10°	12°
Mold Draft Angle Botton	β	4°	10°	12°

**Notes:**

1. Pin 1 visual index feature may vary, but must be located within the hatched area.
2. Dimensions D and E1 do not include mold flash or protrusions. Mold flash or protrusions shall not exceed 0.15mm per side.
3. Dimensioning and tolerancing per ASME Y14.5M.  
 BSC: Basic Dimension. Theoretically exact value shown without tolerances.  
 REF: Reference Dimension, usually without tolerance, for information purposes only.



**MICROCHIP**

---

---

**Package Outlines and Dimensions**

---

---

NOTES:

---

---

**Package Outlines and Dimensions**

---

---

**PDIP**

**Package Outlines and Dimensions**

**8-Lead Plastic Dual In-Line (P) - 300 mil Body [PDIP]**

**Note:** For the most current package drawings, please see the Microchip Packaging Specification located at <http://www.microchip.com/packaging>

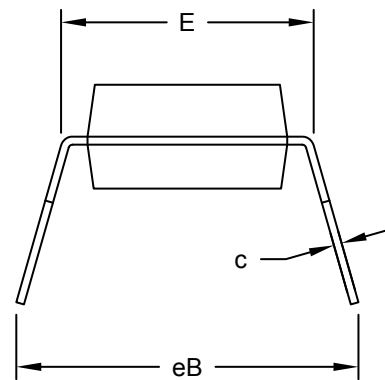
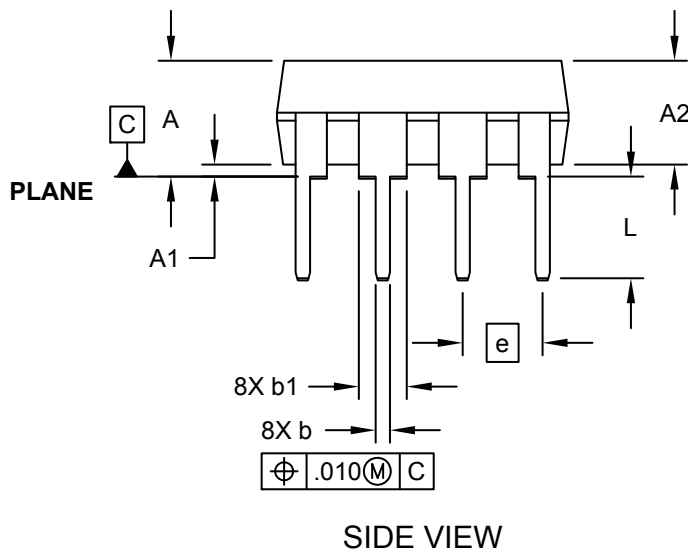
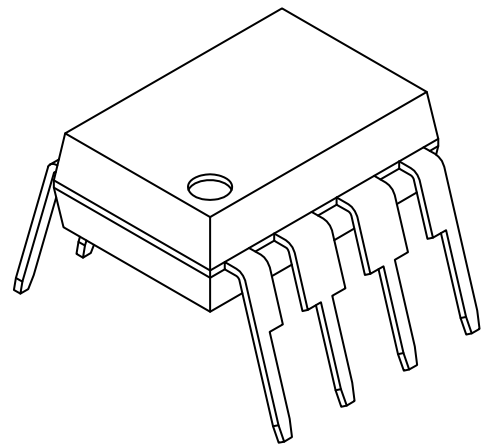
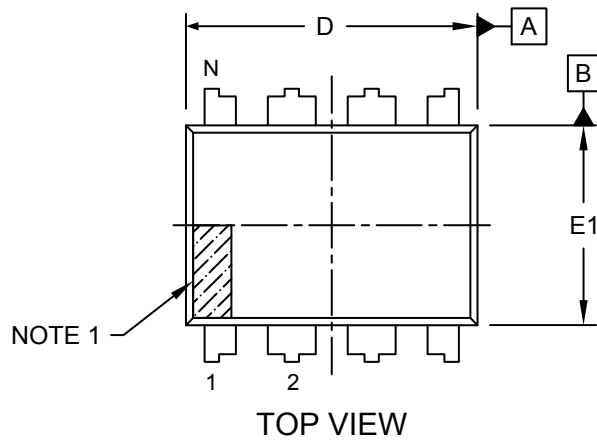

---



---

## Package Outlines and Dimensions

---



---

### 8-Lead Plastic Dual In-Line (P) - 300 mil Body [PDIP]

**Note:** For the most current package drawings, please see the Microchip Packaging Specification located at <http://www.microchip.com/packaging>

#### ALTERNATE LEAD DESIGN (VENDOR DEPENDENT)

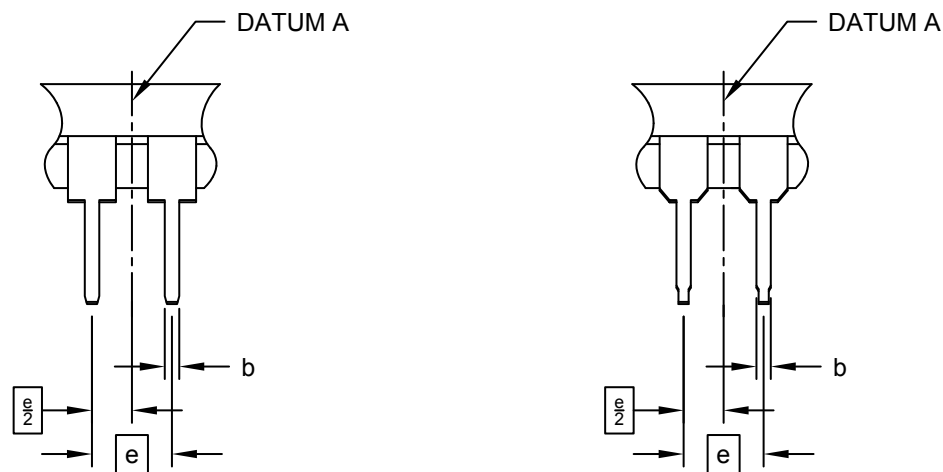

		Units	INCHES		
		Dimension Limits	MIN	NOM	MAX
Number of Pins	N		8		
Pitch	e		.100 BSC		
Top to Seating Plane	A		-	-	.210
Molded Package Thickness	A2		.115	.130	.195
Base to Seating Plane	A1		.015	-	-
Shoulder to Shoulder Width	E		.290	.310	.325
Molded Package Width	E1		.240	.250	.280
Overall Length	D		.348	.365	.400
Tip to Seating Plane	L		.115	.130	.150
Lead Thickness	c		.008	.010	.015
Upper Lead Width	b1		.040	.060	.070
Lower Lead Width	b		.014	.018	.022
Overall Row Spacing	§	eB	-	-	.430

**Notes:**

1. Pin 1 visual index feature may vary, but must be located within the hatched area.
2. § Significant Characteristic
3. Dimensions D and E1 do not include mold flash or protrusions. Mold flash or protrusions shall not exceed .010" per side.
4. Dimensioning and tolerancing per ASME Y14.5M

BSC: Basic Dimension. Theoretically exact value shown without tolerances.

**Package Outlines and Dimensions**

**8-Lead Plastic Dual In-Line (PA) - 300 mil Body [PDIP]**

**Note:** For the most current package drawings, please see the Microchip Packaging Specification located at <http://www.microchip.com/packaging>

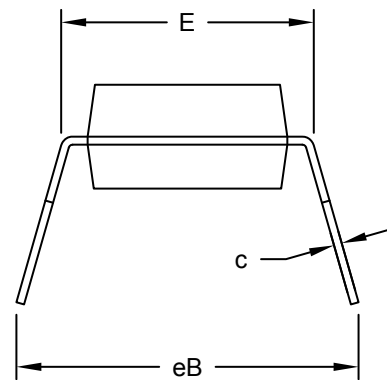
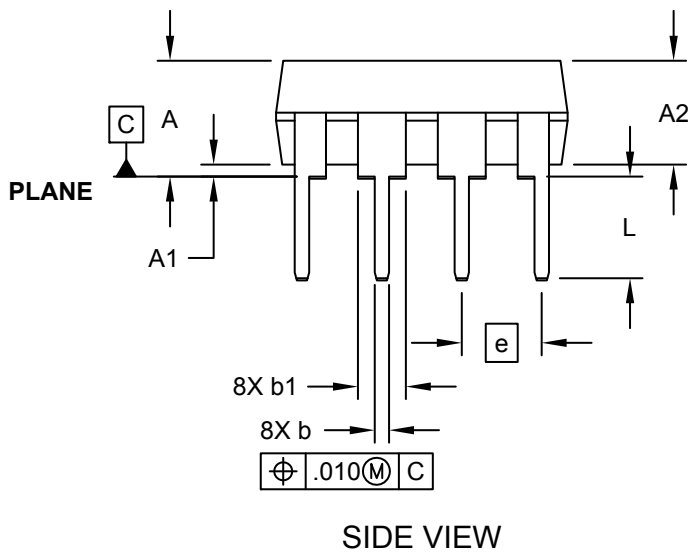
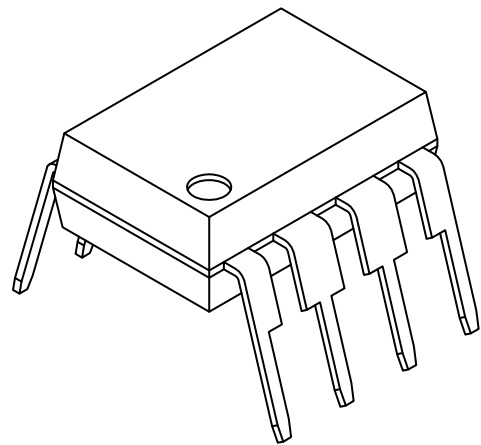
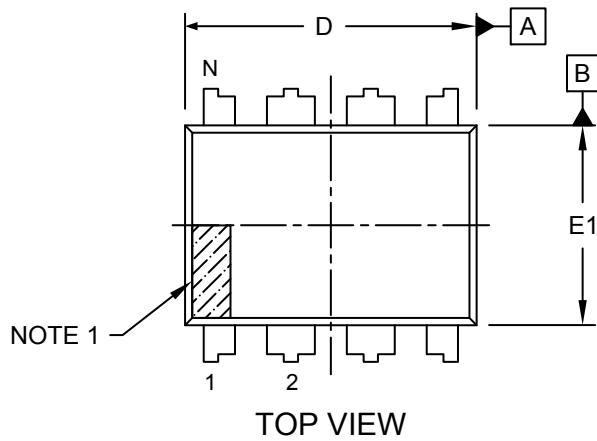

## Package Outlines and Dimensions

### 8-Lead Plastic Dual In-Line (PA) - 300 mil Body [PDIP]

**Note:** For the most current package drawings, please see the Microchip Packaging Specification located at <http://www.microchip.com/packaging>

ALTERNATE LEAD DESIGN  
(VENDOR DEPENDENT)

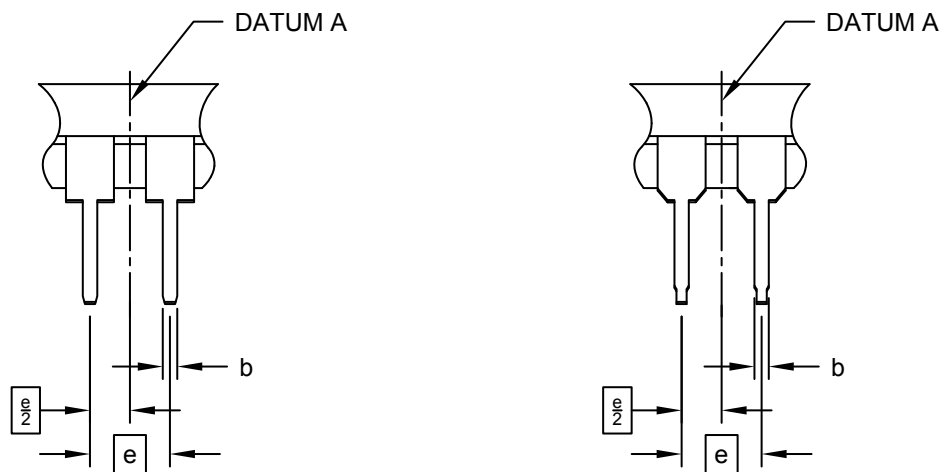

		Units	INCHES		
Dimension Limits			MIN	NOM	MAX
Number of Pins	N		8		
Pitch	e		.100 BSC		
Top to Seating Plane	A	-	-		.210
Molded Package Thickness	A2	.115	.130		.195
Base to Seating Plane	A1	.015	-		-
Shoulder to Shoulder Width	E	.290	.310		.325
Molded Package Width	E1	.240	.250		.280
Overall Length	D	.348	.365		.400
Tip to Seating Plane	L	.115	.130		.150
Lead Thickness	c	.008	.010		.015
Upper Lead Width	b1	.040	.060		.070
Lower Lead Width	b	.014	.018		.022
Overall Row Spacing	§ eB	-	-		.430

**Notes:**

1. Pin 1 visual index feature may vary, but must be located within the hatched area.
2. § Significant Characteristic
3. Dimensions D and E1 do not include mold flash or protrusions. Mold flash or protrusions shall not exceed .010" per side.
4. Dimensioning and tolerancing per ASME Y14.5M

BSC: Basic Dimension. Theoretically exact value shown without tolerances.

**Package Outlines and Dimensions**

**14-Lead Plastic Dual In-Line (P) – 300 mil Body [PDIP]**

**Note:** For the most current package drawings, please see the Microchip Packaging Specification located at <http://www.microchip.com/packaging>

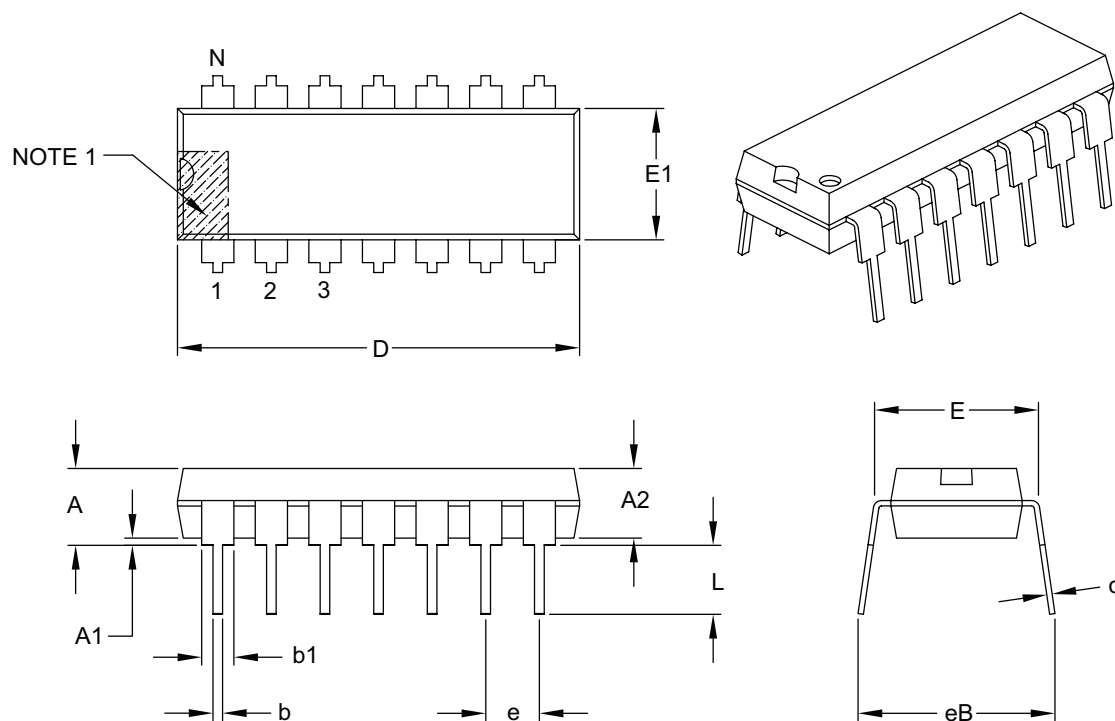

Dimension Limits	Units	INCHES		
		MIN	NOM	MAX
Number of Pins	N	14		
Pitch	e	.100 BSC		
Top to Seating Plane	A	–	–	.210
Molded Package Thickness	A2	.115	.130	.195
Base to Seating Plane	A1	.015	–	–
Shoulder to Shoulder Width	E	.290	.310	.325
Molded Package Width	E1	.240	.250	.280
Overall Length	D	.735	.750	.775
Tip to Seating Plane	L	.115	.130	.150
Lead Thickness	c	.008	.010	.015
Upper Lead Width	b1	.045	.060	.070
Lower Lead Width	b	.014	.018	.022
Overall Row Spacing §	eB	–	–	.430

**Notes:**

- Pin 1 visual index feature may vary, but must be located with the hatched area.
- § Significant Characteristic.
- Dimensions D and E1 do not include mold flash or protrusions. Mold flash or protrusions shall not exceed .010" per side.
- Dimensioning and tolerancing per ASME Y14.5M.

BSC: Basic Dimension. Theoretically exact value shown without tolerances.

Microchip Technology Drawing C04-005B



---



---

## Package Outlines and Dimensions

---



---

### 14-Lead Plastic Dual In-Line (PD) – 300 mil Body [PDIP]

**Note:** For the most current package drawings, please see the Microchip Packaging Specification located at <http://www.microchip.com/packaging>

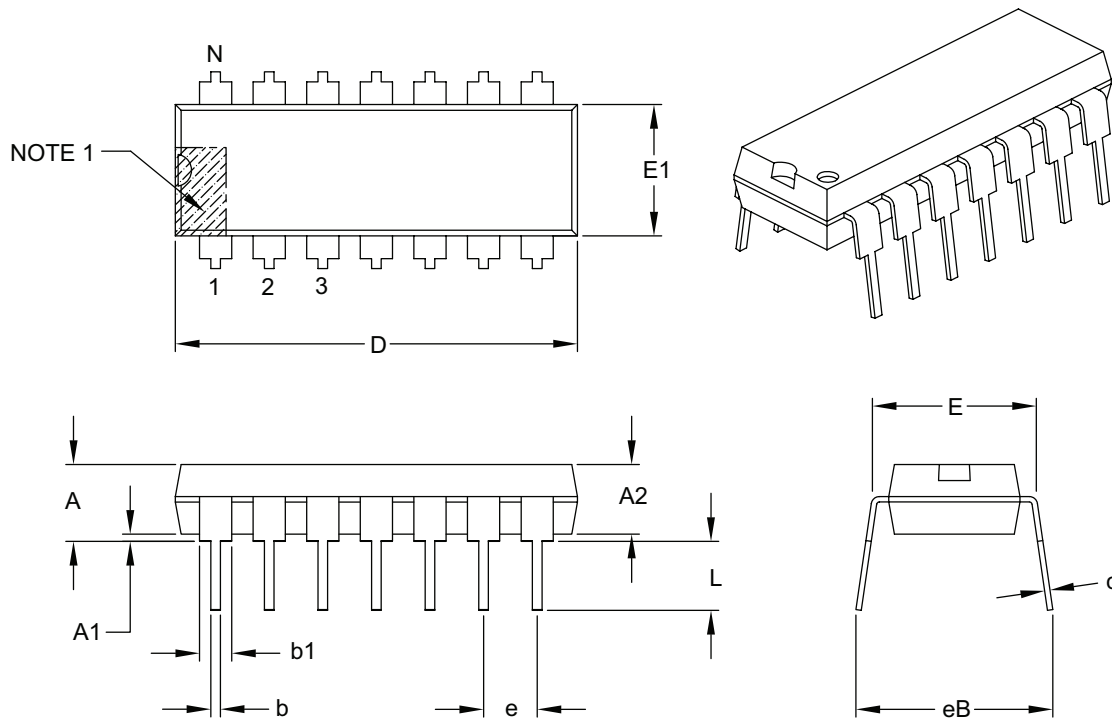

Dimension Limits	Units	INCHES		
		MIN	NOM	MAX
Number of Pins	N	14		
Pitch	e	.100 BSC		
Top to Seating Plane	A	–	–	.210
Molded Package Thickness	A2	.115	.130	.195
Base to Seating Plane	A1	.015	–	–
Shoulder to Shoulder Width	E	.290	.310	.325
Molded Package Width	E1	.240	.250	.280
Overall Length	D	.735	.750	.775
Tip to Seating Plane	L	.115	.130	.150
Lead Thickness	c	.008	.010	.015
Upper Lead Width	b1	.045	.060	.070
Lower Lead Width	b	.014	.018	.022
Overall Row Spacing §	eB	–	–	.430

**Notes:**

1. Pin 1 visual index feature may vary, but must be located with the hatched area.
2. § Significant Characteristic.
3. Dimensions D and E1 do not include mold flash or protrusions. Mold flash or protrusions shall not exceed .010" per side.
4. Dimensioning and tolerancing per ASME Y14.5M.

BSC: Basic Dimension. Theoretically exact value shown without tolerances.

Microchip Technology Drawing C04-005B

**Package Outlines and Dimensions**

**16-Lead Plastic Dual In-Line (P) – 300 mil Body [PDIP]**

**Note:** For the most current package drawings, please see the Microchip Packaging Specification located at <http://www.microchip.com/packaging>

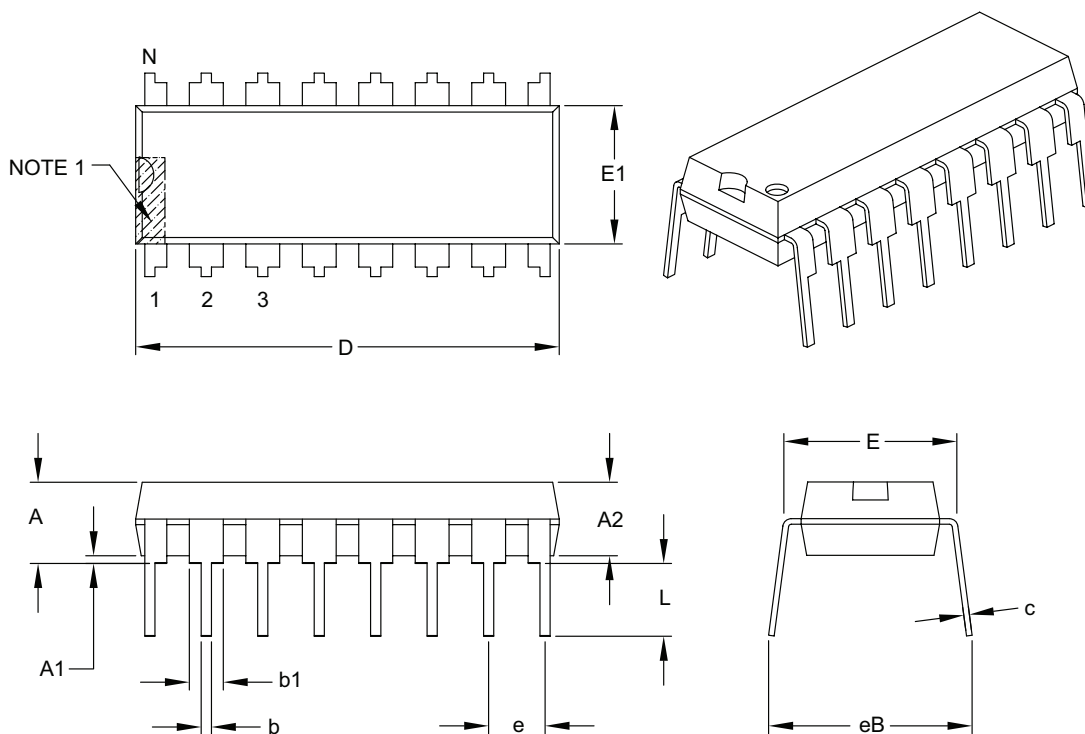

Dimension Limits	Units	INCHES		
		MIN	NOM	MAX
Number of Pins	N	16		
Pitch	e	.100 BSC		
Top to Seating Plane	A	–	–	.210
Molded Package Thickness	A2	.115	.130	.195
Base to Seating Plane	A1	.015	–	–
Shoulder to Shoulder Width	E	.290	.310	.325
Molded Package Width	E1	.240	.250	.280
Overall Length	D	.735	.755	.775
Tip to Seating Plane	L	.115	.130	.150
Lead Thickness	c	.008	.010	.015
Upper Lead Width	b1	.045	.060	.070
Lower Lead Width	b	.014	.018	.022
Overall Row Spacing §	eB	–	–	.430

**Notes:**

1. Pin 1 visual index feature may vary, but must be located within the hatched area.
2. § Significant Characteristic.
3. Dimensions D and E1 do not include mold flash or protrusions. Mold flash or protrusions shall not exceed .010" per side.
4. Dimensioning and tolerancing per ASME Y14.5M.  
BSC: Basic Dimension. Theoretically exact value shown without tolerances.

---



---

## Package Outlines and Dimensions

---



---

### 16-Lead Plastic Dual In-Line (PE) – 300 mil Body [PDIP]

**Note:** For the most current package drawings, please see the Microchip Packaging Specification located at <http://www.microchip.com/packaging>

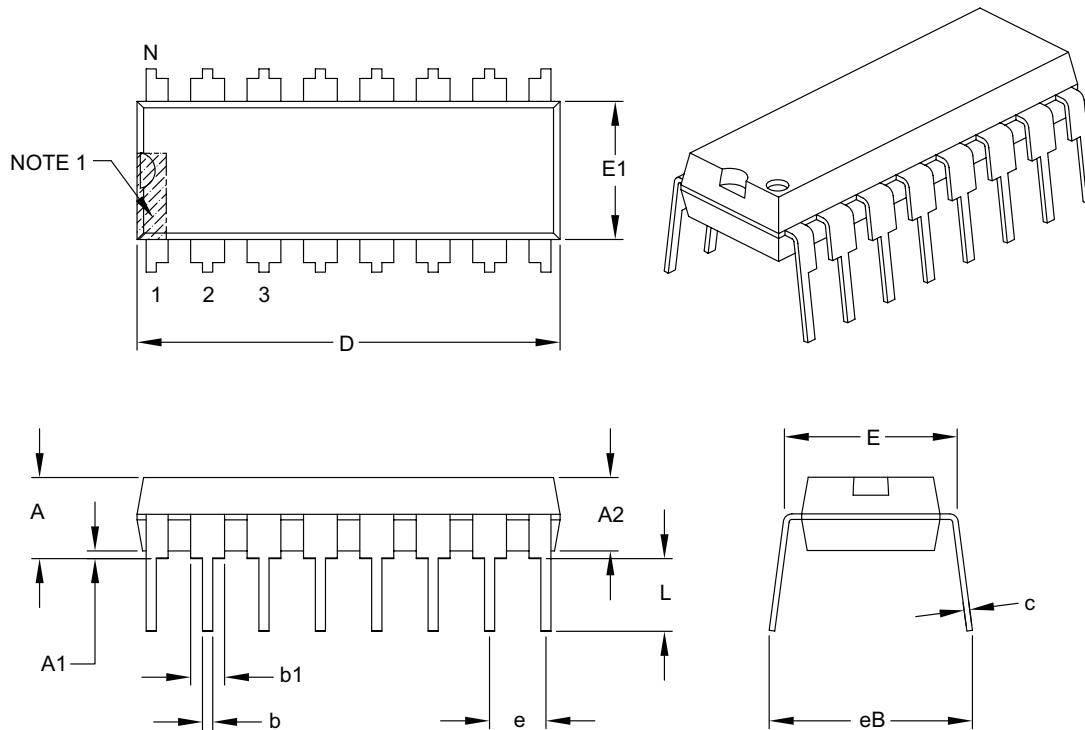

Dimension Limits	Units	INCHES		
		MIN	NOM	MAX
Number of Pins	N	16		
Pitch	e	.100 BSC		
Top to Seating Plane	A	–	–	.210
Molded Package Thickness	A2	.115	.130	.195
Base to Seating Plane	A1	.015	–	–
Shoulder to Shoulder Width	E	.290	.310	.325
Molded Package Width	E1	.240	.250	.280
Overall Length	D	.735	.755	.775
Tip to Seating Plane	L	.115	.130	.150
Lead Thickness	c	.008	.010	.015
Upper Lead Width	b1	.045	.060	.070
Lower Lead Width	b	.014	.018	.022
Overall Row Spacing §	eB	–	–	.430

**Notes:**

1. Pin 1 visual index feature may vary, but must be located within the hatched area.
2. § Significant Characteristic.
3. Dimensions D and E1 do not include mold flash or protrusions. Mold flash or protrusions shall not exceed .010" per side.
4. Dimensioning and tolerancing per ASME Y14.5M.  
BSC: Basic Dimension. Theoretically exact value shown without tolerances.

**Package Outlines and Dimensions**

**18-Lead Plastic Dual In-Line (P) – 300 mil Body [PDIP]**

**Note:** For the most current package drawings, please see the Microchip Packaging Specification located at <http://www.microchip.com/packaging>

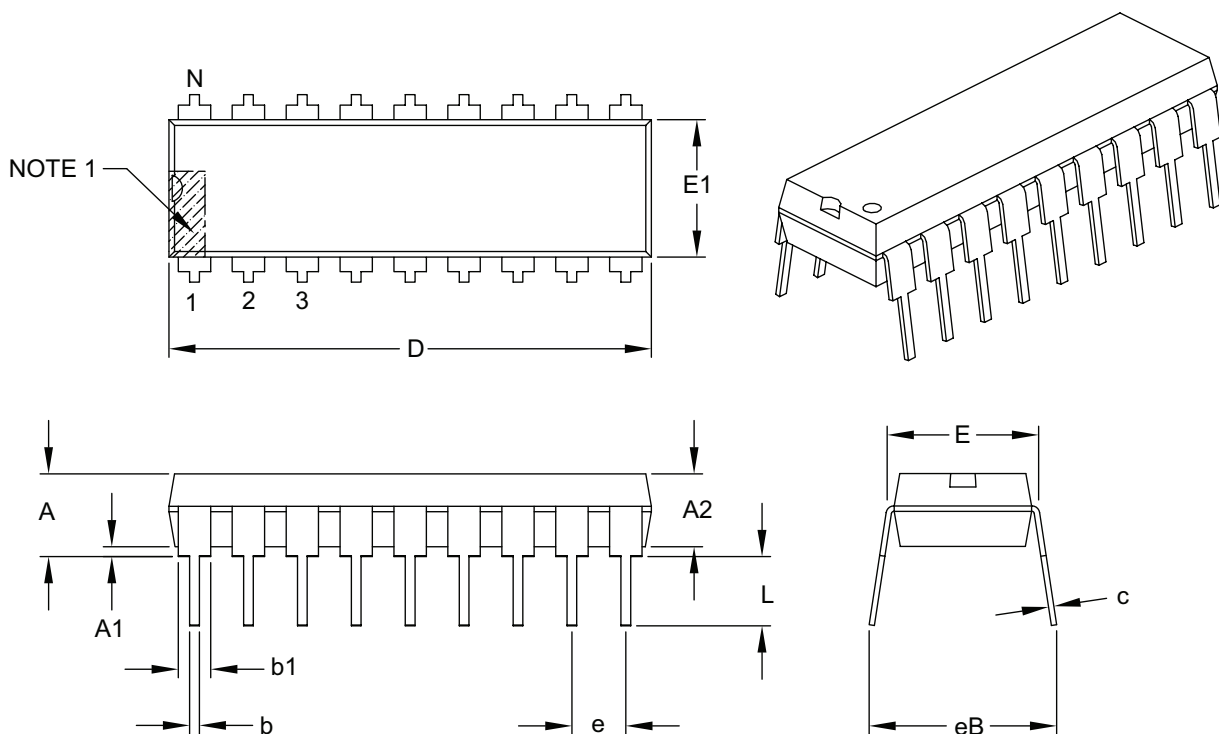

Dimension Limits	Units	INCHES		
		MIN	NOM	MAX
Number of Pins	N	18		
Pitch	e	.100 BSC		
Top to Seating Plane	A	–	–	.210
Molded Package Thickness	A2	.115	.130	.195
Base to Seating Plane	A1	.015	–	–
Shoulder to Shoulder Width	E	.300	.310	.325
Molded Package Width	E1	.240	.250	.280
Overall Length	D	.880	.900	.920
Tip to Seating Plane	L	.115	.130	.150
Lead Thickness	c	.008	.010	.014
Upper Lead Width	b1	.045	.060	.070
Lower Lead Width	b	.014	.018	.022
Overall Row Spacing §	eB	–	–	.430

**Notes:**

- Pin 1 visual index feature may vary, but must be located within the hatched area.
- § Significant Characteristic.
- Dimensions D and E1 do not include mold flash or protrusions. Mold flash or protrusions shall not exceed .010" per side.
- Dimensioning and tolerancing per ASME Y14.5M.

BSC: Basic Dimension. Theoretically exact value shown without tolerances.

---



---

## Package Outlines and Dimensions

---



---

### 20-Lead Plastic Dual In-Line (P) – 300 mil Body [PDIP]

**Note:** For the most current package drawings, please see the Microchip Packaging Specification located at <http://www.microchip.com/packaging>

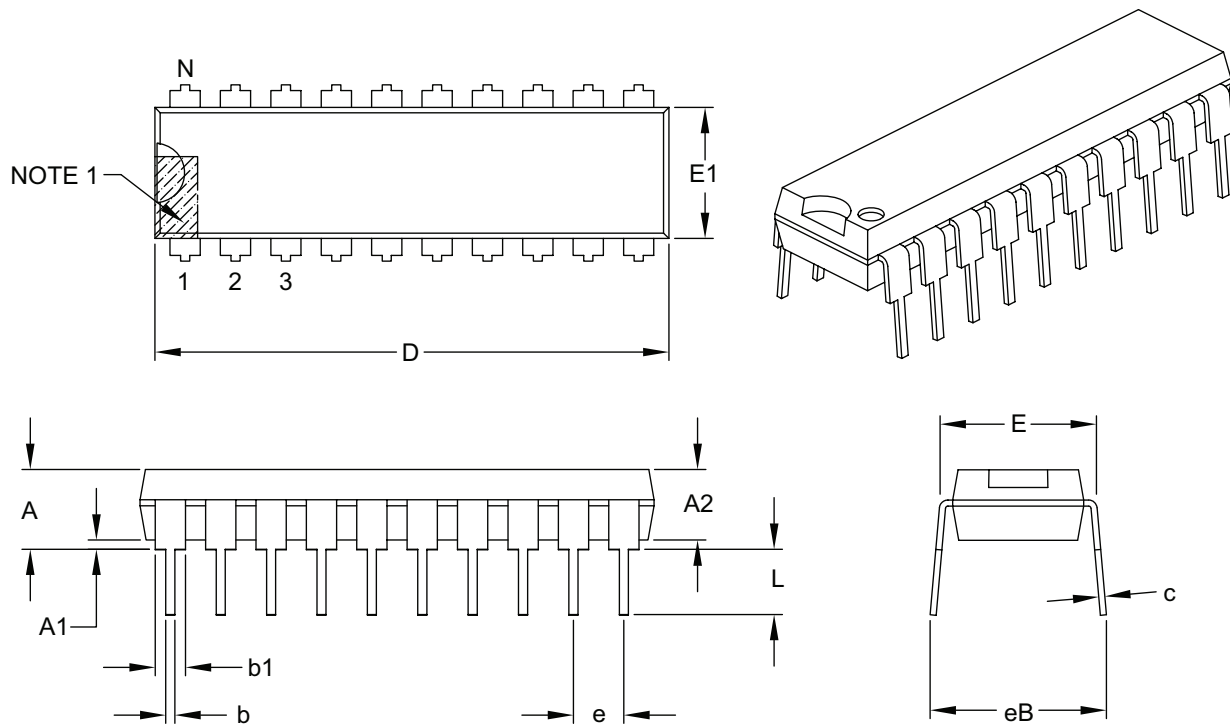

Dimension Limits	Units	INCHES		
		MIN	NOM	MAX
Number of Pins	N	20		
Pitch	e	.100 BSC		
Top to Seating Plane	A	–	–	.210
Molded Package Thickness	A2	.115	.130	.195
Base to Seating Plane	A1	.015	–	–
Shoulder to Shoulder Width	E	.300	.310	.325
Molded Package Width	E1	.240	.250	.280
Overall Length	D	.980	1.030	1.060
Tip to Seating Plane	L	.115	.130	.150
Lead Thickness	c	.008	.010	.015
Upper Lead Width	b1	.045	.060	.070
Lower Lead Width	b	.014	.018	.022
Overall Row Spacing §	eB	–	–	.430

**Notes:**

1. Pin 1 visual index feature may vary, but must be located within the hatched area.
2. § Significant Characteristic.
3. Dimensions D and E1 do not include mold flash or protrusions. Mold flash or protrusions shall not exceed .010" per side.
4. Dimensioning and tolerancing per ASME Y14.5M.

BSC: Basic Dimension. Theoretically exact value shown without tolerances.

Microchip Technology Drawing C04-019B

**Package Outlines and Dimensions**

**24-Lead Plastic Dual In-Line (P) – 600 mil Body [PDIP]**

**Note:** For the most current package drawings, please see the Microchip Packaging Specification located at <http://www.microchip.com/packaging>

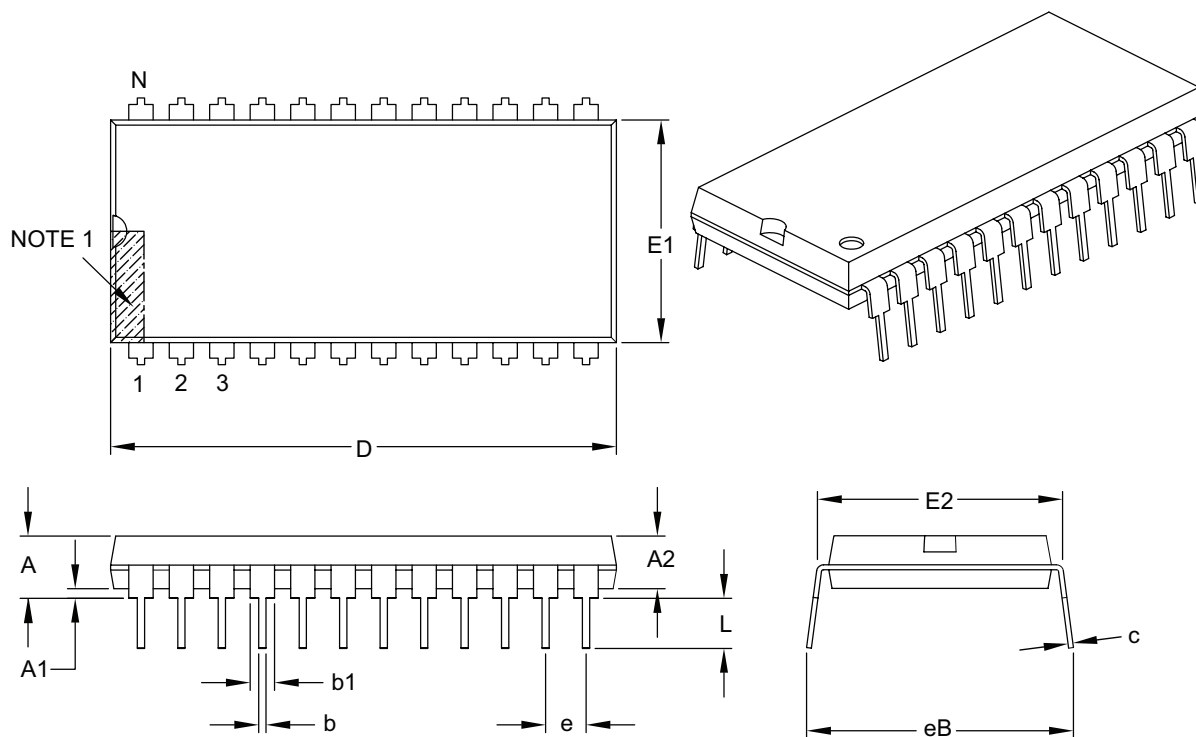

Dimension Limits	Units	INCHES		
		MIN	NOM	MAX
Number of Pins	N	24		
Pitch	e	.100 BSC		
Top to Seating Plane	A	–	–	.250
Molded Package Thickness	A2	.125	–	.195
Base to Seating Plane	A1	.015	–	–
Shoulder to Shoulder Width	E	.590	–	.625
Molded Package Width	E1	.485	–	.580
Overall Length	D	1.150	–	1.290
Tip to Seating Plane	L	.115	–	.200
Lead Thickness	c	.008	–	.015
Upper Lead Width	b1	.030	–	.070
Lower Lead Width	b	.014	–	.022
Overall Row Spacing §	eB	–	–	.700

**Notes:**

1. Pin 1 visual index feature may vary, but must be located within the hatched area.
2. § Significant Characteristic.
3. Dimensions D and E1 do not include mold flash or protrusions. Mold flash or protrusions shall not exceed .010" per side.
4. Dimensioning and tolerancing per ASME Y14.5M.  
BSC: Basic Dimension. Theoretically exact value shown without tolerances.

---



---

## Package Outlines and Dimensions

---



---

### 24-Lead Plastic Dual In-Line (PG) – 600 mil Body [PDIP]

**Note:** For the most current package drawings, please see the Microchip Packaging Specification located at <http://www.microchip.com/packaging>

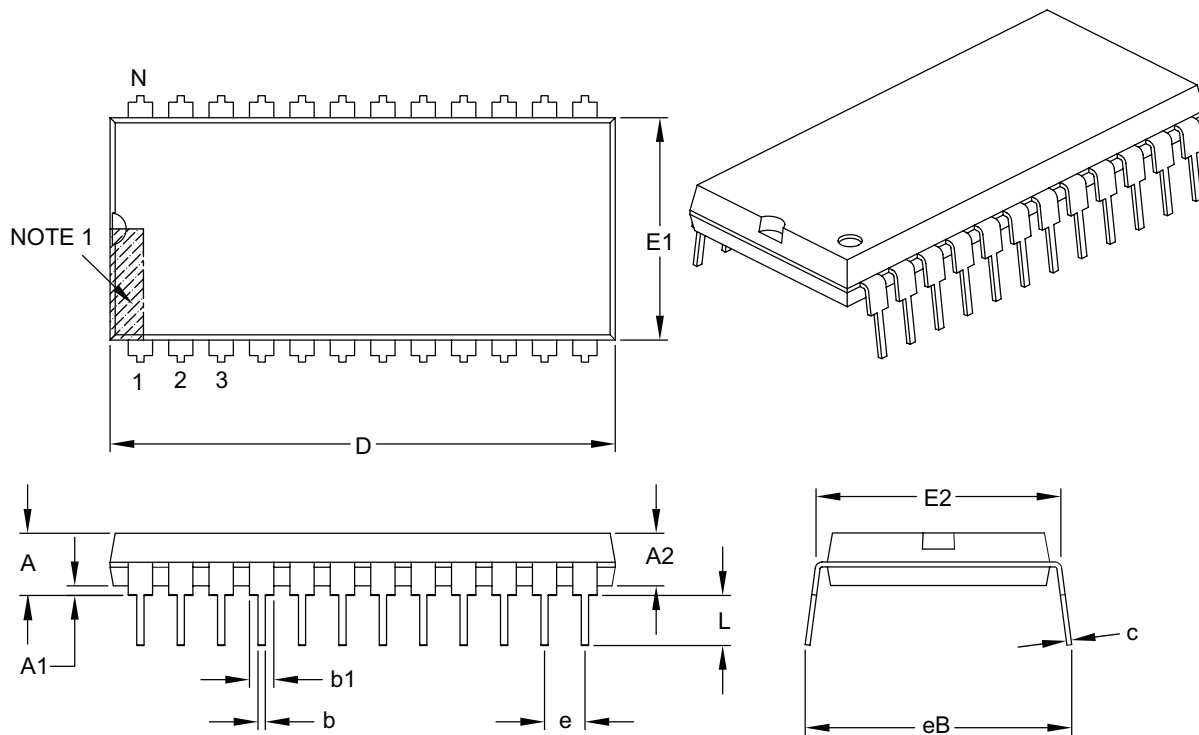

Dimension Limits	Units	INCHES		
		MIN	NOM	MAX
Number of Pins	N	24		
Pitch	e	.100 BSC		
Top to Seating Plane	A	–	–	.250
Molded Package Thickness	A2	.125	–	.195
Base to Seating Plane	A1	.015	–	–
Shoulder to Shoulder Width	E	.590	–	.625
Molded Package Width	E1	.485	–	.580
Overall Length	D	1.150	–	1.290
Tip to Seating Plane	L	.115	–	.200
Lead Thickness	c	.008	–	.015
Upper Lead Width	b1	.030	–	.070
Lower Lead Width	b	.014	–	.022
Overall Row Spacing §	eB	–	–	.700

**Notes:**

1. Pin 1 visual index feature may vary, but must be located within the hatched area.
2. § Significant Characteristic.
3. Dimensions D and E1 do not include mold flash or protrusions. Mold flash or protrusions shall not exceed .010" per side.
4. Dimensioning and tolerancing per ASME Y14.5M.  
BSC: Basic Dimension. Theoretically exact value shown without tolerances.

**Package Outlines and Dimensions**

**28-Lead Plastic Dual In-Line (P) – 600 mil Body [PDIP]**

**Note:** For the most current package drawings, please see the Microchip Packaging Specification located at <http://www.microchip.com/packaging>

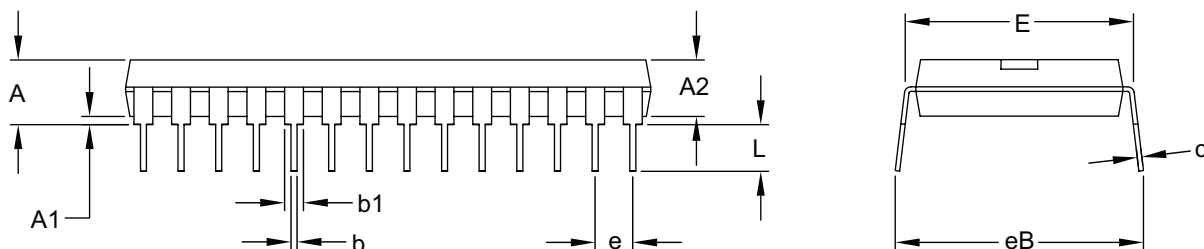
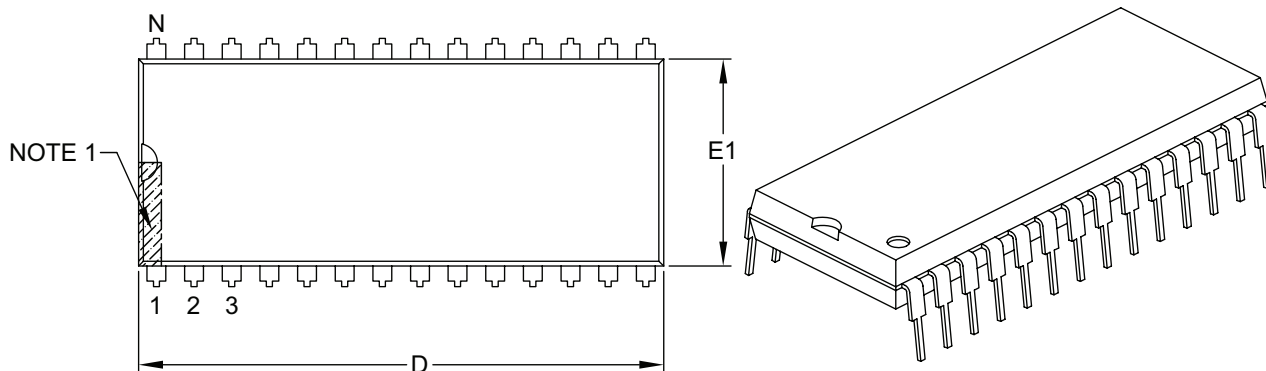

Dimension Limits	Units	INCHES		
		MIN	NOM	MAX
Number of Pins	N	28		
Pitch	e	.100 BSC		
Top to Seating Plane	A	–	–	.250
Molded Package Thickness	A2	.125	–	.195
Base to Seating Plane	A1	.015	–	–
Shoulder to Shoulder Width	E	.590	–	.625
Molded Package Width	E1	.485	–	.580
Overall Length	D	1.380	–	1.565
Tip to Seating Plane	L	.115	–	.200
Lead Thickness	c	.008	–	.015
Upper Lead Width	b1	.030	–	.070
Lower Lead Width	b	.014	–	.022
Overall Row Spacing §	eB	–	–	.700

**Notes:**

- Pin 1 visual index feature may vary, but must be located within the hatched area.
- § Significant Characteristic.
- Dimensions D and E1 do not include mold flash or protrusions. Mold flash or protrusions shall not exceed .010" per side.
- Dimensioning and tolerancing per ASME Y14.5M.  
BSC: Basic Dimension. Theoretically exact value shown without tolerances.



---



---

## Package Outlines and Dimensions

---



---

### 28-Lead Plastic Dual In-Line (PI) – 600 mil Body [PDIP]

**Note:** For the most current package drawings, please see the Microchip Packaging Specification located at <http://www.microchip.com/packaging>

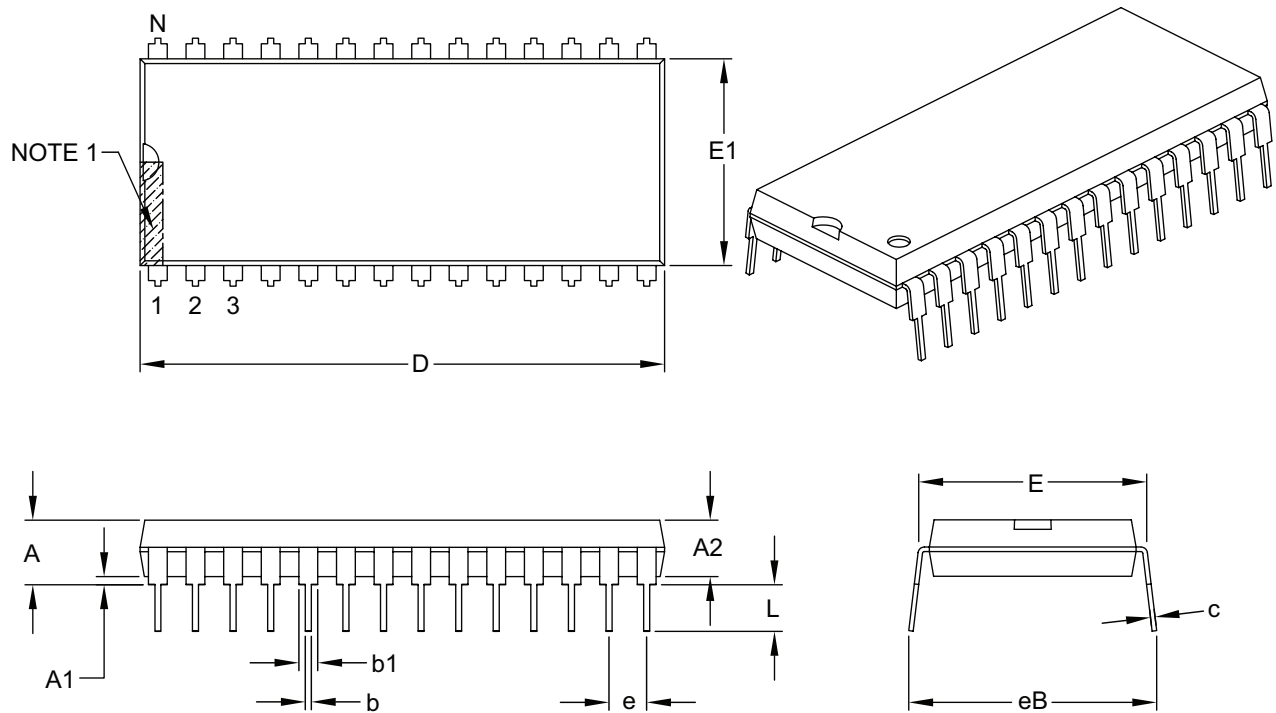

Dimension Limits	Units	INCHES		
		MIN	NOM	MAX
Number of Pins	N	28		
Pitch	e	.100 BSC		
Top to Seating Plane	A	–	–	.250
Molded Package Thickness	A2	.125	–	.195
Base to Seating Plane	A1	.015	–	–
Shoulder to Shoulder Width	E	.590	–	.625
Molded Package Width	E1	.485	–	.580
Overall Length	D	1.380	–	1.565
Tip to Seating Plane	L	.115	–	.200
Lead Thickness	c	.008	–	.015
Upper Lead Width	b1	.030	–	.070
Lower Lead Width	b	.014	–	.022
Overall Row Spacing §	eB	–	–	.700

**Notes:**

1. Pin 1 visual index feature may vary, but must be located within the hatched area.
2. § Significant Characteristic.
3. Dimensions D and E1 do not include mold flash or protrusions. Mold flash or protrusions shall not exceed .010" per side.
4. Dimensioning and tolerancing per ASME Y14.5M.  
BSC: Basic Dimension. Theoretically exact value shown without tolerances.

**Package Outlines and Dimensions**

**40-Lead Plastic Dual In-Line (P) – 600 mil Body [PDIP]**

**Note:** For the most current package drawings, please see the Microchip Packaging Specification located at <http://www.microchip.com/packaging>

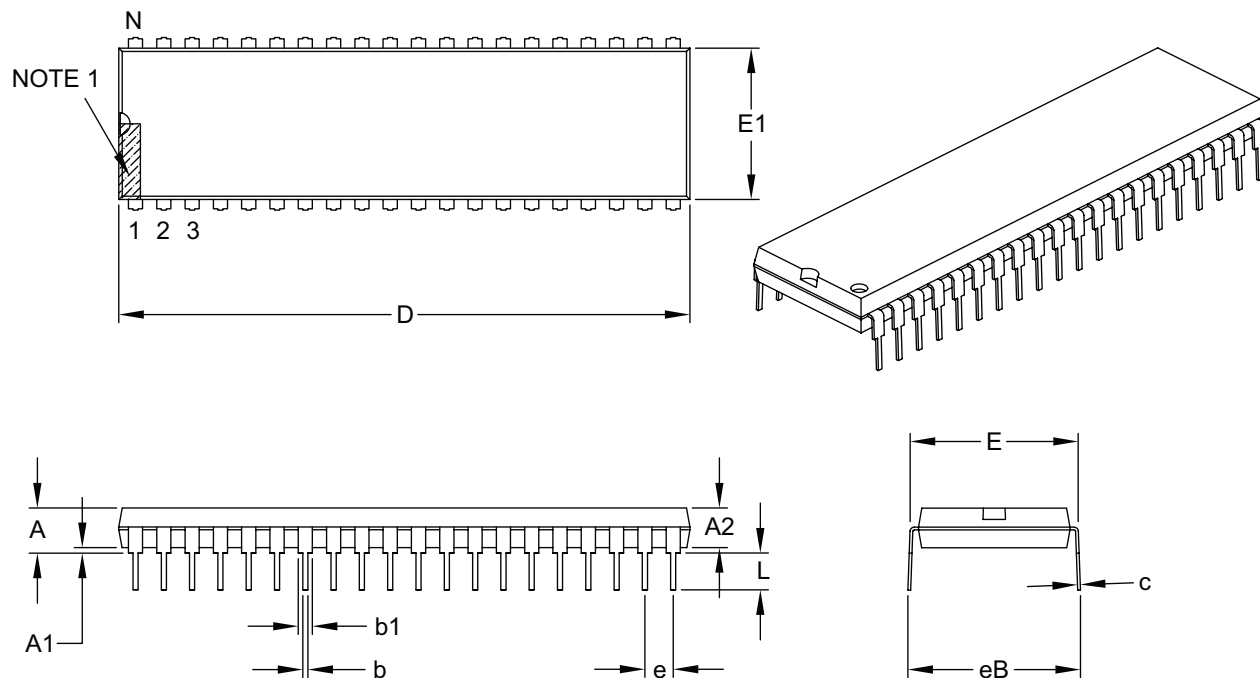

Dimension Limits	Units	INCHES		
		MIN	NOM	MAX
Number of Pins	N	40		
Pitch	e	.100 BSC		
Top to Seating Plane	A	–	–	.250
Molded Package Thickness	A2	.125	–	.195
Base to Seating Plane	A1	.015	–	–
Shoulder to Shoulder Width	E	.590	–	.625
Molded Package Width	E1	.485	–	.580
Overall Length	D	1.980	–	2.095
Tip to Seating Plane	L	.115	–	.200
Lead Thickness	c	.008	–	.015
Upper Lead Width	b1	.030	–	.070
Lower Lead Width	b	.014	–	.023
Overall Row Spacing §	eB	–	–	.700

**Notes:**

- Pin 1 visual index feature may vary, but must be located within the hatched area.
- § Significant Characteristic.
- Dimensions D and E1 do not include mold flash or protrusions. Mold flash or protrusions shall not exceed .010" per side.
- Dimensioning and tolerancing per ASME Y14.5M.  
BSC: Basic Dimension. Theoretically exact value shown without tolerances.

---



---

## Package Outlines and Dimensions

---



---

### 40-Lead Plastic Dual In-Line (PL) – 600 mil Body [PDIP]

**Note:** For the most current package drawings, please see the Microchip Packaging Specification located at <http://www.microchip.com/packaging>

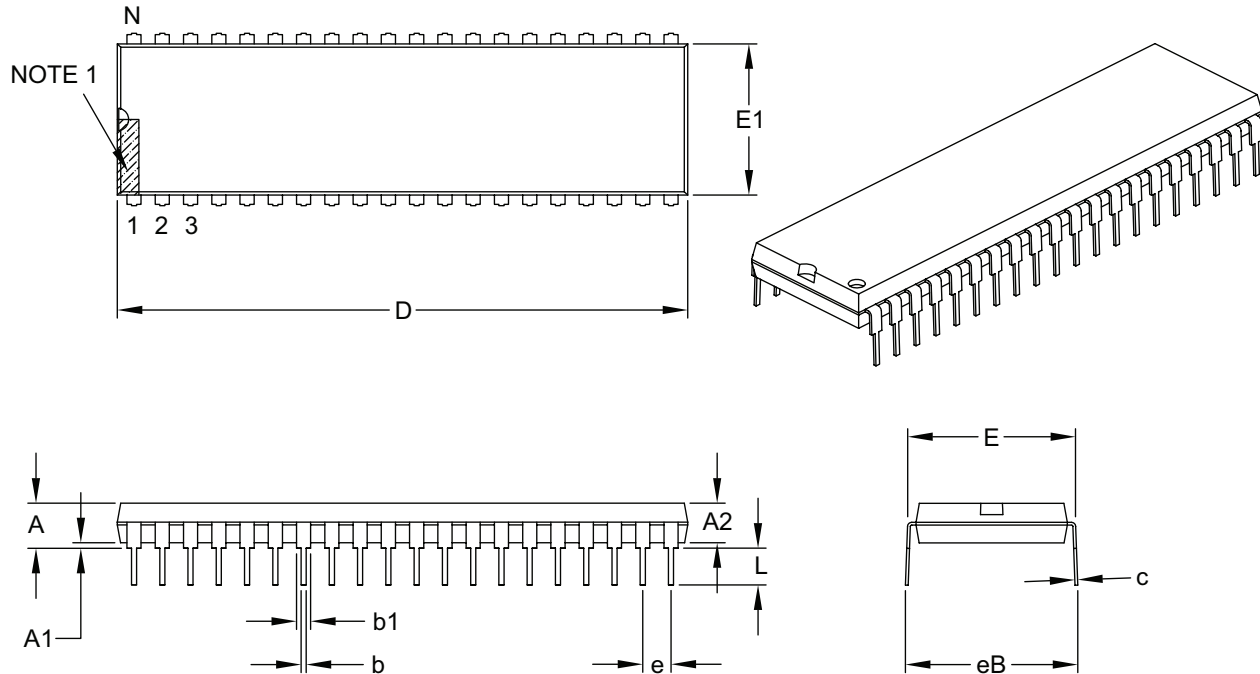

Dimension Limits	Units	INCHES		
		MIN	NOM	MAX
Number of Pins	N	40		
Pitch	e	.100 BSC		
Top to Seating Plane	A	–	–	.250
Molded Package Thickness	A2	.125	–	.195
Base to Seating Plane	A1	.015	–	–
Shoulder to Shoulder Width	E	.590	–	.625
Molded Package Width	E1	.485	–	.580
Overall Length	D	1.980	–	2.095
Tip to Seating Plane	L	.115	–	.200
Lead Thickness	c	.008	–	.015
Upper Lead Width	b1	.030	–	.070
Lower Lead Width	b	.014	–	.023
Overall Row Spacing §	eB	–	–	.700

**Notes:**

1. Pin 1 visual index feature may vary, but must be located within the hatched area.
2. § Significant Characteristic.
3. Dimensions D and E1 do not include mold flash or protrusions. Mold flash or protrusions shall not exceed .010" per side.
4. Dimensioning and tolerancing per ASME Y14.5M.

BSC: Basic Dimension. Theoretically exact value shown without tolerances.

**Package Outlines and Dimensions**

**64-Lead Shrink Plastic Dual In-Line (SP) – 750 mil Body [PDIP]**

**Note:** For the most current package drawings, please see the Microchip Packaging Specification located at <http://www.microchip.com/packaging>

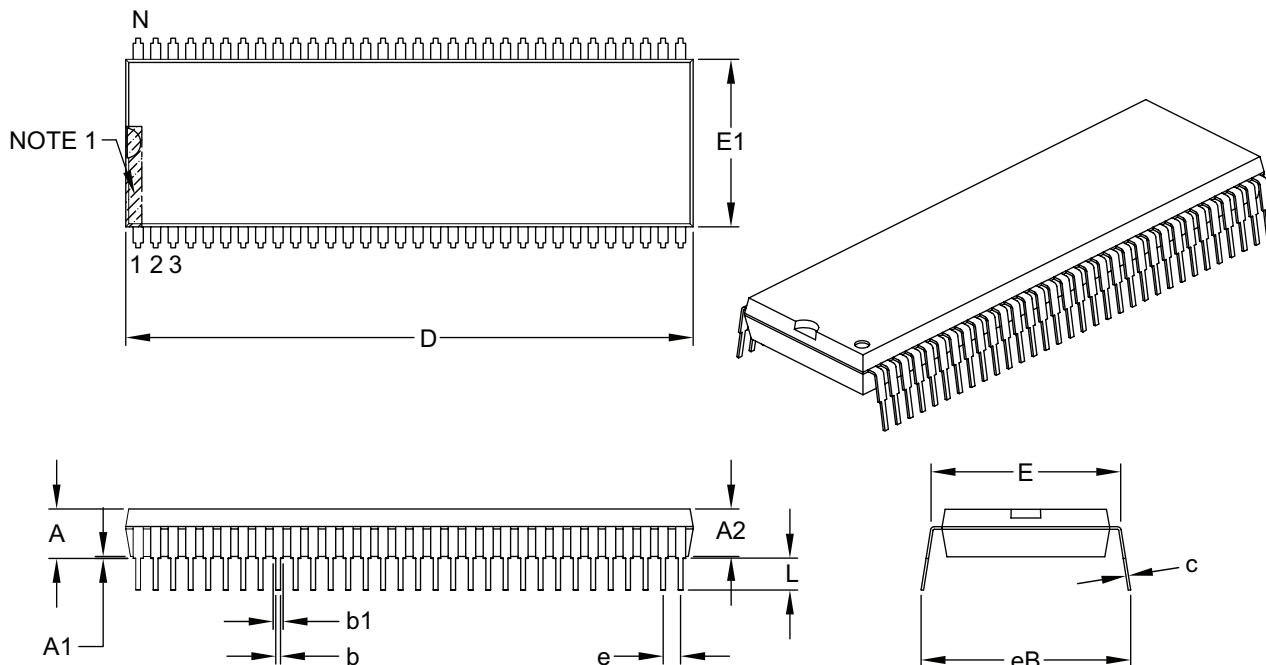

Dimension Limits	Units	INCHES		
		MIN	NOM	MAX
Number of Pins	N	64		
Pitch	e	.070 BSC		
Top to Seating Plane	A	–	–	.200
Molded Package Thickness	A2	.120	.150	.180
Base to Seating Plane	A1	.020	–	–
Shoulder to Shoulder Width	E	.750	–	.785
Molded Package Width	E1	.650	.670	.690
Overall Length	D	2.260	2.270	2.280
Tip to Seating Plane	L	.100	.130	.150
Lead Thickness	c	.009	.010	.015
Upper Lead Width	b1	.035	.040	.045
Lower Lead Width	b	.014	.018	.022
Overall Row Spacing §	eB	–	–	.880

**Notes:**

- Pin 1 visual index feature may vary, but must be located within the hatched area.
- § Significant Characteristic.
- Dimensions D and E1 do not include mold flash or protrusions. Mold flash or protrusions shall not exceed .010" per side.
- Dimensioning and tolerancing per ASME Y14.5M.  
BSC: Basic Dimension. Theoretically exact value shown without tolerances.

---

---

**Package Outlines and Dimensions**

---

---

**SPDIP**

**Package Outlines and Dimensions**

**24-Lead Skinny Plastic Dual In-Line (PF) – 300 mil Body [SPDIP]**

**Note:** For the most current package drawings, please see the Microchip Packaging Specification located at <http://www.microchip.com/packaging>

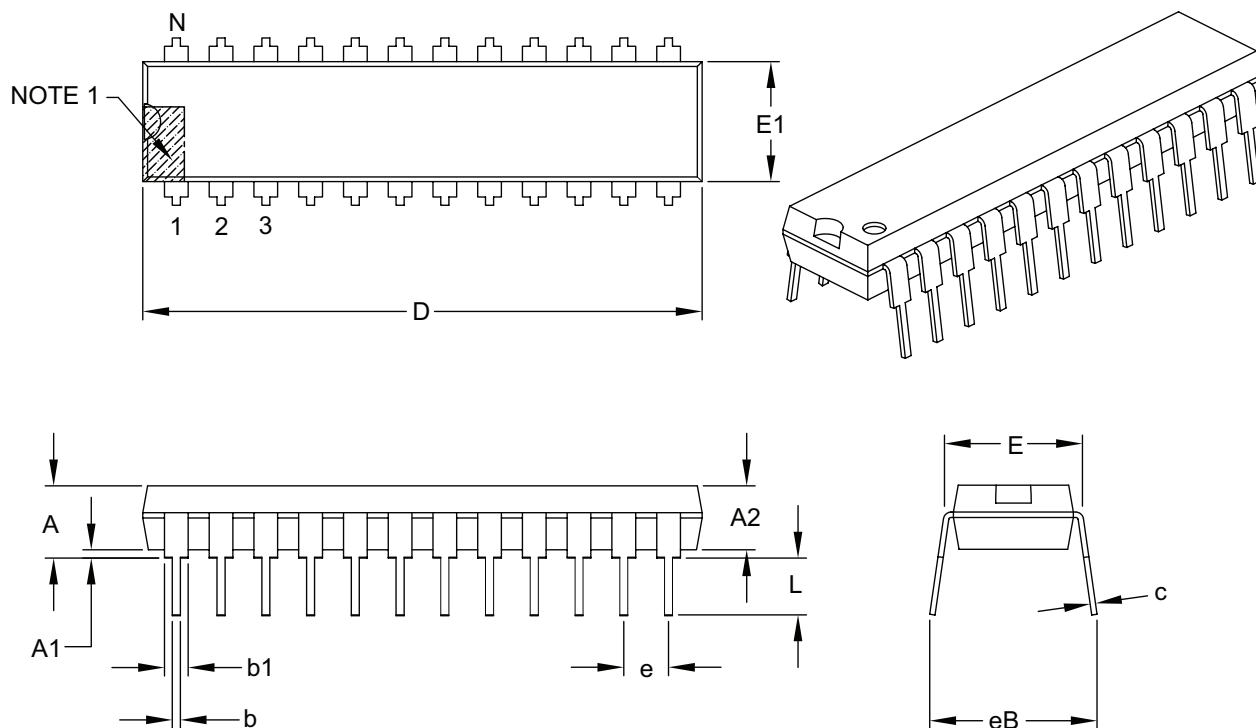

Dimension Limits	Units	INCHES		
		MIN	NOM	MAX
Number of Pins	N	24		
Pitch	e	.100 BSC		
Top to Seating Plane	A	–	–	.210
Molded Package Thickness	A2	.115	.130	.195
Base to Seating Plane	A1	.015	–	–
Shoulder to Shoulder Width	E	.280	.310	.325
Molded Package Width	E1	.240	.250	.280
Overall Length	D	1.155	1.250	1.280
Tip to Seating Plane	L	.115	.130	.160
Lead Thickness	c	.008	.010	.015
Upper Lead Width	b1	.045	.060	.070
Lower Lead Width	b	.014	.018	.023
Overall Row Spacing §	eB	–	–	.430

**Notes:**

- Pin 1 visual index feature may vary, but must be located within the hatched area.
- § Significant Characteristic.
- Dimensions D and E1 do not include mold flash or protrusions. Mold flash or protrusions shall not exceed .010" per side.
- Dimensioning and tolerancing per ASME Y14.5M.  
BSC: Basic Dimension. Theoretically exact value shown without tolerances.

---



---

## Package Outlines and Dimensions

---



---

### 24-Lead Skinny Plastic Dual In-Line (SP) – 300 mil Body [SPDIP]

**Note:** For the most current package drawings, please see the Microchip Packaging Specification located at <http://www.microchip.com/packaging>

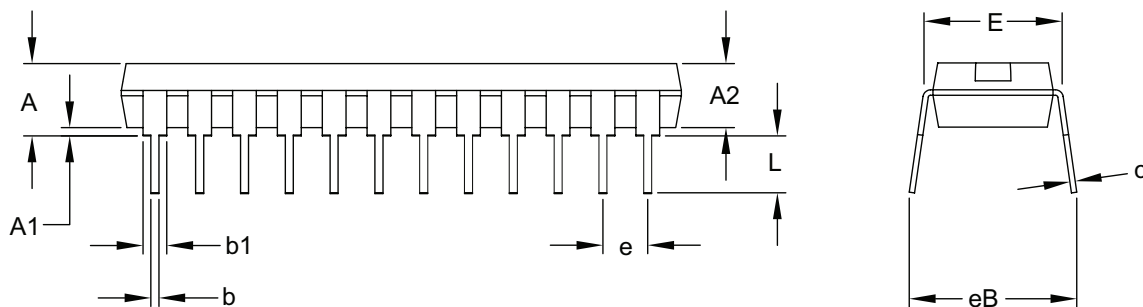
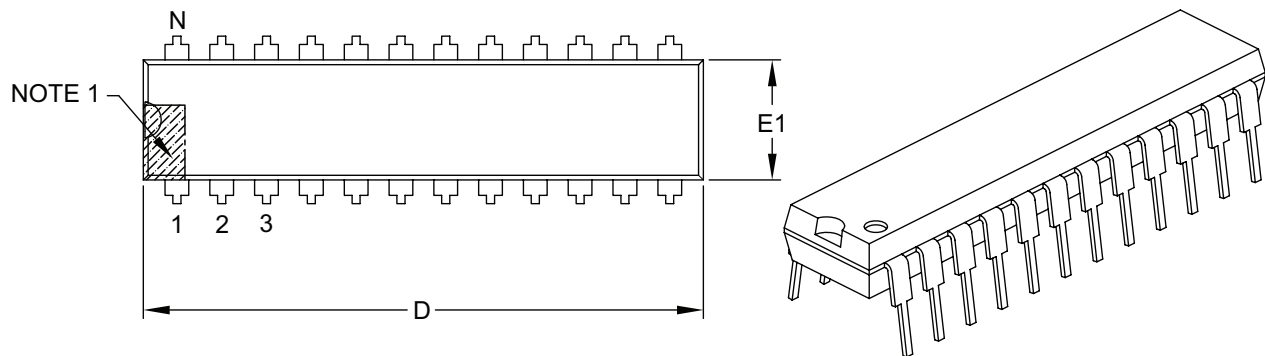

Dimension Limits	Units	INCHES		
		MIN	NOM	MAX
Number of Pins	N	24		
Pitch	e	.100 BSC		
Top to Seating Plane	A	–	–	.210
Molded Package Thickness	A2	.115	.130	.195
Base to Seating Plane	A1	.015	–	–
Shoulder to Shoulder Width	E	.280	.310	.325
Molded Package Width	E1	.240	.250	.280
Overall Length	D	1.155	1.250	1.280
Tip to Seating Plane	L	.115	.130	.160
Lead Thickness	c	.008	.010	.015
Upper Lead Width	b1	.045	.060	.070
Lower Lead Width	b	.014	.018	.023
Overall Row Spacing §	eB	–	–	.430

**Notes:**

1. Pin 1 visual index feature may vary, but must be located within the hatched area.
2. § Significant Characteristic.
3. Dimensions D and E1 do not include mold flash or protrusions. Mold flash or protrusions shall not exceed .010" per side.
4. Dimensioning and tolerancing per ASME Y14.5M.  
BSC: Basic Dimension. Theoretically exact value shown without tolerances.

**Package Outlines and Dimensions**

**28-Lead Skinny Plastic Dual In-Line (PJ) – 300 mil Body [SPDIP]**

**Note:** For the most current package drawings, please see the Microchip Packaging Specification located at <http://www.microchip.com/packaging>

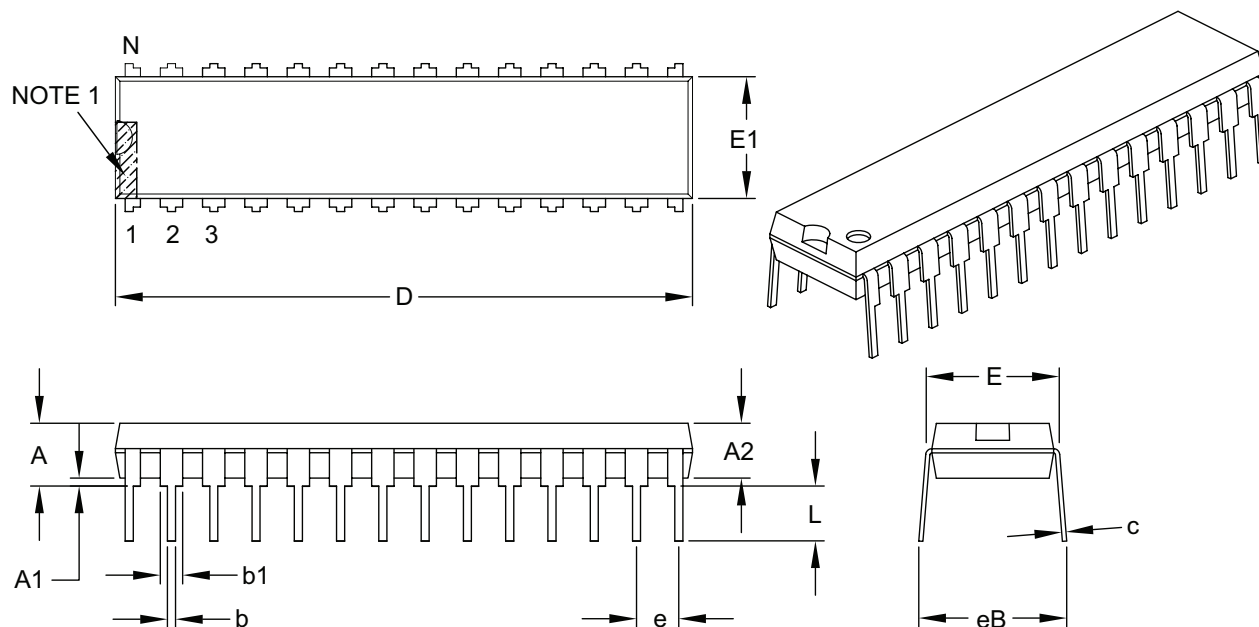

Dimension Limits	Units	INCHES		
		MIN	NOM	MAX
Number of Pins	N	28		
Pitch	e	.100 BSC		
Top to Seating Plane	A	–	–	.200
Molded Package Thickness	A2	.120	.135	.150
Base to Seating Plane	A1	.015	–	–
Shoulder to Shoulder Width	E	.290	.310	.335
Molded Package Width	E1	.240	.285	.295
Overall Length	D	1.345	1.365	1.400
Tip to Seating Plane	L	.110	.130	.150
Lead Thickness	c	.008	.010	.015
Upper Lead Width	b1	.040	.050	.070
Lower Lead Width	b	.014	.018	.022
Overall Row Spacing §	eB	–	–	.430

**Notes:**

- Pin 1 visual index feature may vary, but must be located within the hatched area.
- § Significant Characteristic.
- Dimensions D and E1 do not include mold flash or protrusions. Mold flash or protrusions shall not exceed .010" per side.
- Dimensioning and tolerancing per ASME Y14.5M.  
BSC: Basic Dimension. Theoretically exact value shown without tolerances.



---



---

## Package Outlines and Dimensions

---



---

### 28-Lead Skinny Plastic Dual In-Line (SP) – 300 mil Body [SPDIP]

**Note:** For the most current package drawings, please see the Microchip Packaging Specification located at <http://www.microchip.com/packaging>

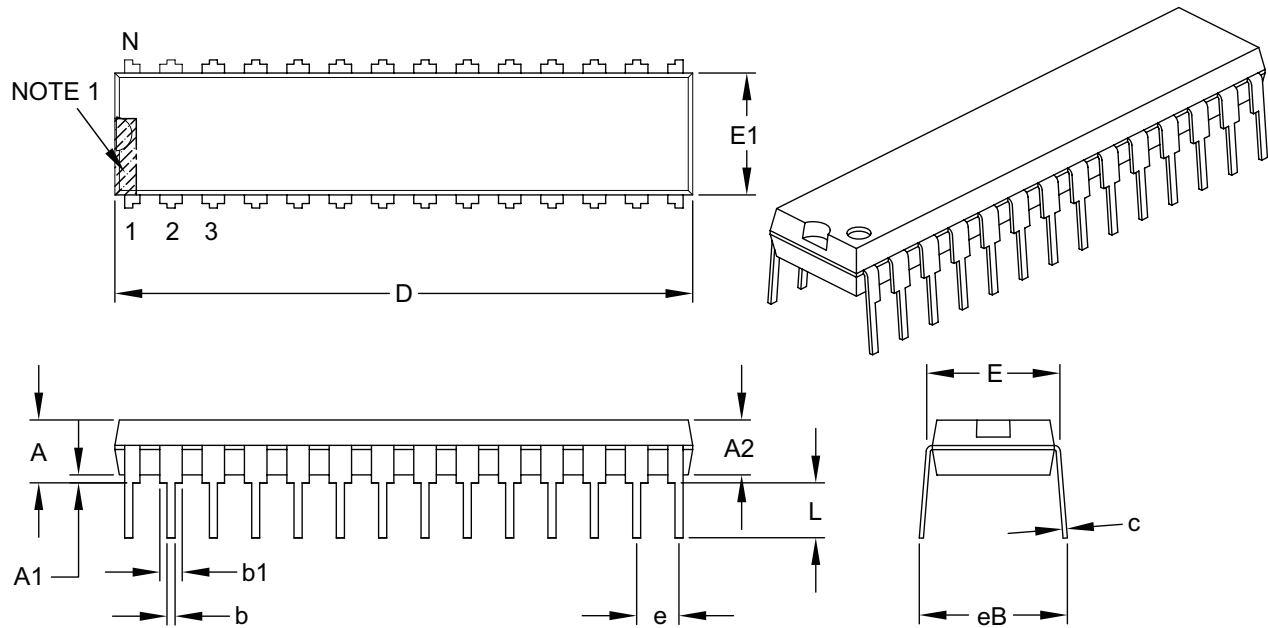

	Units	INCHES		
		MIN	NOM	MAX
Number of Pins	N	28		
Pitch	e	.100 BSC		
Top to Seating Plane	A	–	–	.200
Molded Package Thickness	A2	.120	.135	.150
Base to Seating Plane	A1	.015	–	–
Shoulder to Shoulder Width	E	.290	.310	.335
Molded Package Width	E1	.240	.285	.295
Overall Length	D	1.345	1.365	1.400
Tip to Seating Plane	L	.110	.130	.150
Lead Thickness	c	.008	.010	.015
Upper Lead Width	b1	.040	.050	.070
Lower Lead Width	b	.014	.018	.022
Overall Row Spacing §	eB	–	–	.430

**Notes:**

1. Pin 1 visual index feature may vary, but must be located within the hatched area.
2. § Significant Characteristic.
3. Dimensions D and E1 do not include mold flash or protrusions. Mold flash or protrusions shall not exceed .010" per side.
4. Dimensioning and tolerancing per ASME Y14.5M.  
BSC: Basic Dimension. Theoretically exact value shown without tolerances.



**MICROCHIP**

---

---

**Package Outlines and Dimensions**

---

---

NOTES:

---

---

**Package Outlines and Dimensions**

---

---

**PLCC**

**Package Outlines and Dimensions**

**20-Lead Plastic Leaded Chip Carrier (L) – Square [PLCC]**

**Note:** For the most current package drawings, please see the Microchip Packaging Specification located at <http://www.microchip.com/packaging>

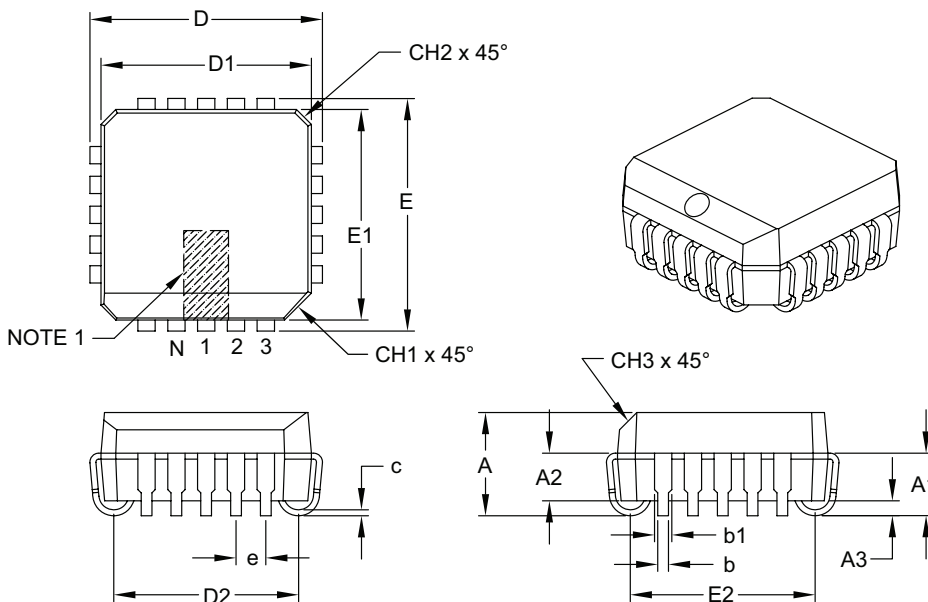

Dimension Limits	Units	INCHES		
		MIN	NOM	MAX
Number of Pins	N	20		
Pitch	e	.050		
Overall Height	A	.165	.172	.180
Contact Height	A1	.090	.105	.120
Molded Package to Contact	A2	.062	–	.083
Standoff §	A3	.020	–	–
Corner Chamfer	CH1	.042	–	.048
Chamfers	CH2	–	–	.020
Side Chamfer	CH3	.042	–	.056
Overall Width	E	.385	.390	.395
Overall Length	D	.385	.390	.395
Molded Package Width	E1	.350	.353	.356
Molded Package Length	D1	.350	.353	.356
Footprint Width	E2	.282	.310	.338
Footprint Length	D2	.282	.310	.338
Lead Thickness	c	.0075	–	.0125
Upper Lead Width	b1	.026	–	.032
Lower Lead Width	b	.013	–	.021

**Notes:**

- Pin 1 visual index feature may vary, but must be located within the hatched area.
- § Significant Characteristic.
- Dimensions D1 and E1 do not include mold flash or protrusions. Mold flash or protrusions shall not exceed .010" per side.
- Dimensioning and tolerancing per ASME Y14.5M.

---



---

## Footprint Outlines and Dimensions

---



---

### 20-Lead Plastic Leaded Chip Carrier (L) - Square [PLCC]

**Note:** For the most current package drawings, please see the Microchip Packaging Specification located at <http://www.microchip.com/packaging>

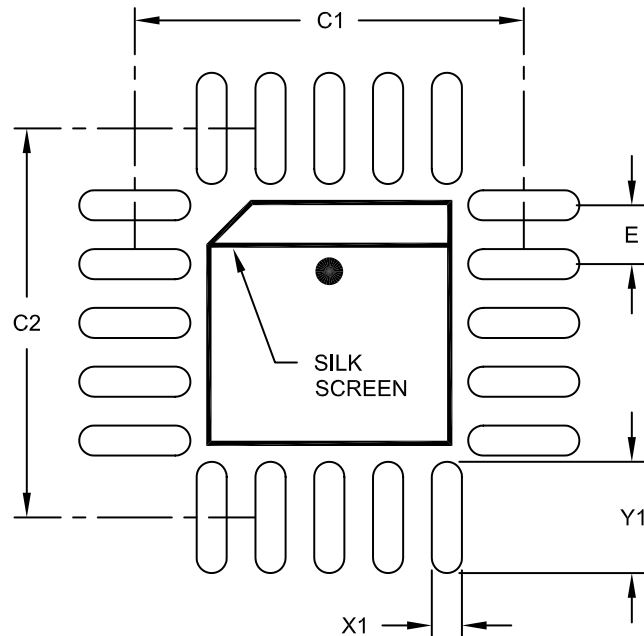

**RECOMMENDED LAND PATTERN**

		Units	INCHES		
Dimension Limits			MIN	NOM	MAX
Contact Pitch	E		.050 BSC		
Contact Pad Spacing	C1			.331	
Contact Pad Spacing	C2			.331	
Contact Pad Width (X20)	X1				.026
Contact Pad Length (X20)	Y1				.094

**Notes:**

1. Dimensioning and tolerancing per ASME Y14.5M

BSC: Basic Dimension. Theoretically exact value shown without tolerances.

Microchip Technology Drawing No. C04-2064A

**Package Outlines and Dimensions**

**28-Lead Plastic Leaded Chip Carrier (L) – Square [PLCC]**

**Note:** For the most current package drawings, please see the Microchip Packaging Specification located at <http://www.microchip.com/packaging>

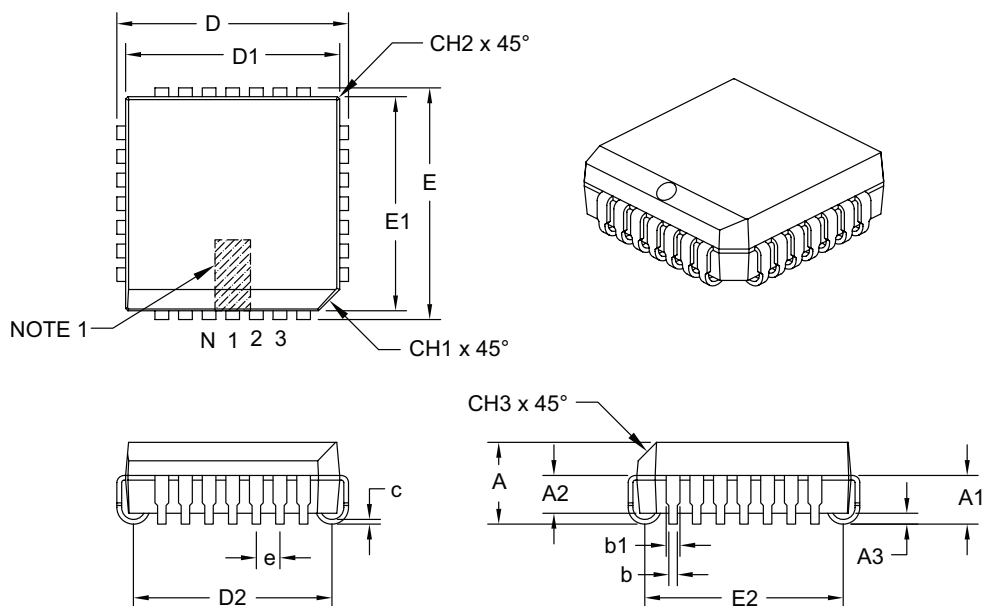

Dimension Limits	Units	INCHES		
		MIN	NOM	MAX
Number of Pins	N	28		
Pitch	e	.050		
Overall Height	A	.165	.172	.180
Contact Height	A1	.090	.105	.120
Molded Package to Contact	A2	.062	–	.083
Standoff §	A3	.020	–	–
Corner Chamfer	CH1	.042	–	.048
Chamfers	CH2	–	–	.020
Side Chamfer	CH3	.042	–	.056
Overall Width	E	.485	.490	.495
Overall Length	D	.485	.490	.495
Molded Package Width	E1	.450	.453	.456
Molded Package Length	D1	.450	.453	.456
Footprint Width	E2	.382	.410	.438
Footprint Length	D2	.382	.410	.438
Lead Thickness	c	.0075	–	.0125
Upper Lead Width	b1	.026	–	.032
Lower Lead Width	b	.013	–	.021

**Notes:**

- Pin 1 visual index feature may vary, but must be located within the hatched area.
- § Significant Characteristic.
- Dimensions D1 and E1 do not include mold flash or protrusions. Mold flash or protrusions shall not exceed .010" per side.
- Dimensioning and tolerancing per ASME Y14.5M.

---



---

## Footprint Outlines and Dimensions

---



---

### 28-Lead Plastic Leaded Chip Carrier (L) - Square [PLCC]

**Note:** For the most current package drawings, please see the Microchip Packaging Specification located at <http://www.microchip.com/packaging>

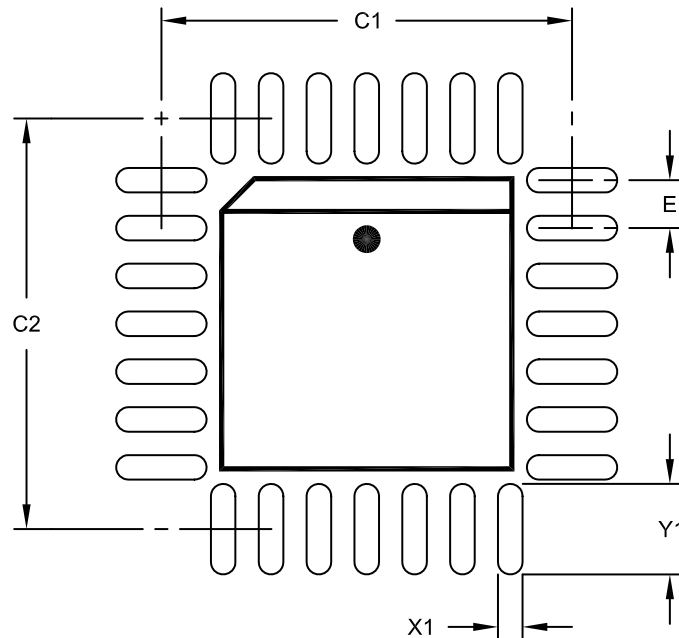

**RECOMMENDED LAND PATTERN**

		Units	INCHES		
Dimension Limits			MIN	NOM	MAX
Contact Pitch	E		.050 BSC		
Contact Pad Spacing	C1			.429	
Contact Pad Spacing	C2			.429	
Contact Pad Width (X28)	X1				.026
Contact Pad Length (X28)	Y1				.094

**Notes:**

1. Dimensioning and tolerancing per ASME Y14.5M

BSC: Basic Dimension. Theoretically exact value shown without tolerances.

Microchip Technology Drawing No. C04-2026A

**Package Outlines and Dimensions**

**28-Lead Plastic Leaded Chip Carrier (LI) – Square [PLCC]**

**Note:** For the most current package drawings, please see the Microchip Packaging Specification located at <http://www.microchip.com/packaging>

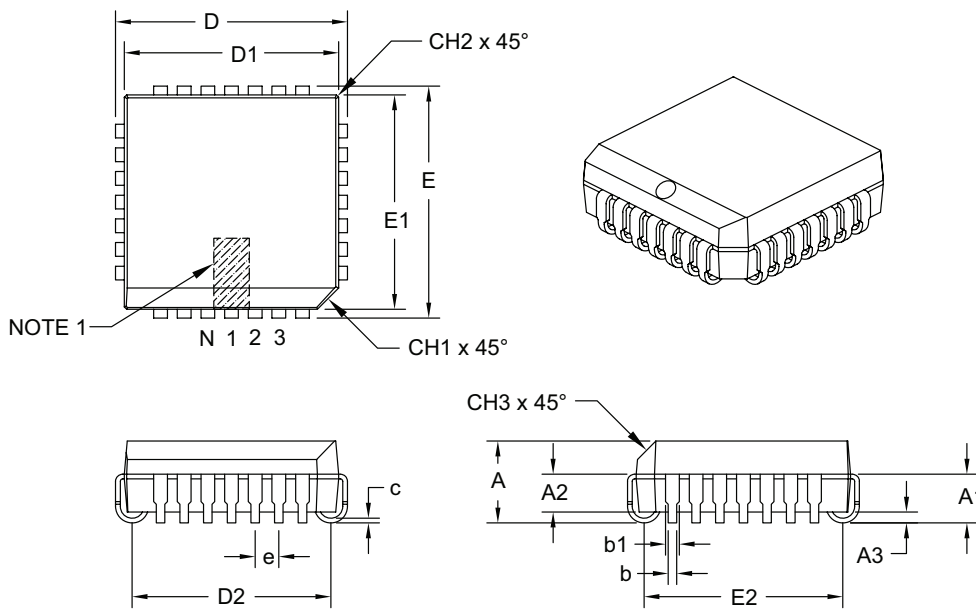

Dimension Limits	Units	INCHES		
		MIN	NOM	MAX
Number of Pins	N	28		
Pitch	e	.050		
Overall Height	A	.165	.172	.180
Contact Height	A1	.090	.105	.120
Molded Package to Contact	A2	.062	–	.083
Standoff §	A3	.020	–	–
Corner Chamfer	CH1	.042	–	.048
Chamfers	CH2	–	–	.020
Side Chamfer	CH3	.042	–	.056
Overall Width	E	.485	.490	.495
Overall Length	D	.485	.490	.495
Molded Package Width	E1	.450	.453	.456
Molded Package Length	D1	.450	.453	.456
Footprint Width	E2	.382	.410	.438
Footprint Length	D2	.382	.410	.438
Lead Thickness	c	.0075	–	.0125
Upper Lead Width	b1	.026	–	.032
Lower Lead Width	b	.013	–	.021

**Notes:**

- Pin 1 visual index feature may vary, but must be located within the hatched area.
- § Significant Characteristic.
- Dimensions D1 and E1 do not include mold flash or protrusions. Mold flash or protrusions shall not exceed .010" per side.
- Dimensioning and tolerancing per ASME Y14.5M.



---



---

## Footprint Outlines and Dimensions

---



---

### 28-Lead Plastic Leaded Chip Carrier (LI) - Square [PLCC]

**Note:** For the most current package drawings, please see the Microchip Packaging Specification located at <http://www.microchip.com/packaging>

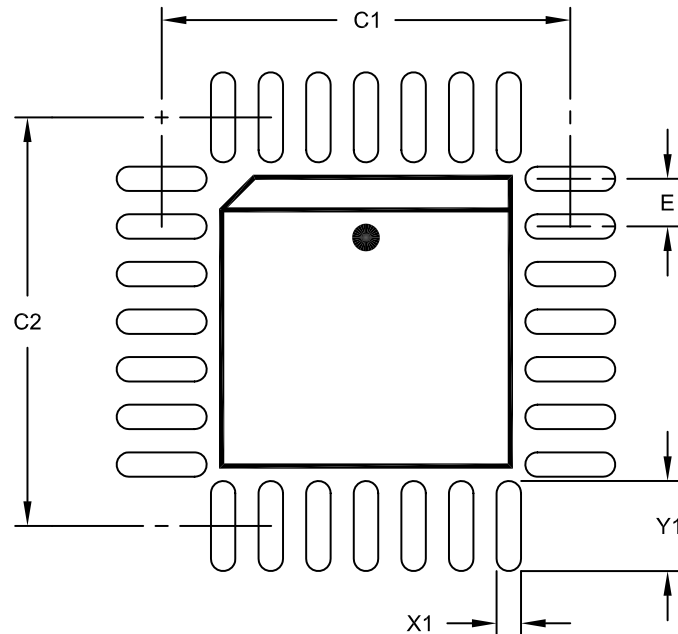

**RECOMMENDED LAND PATTERN**

		Units	INCHES		
Dimension Limits			MIN	NOM	MAX
Contact Pitch	E		.050 BSC		
Contact Pad Spacing	C1			.429	
Contact Pad Spacing	C2			.429	
Contact Pad Width (X28)	X1				.026
Contact Pad Length (X28)	Y1				.094

**Notes:**

1. Dimensioning and tolerancing per ASME Y14.5M

BSC: Basic Dimension. Theoretically exact value shown without tolerances.

Microchip Technology Drawing No. C04-2026A

**Package Outlines and Dimensions**

**32-Lead Plastic Leaded Chip Carrier (L) – Rectangle [PLCC]**

**Note:** For the most current package drawings, please see the Microchip Packaging Specification located at <http://www.microchip.com/packaging>

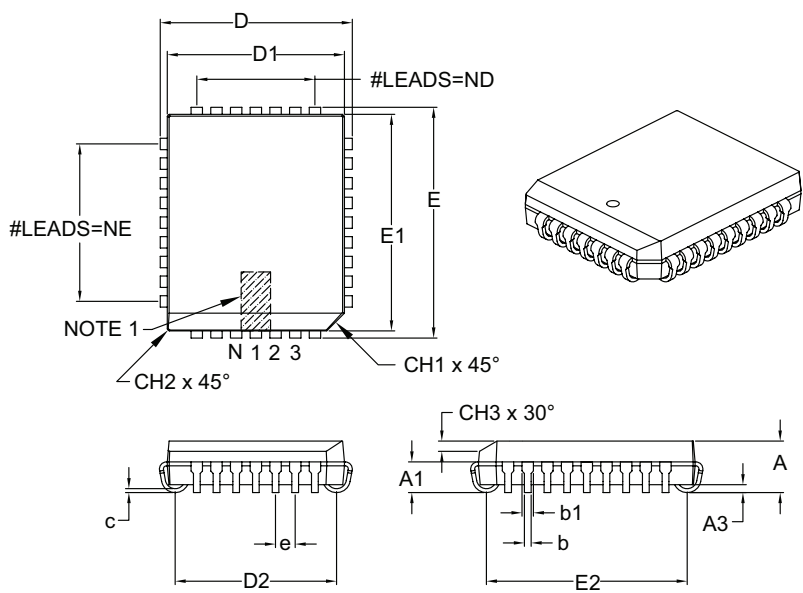

Dimension Limits	Units	INCHES		
		MIN	NOM	MAX
Number of Pins	N	32		
Pitch	e	.050		
Pins along Length	ND	7		
Pins along Width	NE	9		
Overall Height	A	.125	–	.140
Contact Height	A1	.060	–	.095
Standoff §	A3	.015	–	–
Corner Chamfer	CH1	.042	–	.048
Chamfers	CH2	–	–	.020
Side Chamfer Height	CH3	.023	–	.029
Overall Length	D	.485	–	.495
Overall Width	E	.585	–	.595
Molded Package Length	D1	.447	–	.453
Molded Package Width	E1	.547	–	.553
Footprint Length	D2	.376	–	.446
Footprint Width	E2	.476	–	.546
Lead Thickness	c	.008	–	.013
Upper Lead Width	b1	.026	–	.032
Lower Lead Width	b	.013	–	.021

**Notes:**

- Pin 1 visual index feature may vary, but must be located within the hatched area.
- § Significant Characteristic.
- Dimensions D1 and E1 do not include mold flash or protrusions. Mold flash or protrusions shall not exceed .010" per side.
- Dimensioning and tolerancing per ASME Y14.5M.

---



---

## Footprint Outlines and Dimensions

---



---

### 32-Lead Plastic Leaded Chip Carrier (L) - Rectangle [PLCC]

**Note:** For the most current package drawings, please see the Microchip Packaging Specification located at <http://www.microchip.com/packaging>

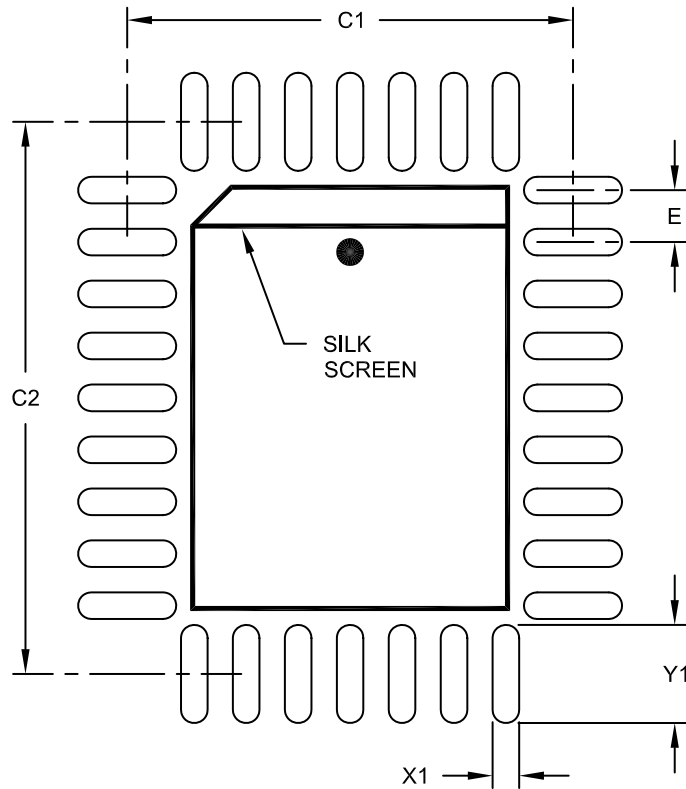

### RECOMMENDED LAND PATTERN

		Units	INCHES		
Dimension Limits			MIN	NOM	MAX
Contact Pitch	E		.050 BSC		
Contact Pad Spacing	C1			.429	
Contact Pad Spacing	C2			.531	
Contact Pad Width (X32)	X1				.026
Contact Pad Length (X32)	Y1				.094

**Notes:**

1. Dimensioning and tolerancing per ASME Y14.5M

BSC: Basic Dimension. Theoretically exact value shown without tolerances.

Microchip Technology Drawing No. C04-2023A

**Package Outlines and Dimensions**

**44-Lead Plastic Leaded Chip Carrier (L) – Square [PLCC]**

**Note:** For the most current package drawings, please see the Microchip Packaging Specification located at <http://www.microchip.com/packaging>

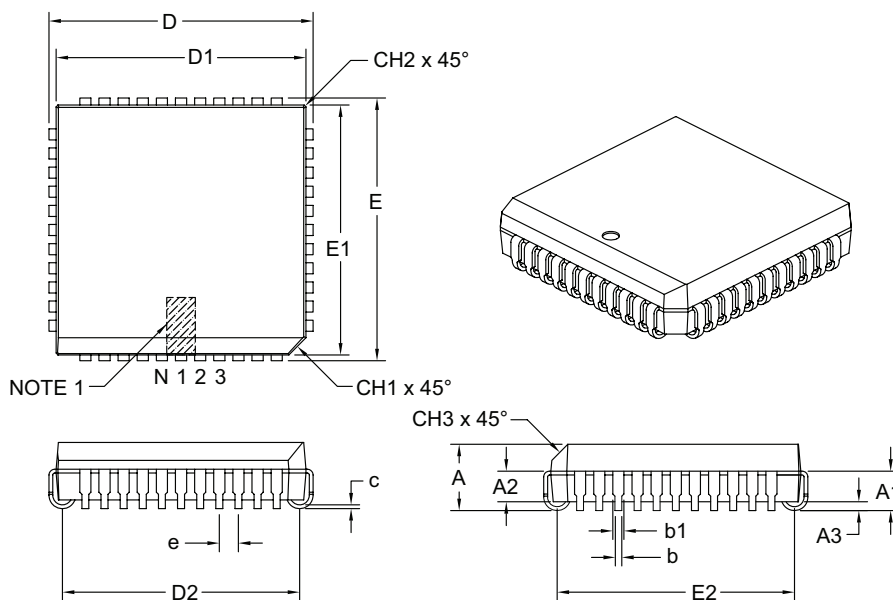

Dimension Limits	Units	INCHES		
		MIN	NOM	MAX
Number of Pins	N	44		
Pitch	e	.050		
Overall Height	A	.165	.172	.180
Contact Height	A1	.090	.105	.120
Molded Package to Contact	A2	.062	–	.083
Standoff §	A3	.020	–	–
Corner Chamfer	CH1	.042	–	.048
Chamfers	CH2	–	–	.020
Side Chamfer	CH3	.042	–	.056
Overall Width	E	.685	.690	.695
Overall Length	D	.685	.690	.695
Molded Package Width	E1	.650	.653	.656
Molded Package Length	D1	.650	.653	.656
Footprint Width	E2	.582	.610	.638
Footprint Length	D2	.582	.610	.638
Lead Thickness	c	.0075	–	.0125
Upper Lead Width	b1	.026	–	.032
Lower Lead Width	b	.013	–	.021

**Notes:**

- Pin 1 visual index feature may vary, but must be located within the hatched area.
- § Significant Characteristic.
- Dimensions D1 and E1 do not include mold flash or protrusions. Mold flash or protrusions shall not exceed .010" per side.
- Dimensioning and tolerancing per ASME Y14.5M.

---



---

## Footprint Outlines and Dimensions

---



---

### 44-Lead Plastic Leaded Chip Carrier (L) - Square [PLCC]

**Note:** For the most current package drawings, please see the Microchip Packaging Specification located at <http://www.microchip.com/packaging>

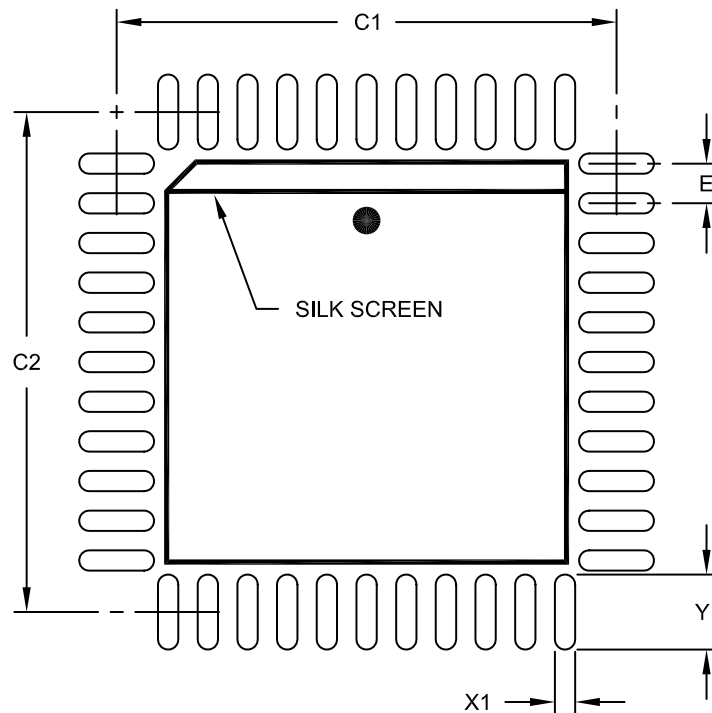

Dimension	Units Limits	INCHES		
		MIN	NOM	MAX
Contact Pitch	E		.050 BSC	
Contact Pad Spacing	C1		.630	
Contact Pad Spacing	C2		.630	
Contact Pad Width (X44)	X1			.026
Contact Pad Length (X44)	Y1			.094

**Notes:**

1. Dimensioning and tolerancing per ASME Y14.5M

BSC: Basic Dimension. Theoretically exact value shown without tolerances.

Microchip Technology Drawing No. C04-2048A

**Package Outlines and Dimensions**

**44-Lead Plastic Leaded Chip Carrier (LW) – Square [PLCC]**

**Note:** For the most current package drawings, please see the Microchip Packaging Specification located at <http://www.microchip.com/packaging>

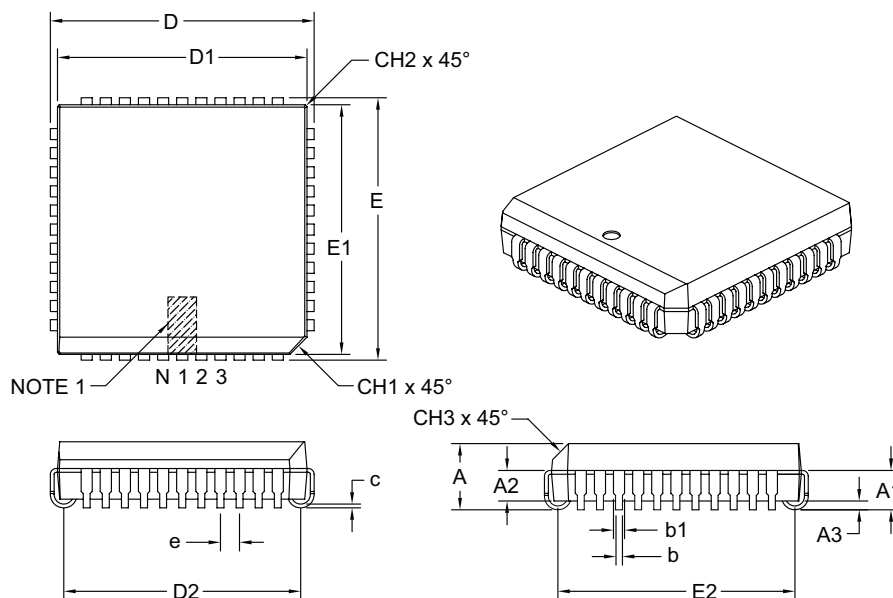

Dimension Limits	Units	INCHES		
		MIN	NOM	MAX
Number of Pins	N	44		
Pitch	e	.050		
Overall Height	A	.165	.172	.180
Contact Height	A1	.090	.105	.120
Molded Package to Contact	A2	.062	–	.083
Standoff §	A3	.020	–	–
Corner Chamfer	CH1	.042	–	.048
Chamfers	CH2	–	–	.020
Side Chamfer	CH3	.042	–	.056
Overall Width	E	.685	.690	.695
Overall Length	D	.685	.690	.695
Molded Package Width	E1	.650	.653	.656
Molded Package Length	D1	.650	.653	.656
Footprint Width	E2	.582	.610	.638
Footprint Length	D2	.582	.610	.638
Lead Thickness	c	.0075	–	.0125
Upper Lead Width	b1	.026	–	.032
Lower Lead Width	b	.013	–	.021

**Notes:**

- Pin 1 visual index feature may vary, but must be located within the hatched area.
- § Significant Characteristic.
- Dimensions D1 and E1 do not include mold flash or protrusions. Mold flash or protrusions shall not exceed .010" per side.
- Dimensioning and tolerancing per ASME Y14.5M.

---



---

## Footprint Outlines and Dimensions

---



---

### 44-Lead Plastic Leaded Chip Carrier (LW) – Square [PLCC]

**Note:** For the most current package drawings, please see the Microchip Packaging Specification located at <http://www.microchip.com/packaging>

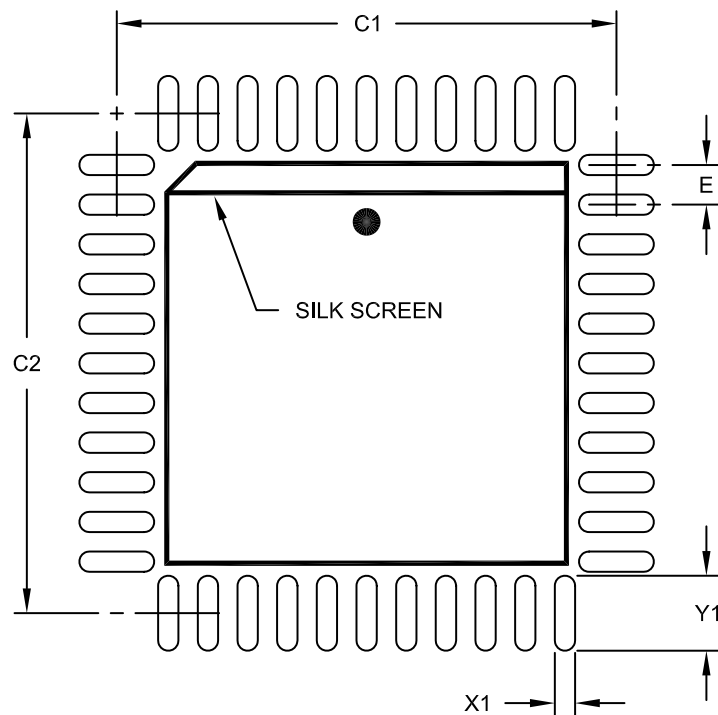

**RECOMMENDED LAND PATTERN**

Dimension	Units Limits	INCHES		
		MIN	NOM	MAX
Contact Pitch	E		.050 BSC	
Contact Pad Spacing	C1		.630	
Contact Pad Spacing	C2		.630	
Contact Pad Width (X44)	X1			.026
Contact Pad Length (X44)	Y1			.094

**Notes:**

1. Dimensioning and tolerancing per ASME Y14.5M

BSC: Basic Dimension. Theoretically exact value shown without tolerances.

Microchip Technology Drawing No. C04-2048A

**Package Outlines and Dimensions**

**68-Lead Plastic Leaded Chip Carrier (L) – Square [PLCC]**

**Note:** For the most current package drawings, please see the Microchip Packaging Specification located at <http://www.microchip.com/packaging>

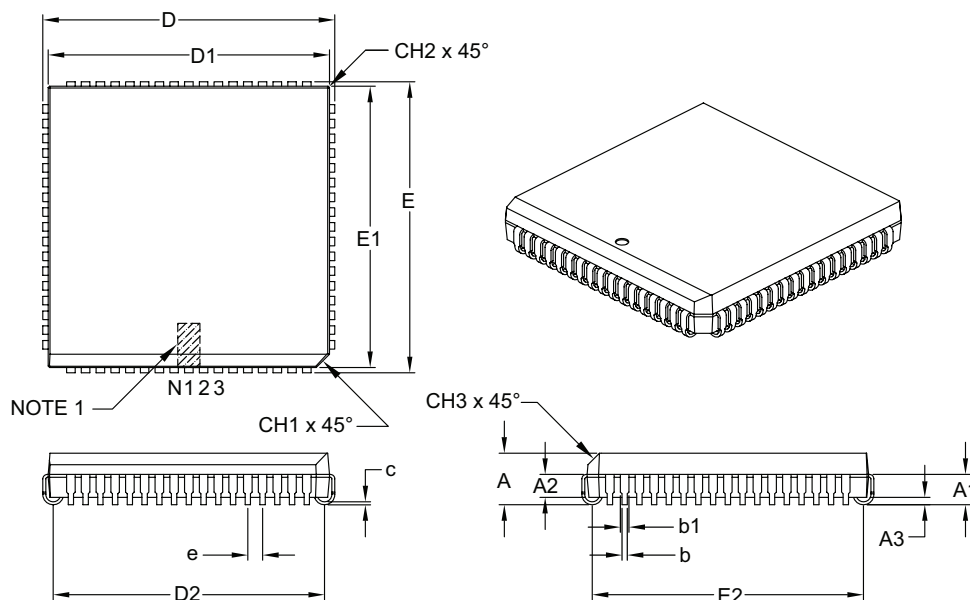

Dimension Limits	Units	INCHES		
		MIN	NOM	MAX
Number of Pins	N	68		
Pitch	e	.050		
Overall Height	A	.165	.172	.180
Contact Height	A1	.090	.105	.120
Molded Package to Contact	A2	.062	–	.083
Standoff §	A3	.020	–	–
Corner Chamfer	CH1	.042	–	.048
Chamfers	CH2	–	–	.020
Side Chamfer	CH3	.042	–	.056
Overall Width	E	.985	.990	.995
Overall Length	D	.985	.990	.995
Molded Package Width	E1	.950	.954	.958
Molded Package Length	D1	.950	.954	.958
Footprint Width	E2	.882	.910	.938
Footprint Length	D2	.882	.910	.938
Lead Thickness	c	.0075	–	.0125
Upper Lead Width	b1	.026	–	.032
Lower Lead Width	b	.013	–	.021

**Notes:**

- Pin 1 visual index feature may vary, but must be located within the hatched area.
- § Significant Characteristic.
- Dimensions D1 and E1 do not include mold flash or protrusions. Mold flash or protrusions shall not exceed .010" per side.
- Dimensioning and tolerancing per ASME Y14.5M.

Microchip Technology Drawing C04-049B



---



---

## Footprint Outlines and Dimensions

---



---

### 68-Lead Plastic Leaded Chip Carrier (L) - Square [PLCC]

**Note:** For the most current package drawings, please see the Microchip Packaging Specification located at <http://www.microchip.com/packaging>

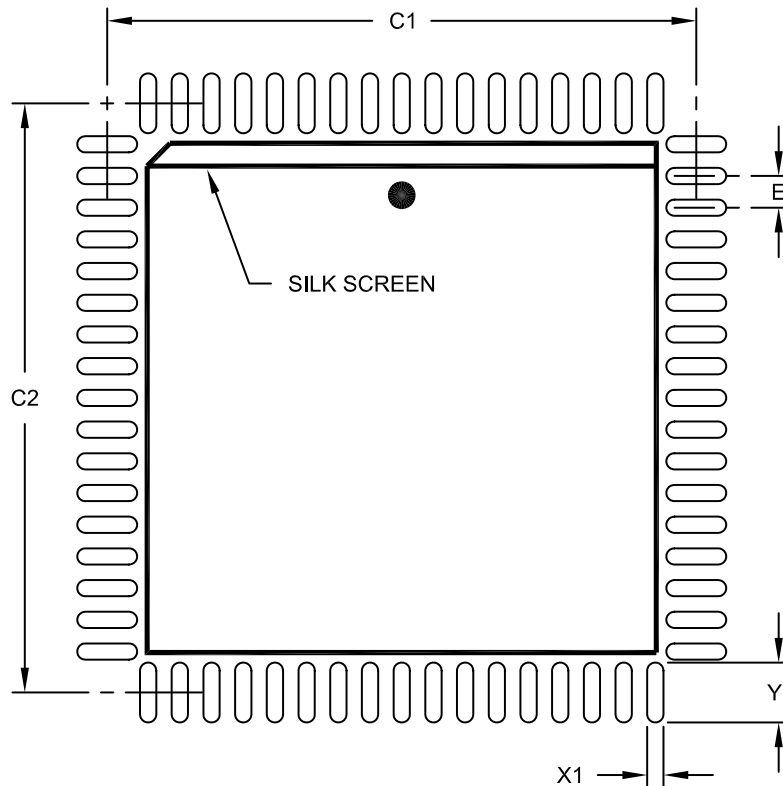

### RECOMMENDED LAND PATTERN

		Units	INCHES		
Dimension Limits			MIN	NOM	MAX
Contact Pitch	E		.050 BSC		
Contact Pad Spacing	C1			.929	
Contact Pad Spacing	C2			.929	
Contact Pad Width (X68)	X1				.026
Contact Pad Length (X68)	Y1				.094

**Notes:**

1. Dimensioning and tolerancing per ASME Y14.5M

BSC: Basic Dimension. Theoretically exact value shown without tolerances.

Microchip Technology Drawing No. C04-2049A

**Package Outlines and Dimensions**

**68-Lead Plastic Leaded Chip Carrier (LS) – Square [PLCC]**

**Note:** For the most current package drawings, please see the Microchip Packaging Specification located at <http://www.microchip.com/packaging>

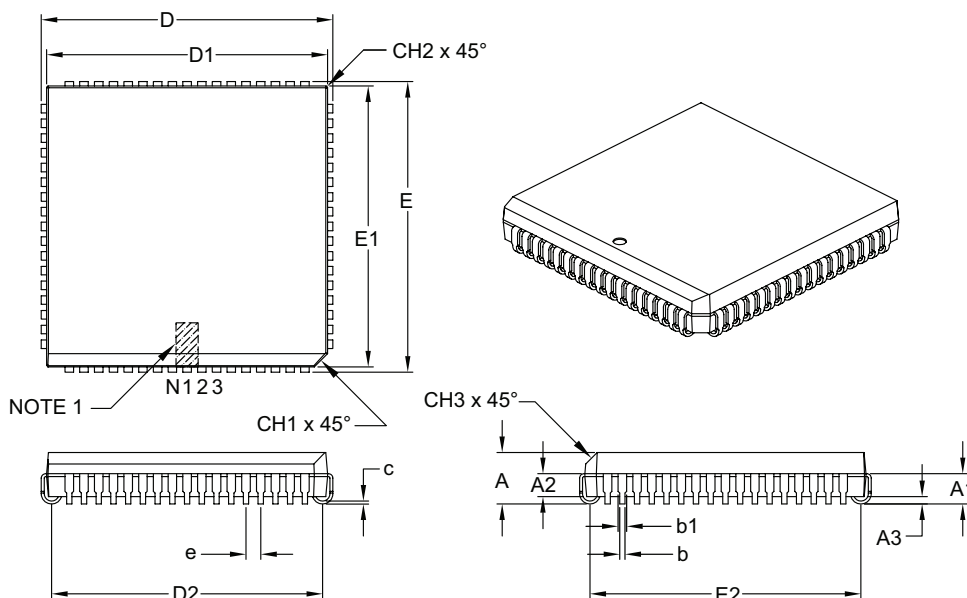

Dimension Limits	Units	INCHES		
		MIN	NOM	MAX
Number of Pins	N	68		
Pitch	e	.050		
Overall Height	A	.165	.172	.180
Contact Height	A1	.090	.105	.120
Molded Package to Contact	A2	.062	–	.083
Standoff §	A3	.020	–	–
Corner Chamfer	CH1	.042	–	.048
Chamfers	CH2	–	–	.020
Side Chamfer	CH3	.042	–	.056
Overall Width	E	.985	.990	.995
Overall Length	D	.985	.990	.995
Molded Package Width	E1	.950	.954	.958
Molded Package Length	D1	.950	.954	.958
Footprint Width	E2	.882	.910	.938
Footprint Length	D2	.882	.910	.938
Lead Thickness	c	.0075	–	.0125
Upper Lead Width	b1	.026	–	.032
Lower Lead Width	b	.013	–	.021

**Notes:**

- Pin 1 visual index feature may vary, but must be located within the hatched area.
- § Significant Characteristic.
- Dimensions D1 and E1 do not include mold flash or protrusions. Mold flash or protrusions shall not exceed .010" per side.
- Dimensioning and tolerancing per ASME Y14.5M.

---



---

## Footprint Outlines and Dimensions

---



---

### 68-Lead Plastic Leaded Chip Carrier (LS) - Square [PLCC]

**Note:** For the most current package drawings, please see the Microchip Packaging Specification located at <http://www.microchip.com/packaging>

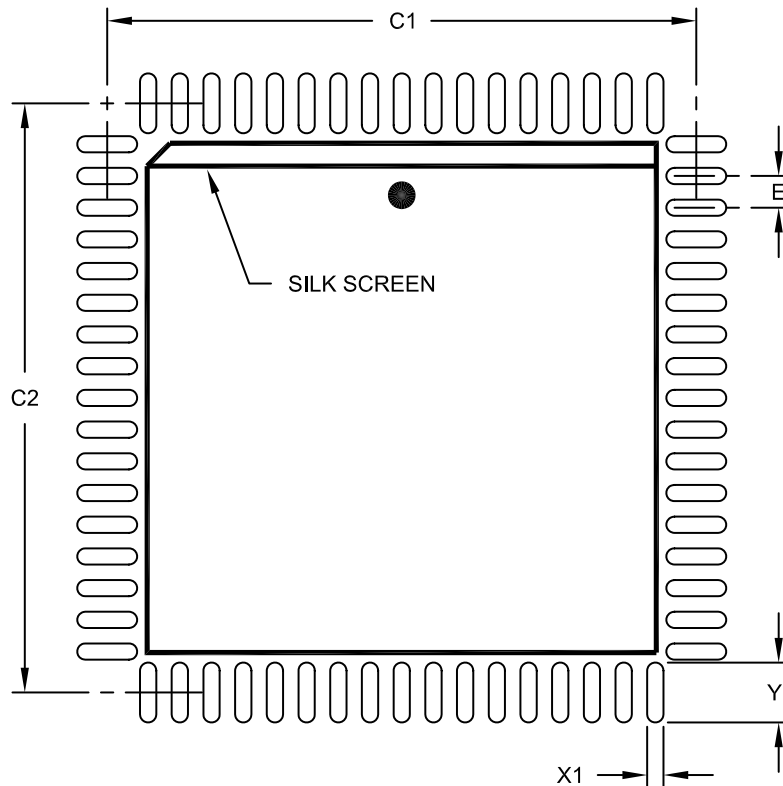

### RECOMMENDED LAND PATTERN

		Units	INCHES		
Dimension Limits			MIN	NOM	MAX
Contact Pitch	E		.050 BSC		
Contact Pad Spacing	C1			.929	
Contact Pad Spacing	C2			.929	
Contact Pad Width (X68)	X1				.026
Contact Pad Length (X68)	Y1				.094

**Notes:**

1. Dimensioning and tolerancing per ASME Y14.5M

BSC; Basic Dimension. Theoretically exact value shown without tolerances.

Microchip Technology Drawing No. C04-2049A

**Package Outlines and Dimensions**

**84-Lead Plastic Leaded Chip Carrier (L) – Square [PLCC]**

**Note:** For the most current package drawings, please see the Microchip Packaging Specification located at <http://www.microchip.com/packaging>

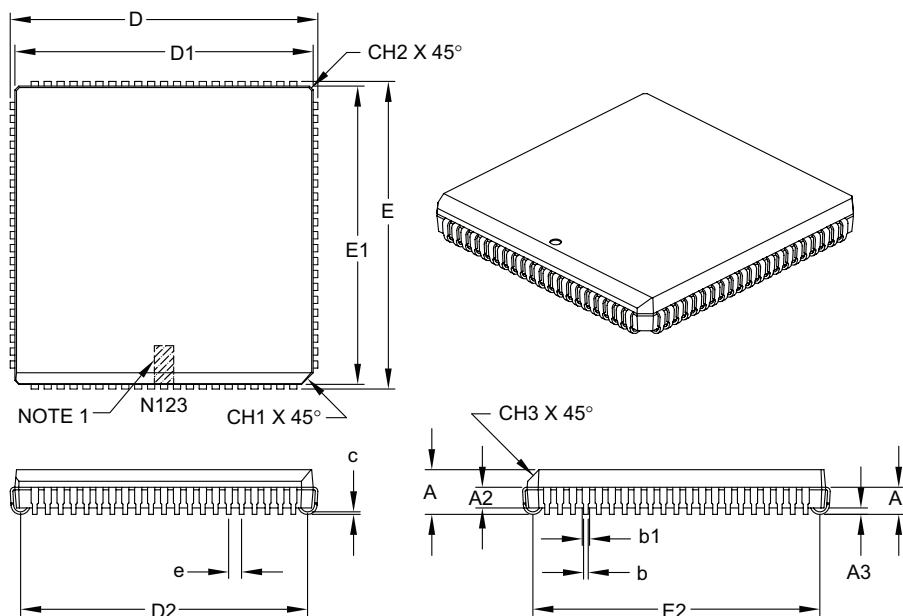

Dimension Limits	Units	INCHES		
		MIN	NOM	MAX
Number of Pins	N	84		
Pitch	e	.050		
Overall Height	A	.165	.172	.200
Contact Height	A1	.090	.105	.130
Molded Package to Contact	A2	.059	–	.080
Standoff §	A3	.020	–	–
Corner Chamfer	CH1	.042	–	.048
Chamfers	CH2	–	–	.020
Side Chamfer	CH3	.042	–	.056
Overall Width	E	1.185	1.190	1.195
Overall Length	D	1.185	1.190	1.195
Molded Package Width	E1	1.150	1.154	1.158
Molded Package Length	D1	1.150	1.154	1.158
Footprint Width	E2	1.082	1.110	1.138
Footprint Length	D2	1.082	1.110	1.138
Lead Thickness	c	.0075	–	.0125
Upper Lead Width	b1	.026	–	.032
Lower Lead Width	b	.013	–	.021

**Notes:**

- Pin 1 visual index feature may vary, but must be located within the hatched area.
- § Significant Characteristic.
- Dimensions D1 and E1 do not include mold flash or protrusions. Mold flash or protrusions shall not exceed .010" per side.
- Dimensioning and tolerancing per ASME Y14.5M.

**Footprint Outlines and Dimensions**

84-Lead Plastic Leaded Chip Carrier (L) - Square [PLCC]

**Note:** For the most current package drawings, please see the Microchip Packaging Specification located at <http://www.microchip.com/packaging>

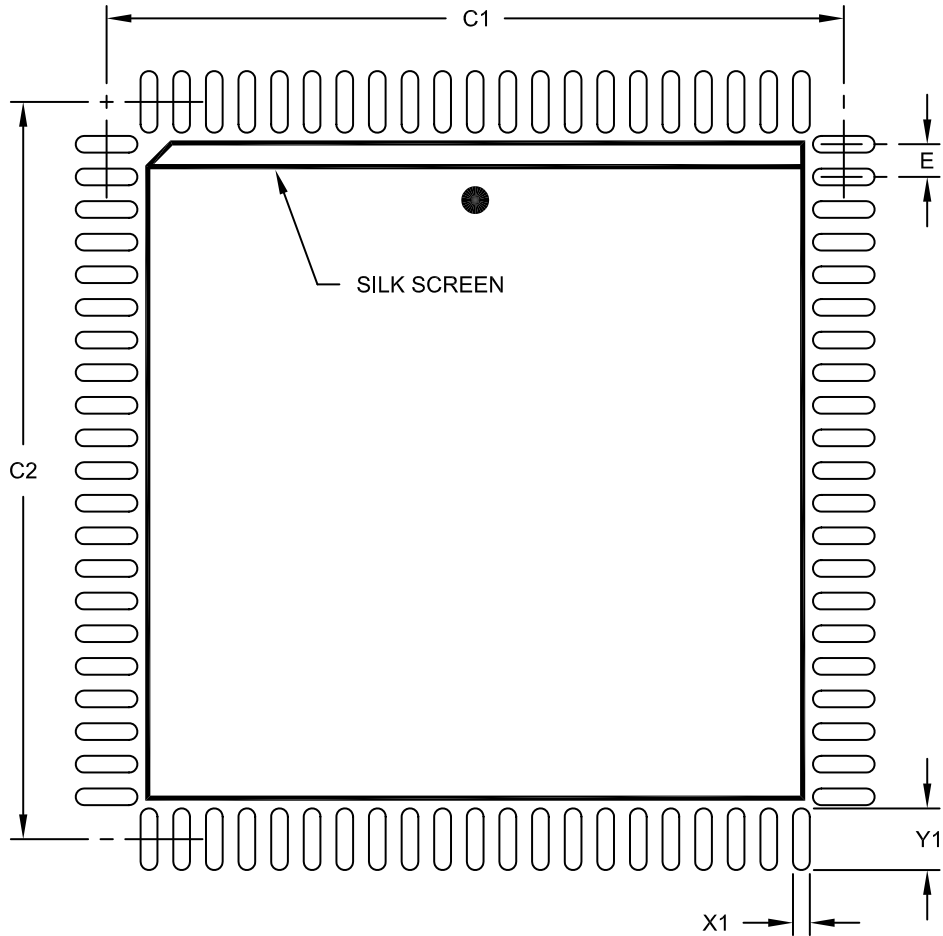

**RECOMMENDED LAND PATTERN**

		Units	INCHES		
Dimension Limits			MIN	NOM	MAX
Contact Pitch	E		.050 BSC		
Contact Pad Spacing	C1			1.130	
Contact Pad Spacing	C2			1.130	
Contact Pad Width (X84)	X1				.026
Contact Pad Length (X84)	Y1				.094

Notes:

1. Dimensioning and tolerancing per ASME Y14.5M

BSC: Basic Dimension. Theoretically exact value shown without tolerances.

Microchip Technology Drawing No. C04-2093A



**MICROCHIP**

---

---

**Package Outlines and Dimensions**

---

---

NOTES:

---

---

**Package Outlines and Dimensions**

---

---

**SOP**

**Package Outlines and Dimensions**

**8-Lead Thermally Enhanced Plastic Small Outline (SE) - Narrow, 3.90 mm Body [SOP]**

**Note:** For the most current package drawings, please see the Microchip Packaging Specification located at <http://www.microchip.com/packaging>

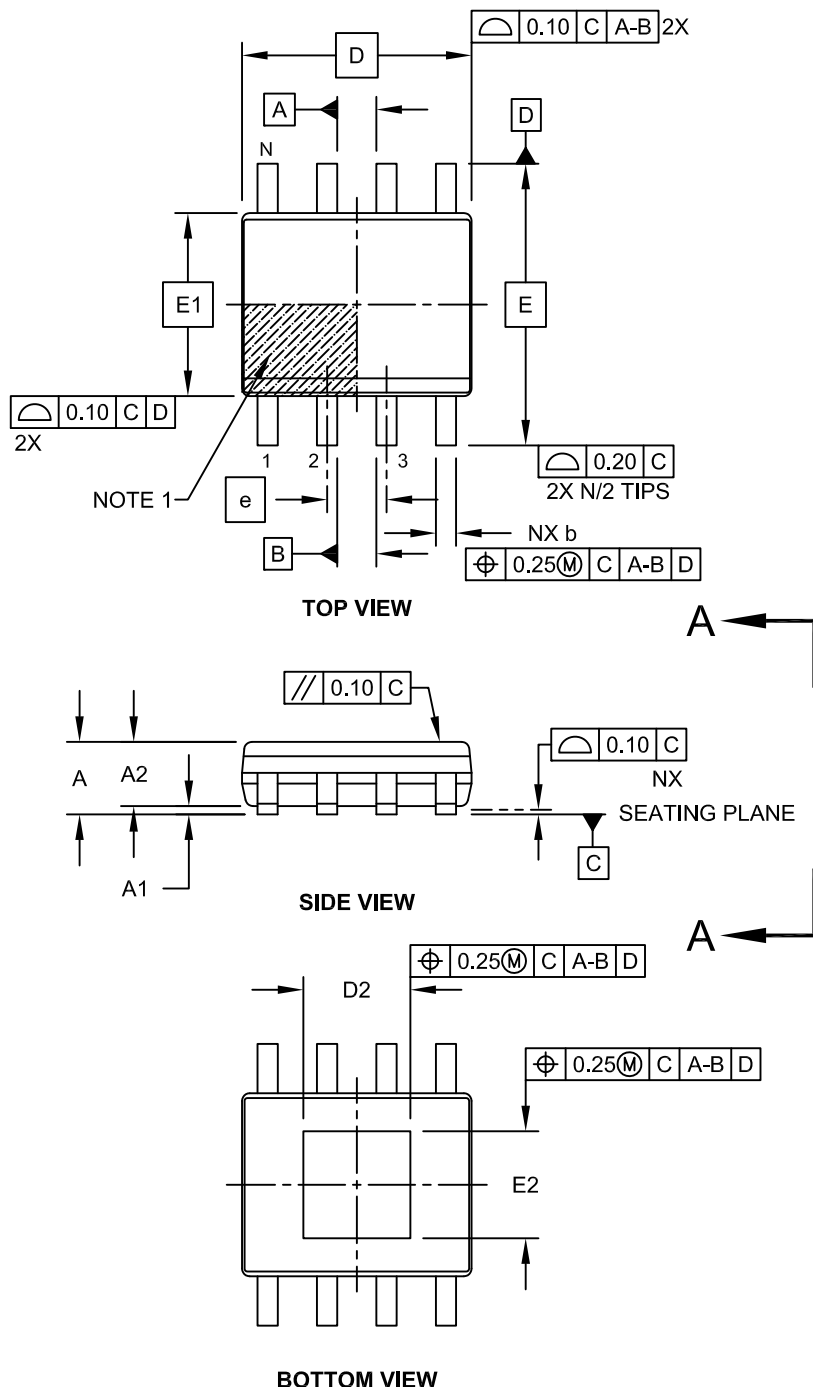



---



---

## Package Outlines and Dimensions

---



---

### 8-Lead Thermally Enhanced Plastic Small Outline (SE) - Narrow, 3.90 mm Body [SOP]

**Note:** For the most current package drawings, please see the Microchip Packaging Specification located at <http://www.microchip.com/packaging>

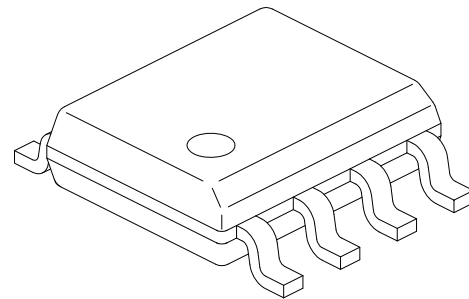
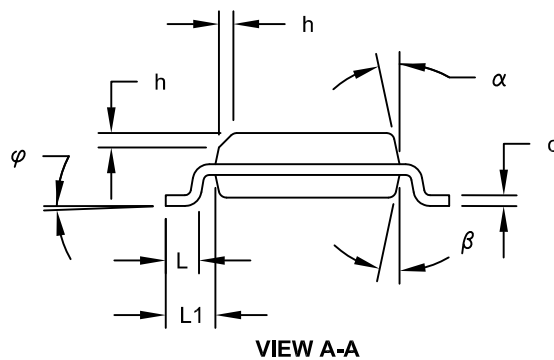

		MILLIMETERS		
Units				
Dimension Limits		MIN	NOM	MAX
Number of Pins	N	8		
Pitch	e	1.27		
Overall Height	A	-	-	1.75
Molded Package Thickness	A2	1.25	-	-
Standoff §	A1	0.00	-	0.15
Overall Width	E	5.80	6.00	6.20
Molded Package Width	E1	3.80	3.90	4.00
Overall Length	D	4.70	4.90	5.10
Exposed Pad Width	E2	2.19	2.29	2.39
Exposed Pad Length	D2	2.19	2.29	2.39
Chamfer (Optional)	h	0.25	-	0.50
Foot Length	L	0.40	-	1.27
Footprint	L1	1.04	1.04	1.04
Foot Angle	φ	0°	-	8°
Lead Thickness	c	0.17	-	0.25
Lead Width	b	0.31	-	0.51
Mold Draft Angle Top	α	5°	-	15°
Mold Draft Angle Bottom	β	5°	-	15°

**Notes:**

1. Pin 1 visual index feature may vary, but must be located within the hatched area.
2. § Significant Characteristic
3. Dimensions D and E1 do not include mold flash or protrusions. Mold flash or protrusions shall not exceed 0.15mm per side.
4. Dimensioning and tolerancing per ASME Y14.5M

BSC: Basic Dimension. Theoretically exact value shown without tolerances.

REF: Reference Dimension, usually without tolerance, for information purposes only.

**Footprint Outlines and Dimensions**

**8-Lead Thermally Enhanced Plastic Small Outline (SE) - Narrow, 3.90 mm Body [SOP]**

**Note:** For the most current package drawings, please see the Microchip Packaging Specification located at <http://www.microchip.com/packaging>

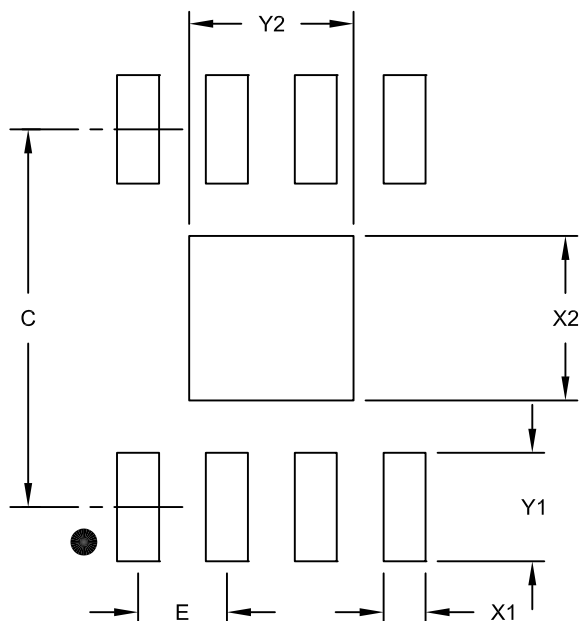

**RECOMMENDED LAND PATTERN**

		Units	MILLIMETERS		
Dimension Limits			MIN	NOM	MAX
Contact Pitch	E		1.27 BSC		
Contact Pad Spacing	C			5.40	
Contact Pad Width (X8)	X1				0.60
Contact Pad Length (X8)	Y1				1.55
Exposed Pad Width	X2				2.35
Exposed Pad Length	Y2				2.35

**Notes:**

1. Dimensioning and tolerancing per ASME Y14.5M

BSC: Basic Dimension. Theoretically exact value shown without tolerances.

Microchip Technology Drawing No. C04-2121A

---

---

**Package Outlines and Dimensions**

---

---

**SOIC**

**Package Outlines and Dimensions**

**8-Lead Small Outline Integrated Circuit (7HX) - .150 In. (3.90 mm) Body [SOIC]  
With 1.65x1.65 mm Exposed Pad**

**Note:** For the most current package drawings, please see the Microchip Packaging Specification located at <http://www.microchip.com/packaging>

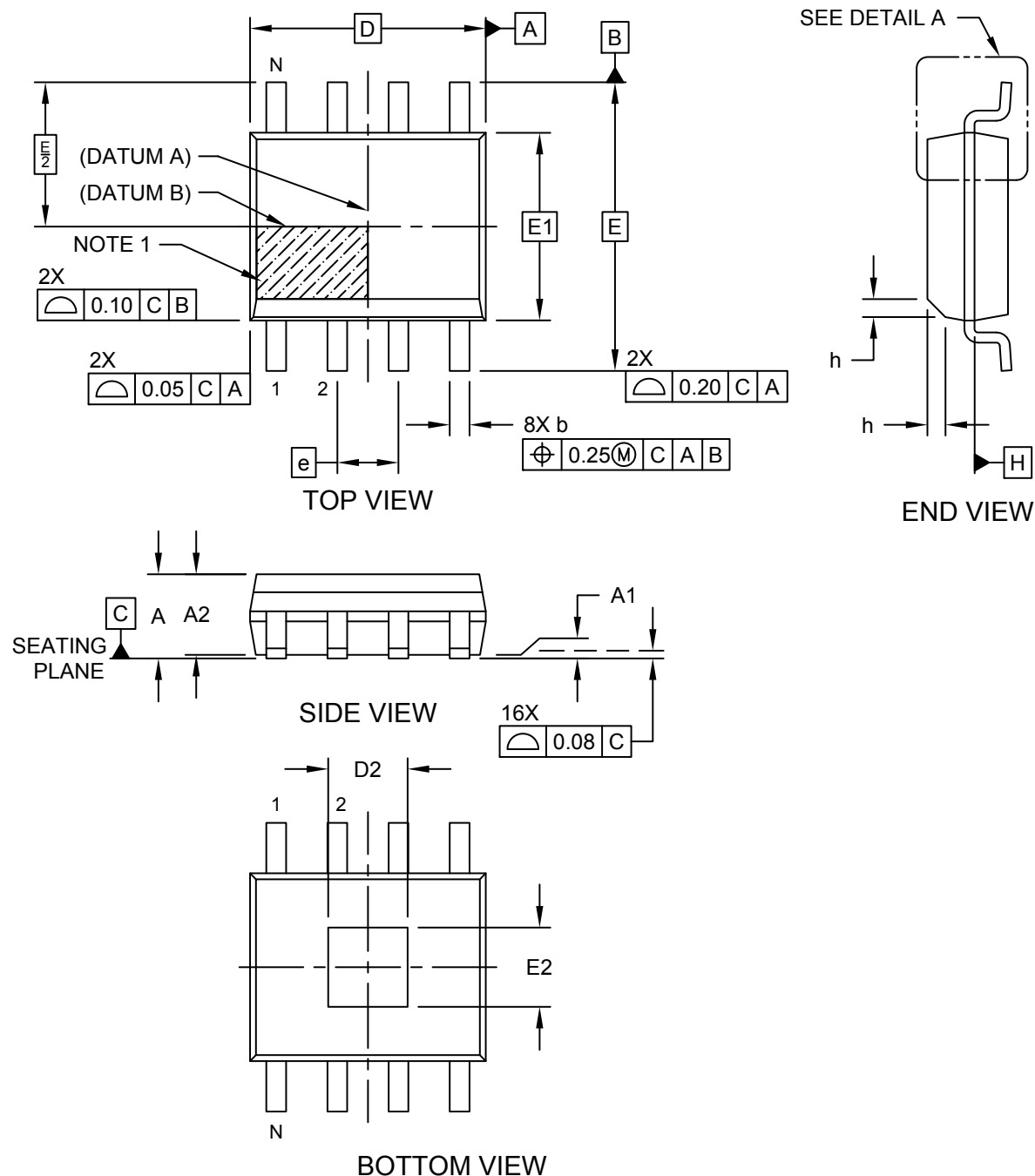

---



---

## Package Outlines and Dimensions

---



---

### 8-Lead Small Outline Integrated Circuit (7HX) - .150 In. (3.90 mm) Body [SOIC] With 1.65x1.65 mm Exposed Pad

**Note:** For the most current package drawings, please see the Microchip Packaging Specification located at <http://www.microchip.com/packaging>

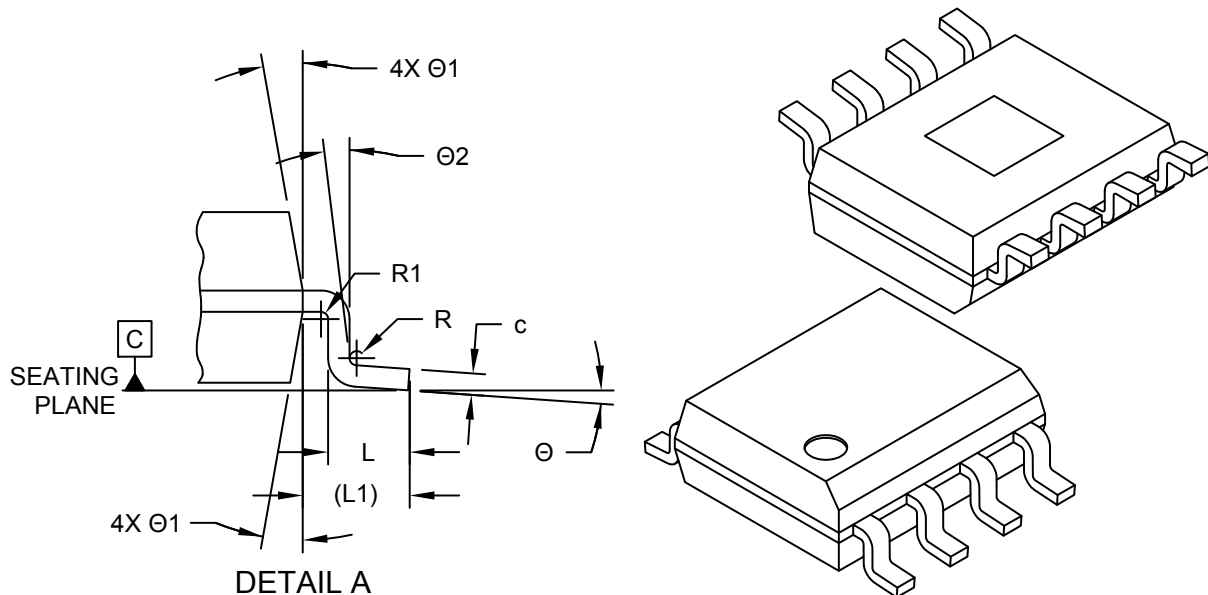

Dimension Limits	Units	MILLIMETERS		
		MIN	NOM	MAX
Number of Pins	N	8		
Pitch	e	1.27 BSC		
Overall Height	A	-	-	1.70
Molded Package Thickness	A2	1.25	1.45	-
Standoff §	A1	0.00	-	0.15
Overall Width	E	6.00 BSC		
Molded Package Width	E1	3.90 BSC		
Overall Length	D	4.85 BSC		
Exposed Pad Width	E2	1.65	-	-
Exposed Pad Length	D2	1.65	-	-
Chamfer (Optional)	h	0.38	-	-
Foot Length	L	0.40	0.71	1.27
Footprint	L1	1.04 REF		
Lead Thickness	c	0.10	-	0.25
Lead Width	b	0.31	-	0.51
Foot Angle	Ø	0°	-	8°
Lead Angle	Ø2	0°	-	-
Mold Draft Angle	Ø1	0°	-	15°

**Notes:**

1. Pin 1 visual index feature may vary, but must be located within the hatched area.
2. Dimensioning and tolerancing per ASME Y14.5M
  - BSC: Basic Dimension. Theoretically exact value shown without tolerances.
  - REF: Reference Dimension, usually without tolerance, for information purposes only.

**Footprint Outlines and Dimensions**

**8-Lead Small Outline Integrated Circuit (7HX) - .150 In. (3.90 mm) Body [SOIC]  
With 1.65x1.65 mm Exposed Pad**

**Note:** For the most current package drawings, please see the Microchip Packaging Specification located at <http://www.microchip.com/packaging>

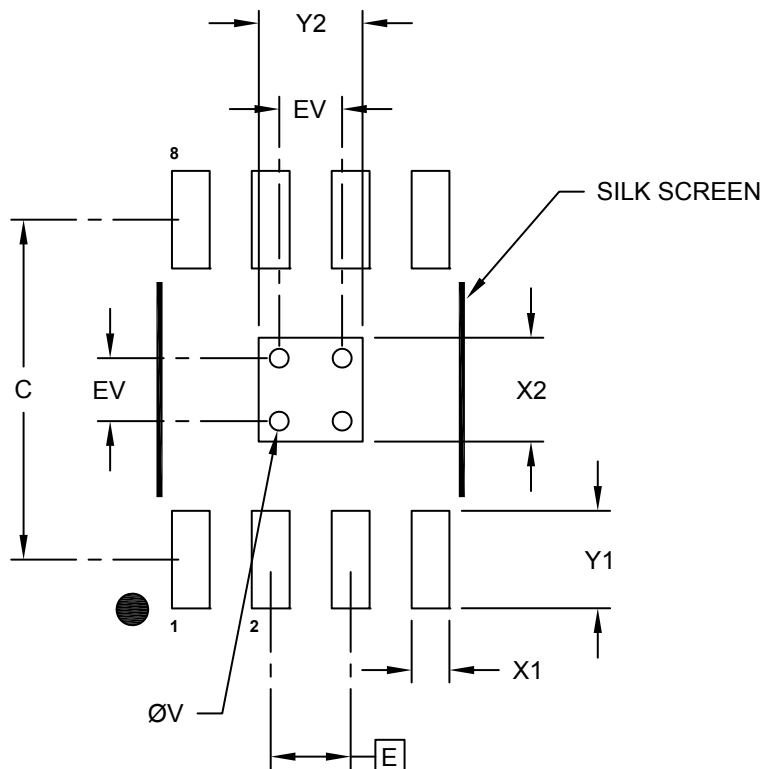

**RECOMMENDED LAND PATTERN**

Dimension Limits	Units	MILLIMETERS		
		MIN	NOM	MAX
Contact Pitch	E	1.27 BSC		
Optional Center Pad Width	X2	1.65		
Optional Center Pad Length	Y2	2.65		
Contact Pad Spacing	C		5.40	
Contact Pad Width (X20)	X1			0.60
Contact Pad Length (X20)	Y1			1.55
Thermal Via Diameter	V		0.30	
Thermal Via Pitch	EV		1.00	

**Notes:**

1. Dimensioning and tolerancing per ASME Y14.5M  
BSC: Basic Dimension. Theoretically exact value shown without tolerances.
2. For best soldering results, thermal vias, if used, should be filled or tented to avoid solder loss during reflow process

**Package Outlines and Dimensions**

**8-Lead Small Outline Integrated Circuit (5DX) - .150 In. (3.90 mm) Body [SOIC]  
With 3.30x2.41 mm Exposed Pad**

**Note:** For the most current package drawings, please see the Microchip Packaging Specification located at <http://www.microchip.com/packaging>

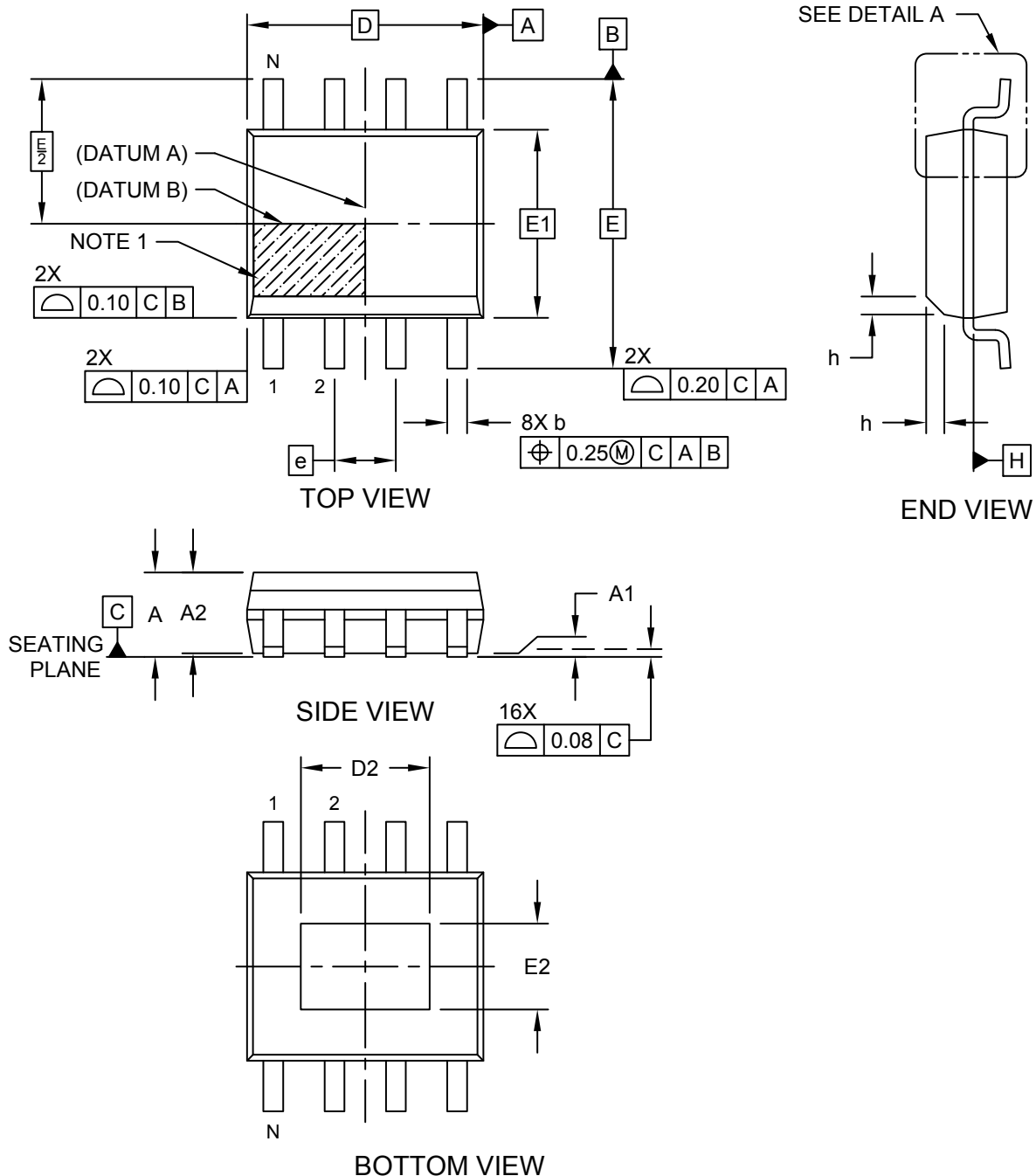

**Package Outlines and Dimensions**

**8-Lead Small Outline Integrated Circuit (5DX) - .150 In. (3.90 mm) Body [SOIC]  
With 3.30x2.41 mm Exposed Pad**

**Note:** For the most current package drawings, please see the Microchip Packaging Specification located at <http://www.microchip.com/packaging>

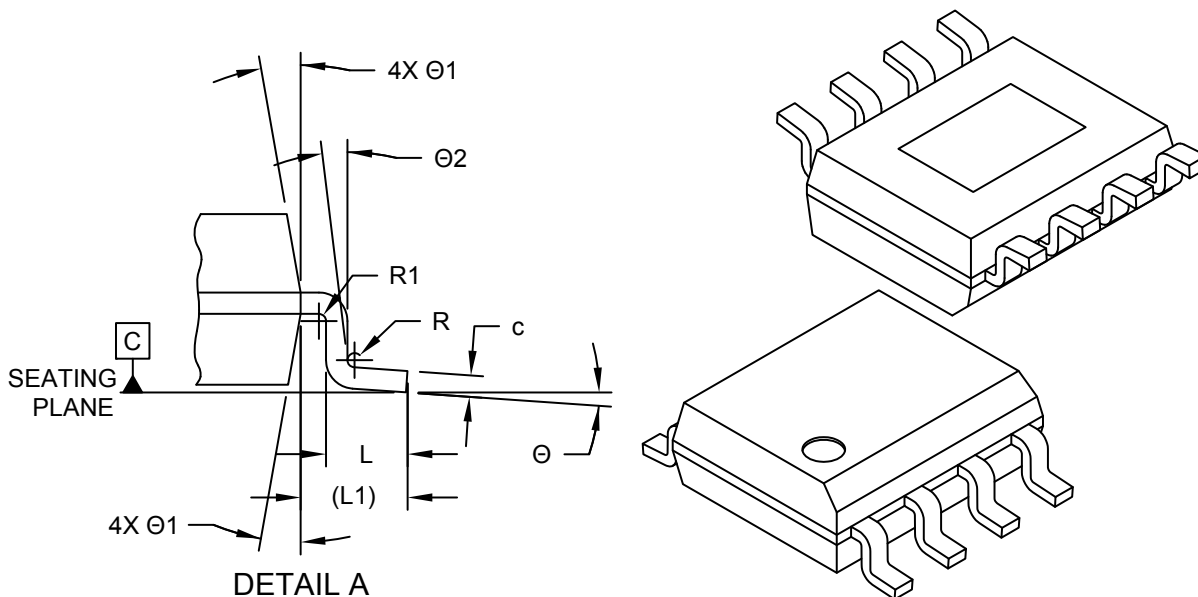

Dimension Limits	Units	MILLIMETERS		
		MIN	NOM	MAX
Number of Pins	N	8		
Pitch	e	1.27 BSC		
Overall Height	A	-	-	1.70
Molded Package Thickness	A2	1.25	1.45	-
Standoff §	A1	0.00	-	0.15
Overall Width	E	6.00 BSC		
Molded Package Width	E1	3.90 BSC		
Overall Length	D	4.90 BSC		
Exposed Pad Width	E2	1.78	-	-
Exposed Pad Length	D2	2.67	-	-
Chamfer (Optional)	h	0.15	-	-
Foot Length	L	0.40	0.71	1.27
Footprint	L1	1.04 REF		
Lead Thickness	c	0.10	-	0.25
Lead Width	b	0.31	-	0.51
Foot Angle	Ø	0°	-	8°
Lead Angle	Ø2	0°	-	-
Mold Draft Angle	Ø1	0°	-	15°

**Notes:**

- Pin 1 visual index feature may vary, but must be located within the hatched area.
- Dimensioning and tolerancing per ASME Y14.5M  
 BSC: Basic Dimension. Theoretically exact value shown without tolerances.  
 REF: Reference Dimension, usually without tolerance, for information purposes only.



---



---

## Footprint Outlines and Dimensions

---



---

### 8-Lead Small Outline Integrated Circuit (5DX) - .150 In. (3.90 mm) Body [SOIC] With 3.30x2.41 mm Exposed Pad

**Note:** For the most current package drawings, please see the Microchip Packaging Specification located at <http://www.microchip.com/packaging>

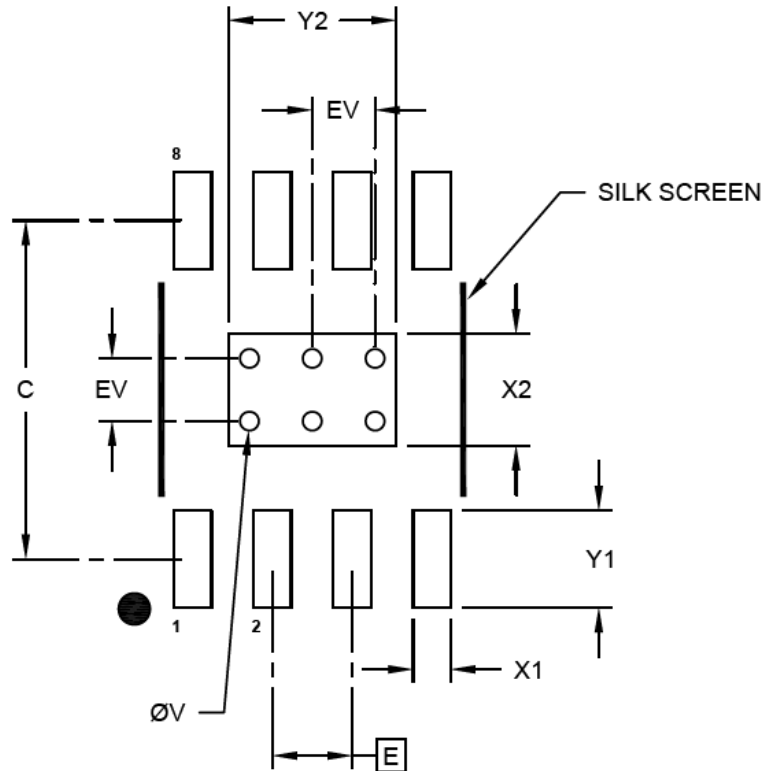

### RECOMMENDED LAND PATTERN

Dimension Limits	Units	MILLIMETERS		
		MIN	NOM	MAX
Contact Pitch	E	1.27 BSC		
Optional Center Pad Width	X2	1.78		
Optional Center Pad Length	Y2	2.67		
Contact Pad Spacing	C		5.40	
Contact Pad Width (X20)	X1			0.60
Contact Pad Length (X20)	Y1			1.55
Thermal Via Diameter	V		0.30	
Thermal Via Pitch	EV		1.00	

**Notes:**

1. Dimensioning and tolerancing per ASME Y14.5M  
BSC: Basic Dimension. Theoretically exact value shown without tolerances.
2. For best soldering results, thermal vias, if used, should be filled or tented to avoid solder loss during reflow process

**Package Outlines and Dimensions**

**8-Lead Plastic Small Outline (SN) - Narrow, 3.90 mm Body [SOIC]**

**Note:** For the most current package drawings, please see the Microchip Packaging Specification located at <http://www.microchip.com/packaging>

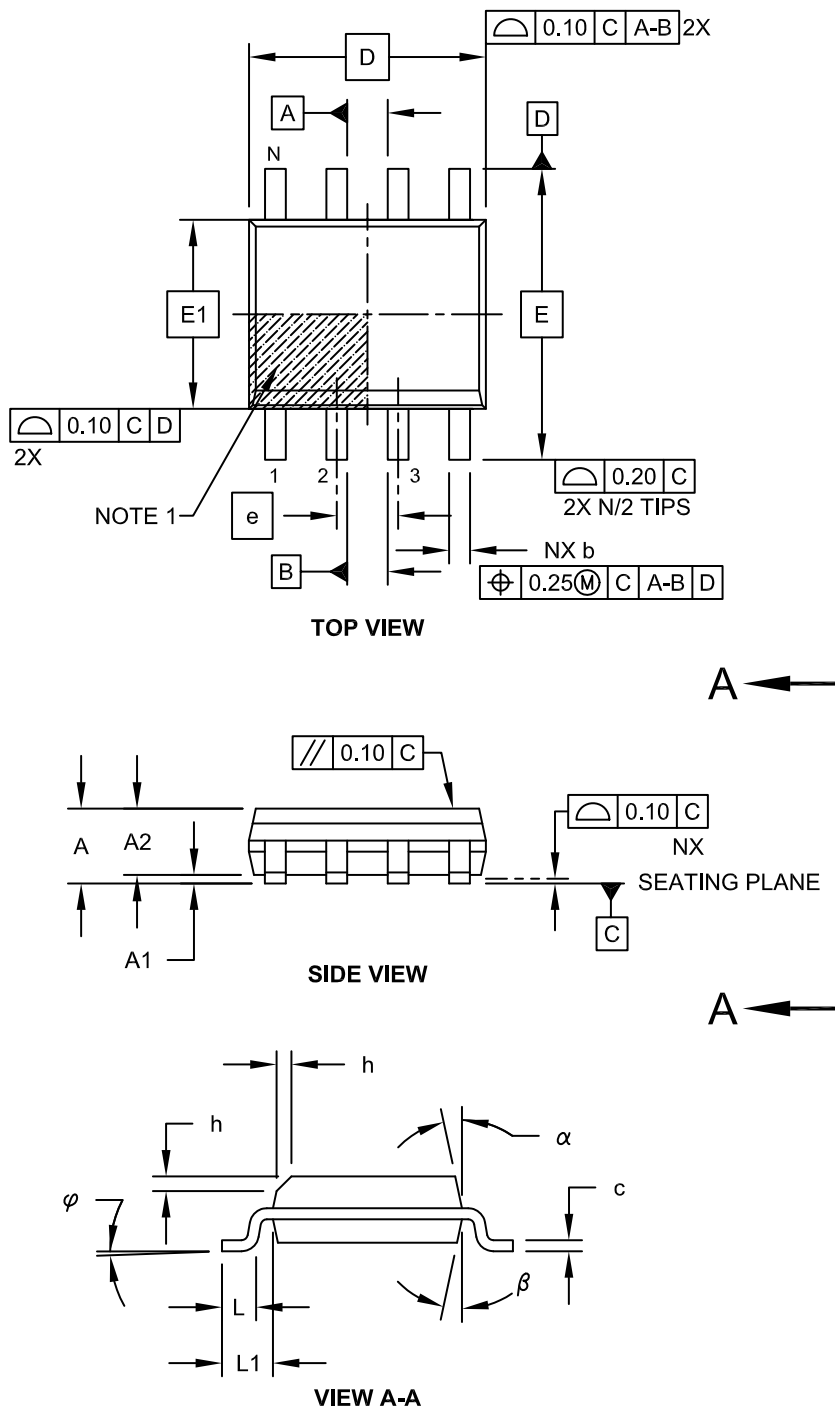

---



---

## Package Outlines and Dimensions

---



---

### 8-Lead Plastic Small Outline (SN) - Narrow, 3.90 mm Body [SOIC]

**Note:** For the most current package drawings, please see the Microchip Packaging Specification located at <http://www.microchip.com/packaging>

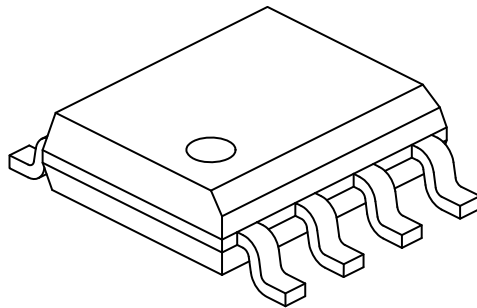

		Units	MILLIMETERS		
Dimension Limits			MIN	NOM	MAX
Number of Pins	N		8		
Pitch	e		1.27 BSC		
Overall Height	A	-	-	1.75	
Molded Package Thickness	A2	1.25	-		
Standoff §	A1	0.10	-		
Overall Width	E		6.00 BSC		
Molded Package Width	E1		3.90 BSC		
Overall Length	D		4.90 BSC		
Chamfer (Optional)	h	0.25	-	0.50	
Foot Length	L	0.40	-		
Footprint	L1		1.04 REF		
Foot Angle	$\varphi$	0°	-	8°	
Lead Thickness	c	0.17	-		
Lead Width	b	0.31	-		
Mold Draft Angle Top	$\alpha$	5°	-		
Mold Draft Angle Bottom	$\beta$	5°	-		

**Notes:**

1. Pin 1 visual index feature may vary, but must be located within the hatched area.
2. § Significant Characteristic
3. Dimensions D and E1 do not include mold flash or protrusions. Mold flash or protrusions shall not exceed 0.15mm per side.
4. Dimensioning and tolerancing per ASME Y14.5M

BSC: Basic Dimension. Theoretically exact value shown without tolerances.

REF: Reference Dimension, usually without tolerance, for information purposes only.

**Footprint Outlines and Dimensions**

**8-Lead Plastic Small Outline (SN) – Narrow, 3.90 mm Body [SOIC]**

**Note:** For the most current package drawings, please see the Microchip Packaging Specification located at <http://www.microchip.com/packaging>

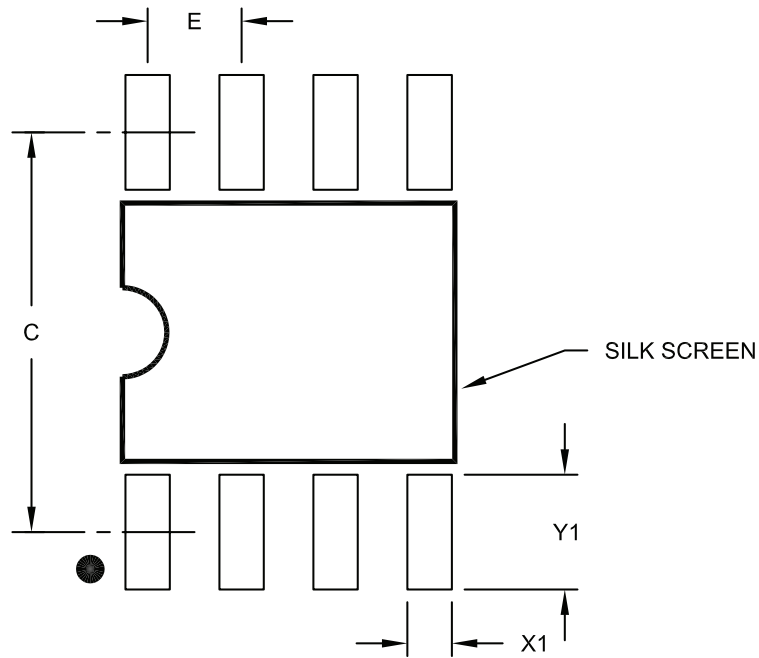

**RECOMMENDED LAND PATTERN**

Dimension Limits	Units	MILLIMETERS		
		MIN	NOM	MAX
Contact Pitch	E	1.27 BSC		
Contact Pad Spacing	C		5.40	
Contact Pad Width (X8)	X1			0.60
Contact Pad Length (X8)	Y1			1.55

**Notes:**

1. Dimensioning and tolerancing per ASME Y14.5M

BSC: Basic Dimension. Theoretically exact value shown without tolerances.

Microchip Technology Drawing No. C04-2057A

**Package Outlines and Dimensions**

**8-Lead Plastic Small Outline (OA) - Narrow, 3.90 mm Body [SOIC]**

**Note:** For the most current package drawings, please see the Microchip Packaging Specification located at <http://www.microchip.com/packaging>

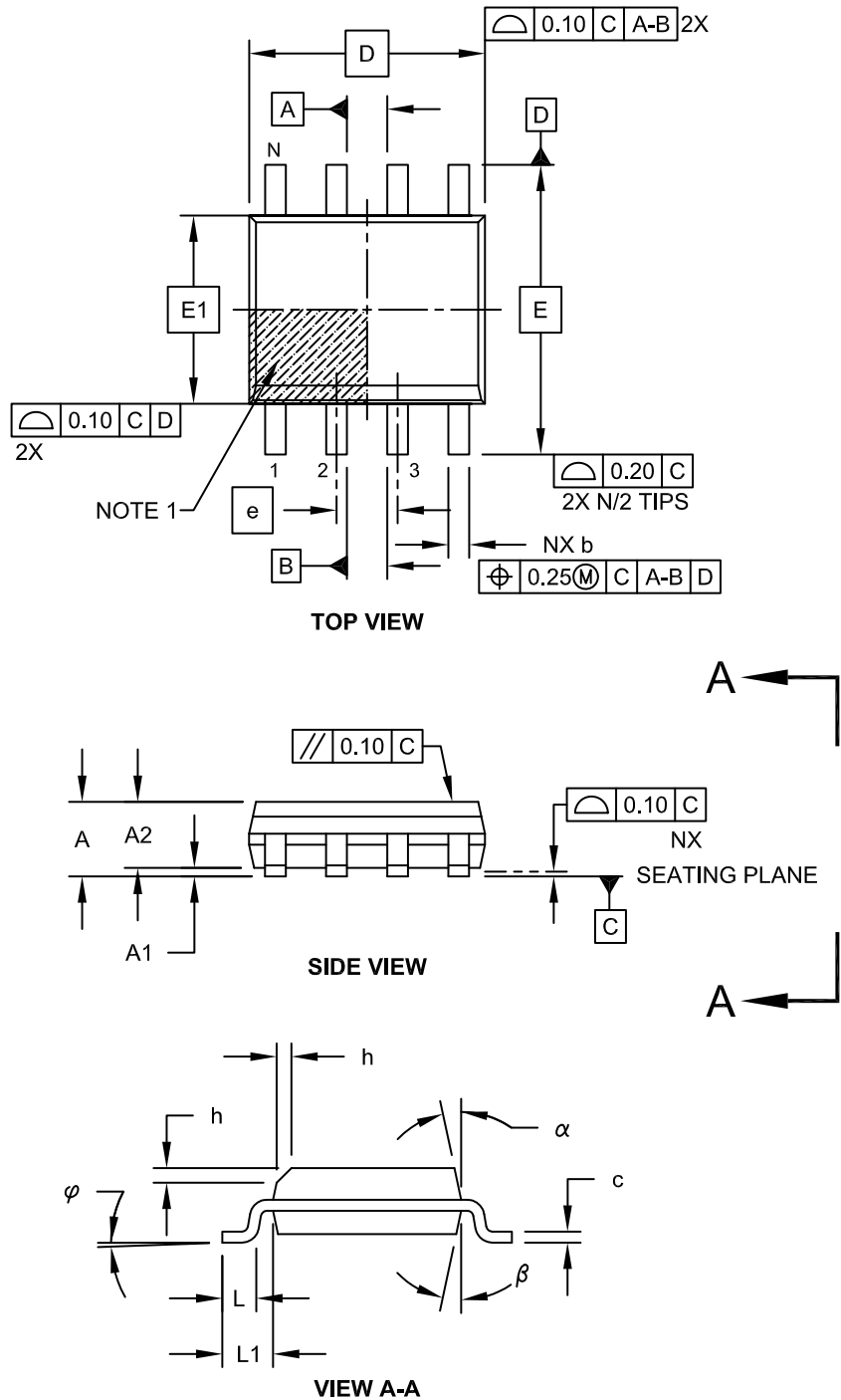

**Package Outlines and Dimensions**

**8-Lead Plastic Small Outline (OA) - Narrow, 3.90 mm Body [SOIC]**

**Note:** For the most current package drawings, please see the Microchip Packaging Specification located at <http://www.microchip.com/packaging>

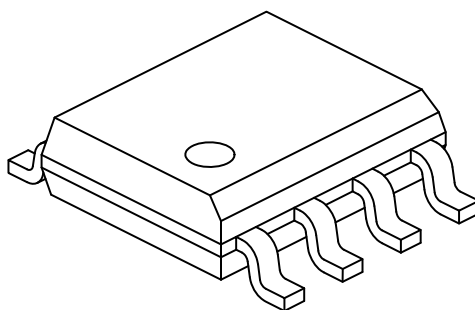

Dimension Limits	Units	MILLIMETERS		
		MIN	NOM	MAX
Number of Pins	N	8		
Pitch	e	1.27 BSC		
Overall Height	A	-	-	1.75
Molded Package Thickness	A2	1.25	-	-
Standoff §	A1	0.10	-	0.25
Overall Width	E	6.00 BSC		
Molded Package Width	E1	3.90 BSC		
Overall Length	D	4.90 BSC		
Chamfer (Optional)	h	0.25	-	0.50
Foot Length	L	0.40	-	1.27
Footprint	L1	1.04 REF		
Foot Angle	φ	0°	-	8°
Lead Thickness	c	0.17	-	0.25
Lead Width	b	0.31	-	0.51
Mold Draft Angle Top	α	5°	-	15°
Mold Draft Angle Bottom	β	5°	-	15°

**Notes:**

1. Pin 1 visual index feature may vary, but must be located within the hatched area.
2. § Significant Characteristic
3. Dimensions D and E1 do not include mold flash or protrusions. Mold flash or protrusions shall not exceed 0.15mm per side.
4. Dimensioning and tolerancing per ASME Y14.5M

BSC: Basic Dimension. Theoretically exact value shown without tolerances.

REF: Reference Dimension, usually without tolerance, for information purposes only.

---



---

## Footprint Outlines and Dimensions

---



---

### 8-Lead Plastic Small Outline (OA) – Narrow, 3.90 mm Body [SOIC]

**Note:** For the most current package drawings, please see the Microchip Packaging Specification located at <http://www.microchip.com/packaging>

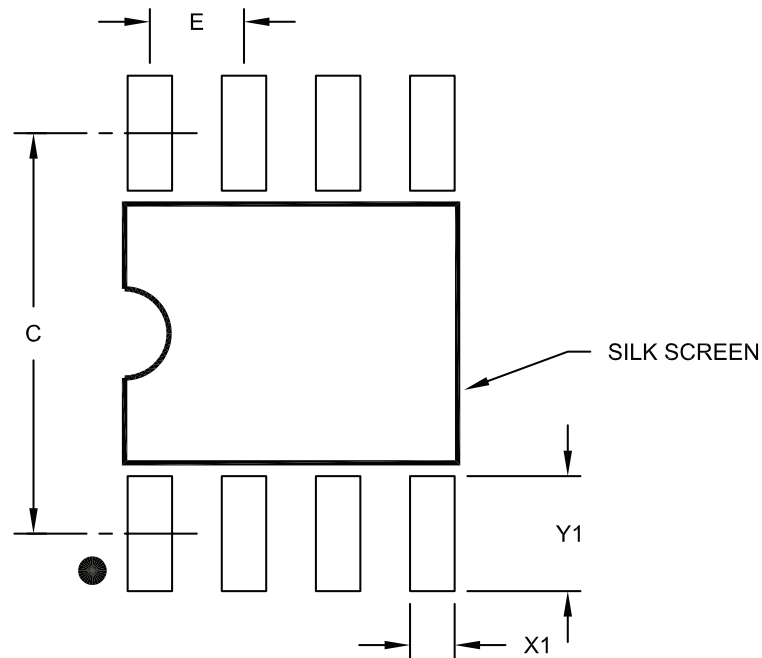

RECOMMENDED LAND PATTERN

Dimension Limits	Units	MILLIMETERS		
		MIN	NOM	MAX
Contact Pitch	E	1.27 BSC		
Contact Pad Spacing	C		5.40	
Contact Pad Width (X8)	X1			0.60
Contact Pad Length (X8)	Y1			1.55

**Notes:**

1. Dimensioning and tolerancing per ASME Y14.5M

BSC: Basic Dimension. Theoretically exact value shown without tolerances.

Microchip Technology Drawing No. C04-2057A

## Package Outlines and Dimensions

### 8-Lead Thermally Enhanced Plastic Small Outline (SE) - Narrow, 3.90 mm Body [SOIC]

**Note:** For the most current package drawings, please see the Microchip Packaging Specification located at <http://www.microchip.com/packaging>

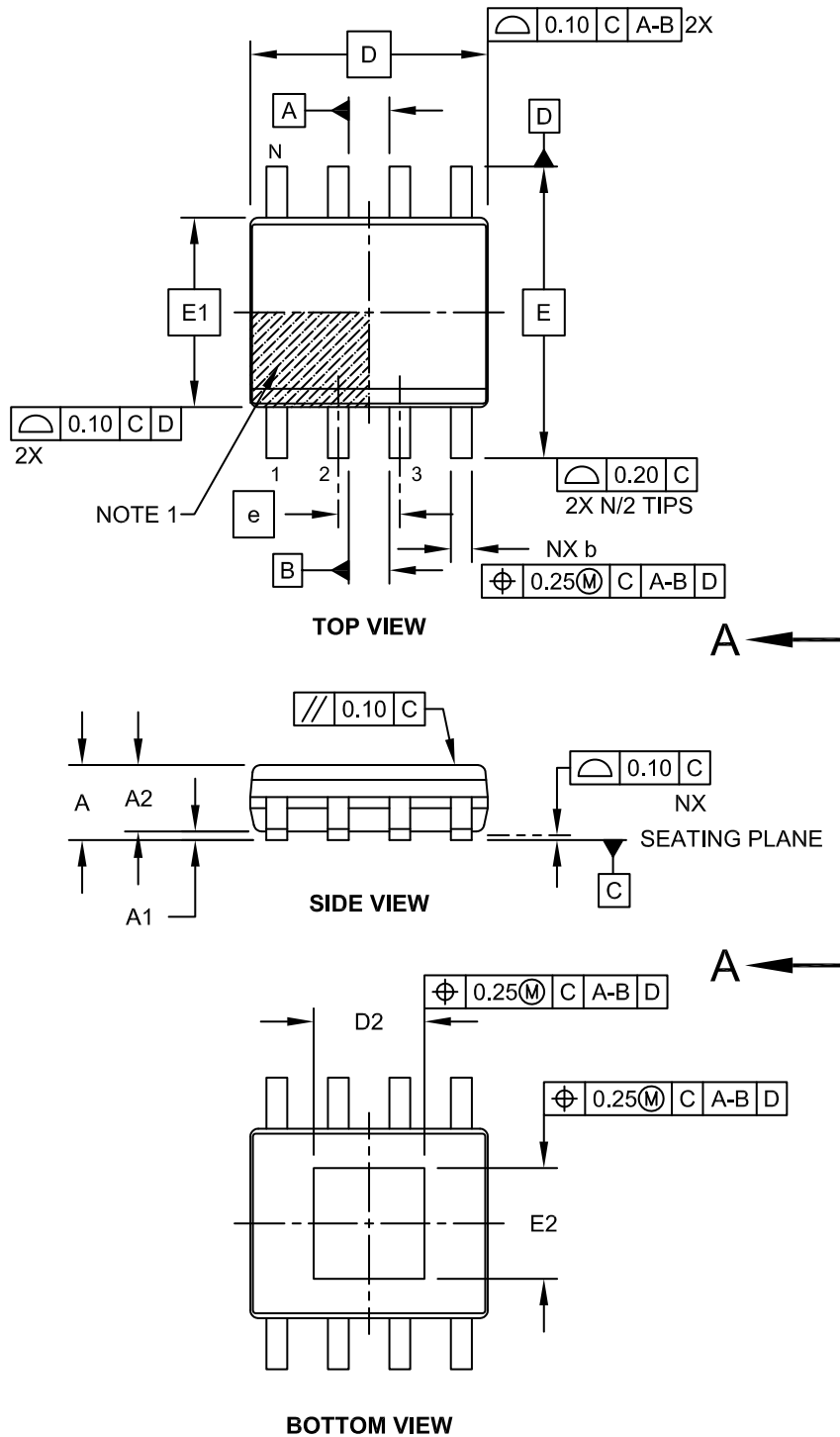



---



---

## Package Outlines and Dimensions

---



---

### 8-Lead Thermally Enhanced Plastic Small Outline (SE) - Narrow, 3.90 mm Body [SOIC]

**Note:** For the most current package drawings, please see the Microchip Packaging Specification located at <http://www.microchip.com/packaging>

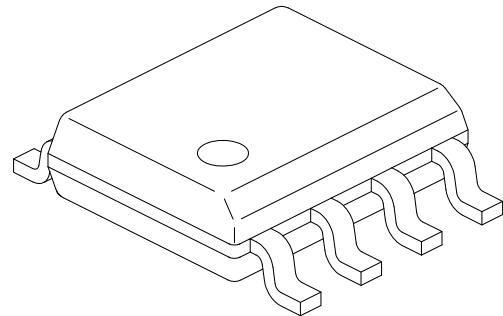
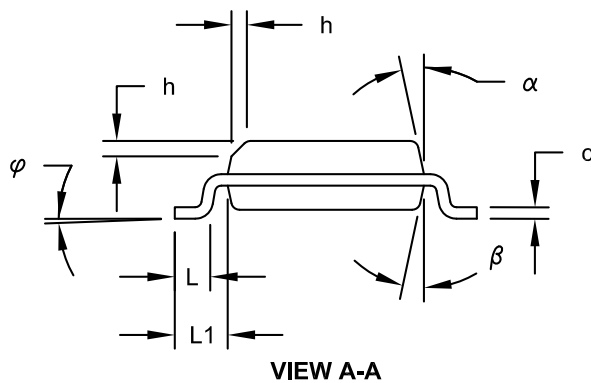

Dimension Limits	Units	MILLIMETERS		
		MIN	NOM	MAX
Number of Pins	N	8		
Pitch	e	1.27 BSC		
Overall Height	A	-	-	1.75
Molded Package Thickness	A2	1.25	-	-
Standoff §	A1	0.10	-	0.15
Overall Width	E	6.00 BSC		
Molded Package Width	E1	3.90 BSC		
Overall Length	D	4.90 BSC		
Exposed Pad Width	E2	2.19	2.29	2.39
Exposed Pad Length	D2	2.19	2.29	2.39
Chamfer (Optional)	h	0.25	-	0.50
Foot Length	L	0.40	-	1.27
Footprint	L1	1.04 REF		
Foot Angle	$\varphi$	0°	-	8°
Lead Thickness	c	0.17	-	0.25
Lead Width	b	0.31	-	0.51
Mold Draft Angle Top	$\alpha$	5°	-	15°
Mold Draft Angle Bottom	$\beta$	5°	-	15°

**Notes:**

1. Pin 1 visual index feature may vary, but must be located within the hatched area.
2. § Significant Characteristic
3. Dimensions D and E1 do not include mold flash or protrusions. Mold flash or protrusions shall not exceed 0.15mm per side.
4. Dimensioning and tolerancing per ASME Y14.5M

BSC: Basic Dimension. Theoretically exact value shown without tolerances.

REF: Reference Dimension, usually without tolerance, for information purposes only.

**Footprint Outlines and Dimensions**

**8-Lead Thermally Enhanced Plastic Small Outline (SE) - Narrow, 3.90 mm Body [SOIC]**

**Note:** For the most current package drawings, please see the Microchip Packaging Specification located at <http://www.microchip.com/packaging>

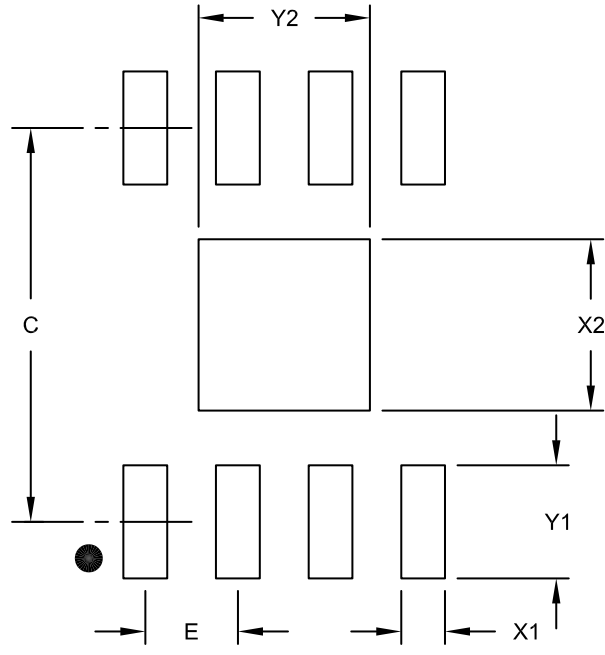

**RECOMMENDED LAND PATTERN**

Dimension Limits	Units	MILLIMETERS		
		MIN	NOM	MAX
Contact Pitch	E	1.27 BSC		
Contact Pad Spacing	C		5.40	
Contact Pad Width (X8)	X1			0.60
Contact Pad Length (X8)	Y1			1.55
Exposed Pad Width	X2			2.35
Exposed Pad Length	Y2			2.35

**Notes:**

1. Dimensioning and tolerancing per ASME Y14.5M  
 BSC: Basic Dimension. Theoretically exact value shown without tolerances.

**Package Outlines and Dimensions**

**14-Lead Plastic Small Outline (SL) - Narrow, 3.90 mm Body [SOIC]**

**Note:** For the most current package drawings, please see the Microchip Packaging Specification located at <http://www.microchip.com/packaging>

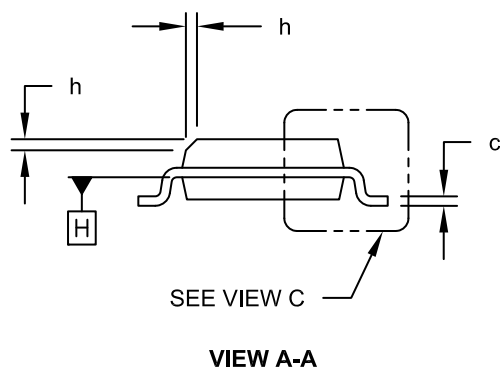
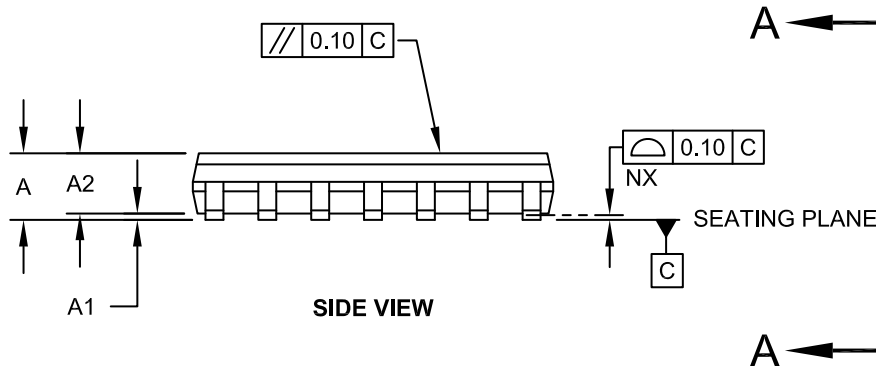
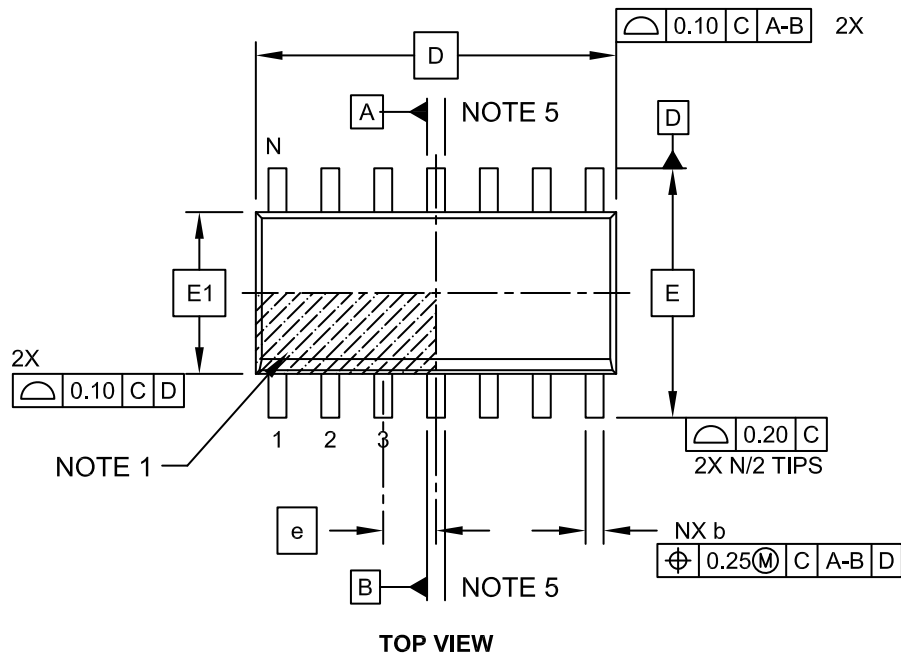

**Package Outlines and Dimensions**

**14-Lead Plastic Small Outline (SL) - Narrow, 3.90 mm Body [SOIC]**

**Note:** For the most current package drawings, please see the Microchip Packaging Specification located at <http://www.microchip.com/packaging>

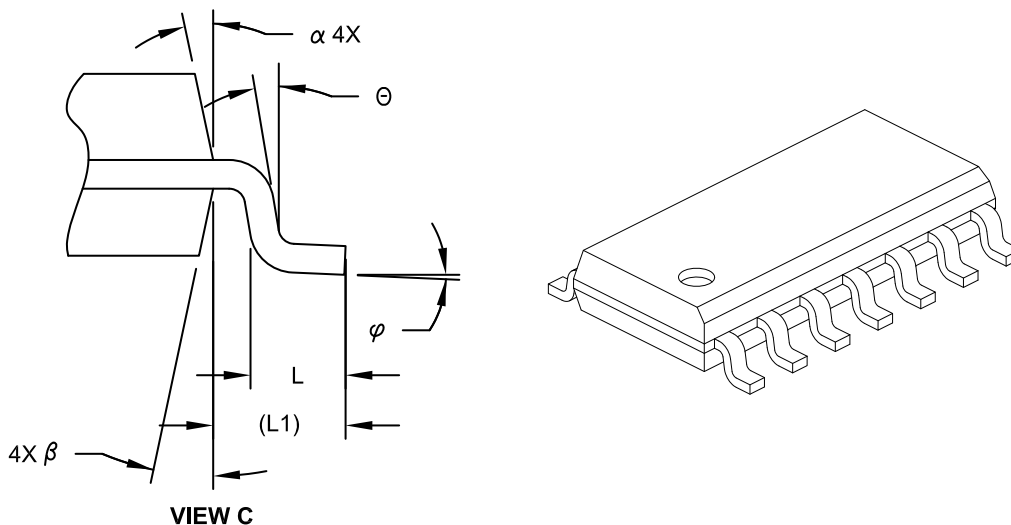

		Units	MILLIMETERS		
Dimension Limits			MIN	NOM	MAX
Number of Pins	N		14		
Pitch	e		1.27 BSC		
Overall Height	A	-	-	-	1.75
Molded Package Thickness	A2	1.25	-	-	-
Standoff §	A1	0.10	-	-	0.25
Overall Width	E		6.00 BSC		
Molded Package Width	E1		3.90 BSC		
Overall Length	D		8.65 BSC		
Chamfer (Optional)	h	0.25	-	-	0.50
Foot Length	L	0.40	-	-	1.27
Footprint	L1		1.04 REF		
Lead Angle	θ	0°	-	-	-
Foot Angle	φ	0°	-	-	8°
Lead Thickness	c	0.10	-	-	0.25
Lead Width	b	0.31	-	-	0.51
Mold Draft Angle Top	α	5°	-	-	15°
Mold Draft Angle Bottom	β	5°	-	-	15°

**Notes:**

- Pin 1 visual index feature may vary, but must be located within the hatched area.
- § Significant Characteristic
- Dimension D does not include mold flash, protrusions or gate burrs, which shall not exceed 0.15 mm per end. Dimension E1 does not include interlead flash or protrusion, which shall not exceed 0.25 mm per side.
- Dimensioning and tolerancing per ASME Y14.5M

BSC: Basic Dimension. Theoretically exact value shown without tolerances.

REF: Reference Dimension, usually without tolerance, for information purposes only.

- Datums A & B to be determined at Datum H.

---



---

## Footprint Outlines and Dimensions

---



---

### 14-Lead Plastic Small Outline (SL) - Narrow, 3.90 mm Body [SOIC]

**Note:** For the most current package drawings, please see the Microchip Packaging Specification located at <http://www.microchip.com/packaging>

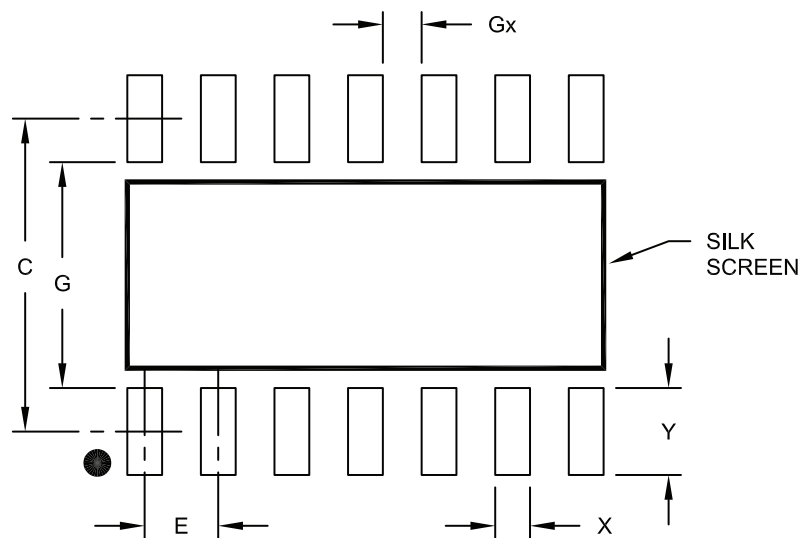

**RECOMMENDED LAND PATTERN**

Dimension Limits	Units	MILLIMETERS		
		MIN	NOM	MAX
Contact Pitch	E	1.27 BSC		
Contact Pad Spacing	C		5.40	
Contact Pad Width	X			0.60
Contact Pad Length	Y			1.50
Distance Between Pads	Gx	0.67		
Distance Between Pads	G	3.90		

**Notes:**

1. Dimensioning and tolerancing per ASME Y14.5M

BSC: Basic Dimension. Theoretically exact value shown without tolerances.

Microchip Technology Drawing No. C04-2065A

**Package Outlines and Dimensions**

**14-Lead Plastic Small Outline (OD) - Narrow, 3.90 mm Body [SOIC]**

**Note:** For the most current package drawings, please see the Microchip Packaging Specification located at <http://www.microchip.com/packaging>

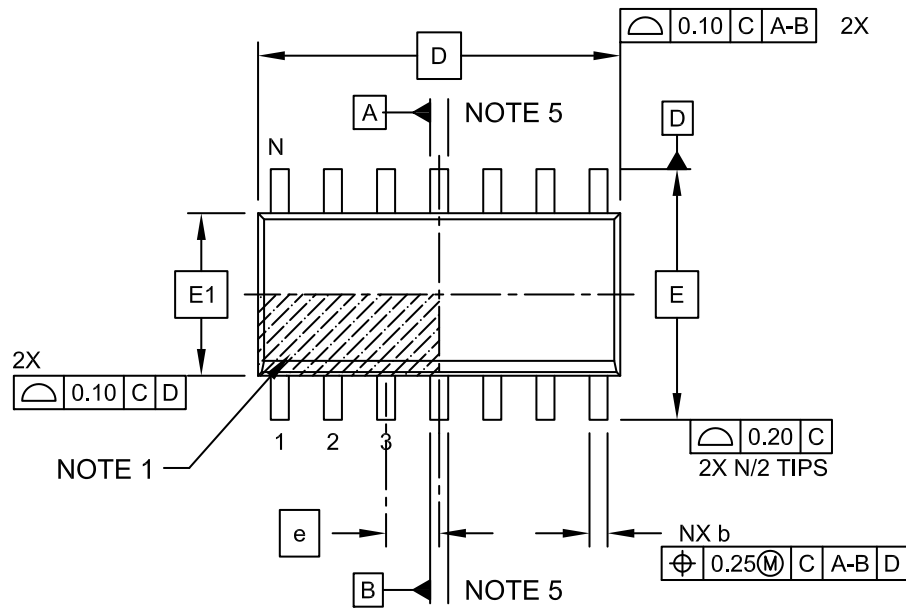

**TOP VIEW**

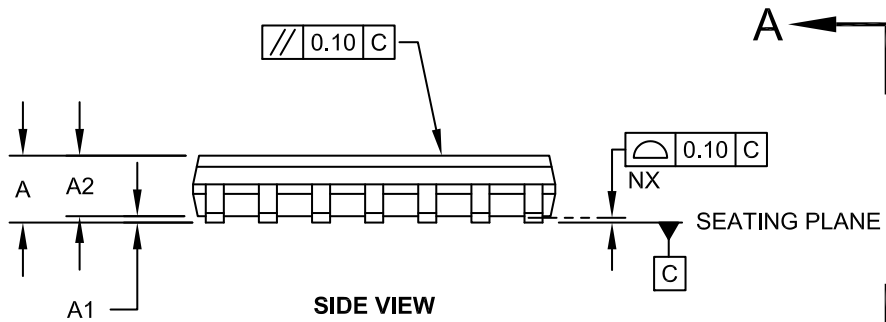

**SIDE VIEW**

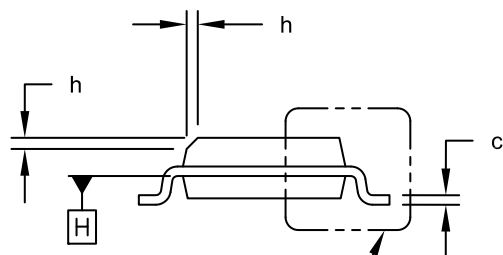

**VIEW A-A**

---



---

## Package Outlines and Dimensions

---



---

### 14-Lead Plastic Small Outline (OD) - Narrow, 3.90 mm Body [SOIC]

**Note:** For the most current package drawings, please see the Microchip Packaging Specification located at <http://www.microchip.com/packaging>

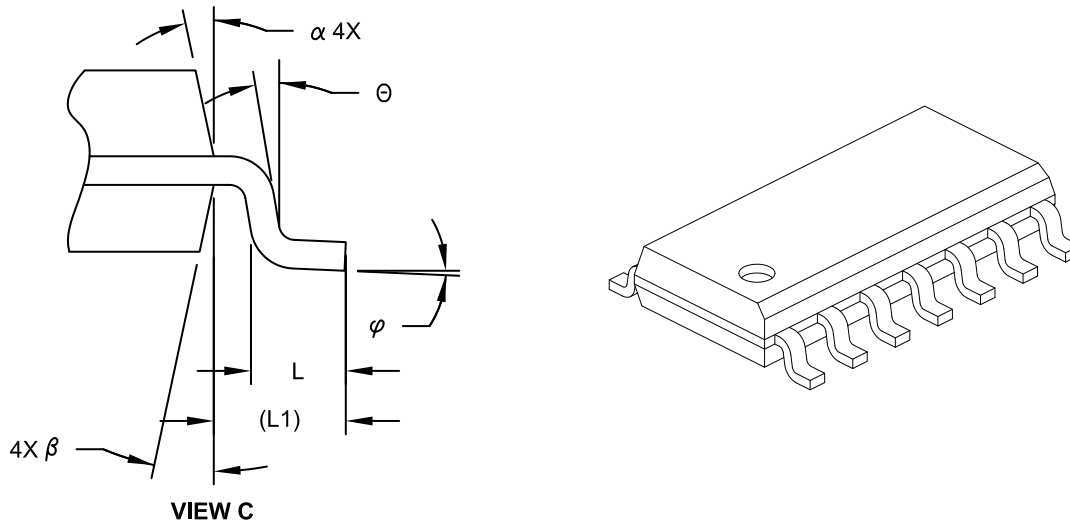

Dimension Limits	Units	MILLIMETERS		
		MIN	NOM	MAX
Number of Pins	N	14		
Pitch	e	1.27 BSC		
Overall Height	A	-	-	1.75
Molded Package Thickness	A2	1.25	-	-
Standoff §	A1	0.10	-	0.25
Overall Width	E	6.00 BSC		
Molded Package Width	E1	3.90 BSC		
Overall Length	D	8.65 BSC		
Chamfer (Optional)	h	0.25	-	0.50
Foot Length	L	0.40	-	1.27
Footprint	L1	1.04 REF		
Lead Angle	θ	0°	-	-
Foot Angle	φ	0°	-	8°
Lead Thickness	c	0.10	-	0.25
Lead Width	b	0.31	-	0.51
Mold Draft Angle Top	α	5°	-	15°
Mold Draft Angle Bottom	β	5°	-	15°

**Notes:**

- Pin 1 visual index feature may vary, but must be located within the hatched area.
- § Significant Characteristic
- Dimension D does not include mold flash, protrusions or gate burrs, which shall not exceed 0.15 mm per end. Dimension E1 does not include interlead flash or protrusion, which shall not exceed 0.25 mm per side.
- Dimensioning and tolerancing per ASME Y14.5M  
 BSC: Basic Dimension. Theoretically exact value shown without tolerances.  
 REF: Reference Dimension, usually without tolerance, for information purposes only.
- Datums A & B to be determined at Datum H.

**Footprint Outlines and Dimensions**

**14-Lead Plastic Small Outline (OD) – Narrow, 3.90 mm Body [SOIC] Land Pattern**

**Note:** For the most current package drawings, please see the Microchip Packaging Specification located at <http://www.microchip.com/packaging>

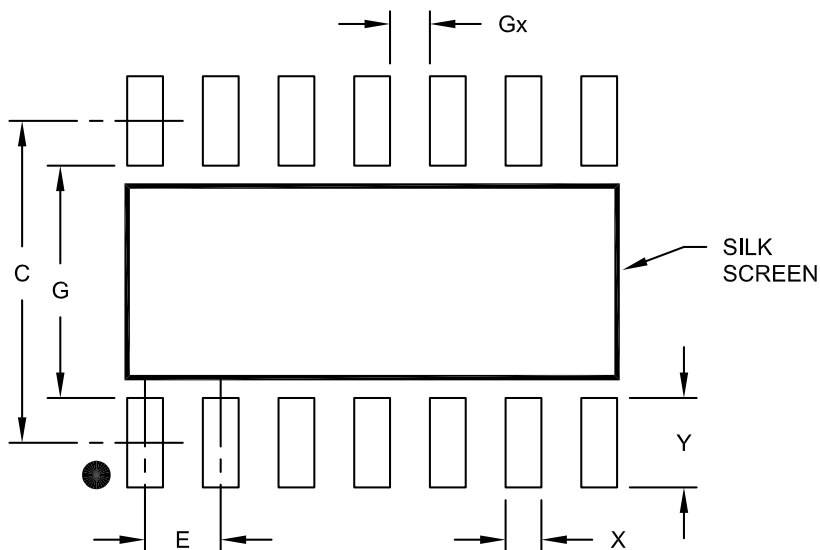

**RECOMMENDED LAND PATTERN**

		Units	MILLIMETERS		
Dimension Limits			MIN	NOM	MAX
Contact Pitch	E		1.27 BSC		
Contact Pad Spacing	C			5.40	
Contact Pad Width	X				0.60
Contact Pad Length	Y				1.50
Distance Between Pads	Gx		0.67		
Distance Between Pads	G		3.90		

Notes:

1. Dimensioning and tolerancing per ASME Y14.5M

BSC: Basic Dimension. Theoretically exact value shown without tolerances.

Microchip Technology Drawing No. C04-2065A



**Package Outlines and Dimensions**

**16-Lead Plastic Small Outline (SL) - Narrow, 3.90 mm Body [SOIC]**

**Note:** For the most current package drawings, please see the Microchip Packaging Specification located at <http://www.microchip.com/packaging>

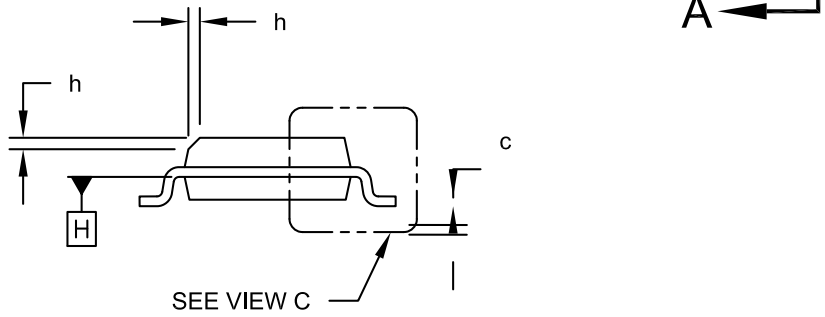
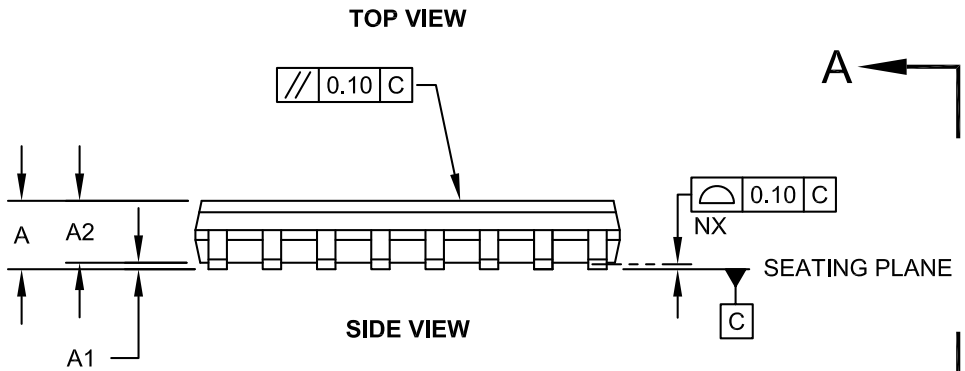
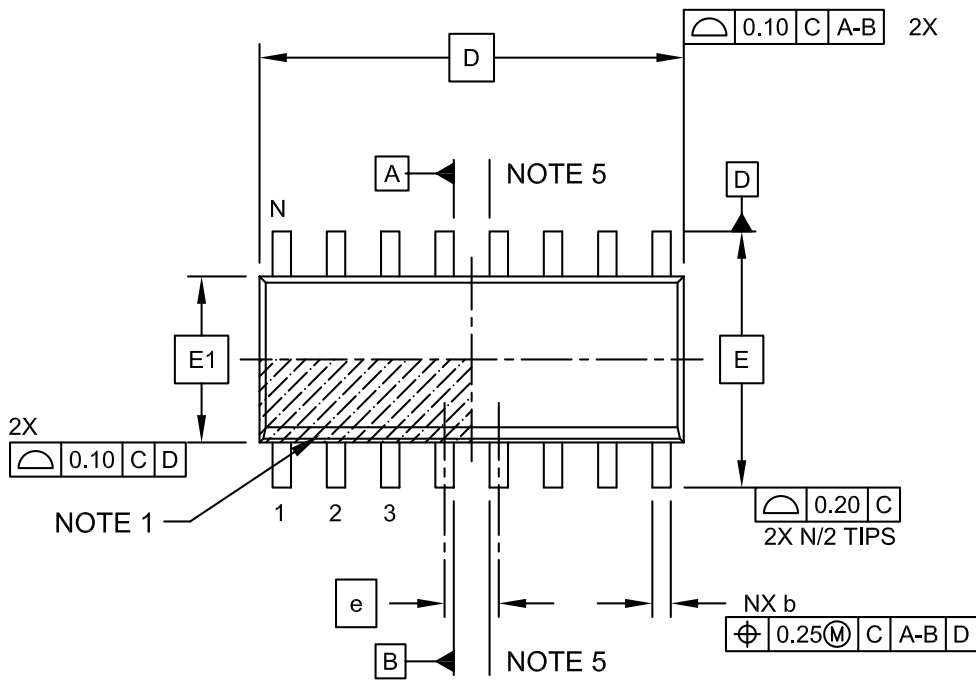

**Package Outlines and Dimensions**

**16-Lead Plastic Small Outline (SL) - Narrow, 3.90 mm Body [SOIC]**

**Note:** For the most current package drawings, please see the Microchip Packaging Specification located at <http://www.microchip.com/packaging>

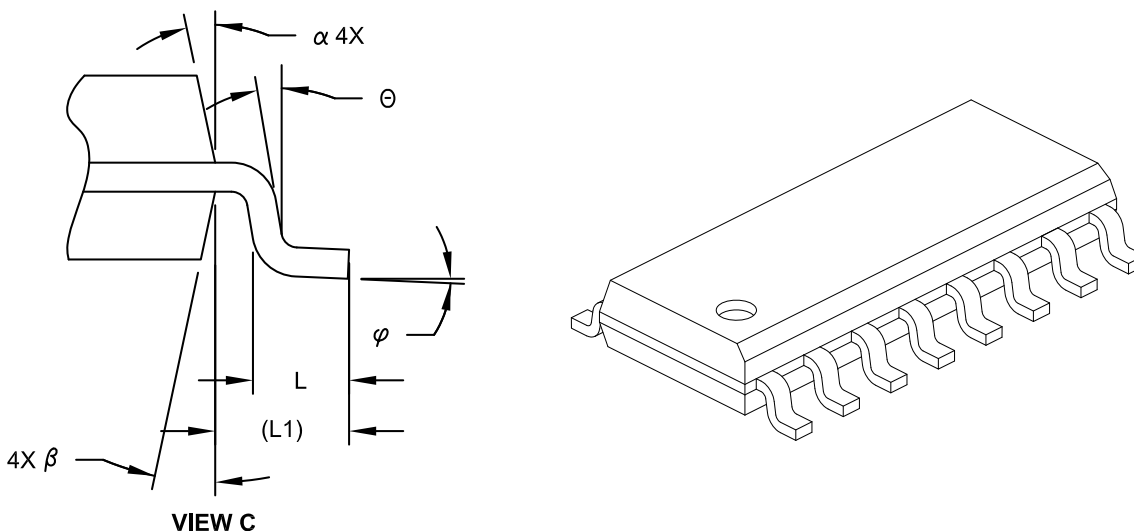

		Units	MILLIMETERS		
Dimension Limits			MIN	NOM	MAX
Number of Pins	N		16		
Pitch	e		1.27 BSC		
Overall Height	A	-	-	-	1.75
Molded Package Thickness	A2	1.25	-	-	-
Standoff §	A1	0.10	-	-	0.25
Overall Width	E		6.00 BSC		
Molded Package Width	E1		3.90 BSC		
Overall Length	D		9.90 BSC		
Chamfer (Optional)	h	0.25	-	-	0.50
Foot Length	L	0.40	-	-	1.27
Footprint	L1		1.04 REF		
Lead Angle	Θ	0°	-	-	-
Foot Angle	φ	0°	-	-	8°
Lead Thickness	c	0.10	-	-	0.25
Lead Width	b	0.31	-	-	0.51
Mold Draft Angle Top	α	5°	-	-	15°
Mold Draft Angle Bottom	β	5°	-	-	15°

**Notes:**

- Pin 1 visual index feature may vary, but must be located within the hatched area.
- § Significant Characteristic
- Dimension D does not include mold flash, protrusions or gate burrs, which shall not exceed 0.15 mm per end. Dimension E1 does not include interlead flash or protrusion, which shall not exceed 0.25 mm per side.
- Dimensioning and tolerancing per ASME Y14.5M  
 BSC: Basic Dimension. Theoretically exact value shown without tolerances.  
 REF: Reference Dimension, usually without tolerance, for information purposes only.
- Datums A & B to be determined at Datum H.

---



---

## Footprint Outlines and Dimensions

---



---

### 16-Lead Plastic Small Outline (SL) - Narrow, 3.90 mm Body [SOIC]

**Note:** For the most current package drawings, please see the Microchip Packaging Specification located at <http://www.microchip.com/packaging>

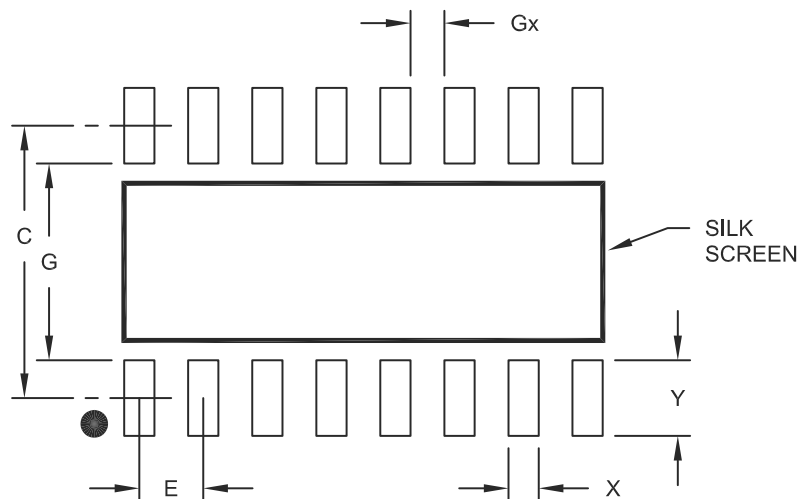

### RECOMMENDED LAND PATTERN

	Units	MILLIMETERS		
		MIN	NOM	MAX
Dimension Limits				
Contact Pitch	E	1.27 BSC		
Contact Pad Spacing	C		5.40	
Contact Pad Width	X			0.60
Contact Pad Length	Y			1.50
Distance Between Pads	Gx	0.67		
Distance Between Pads	G	3.90		

**Notes:**

1. Dimensioning and tolerancing per ASME Y14.5M

BSC: Basic Dimension. Theoretically exact value shown without tolerances.

Microchip Technology Drawing No. C04-2108A

**Package Outlines and Dimensions**

**16-Lead Plastic Small Outline (SO) - Wide, 7.50 mm Body [SOIC]**

**Note:** For the most current package drawings, please see the Microchip Packaging Specification located at <http://www.microchip.com/packaging>

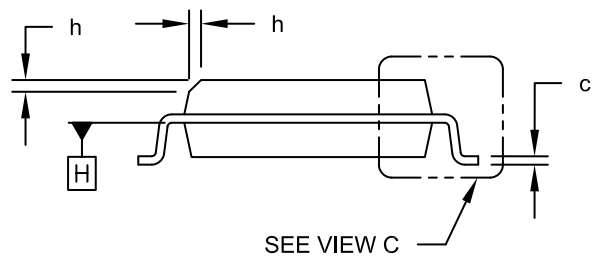
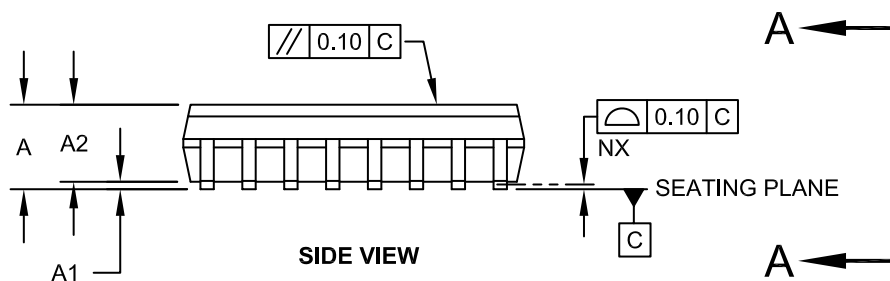
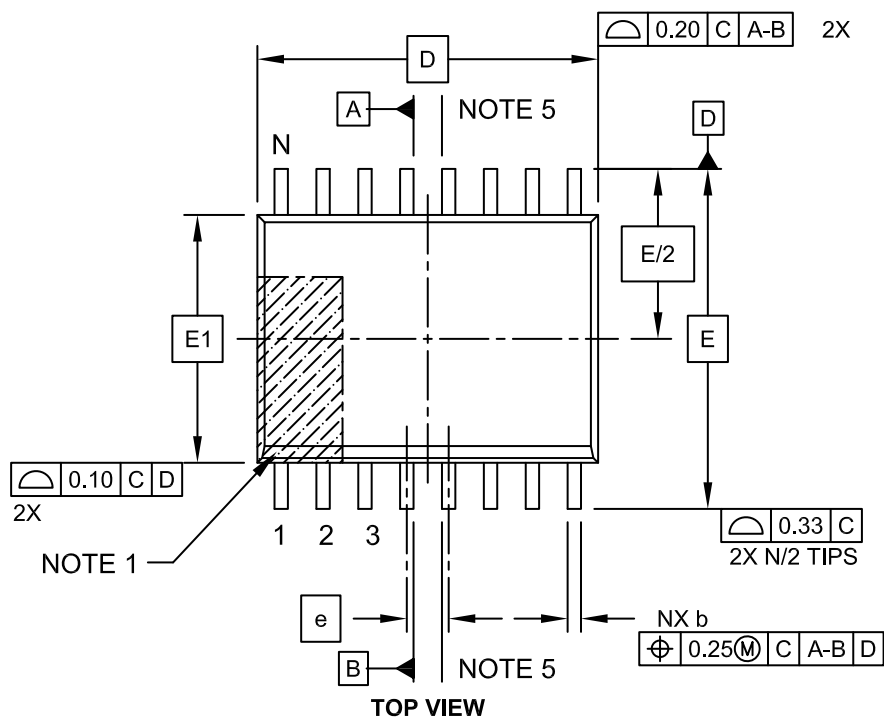

---



---

## Package Outlines and Dimensions

---



---

### 16-Lead Plastic Small Outline (SO) - Wide, 7.50 mm Body [SOIC]

**Note:** For the most current package drawings, please see the Microchip Packaging Specification located at <http://www.microchip.com/packaging>

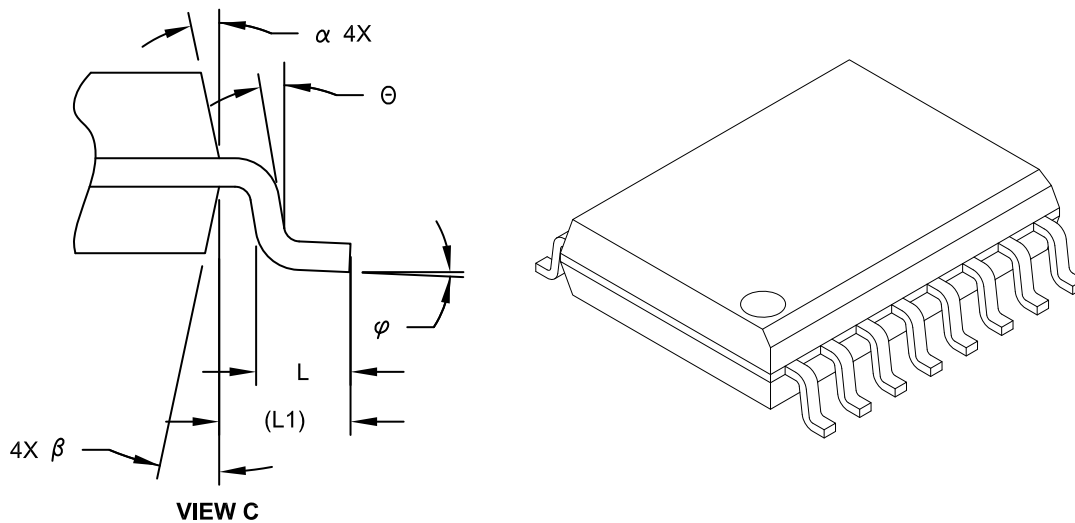

		Units	MILLIMETERS		
Dimension Limits			MIN	NOM	MAX
Number of Pins	N		16		
Pitch	e		1.27 BSC		
Overall Height	A	-	-	-	2.65
Molded Package Thickness	A2	2.05	-	-	-
Standoff §	A1	0.10	-	-	0.30
Overall Width	E		10.30 BSC		
Molded Package Width	E1		7.50 BSC		
Overall Length	D		10.30 BSC		
Chamfer (Optional)	h	0.25	-	-	0.75
Foot Length	L	0.40	-	-	1.27
Footprint	L1		1.40 REF		
Lead Angle	θ	0°	-	-	-
Foot Angle	φ	0°	-	-	8°
Lead Thickness	c	0.20	-	-	0.33
Lead Width	b	0.31	-	-	0.51
Mold Draft Angle Top	α	5°	-	-	15°
Mold Draft Angle Bottom	β	5°	-	-	15°

**Notes:**

1. Pin 1 visual index feature may vary, but must be located within the hatched area.
2. § Significant Characteristic
3. Dimension D does not include mold flash, protrusions or gate burrs, which shall not exceed 0.15 mm per end. Dimension E1 does not include interlead flash or protrusion, which shall not exceed 0.25 mm per side.
4. Dimensioning and tolerancing per ASME Y14.5M
  - BSC: Basic Dimension. Theoretically exact value shown without tolerances.
  - REF: Reference Dimension, usually without tolerance, for information purposes only.
5. Datums A & B to be determined at Datum H.

**Footprint Outlines and Dimensions**

**16-Lead Plastic Small Outline (SO) – Wide, 7.50 mm Body [SOIC] Land Pattern**

**Note:** For the most current package drawings, please see the Microchip Packaging Specification located at <http://www.microchip.com/packaging>

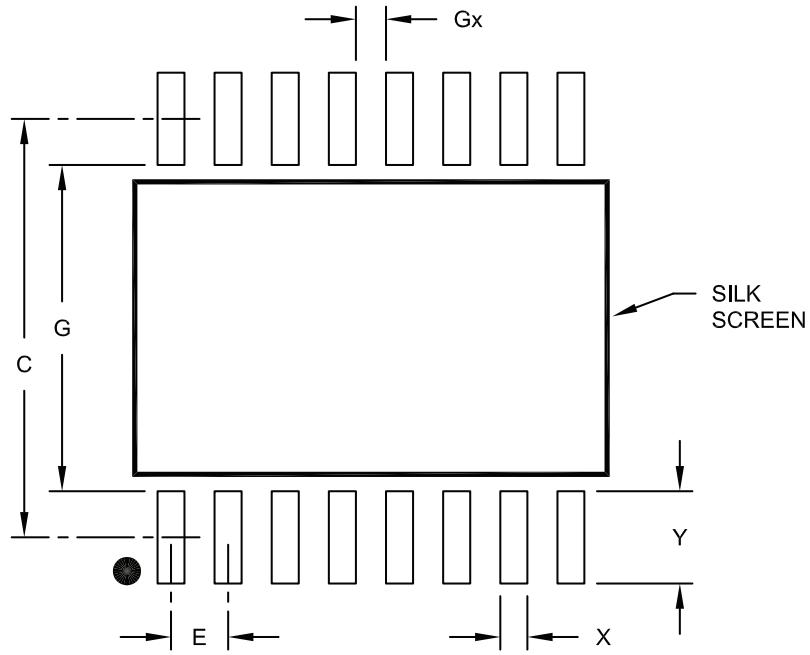

RECOMMENDED LAND PATTERN

		Units	MILLIMETERS		
Dimension Limits			MIN	NOM	MAX
Contact Pitch	E		1.27 BSC		
Contact Pad Spacing	C			9.30	
Contact Pad Width	X				0.60
Contact Pad Length	Y				2.05
Distance Between Pads	Gx		0.67		
Distance Between Pads	G		7.25		

Notes:

1. Dimensioning and tolerancing per ASME Y14.5M

BSC: Basic Dimension. Theoretically exact value shown without tolerances.

Microchip Technology Drawing No. C04-2102A

**Package Outlines and Dimensions**

**16-Lead Plastic Small Outline (OE) - Wide, 7.50 mm Body [SOIC]**

**Note:** For the most current package drawings, please see the Microchip Packaging Specification located at <http://www.microchip.com/packaging>

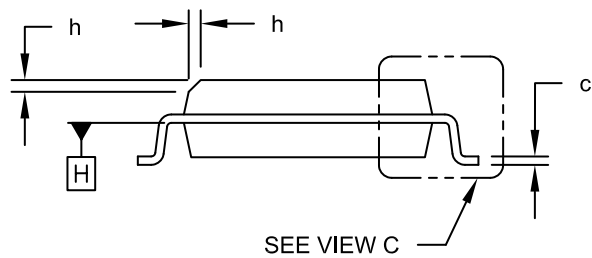
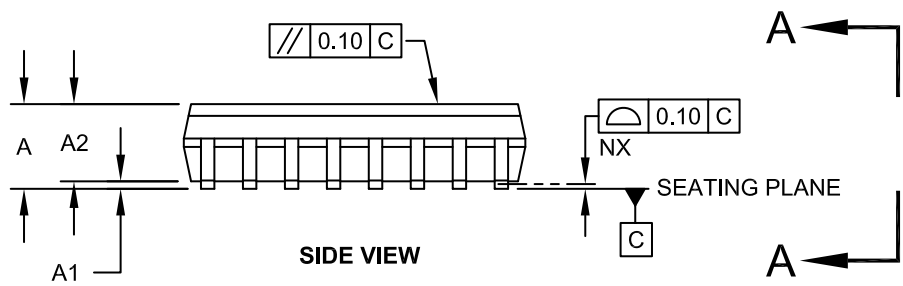
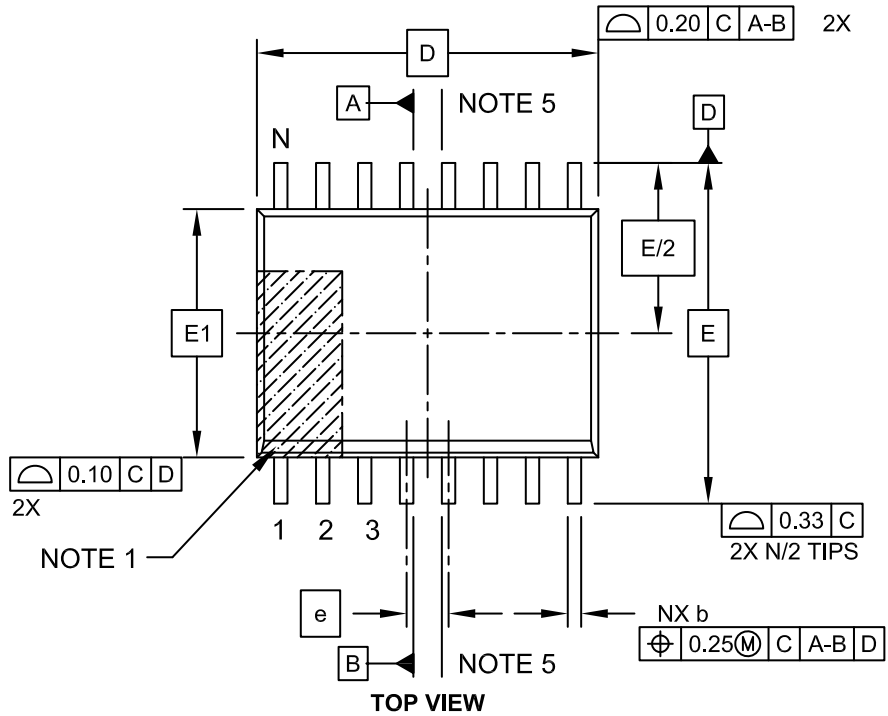

**Package Outlines and Dimensions**

**16-Lead Plastic Small Outline (OE) - Wide, 7.50 mm Body [SOIC]**

**Note:** For the most current package drawings, please see the Microchip Packaging Specification located at <http://www.microchip.com/packaging>

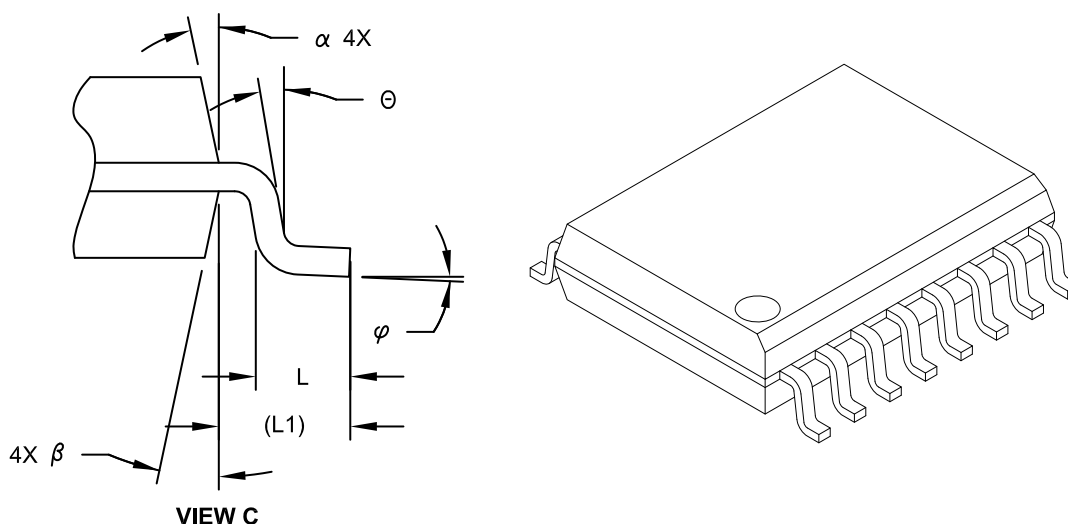

		Units	MILLIMETERS		
Dimension Limits			MIN	NOM	MAX
Number of Pins	N		16		
Pitch	e		1.27 BSC		
Overall Height	A	-	-	-	2.65
Molded Package Thickness	A2	2.05	-	-	-
Standoff §	A1	0.10	-	-	0.30
Overall Width	E		10.30 BSC		
Molded Package Width	E1		7.50 BSC		
Overall Length	D		10.30 BSC		
Chamfer (Optional)	h	0.25	-	-	0.75
Foot Length	L	0.40	-	-	1.27
Footprint	L1		1.40 REF		
Lead Angle	Θ	0°	-	-	-
Foot Angle	φ	0°	-	-	8°
Lead Thickness	c	0.20	-	-	0.33
Lead Width	b	0.31	-	-	0.51
Mold Draft Angle Top	α	5°	-	-	15°
Mold Draft Angle Bottom	β	5°	-	-	15°

**Notes:**

- Pin 1 visual index feature may vary, but must be located within the hatched area.
- § Significant Characteristic
- Dimension D does not include mold flash, protrusions or gate burrs, which shall not exceed 0.15 mm per end. Dimension E1 does not include interlead flash or protrusion, which shall not exceed 0.25 mm per side.
- Dimensioning and tolerancing per ASME Y14.5M  
 BSC: Basic Dimension. Theoretically exact value shown without tolerances.  
 REF: Reference Dimension, usually without tolerance, for information purposes only.
- Datums A & B to be determined at Datum H.



---



---

## Footprint Outlines and Dimensions

---



---

### 16-Lead Plastic Small Outline (OE) – Wide, 7.50 mm Body [SOIC] Land Pattern

**Note:** For the most current package drawings, please see the Microchip Packaging Specification located at <http://www.microchip.com/packaging>

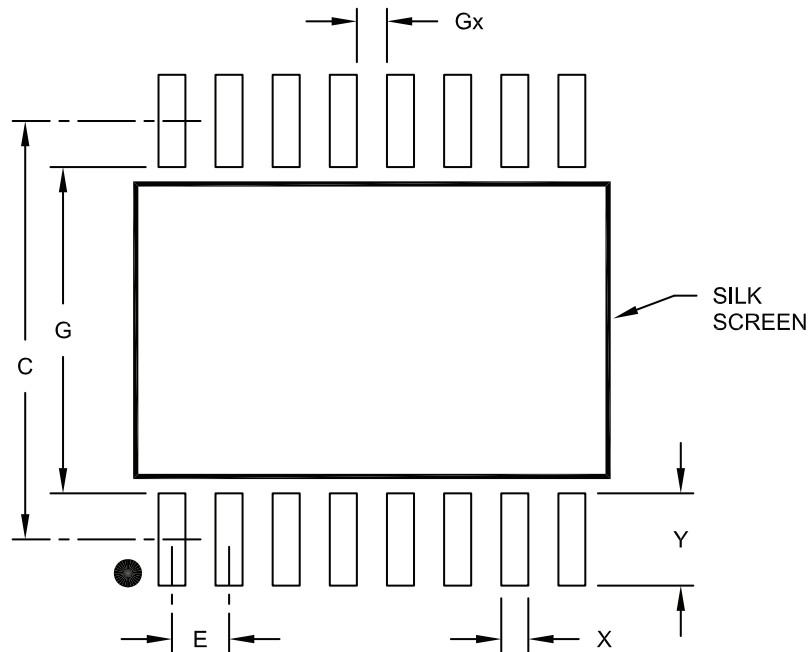

RECOMMENDED LAND PATTERN

		Units	MILLIMETERS		
		Dimension Limits	MIN	NOM	MAX
Contact Pitch	E	1.27 BSC			
Contact Pad Spacing	C		9.30		
Contact Pad Width	X				0.60
Contact Pad Length	Y				2.05
Distance Between Pads	Gx	0.67			
Distance Between Pads	G	7.25			

**Notes:**

1. Dimensioning and tolerancing per ASME Y14.5M

BSC: Basic Dimension. Theoretically exact value shown without tolerances.

Microchip Technology Drawing No. C04-2102A

**Package Outlines and Dimensions**

**18-Lead Plastic Small Outline (SO) - Wide, 7.50 mm Body [SOIC]**

**Note:** For the most current package drawings, please see the Microchip Packaging Specification located at <http://www.microchip.com/packaging>

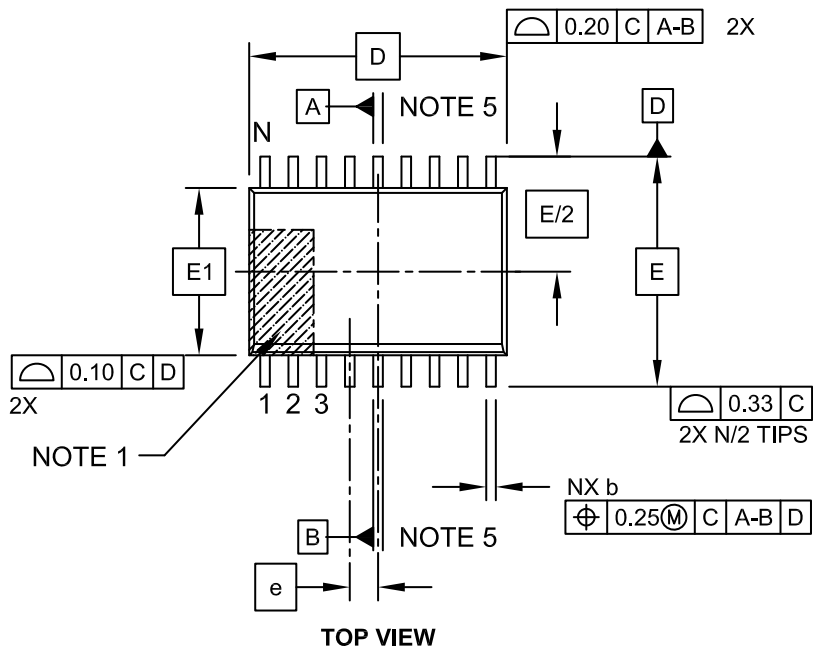

**TOP VIEW**

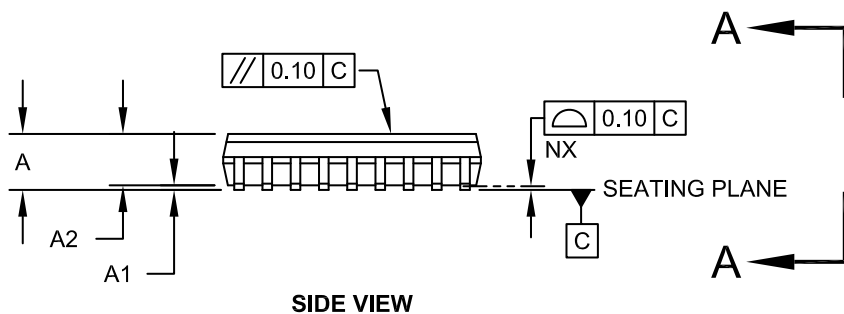

**SIDE VIEW**

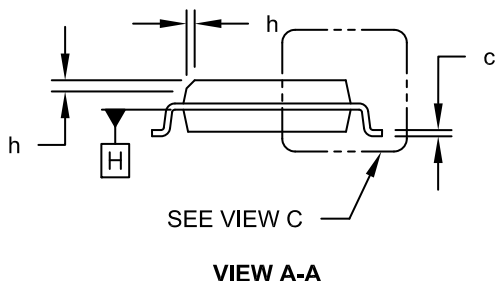

**VIEW A-A**

---



---

## Package Outlines and Dimensions

---



---

### 18-Lead Plastic Small Outline (SO) - Wide, 7.50 mm Body [SOIC]

**Note:** For the most current package drawings, please see the Microchip Packaging Specification located at <http://www.microchip.com/packaging>

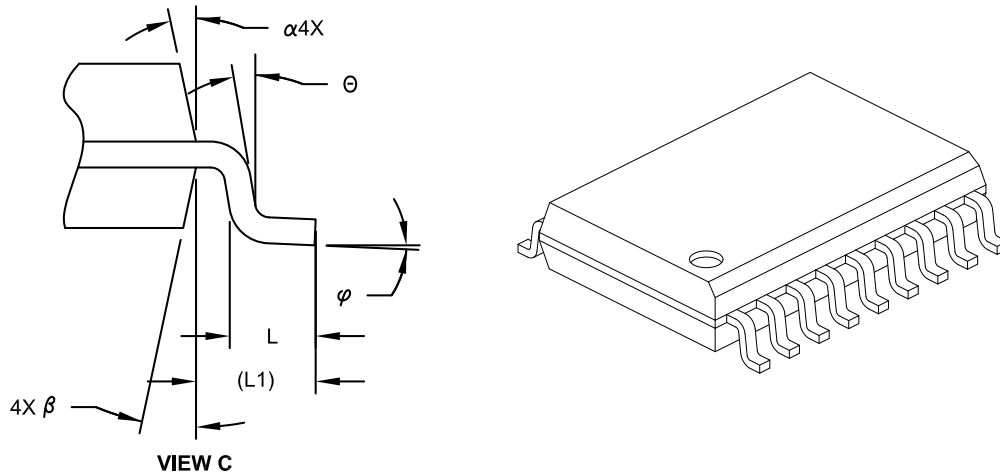

Dimension Limits	Units	MILLIMETERS		
		MIN	NOM	MAX
Number of Pins	N	18		
Pitch	e	1.27 BSC		
Overall Height	A	-	-	2.65
Molded Package Thickness	A2	2.05	-	-
Standoff §	A1	0.10	-	0.30
Overall Width	E	10.30 BSC		
Molded Package Width	E1	7.50 BSC		
Overall Length	D	11.55 BSC		
Chamfer (Optional)	h	0.25	-	0.75
Foot Length	L	0.40	-	1.27
Footprint	L1	1.40 REF		
Lead Angle	θ	0°	-	-
Foot Angle	φ	0°	-	8°
Lead Thickness	c	0.20	-	0.33
Lead Width	b	0.31	-	0.51
Mold Draft Angle Top	α	5°	-	15°
Mold Draft Angle Bottom	β	5°	-	15°

**Notes:**

1. Pin 1 visual index feature may vary, but must be located within the hatched area.
2. § Significant Characteristic
3. Dimension D does not include mold flash, protrusions or gate burrs, which shall not exceed 0.15 mm per end. Dimension E1 does not include interlead flash or protrusion, which shall not exceed 0.25 mm per side.
4. Dimensioning and tolerancing per ASME Y14.5M  
 BSC: Basic Dimension. Theoretically exact value shown without tolerances.  
 REF: Reference Dimension, usually without tolerance, for information purposes only.
5. Datums A & B to be determined at Datum H.

**Footprint Outlines and Dimensions**

18-Lead Plastic Small Outline (SO) - Wide, 7.50 mm Body [SOIC]

**Note:** For the most current package drawings, please see the Microchip Packaging Specification located at <http://www.microchip.com/packaging>

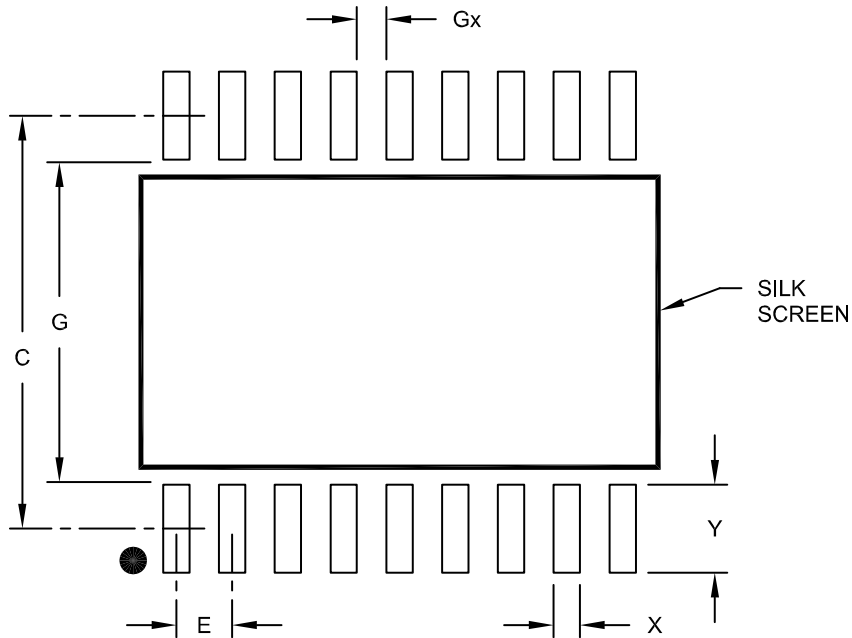

RECOMMENDED LAND PATTERN

Dimension Limits	Units	MILLIMETERS		
		MIN	NOM	MAX
Contact Pitch	E	1.27 BSC		
Contact Pad Spacing	C		9.40	
Contact Pad Width	X			0.60
Contact Pad Length	Y			2.00
Distance Between Pads	Gx	0.67		
Distance Between Pads	G	7.40		

Notes:

1. Dimensioning and tolerancing per ASME Y14.5M

BSC: Basic Dimension. Theoretically exact value shown without tolerances.

Microchip Technology Drawing No. C04-2051A

**Package Outlines and Dimensions**

**20-Lead Plastic Small Outline (SO) - Wide, 7.50 mm Body [SOIC]**

**Note:** For the most current package drawings, please see the Microchip Packaging Specification located at <http://www.microchip.com/packaging>

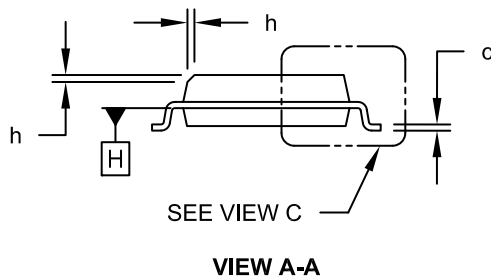
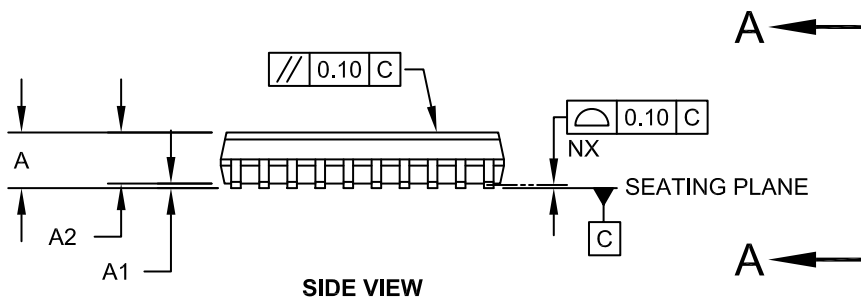
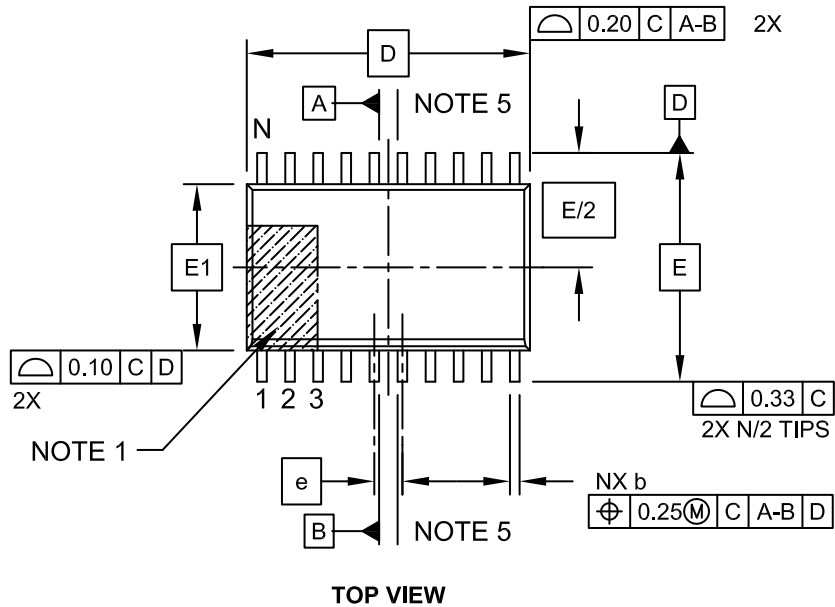

**Package Outlines and Dimensions**

**20-Lead Plastic Small Outline (SO) - Wide, 7.50 mm Body [SOIC]**

**Note:** For the most current package drawings, please see the Microchip Packaging Specification located at <http://www.microchip.com/packaging>

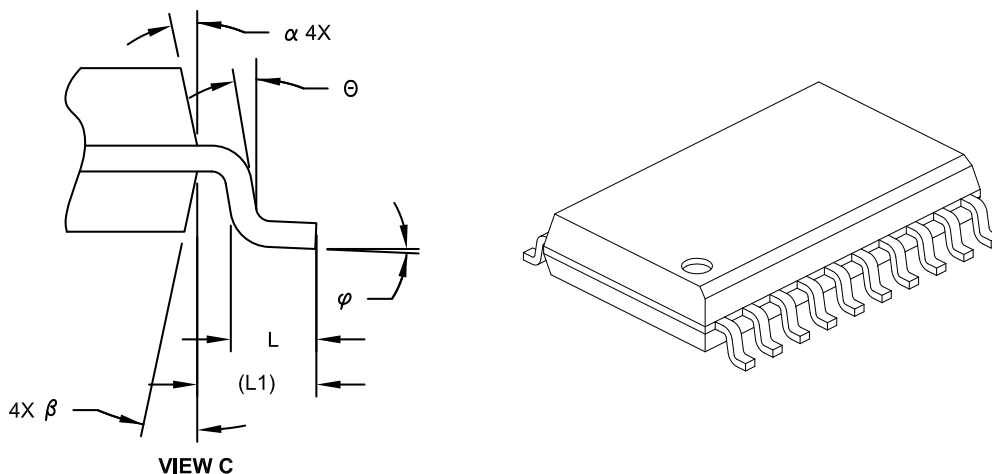

Dimension Limits	Units	MILLIMETERS		
		MIN	NOM	MAX
Number of Pins	N	20		
Pitch	e	1.27 BSC		
Overall Height	A	-	-	2.65
Molded Package Thickness	A2	2.05	-	-
Standoff §	A1	0.10	-	0.30
Overall Width	E	10.30 BSC		
Molded Package Width	E1	7.50 BSC		
Overall Length	D	12.80 BSC		
Chamfer (Optional)	h	0.25	-	0.75
Foot Length	L	0.40	-	1.27
Footprint	L1	1.40 REF		
Lead Angle	$\Theta$	0°	-	-
Foot Angle	$\phi$	0°	-	8°
Lead Thickness	c	0.20	-	0.33
Lead Width	b	0.31	-	0.51
Mold Draft Angle Top	$\alpha$	5°	-	15°
Mold Draft Angle Bottom	$\beta$	5°	-	15°

**Notes:**

- Pin 1 visual index feature may vary, but must be located within the hatched area.
- § Significant Characteristic
- Dimension D does not include mold flash, protrusions or gate burrs, which shall not exceed 0.15 mm per end. Dimension E1 does not include interlead flash or protrusion, which shall not exceed 0.25 mm per side.
- Dimensioning and tolerancing per ASME Y14.5M  
 BSC: Basic Dimension. Theoretically exact value shown without tolerances.  
 REF: Reference Dimension, usually without tolerance, for information purposes only.
- Datums A & B to be determined at Datum H.

---



---

## Footprint Outlines and Dimensions

---



---

### 20-Lead Plastic Small Outline (SO) - Wide, 7.50 mm Body [SOIC]

**Note:** For the most current package drawings, please see the Microchip Packaging Specification located at <http://www.microchip.com/packaging>

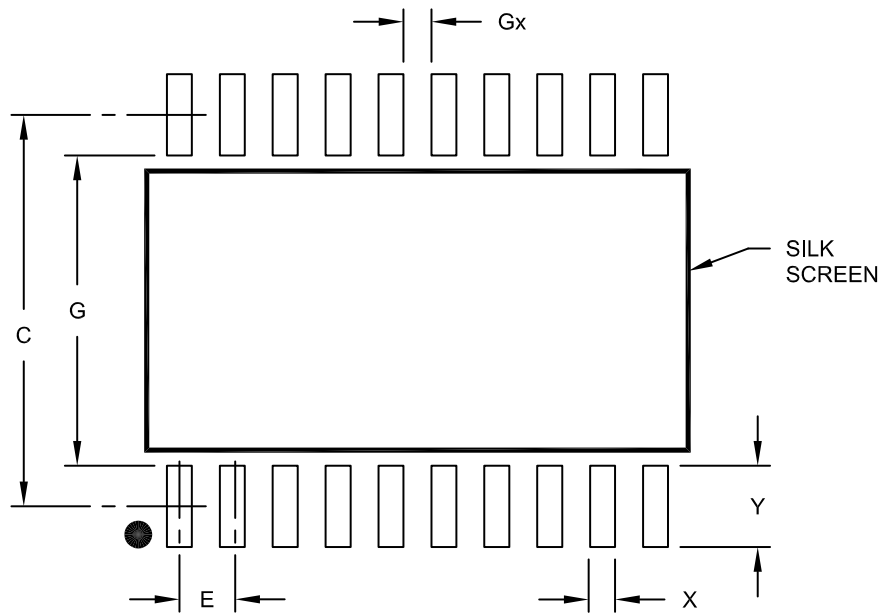

RECOMMENDED LAND PATTERN

Dimension Limits	Units	MILLIMETERS		
		MIN	NOM	MAX
Contact Pitch	E	1.27 BSC		
Contact Pad Spacing	C		9.40	
Contact Pad Width (X20)	X			0.60
Contact Pad Length (X20)	Y			1.95
Distance Between Pads	Gx	0.67		
Distance Between Pads	G	7.45		

**Notes:**

1. Dimensioning and tolerancing per ASME Y14.5M

BSC: Basic Dimension. Theoretically exact value shown without tolerances.

Microchip Technology Drawing No. C04-2094A

**Package Outlines and Dimensions**

**24-Lead Plastic Small Outline (SO) - Wide, 7.50 mm Body [SOIC]**

**Note:** For the most current package drawings, please see the Microchip Packaging Specification located at <http://www.microchip.com/packaging>

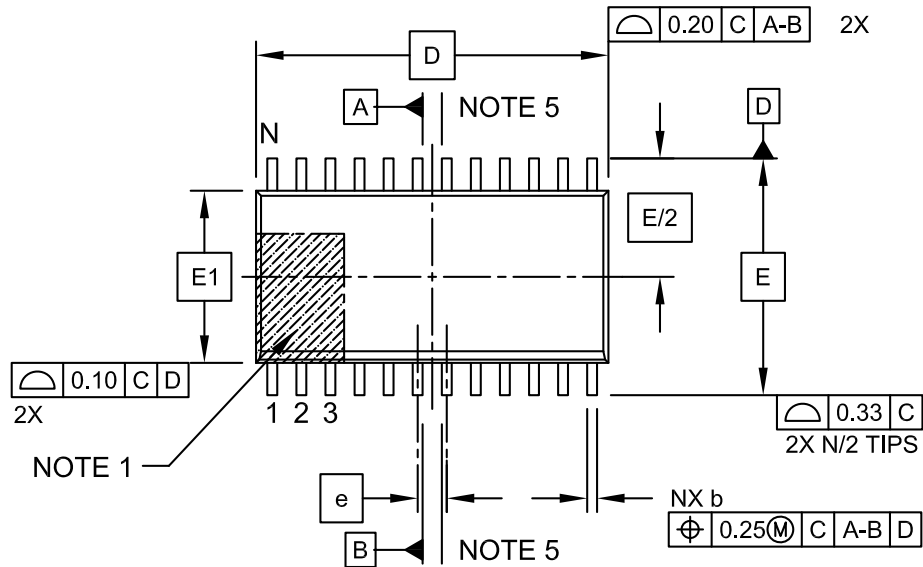

**TOP VIEW**



**SIDE VIEW**

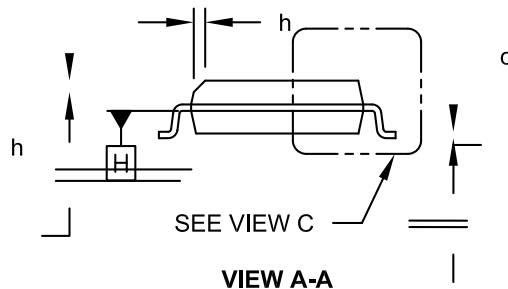

**VIEW A-A**



---



---

## Package Outlines and Dimensions

---



---

### 24-Lead Plastic Small Outline (SO) - Wide, 7.50 mm Body [SOIC]

**Note:** For the most current package drawings, please see the Microchip Packaging Specification located at <http://www.microchip.com/packaging>

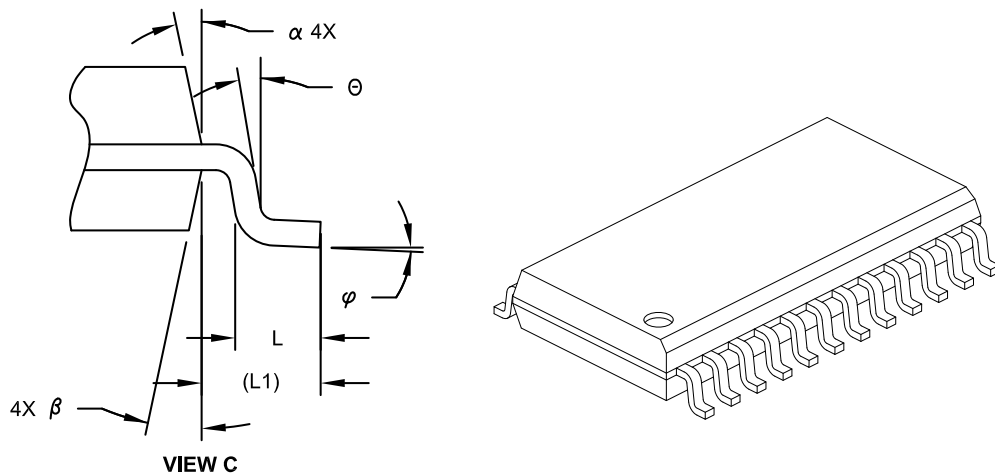

		MILLIMETERS		
Units				
Dimension Limits		MIN	NOM	MAX
Number of Pins	N	24		
Pitch	e	1.27 BSC		
Overall Height	A	-	-	2.65
Molded Package Thickness	A2	2.05	-	-
Standoff §	A1	0.10	-	0.30
Overall Width	E	10.30 BSC		
Molded Package Width	E1	7.50 BSC		
Overall Length	D	15.40 BSC		
Chamfer (Optional)	h	0.25	-	0.75
Foot Length	L	0.40	-	1.27
Footprint	L1	1.40 REF		
Lead Angle	Θ	0°	-	-
Foot Angle	φ	0°	-	8°
Lead Thickness	c	0.20	-	0.33
Lead Width	b	0.31	-	0.51
Mold Draft Angle Top	α	5°	-	15°
Mold Draft Angle Bottom	β	5°	-	15°

**Notes:**

1. Pin 1 visual index feature may vary, but must be located within the hatched area.
2. § Significant Characteristic
3. Dimension D does not include mold flash, protrusions or gate burrs, which shall not exceed 0.15 mm per end. Dimension E1 does not include interlead flash or protrusion, which shall not exceed 0.25 mm per side.
4. Dimensioning and tolerancing per ASME Y14.5M  
 BSC: Basic Dimension. Theoretically exact value shown without tolerances.  
 REF: Reference Dimension, usually without tolerance, for information purposes only.
5. Datums A & B to be determined at Datum H.

**Footprint Outlines and Dimensions**

**24-Lead Plastic Small Outline (SO) – Wide, 7.50 mm Body [SOIC]**

**Note:** For the most current package drawings, please see the Microchip Packaging Specification located at <http://www.microchip.com/packaging>

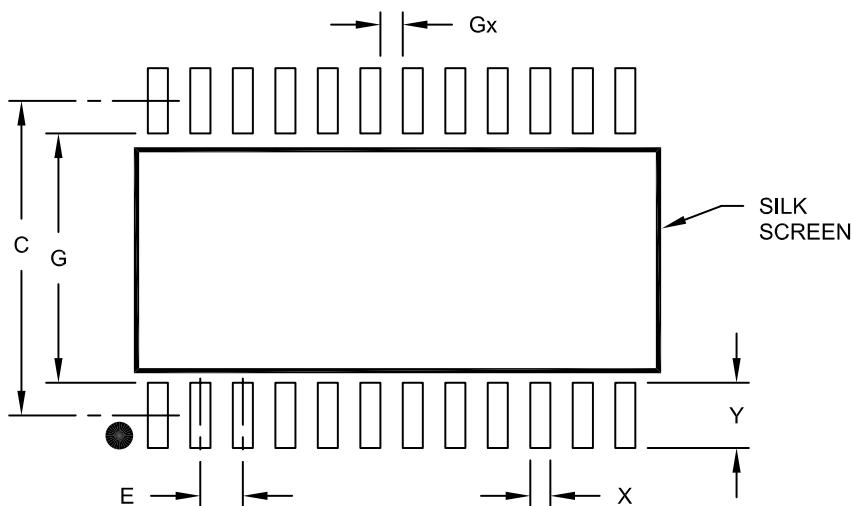

**RECOMMENDED LAND PATTERN**

Dimension Limits	Units	MILLIMETERS		
		MIN	NOM	MAX
Contact Pitch	E	1.27 BSC		
Contact Pad Spacing	C		9.40	
Contact Pad Width (X24)	X			0.60
Contact Pad Length (X24)	Y			2.00
Distance Between Pads	Gx	0.67		
Distance Between Pads	G	7.40		

Notes:

1. Dimensioning and tolerancing per ASME Y14.5M

BSC: Basic Dimension. Theoretically exact value shown without tolerances.

Microchip Technology Drawing No. C04-2025A

**Package Outlines and Dimensions**

**24-Lead Plastic Small Outline (OG) - Wide, 7.50 mm Body [SOIC]**

**Note:** For the most current package drawings, please see the Microchip Packaging Specification located at <http://www.microchip.com/packaging>

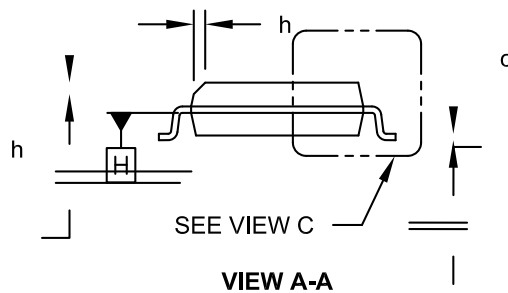
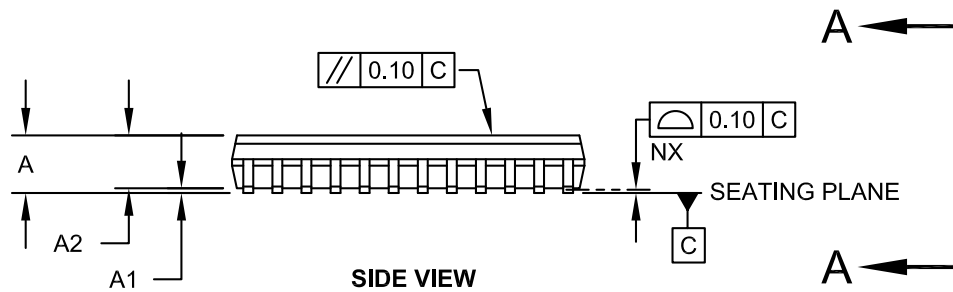
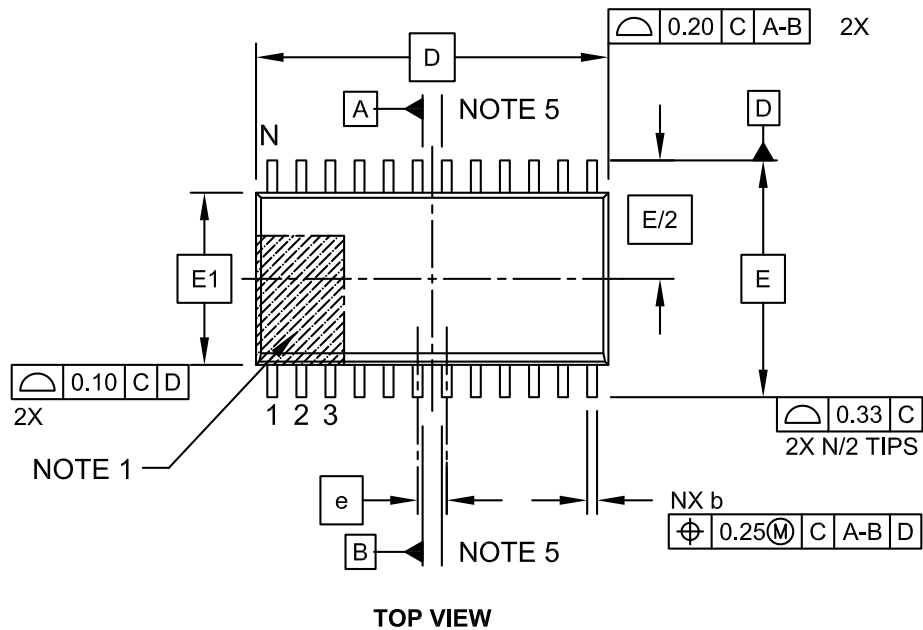

**Package Outlines and Dimensions**

**24-Lead Plastic Small Outline (OG) - Wide, 7.50 mm Body [SOIC]**

**Note:** For the most current package drawings, please see the Microchip Packaging Specification located at <http://www.microchip.com/packaging>

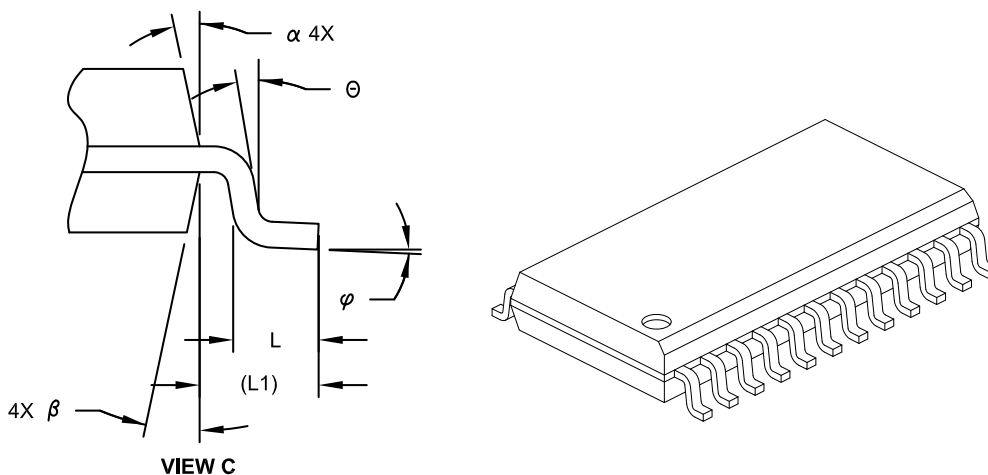

Dimension Limits	Units	MILLIMETERS		
		MIN	NOM	MAX
Number of Pins	N	24		
Pitch	e	1.27 BSC		
Overall Height	A	-	-	2.65
Molded Package Thickness	A2	2.05	-	-
Standoff §	A1	0.10	-	0.30
Overall Width	E	10.30 BSC		
Molded Package Width	E1	7.50 BSC		
Overall Length	D	15.40 BSC		
Chamfer (Optional)	h	0.25	-	0.75
Foot Length	L	0.40	-	1.27
Footprint	L1	1.40 REF		
Lead Angle	Θ	0°	-	-
Foot Angle	φ	0°	-	8°
Lead Thickness	c	0.20	-	0.33
Lead Width	b	0.31	-	0.51
Mold Draft Angle Top	α	5°	-	15°
Mold Draft Angle Bottom	β	5°	-	15°

**Notes:**

- Pin 1 visual index feature may vary, but must be located within the hatched area.
- § Significant Characteristic
- Dimension D does not include mold flash, protrusions or gate burrs, which shall not exceed 0.15 mm per end. Dimension E1 does not include interlead flash or protrusion, which shall not exceed 0.25 mm per side.
- Dimensioning and tolerancing per ASME Y14.5M  
 BSC: Basic Dimension. Theoretically exact value shown without tolerances.  
 REF: Reference Dimension, usually without tolerance, for information purposes only.
- Datums A & B to be determined at Datum H.

---



---

## Footprint Outlines and Dimensions

---



---

### 24-Lead Plastic Small Outline (OG) – Wide, 7.50 mm Body [SOIC]

**Note:** For the most current package drawings, please see the Microchip Packaging Specification located at <http://www.microchip.com/packaging>

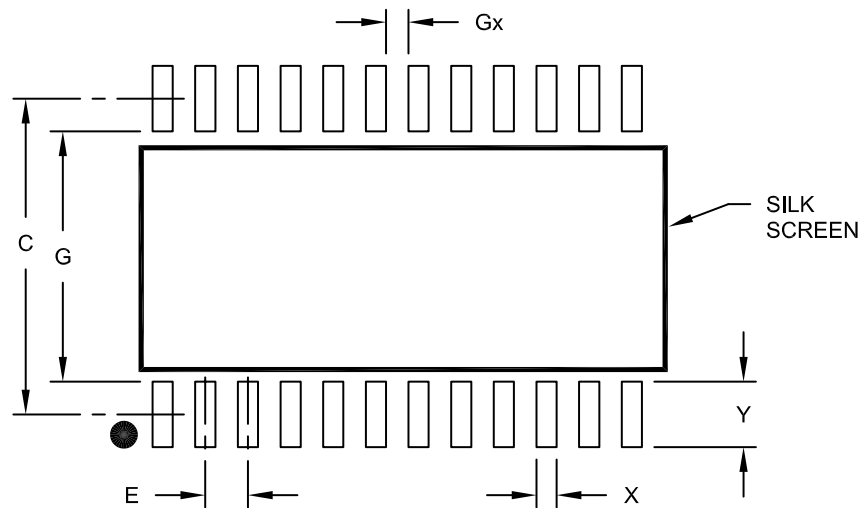

RECOMMENDED LAND PATTERN

	Units	MILLIMETERS		
		MIN	NOM	MAX
Contact Pitch	E	1.27 BSC		
Contact Pad Spacing	C		9.40	
Contact Pad Width (X24)	X			0.60
Contact Pad Length (X24)	Y			2.00
Distance Between Pads	Gx	0.67		
Distance Between Pads	G	7.40		

**Notes:**

1. Dimensioning and tolerancing per ASME Y14.5M

BSC: Basic Dimension. Theoretically exact value shown without tolerances.

Microchip Technology Drawing No. C04-2025A

**Package Outlines and Dimensions**

**28-Lead Plastic Small Outline (SO) - Wide, 7.50 mm Body [SOIC]**

**Note:** For the most current package drawings, please see the Microchip Packaging Specification located at <http://www.microchip.com/packaging>

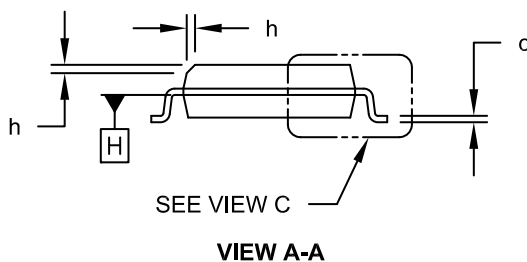
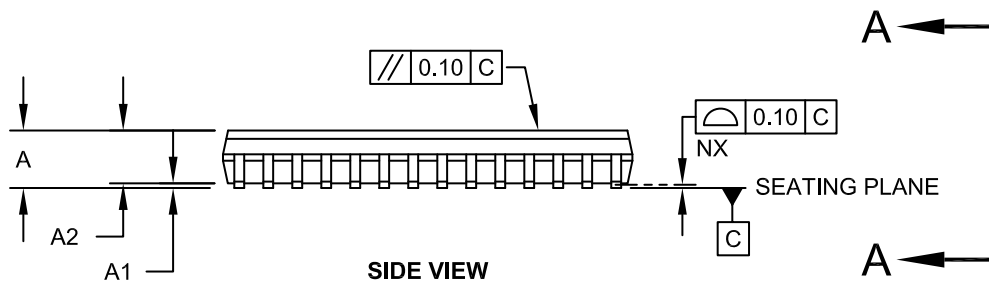
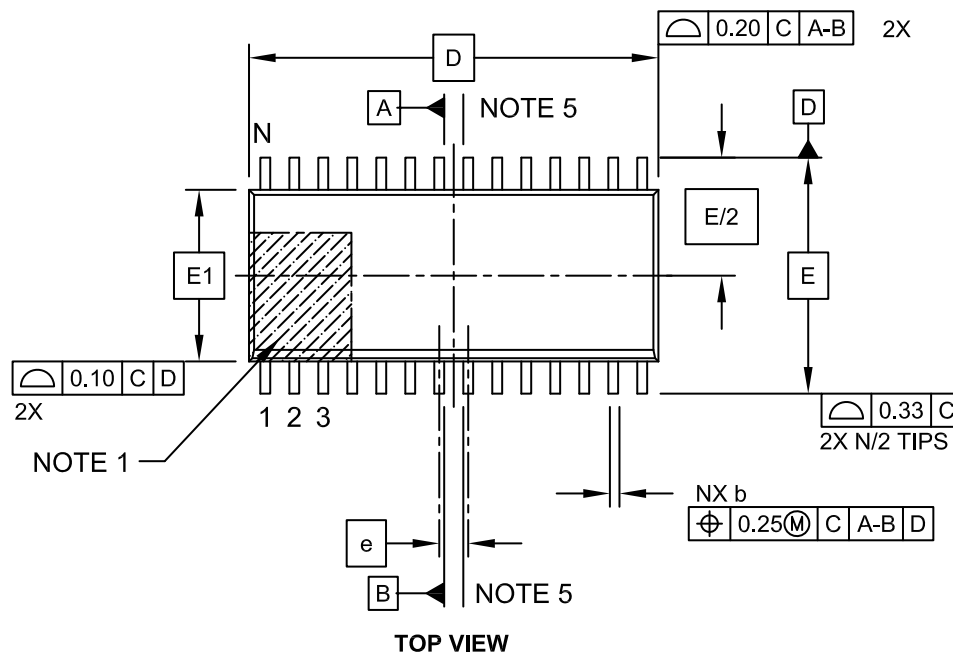

---



---

## Package Outlines and Dimensions

---



---

### 28-Lead Plastic Small Outline (SO) - Wide, 7.50 mm Body [SOIC]

**Note:** For the most current package drawings, please see the Microchip Packaging Specification located at <http://www.microchip.com/packaging>

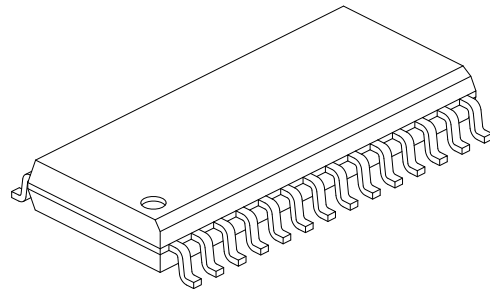
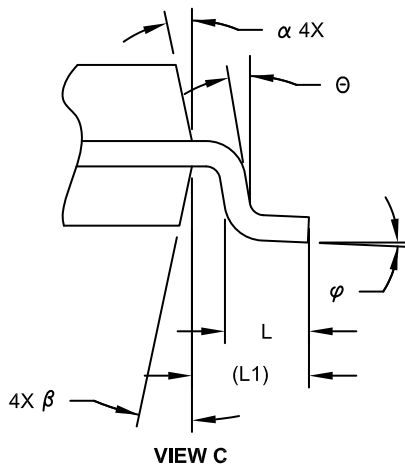

Dimension Limits	Units	MILLIMETERS		
		MIN	NOM	MAX
Number of Pins	N	28		
Pitch	e	1.27 BSC		
Overall Height	A	-	-	2.65
Molded Package Thickness	A2	2.05	-	-
Standoff §	A1	0.10	-	0.30
Overall Width	E	10.30 BSC		
Molded Package Width	E1	7.50 BSC		
Overall Length	D	17.90 BSC		
Chamfer (Optional)	h	0.25	-	0.75
Foot Length	L	0.40	-	1.27
Footprint	L1	1.40 REF		
Lead Angle	θ	0°	-	-
Foot Angle	φ	0°	-	8°
Lead Thickness	c	0.18	-	0.33
Lead Width	b	0.31	-	0.51
Mold Draft Angle Top	α	5°	-	15°
Mold Draft Angle Bottom	β	5°	-	15°

**Notes:**

1. Pin 1 visual index feature may vary, but must be located within the hatched area.
2. § Significant Characteristic
3. Dimension D does not include mold flash, protrusions or gate burrs, which shall not exceed 0.15 mm per end. Dimension E1 does not include interlead flash or protrusion, which shall not exceed 0.25 mm per side.
4. Dimensioning and tolerancing per ASME Y14.5M
  - BSC: Basic Dimension. Theoretically exact value shown without tolerances.
  - REF: Reference Dimension, usually without tolerance, for information purposes only.
5. Datums A & B to be determined at Datum H.

**Footprint Outlines and Dimensions**

28-Lead Plastic Small Outline (SO) - Wide, 7.50 mm Body [SOIC]

**Note:** For the most current package drawings, please see the Microchip Packaging Specification located at <http://www.microchip.com/packaging>

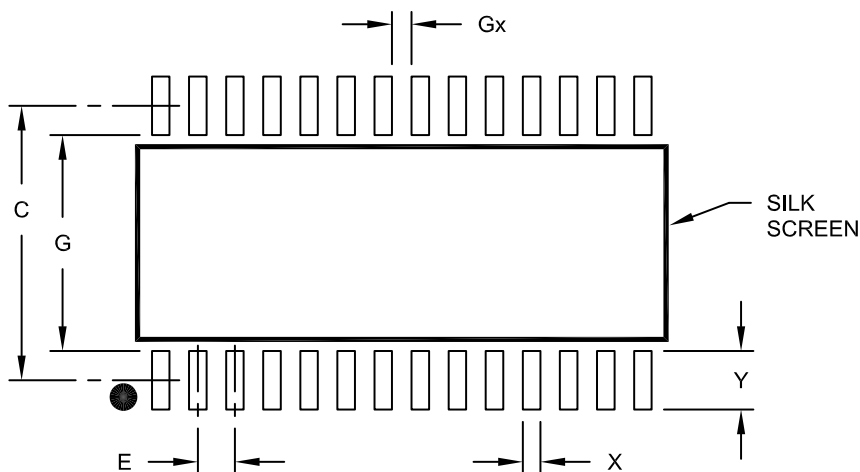

**RECOMMENDED LAND PATTERN**

Dimension Limits	Units	MILLIMETERS		
		MIN	NOM	MAX
Contact Pitch	E	1.27 BSC		
Contact Pad Spacing	C		9.40	
Contact Pad Width (X28)	X			0.60
Contact Pad Length (X28)	Y			2.00
Distance Between Pads	Gx	0.67		
Distance Between Pads	G	7.40		

Notes:

1. Dimensioning and tolerancing per ASME Y14.5M

BSC: Basic Dimension. Theoretically exact value shown without tolerances.

Microchip Technology Drawing No. C04-2052A



**Package Outlines and Dimensions**

**28-Lead Plastic Small Outline (OI) - Wide, 7.50 mm Body [SOIC]**

**Note:** For the most current package drawings, please see the Microchip Packaging Specification located at <http://www.microchip.com/packaging>

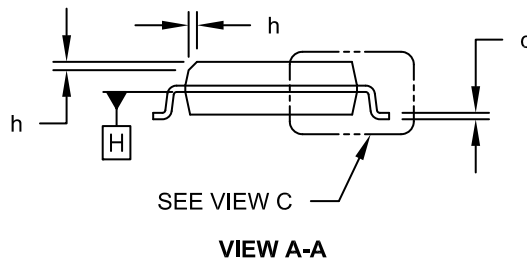
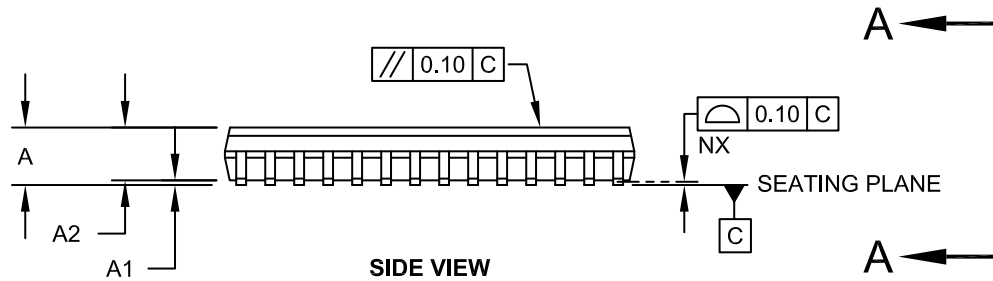
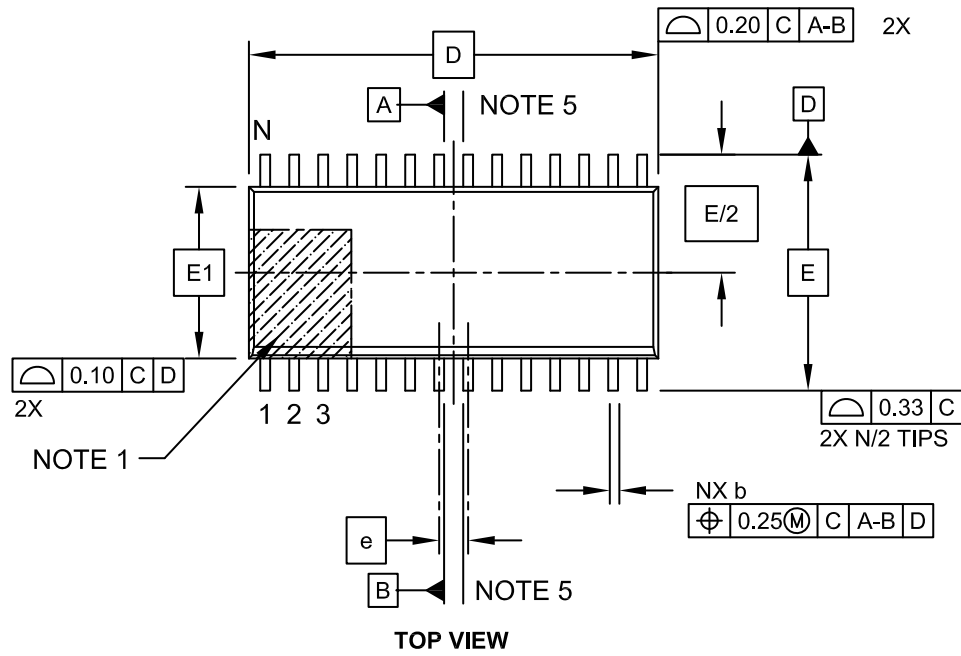

**Package Outlines and Dimensions**

**28-Lead Plastic Small Outline (OI) - Wide, 7.50 mm Body [SOIC]**

**Note:** For the most current package drawings, please see the Microchip Packaging Specification located at <http://www.microchip.com/packaging>

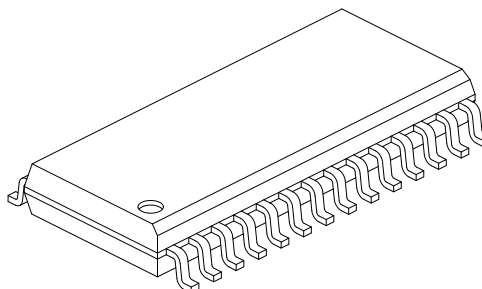
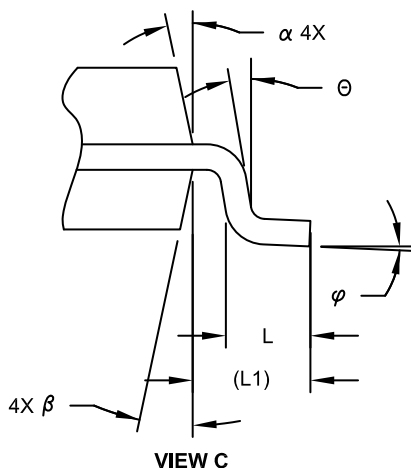

		Units	MILLIMETERS		
Dimension Limits			MIN	NOM	MAX
Number of Pins	N		28		
Pitch	e		1.27 BSC		
Overall Height	A	-	-	-	2.65
Molded Package Thickness	A2	2.05	-	-	-
Standoff §	A1	0.10	-	-	0.30
Overall Width	E		10.30 BSC		
Molded Package Width	E1		7.50 BSC		
Overall Length	D		17.90 BSC		
Chamfer (Optional)	h	0.25	-	-	0.75
Foot Length	L	0.40	-	-	1.27
Footprint	L1		1.40 REF		
Lead Angle	θ	0°	-	-	-
Foot Angle	φ	0°	-	-	8°
Lead Thickness	c	0.18	-	-	0.33
Lead Width	b	0.31	-	-	0.51
Mold Draft Angle Top	α	5°	-	-	15°
Mold Draft Angle Bottom	β	5°	-	-	15°

**Notes:**

- Pin 1 visual index feature may vary, but must be located within the hatched area.
- § Significant Characteristic
- Dimension D does not include mold flash, protrusions or gate burrs, which shall not exceed 0.15 mm per end. Dimension E1 does not include interlead flash or protrusion, which shall not exceed 0.25 mm per side.
- Dimensioning and tolerancing per ASME Y14.5M  
 BSC: Basic Dimension. Theoretically exact value shown without tolerances.  
 REF: Reference Dimension, usually without tolerance, for information purposes only.
- Datums A & B to be determined at Datum H.

---



---

## Footprint Outlines and Dimensions

---



---

### 28-Lead Plastic Small Outline (OI) - Wide, 7.50 mm Body [SOIC]

**Note:** For the most current package drawings, please see the Microchip Packaging Specification located at <http://www.microchip.com/packaging>

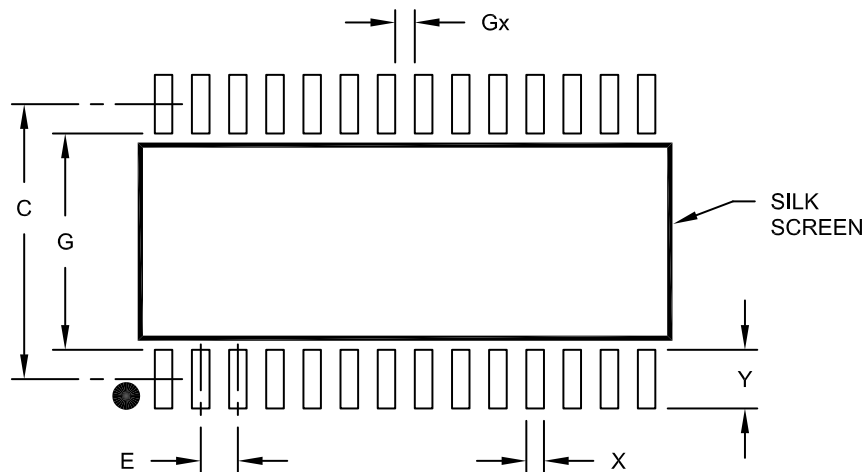

### RECOMMENDED LAND PATTERN

		MILLIMETERS		
		MIN	NOM	MAX
Contact Pitch	E	1.27 BSC		
Contact Pad Spacing	C		9.40	
Contact Pad Width (X28)	X			0.60
Contact Pad Length (X28)	Y			2.00
Distance Between Pads	Gx	0.67		
Distance Between Pads	G	7.40		

**Notes:**

1. Dimensioning and tolerancing per ASME Y14.5M

BSC: Basic Dimension. Theoretically exact value shown without tolerances.

Microchip Technology Drawing No. C04-2052A



**MICROCHIP**

---

---

**Package Outlines and Dimensions**

---

---

NOTES:

---

---

**Package Outlines and Dimensions**

---

---

**SOIJ**

**Package Outlines and Dimensions**

**8-Lead Plastic Small Outline (SM) - Medium, 5.28 mm Body [SOIJ]**

**Note:** For the most current package drawings, please see the Microchip Packaging Specification located at <http://www.microchip.com/packaging>

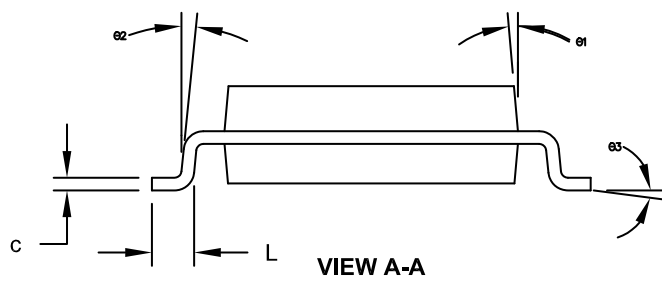
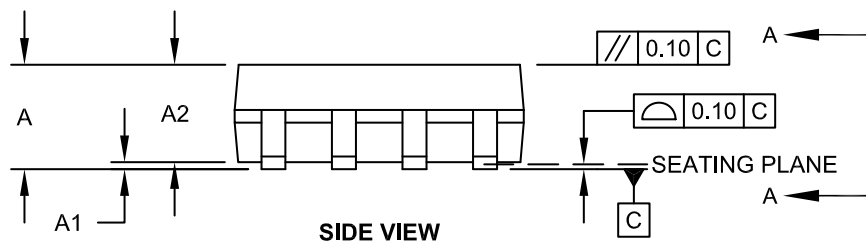
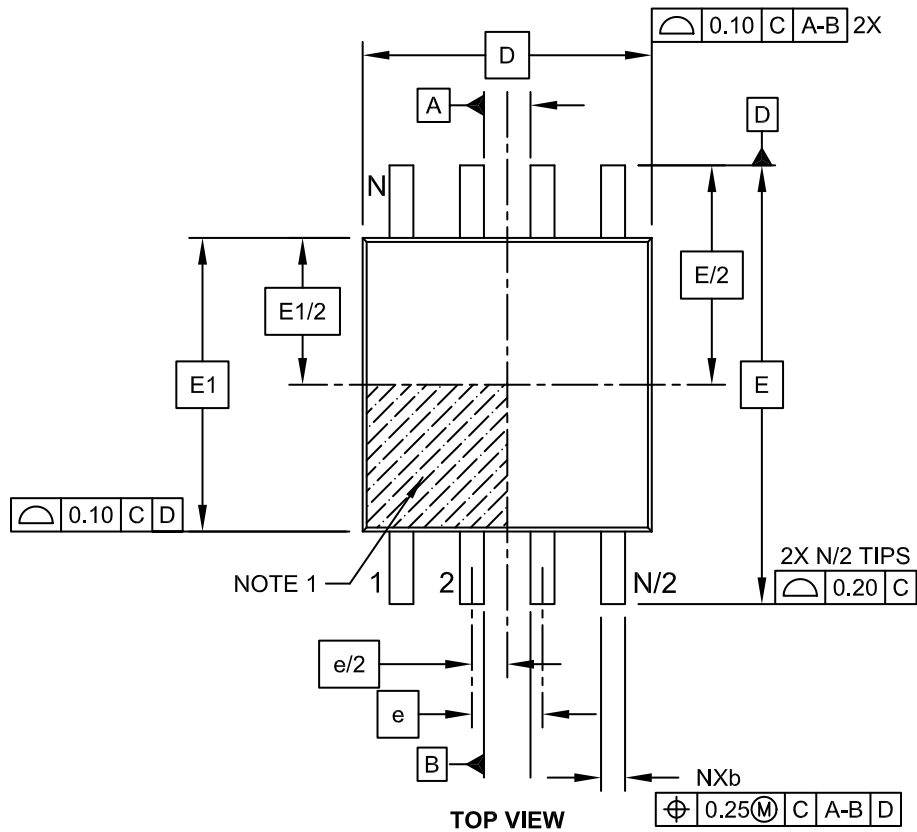

---



---

## Package Outlines and Dimensions

---



---

### 8-Lead Plastic Small Outline (SM) - Medium, 5.28 mm Body [SOIJ]

**Note:** For the most current package drawings, please see the Microchip Packaging Specification located at <http://www.microchip.com/packaging>

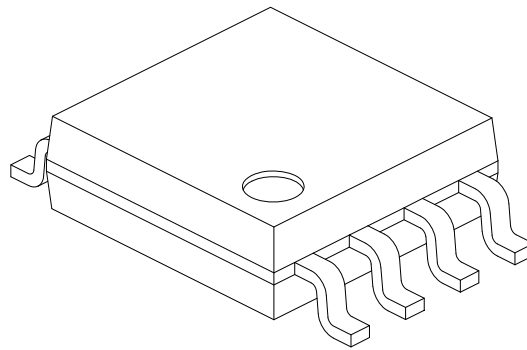

Dimension Limits	Units	MILLIMETERS		
		MIN	NOM	MAX
Number of Pins	N	8		
Pitch	e	1.27 BSC		
Overall Height	A	1.77	-	2.03
Standoff §	A1	0.05		0.25
Molded Package Thickness	A2	1.75	-	1.98
Overall Width	E	7.94 BSC		
Molded Package Width	E1	5.25 BSC		
Overall Length	D	5.26 BSC		
Foot Length	L	0.51	-	0.76
Lead Thickness	c	0.15	-	0.25
Lead Width	b	0.36	-	0.51
Mold Draft Angle	Ø1	-	-	15°
Lead Angle	Ø2	0°	-	8°
Foot Angle	Ø3	0°	-	8°

**Notes:**

1. SOIJ, JEITA/EIAJ Standard, Formerly called SOIC
2. § Significant Characteristic
3. Dimensions D and E1 do not include mold flash or protrusions. Mold flash or protrusions shall not exceed 0.25mm per side.

**Footprint Outlines and Dimensions**

8-Lead Plastic Small Outline (SM) - Medium, 5.28 mm Body [SOIJ]

**Note:** For the most current package drawings, please see the Microchip Packaging Specification located at <http://www.microchip.com/packaging>

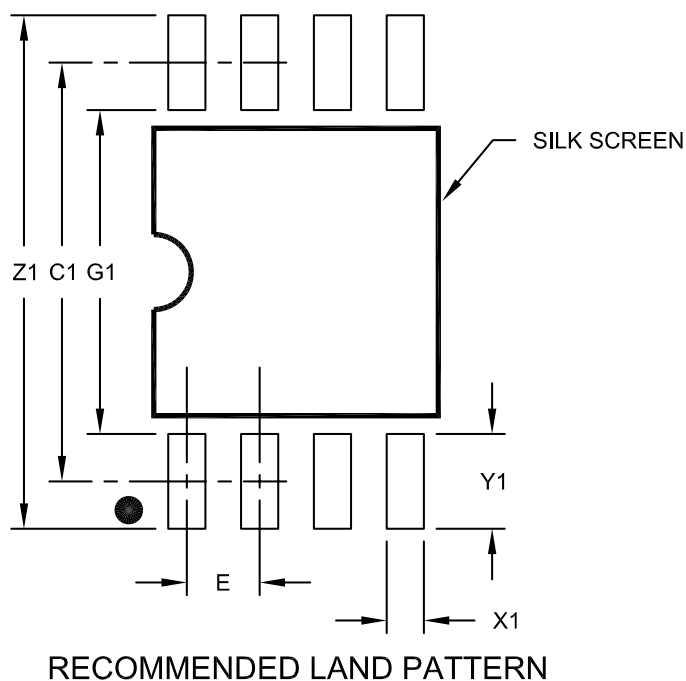

Dimension Limits	Units	MILLIMETERS		
		MIN	NOM	MAX
Contact Pitch	E	1.27 BSC		
Overall Width	Z1			9.00
Contact Pad Spacing	C1		7.30	
Contact Pad Width (X8)	X1			0.65
Contact Pad Length (X8)	Y1			1.70
Distance Between Pads	G1	5.60		
Distance Between Pads	G	0.62		

Notes:

1. Dimensioning and tolerancing per ASME Y14.5M

BSC: Basic Dimension. Theoretically exact value shown without tolerances.

Microchip Technology Drawing No. C04-2056C



---

---

**Package Outlines and Dimensions**

---

---

**DFN**

**Package Outlines and Dimensions**

**6-Lead Plastic Dual Flat, No Lead Package (MA[Y]) - 2x2x0.9mm Body [DFN]**

**Note:** For the most current package drawings, please see the Microchip Packaging Specification located at <http://www.microchip.com/packaging>

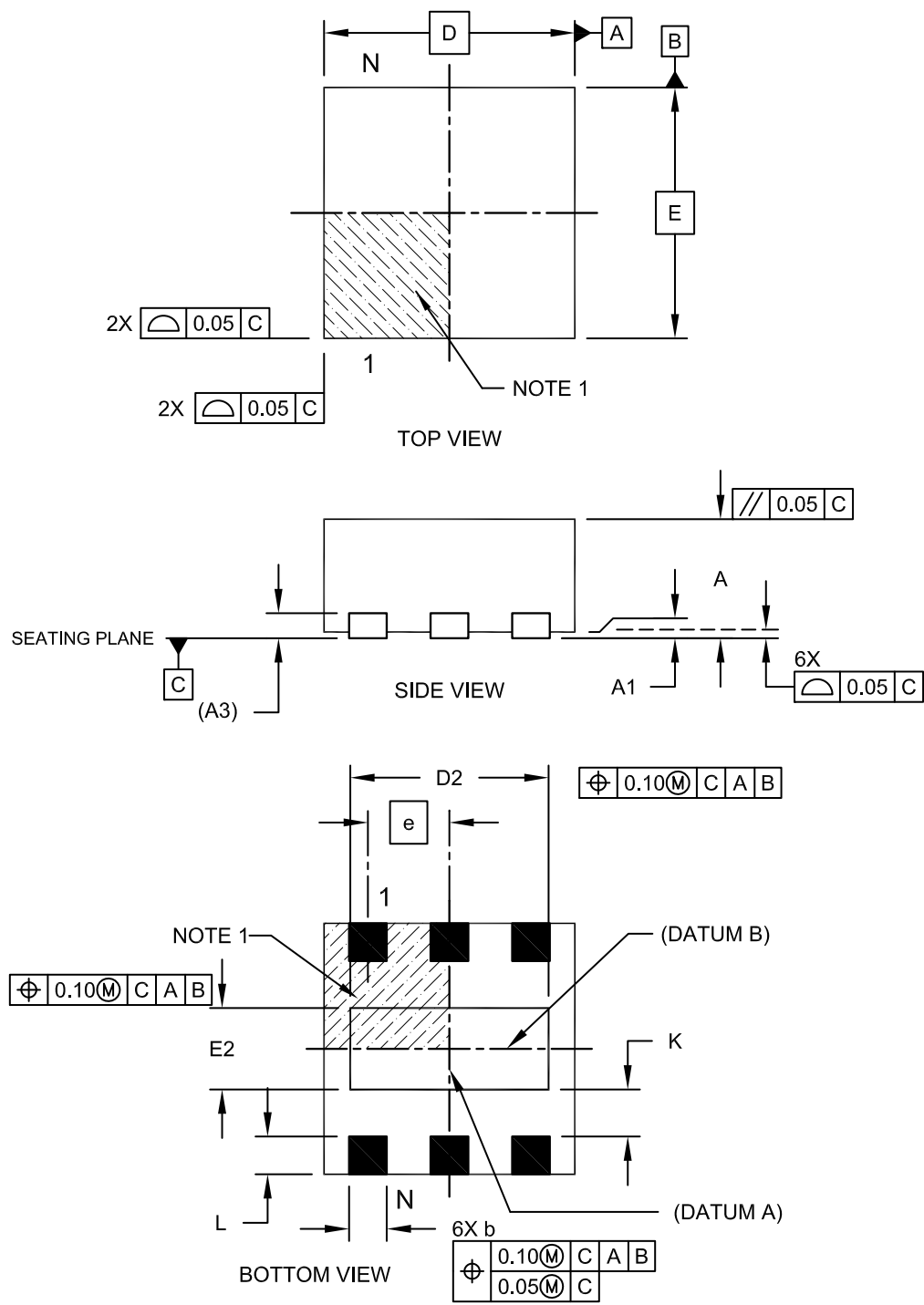

---



---

## Package Outlines and Dimensions

---



---

### 6-Lead Plastic Dual Flat, No Lead Package (MA[Y]) - 2x2x0.9mm Body [DFN]

**Note:** For the most current package drawings, please see the Microchip Packaging Specification located at <http://www.microchip.com/packaging>

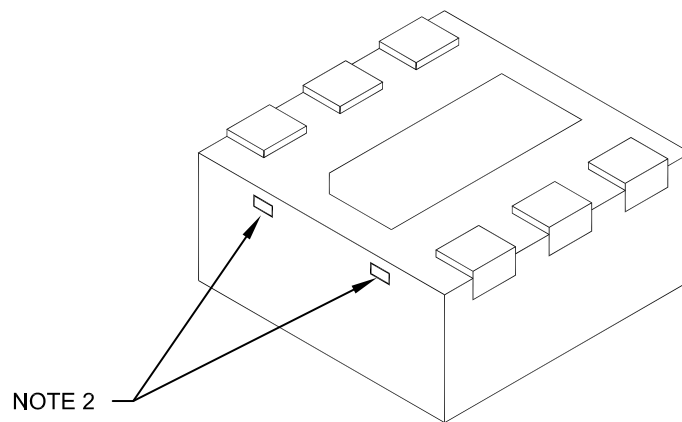

Dimension Limits	Units	MILLIMETERS		
		MIN	NOM	MAX
Number of Pins	N	6		
Pitch	e	0.65 BSC		
Overall Height	A	0.80	0.85	0.90
Standoff	A1	0.00	0.02	0.05
Contact Thickness	A3	0.20 REF		
Overall Length	D	2.00 BSC		
Overall Width	E	2.00 BSC		
Exposed Pad Length	D2	1.50	1.60	1.70
Exposed Pad Width	E2	0.90	1.00	1.10
Contact Width	b	0.25	0.30	0.35
Contact Length	L	0.20	0.25	0.30
Contact-to-Exposed Pad	K	0.20	-	-

**Notes:**

1. Pin 1 visual index feature may vary, but must be located within the hatched area.
2. Package may have one or more exposed tie bars at ends.
3. Package is saw singulated.
4. Dimensioning and tolerancing per ASME Y14.5M.
  - BSC: Basic Dimension. Theoretically exact value shown without tolerances.
  - REF: Reference Dimension, usually without tolerance, for information purposes only.

**Footprint Outlines and Dimensions**

**6-Lead Plastic Dual Flat, No Lead Package (MA) - 2x2x0.9mm Body [DFN]**

**Note:** For the most current package drawings, please see the Microchip Packaging Specification located at <http://www.microchip.com/packaging>

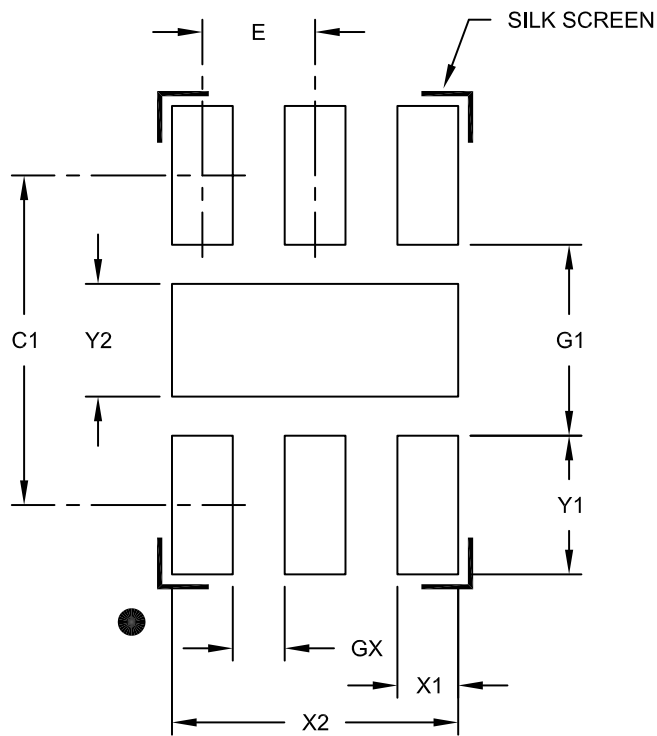

**RECOMMENDED LAND PATTERN**

Dimension Limits	Units	MILLIMETERS		
		MIN	NOM	MAX
Contact Pitch	E	0.65 BSC		
Optional Center Pad Width	Y2			1.00
Optional Center Pad Length	X2			1.70
Contact Pad Spacing	C1		2.10	
Contact Pad Width (X6)	X1			0.35
Contact Pad Length (X6)	Y1			0.65
Distance Between Pads	GX	0.20		
Distance Between Pads	G1	1.10		

**Notes:**

1. Dimensioning and tolerancing per ASME Y14.5M

BSC: Basic Dimension. Theoretically exact value shown without tolerances.

Microchip Technology Drawing No. C04-2120A

## Package Outlines and Dimensions

### 6-Lead Plastic Dual Flat, No Lead Package (ME) – 2x3x0.9 mm Body [DFN]

**Note:** For the most current package drawings, please see the Microchip Packaging Specification located at <http://www.microchip.com/packaging>

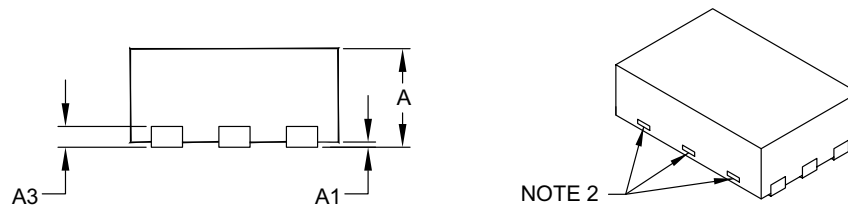
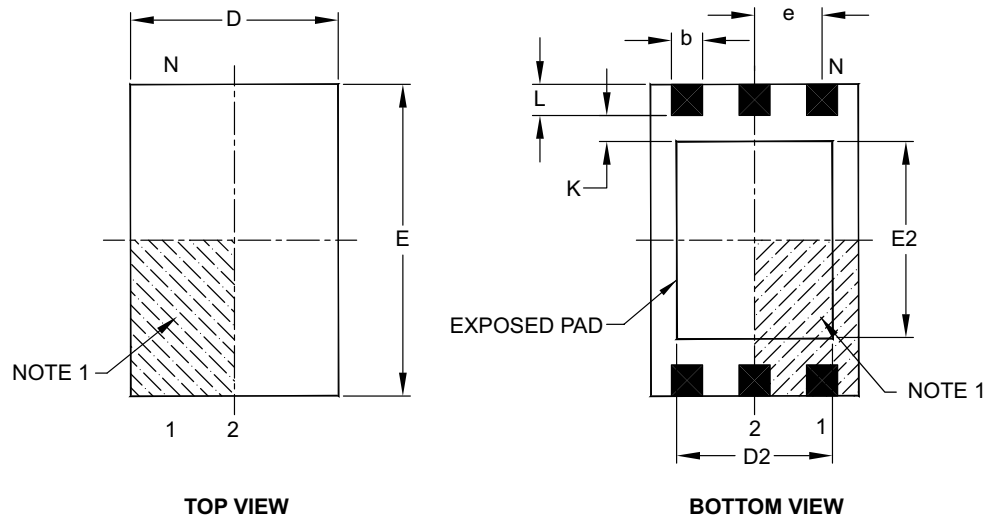

Dimension Limits	Units	MILLIMETERS		
		MIN	NOM	MAX
Number of Pins	N	6		
Pitch	e	0.65 BSC		
Overall Height	A	0.80	0.90	1.00
Standoff	A1	0.00	0.02	0.05
Contact Thickness	A3	0.20 REF		
Overall Length	D	2.00 BSC		
Overall Width	E	3.00 BSC		
Exposed Pad Length	D2	1.40	–	1.60
Exposed Pad Width	E2	1.80	–	2.00
Contact Width	b	0.25	0.30	0.35
Contact Length	L	0.20	0.30	0.40
Contact-to-Exposed Pad	K	0.20	–	–

**Notes:**

1. Pin 1 visual index feature may vary, but must be located within the hatched area.
2. Package may have one or more exposed tie bars at ends.
3. Package is saw singulated.
4. Dimensioning and tolerancing per ASME Y14.5M.

BSC: Basic Dimension. Theoretically exact value shown without tolerances.

REF: Reference Dimension, usually without tolerance, for information purposes only.

Microchip Technology Drawing C04-134A

## Package Outlines and Dimensions

### 6-Lead Plastic Dual Flat, No Lead Package (MH) – 3x3x0.9 mm Body [DFN]

**Note:** For the most current package drawings, please see the Microchip Packaging Specification located at <http://www.microchip.com/packaging>

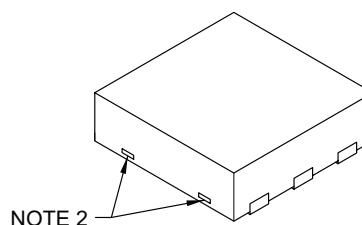
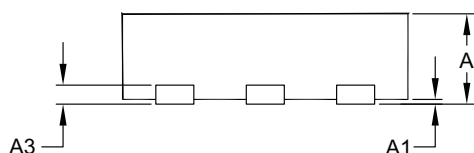
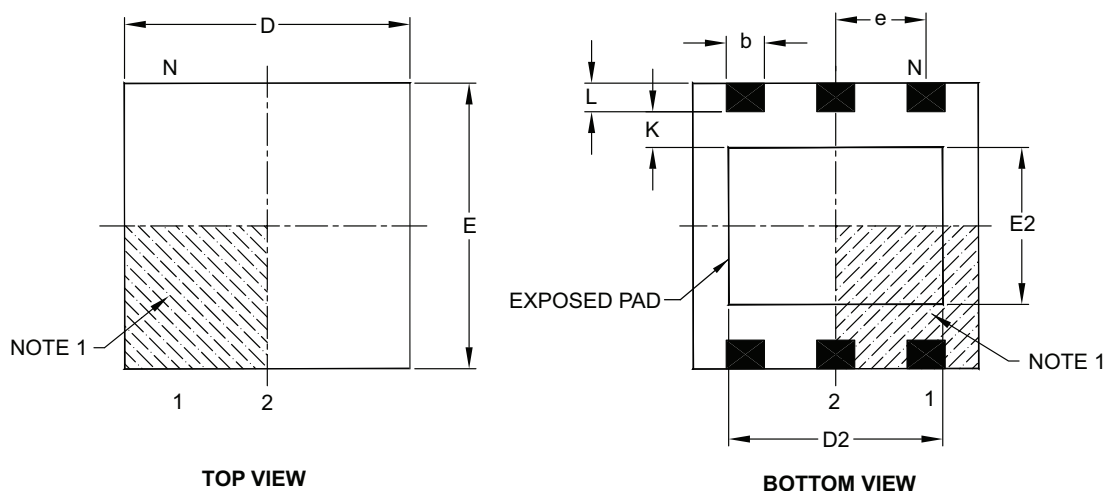

Dimension Limits	Units	MILLIMETERS		
		MIN	NOM	MAX
Number of Pins	N	6		
Pitch	e	0.95 BSC		
Overall Height	A	0.80	0.90	1.00
Standoff	A1	0.00	0.02	0.05
Contact Thickness	A3	0.20 REF		
Overall Length	D	3.00 BSC		
Overall Width	E	3.00 BSC		
Exposed Pad Length	D2	0.00	–	2.25
Exposed Pad Width	E2	0.00	–	1.65
Contact Width	b	0.30	0.40	0.45
Contact Length	L	0.20	0.30	0.45
Contact-to-Exposed Pad	K	0.20	–	–

**Notes:**

- Pin 1 visual index feature may vary, but must be located within the hatched area.
- Package may have one or more exposed tie bars at ends.
- Package is saw singulated.
- Dimensioning and tolerancing per ASME Y14.5M.  
 BSC: Basic Dimension. Theoretically exact value shown without tolerances.  
 REF: Reference Dimension, usually without tolerance, for information purposes only.

Microchip Technology Drawing C04-135A

---



---

## Package Outlines and Dimensions

---



---

### 8-Lead Plastic Dual Flat, No Lead Package (MC) – 2x3x0.9 mm Body [DFN]

**Note:** For the most current package drawings, please see the Microchip Packaging Specification located at <http://www.microchip.com/packaging>

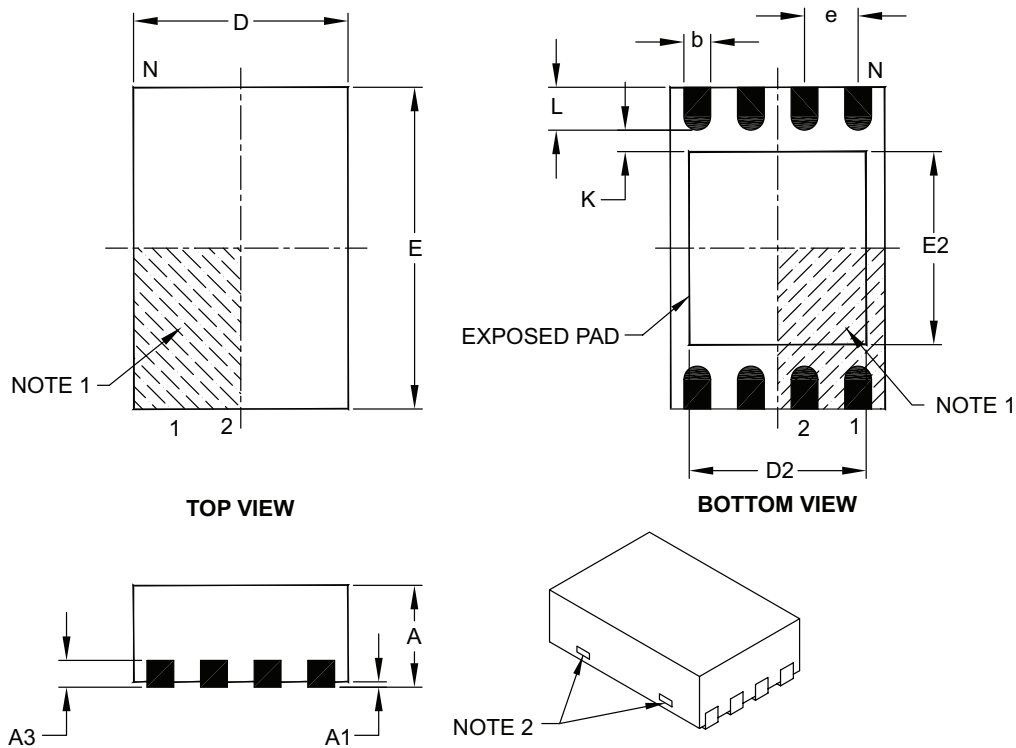

Dimension Limits	Units	MILLIMETERS		
		MIN	NOM	MAX
Number of Pins	N	8		
Pitch	e	0.50 BSC		
Overall Height	A	0.80	0.90	1.00
Standoff	A1	0.00	0.02	0.05
Contact Thickness	A3	0.20 REF		
Overall Length	D	2.00 BSC		
Overall Width	E	3.00 BSC		
Exposed Pad Length	D2	1.30	–	1.55
Exposed Pad Width	E2	1.50	–	1.75
Contact Width	b	0.20	0.25	0.30
Contact Length	L	0.30	0.40	0.50
Contact-to-Exposed Pad	K	0.20	–	–

**Notes:**

1. Pin 1 visual index feature may vary, but must be located within the hatched area.
2. Package may have one or more exposed tie bars at ends.
3. Package is saw singulated.
4. Dimensioning and tolerancing per ASME Y14.5M.

BSC: Basic Dimension. Theoretically exact value shown without tolerances.

REF: Reference Dimension, usually without tolerance, for information purposes only.

Microchip Technology Drawing C04-123C

**Footprint Outlines and Dimensions**

8-Lead Plastic Dual Flat, No Lead Package (MC) - 2x3x0.9mm Body [DFN]

**Note:** For the most current package drawings, please see the Microchip Packaging Specification located at <http://www.microchip.com/packaging>

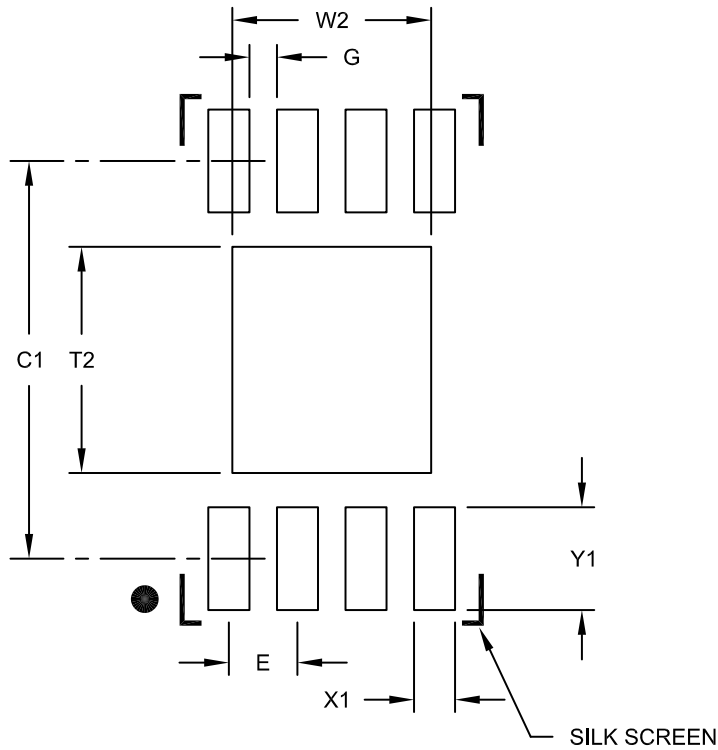

RECOMMENDED LAND PATTERN

Dimension Limits	Units	MILLIMETERS		
		MIN	NOM	MAX
Contact Pitch	E	0.50 BSC		
Optional Center Pad Width	W2			1.45
Optional Center Pad Length	T2			1.75
Contact Pad Spacing	C1		2.90	
Contact Pad Width (X8)	X1			0.30
Contact Pad Length (X8)	Y1			0.75
Distance Between Pads	G	0.20		

Notes:

1. Dimensioning and tolerancing per ASME Y14.5M

BSC: Basic Dimension. Theoretically exact value shown without tolerances.

Microchip Technology Drawing No. C04-2123B



**Package Outlines and Dimensions**

**8-Lead Plastic Dual Flat, No Lead Package (MF) - 3x3x0.9mm Body [DFN]**

**Note:** For the most current package drawings, please see the Microchip Packaging Specification located at <http://www.microchip.com/packaging>

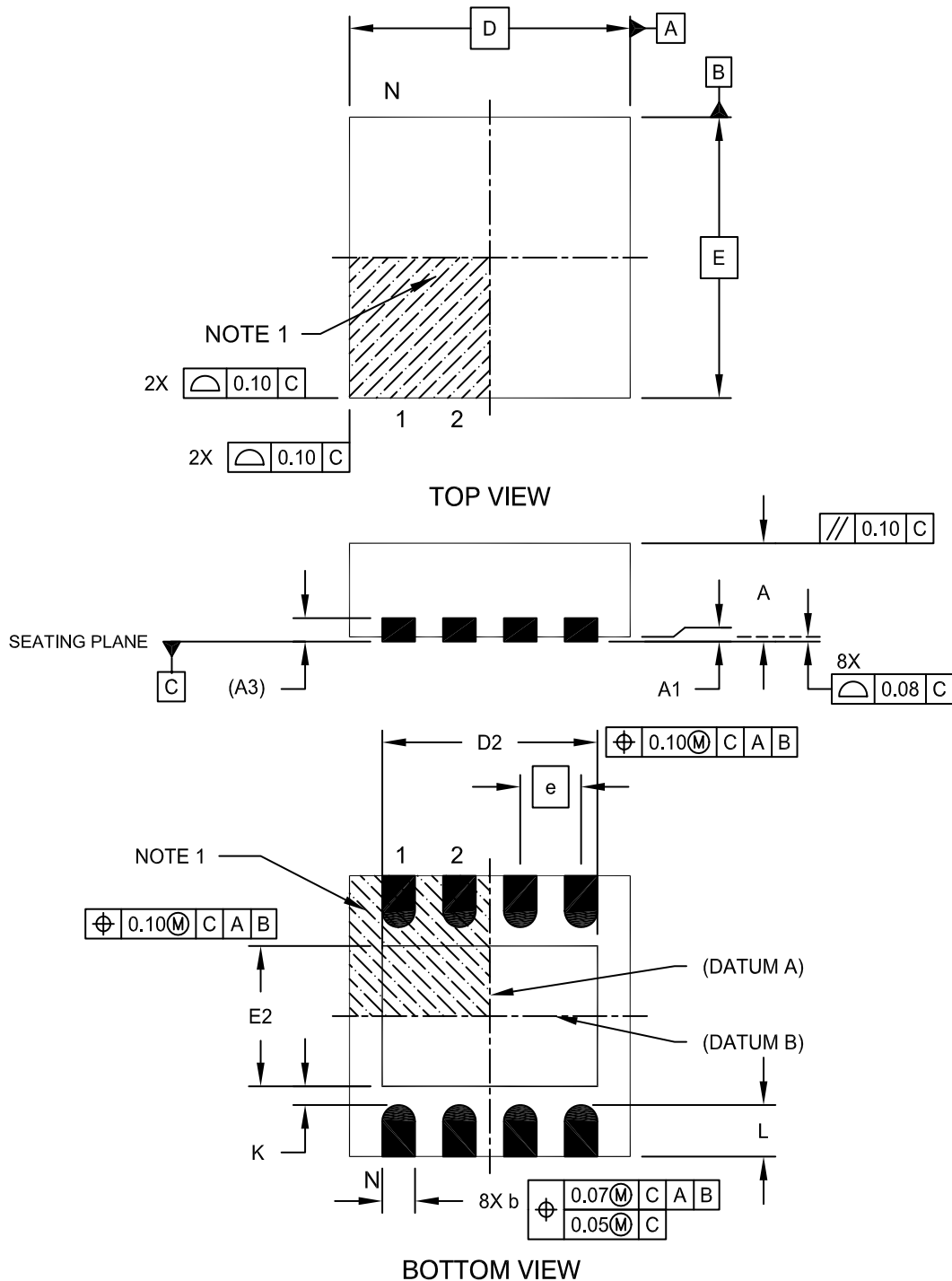

**Package Outlines and Dimensions**

**8-Lead Plastic Dual Flat, No Lead Package (MF) - 3x3x0.9mm Body [DFN]**

**Note:** For the most current package drawings, please see the Microchip Packaging Specification located at <http://www.microchip.com/packaging>

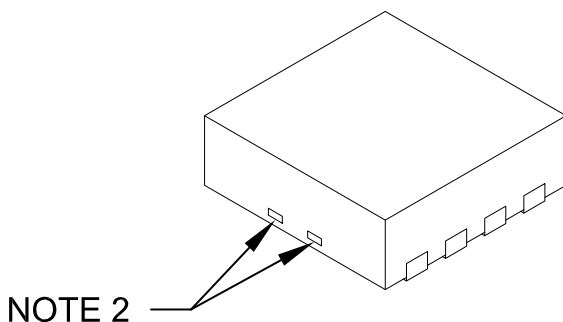

Dimension Limits	Units	MILLIMETERS		
		MIN	NOM	MAX
Number of Pins	N	8		
Pitch	e	0.65 BSC		
Overall Height	A	0.80	0.90	1.00
Standoff	A1	0.00	0.02	0.05
Contact Thickness	A3	0.20 REF		
Overall Length	D	3.00 BSC		
Exposed Pad Width	E2	1.34	-	1.60
Overall Width	E	3.00 BSC		
Exposed Pad Length	D2	1.60	-	2.40
Contact Width	b	0.25	0.30	0.35
Contact Length	L	0.20	0.30	0.55
Contact-to-Exposed Pad	K	0.20	-	-

**Notes:**

1. Pin 1 visual index feature may vary, but must be located within the hatched area.
2. Package may have one or more exposed tie bars at ends.
3. Package is saw singulated
4. Dimensioning and tolerancing per ASME Y14.5M

BSC: Basic Dimension. Theoretically exact value shown without tolerances.

REF: Reference Dimension, usually without tolerance, for information purposes only.

---



---

## Footprint Outlines and Dimensions

---



---

### 8-Lead Plastic Dual Flat, No Lead Package (MF) - 3x3x0.9mm Body [DFN]

**Note:** For the most current package drawings, please see the Microchip Packaging Specification located at <http://www.microchip.com/packaging>

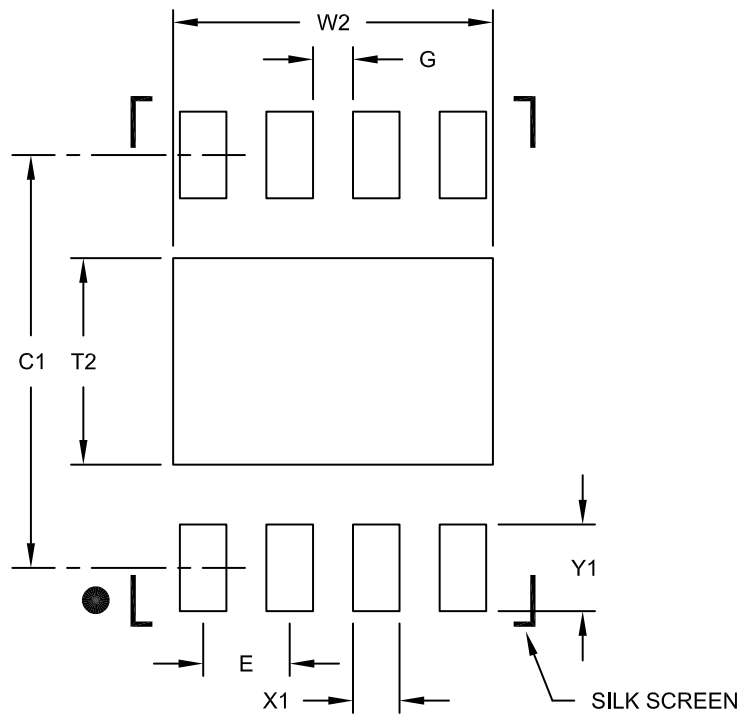

RECOMMENDED LAND PATTERN

Dimension Limits	Units	MILLIMETERS		
		MIN	NOM	MAX
Contact Pitch	E	0.65 BSC		
Optional Center Pad Width	W2			2.40
Optional Center Pad Length	T2			1.55
Contact Pad Spacing	C1		3.10	
Contact Pad Width (X8)	X1			0.35
Contact Pad Length (X8)	Y1			0.65
Distance Between Pads	G	0.30		

**Notes:**

1. Dimensioning and tolerancing per ASME Y14.5M

BSC: Basic Dimension. Theoretically exact value shown without tolerances.

Microchip Technology Drawing No. C04-2062B

**Package Outlines and Dimensions**

**8-Lead Plastic Dual Flat, No Lead Package (MD) – 4x4x0.9 mm Body [DFN]**

**Note:** For the most current package drawings, please see the Microchip Packaging Specification located at <http://www.microchip.com/packaging>

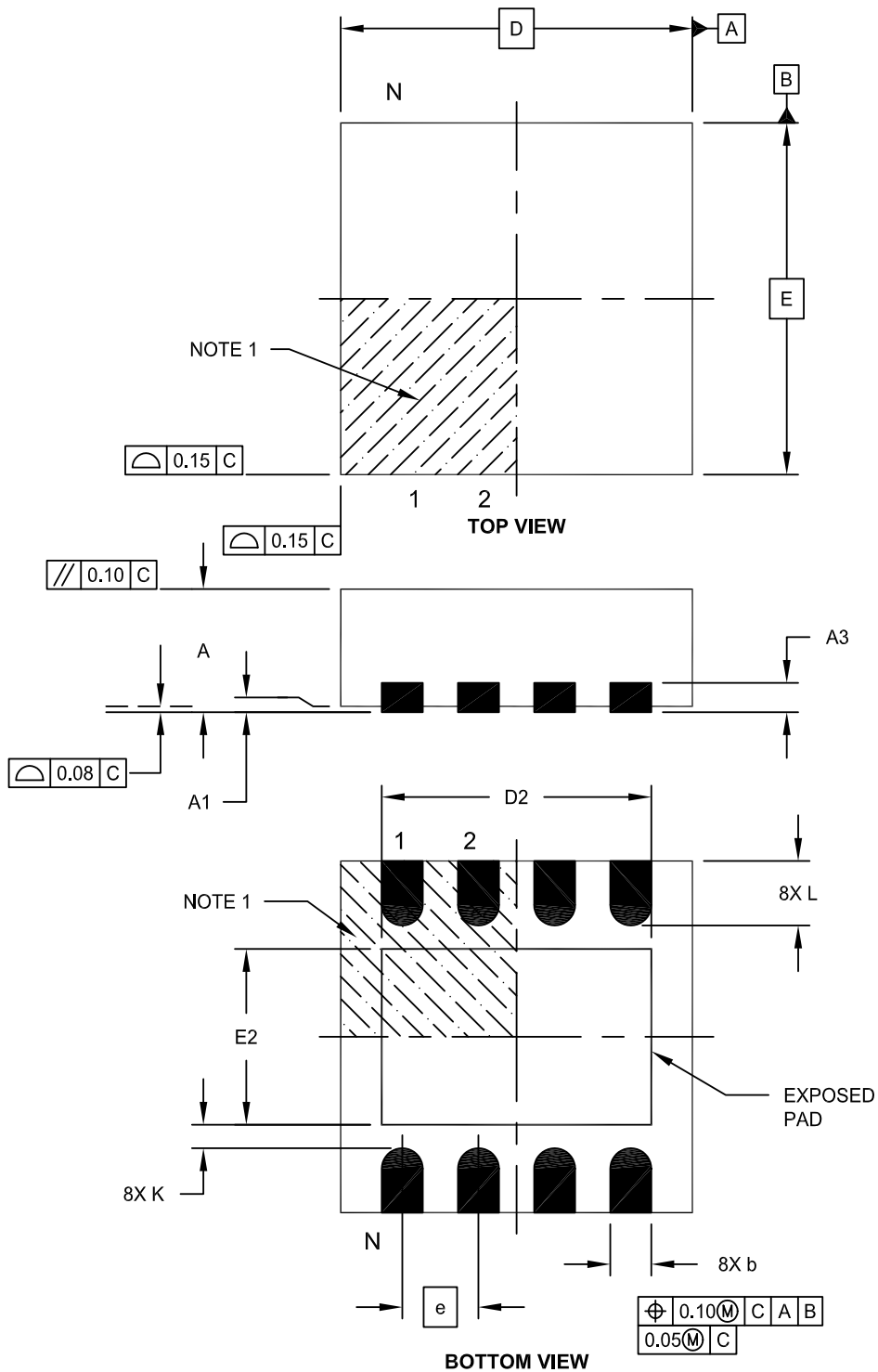

---



---

## Package Outlines and Dimensions

---



---

### 8-Lead Plastic Dual Flat, No Lead Package (MD) – 4x4x0.9 mm Body [DFN]

**Note:** For the most current package drawings, please see the Microchip Packaging Specification located at <http://www.microchip.com/packaging>

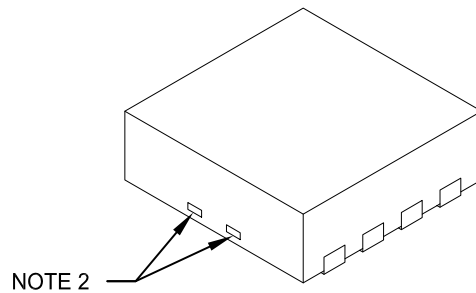

Dimension Limits	Units	MILLIMETERS		
		MIN	NOM	MAX
Number of Pins	N	8		
Pitch	e	0.80 BSC		
Overall Height	A	0.80	0.90	1.00
Standoff	A1	0.00	0.02	0.05
Contact Thickness	A3	0.20 REF		
Overall Length	D	4.00 BSC		
Exposed Pad Width	E2	2.60	2.70	2.80
Overall Width	E	4.00 BSC		
Exposed Pad Length	D2	3.40	3.50	3.60
Contact Width	b	0.25	0.30	0.35
Contact Length	L	0.30	0.40	0.50
Contact-to-Exposed Pad	K	0.20	-	-

**Notes:**

1. Pin 1 visual index feature may vary, but must be located within the hatched area.
2. Package may have one or more exposed tie bars at ends.
3. Package is saw singulated
4. Dimensioning and tolerancing per ASME Y14.5M
  - BSC: Basic Dimension. Theoretically exact value shown without tolerances.
  - REF: Reference Dimension, usually without tolerance, for information purposes only.

**Footprint Outlines and Dimensions**

8-Lead Plastic Dual Flat, No Lead Package (MD) - 4x4x0.9 mm Body [DFN]

**Note:** For the most current package drawings, please see the Microchip Packaging Specification located at <http://www.microchip.com/packaging>

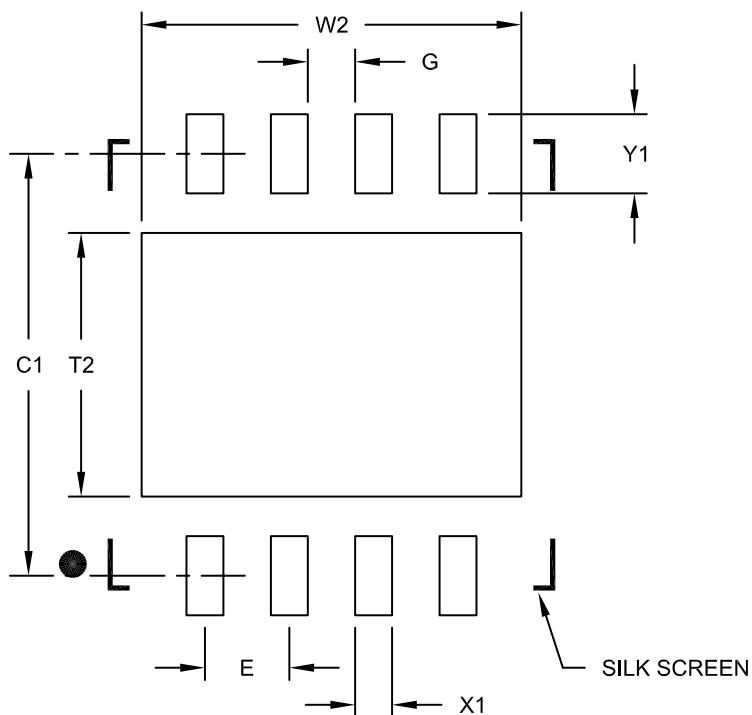

RECOMMENDED LAND PATTERN

Units		MILLIMETERS		
Dimension Limits		MIN	NOM	MAX
Contact Pitch	E	0.80 BSC		
Optional Center Pad Width	W2			3.60
Optional Center Pad Length	T2			2.50
Contact Pad Spacing	C1		4.00	
Contact Pad Width (X8)	X1			0.35
Contact Pad Length (X8)	Y1			0.75
Distance Between Pads	G	0.45		

Notes:

1. Dimensioning and tolerancing per ASME Y14.5M

BSC: Basic Dimension. Theoretically exact value shown without tolerances.

Microchip Technology Drawing No. C04-2131C

**Package Outlines and Dimensions**

**10-Lead Plastic Dual Flat, No Lead Package (MF) - 3x3x0.9mm Body [DFN]**

**Note:** For the most current package drawings, please see the Microchip Packaging Specification located at <http://www.microchip.com/packaging>

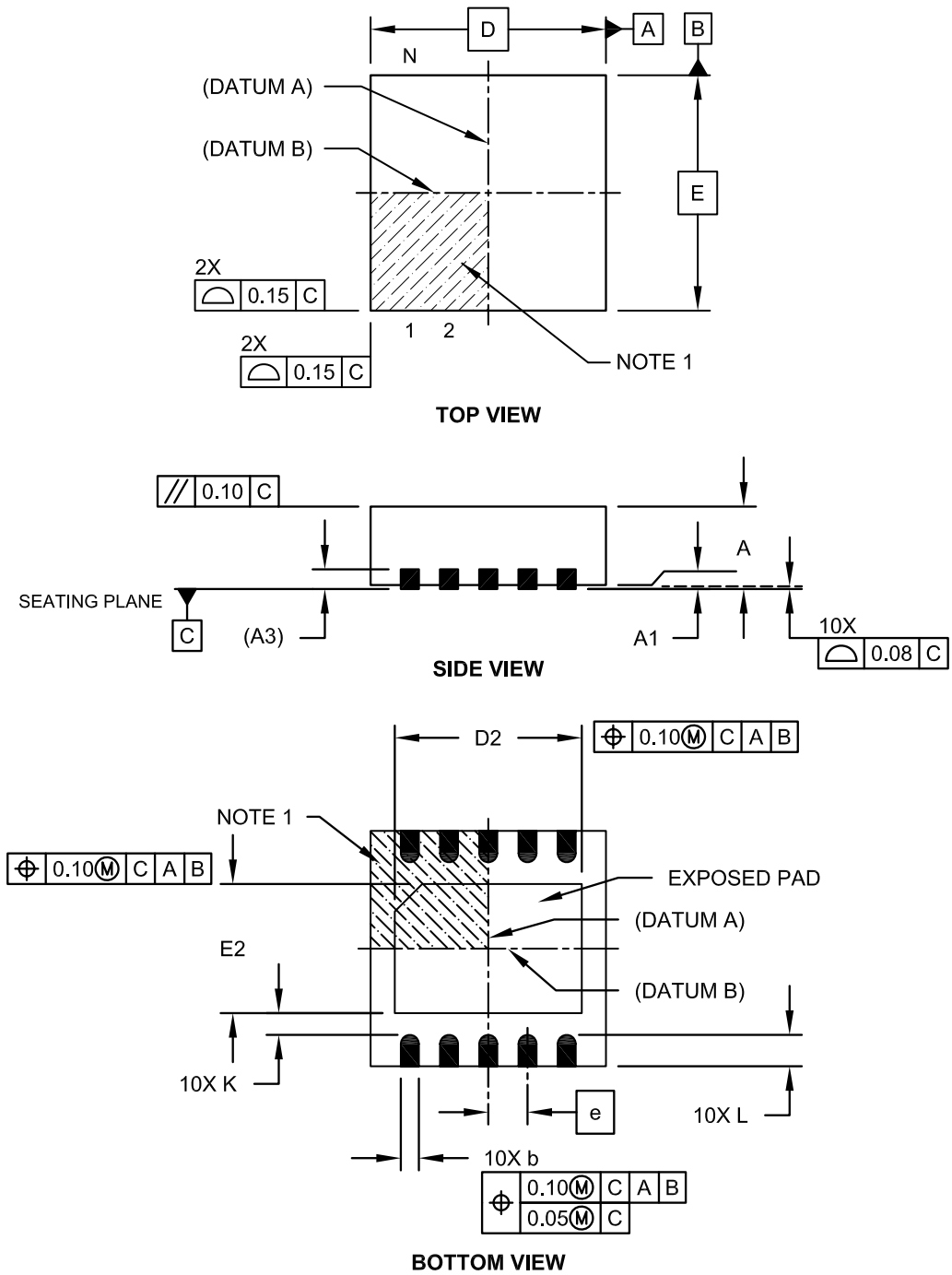

**Package Outlines and Dimensions**

**10-Lead Plastic Dual Flat, No Lead Package (MF) - 3x3x0.9mm Body [DFN]**

**Note:** For the most current package drawings, please see the Microchip Packaging Specification located at <http://www.microchip.com/packaging>

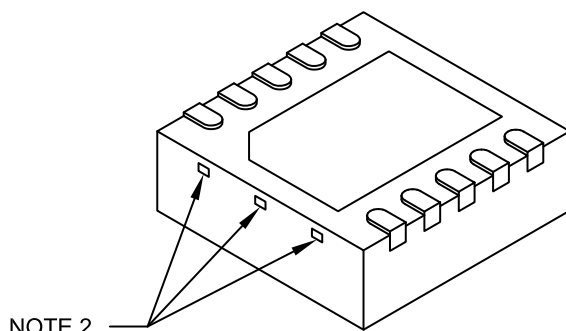

Dimension Limits	Units	MILLIMETERS		
		MIN	NOM	MAX
Number of Pins	N	10		
Pitch	e	0.50 BSC		
Overall Height	A	0.80	0.90	1.00
Standoff	A1	0.00	0.02	0.05
Contact Thickness	A3	0.20 REF		
Overall Length	D	3.00 BSC		
Exposed Pad Length	D2	2.15	2.35	2.45
Overall Width	E	3.00 BSC		
Exposed Pad Width	E2	1.40	1.50	1.75
Contact Width	b	0.18	0.25	0.30
Contact Length	L	0.30	0.40	0.50
Contact-to-Exposed Pad	K	0.20	-	-

**Notes:**

1. Pin 1 visual index feature may vary, but must be located within the hatched area.
2. Package may have one or more exposed tie bars at ends.
3. Package is saw singulated.
4. Dimensioning and tolerancing per ASME Y14.5M.  
 BSC: Basic Dimension. Theoretically exact value shown without tolerances.  
 REF: Reference Dimension, usually without tolerance, for information purposes only.



---



---

## Footprint Outlines and Dimensions

---



---

### 10-Lead Plastic Dual Flat, No Lead Package (MF) - 3x3x0.9mm Body [DFN]

**Note:** For the most current package drawings, please see the Microchip Packaging Specification located at <http://www.microchip.com/packaging>

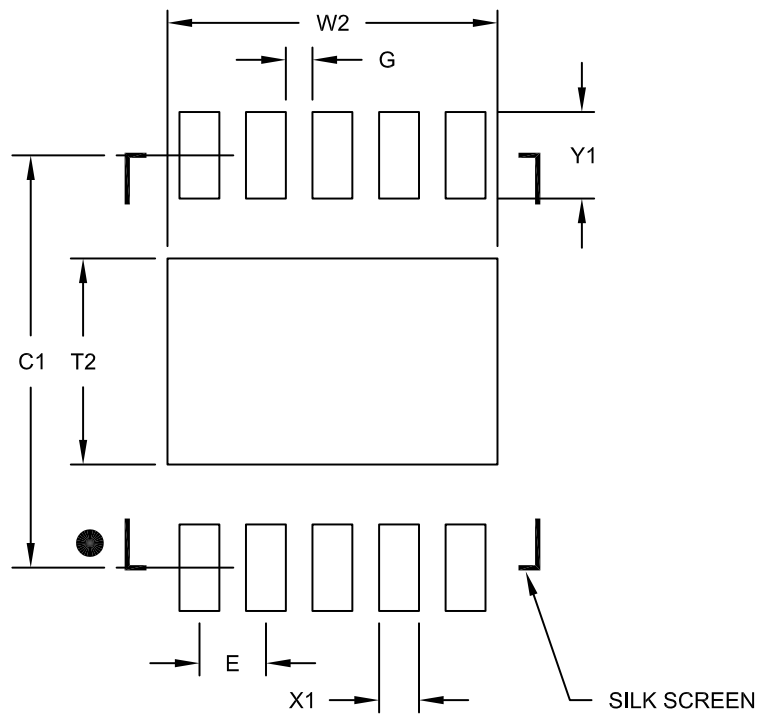

RECOMMENDED LAND PATTERN

Dimension Limits	Units	MILLIMETERS		
		MIN	NOM	MAX
Contact Pitch	E	0.50 BSC		
Optional Center Pad Width	W2			2.48
Optional Center Pad Length	T2			1.55
Contact Pad Spacing	C1		3.10	
Contact Pad Width (X10)	X1			0.30
Contact Pad Length (X10)	Y1			0.65
Distance Between Pads	G	0.20		

**Notes:**

1. Dimensioning and tolerancing per ASME Y14.5M

BSC: Basic Dimension. Theoretically exact value shown without tolerances.

Microchip Technology Drawing No. C04-2063B



**MICROCHIP**

---

---

**Package Outlines and Dimensions**

---

---

NOTES:

---

---

**Package Outlines and Dimensions**

---

---

**DFN-S**

**Package Outlines and Dimensions**

**8-Lead Plastic Dual Flat, No Lead Package (MF) – 6x5 mm Body [DFN-S]  
PUNCH SINGULATED**

**Note:** For the most current package drawings, please see the Microchip Packaging Specification located at <http://www.microchip.com/packaging>

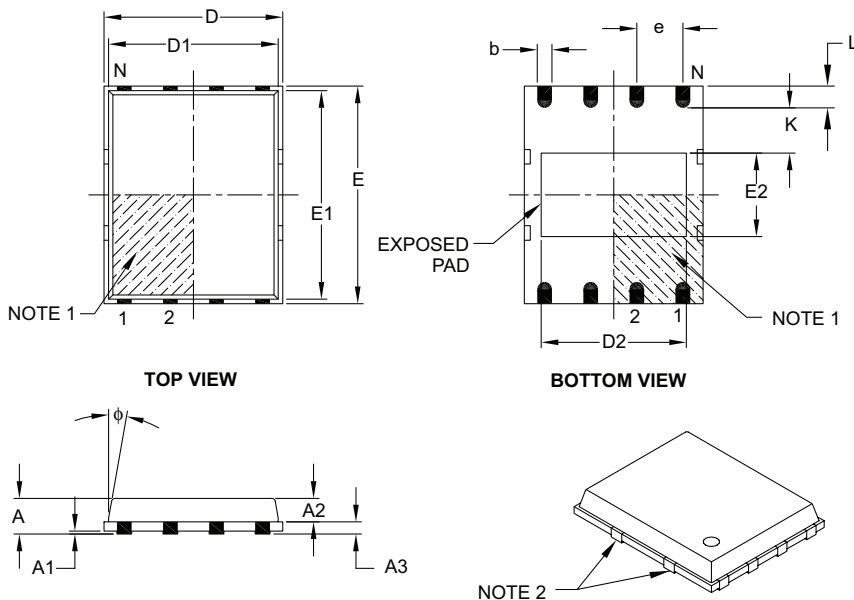

Dimension Limits	Units	MILLIMETERS		
		MIN	NOM	MAX
Number of Pins	N	8		
Pitch	e	1.27 BSC		
Overall Height	A	–	0.85	1.00
Molded Package Thickness	A2	–	0.65	0.80
Standoff	A1	0.00	0.01	0.05
Base Thickness	A3	0.20 REF		
Overall Length	D	4.92 BSC		
Molded Package Length	D1	4.67 BSC		
Exposed Pad Length	D2	3.85	4.00	4.15
Overall Width	E	5.99 BSC		
Molded Package Width	E1	5.74 BSC		
Exposed Pad Width	E2	2.16	2.31	2.46
Contact Width	b	0.35	0.40	0.47
Contact Length	L	0.50	0.60	0.75
Contact-to-Exposed Pad	K	0.20	–	–
Model Draft Angle Top	$\phi$	–	–	12°

**Notes:**

1. Pin 1 visual index feature may vary, but must be located within the hatched area.
2. Package may have one or more exposed tie bars at ends.
3. Dimensioning and tolerancing per ASME Y14.5M.

BSC: Basic Dimension. Theoretically exact value shown without tolerances.

REF: Reference Dimension, usually without tolerance, for information purposes only.

---



---

## Package Outlines and Dimensions

---



---

### 8-Lead Plastic Dual Flat, No Lead Package (MF) – 6x5 mm Body [DFN-S]

**Note:** For the most current package drawings, please see the Microchip Packaging Specification located at <http://www.microchip.com/packaging>

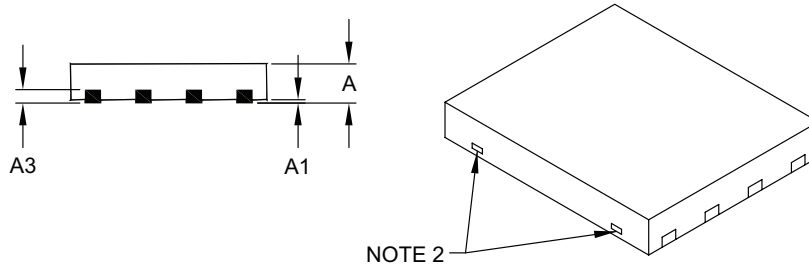
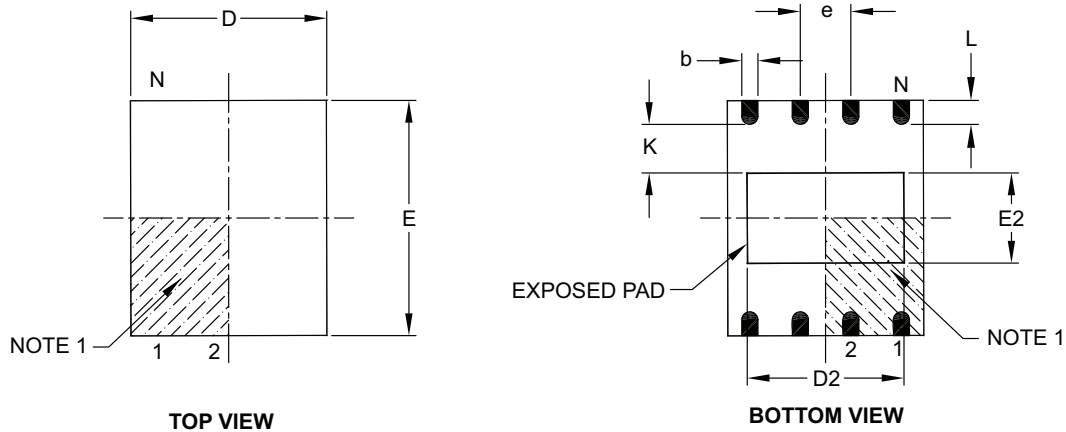

Dimension Limits	Units	MILLIMETERS		
		MIN	NOM	MAX
Number of Pins	N	8		
Pitch	e	1.27 BSC		
Overall Height	A	0.80	0.85	1.00
Standoff	A1	0.00	0.01	0.05
Contact Thickness	A3	0.20 REF		
Overall Length	D	5.00 BSC		
Overall Width	E	6.00 BSC		
Exposed Pad Length	D2	3.90	4.00	4.10
Exposed Pad Width	E2	2.20	2.30	2.40
Contact Width	b	0.35	0.40	0.48
Contact Length	L	0.50	0.60	0.75
Contact-to-Exposed Pad	K	0.20	–	–

**Notes:**

1. Pin 1 visual index feature may vary, but must be located within the hatched area.
2. Package may have one or more exposed tie bars at ends.
3. Package is saw singulated.
4. Dimensioning and tolerancing per ASME Y14.5M.

BSC: Basic Dimension. Theoretically exact value shown without tolerances.

REF: Reference Dimension, usually without tolerance, for information purposes only.

Microchip Technology Drawing C04-122B

**Footprint Outlines and Dimensions**

8-Lead Plastic Dual Flat, No Lead Package (MF) - 6x5 mm Body [DFN-S]

**Note:** For the most current package drawings, please see the Microchip Packaging Specification located at <http://www.microchip.com/packageing>

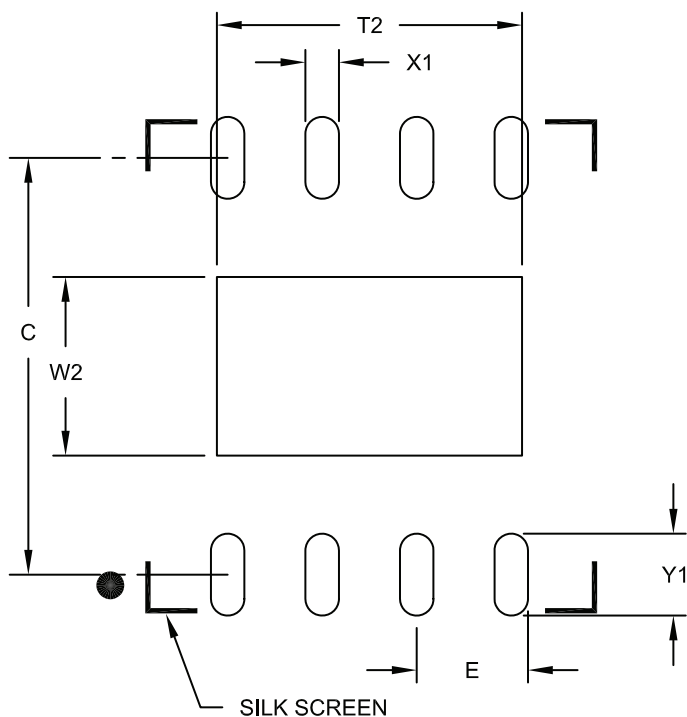

**RECOMMENDED LAND PATTERN**

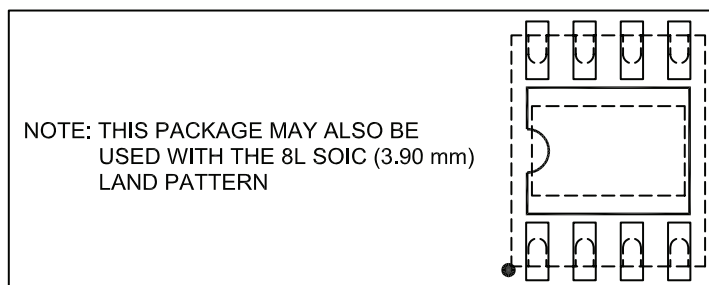

Dimension Limits	Units	MILLIMETERS		
		MIN	NOM	MAX
Contact Pitch	E	1.27 BSC		
Optional Center Pad Width	W2			2.40
Optional Center Pad Length	T2			4.10
Contact Pad Spacing	C		5.60	
Contact Pad Width (X8)	X1			0.45
Contact Pad Length (X8)	Y1			1.10

Notes:

1. Dimensioning and tolerancing per ASME Y14.5M

BSC: Basic Dimension. Theoretically exact value shown without tolerances.

Microchip Technology Drawing No. C04-2122A

---

---

**Package Outlines and Dimensions**

---

---

**PDFN**

**Package Outlines and Dimensions**

**8-Lead Power Dual Flatpack No Lead Package (MF) – 5x6x1.0 mm Body [PDFN]**

**Note:** For the most current package drawings, please see the Microchip Packaging Specification located at <http://www.microchip.com/packaging>

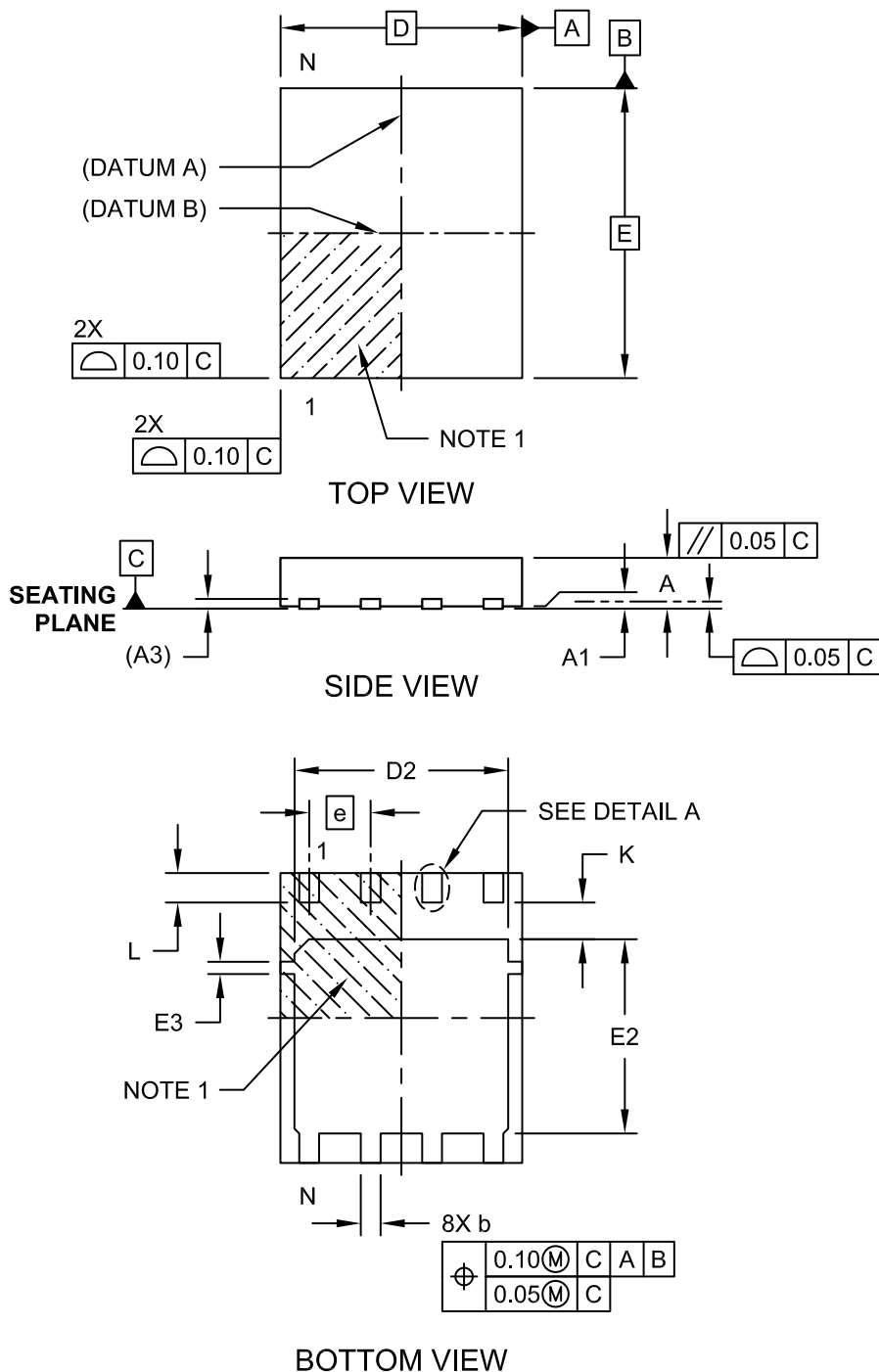



---



---

## Package Outlines and Dimensions

---



---

### 8-Lead Power Dual Flatpack No Lead Package (MF) – 5x6x1.0 mm Body [PDFN]

**Note:** For the most current package drawings, please see the Microchip Packaging Specification located at <http://www.microchip.com/packaging>

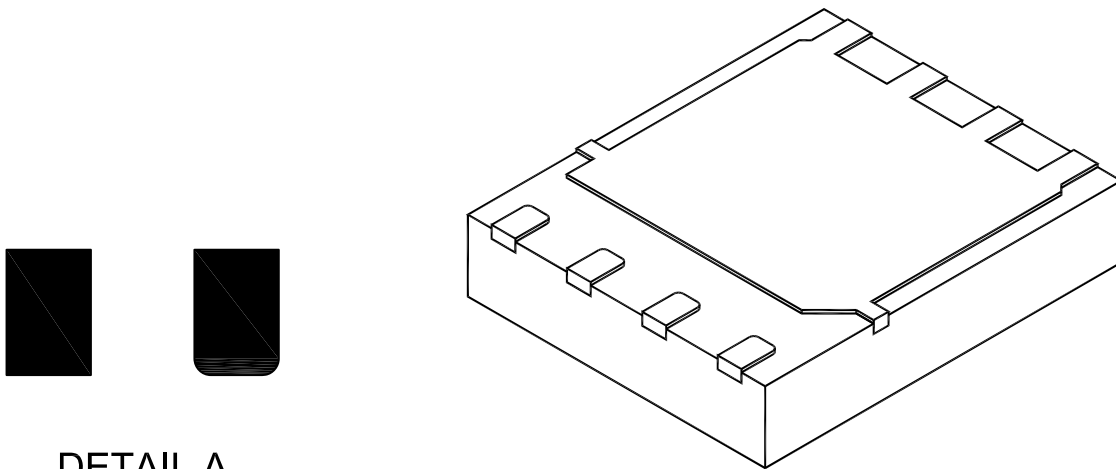

#### DETAIL A

ALTERNATE  
CONTACT  
SHAPES

Dimension	Units Limits	MILLIMETERS		
		MIN	NOM	MAX
Number of Pins	N	8		
Pitch	e	1.27 BSC		
Overall Height	A	0.80	1.00	1.03
Standoff	A1	0.00	-	0.05
Terminal Thickness	(A3)	0.20 REF		
Overall Length	D	5.00 BSC		
Overall Width	E	6.00 BSC		
Exposed Pad length	D2	4.27	4.42	4.52
Exposed Pad Width	E2	3.87	4.02	4.12
Tab Width	E3	0.20	0.25	0.30
Terminal Width	b	0.36	0.41	0.46
Terminal Length	L	0.51	0.61	0.71
Terminal to Exposed Pad	K	0.71	0.76	0.81

**Notes:**

1. Pin 1 visual index feature may vary, but must be located within the hatched area.
2. Package is saw singulated.
3. Package dimension does not include mold flash, protrusions, burrs or metal smearing.
4. Dimensioning and tolerancing per ASME Y14.5M.
  - BSC: Basic Dimension. Theoretically exact value shown without tolerances.
  - REF: Reference Dimension, usually without tolerance, for information purposes only.

**Footprint Outlines and Dimensions**

8-Lead Power Dual Flatpack No Lead Package (MF) – 5x6x1.0 mm Body [PDFN]

**Note:** For the most current package drawings, please see the Microchip Packaging Specification located at <http://www.microchip.com/packaging>

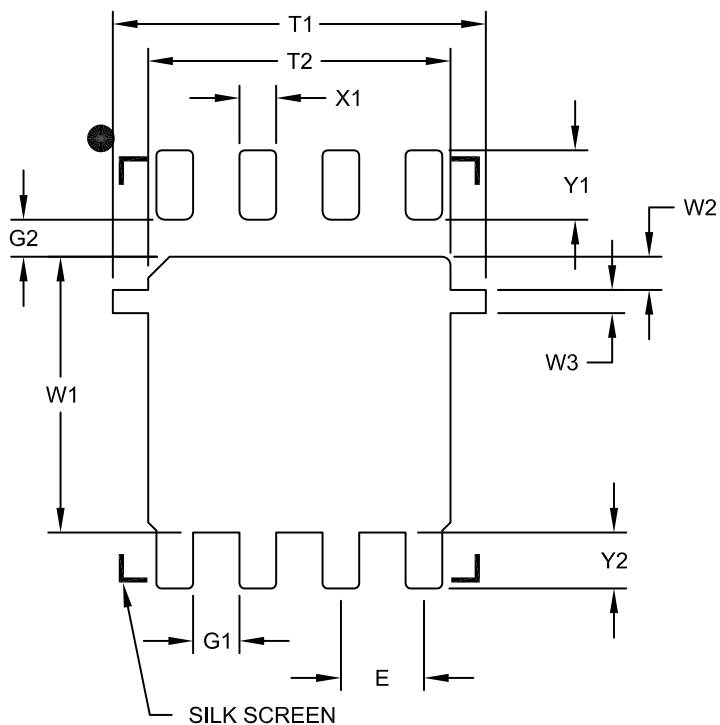

**RECOMMENDED LAND PATTERN**

Dimension Limits	Units	MILLIMETERS		
		MIN	NOM	MAX
Contact Pitch	E	1.27 BSC		
Center Pad Width	W1			4.22
Pad Edge to Tab	W2		0.51	
Tab Width	W3		0.35	
Center Pad Length With Tabs	T1			5.70
Center Pad Length	T2			4.62
Distance Between Terminals	G1	0.71		
Terminal To Center Pad (X4)	G2	0.57		
Terminal Pad Width (X8)	X1			0.56
Terminal Pad Length (X4)	Y1			1.06
Terminal Pad Length (X8)	Y2			0.86

Notes:

1. Dimensioning and tolerancing per ASME Y14.5M

BSC: Basic Dimension. Theoretically exact value shown without tolerances.

Microchip Technology Drawing No. C04-2188A

**Package Outlines and Dimensions**

**8-Lead Power Dual Flatpack No Lead Package (LC) – 3.3x3.3x1.0 mm Body [PDFN]**

**Note:** For the most current package drawings, please see the Microchip Packaging Specification located at <http://www.microchip.com/packaging>

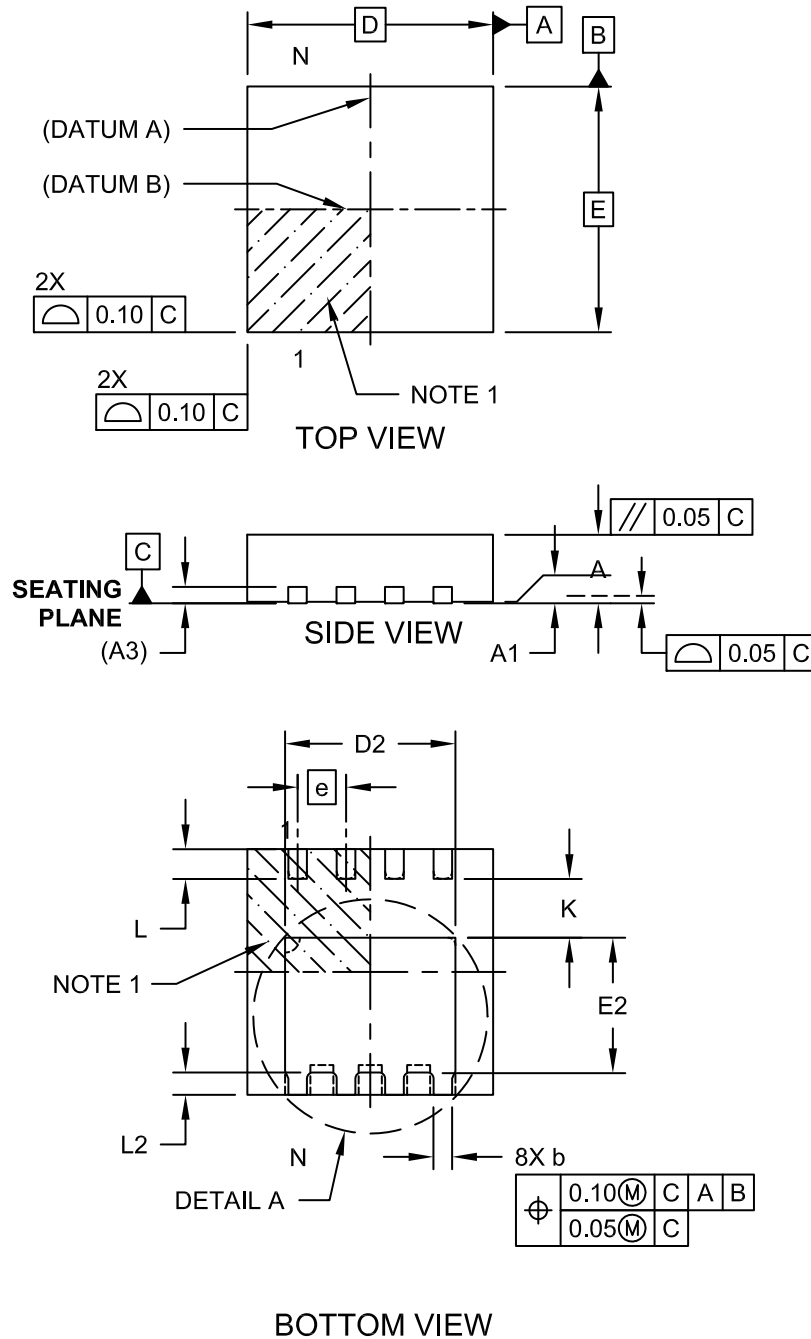

**Package Outlines and Dimensions**

**8-Lead Power Dual Flatpack No Lead Package (LC) – 3.3x3.3x1.0 mm Body [PDFN]**

**Note:** For the most current package drawings, please see the Microchip Packaging Specification located at <http://www.microchip.com/packaging>

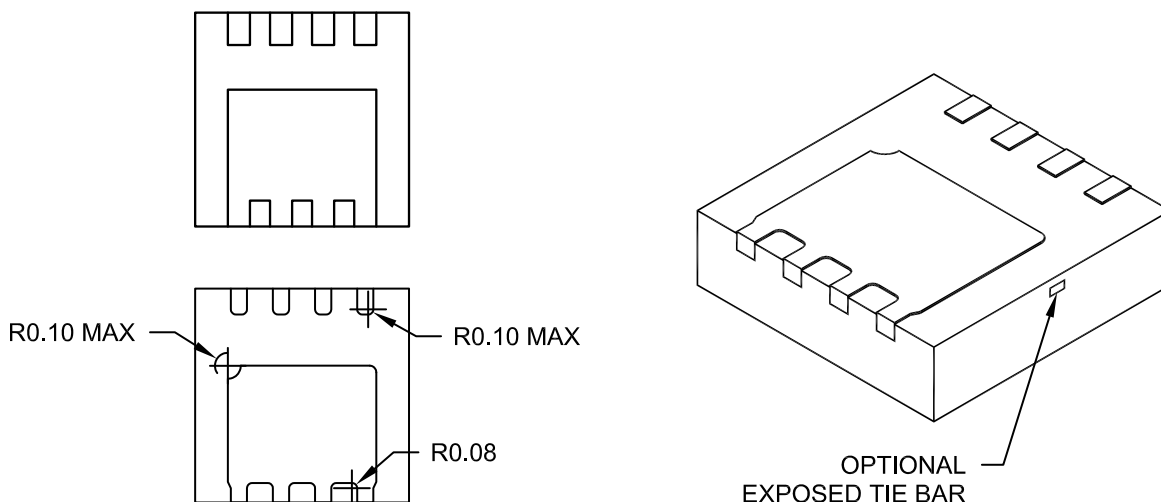

**DETAIL A**  
ALTERNATE EXPOSED PAD CONFIGURATIONS

Dimension	Units	MILLIMETERS		
		MIN	NOM	MAX
Number of Pins	N	8		
Pitch	e	0.65 BSC		
Overall Height	A	0.80	1.00	1.03
Standoff	A1	0.00	-	0.05
Terminal Thickness	(A3)	0.20 REF		
Overall Length	D	3.30 BSC		
Overall Width	E	3.30 BSC		
Exposed Pad length	D2	2.14	2.29	2.39
Exposed Pad Width	E2	1.66	1.81	1.91
Terminal Width	b	0.25	0.30	0.35
Terminal Length	L	0.30	0.40	0.50
Terminal Length	L2	0.30	-	0.40
Terminal to Exposed Pad	K	0.60	-	-

**Notes:**

- Pin 1 visual index feature may vary, but must be located within the hatched area.
- Package may have one or more exposed tie bars.
- Package is saw singulated.
- Package dimension does not include mold flash, protrusions, burrs or metal smearing.
- Dimensioning and tolerancing per ASME Y14.5M.  
BSC: Basic Dimension. Theoretically exact value shown without tolerances.  
REF: Reference Dimension, usually without tolerance, for information purposes only.

---



---

## Footprint Outlines and Dimensions

---



---

### 8-Lead Power Dual Flatpack No Lead Package (LC) – 3.3x3.3x1.0 mm Body [PDFN]

**Note:** For the most current package drawings, please see the Microchip Packaging Specification located at <http://www.microchip.com/packageing>

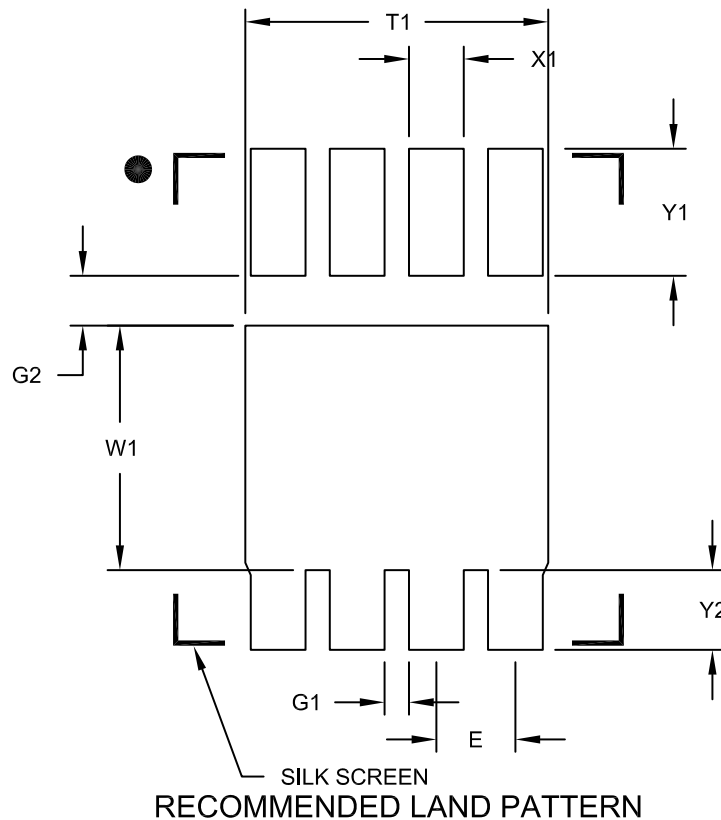

Dimension Limits	Units	MILLIMETERS		
		MIN	NOM	MAX
Contact Pitch	E	0.65 BSC		
Center Pad Width	W1			2.01
Center Pad Length	T1			2.49
Distance Between Terminals	G1	0.20		
Terminal Edge to Center Pad	G2	0.41		
Terminal Pad Width (X8)	X1			0.45
Terminal Pad Length (X4)	Y1			1.05
Terminal Pad Length (X8)	Y2			0.66

**Notes:**

1. Dimensioning and tolerancing per ASME Y14.5M

BSC: Basic Dimension. Theoretically exact value shown without tolerances.

Microchip Technology Drawing No. C04-2195A



**MICROCHIP**

---

---

**Package Outlines and Dimensions**

---

---

NOTES:

---

---

**Package Outlines and Dimensions**

---

---

**TDFN**

**Package Outlines and Dimensions**

**6-Lead Plastic Thin Dual Flat, No Lead Package (MY) – 2x2x0.8 mm Body [TDFN]**

**Note:** For the most current package drawings, please see the Microchip Packaging Specification located at <http://www.microchip.com/packaging>

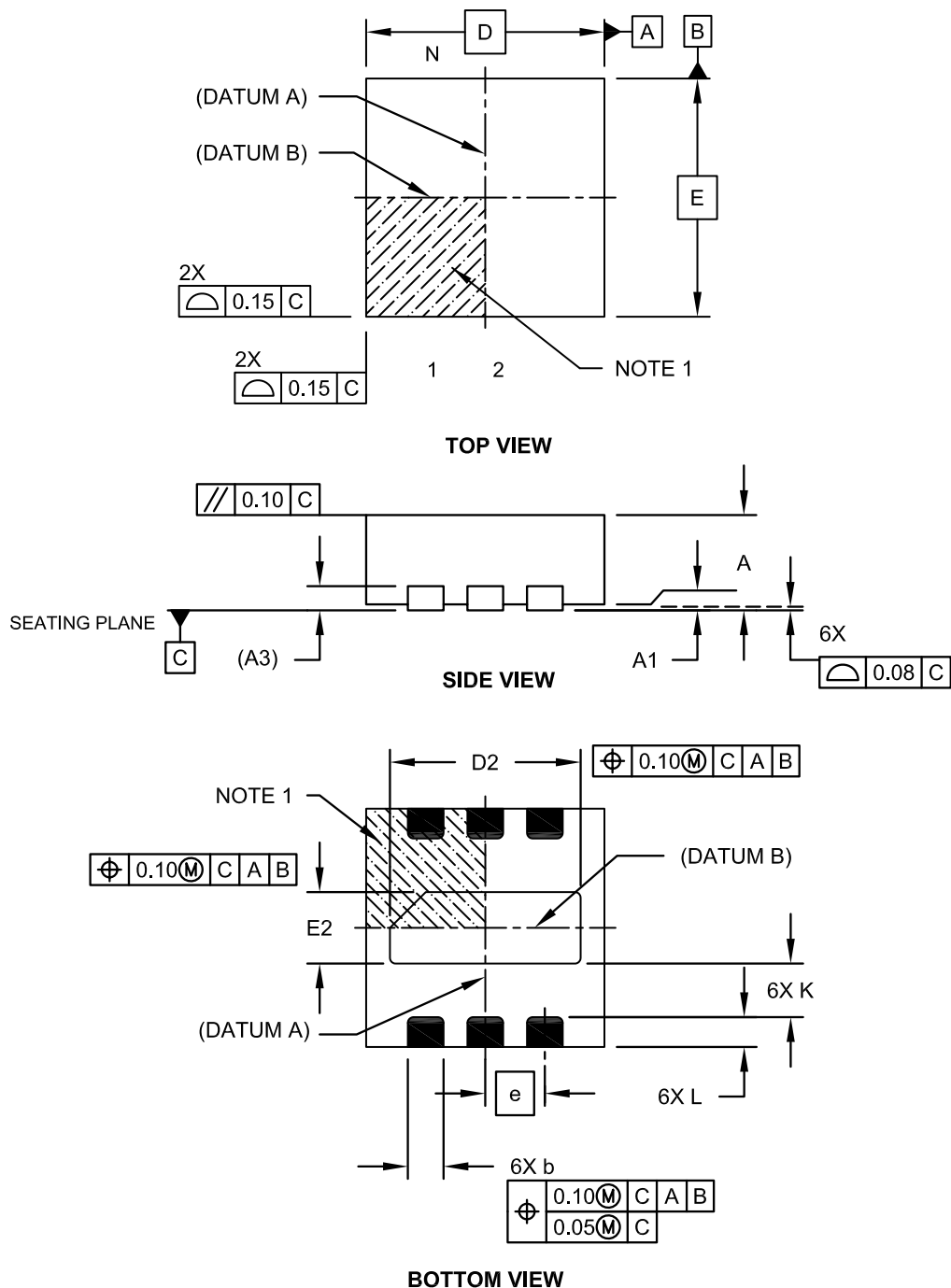



---



---

## Package Outlines and Dimensions

---



---

### 6-Lead Plastic Thin Dual Flat, No Lead Package (MY) – 2x2x0.8 mm Body [TDFN]

**Note:** For the most current package drawings, please see the Microchip Packaging Specification located at <http://www.microchip.com/packaging>

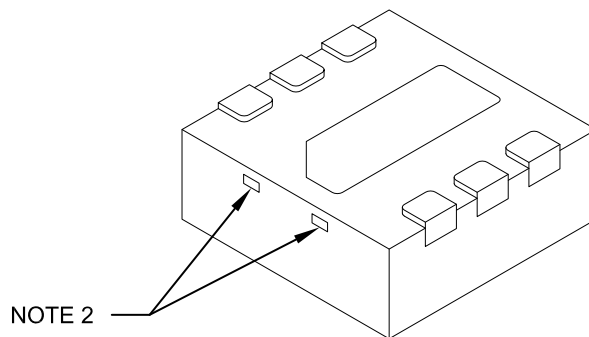

Dimension Limits	Units	MILLIMETERS		
		MIN	NOM	MAX
Number of Pins	N	6		
Pitch	e	0.50 BSC		
Overall Height	A	0.70	0.75	0.80
Standoff	A1	0.00	0.02	0.05
Contact Thickness	A3	0.20 REF		
Overall Width	E	2.00 BSC		
Exposed Pad Width	E2	0.55	0.60	0.65
Overall Length	D	2.00 BSC		
Exposed Pad Length	D2	1.55	1.60	1.65
Contact Width	b	0.25	0.30	0.35
Contact Length	L	0.20	0.25	0.30
Contact-to-Exposed Pad	K	0.20	-	-

**Notes:**

1. Pin 1 visual index feature may vary, but must be located within the hatched area.
2. Package may have one or more exposed tie bars at ends.
3. Package is saw singulated.
4. Dimensioning and tolerancing per ASME Y14.5M.

BSC: Basic Dimension. Theoretically exact value shown without tolerances.

REF: Reference Dimension, usually without tolerance, for information purposes only.

**Package Outlines and Dimensions**

**6-Lead Plastic Thin Dual Flat, No Lead Package (MYY) – 2x2x0.8 mm Body [TDFN]**

**Note:** For the most current package drawings, please see the Microchip Packaging Specification located at <http://www.microchip.com/packaging>

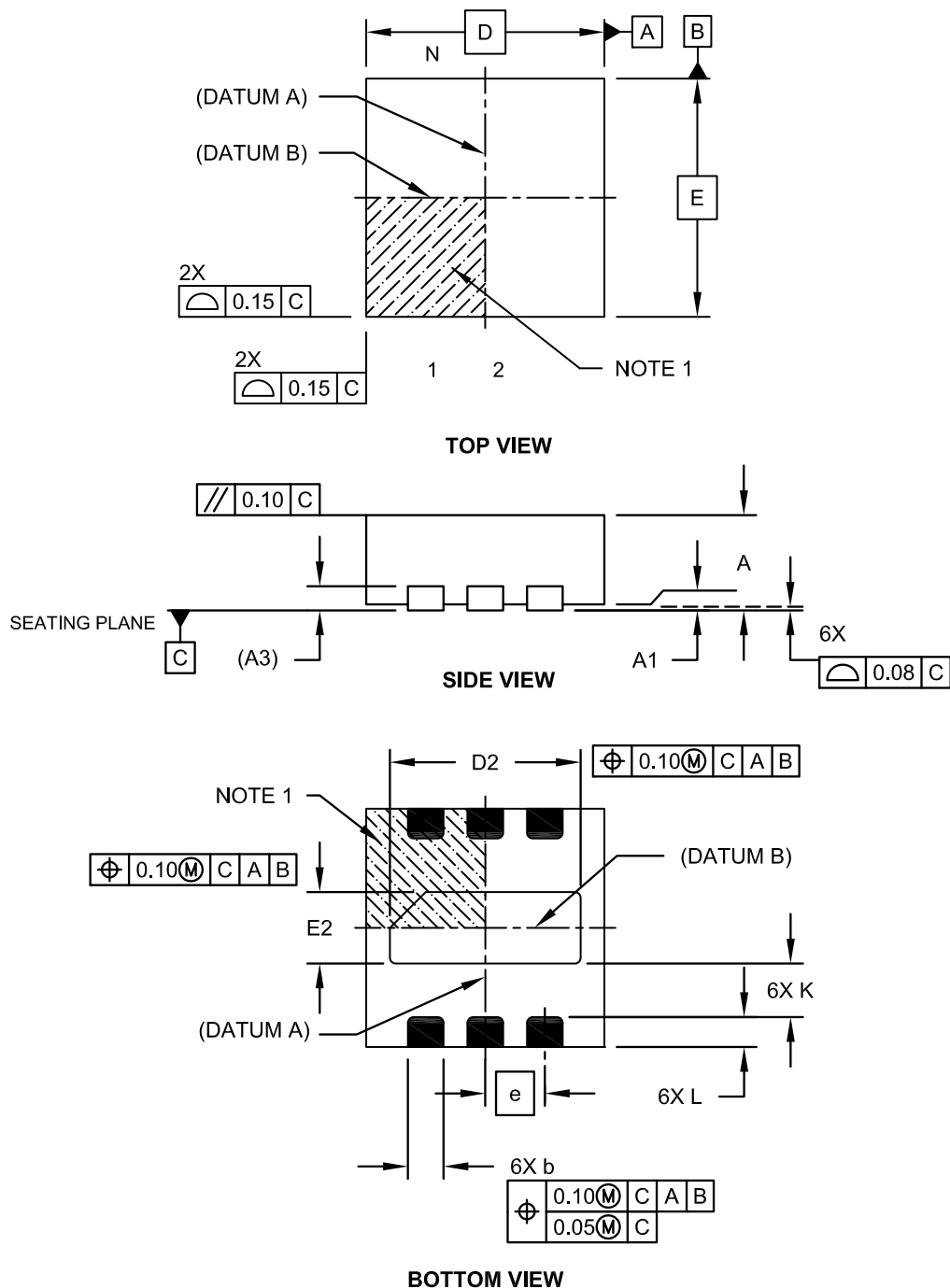

---



---

## Package Outlines and Dimensions

---



---

### 6-Lead Plastic Thin Dual Flat, No Lead Package (MYY) – 2x2x0.8 mm Body [TDFN]

**Note:** For the most current package drawings, please see the Microchip Packaging Specification located at <http://www.microchip.com/packaging>

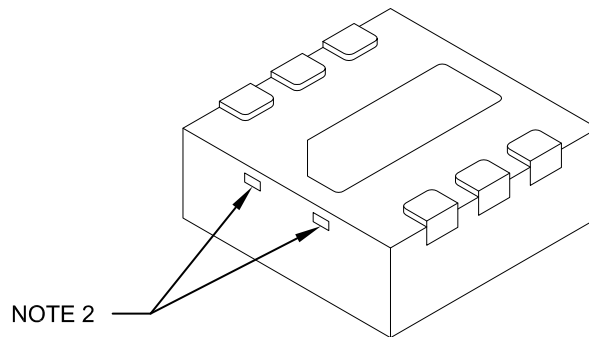

Dimension Limits	Units	MILLIMETERS		
		MIN	NOM	MAX
Number of Pins	N	6		
Pitch	e	0.50 BSC		
Overall Height	A	0.70	0.75	0.80
Standoff	A1	0.00	0.02	0.05
Contact Thickness	A3	0.20 REF		
Overall Width	E	2.00 BSC		
Exposed Pad Width	E2	0.55	0.60	0.65
Overall Length	D	2.00 BSC		
Exposed Pad Length	D2	1.55	1.60	1.65
Contact Width	b	0.25	0.30	0.35
Contact Length	L	0.20	0.25	0.30
Contact-to-Exposed Pad	K	0.20	-	-

**Notes:**

1. Pin 1 visual index feature may vary, but must be located within the hatched area.
2. Package may have one or more exposed tie bars at ends.
3. Package is saw singulated.
4. Dimensioning and tolerancing per ASME Y14.5M.

BSC: Basic Dimension. Theoretically exact value shown without tolerances.

REF: Reference Dimension, usually without tolerance, for information purposes only.

**Package Outlines and Dimensions**

**8-Lead Plastic Dual Flat, No Lead Package (MN) – 2x3x0.8 mm Body [TDFN]  
With 1.4x1.3 mm Exposed Pad (JEDEC Package type WDFN)**

**Note:** For the most current package drawings, please see the Microchip Packaging Specification located at <http://www.microchip.com/packaging>

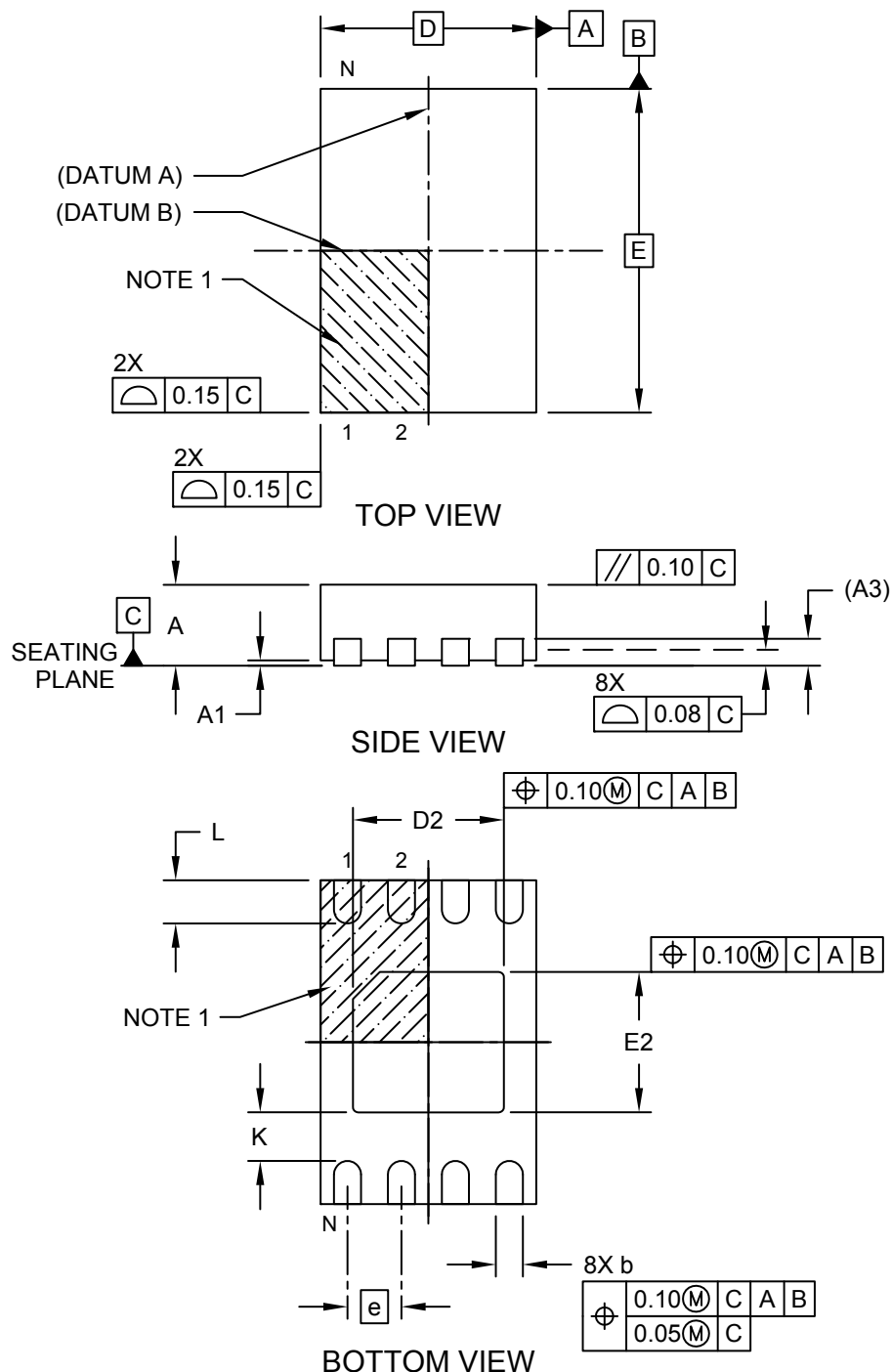

---



---

## Package Outlines and Dimensions

---



---

### 8-Lead Plastic Dual Flat, No Lead Package (MN) – 2x3x0.8 mm Body [TDFN] With 1.4x1.3 mm Exposed Pad (JEDEC Package type WDFN)

**Note:** For the most current package drawings, please see the Microchip Packaging Specification located at <http://www.microchip.com/packaging>

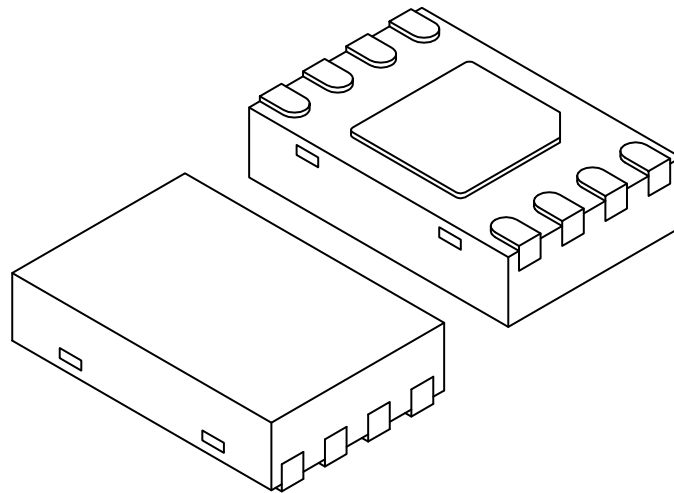

		Units	MILLIMETERS		
Dimension Limits			MIN	NOM	MAX
Number of Pins	N		8		
Pitch	e		0.50 BSC		
Overall Height	A	0.70	0.75	0.80	
Standoff	A1	0.00	0.02	0.05	
Contact Thickness	A3		0.20 REF		
Overall Length	D		2.00 BSC		
Overall Width	E		3.00 BSC		
Exposed Pad Length	D2	1.35	1.40	1.45	
Exposed Pad Width	E2	1.25	1.30	1.35	
Contact Width	b	0.20	0.25	0.30	
Contact Length	L	0.25	0.30	0.45	
Contact-to-Exposed Pad	K	0.20	-	-	

**Notes:**

1. Pin 1 visual index feature may vary, but must be located within the hatched area.
2. Package may have one or more exposed tie bars at ends.
3. Package is saw singulated
4. Dimensioning and tolerancing per ASME Y14.5M

BSC: Basic Dimension. Theoretically exact value shown without tolerances.

REF: Reference Dimension, usually without tolerance, for information purposes only.

**Footprint Outlines and Dimensions**

**8-Lead Plastic Dual Flat, No Lead Package (MN) – 2x3x0.8 mm Body [TDFN]  
With 1.4x1.3 mm Exposed Pad (JEDEC Package type WDFN)**

**Note:** For the most current package drawings, please see the Microchip Packaging Specification located at <http://www.microchip.com/packaging>

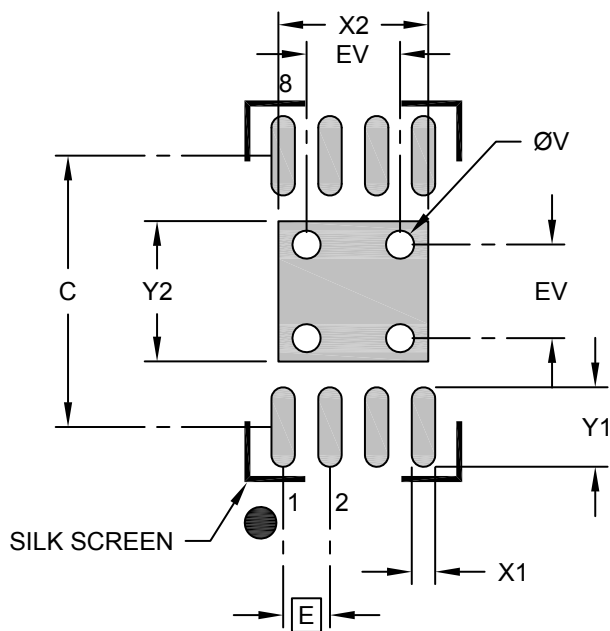

**RECOMMENDED LAND PATTERN**

Dimension Limits	Units	MILLIMETERS		
		MIN	NOM	MAX
Contact Pitch	E	0.50 BSC		
Optional Center Pad Width	X2			1.60
Optional Center Pad Length	Y2			1.50
Contact Pad Spacing	C		2.90	
Contact Pad Width (X8)	X1			0.25
Contact Pad Length (X8)	Y1			0.85
Thermal Via Diameter	V		0.30	
Thermal Via Pitch	EV		1.00	

**Notes:**

1. Dimensioning and tolerancing per ASME Y14.5M  
BSC: Basic Dimension. Theoretically exact value shown without tolerances.
2. For best soldering results, thermal vias, if used, should be filled or tented to avoid solder loss during reflow process

**Package Outlines and Dimensions**

**8-Lead Plastic Dual Flat, No Lead Package (MNY) – 2x3x0.8 mm Body [TDFN]  
With 1.4x1.3 mm Exposed Pad (JEDEC Package type WDFN)**

**Note:** For the most current package drawings, please see the Microchip Packaging Specification located at <http://www.microchip.com/packaging>

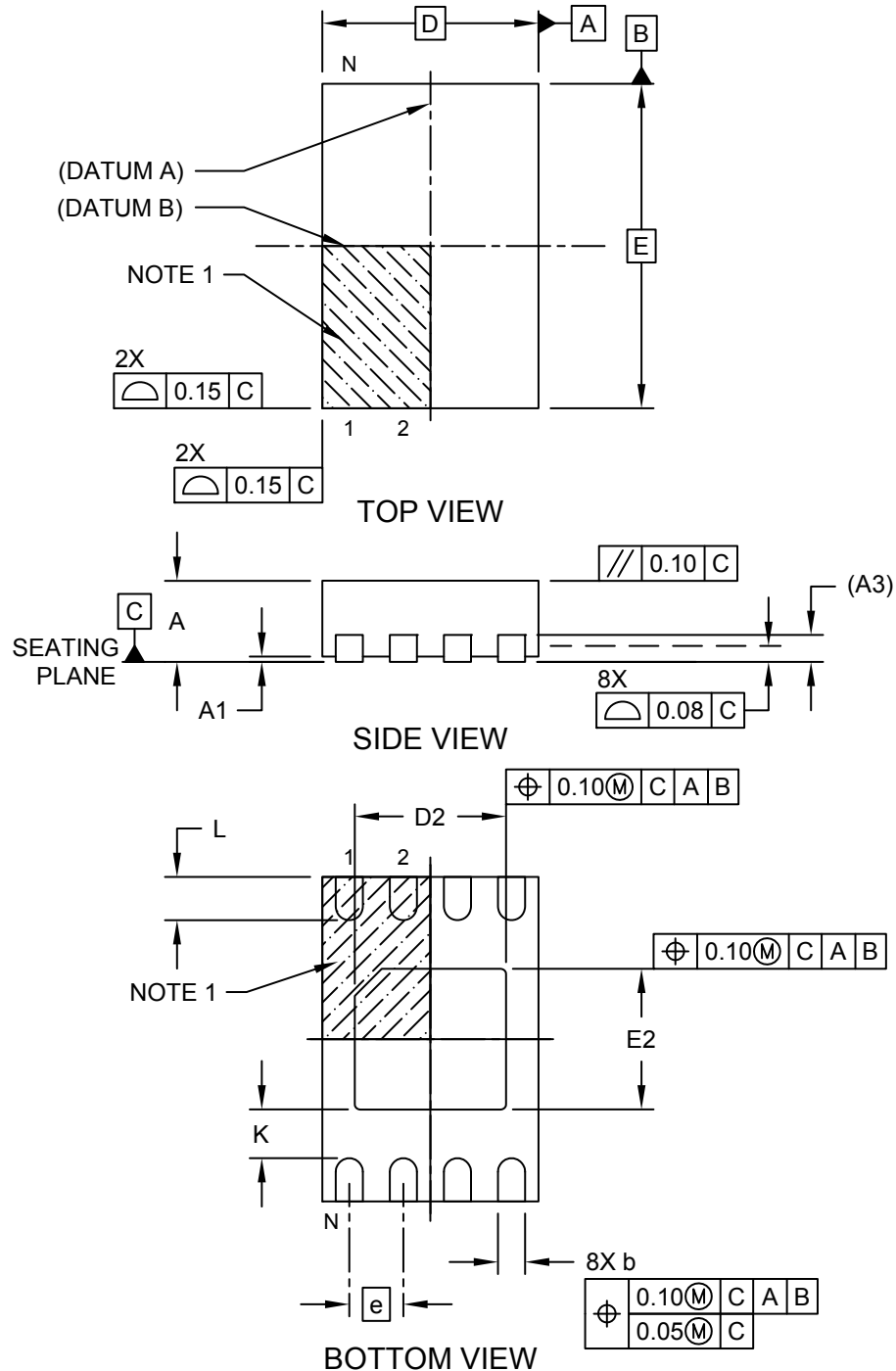

**Package Outlines and Dimensions**

**8-Lead Plastic Dual Flat, No Lead Package (MNY) – 2x3x0.8 mm Body [TDFN]  
With 1.4x1.3 mm Exposed Pad (JEDEC Package type WDFN)**

**Note:** For the most current package drawings, please see the Microchip Packaging Specification located at <http://www.microchip.com/packaging>

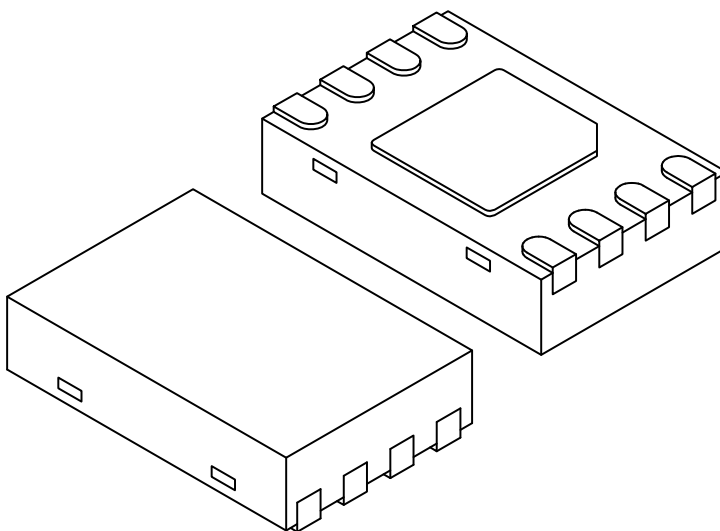

		MILLIMETERS		
Units		MIN	NOM	MAX
Dimension Limits				
Number of Pins	N	8		
Pitch	e	0.50 BSC		
Overall Height	A	0.70	0.75	0.80
Standoff	A1	0.00	0.02	0.05
Contact Thickness	A3	0.20 REF		
Overall Length	D	2.00 BSC		
Overall Width	E	3.00 BSC		
Exposed Pad Length	D2	1.35	1.40	1.45
Exposed Pad Width	E2	1.25	1.30	1.35
Contact Width	b	0.20	0.25	0.30
Contact Length	L	0.25	0.30	0.45
Contact-to-Exposed Pad	K	0.20	-	-

**Notes:**

1. Pin 1 visual index feature may vary, but must be located within the hatched area.
2. Package may have one or more exposed tie bars at ends.
3. Package is saw singulated
4. Dimensioning and tolerancing per ASME Y14.5M

BSC: Basic Dimension. Theoretically exact value shown without tolerances.

REF: Reference Dimension, usually without tolerance, for information purposes only.



---



---

## Footprint Outlines and Dimensions

---



---

### 8-Lead Plastic Dual Flat, No Lead Package (MNY) – 2x3x0.8 mm Body [TDFN] With 1.4x1.3 mm Exposed Pad (JEDEC Package type WDFN)

**Note:** For the most current package drawings, please see the Microchip Packaging Specification located at <http://www.microchip.com/packaging>

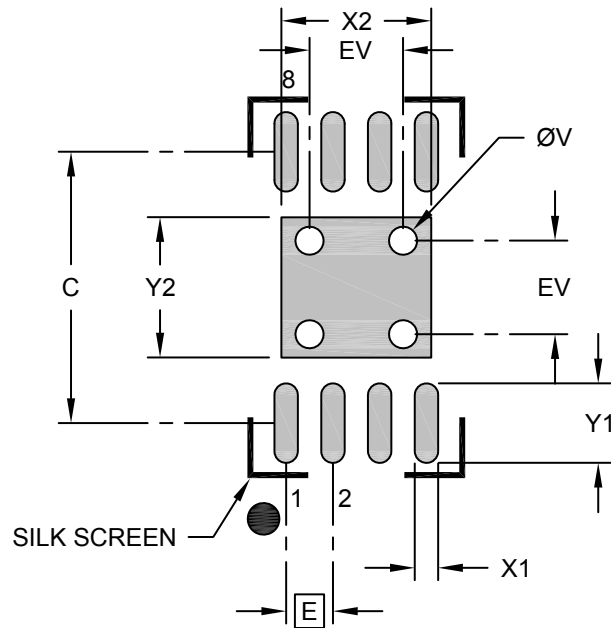

**RECOMMENDED LAND PATTERN**

Dimension Limits	Units	MILLIMETERS		
		MIN	NOM	MAX
Contact Pitch	E	0.50 BSC		
Optional Center Pad Width	X2			1.60
Optional Center Pad Length	Y2			1.50
Contact Pad Spacing	C		2.90	
Contact Pad Width (X8)	X1			0.25
Contact Pad Length (X8)	Y1			0.85
Thermal Via Diameter	V		0.30	
Thermal Via Pitch	EV		1.00	

**Notes:**

1. Dimensioning and tolerancing per ASME Y14.5M  
BSC: Basic Dimension. Theoretically exact value shown without tolerances.
2. For best soldering results, thermal vias, if used, should be filled or tented to avoid solder loss during reflow process

**Package Outlines and Dimensions**

**10-Lead Thin Plastic Dual Flat, No Lead Package (MN) - 3x3x0.8mm Body [TDFN]**

**Note:** For the most current package drawings, please see the Microchip Packaging Specification located at <http://www.microchip.com/packaging>

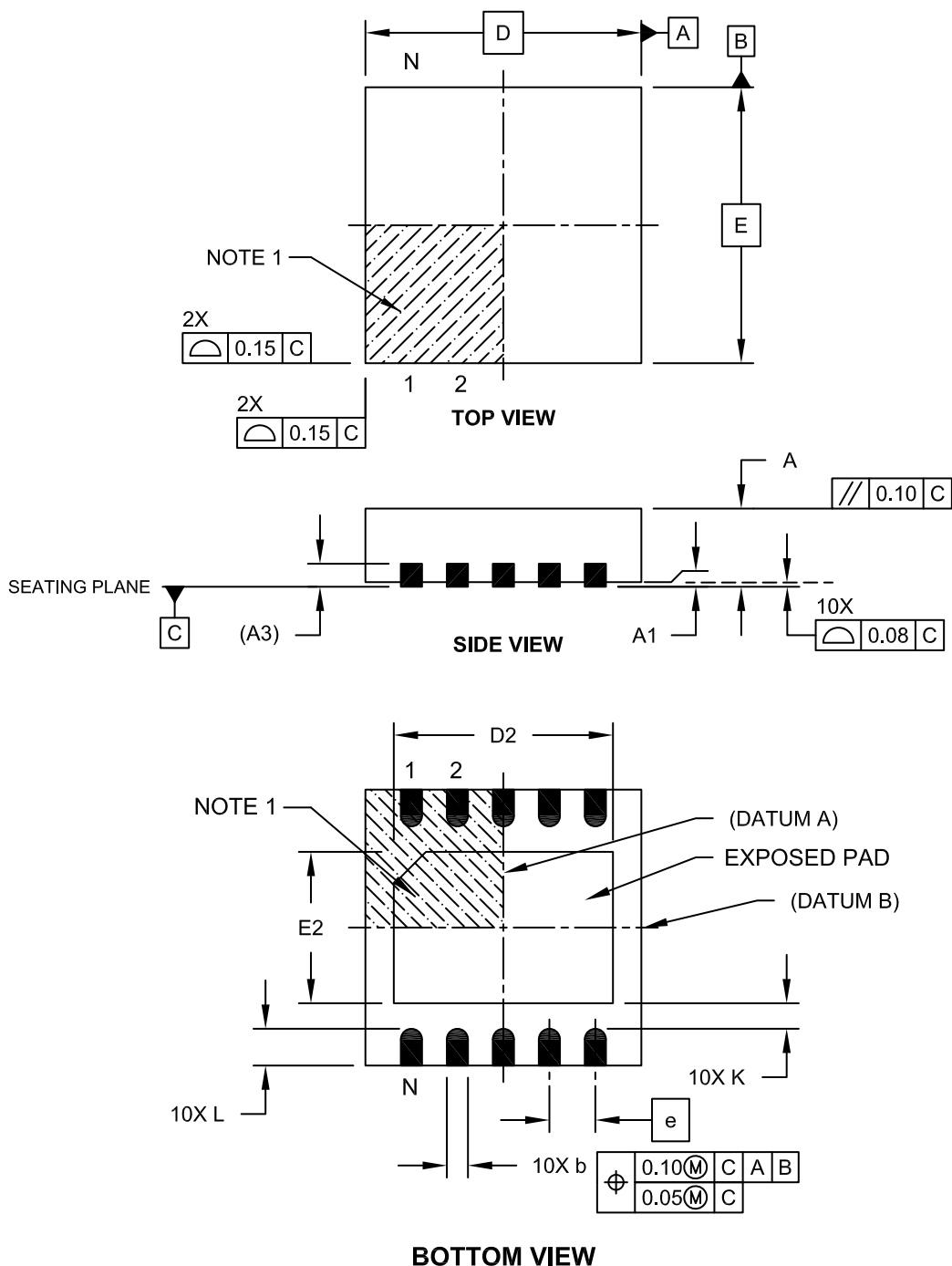

---



---

## Package Outlines and Dimensions

---



---

### 10-Lead Thin Plastic Dual Flat, No Lead Package (MN) - 3x3x0.8mm Body [TDFN]

**Note:** For the most current package drawings, please see the Microchip Packaging Specification located at <http://www.microchip.com/packaging>

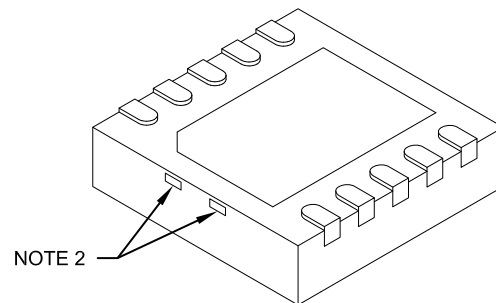

Dimension Limits	Units	MILLIMETERS		
		MIN	NOM	MAX
Number of Pins	N	10		
Pitch	e	0.50 BSC		
Overall Height	A	0.70	0.75	0.80
Standoff	A1	0.00	0.02	0.05
Contact Thickness	A3	0.20 REF		
Overall Length	D	3.00 BSC		
Exposed Pad Length	D2	2.20	2.30	2.35
Overall Width	E	3.00 BSC		
Exposed Pad Width	E2	1.55	1.65	1.70
Contact Width	b	0.18	0.25	0.30
Contact Length	L	0.30	0.40	0.50
Contact-to-Exposed Pad	K	0.20	-	-

**Notes:**

1. Pin 1 visual index feature may vary, but must be located within the hatched area.
2. Package may have one or more exposed tie bars at ends.
3. Package is saw singulated
4. Dimensioning and tolerancing per ASME Y14.5M
  - BSC: Basic Dimension. Theoretically exact value shown without tolerances.
  - REF: Reference Dimension, usually without tolerance, for information purposes only.



**MICROCHIP**

---

---

**Package Outlines and Dimensions**

---

---

NOTES:

---

---

**Package Outlines and Dimensions**

---

---

**TDFN-S**

**Package Outlines and Dimensions**

**8-Lead Plastic Very, Very Thin Small Outline No-Lead (MF) - 5x6 mm Body [TDFN-S]**

**Note:** For the most current package drawings, please see the Microchip Packaging Specification located at <http://www.microchip.com/packaging>

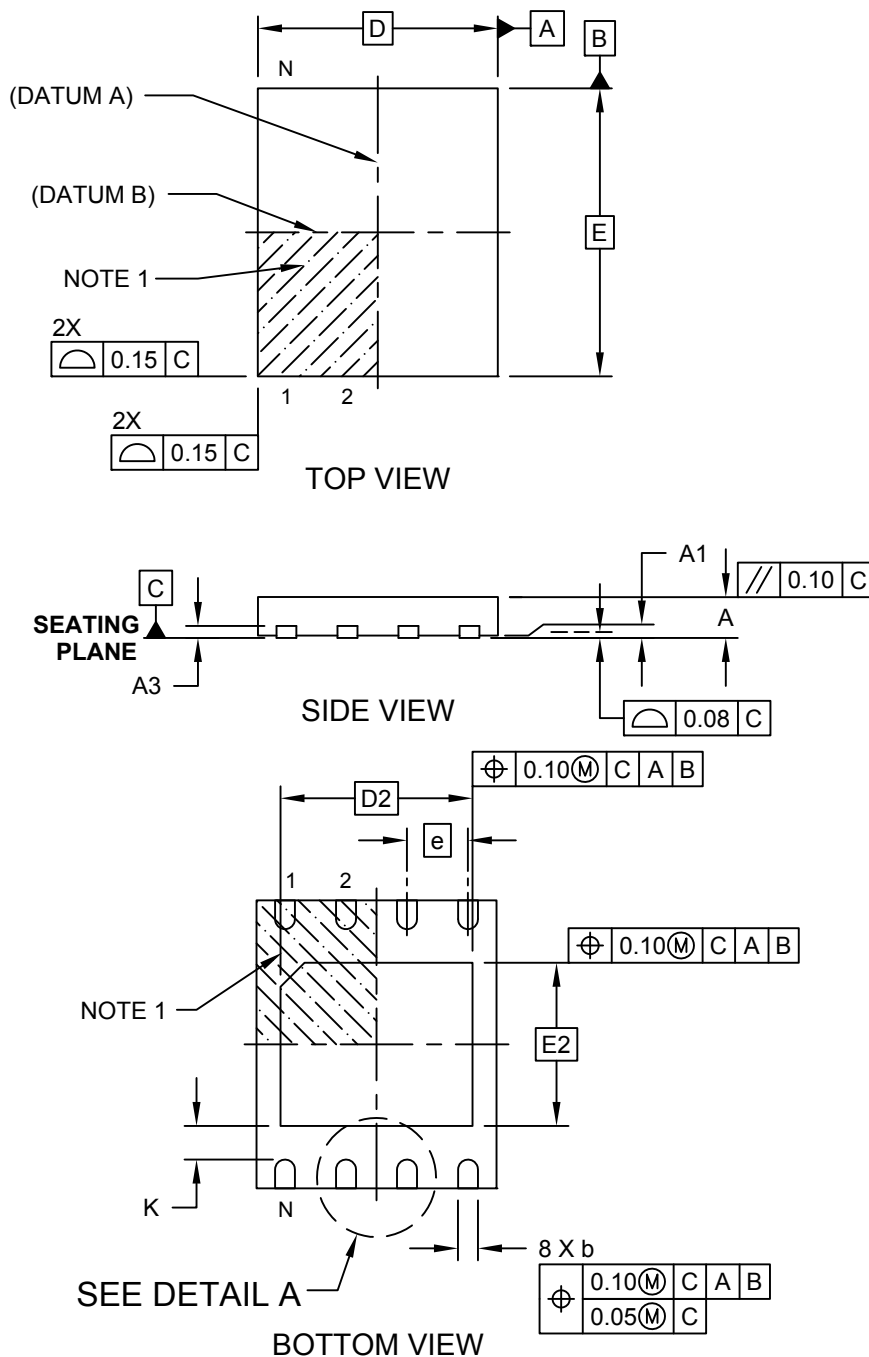

---



---

## Package Outlines and Dimensions

---



---

### 8-Lead Plastic Very, Very Thin Small Outline No-Lead (MF) - 5x6 mm Body [TDFN-S]

**Note:** For the most current package drawings, please see the Microchip Packaging Specification located at <http://www.microchip.com/packaging>

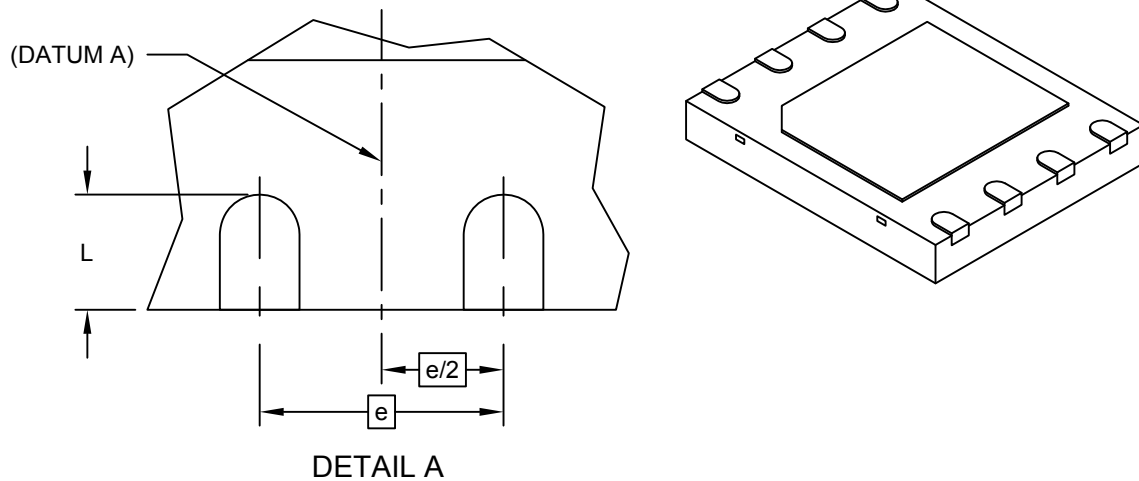

Dimension Limits	Units	MILLIMETERS		
		MIN	NOM	MAX
Number of Terminals	N	8		
Pitch	e	1.27 BSC		
Overall Height	A	0.70	0.75	0.80
Standoff	A1	0.00	0.02	0.05
Terminal Thickness	A3	0.20 REF		
Overall Width	D	5.00 BSC		
Exposed Pad Width	D2	4.00 BSC		
Overall Length	E	6.00 BSC		
Exposed Pad Length	E2	3.40 BSC		
Terminal Width	b	0.35	0.42	0.48
Terminal Length	L	0.50	0.60	0.70
Terminal-to-Exposed-Pad	K	0.20	-	-

**Notes:**

1. Pin 1 visual index feature may vary, but must be located within the hatched area.
2. Package is saw singulated
3. Dimensioning and tolerancing per ASME Y14.5M
  - BSC: Basic Dimension. Theoretically exact value shown without tolerances.
  - REF: Reference Dimension, usually without tolerance, for information purposes only.

**Footprint Outlines and Dimensions**

**8-Lead Plastic Very, Very Thin Small Outline No-Lead (MF) - 5x6 mm Body [TDFN-S]**

**Note:** For the most current package drawings, please see the Microchip Packaging Specification located at <http://www.microchip.com/packaging>

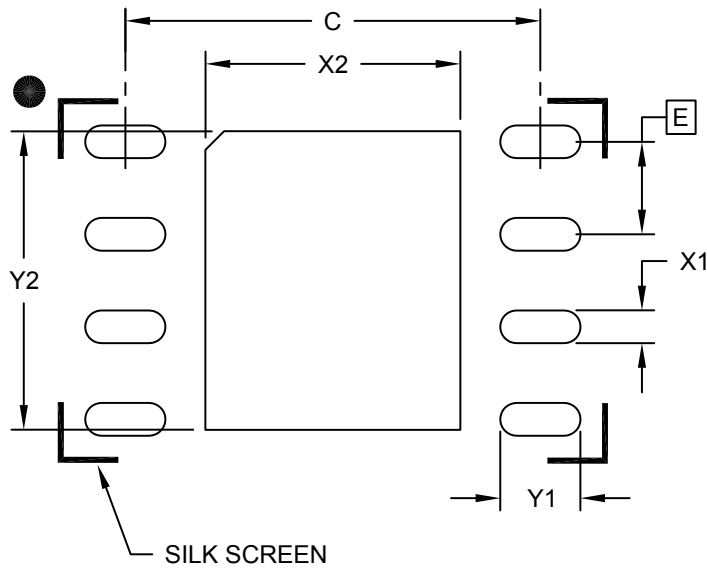

**RECOMMENDED LAND PATTERN**

Dimension Limits	Units	MILLIMETERS		
		MIN	NOM	MAX
Contact Pitch	E	1.27 BSC		
Optional Center Pad Width	X2			3.50
Optional Center Pad Length	Y2			4.10
Contact Pad Spacing	C		5.70	
Contact Pad Width (X8)	X1			0.45
Contact Pad Length (X8)	Y1			1.10

Notes:

1. Dimensioning and tolerancing per ASME Y14.5M

BSC: Basic Dimension. Theoretically exact value shown without tolerances.

Microchip Technology Drawing C04-2210A



---

---

**Package Outlines and Dimensions**

---

---

**UDFN**

## Package Outlines and Dimensions

### 8-Lead Plastic Dual Flat, No Lead Package (MU) – 2x3x0.5 mm Body [UDFN]

**Note:** For the most current package drawings, please see the Microchip Packaging Specification located at <http://www.microchip.com/packaging>

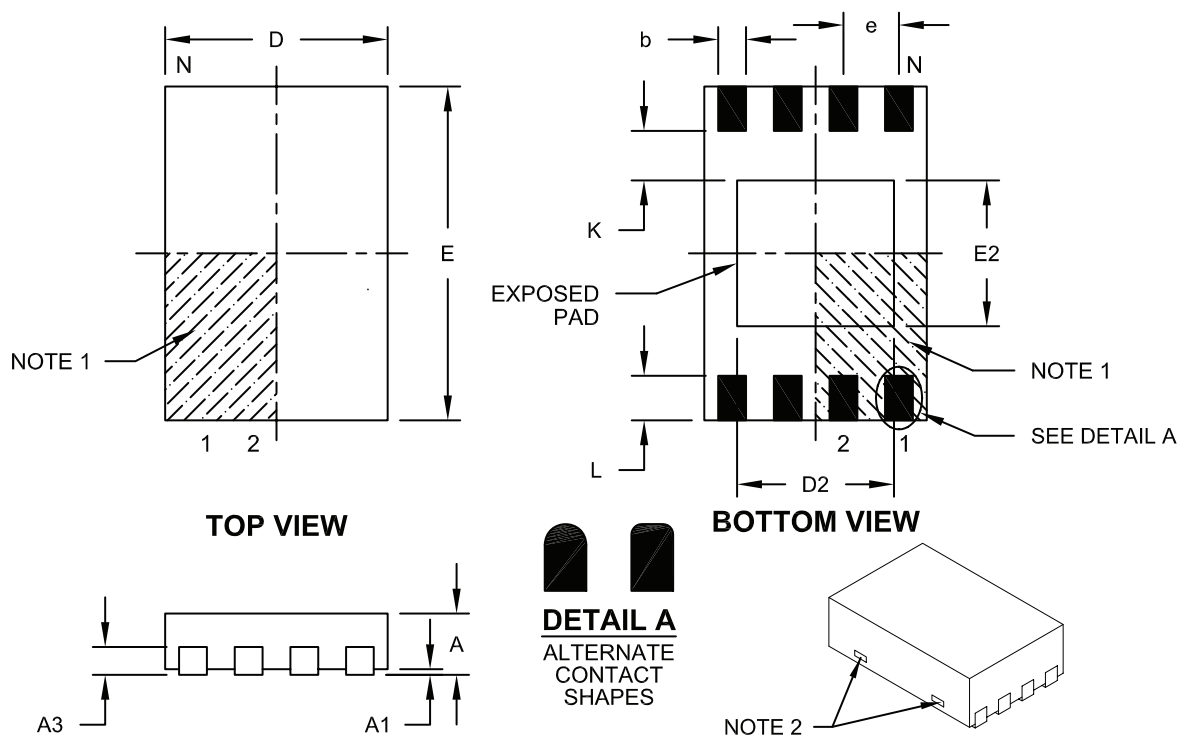

Dimension Limits	Units	MILLIMETERS		
		MIN	NOM	MAX
Number of Pins	N	8		
Pitch	e	0.50 BSC		
Overall Height	A	0.45	0.50	0.55
Standoff	A1			0.07
Contact Thickness	A3	0.127 REF		
Overall Length	D	1.95	2.00	2.05
Overall Width	E	2.95	3.00	3.05
Exposed Pad Length	D2	1.30	1.40	1.50
Exposed Pad Width	E2	1.20	1.30	1.40
Contact Width	b	0.20	0.25	0.30
Contact Length	L	0.25	0.30	0.35
Contact-to-Exposed Pad	K	0.55 REF		

**Notes:**

- Pin 1 visual index feature may vary, but must be located within the hatched area.
- Package may have one or more exposed tie bars at ends.
- Package is saw singulated
- Dimensioning and tolerancing per ASME Y14.5M

BSC: Basic Dimension. Theoretically exact value shown without tolerances.

REF: Reference Dimension, usually without tolerance, for information purposes only.

Microchip Technology Drawing No. C04-136B

---



---

## Footprint Outlines and Dimensions

---



---

### 8-Lead Plastic Dual Flat, No Lead Package (MU) – 2x3x0.5 mm Body [UDFN]

**Note:** For the most current package drawings, please see the Microchip Packaging Specification located at <http://www.microchip.com/packaging>

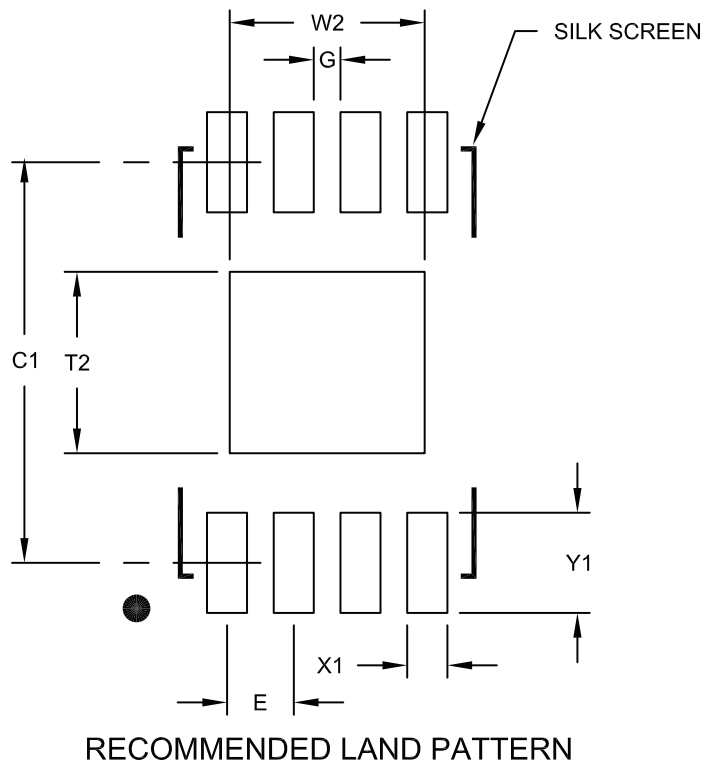

Dimension	Units	MILLIMETERS		
		MIN	NOM	MAX
Contact Pitch	E	0.50 BSC		
Optional Center Pad Width	W2			1.46
Optional Center Pad Length	T2			1.36
Contact Pad Spacing	C1		3.00	
Contact Pad Width (X8)	X1			0.30
Contact Pad Length (X8)	Y1			0.75
Distance Between Pads	G	0.20		

**Notes:**

1. Dimensioning and tolerancing per ASME Y14.5M

BSC: Basic Dimension. Theoretically exact value shown without tolerances.

Microchip Technology Drawing No. C04-2136A

**Package Outlines and Dimensions**

**8-Lead Plastic Ultra Thin Small Outline No Lead Package (NP) - 2x3 mm Body [USON]  
[Also called UDFN]**

**Note:** For the most current package drawings, please see the Microchip Packaging Specification located at <http://www.microchip.com/packaging>

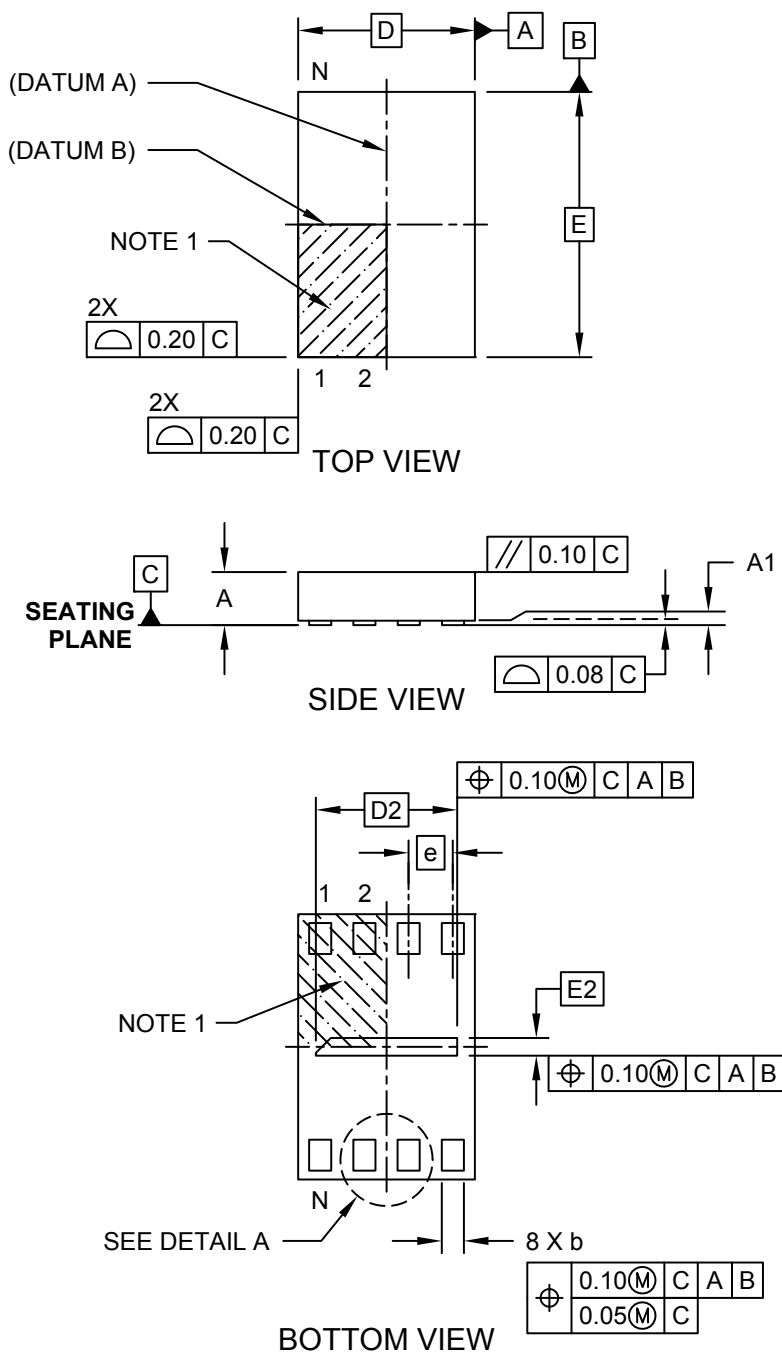

---



---

## Package Outlines and Dimensions

---



---

### 8-Lead Plastic Ultra Thin Small Outline No Lead Package (NP) - 2x3 mm Body [USON] [Also called UDFN]

**Note:** For the most current package drawings, please see the Microchip Packaging Specification located at <http://www.microchip.com/packaging>

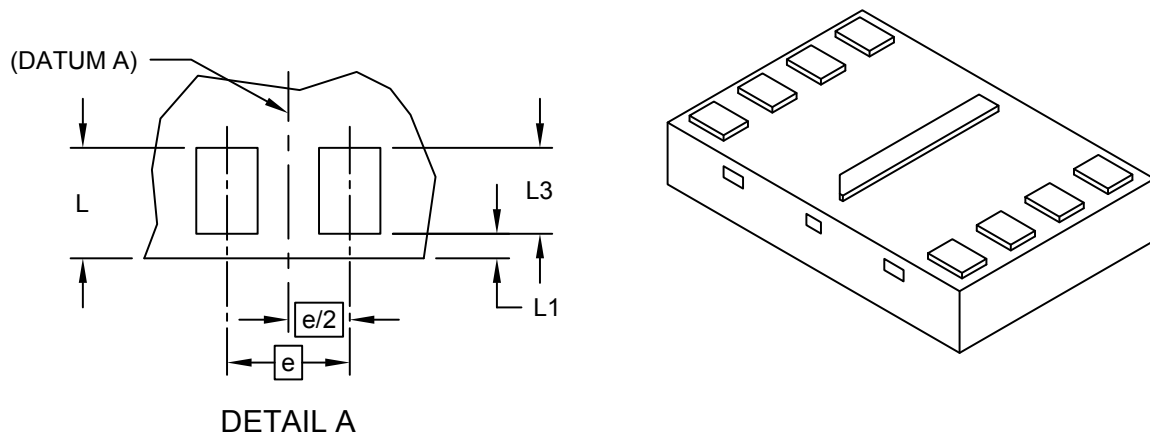

		MILLIMETERS		
Units				
Dimension Limits		MIN	NOM	MAX
Number of Terminals	N	8		
Pitch	e	0.50 BSC		
Overall Height	A	0.45	0.55	0.60
Standoff	A1	0.00	0.02	0.05
Overall Width	D	2.00 BSC		
Exposed Pad Width	D2	1.50	1.60	1.70
Overall Length	E	3.00 BSC		
Exposed Pad Length	E2	0.10	0.20	0.30
Terminal Width	b	0.20	0.25	0.30
Package Edge to Terminal Edge	L	0.40	0.45	0.50
Package Edge to Terminal Edge	L1	—	0.10	—
Terminal Length	L3	0.30	0.35	0.40

**Notes:**

1. Pin 1 visual index feature may vary, but must be located within the hatched area.
2. Package is saw singulated
3. Dimensioning and tolerancing per ASME Y14.5M

BSC: Basic Dimension. Theoretically exact value shown without tolerances.

REF: Reference Dimension, usually without tolerance, for information purposes only.

**Footprint Outlines and Dimensions**

**8-Lead Plastic Ultra Thin Small Outline No Lead Package (NP) - 2x3 mm Body [USON]  
[Also called UDFN]**

**Note:** For the most current package drawings, please see the Microchip Packaging Specification located at <http://www.microchip.com/packaging>

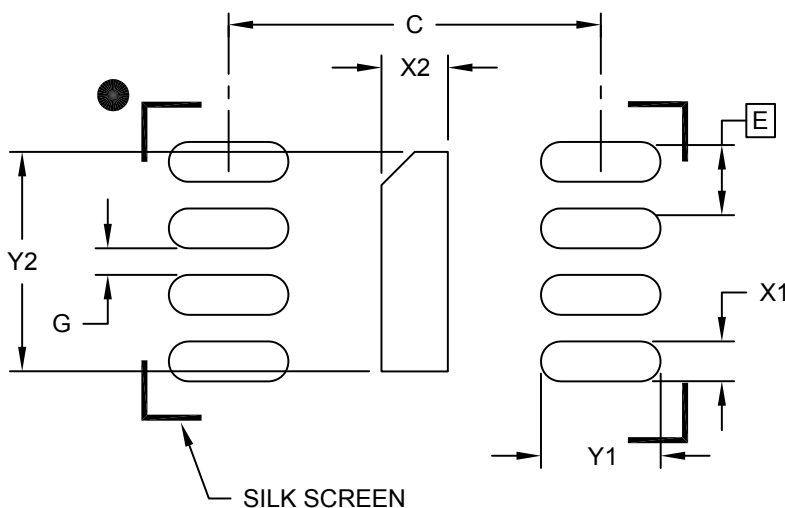

**RECOMMENDED LAND PATTERN**

Units		MILLIMETERS		
Dimension Limits		MIN	NOM	MAX
Terminal Pitch	E	0.50 BSC		
Optional Center Pad Width	X2			0.25
Optional Center Pad Length	Y2			1.65
Terminal Pad Spacing	C		2.80	
Terminal Pad Width (X8)	X1			0.30
Terminal Pad Length (X8)	Y1			0.90
Minimum Between Terminal Pads	G	0.20		

**Notes:**

1. Dimensioning and tolerancing per ASME Y14.5M

BSC: Basic Dimension. Theoretically exact value shown without tolerances.

Microchip Technology Drawing C04-2203B [NP]

**Package Outlines and Dimensions**

**8-Lead Plastic Ultra Thin Small Outline No Lead Package (PRX) - 2x3 mm Body [USON]  
[Also called UDFN]**

**Note:** For the most current package drawings, please see the Microchip Packaging Specification located at <http://www.microchip.com/packaging>

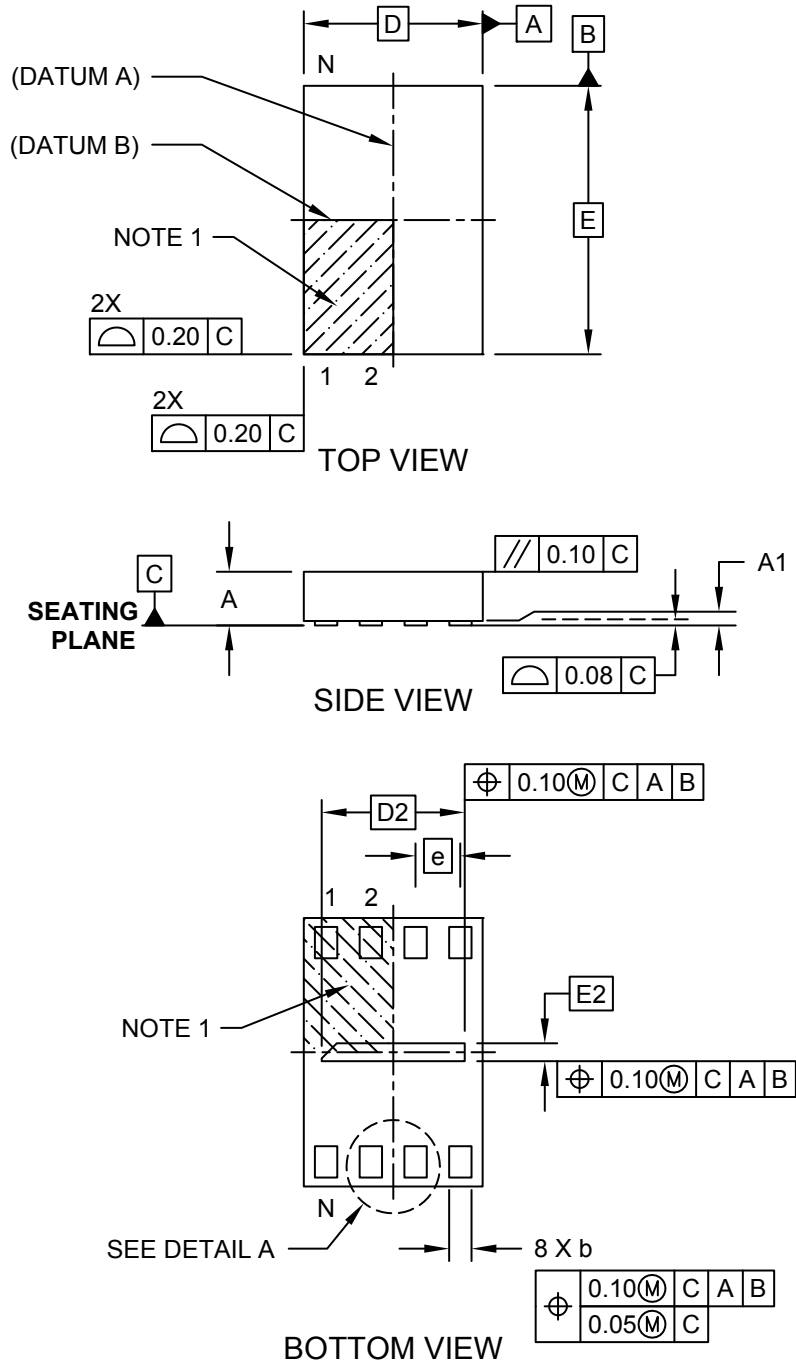

**Package Outlines and Dimensions**

**8-Lead Plastic Ultra Thin Small Outline No Lead Package (PRX) - 2x3 mm Body [USON]  
[Also called UDFN]**

**Note:** For the most current package drawings, please see the Microchip Packaging Specification located at <http://www.microchip.com/packaging>

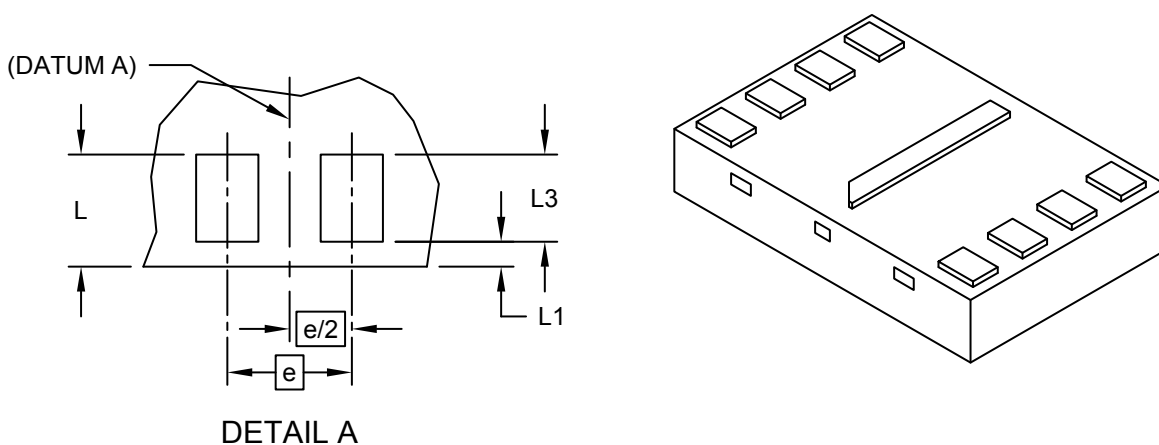

Dimension Limits	Units	MILLIMETERS		
		MIN	NOM	MAX
Number of Terminals	N	8		
Pitch	e	0.50 BSC		
Overall Height	A	0.45	0.55	0.60
Standoff	A1	0.00	0.02	0.05
Overall Width	D	2.00 BSC		
Exposed Pad Width	D2	1.50	1.60	1.70
Overall Length	E	3.00 BSC		
Exposed Pad Length	E2	0.10	0.20	0.30
Terminal Width	b	0.20	0.25	0.30
Package Edge to Terminal Edge	L	0.40	0.45	0.50
Package Edge to Terminal Edge	L1	—	0.10	—
Terminal Length	L3	0.30	0.35	0.40

**Notes:**

1. Pin 1 visual index feature may vary, but must be located within the hatched area.
2. Package is saw singulated
3. Dimensioning and tolerancing per ASME Y14.5M

BSC: Basic Dimension. Theoretically exact value shown without tolerances.

REF: Reference Dimension, usually without tolerance, for information purposes only.



---



---

## Footprint Outlines and Dimensions

---



---

### 8-Lead Plastic Ultra Thin Small Outline No Lead Package (PRX) - 2x3 mm Body [USON] [Also called UDFN]

**Note:** For the most current package drawings, please see the Microchip Packaging Specification located at <http://www.microchip.com/packaging>

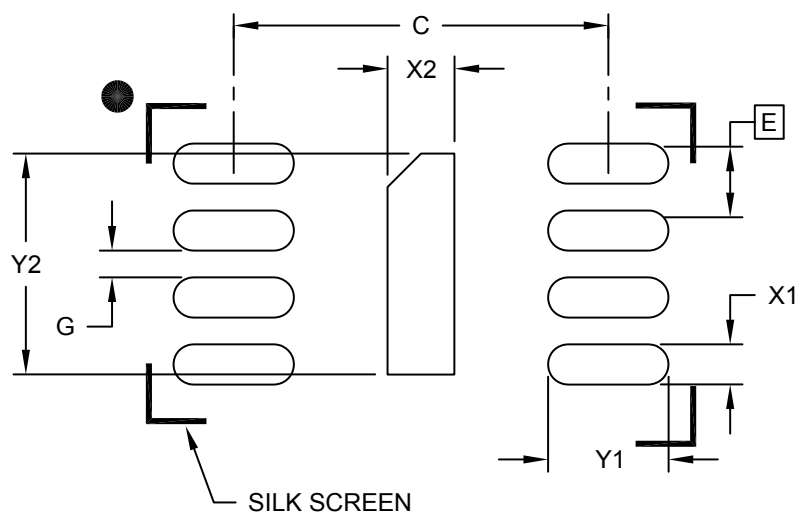

### RECOMMENDED LAND PATTERN

Dimension Limits	Units	MILLIMETERS		
		MIN	NOM	MAX
Terminal Pitch	E	0.50 BSC		
Optional Center Pad Width	X2			0.30
Optional Center Pad Length	Y2			1.70
Terminal Pad Spacing	C	2.80		
Terminal Pad Width (X8)	X1			0.30
Terminal Pad Length (X8)	Y1			0.90
Minimum Between Terminal Pads	G	0.20		

**Notes:**

1. Dimensioning and tolerancing per ASME Y14.5M

BSC: Basic Dimension. Theoretically exact value shown without tolerances.

Microchip Technology Drawing C04-2203B [PRX]

**Package Outlines and Dimensions**

**8-Lead Ultra Thin Plastic Dual Flat, No Lead Package (RF) - 3x3x0.50 mm Body [UDFN]**

**Note:** For the most current package drawings, please see the Microchip Packaging Specification located at <http://www.microchip.com/packaging>

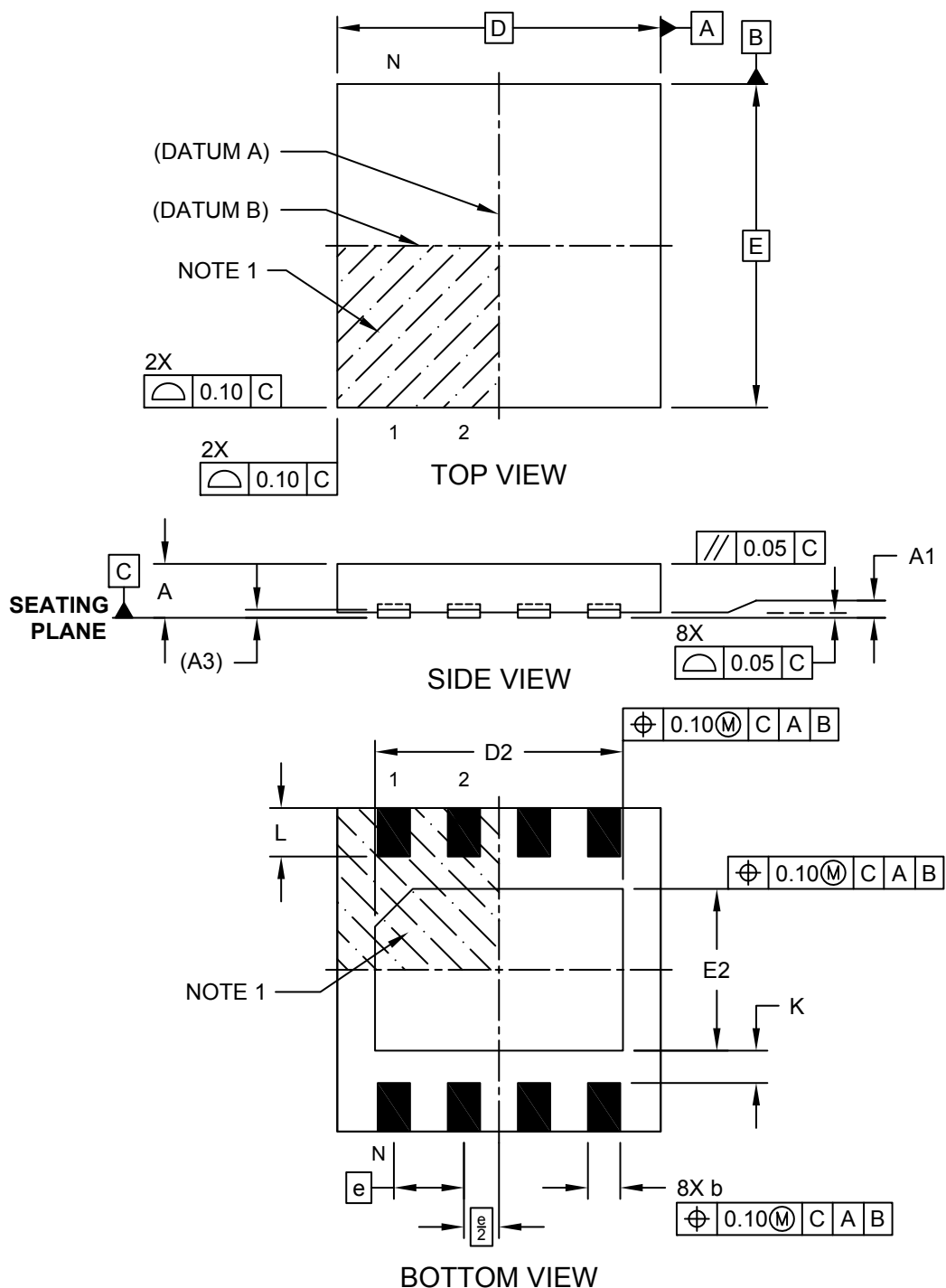

---



---

## Package Outlines and Dimensions

---



---

### 8-Lead Ultra Thin Plastic Dual Flat, No Lead Package (RF) - 3x3x0.50 mm Body [UDFN]

**Note:** For the most current package drawings, please see the Microchip Packaging Specification located at <http://www.microchip.com/packaging>

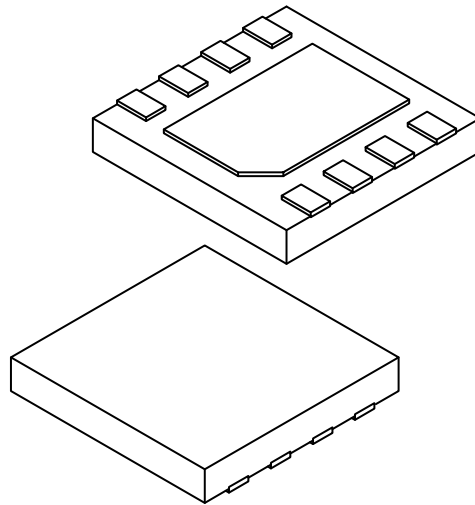

		Units	MILLIMETERS		
Dimension Limits			MIN	NOM	MAX
Number of Terminals	N		8		
Pitch	e		0.65 BSC		
Overall Height	A		0.45	0.50	0.55
Standoff	A1		0.00	0.02	0.05
Terminal Thickness	A3		0.065 REF		
Overall Width	E		3.00 BSC		
Exposed Pad Width	E2		1.40	1.50	1.60
Overall Length	D		3.00 BSC		
Exposed Pad Length	D2		2.20	2.30	2.40
Terminal Width	b		0.25	0.30	0.35
Terminal Length	L		0.35	0.45	0.55
Terminal-to-Exposed-Pad	K		0.20	-	-

**Notes:**

1. Pin 1 visual index feature may vary, but must be located within the hatched area.
2. Package is saw singulated
3. Dimensioning and tolerancing per ASME Y14.5M

BSC: Basic Dimension. Theoretically exact value shown without tolerances.

REF: Reference Dimension, usually without tolerance, for information purposes only.

**Footprint Outlines and Dimensions**

**8-Lead Ultra Thin Plastic Dual Flat, No Lead Package (RF) - 3x3x0.50 mm Body [UDFN]**

**Note:** For the most current package drawings, please see the Microchip Packaging Specification located at <http://www.microchip.com/packaging>

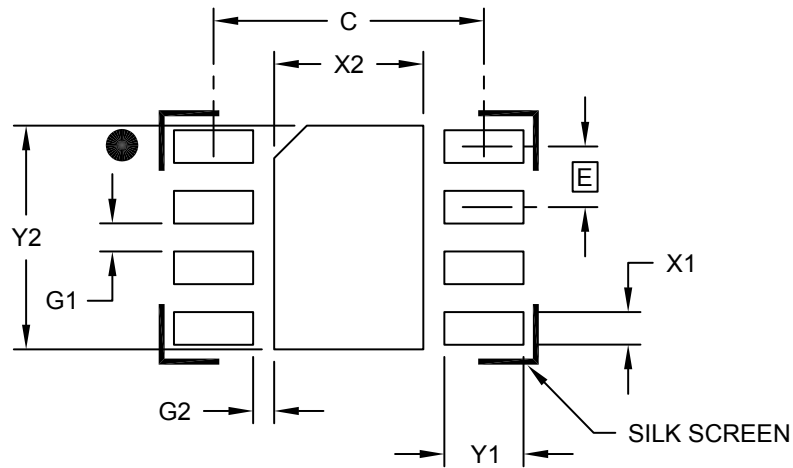

**RECOMMENDED LAND PATTERN**

		Units	MILLIMETERS		
Dimension Limits			MIN	NOM	MAX
Contact Pitch	E		0.65 BSC		
Optional Center Pad Width	X2				1.60
Optional Center Pad Length	Y2				2.40
Contact Pad Spacing	C		2.90		
Contact Pad Width (X8)	X1				0.35
Contact Pad Length (X8)	Y1				0.85
Contact Pad to Contact Pad (X6)	G1	0.20			
Contact Pad to Center Pad (X8)	G2	0.30			

**Notes:**

1. Dimensioning and tolerancing per ASME Y14.5M

BSC: Basic Dimension. Theoretically exact value shown without tolerances.

Microchip Technology Drawing C04-2254A

**Package Outlines and Dimensions**

**10-Lead Ultra-thin Dual Flatpack No-Lead (NA[Y]) – 3x3x0.5 mm Body [UDFN]**

**Note:** For the most current package drawings, please see the Microchip Packaging Specification located at <http://www.microchip.com/packaging>

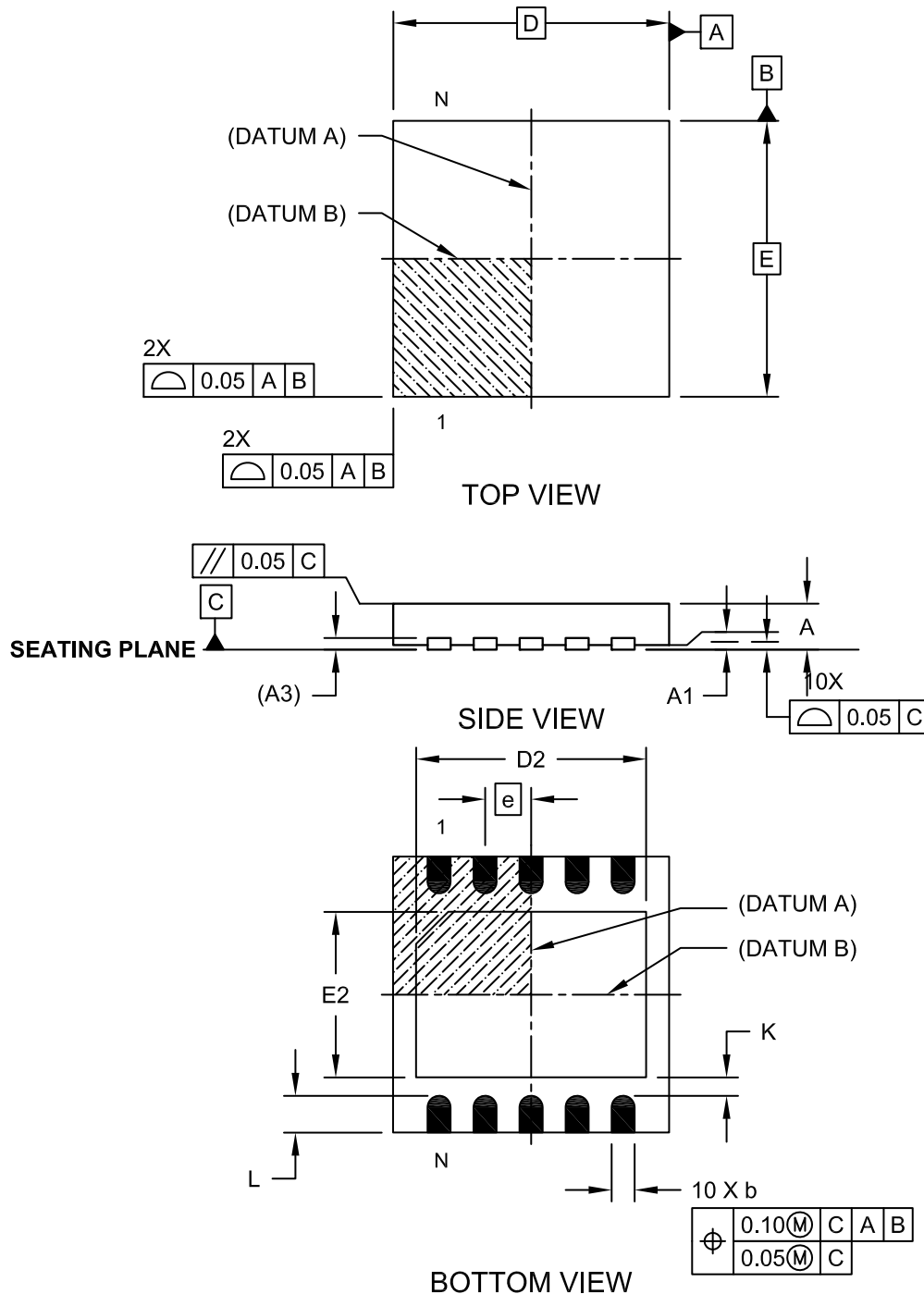

**Package Outlines and Dimensions**

**10-Lead Ultra-thin Dual Flatpack No-Lead (NA[Y]) – 3x3x0.5 mm Body [UDFN]**

**Note:** For the most current package drawings, please see the Microchip Packaging Specification located at <http://www.microchip.com/packaging>

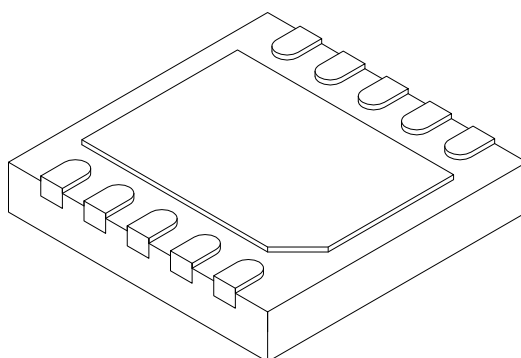

Dimension	Units Limits	MILLIMETERS		
		MIN	NOM	MAX
Number of Pins	N	10		
Pitch	e	0.50 BSC		
Overall Height	A	0.45	0.50	0.55
Standoff	A1	0.00	-	0.05
Overall Length	D	3.00 BSC		
Overall Width	E	3.00 BSC		
Exposed Pad Length	D2	2.40	2.50	2.60
Exposed Pad Width	E2	1.70	1.80	1.90
Terminal Thickness	(A3)	0.127 REF		
Terminal Width	b	0.20	0.25	0.30
Terminal Length	L	0.30	0.40	0.50
Terminal-to-Exposed Pad	K	0.20	-	-

**Notes:**

1. Pin 1 visual index feature may vary, but must be located within the hatched area.
2. Package may have one or more exposed tie bars at ends.
2. Package is saw singulated
4. Dimensioning and tolerancing per ASME Y14.5M.  
 BSC: Basic Dimension. Theoretically exact value shown without tolerances.  
 REF: Reference Dimension, usually without tolerance, for information purposes only.

---



---

## Footprint Outlines and Dimensions

---



---

### 10-Lead Ultra-thin Dual Flatpack, No Lead Package (NA[Y]) - 3x3 mm Body (UDFN)

**Note:** For the most current package drawings, please see the Microchip Packaging Specification located at <http://www.microchip.com/packaging>

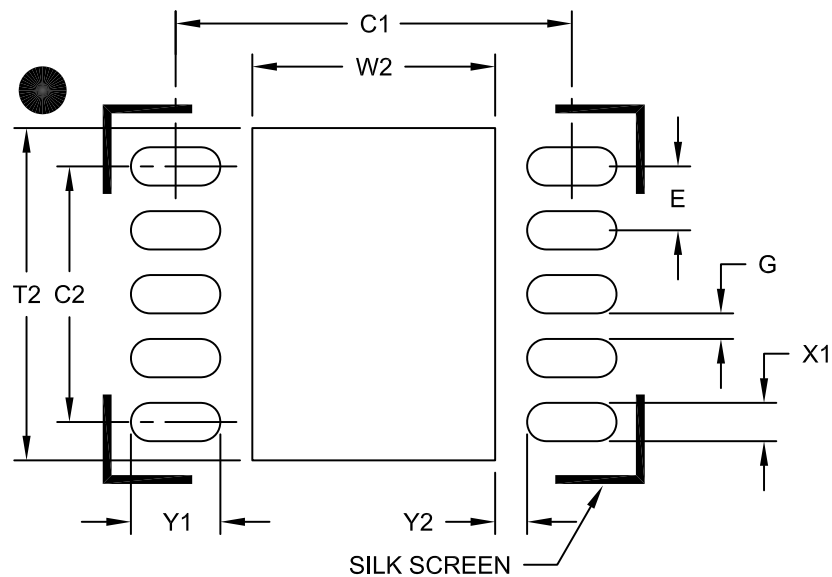

RECOMMENDED LAND PATTERN

Dimension Limits	Units	MILLIMETERS		
		MIN	NOM	MAX
Terminal Pitch	E	0.50 BSC		
Optional Center Pad Width	W2			1.90
Optional Center Pad Length	T2			2.60
Terminal Pad Spacing	C1		3.10	
Terminal Pad Spacing	C2		2.00	
Terminal Pad Width (X10)	X1			0.30
Terminal Pad Length (X10)	Y1			0.70
Terminal Pad to Center (X10)	Y2	0.25		
Distance Between Pads	G	0.20		

**Notes:**

1. Dimensioning and tolerancing per ASME Y14.5M

BSC: Basic Dimension. Theoretically exact value shown without tolerances.

Microchip Technology Drawing No. C04-2194A



**MICROCHIP**

---

---

**Package Outlines and Dimensions**

---

---

**NOTES:**



---

---

**Package Outlines and Dimensions**

---

---

**VDFN**

**Package Outlines and Dimensions**

**4-Lead Very Thin Plastic Dual Flatpack No-Lead (H4A) - 3.2x2.5 mm Body [VDFN]**

**Note:** For the most current package drawings, please see the Microchip Packaging Specification located at <http://www.microchip.com/packaging>

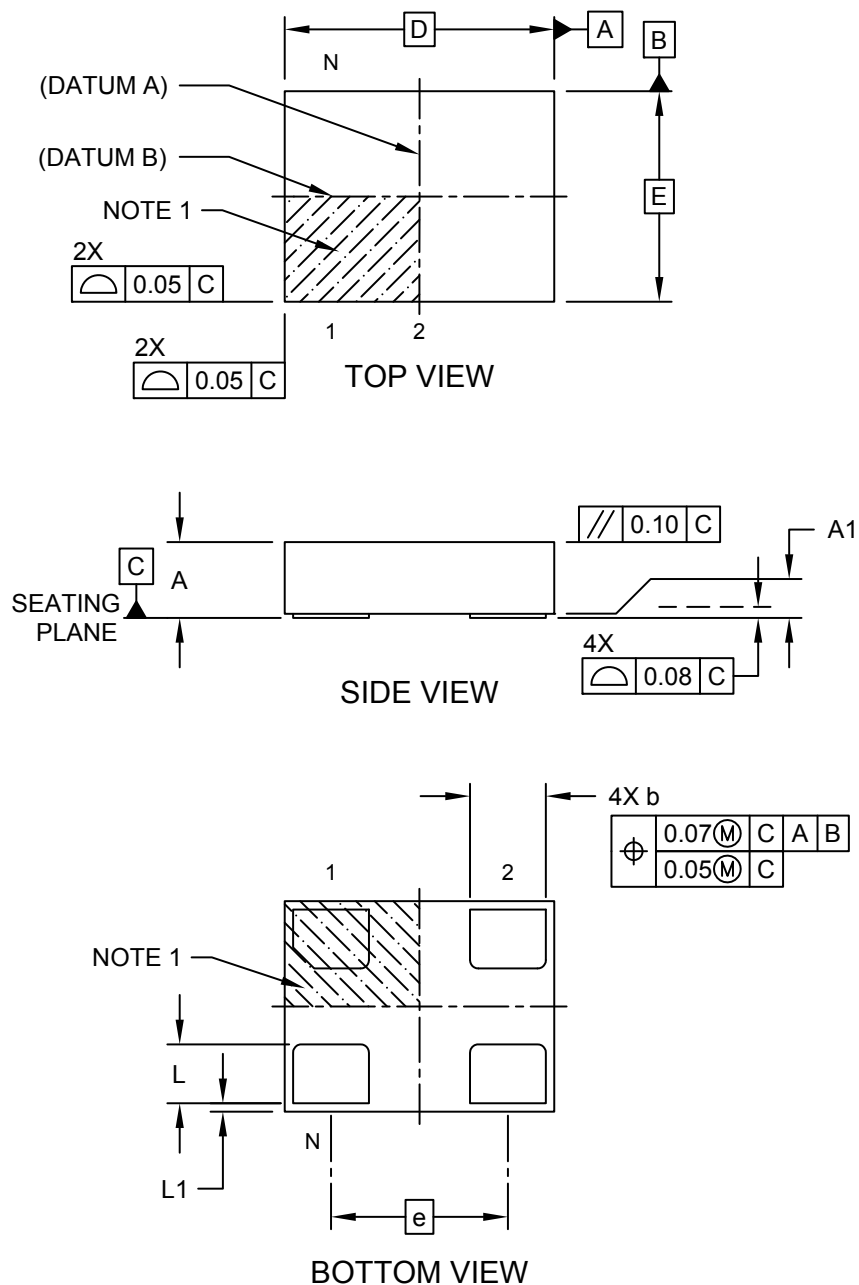

---



---

## Package Outlines and Dimensions

---



---

### 4-Lead Very Thin Plastic Dual Flatpack No-Lead (H4A) - 3.2x2.5 mm Body [VDFN]

**Note:** For the most current package drawings, please see the Microchip Packaging Specification located at <http://www.microchip.com/packaging>

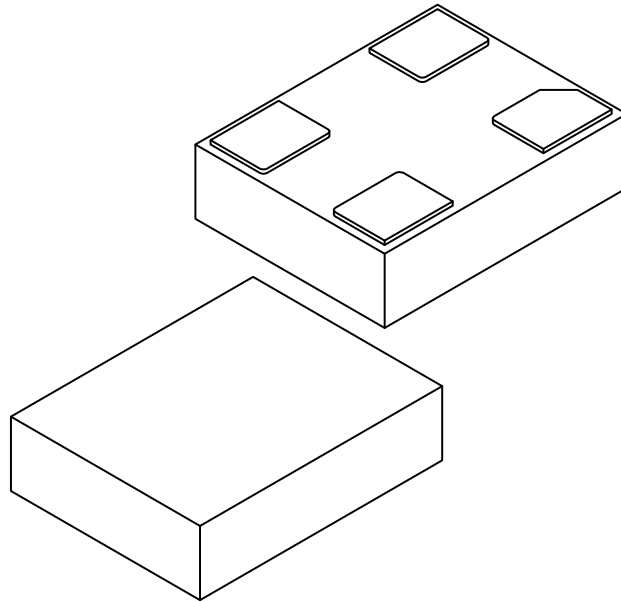

		MILLIMETERS		
Units				
Dimension Limits		MIN	NOM	MAX
Number of Terminals	N	4		
Pitch	e	2.10 BSC		
Overall Height	A	0.80	0.85	0.90
Standoff	A1	0.00	0.02	0.05
Overall Length	D	3.20 BSC		
Overall Width	E	2.50 BSC		
Terminal Width	b	0.85	0.90	0.95
Terminal Length	L	0.65	0.70	0.75
Terminal Pullback	L1	0.10 REF		

**Notes:**

1. Pin 1 visual index feature may vary, but must be located within the hatched area.
2. Package is saw singulated
3. Dimensioning and tolerancing per ASME Y14.5M

BSC: Basic Dimension. Theoretically exact value shown without tolerances.

REF: Reference Dimension, usually without tolerance, for information purposes only.

---



---

**Footprint Outlines and Dimensions**

---



---

**4-Lead Very Thin Plastic Dual Flatpack No-Lead (H4A) - 3.2x2.5 mm Body [VDFN]**

**Note:** For the most current package drawings, please see the Microchip Packaging Specification located at <http://www.microchip.com/packaging>

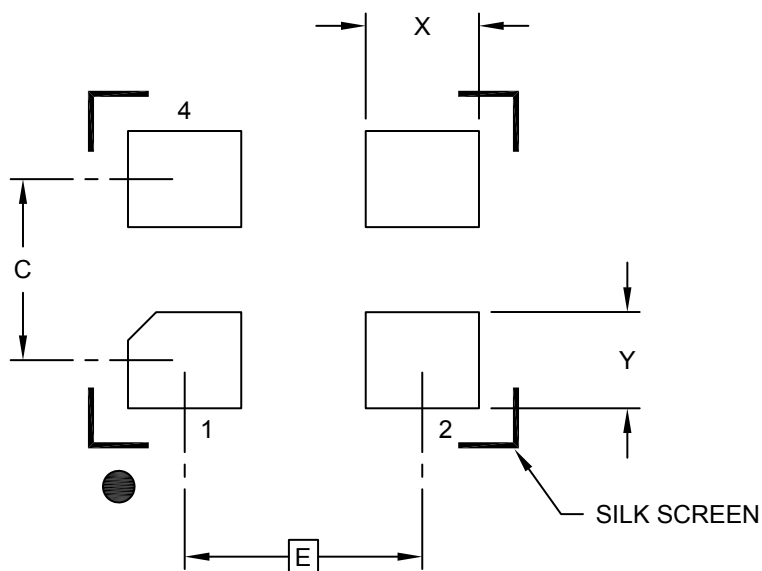

**RECOMMENDED LAND PATTERN**

Dimension Limits	Units	MILLIMETERS		
		MIN	NOM	MAX
Contact Pitch	E	2.10 BSC		
Contact Pad Spacing	C		1.60	
Contact Pad Width (X4)	X			1.00
Contact Pad Length (X4)	Y			0.85

**Notes:**

1. Dimensioning and tolerancing per ASME Y14.5M

BSC: Basic Dimension. Theoretically exact value shown without tolerances.

**Package Outlines and Dimensions**

**6-Lead Very Thin Dual Flatpack No-Leads (J7A) - 2.5x2.0 mm Body [VDFN]**

**Note:** For the most current package drawings, please see the Microchip Packaging Specification located at <http://www.microchip.com/packaging>

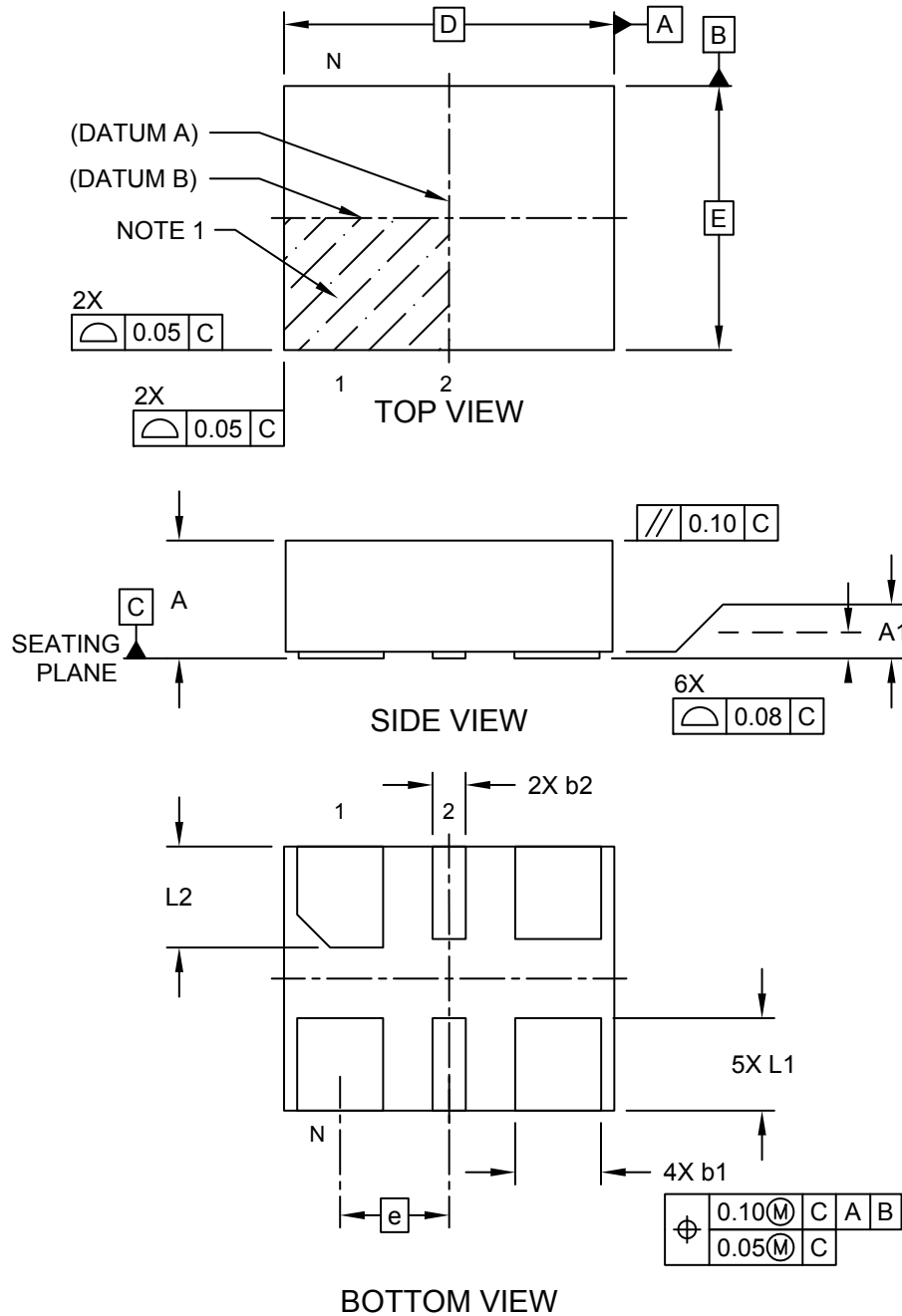

**Package Outlines and Dimensions**

**6-Lead Very Thin Dual Flatpack No-Leads (J7A) - 2.5x2.0 mm Body [VDFN]**

**Note:** For the most current package drawings, please see the Microchip Packaging Specification located at <http://www.microchip.com/packaging>

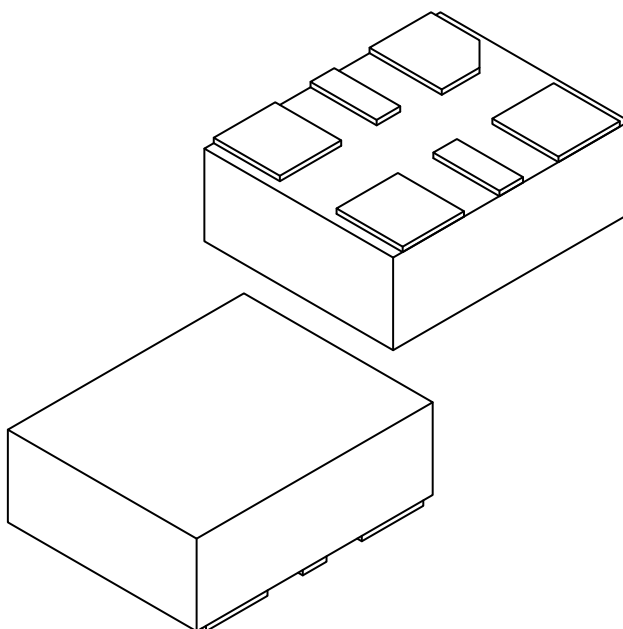

		Units	MILLIMETERS		
Dimension Limits			MIN	NOM	MAX
Number of Terminals	N		6		
Pitch	e		0.825 BSC		
Overall Height	A	0.80	0.85	0.90	
Standoff	A1	0.00	0.02	0.05	
Overall Length	D		2.50 BSC		
Overall Width	E		2.00 BSC		
Terminal Width	b1	0.60	0.65	0.70	
Terminal Width	b2	0.20	0.25	0.30	
Terminal Length	L1	0.60	0.70	0.80	
Terminal Length	L2	0.665	0.765	0.865	

Notes:

1. Pin 1 visual index feature may vary, but must be located within the hatched area.
2. Package is saw singulated
3. Dimensioning and tolerancing per ASME Y14.5M

BSC: Basic Dimension. Theoretically exact value shown without tolerances.

REF: Reference Dimension, usually without tolerance, for information purposes only.

---



---

## Footprint Outlines and Dimensions

---



---

### 6-Lead Very Thin Dual Flatpack No-Leads (J7A) - 2.5x2.0 mm Body [VDFN]

**Note:** For the most current package drawings, please see the Microchip Packaging Specification located at <http://www.microchip.com/packaging>

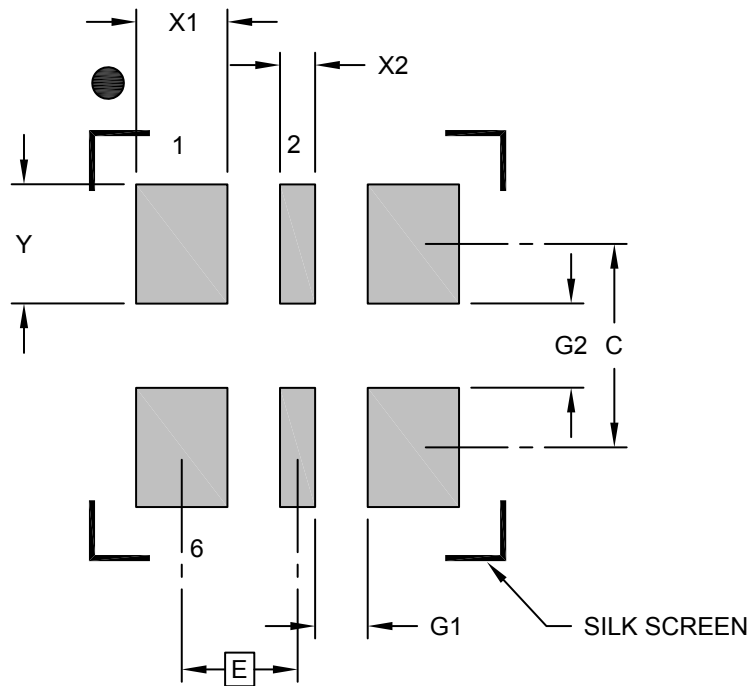

**RECOMMENDED LAND PATTERN**

Dimension Limits	Units	MILLIMETERS		
		MIN	NOM	MAX
Contact Pitch	E	0.825 BSC		
Contact Pad Width (X4)	X1			0.65
Contact Pad Width (X2)	X2			0.25
Contact Pad Length (X6)	Y			0.85
Contact Pad Spacing	C		1.45	
Space Between Contacts (X4)	G1	0.38		
Space Between Contacts (X3)	G2	0.60		

**Notes:**

1. Dimensioning and tolerancing per ASME Y14.5M  
BSC: Basic Dimension. Theoretically exact value shown without tolerances.
2. For best soldering results, thermal vias, if used, should be filled or tented to avoid solder loss during reflow process

**Package Outlines and Dimensions**

**6-Lead Very Thin Plastic Dual Flatpack No-Lead (H5A) - 3.2x2.5 mm Body [VDFN]**

**Note:** For the most current package drawings, please see the Microchip Packaging Specification located at <http://www.microchip.com/packaging>

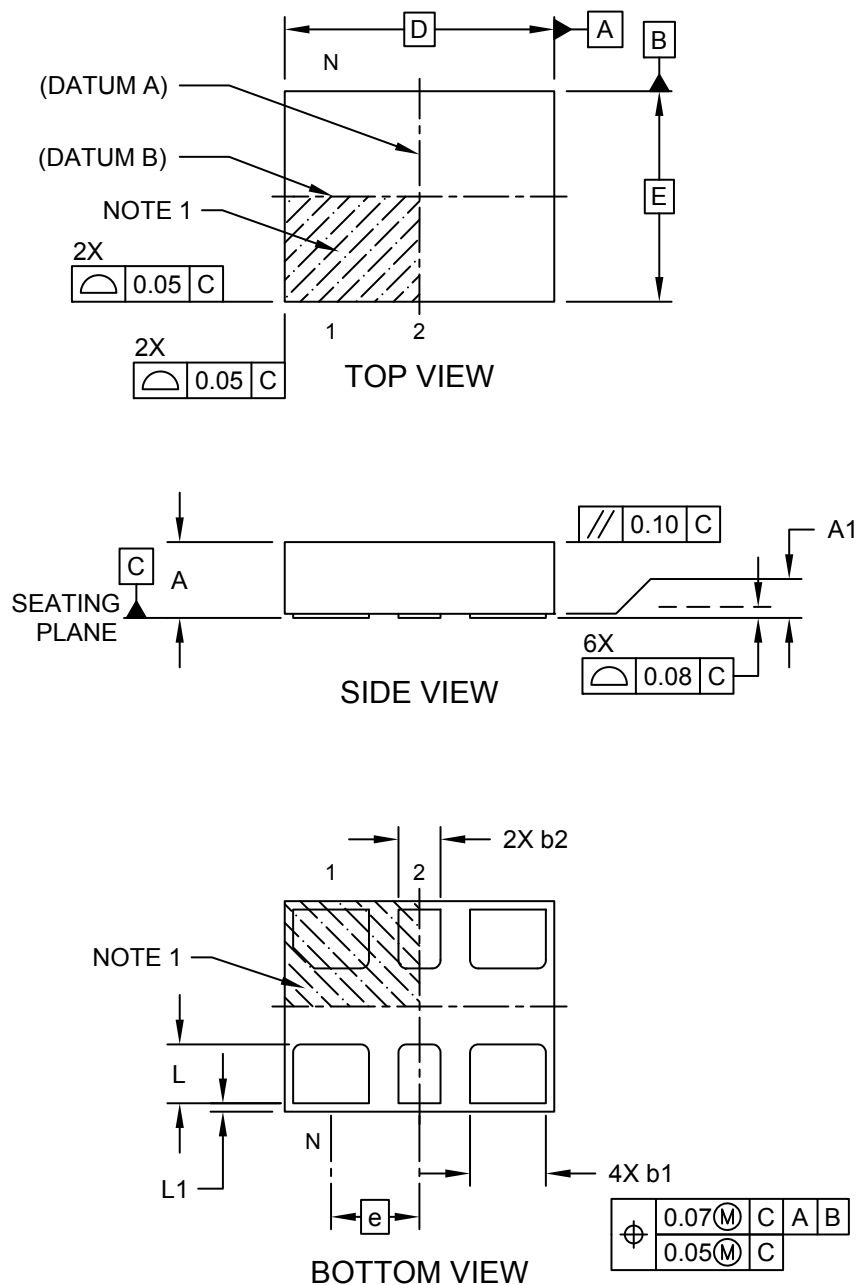



---



---

## Package Outlines and Dimensions

---



---

### 6-Lead Very Thin Plastic Dual Flatpack No-Lead (H5A) - 3.2x2.5 mm Body [VDFN]

**Note:** For the most current package drawings, please see the Microchip Packaging Specification located at <http://www.microchip.com/packaging>

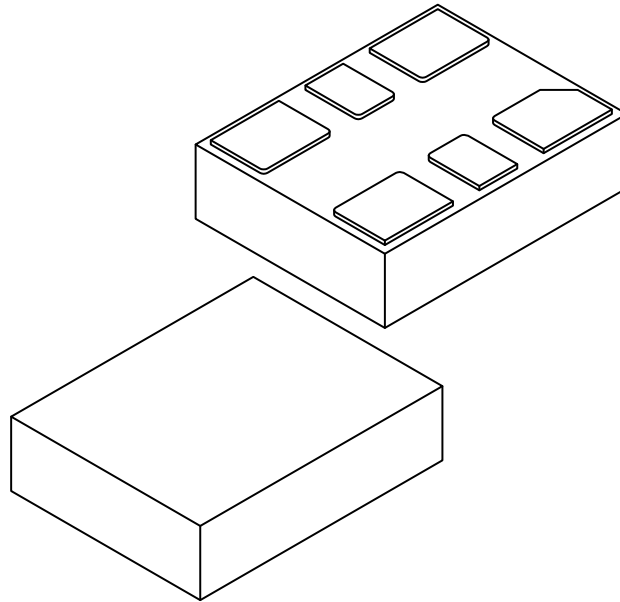

		Units	MILLIMETERS		
Dimension Limits			MIN	NOM	MAX
Number of Terminals	N		6		
Pitch	e		1.05 BSC		
Overall Height	A	0.80	0.85	0.90	
Standoff	A1	0.00	0.02	0.05	
Overall Length	D	3.20 BSC			
Overall Width	E	2.50 BSC			
Terminal Width	b1	0.85	0.90	0.95	
Terminal Width	b2	0.45	0.50	0.55	
Terminal Length	L	0.65	0.70	0.75	
Terminal Pullback	L1	0.10 REF			

**Notes:**

1. Pin 1 visual index feature may vary, but must be located within the hatched area.
2. Package is saw singulated
3. Dimensioning and tolerancing per ASME Y14.5M

BSC: Basic Dimension. Theoretically exact value shown without tolerances.

REF: Reference Dimension, usually without tolerance, for information purposes only.

**Footprint Outlines and Dimensions**

**6-Lead Very Thin Plastic Dual Flatpack No-Lead (H5A) - 3.2x2.5 mm Body [VDFN]**

**Note:** For the most current package drawings, please see the Microchip Packaging Specification located at <http://www.microchip.com/packaging>

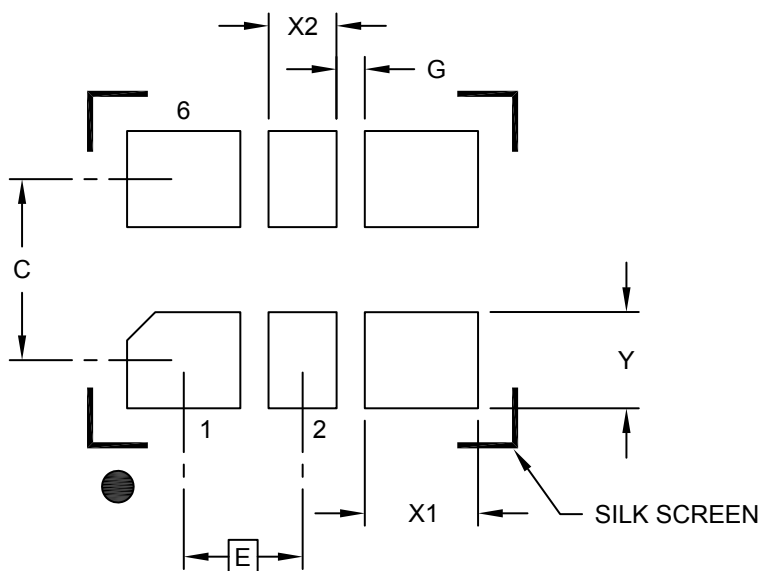

**RECOMMENDED LAND PATTERN**

Dimension Limits	Units	MILLIMETERS		
		MIN	NOM	MAX
Contact Pitch	E	1.05 BSC		
Contact Pad Spacing	C		1.60	
Contact Pad Width (X4)	X1			1.00
Contact Pad Width (X2)	X2			0.60
Contact Pad Length (X6)	Y			0.85
Space Between Contacts (X4)	G1	0.25		

**Notes:**

1. Dimensioning and tolerancing per ASME Y14.5M

BSC: Basic Dimension. Theoretically exact value shown without tolerances.

**Package Outlines and Dimensions**

**6-Lead Very Thin Plastic Quad Flat, No Lead Package (H8A) - 7x5 mm Body [VDFN]  
With 2.8x1.8 mm Exposed Pad**

**Note:** For the most current package drawings, please see the Microchip Packaging Specification located at <http://www.microchip.com/packaging>

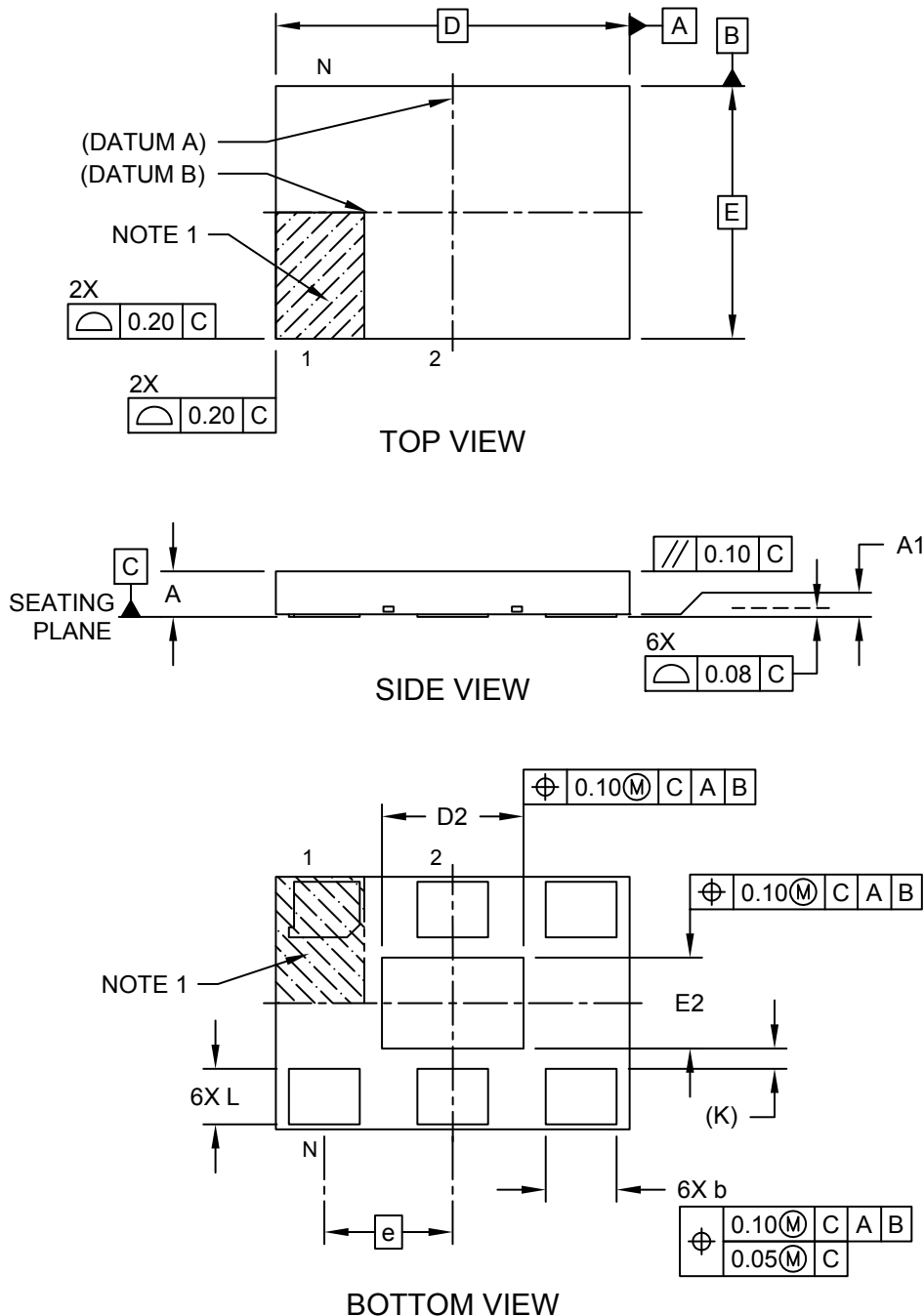

**Package Outlines and Dimensions**

**6-Lead Very Thin Plastic Quad Flat, No Lead Package (H8A) - 7x5 mm Body [VDFN]  
With 2.8x1.8 mm Exposed Pad**

**Note:** For the most current package drawings, please see the Microchip Packaging Specification located at <http://www.microchip.com/packaging>

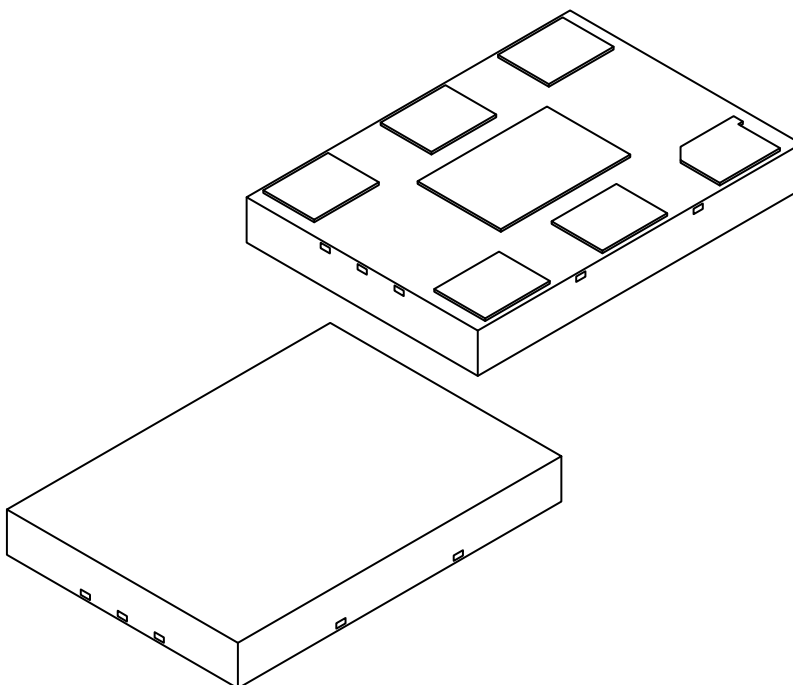

Dimension Limits	Units	MILLIMETERS		
		MIN	NOM	MAX
Number of Terminals	N	6		
Pitch	e	2.54		
Overall Height	A	0.80	0.85	0.90
Standoff	A1	0.00	0.02	0.05
Overall Length	D	7.00 BSC		
Exposed Pad Length	D2	2.70	2.80	2.90
Overall Width	E	5.00 BSC		
Exposed Pad Width	E2	1.70	1.80	1.90
Terminal Width	b	1.35	1.40	1.45
Terminal Length	L	1.00	1.10	1.20
Terminal-to-Exposed-Pad	K	0.20 REF		

**Notes:**

- Pin 1 visual index feature may vary, but must be located within the hatched area.
- Package is saw singulated
- Dimensioning and tolerancing per ASME Y14.5M
  - BSC: Basic Dimension. Theoretically exact value shown without tolerances.
  - REF: Reference Dimension, usually without tolerance, for information purposes only.

---



---

## Footprint Outlines and Dimensions

---



---

### 6-Lead Very Thin Plastic Quad Flat, No Lead Package (H8A) - 7x5 mm Body [VDFN] With 2.8x1.8 mm Exposed Pad

**Note:** For the most current package drawings, please see the Microchip Packaging Specification located at <http://www.microchip.com/packaging>

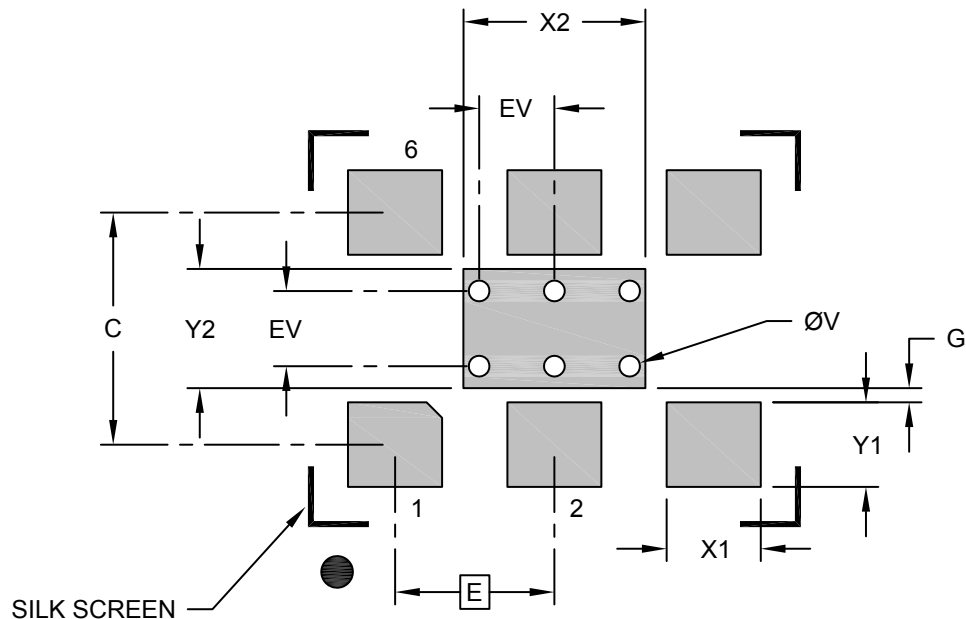

### RECOMMENDED LAND PATTERN

Dimension Limits	Units	MILLIMETERS		
		MIN	NOM	MAX
Contact Pitch	E	2.54 BSC		
Optional Center Pad Width	X2			2.90
Optional Center Pad Length	Y2			1.90
Contact Pad Spacing	C		3.70	
Contact Pad Width (X6)	X1			1.50
Contact Pad Length (X6)	Y1			1.35
Contact Pad to Center Pad (X2)	G	0.20		
Thermal Via Diameter (X6)	V		0.33	
Thermal Via Pitch	EV		1.20	

**Notes:**

1. Dimensioning and tolerancing per ASME Y14.5M  
BSC: Basic Dimension. Theoretically exact value shown without tolerances.
2. For best soldering results, thermal vias, if used, should be filled or tented to avoid solder loss during reflow process

**Package Outlines and Dimensions**

**8-Lead Very Thin Flat, Dual No Lead Package (LZ) - 2x2 mm Body [VDFN]  
With 1.7x0.9mm Exposed Pad**

**Note:** For the most current package drawings, please see the Microchip Packaging Specification located at <http://www.microchip.com/packaging>

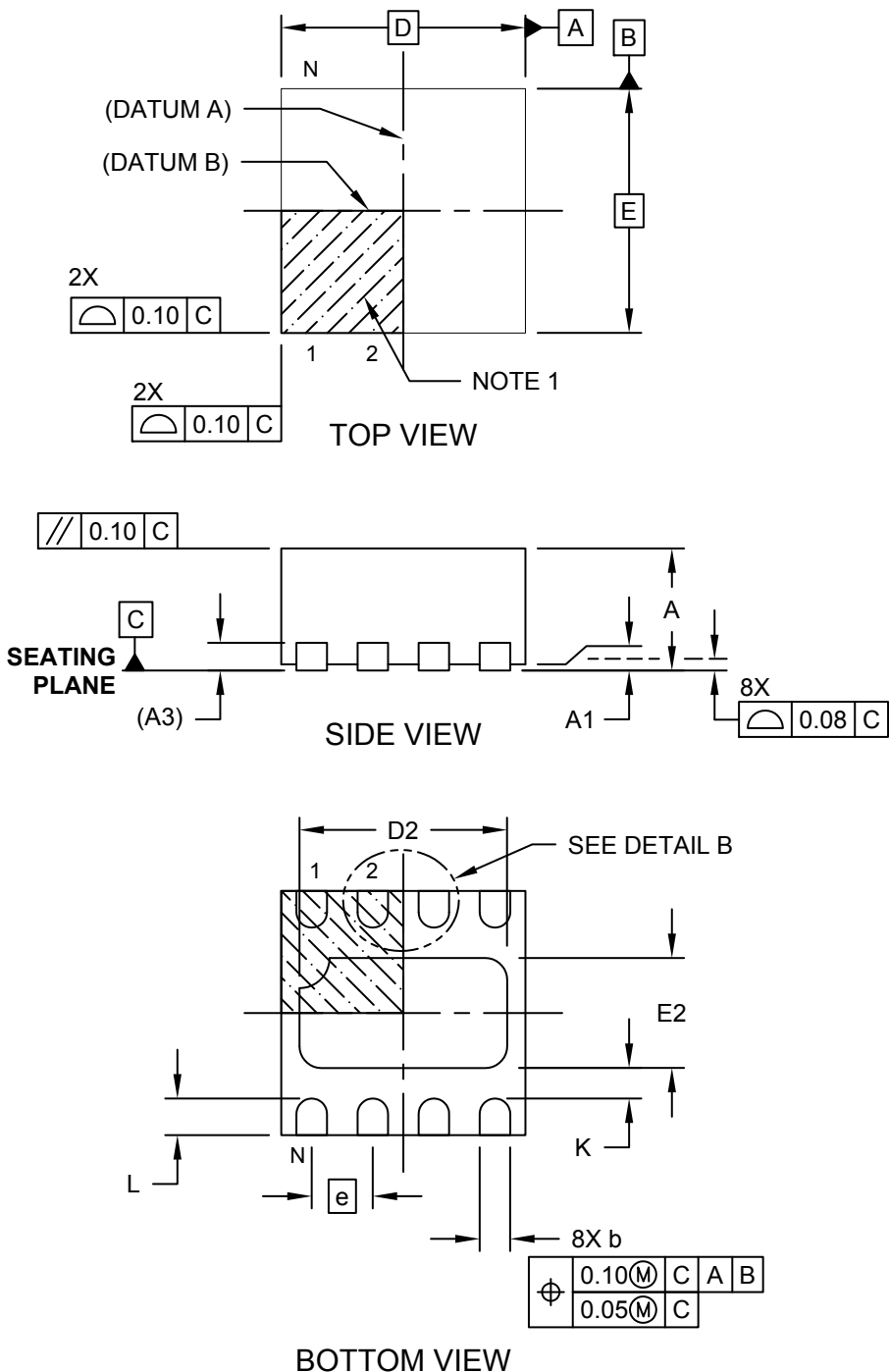

---



---

## Package Outlines and Dimensions

---



---

### 8-Lead Very Thin Flat, Dual No Lead Package (LZ) - 2x2 mm Body [VDFN] With 1.7x0.9mm Exposed Pad

**Note:** For the most current package drawings, please see the Microchip Packaging Specification located at <http://www.microchip.com/packaging>

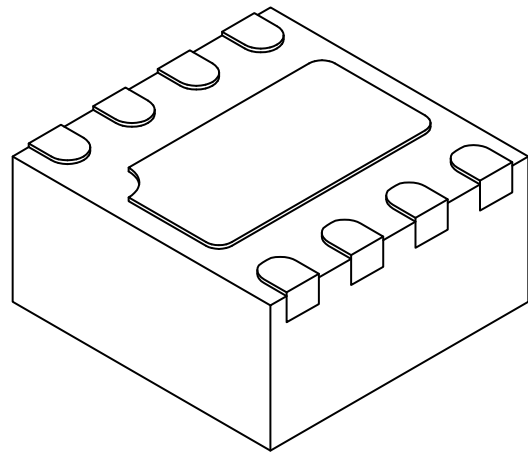
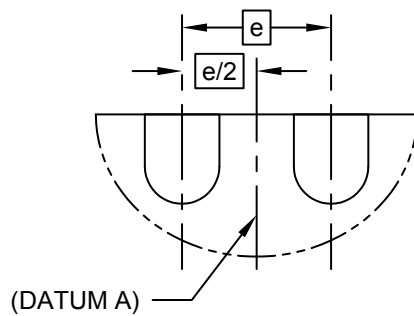

DETAIL B

		MILLIMETERS		
Units				
Dimension Limits		MIN	NOM	MAX
Number of Pins	N	8		
Pitch	e	0.50 BSC		
Overall Height	A	0.80	0.90	1.00
Standoff	A1	0.00	0.02	0.05
Terminal Thickness (REF)	(A3)	0.20 (REF)		
Overall Width	D	2.00 BSC		
Exposed Pad Width	D2	1.55	1.70	1.80
Overall Length	E	2.00 BSC		
Exposed Pad Length	E2	0.75	0.90	1.00
Terminal Width	b	0.18	0.25	0.30
Terminal Length	L	0.20	0.30	0.40
Terminal-to-Exposed Pad	K	0.20	-	-

**Notes:**

1. Pin 1 visual index feature may vary, but must be located within the hatched area.
2. Package may have one or more exposed tie bars at ends.
3. Package is saw singulated
3. Dimensioning and tolerancing per ASME Y14.5M.
  - BSC: Basic Dimension. Theoretically exact value shown without tolerances.
  - REF: Reference Dimension, usually without tolerance, for information purposes only.

**Footprint Outlines and Dimensions**

**8-Lead Very Thin Flat, Dual No Lead Package (LZ) - 2x2 mm Body [VDFN]  
With 1.7x0.9mm Exposed Pad**

**Note:** For the most current package drawings, please see the Microchip Packaging Specification located at <http://www.microchip.com/packaging>

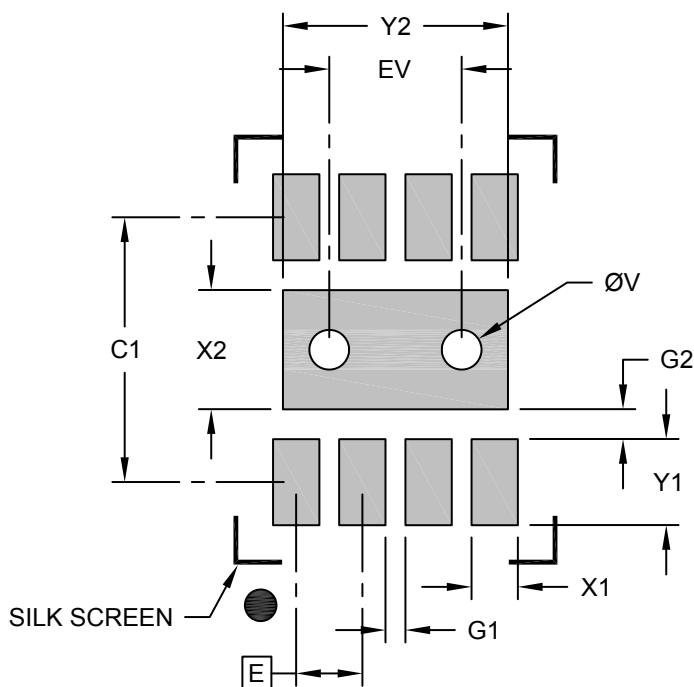

**RECOMMENDED LAND PATTERN**

Dimension Limits	Units	MILLIMETERS		
		MIN	NOM	MAX
Contact Pitch	E	0.50 BSC		
Optional Center Pad Width	W1			1.70
Optional Center Pad Length	T2			0.90
Contact Pad Spacing	C1		2.00	
Contact Pad Width (X28)	X1			0.35
Contact Pad Length (X28)	Y1			0.65
Distance Between Pads	G1	0.15		
Distance Between Pads	G2	0.23		
Thermal Via Diameter	V		0.30	
Thermal Via Pitch	EV		1.00	

**Notes:**

1. Dimensioning and tolerancing per ASME Y14.5M  
BSC: Basic Dimension. Theoretically exact value shown without tolerances.
2. For best soldering results, thermal vias, if used, should be filled or tented to avoid solder loss during reflow process



**Package Outlines and Dimensions**

**8-Lead Very Thin Plastic Dual Flat, No Lead Package (J8A) - 2x2 mm Body [VDFN]  
With 1.7x0.9 mm Exposed Pad**

**Note:** For the most current package drawings, please see the Microchip Packaging Specification located at <http://www.microchip.com/packaging>

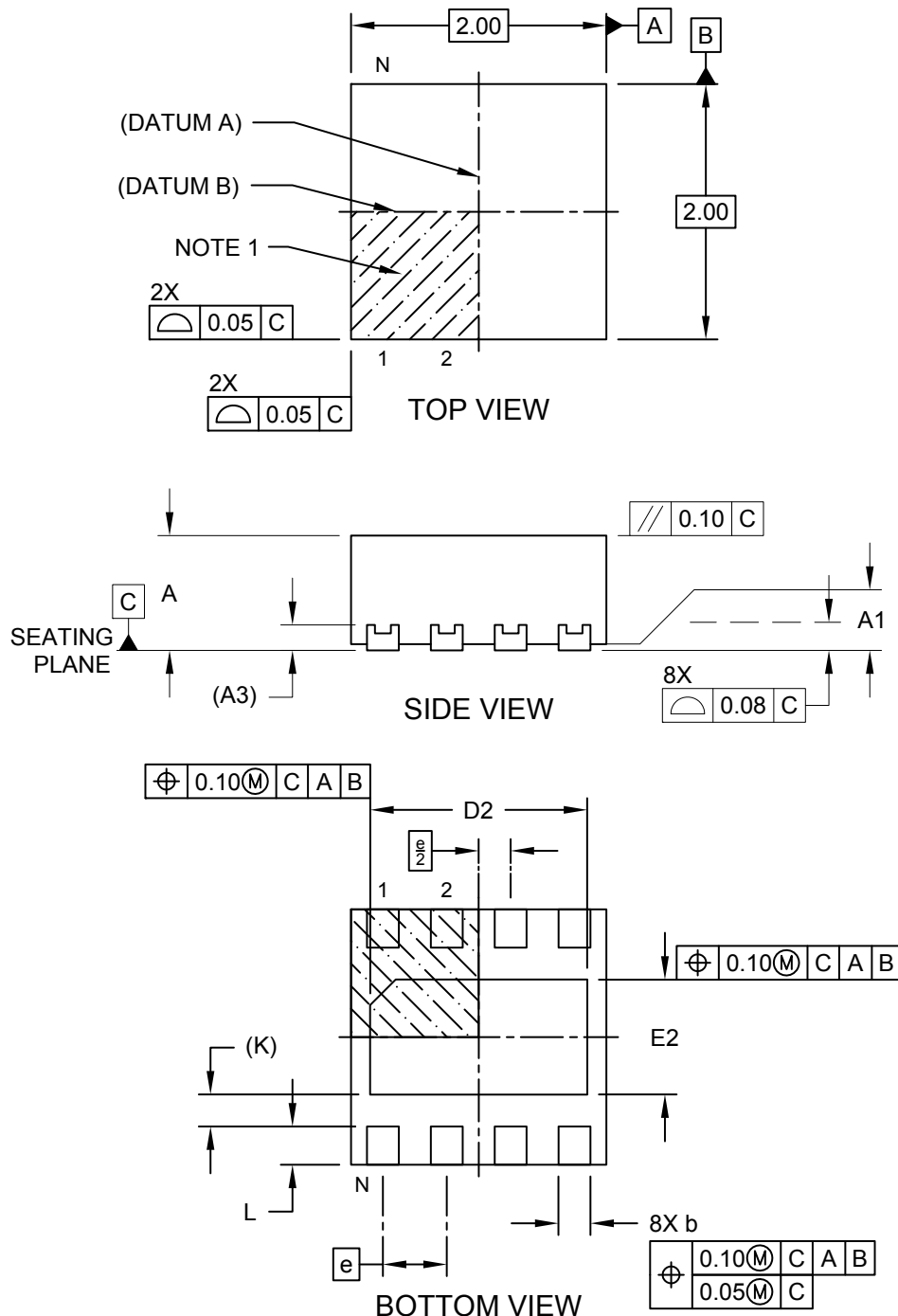

**Package Outlines and Dimensions**

**8-Lead Very Thin Plastic Dual Flat, No Lead Package (J8A) - 2x2 mm Body [VDFN]  
With 1.7x0.9 mm Exposed Pad**

**Note:** For the most current package drawings, please see the Microchip Packaging Specification located at <http://www.microchip.com/packaging>

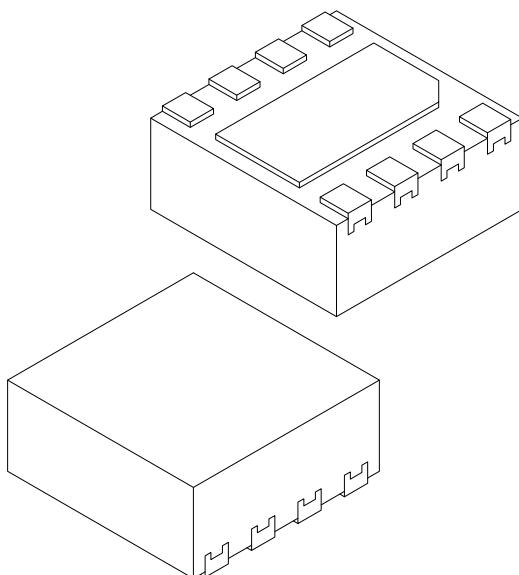

		Units	MILLIMETERS		
Dimension Limits			MIN	NOM	MAX
Number of Terminals	N		8		
Pitch	e		0.50 BSC		
Overall Height	A	0.80	0.85	0.90	
Standoff	A1	0.00	0.02	0.05	
Terminal Thickness	A3	0.20 REF			
Overall Length	D	2.00 BSC			
Exposed Pad Length	D2	1.65	1.70	1.75	
Overall Width	E	2.00 BSC			
Exposed Pad Width	E2	0.85	0.90	0.95	
Terminal Width	b	0.20	0.25	0.30	
Terminal Length	L	0.25	0.30	0.35	
Terminal-to-Exposed-Pad	K	0.25 REF			

**Notes:**

1. Pin 1 visual index feature may vary, but must be located within the hatched area.
2. Package is saw singulated
3. Dimensioning and tolerancing per ASME Y14.5M

BSC: Basic Dimension. Theoretically exact value shown without tolerances.

REF: Reference Dimension, usually without tolerance, for information purposes only.

---



---

## Footprint Outlines and Dimensions

---



---

### 8-Lead Very Thin Plastic Dual Flat, No Lead Package (J8A) - 2x2 mm Body [VDFN] With 1.7x0.9 mm Exposed Pad

**Note:** For the most current package drawings, please see the Microchip Packaging Specification located at <http://www.microchip.com/packaging>

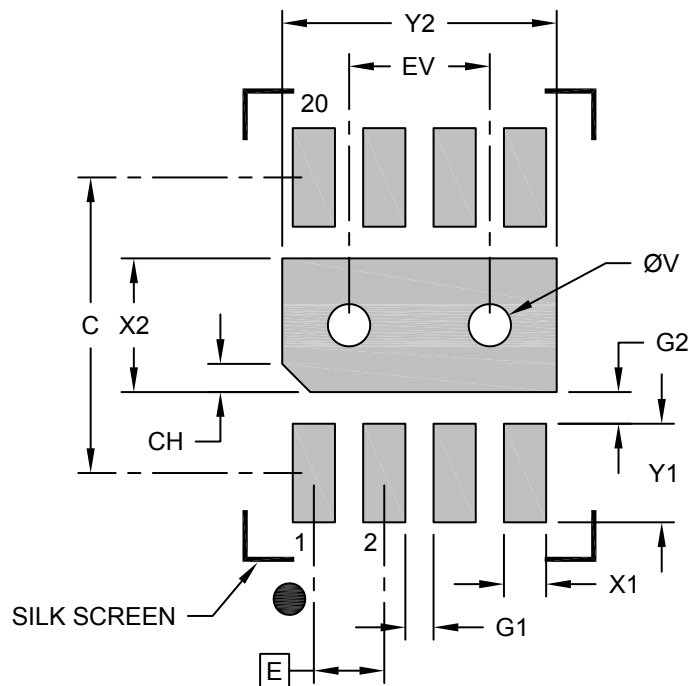

#### RECOMMENDED LAND PATTERN

Dimension Limits	Units	MILLIMETERS		
		MIN	NOM	MAX
Contact Pitch	E	0.50 BSC		
Optional Center Pad Width	X2			0.95
Optional Center Pad Length	Y2			1.95
Contact Pad Spacing	C		2.10	
Contact Pad Width (X8)	X1			0.30
Contact Pad Length (X8)	Y1			0.70
Contact Pad to Pad (X6)	G1	0.20		
Contact Pad to Center Pad (X8)	G2	0.23		
Thermal Via Diameter	V		0.30	
Thermal Via Pitch	EV		1.00	

**Notes:**

1. Dimensioning and tolerancing per ASME Y14.5M  
BSC: Basic Dimension. Theoretically exact value shown without tolerances.
2. For best soldering results, thermal vias, if used, should be filled or tented to avoid solder loss during reflow process

**Package Outlines and Dimensions**

**8-Lead Very Thin Plastic Dual Flat, No Lead Package (8Q) - 2x3 mm Body [VDFN]**

**Note:** For the most current package drawings, please see the Microchip Packaging Specification located at <http://www.microchip.com/packaging>

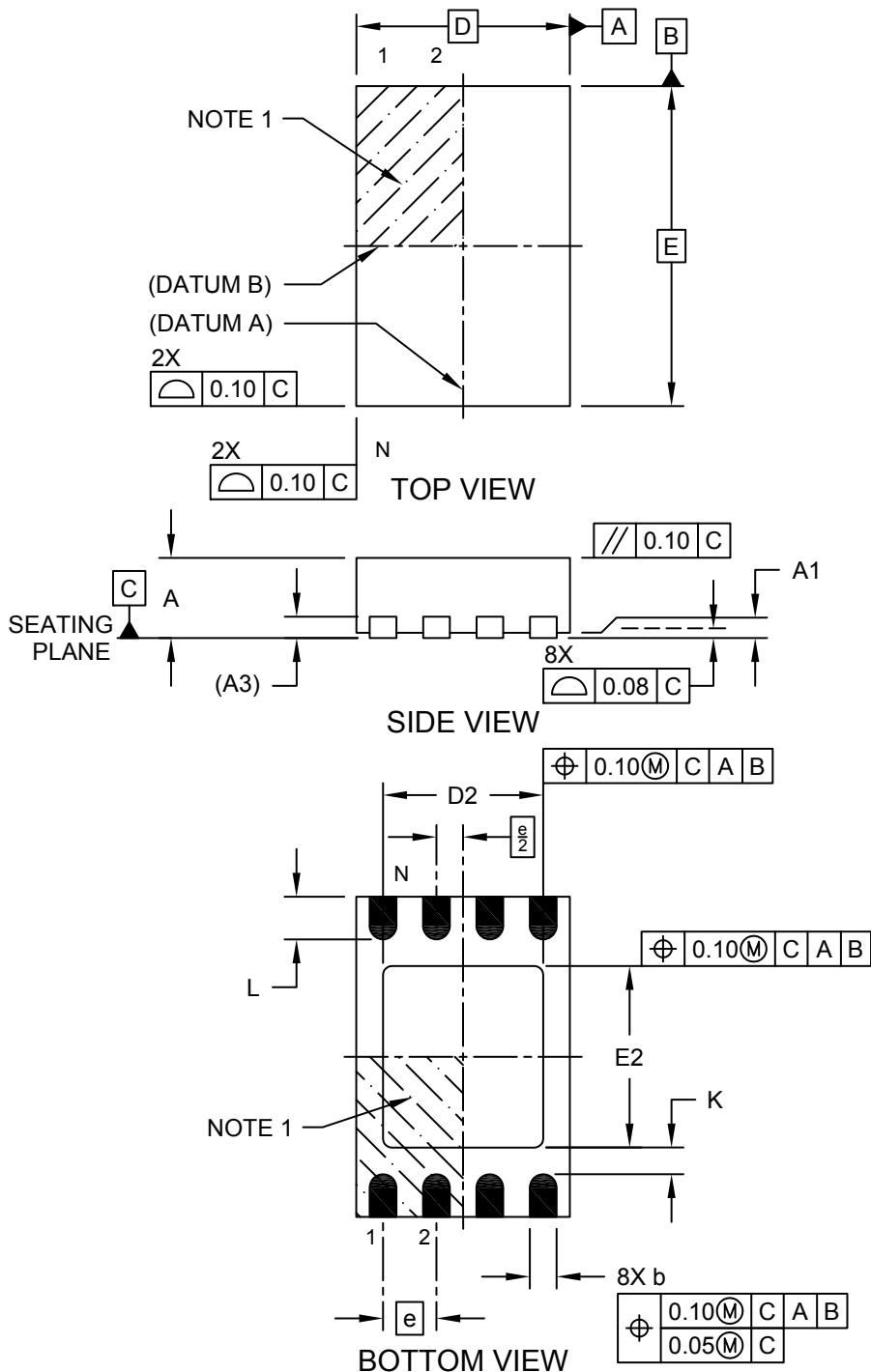

---



---

## Package Outlines and Dimensions

---



---

### 8-Lead Very Thin Plastic Dual Flat, No Lead Package (8Q) - 2x3 mm Body [VDFN]

**Note:** For the most current package drawings, please see the Microchip Packaging Specification located at <http://www.microchip.com/packaging>

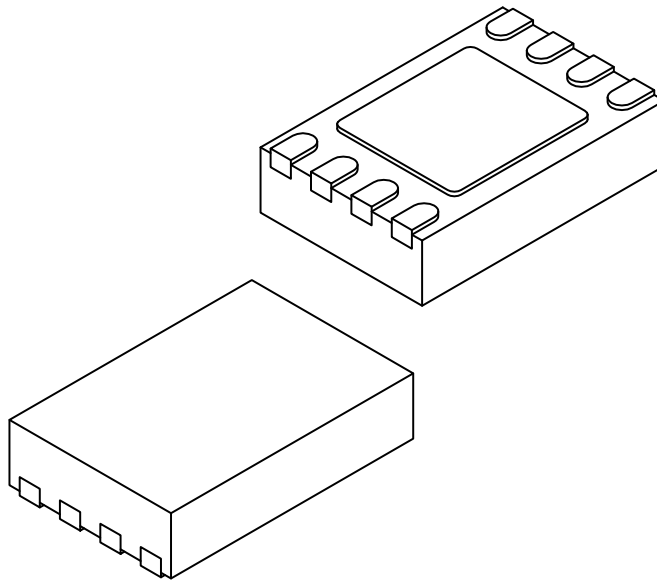

Dimension Limits	Units	MILLIMETERS		
		MIN	NOM	MAX
Number of Terminals	N	8		
Pitch	e	0.50 BSC		
Overall Height	A	0.70	0.75	0.80
Standoff	A1	0.00	0.02	0.05
Terminal Thickness	(A3)	0.20 REF		
Overall Length	D	2.00 BSC		
Exposed Pad Length	D2	1.40	1.50	1.60
Overall Width	E	3.00 BSC		
Exposed Pad Width	E2	1.60	1.70	1.80
Terminal Width	b	0.18	0.25	0.30
Terminal Length	L	0.35	0.40	0.45
Terminal-to-Exposed-Pad	K	0.20	-	-

**Notes:**

1. Pin 1 visual index feature may vary, but must be located within the hatched area.
2. Package is saw singulated
3. Dimensioning and tolerancing per ASME Y14.5M
  - BSC: Basic Dimension. Theoretically exact value shown without tolerances.
  - REF: Reference Dimension, usually without tolerance, for information purposes only.

**Footprint Outlines and Dimensions**

**8-Lead Very Thin Plastic Dual Flat, No Lead Package (8Q) - 2x3 mm Body [VDFN]**

**Note:** For the most current package drawings, please see the Microchip Packaging Specification located at <http://www.microchip.com/packaging>

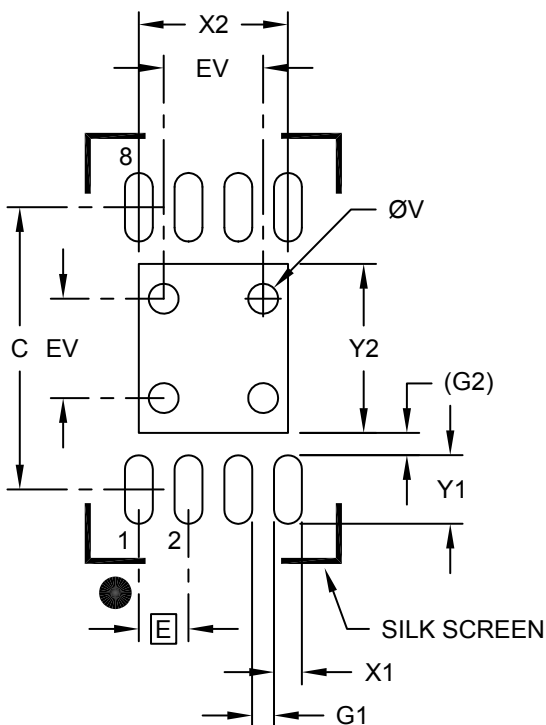

**RECOMMENDED LAND PATTERN**

Dimension Limits	Units	MILLIMETERS		
		MIN	NOM	MAX
Contact Pitch	E	0.50 BSC		
Optional Center Pad Width	X2			1.50
Optional Center Pad Length	Y2			1.70
Contact Pad Spacing	C	2.84		
Contact Pad Width (X8)	X1			0.28
Contact Pad Length (X8)	Y1			0.69
Space Between Pads	G1	0.20		
Contact Pad to Center Pad (X8)	(G2)	0.225 REF		
Thermal Via Diameter	V		0.30	
Thermal Via Pitch	EV		1.00	

**Notes:**

1. Dimensioning and tolerancing per ASME Y14.5M  
BSC: Basic Dimension. Theoretically exact value shown without tolerances.
2. For best soldering results, thermal vias, if used, should be filled or tented to avoid solder loss during reflow process

**Package Outlines and Dimensions**

**8-Lead Very Thin Plastic Dual Flat, No Lead Package (JEA) - 3x2 mm Body [VDFN] With Dimpled Wetttable Flanks**

**Note:** For the most current package drawings, please see the Microchip Packaging Specification located at <http://www.microchip.com/packaging>

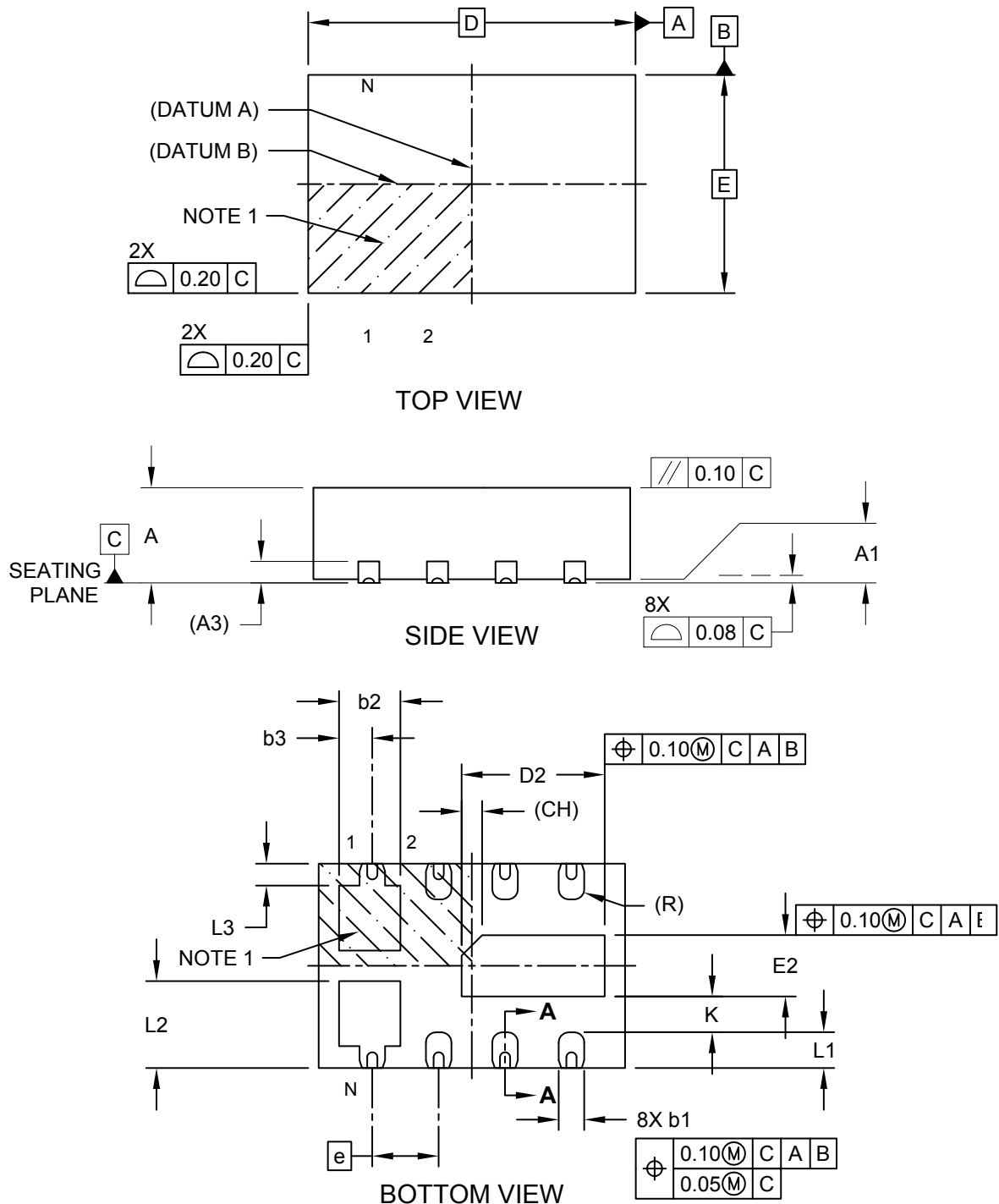

**Package Outlines and Dimensions**

**8-Lead Very Thin Plastic Dual Flat, No Lead Package (JEA) - 3x2 mm Body [VDFN]  
With Dimpled Wettable Flanks**

**Note:** For the most current package drawings, please see the Microchip Packaging Specification located at <http://www.microchip.com/packaging>

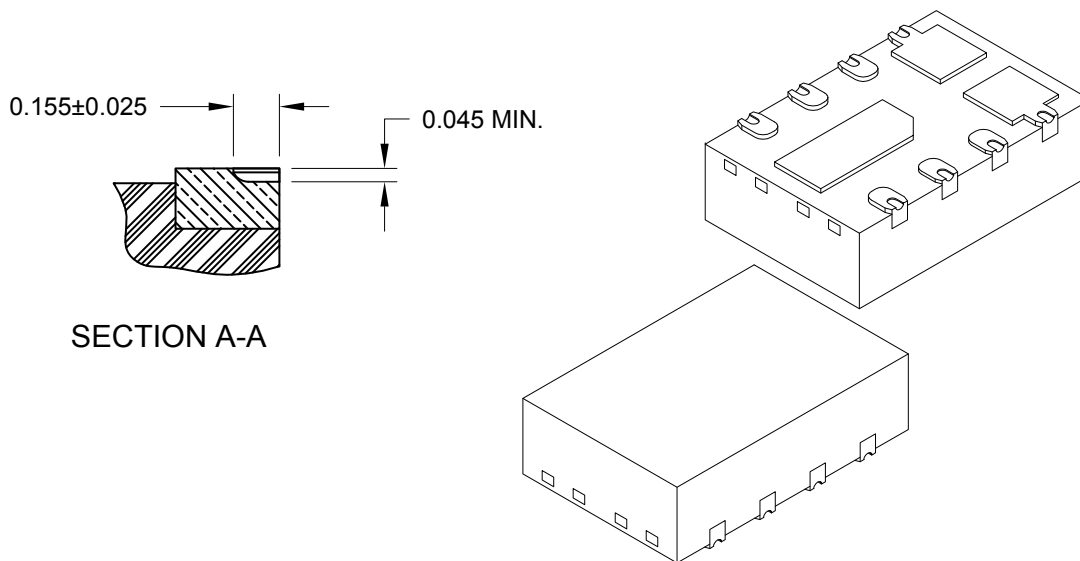

		MILLIMETERS		
Units		MIN	NOM	MAX
Dimension Limits		MIN	NOM	MAX
Number of Terminals	N	8		
Pitch	e	0.65 BSC		
Overall Height	A	0.80	0.85	0.90
Standoff	A1	0.00	0.02	0.05
Terminal Thickness	A3	0.20 REF		
Overall Length	D	3.00 BSC		
Exposed Pad Length	D2	0.50	0.60	0.70
Overall Width	E	2.00 BSC		
Exposed Pad Width	E2	1.30	1.40	1.50
Exposed Pad Chamfer	CH	0.20 REF		
Terminal Width	b1	0.18	0.25	0.30
Terminal Width	b2	-	-	0.60
Terminal Offset	b3	0.23	0.28	0.33
Terminal Length	L1	0.25	0.35	0.45
Terminal Length	L2	0.75	0.85	0.95
Terminal Length	L3	0.17	0.22	0.27
Terminal-to-Exposed-Pad	K	0.20	-	-
Terminal Radius	R	0.10 REF		

**Notes:**

1. Pin 1 visual index feature may vary, but must be located within the hatched area.
2. Package is saw singulated
3. Dimensioning and tolerancing per ASME Y14.5M

BSC: Basic Dimension. Theoretically exact value shown without tolerances.

REF: Reference Dimension, usually without tolerance, for information purposes only.



---



---

## Package Outlines and Dimensions

---



---

### 8-Lead Very Thin Plastic Dual Flat, No Lead Package (JEA) - 3x2 mm Body [VDFN] With Dimpled Wettable Flanks

**Note:** For the most current package drawings, please see the Microchip Packaging Specification located at <http://www.microchip.com/packaging>

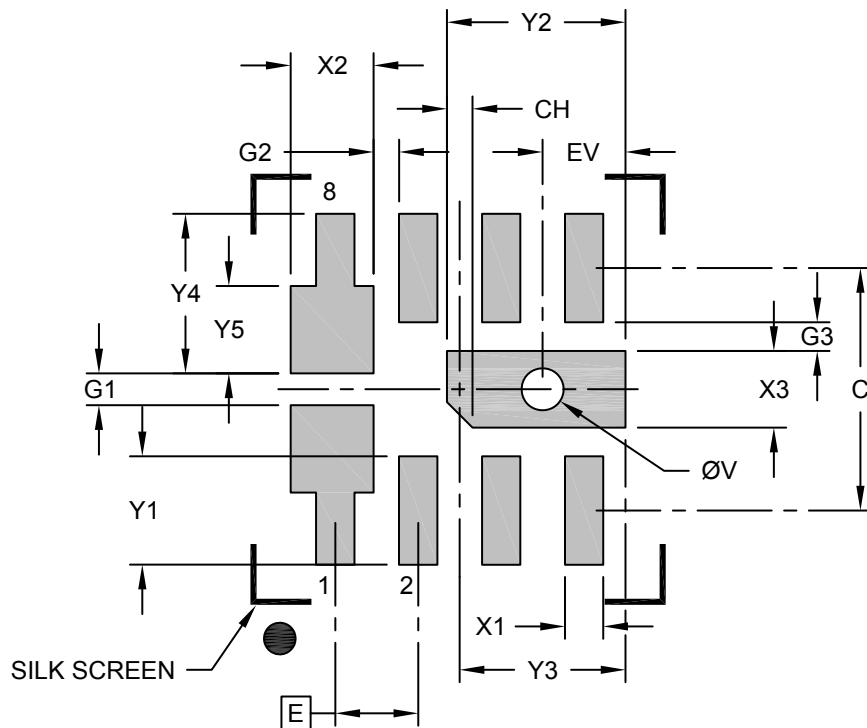

RECOMMENDED LAND PATTERN

	Units	MILLIMETERS		
		MIN	NOM	MAX
Dimension Limits				
Contact Pitch	E	0.65 BSC		
Contact Pad Width (X8)	X1			0.30
Contact Pad Length (X6)	Y1			0.85
Contact Pad Width (X2)	X2			0.65
Contact Pad Length (X2)	Y4			1.25
Contact Pad Length (X2)	Y5			0.68
Center Pad Width	X3			0.60
Center Pad Length	Y2			1.40
Center Pad Offset	Y3		1.30	
Center Pad Chamfer	CH		0.20	
Contact Pad Spacing	C		1.90	
Terminal Pad to Terminal Pad	G1	0.25		
Terminal Pad to Terminal Pad	G2	0.20		
Terminal Pad to Center Pad	G3	0.23		
Thermal Via Diameter	V		0.33	
Thermal Via Offset	EV		0.65	

1. Dimensioning and tolerancing per ASME Y14.5M  
BSC: Basic Dimension. Theoretically exact value shown without tolerances.
2. For best soldering results, thermal vias, if used, should be filled or tented to avoid solder loss during reflow process

**Package Outlines and Dimensions**

**8-Lead Very Thin Plastic Dual Flat, No Lead (9U) - 6x5 mm Body [VDFN]  
With Dual Exposed Pads**

**Note:** For the most current package drawings, please see the Microchip Packaging Specification located at <http://www.microchip.com/packaging>

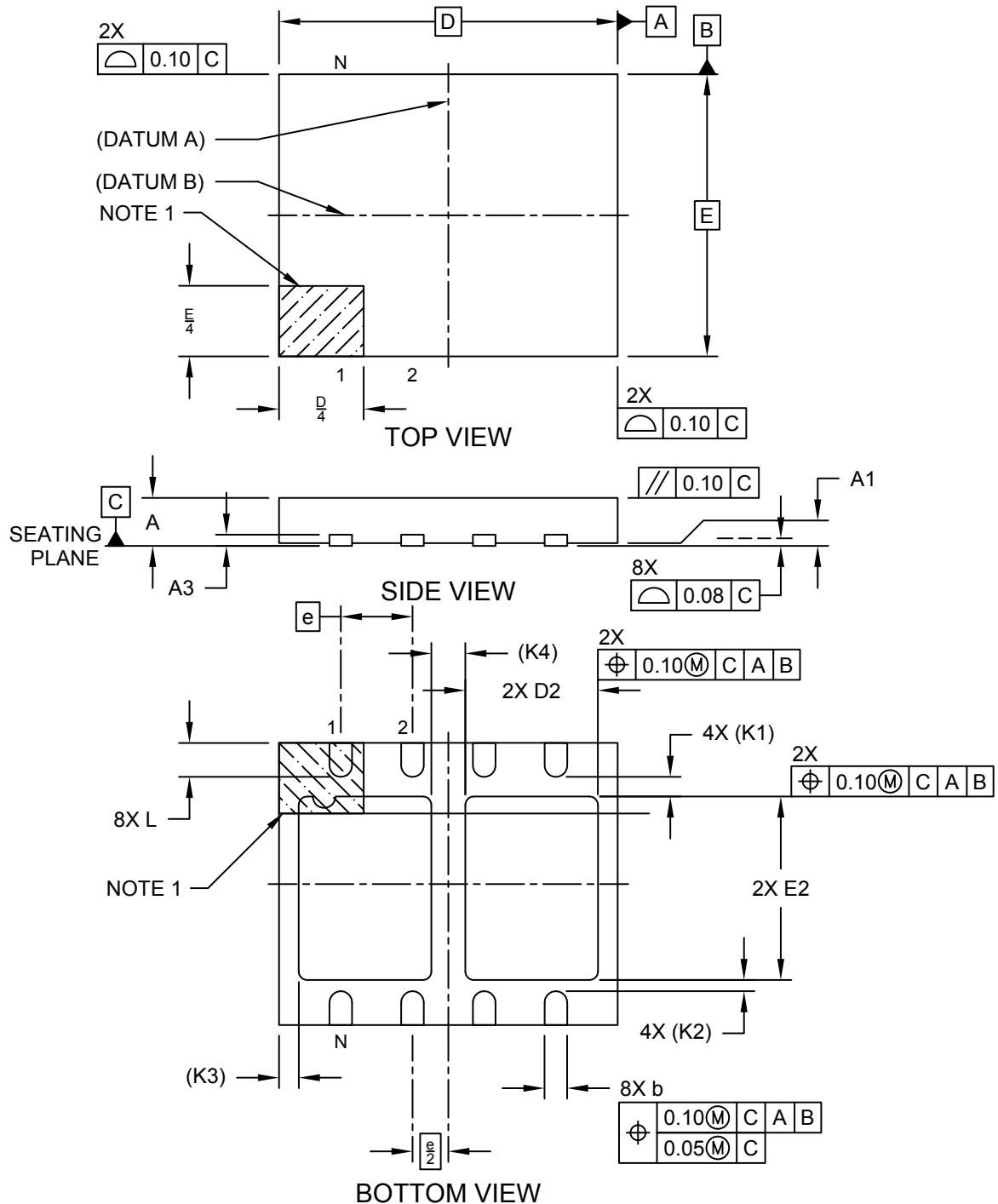

---



---

## Package Outlines and Dimensions

---



---

### 8-Lead Very Thin Plastic Dual Flat, No Lead (9U) - 6x5 mm Body [VDFN] With Dual Exposed Pads

**Note:** For the most current package drawings, please see the Microchip Packaging Specification located at <http://www.microchip.com/packaging>

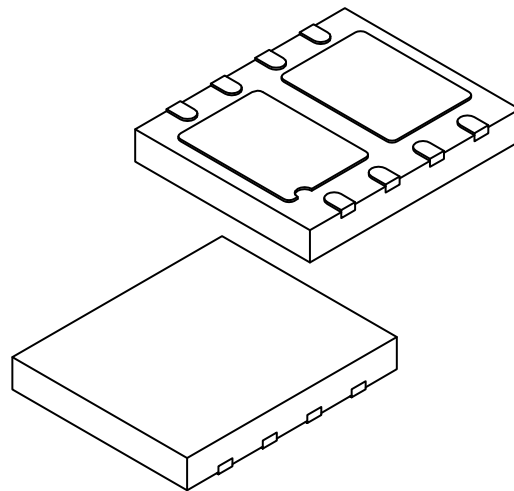

Dimension Limits	Units	MILLIMETERS		
		MIN	NOM	MAX
Number of Terminals	N	8		
Pitch	e	1.27 BSC		
Overall Height	A	0.80	0.85	0.90
Standoff	A1	0.00	0.02	0.05
Terminal Thickness	A3	0.20 REF		
Overall Length	D	6.00 BSC		
Exposed Pad Length (X2)	D2	2.25	2.35	2.45
Overall Width	E	5.00 BSC		
Exposed Pad Width (X2)	E2	3.15	3.25	3.35
Terminal Width	b	0.35	0.40	0.45
Terminal Length	L	0.55	0.60	0.65
Terminal to Exposed Pad (X4)	K1	0.35 REF		
Terminal to Exposed Pad (X4)	K2	0.20 REF		
Molded Package Edge to Exposed Pad	K3	0.35 REF		
Exposed Pad to Exposed Pad	K4	0.60 REF		

**Notes:**

1. Pin 1 visual index feature may vary, but must be located within the hatched area.
2. Package is saw singulated
3. Dimensioning and tolerancing per ASME Y14.5M
  - BSC: Basic Dimension. Theoretically exact value shown without tolerances.
  - REF: Reference Dimension, usually without tolerance, for information purposes only.

**Footprint Outlines and Dimensions**

**8-Lead Very Thin Plastic Dual Flat, No Lead (9U) - 6x5 mm Body [VDFN]  
With Dual Exposed Pads**

**Note:** For the most current package drawings, please see the Microchip Packaging Specification located at <http://www.microchip.com/packaging>

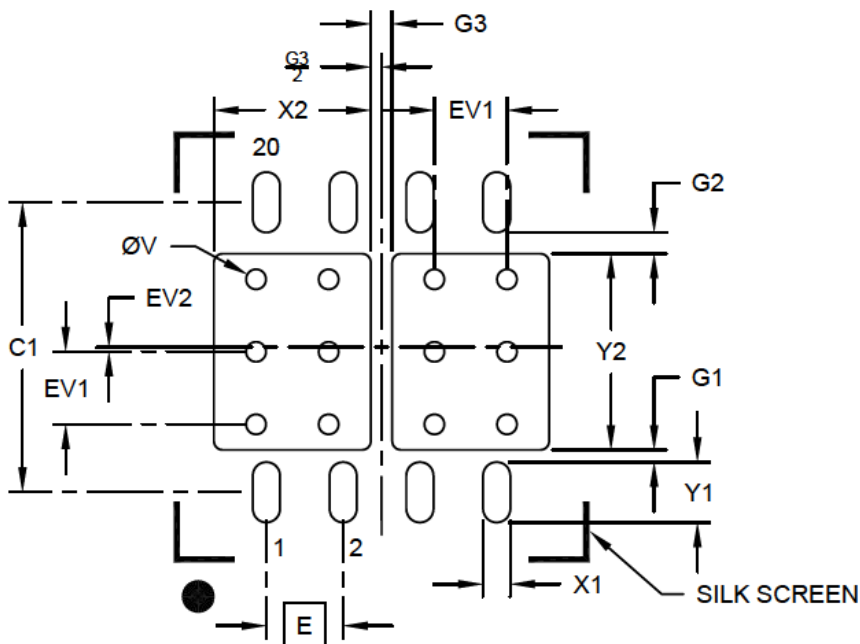

**RECOMMENDED LAND PATTERN**

Dimension Limits	Units	MILLIMETERS		
		MIN	NOM	MAX
Contact Pitch	E	1.27 BSC		
Optional Center Pad Width (X2)	X2			2.60
Optional Center Pad Length	Y2			3.25
Contact Pad Spacing	C1		4.80	
Contact Pad Width (X8)	X1			0.45
Contact Pad Length (X8)	Y1			0.80
Contact Pad to Center Pad (X4)	G1	0.20		
Contact Pad to Center Pad (X4)	G2	0.35		
Center Pad to Center Pad	G3		0.35	
Thermal Via Diameter (X12)	V		0.33	
Thermal Via Pitch	EV1		1.20	
Thermal Via Offset	EV2		0.08	

Notes:

- Dimensioning and tolerancing per ASME Y14.5M  
BSC: Basic Dimension. Theoretically exact value shown without tolerances.
- For best soldering results, thermal vias, if used, should be filled or tented to avoid solder loss during reflow process

**Package Outlines and Dimensions**

**10-Lead Very Thin Plastic Dual Flat, No Lead Package (9R) - 2.5x2.0 mm Body [VDFN]**

**Note:** For the most current package drawings, please see the Microchip Packaging Specification located at <http://www.microchip.com/packaging>

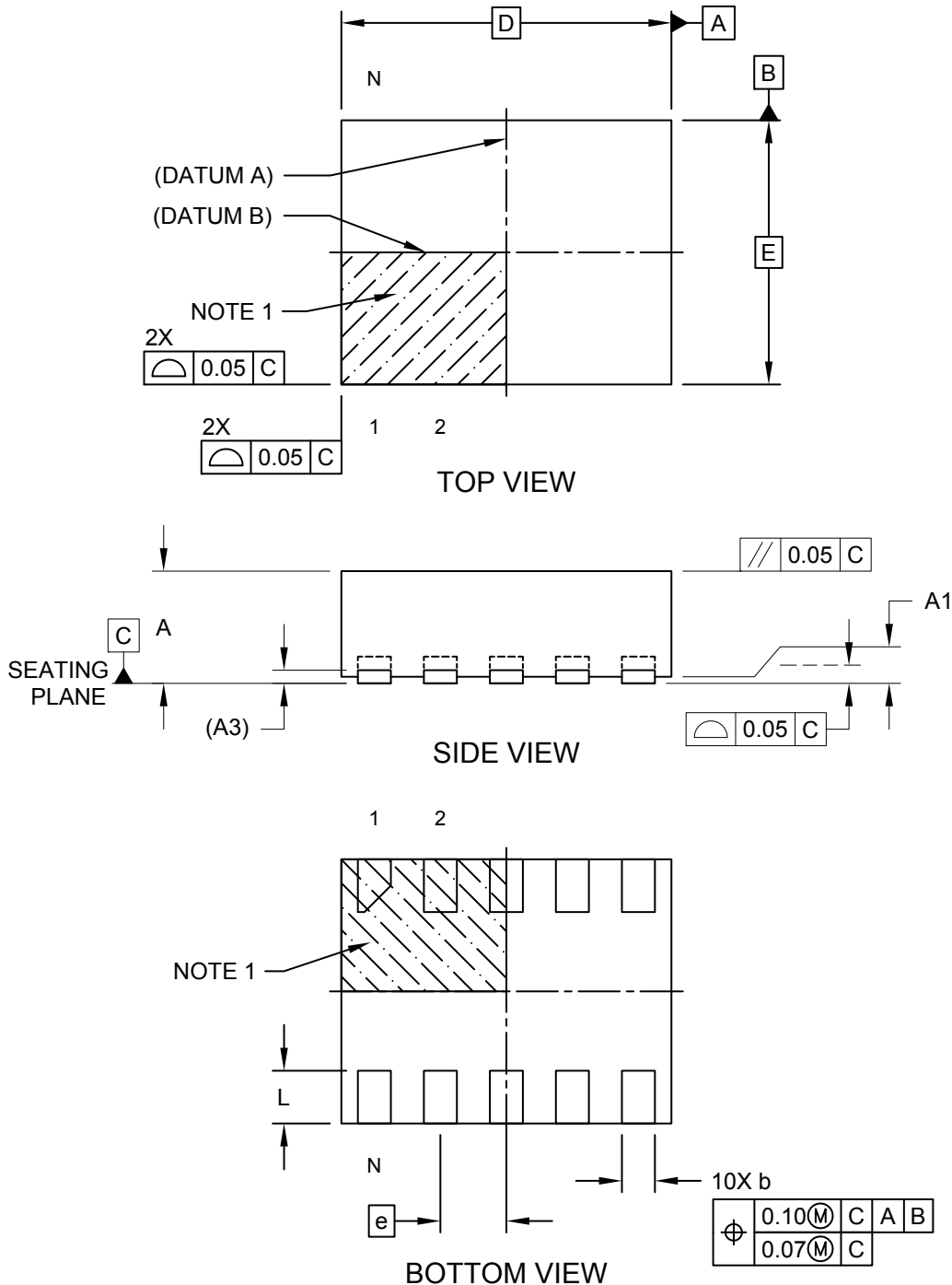

**Package Outlines and Dimensions**

**10-Lead Very Thin Plastic Dual Flat, No Lead Package (9R) - 2.5x2.0 mm Body [VDFN]**

**Note:** For the most current package drawings, please see the Microchip Packaging Specification located at <http://www.microchip.com/packaging>

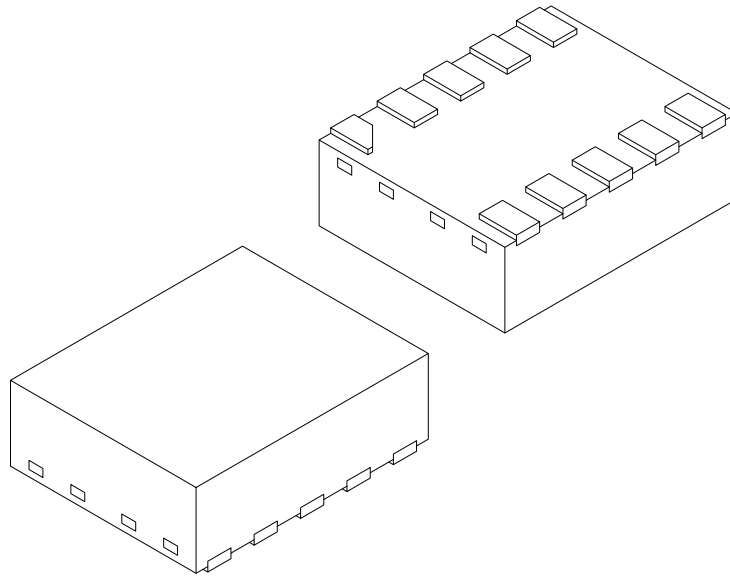

Dimension Limits	Units	MILLIMETERS		
		MIN	NOM	MAX
Number of Pins	N	10		
Pitch	e	0.50 BSC		
Overall Height	A	0.80	0.85	0.90
Standoff	A1	0.00	0.02	0.05
Terminal Thickness	(A3)	0.10 REF		
Overall Length	D	2.50 BSC		
Overall Width	E	2.00 BSC		
Terminal Width	b	0.20	0.25	0.30
Terminal Length	L	0.30	0.40	0.50

**Notes:**

1. Pin 1 visual index feature may vary, but must be located within the hatched area.
2. Package is saw singulated
3. Dimensioning and tolerancing per ASME Y14.5M

BSC: Basic Dimension. Theoretically exact value shown without tolerances.

REF: Reference Dimension, usually without tolerance, for information purposes only.

---



---

## Footprint Outlines and Dimensions

---



---

### 10-Lead Very Thin Plastic Dual Flat, No Lead Package (9R) - 2.5x2.0 mm Body [VDFN]

**Note:** For the most current package drawings, please see the Microchip Packaging Specification located at <http://www.microchip.com/packaging>

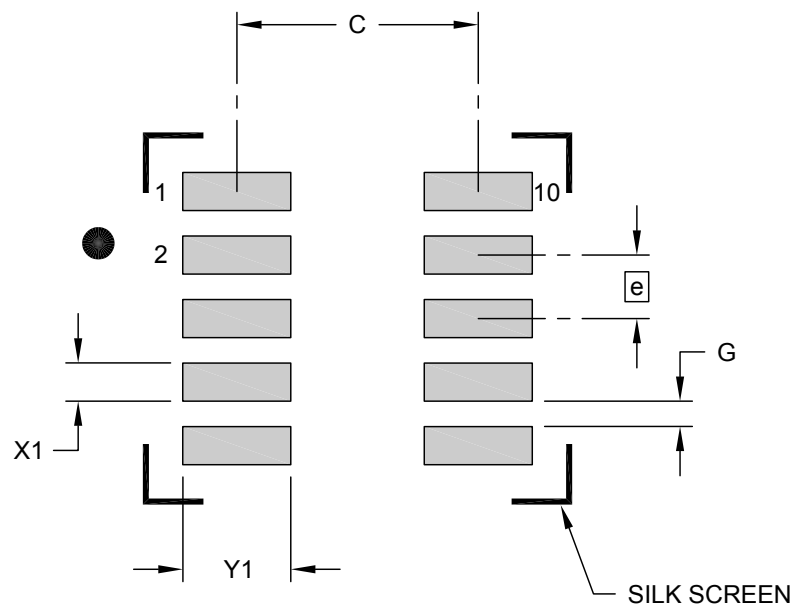

### RECOMMENDED LAND PATTERN

Dimension Limits	Units	MILLIMETERS		
		MIN	NOM	MAX
Contact Pitch	E	0.50 BSC		
Contact Pad Spacing	C		1.90	
Contact Pad Width (X10)	X1			0.30
Contact Pad Length (X10)	Y1			0.85
Contact Pad to Center Pad (X10)	G1	0.20		

**Notes:**

1. Dimensioning and tolerancing per ASME Y14.5M

BSC: Basic Dimension. Theoretically exact value shown without tolerances.

Microchip Technology Drawing C04-2332A

**Package Outlines and Dimensions**

**10-Lead Very Thin Plastic Dual Flat, No Lead Package (9Q) - 3x3 mm Body [VDFN]**

**Note:** For the most current package drawings, please see the Microchip Packaging Specification located at <http://www.microchip.com/packaging>

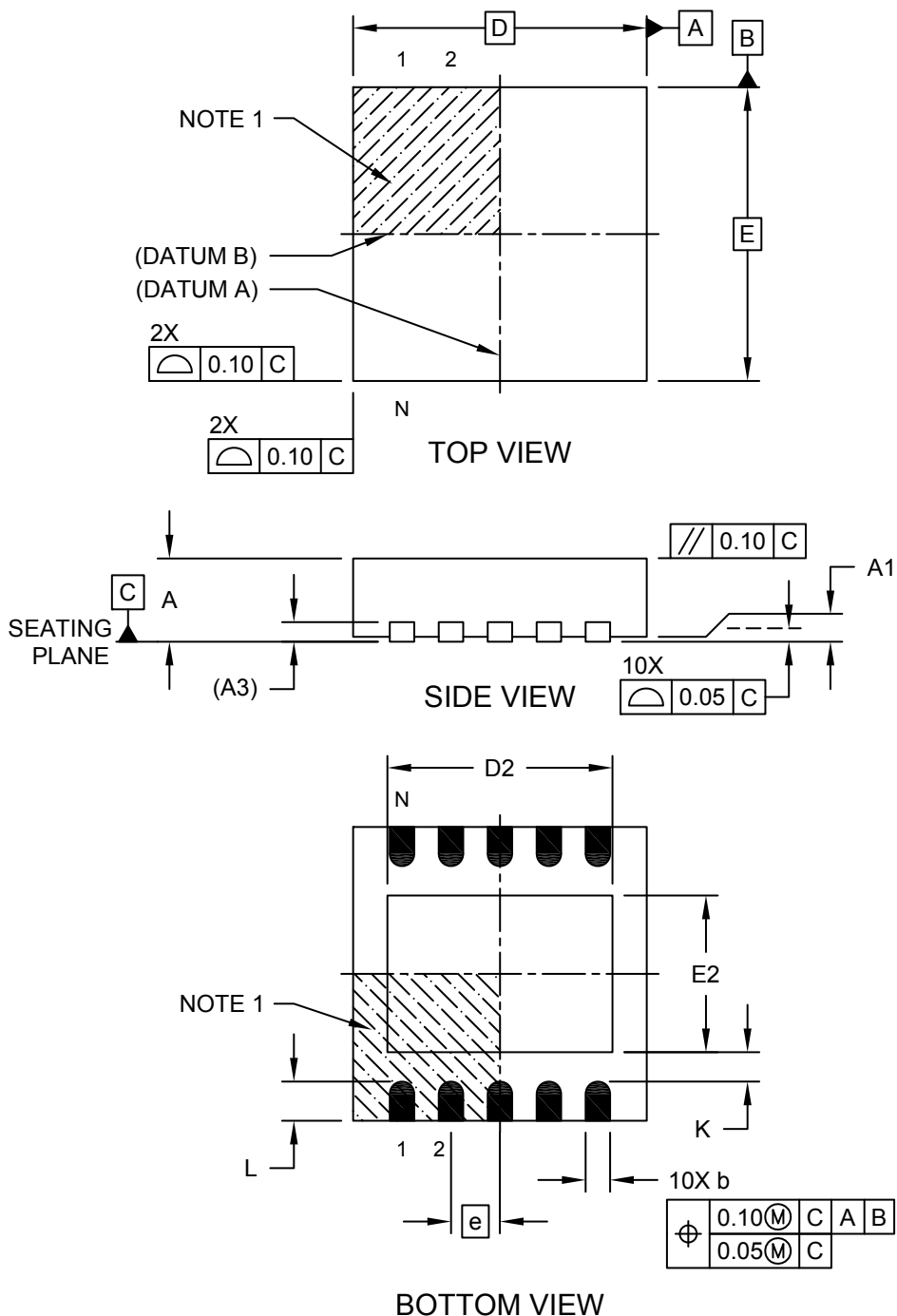



---



---

## Package Outlines and Dimensions

---



---

### 10-Lead Very Thin Plastic Dual Flat, No Lead Package (9Q) - 3x3 mm Body [VDFN]

**Note:** For the most current package drawings, please see the Microchip Packaging Specification located at <http://www.microchip.com/packaging>

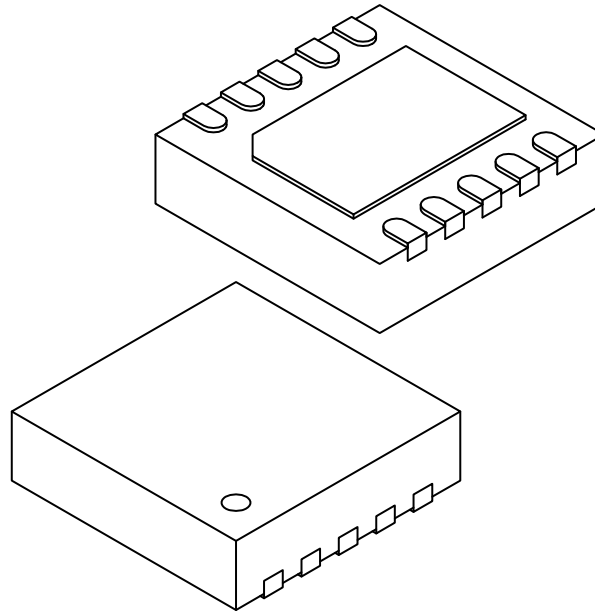

		Units	MILLIMETERS		
Dimension Limits			MIN	NOM	MAX
Number of Terminals	N		10		
Pitch	e		0.50 BSC		
Overall Height	A		0.80	0.85	0.90
Standoff	A1		0.00	0.02	0.05
Terminal Thickness	(A3)		0.20 REF		
Overall Length	D		3.00 BSC		
Exposed Pad Length	D2		2.20	2.30	2.40
Overall Width	E		3.00 BSC		
Exposed Pad Width	E2		1.50	1.60	1.70
Terminal Width	b		0.18	0.25	0.30
Terminal Length	L		0.35	0.40	0.45
Terminal-to-Exposed-Pad	K		0.25	0.30	-

**Notes:**

1. Pin 1 visual index feature may vary, but must be located within the hatched area.
2. Package is saw singulated
3. Dimensioning and tolerancing per ASME Y14.5M

BSC: Basic Dimension. Theoretically exact value shown without tolerances.

REF: Reference Dimension, usually without tolerance, for information purposes only.

**Footprint Outlines and Dimensions**

**10-Lead Very Thin Plastic Dual Flat, No Lead Package (9Q) - 3x3 mm Body [VDFN]**

**Note:** For the most current package drawings, please see the Microchip Packaging Specification located at <http://www.microchip.com/packaging>

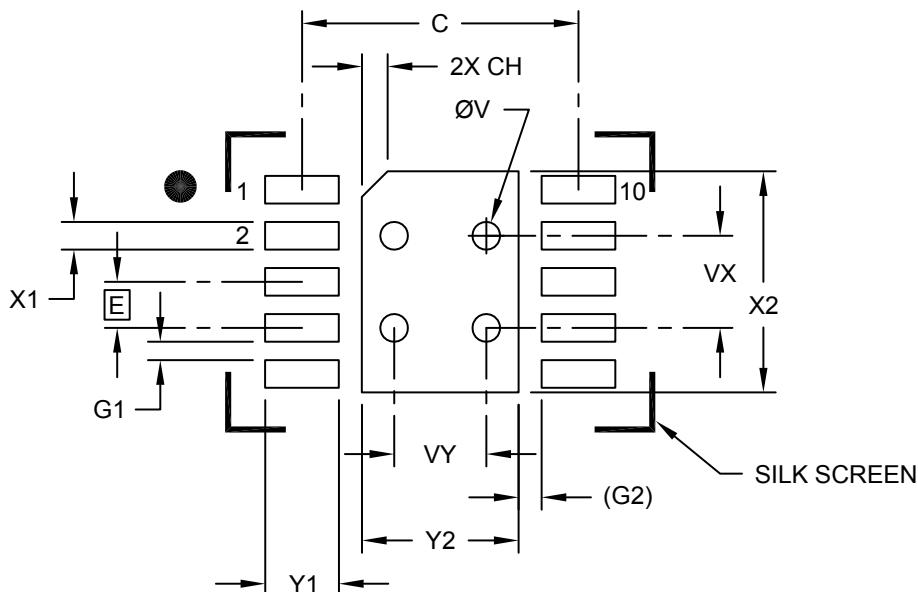

**RECOMMENDED LAND PATTERN**

Dimension Limits	Units	MILLIMETERS		
		MIN	NOM	MAX
Contact Pitch	E	0.50 BSC		
Optional Center Pad Width	Y2			1.70
Optional Center Pad Length	X2			2.40
Contact Pad Spacing	C		3.00	
Center Pad Chamfer	CH		0.28	
Contact Pad Width (X10)	X1			0.30
Contact Pad Length (X10)	Y1			0.80
Contact Pad to Contact Pad (X8)	G1	0.20		
Contact Pad to Center Pad (X10)	G2	0.25 REF		
Thermal Via Diameter	V		0.30	
Thermal Via Pitch	VX		1.00	
Thermal Via Pitch	VY		1.00	

**Notes:**

- Dimensioning and tolerancing per ASME Y14.5M  
 BSC: Basic Dimension. Theoretically exact value shown without tolerances.  
 REF: Reference Dimension, usually without tolerances, for reference only.
- For best soldering results, thermal vias, if used, should be filled or tented to avoid solder loss during reflow process

**Package Outlines and Dimensions**

**11-Lead Very Thin Plastic Dual Flat, No Lead Package (K4A) - 6x5 mm Body [VDFN]  
With Dual Fused Exposed Pads**

**Note:** For the most current package drawings, please see the Microchip Packaging Specification located at <http://www.microchip.com/packaging>

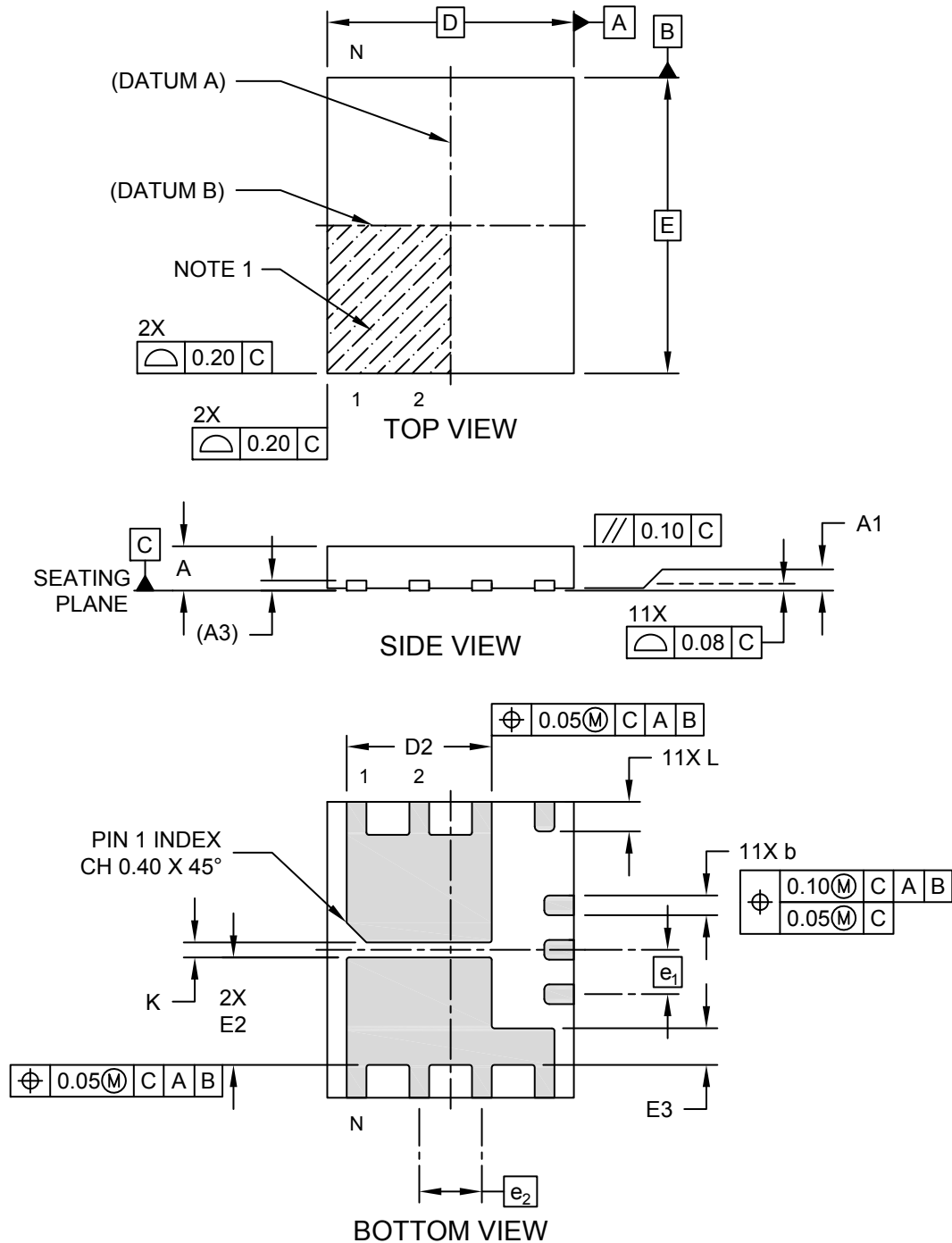

**Package Outlines and Dimensions**

**11-Lead Very Thin Plastic Dual Flat, No Lead Package (K4A) - 6x5 mm Body [VDFN]  
With Dual Fused Exposed Pads**

**Note:** For the most current package drawings, please see the Microchip Packaging Specification located at <http://www.microchip.com/packaging>

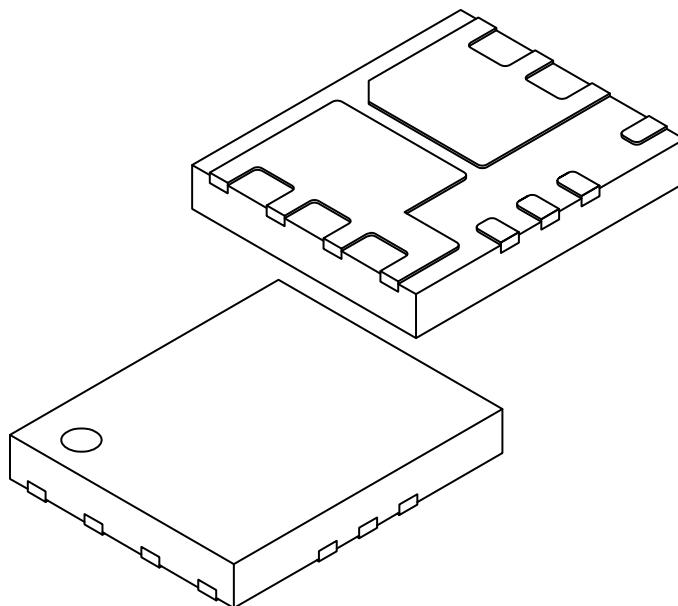

Dimension Limits	Units	MILLIMETERS		
		MIN	NOM	MAX
Number of Terminals	N	11		
Pitch	e <sub>1</sub>	0.90 BSC		
Pitch	e <sub>2</sub>	1.27 BSC		
Overall Height	A	0.80	0.85	0.90
Standoff	A1	0.00	0.02	0.05
Terminal Thickness	A3	0.203 REF		
Overall Length	D	5.00 BSC		
Exposed Pad Length	D2	2.89	2.94	2.99
Overall Width	E	6.00 BSC		
Exposed Pad Width	E2	2.13	2.18	2.23
Exposed Pad Width	E3	0.69	0.74	0.79
Terminal Width	b	0.35	0.40	0.50
Terminal Length	L	0.55	0.60	0.65
Spacing Between Exposed Pads	K	0.20	-	-

**Notes:**

1. Pin 1 visual index feature may vary, but must be located within the hatched area.
2. Package is saw singulated
3. Dimensioning and tolerancing per ASME Y14.5M

BSC: Basic Dimension. Theoretically exact value shown without tolerances.

REF: Reference Dimension, usually without tolerance, for information purposes only.

---



---

## Footprint Outlines and Dimensions

---



---

### 11-Lead Very Thin Plastic Dual Flat, No Lead Package (K4A) - 6x5 mm Body [VDFN] With Dual Fused Exposed Pads

**Note:** For the most current package drawings, please see the Microchip Packaging Specification located at <http://www.microchip.com/packaging>

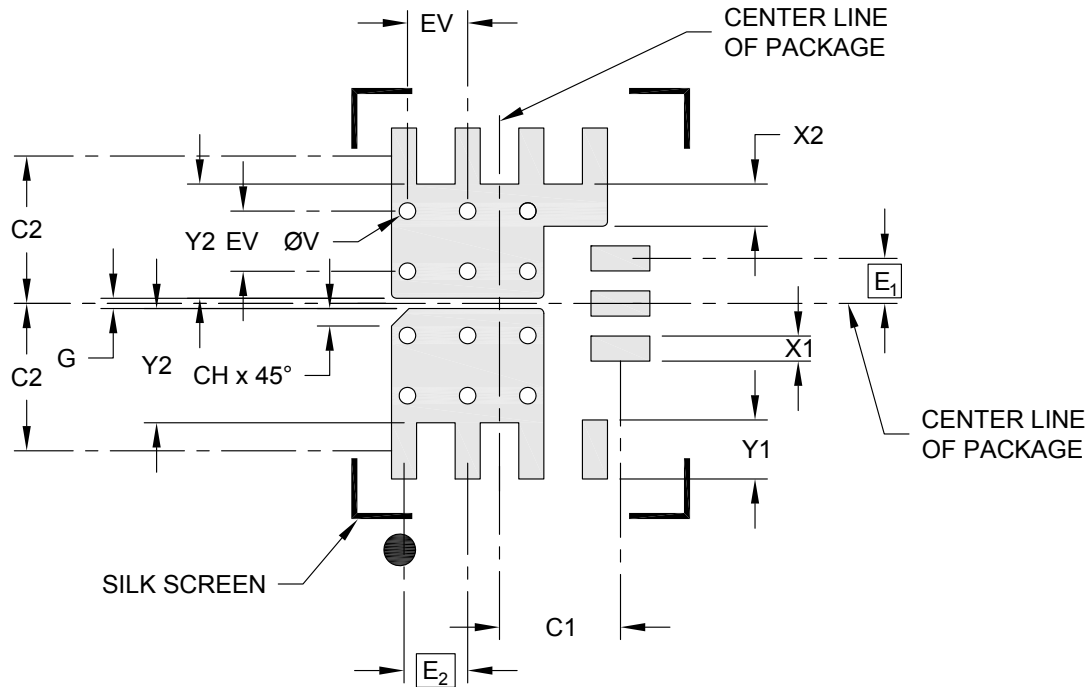

#### RECOMMENDED LAND PATTERN

Units		MILLIMETERS		
		MIN	NOM	MAX
Contact Pitch	E <sub>1</sub>	0.90 BSC		
Contact Pitch	E <sub>2</sub>	1.27 BSC		
Contact Pad Width (X11)	X1			0.50
Center Pad Width	X2			0.84
Contact Pad Length (X11)	Y1			0.80
Center Pad Length	Y2			2.28
Package Center to Contact Center	C1		2.41	
Package Center to Contact Center	C2		2.94	
Center Pad Chamfer	CH		0.35	
Spacing Between Exposed Pads	G	0.20		
Thermal Via Diameter	V		0.33	
Thermal Via Pitch	EV		1.20	

**Notes:**

1. Dimensioning and tolerancing per ASME Y14.5M  
BSC: Basic Dimension. Theoretically exact value shown without tolerances.
2. For best soldering results, thermal vias, if used, should be filled or tented to avoid solder loss during reflow process

**Package Outlines and Dimensions**

**14-Lead Very Thin Plastic Dual Flat, No Lead Package (4S) - 4.5x3.0 mm Body [VDFN]**

**Note:** For the most current package drawings, please see the Microchip Packaging Specification located at <http://www.microchip.com/packaging>

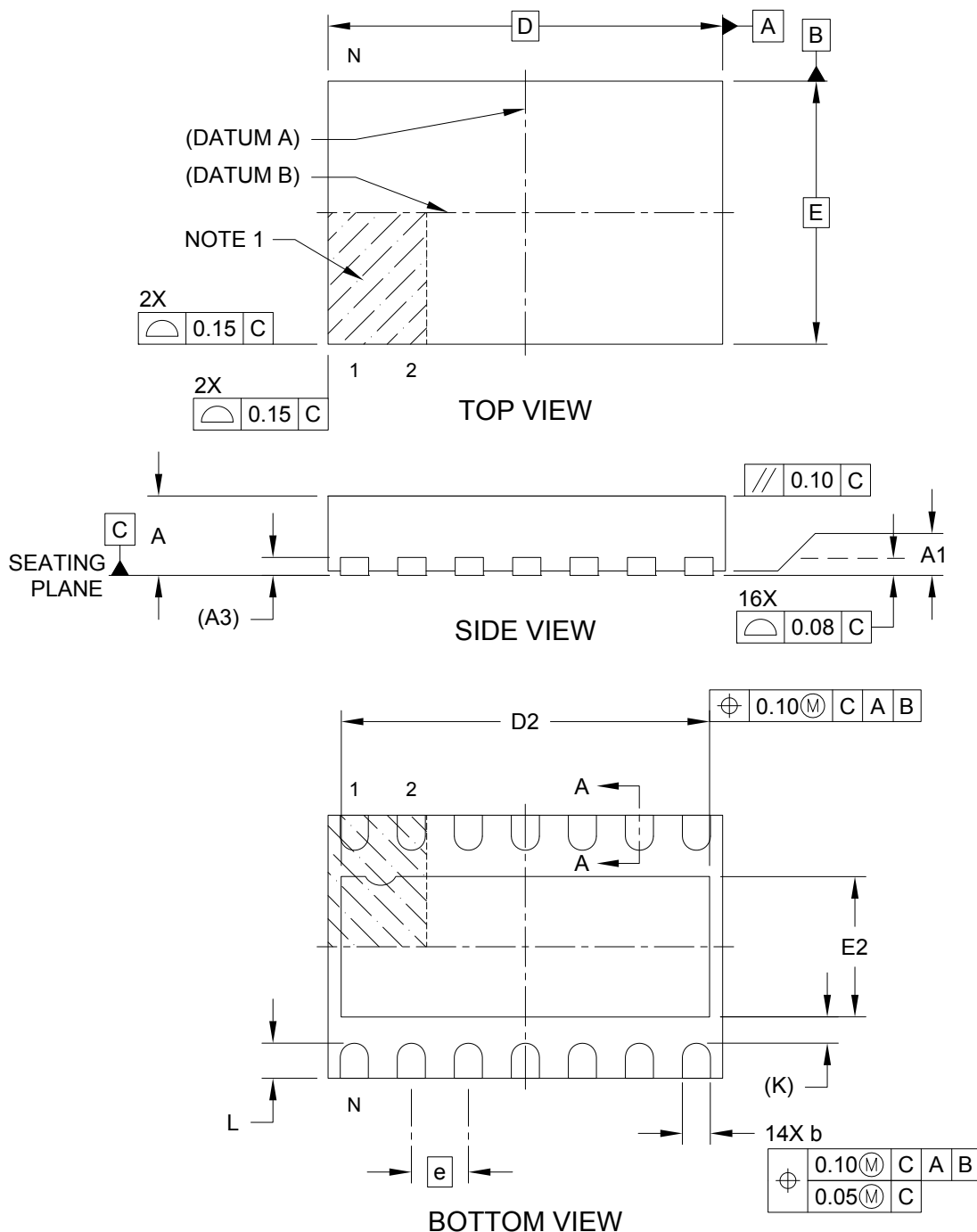

---



---

## Package Outlines and Dimensions

---



---

### 14-Lead Very Thin Plastic Dual Flat, No Lead Package (4S) - 4.5x3.0 mm Body [VDFN]

**Note:** For the most current package drawings, please see the Microchip Packaging Specification located at <http://www.microchip.com/packaging>

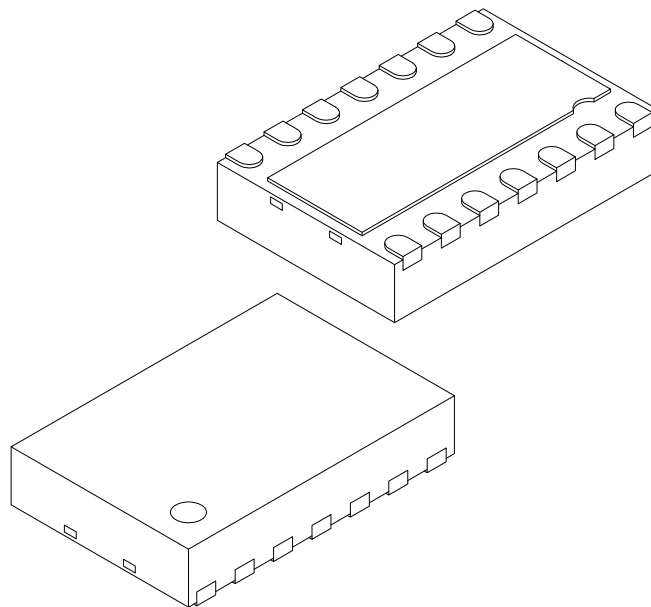

Dimension Limits		Units	MILLIMETERS		
			MIN	NOM	MAX
Number of Terminals	N		14		
Pitch	e		0.65 BSC		
Overall Height	A	0.80	0.85	0.90	
Standoff	A1	0.00	0.02	0.05	
Terminal Thickness	A3	0.203 REF			
Overall Length	D	4.50 BSC			
Exposed Pad Length	D2	4.15	4.20	4.25	
Overall Width	E	3.00 BSC			
Exposed Pad Width	E2	1.55	1.60	1.65	
Terminal Width	b	0.29	0.32	0.35	
Terminal Length	L	0.35	0.40	0.45	
Terminal-to-Exposed-Pad	K	0.30 REF			

**Notes:**

1. Pin 1 visual index feature may vary, but must be located within the hatched area.
2. Package is saw singulated
3. Dimensioning and tolerancing per ASME Y14.5M

BSC: Basic Dimension. Theoretically exact value shown without tolerances.

REF: Reference Dimension, usually without tolerance, for information purposes only.

**Footprint Outlines and Dimensions**

**14-Lead Very Thin Plastic Dual Flat, No Lead Package (4S) - 4.5x3.0 mm Body [VDFN]**

**Note:** For the most current package drawings, please see the Microchip Packaging Specification located at <http://www.microchip.com/packaging>

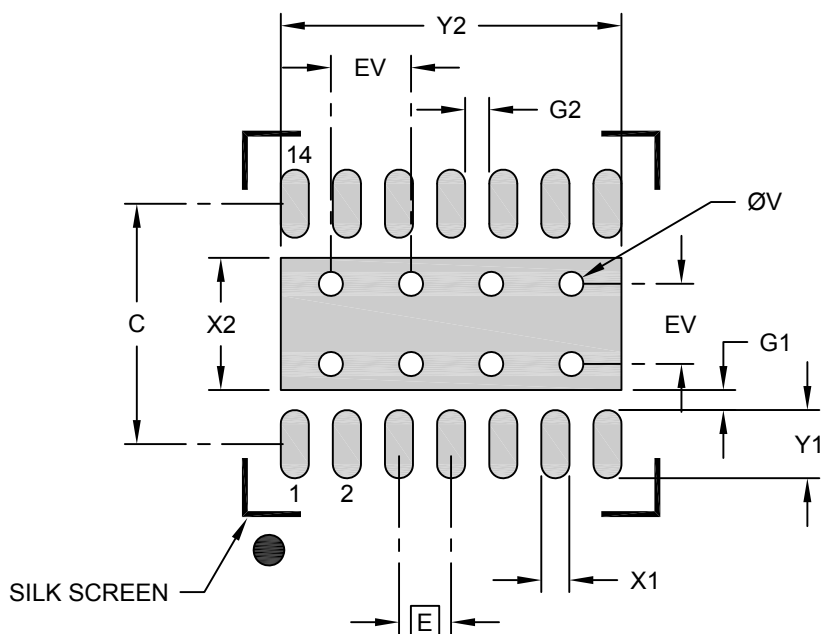

**RECOMMENDED LAND PATTERN**

Dimension Limits	Units	MILLIMETERS		
		MIN	NOM	MAX
Contact Pitch	E	0.65 BSC		
Optional Center Pad Width	X2			1.65
Optional Center Pad Length	Y2			4.25
Contact Pad Spacing	C		3.00	
Contact Pad Width (X14)	X1			0.35
Contact Pad Length (X14)	Y1			0.85
Contact Pad to Center Pad (X14)	G1	0.25		
Spacing Between Contacts (X12)	G1	0.30		
Thermal Via Diameter	V		0.30	
Thermal Via Pitch	EV		1.00	

**Notes:**

1. Dimensioning and tolerancing per ASME Y14.5M  
BSC: Basic Dimension. Theoretically exact value shown without tolerances.
2. For best soldering results, thermal vias, if used, should be filled or tented to avoid solder loss during reflow process



**Package Outlines and Dimensions**

**14-Lead Very Thin Plastic Quad Flat, No Lead Package (JHA) - 4.5x3.0 mm Body [VDFN] With Dimpled Wetable Flanks**

**Note:** For the most current package drawings, please see the Microchip Packaging Specification located at <http://www.microchip.com/packaging>

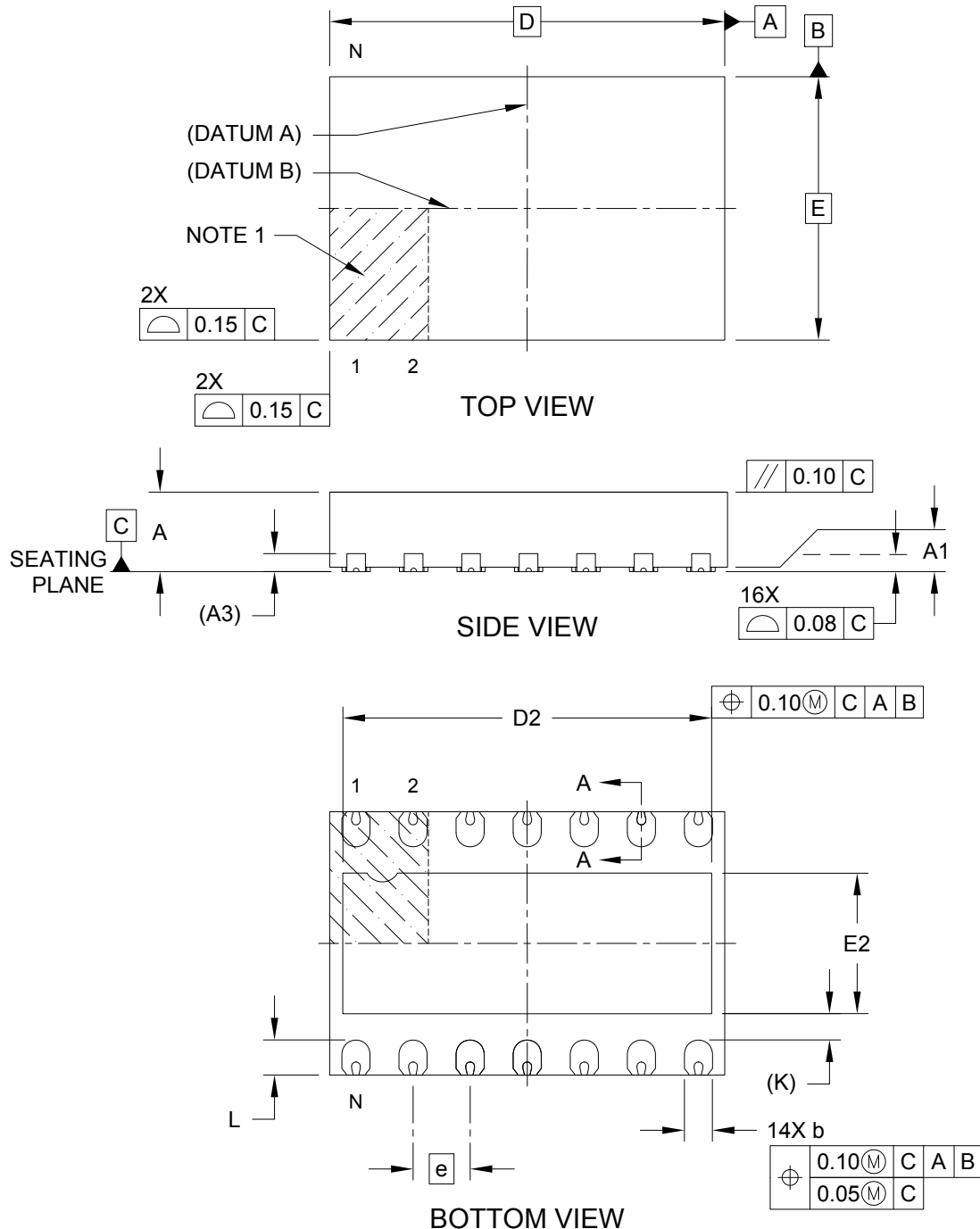

**Package Outlines and Dimensions**

**14-Lead Very Thin Plastic Quad Flat, No Lead Package (JHA) - 4.5x3.0 mm Body [VDFN] With Dimpled Wettable Flanks**

**Note:** For the most current package drawings, please see the Microchip Packaging Specification located at <http://www.microchip.com/packaging>

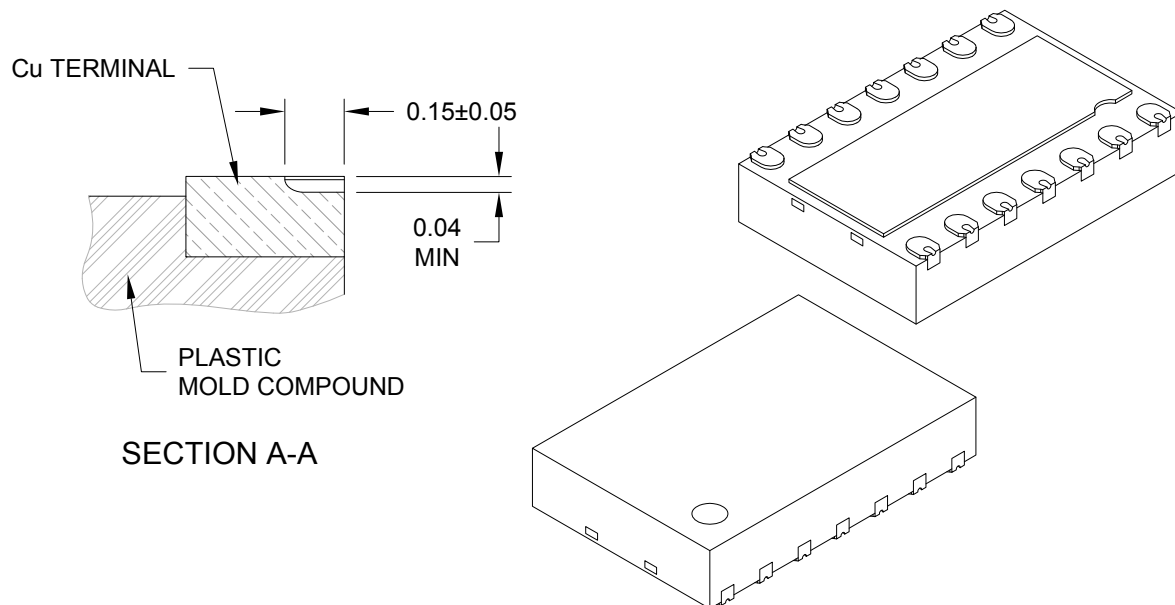

Dimension Limits	Units	MILLIMETERS		
		MIN	NOM	MAX
Number of Terminals	N	14		
Pitch	e	0.65 BSC		
Overall Height	A	0.80	0.85	0.90
Standoff	A1	0.00	0.02	0.05
Terminal Thickness	A3	0.203 REF		
Overall Length	D	4.50 BSC		
Exposed Pad Length	D2	4.15	4.20	4.25
Overall Width	E	3.00 BSC		
Exposed Pad Width	E2	1.55	1.60	1.65
Terminal Width	b	0.29	0.32	0.35
Terminal Length	L	0.35	0.40	0.45
Terminal-to-Exposed-Pad	K	0.30 REF		

**Notes:**

- Pin 1 visual index feature may vary, but must be located within the hatched area.
- Package is saw singulated
- Dimensioning and tolerancing per ASME Y14.5M
  - BSC: Basic Dimension. Theoretically exact value shown without tolerances.
  - REF: Reference Dimension, usually without tolerance, for information purposes only.

---



---

## Footprint Outlines and Dimensions

---



---

### 14-Lead Very Thin Plastic Quad Flat, No Lead Package (JHA) - 4.5x3.0 mm Body [VDFN] With Dimpled Wettable Flanks

**Note:** For the most current package drawings, please see the Microchip Packaging Specification located at <http://www.microchip.com/packaging>

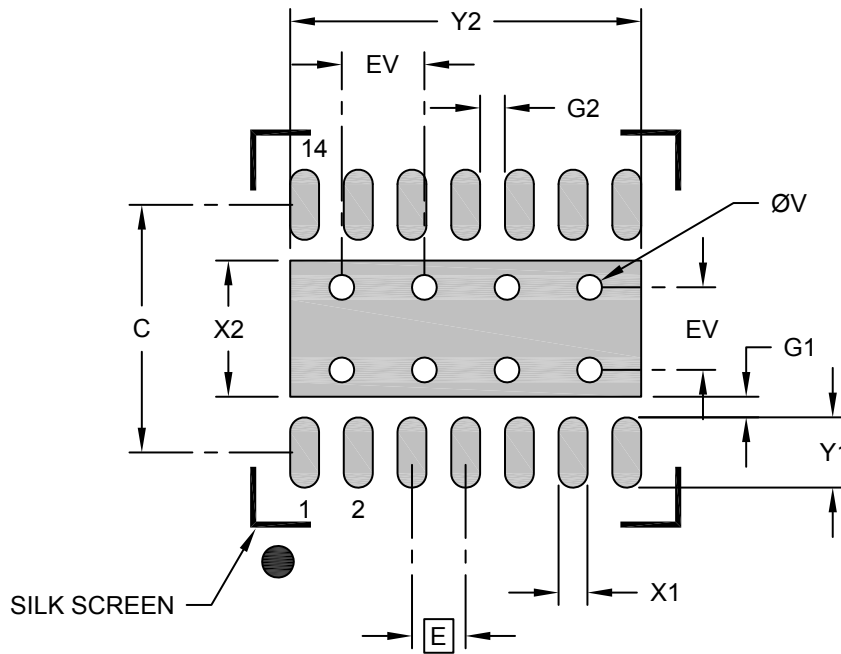

**RECOMMENDED LAND PATTERN**

Dimension Limits	Units	MILLIMETERS		
		MIN	NOM	MAX
Contact Pitch	E	0.65 BSC		
Optional Center Pad Width	X2			1.65
Optional Center Pad Length	Y2			4.25
Contact Pad Spacing	C		3.00	
Contact Pad Width (X14)	X1			0.35
Contact Pad Length (X14)	Y1			0.85
Contact Pad to Center Pad (X14)	G1	0.25		
Spacing Between Contacts (X12)	G1	0.30		
Thermal Via Diameter	V		0.30	
Thermal Via Pitch	EV		1.00	

**Notes:**

1. Dimensioning and tolerancing per ASME Y14.5M  
BSC: Basic Dimension. Theoretically exact value shown without tolerances.
2. For best soldering results, thermal vias, if used, should be filled or tented to avoid solder loss during reflow process



**MICROCHIP**

---

---

**Package Outlines and Dimensions**

---

---

**NOTES:**

---

---

**Package Outlines and Dimensions**

---

---

**WDFN**

**Package Outlines and Dimensions**

**8-Lead Very, Very Thin Plastic Dual Flat, No Lead Package (RW) - 2x2 mm Body [WDFN]**

**Note:** For the most current package drawings, please see the Microchip Packaging Specification located at <http://www.microchip.com/packaging>

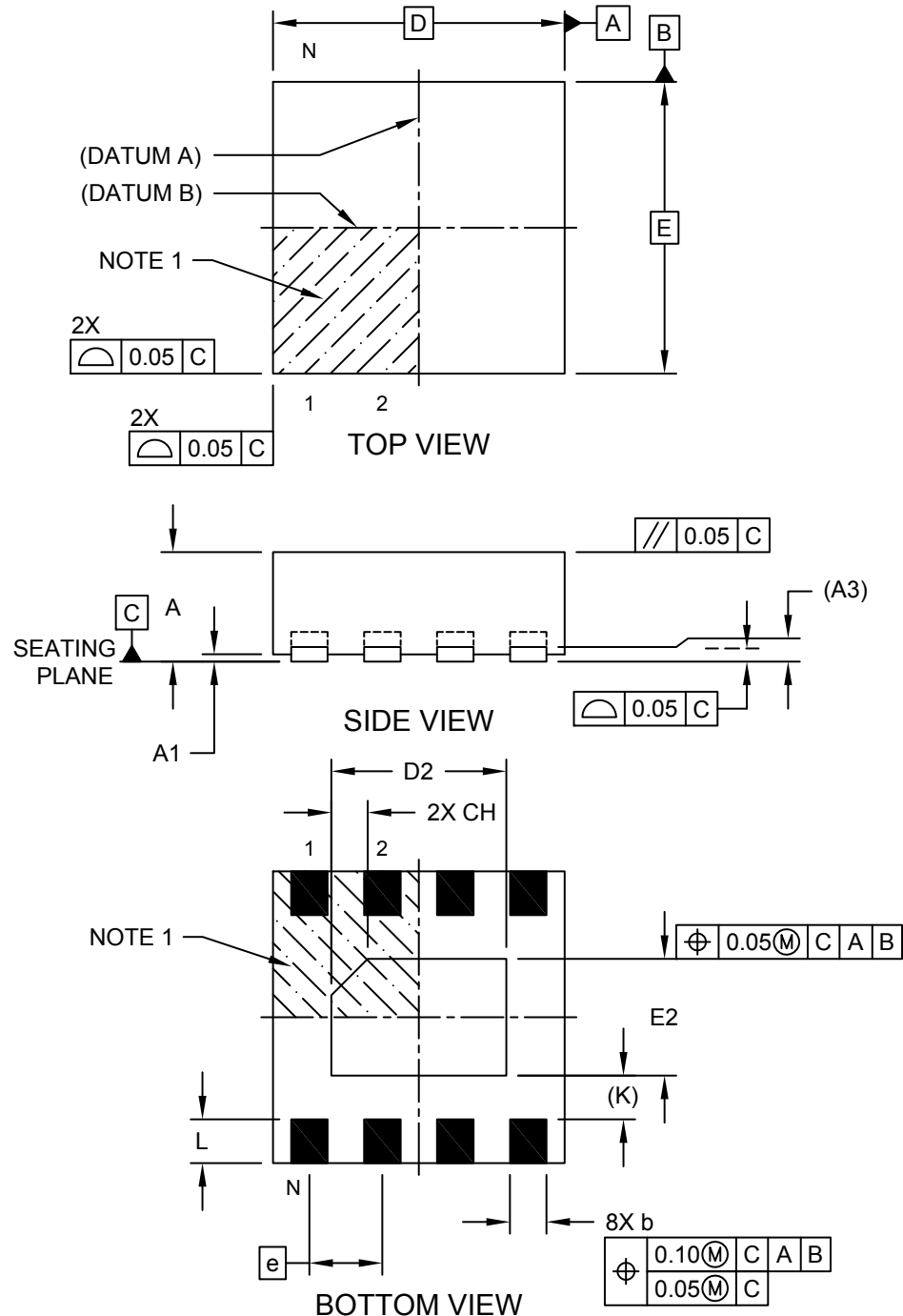

---



---

## Package Outlines and Dimensions

---



---

### 8-Lead Very, Very Thin Plastic Dual Flat, No Lead Package (RW) - 2x2 mm Body [WDFN]

**Note:** For the most current package drawings, please see the Microchip Packaging Specification located at <http://www.microchip.com/packaging>

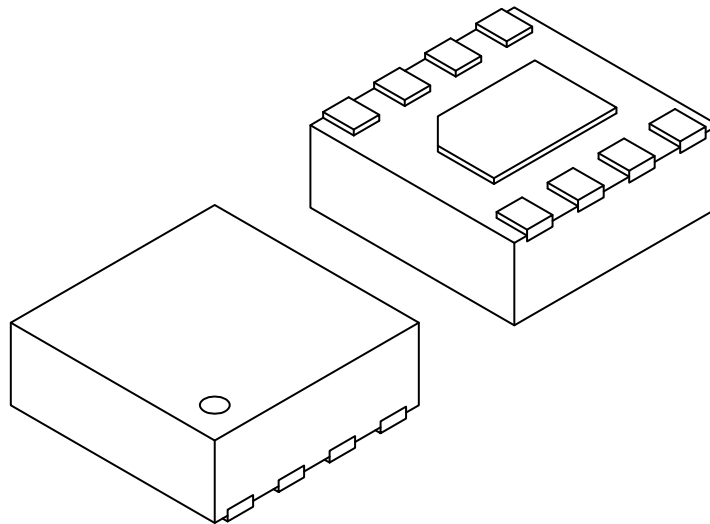

Dimension Limits		MILLIMETERS		
		MIN	NOM	MAX
Number of Terminals	N	8		
Pitch	e	0.50 BSC		
Overall Height	A	0.70	0.75	0.80
Standoff	A1	0.00	0.02	0.05
Terminal Thickness	(A3)	0.10 REF		
Overall Width	E	2.00 BSC		
Exposed Pad Width	E2	0.70	0.80	0.90
Overall Length	D	2.00 BSC		
Exposed Pad Length	D2	1.10	1.20	1.30
Exposed Pad Chamfer	CH	-	0.25	-
Terminal Width	b	0.20	0.25	0.30
Terminal Length	L	0.25	0.30	0.35
Terminal-to-Exposed-Pad	(K)	0.30	-	-

**Notes:**

1. Pin 1 visual index feature may vary, but must be located within the hatched area.
2. Package is saw singulated
3. Dimensioning and tolerancing per ASME Y14.5M
  - BSC: Basic Dimension. Theoretically exact value shown without tolerances.
  - REF: Reference Dimension, usually without tolerance, for information purposes only.

**Footprint Outlines and Dimensions**

**8-Lead Very, Very Thin Plastic Dual Flat, No Lead Package (RW) - 2x2 mm Body [WDFN]**

**Note:** For the most current package drawings, please see the Microchip Packaging Specification located at <http://www.microchip.com/packaging>

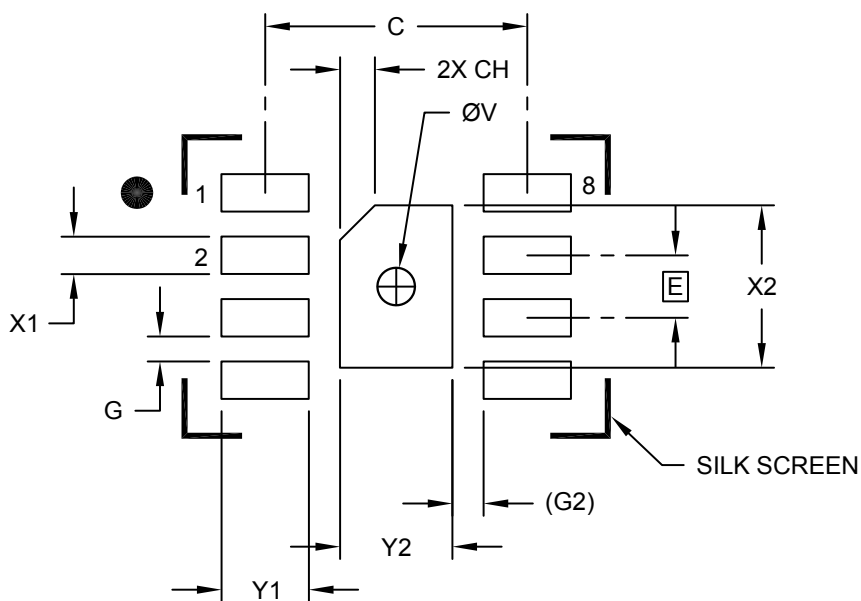

**RECOMMENDED LAND PATTERN**

Units		MILLIMETERS		
Dimension Limits		MIN	NOM	MAX
Contact Pitch	E	0.50 BSC		
Optional Center Pad Width	Y2			0.90
Optional Center Pad Length	X2			1.30
Contact Pad Spacing	C		2.10	
Center Pad Chamfer	CH		0.28	
Contact Pad Width (X8)	X1			0.30
Contact Pad Length (X8)	Y1			0.70
Contact Pad to Contact Pad (X6)	G1	0.20		
Contact Pad to Center Pad (X8)	G1		0.25 REF	
Thermal Via Diameter	V		0.30	

**Notes:**

1. Dimensioning and tolerancing per ASME Y14.5M

BSC: Basic Dimension. Theoretically exact value shown without tolerances.

REF: Reference Dimension, usually without tolerances, for reference only.

Microchip Technology Drawing C04-2261A



**Package Outlines and Dimensions**

**8-Lead Plastic Very, Very Thin Small Outline No-Lead (MF) - 5x6 mm Body [WDFN]**

**Note:** For the most current package drawings, please see the Microchip Packaging Specification located at <http://www.microchip.com/packaging>

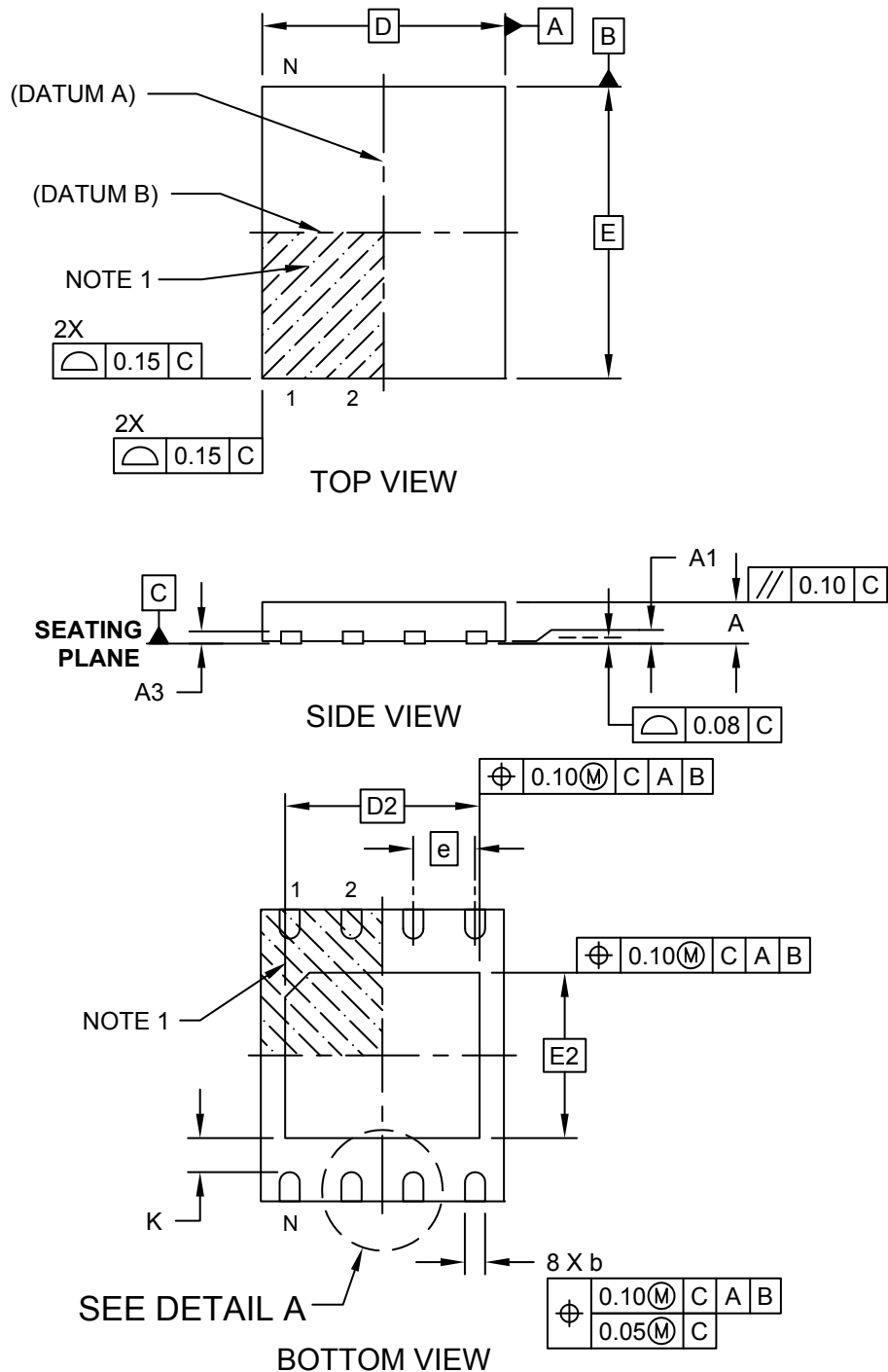

**Package Outlines and Dimensions**

**8-Lead Plastic Very, Very Thin Small Outline No-Lead (MF) - 5x6 mm Body [WDFN]**

**Note:** For the most current package drawings, please see the Microchip Packaging Specification located at <http://www.microchip.com/packaging>

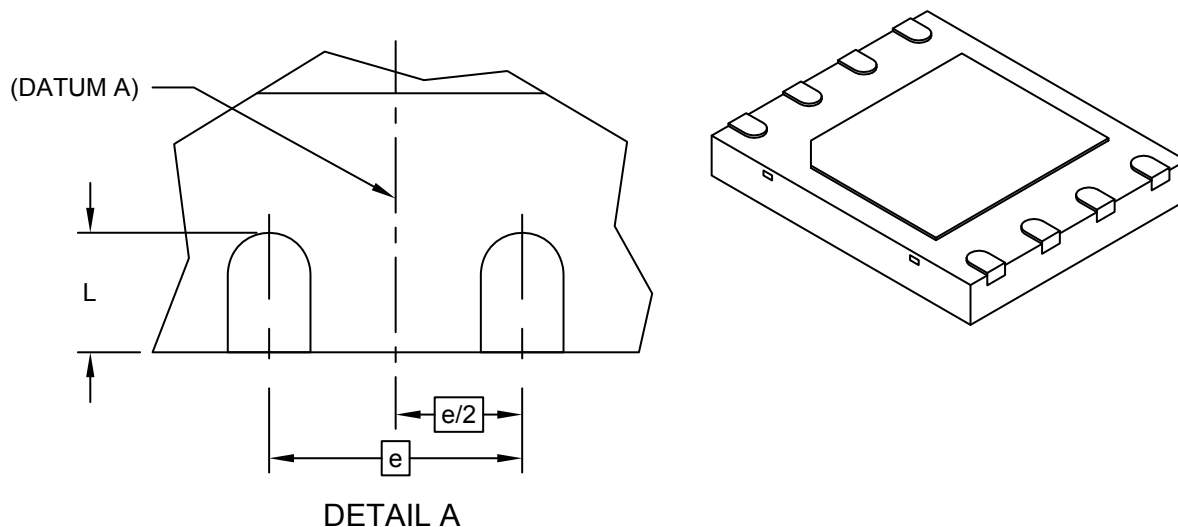

		Units	MILLIMETERS		
Dimension Limits			MIN	NOM	MAX
Number of Terminals	N		8		
Pitch	e		1.27 BSC		
Overall Height	A		0.70	0.75	0.80
Standoff	A1		0.00	0.02	0.05
Terminal Thickness	A3		0.20 REF		
Overall Width	D		5.00 BSC		
Exposed Pad Width	D2		4.00 BSC		
Overall Length	E		6.00 BSC		
Exposed Pad Length	E2		3.40 BSC		
Terminal Width	b		0.35	0.42	0.48
Terminal Length	L		0.50	0.60	0.70
Terminal-to-Exposed-Pad	K		0.20	-	-

**Notes:**

1. Pin 1 visual index feature may vary, but must be located within the hatched area.
2. Package is saw singulated
3. Dimensioning and tolerancing per ASME Y14.5M

BSC: Basic Dimension. Theoretically exact value shown without tolerances.

REF: Reference Dimension, usually without tolerance, for information purposes only.

---



---

## Footprint Outlines and Dimensions

---



---

### 8-Lead Plastic Very, Very Thin Small Outline No-Lead (MF) - 5x6 mm Body [WDFN]

**Note:** For the most current package drawings, please see the Microchip Packaging Specification located at <http://www.microchip.com/packaging>

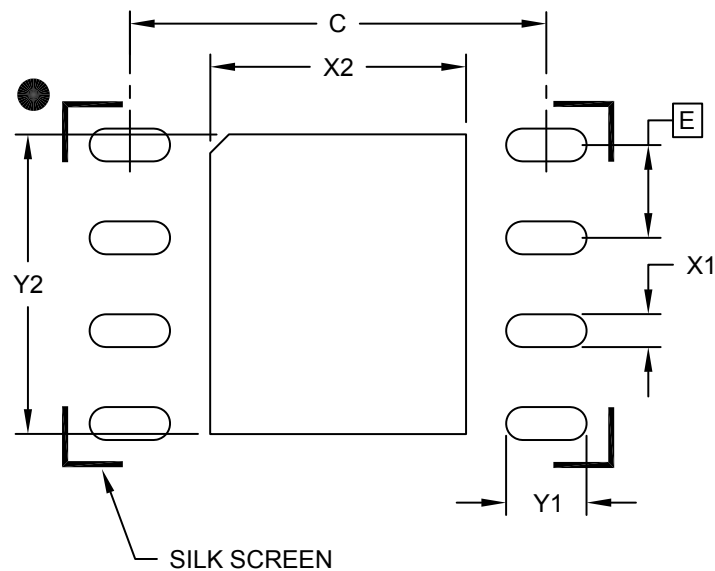

### RECOMMENDED LAND PATTERN

		Units	MILLIMETERS		
Dimension Limits			MIN	NOM	MAX
Contact Pitch	E		1.27 BSC		
Optional Center Pad Width	X2				3.50
Optional Center Pad Length	Y2				4.10
Contact Pad Spacing	C			5.70	
Contact Pad Width (X8)	X1				0.45
Contact Pad Length (X8)	Y1				1.10

**Notes:**

1. Dimensioning and tolerancing per ASME Y14.5M

BSC: Basic Dimension. Theoretically exact value shown without tolerances.

Microchip Technology Drawing C04-2210A

**Package Outlines and Dimensions**

**8-Lead Very, Very Thin Small Outline No-Lead (MN) - 6x8 mm Body [WDFN]  
(Also Called WSON)**

**Note:** For the most current package drawings, please see the Microchip Packaging Specification located at <http://www.microchip.com/packaging>

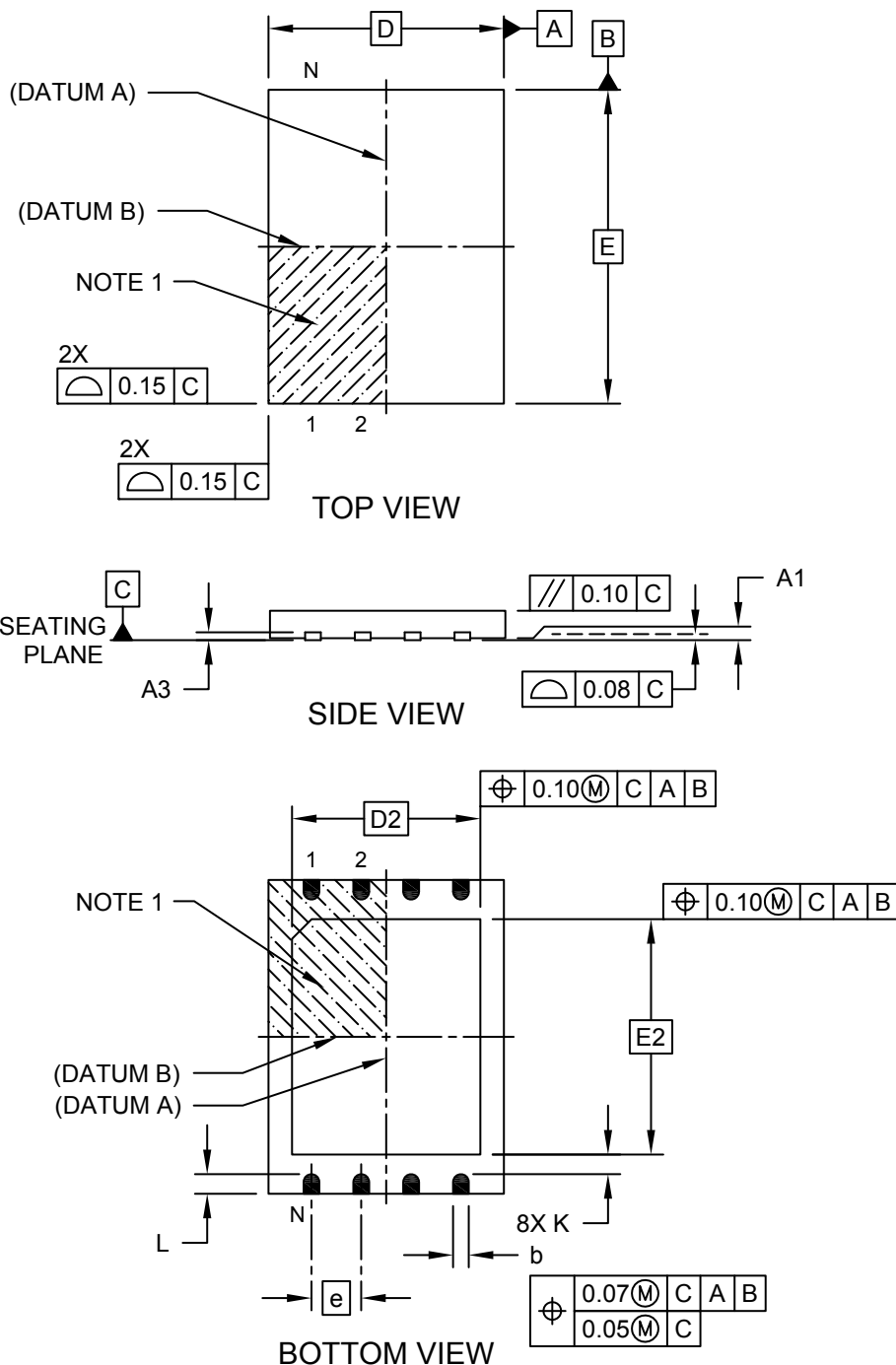

---



---

## Package Outlines and Dimensions

---



---

### 8-Lead Very, Very Thin Small Outline No-Lead (MN) - 6x8 mm Body [WDFN] (Also Called WSON)

**Note:** For the most current package drawings, please see the Microchip Packaging Specification located at <http://www.microchip.com/packaging>

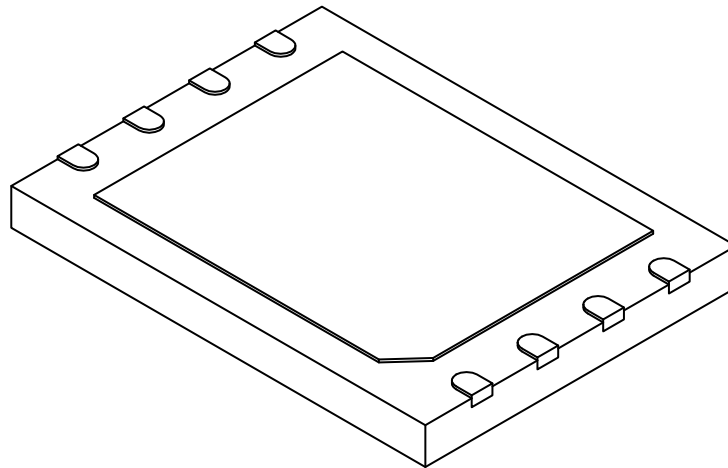

		Units	MILLIMETERS		
Dimension Limits			MIN	NOM	MAX
Number of Terminals	N		8		
Pitch	e		1.27 BSC		
Overall Height	A		0.70	0.75	0.80
Standoff	A1		0.00	0.02	0.05
Terminal Thickness	A3		0.20 REF		
Overall Width	E		8.00 BSC		
Exposed Pad Width	E2		6.00 BSC		
Overall Length	D		6.00 BSC		
Exposed Pad Length	D2		4.80 BSC		
Terminal Width	b		0.35	0.40	0.45
Terminal Length	L		0.45	0.50	0.55
Terminal-to-Exposed-Pad	K		0.20	-	-

**Notes:**

1. Terminal 1 visual index feature may vary, but must be located within the hatched area.
2. Package is saw singulated
3. Dimensioning and tolerancing per ASME Y14.5M
  - BSC: Basic Dimension. Theoretically exact value shown without tolerances.
  - REF: Reference Dimension, usually without tolerance, for information purposes only.

**Footprint Outlines and Dimensions**

**8-Lead Very, Very Thin Small Outline No-Lead (MN) - 6x8 mm Body [WDFN]  
(Also Called WSON)**

**Note:** For the most current package drawings, please see the Microchip Packaging Specification located at <http://www.microchip.com/packageing>

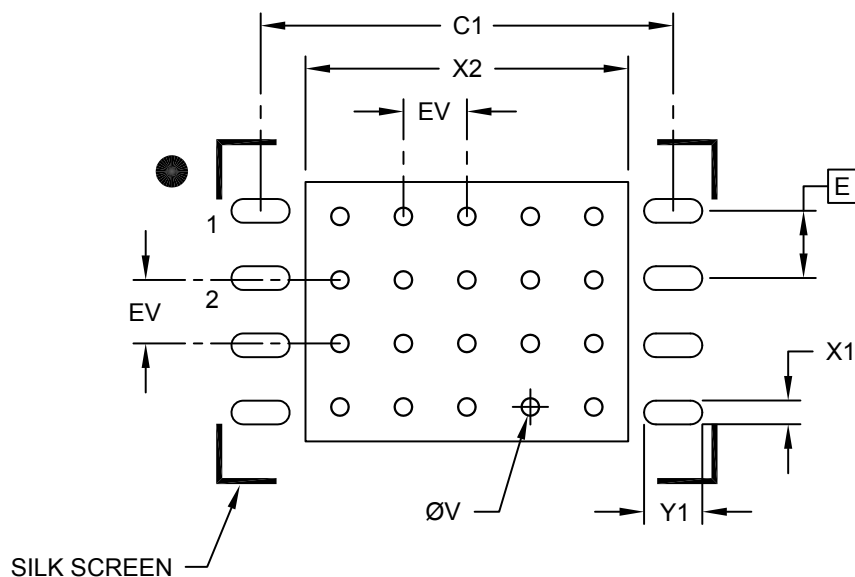

**RECOMMENDED LAND PATTERN**

Dimension Limits	Units	MILLIMETERS		
		MIN	NOM	MAX
Contact Pitch	E	1.27 BSC		
Optional Center Pad Width	X2			6.10
Optional Center Pad Length	Y2			4.90
Contact Pad Spacing	C1		7.80	
Contact Pad Width (X8)	X1			0.45
Contact Pad Length (X8)	Y1			0.95
Thermal Via Diameter	V		0.33	
Thermal Via Pitch	EV		1.20	

**Notes:**

1. Dimensioning and tolerancing per ASME Y14.5M  
BSC: Basic Dimension. Theoretically exact value shown without tolerances.
2. For best soldering results, thermal vias, if used, should be filled or tented to avoid solder loss during reflow process

---

---

**Package Outlines and Dimensions**

---

---

**USON**

**Package Outlines and Dimensions**

**8-Lead Ultra Thin Small Outline No-Leads (ND) - 2x2 mm Body [USON]  
(Also known as UDFN); SST Legacy Package; QU8E/F**

**Note:** For the most current package drawings, please see the Microchip Packaging Specification located at <http://www.microchip.com/packaging>

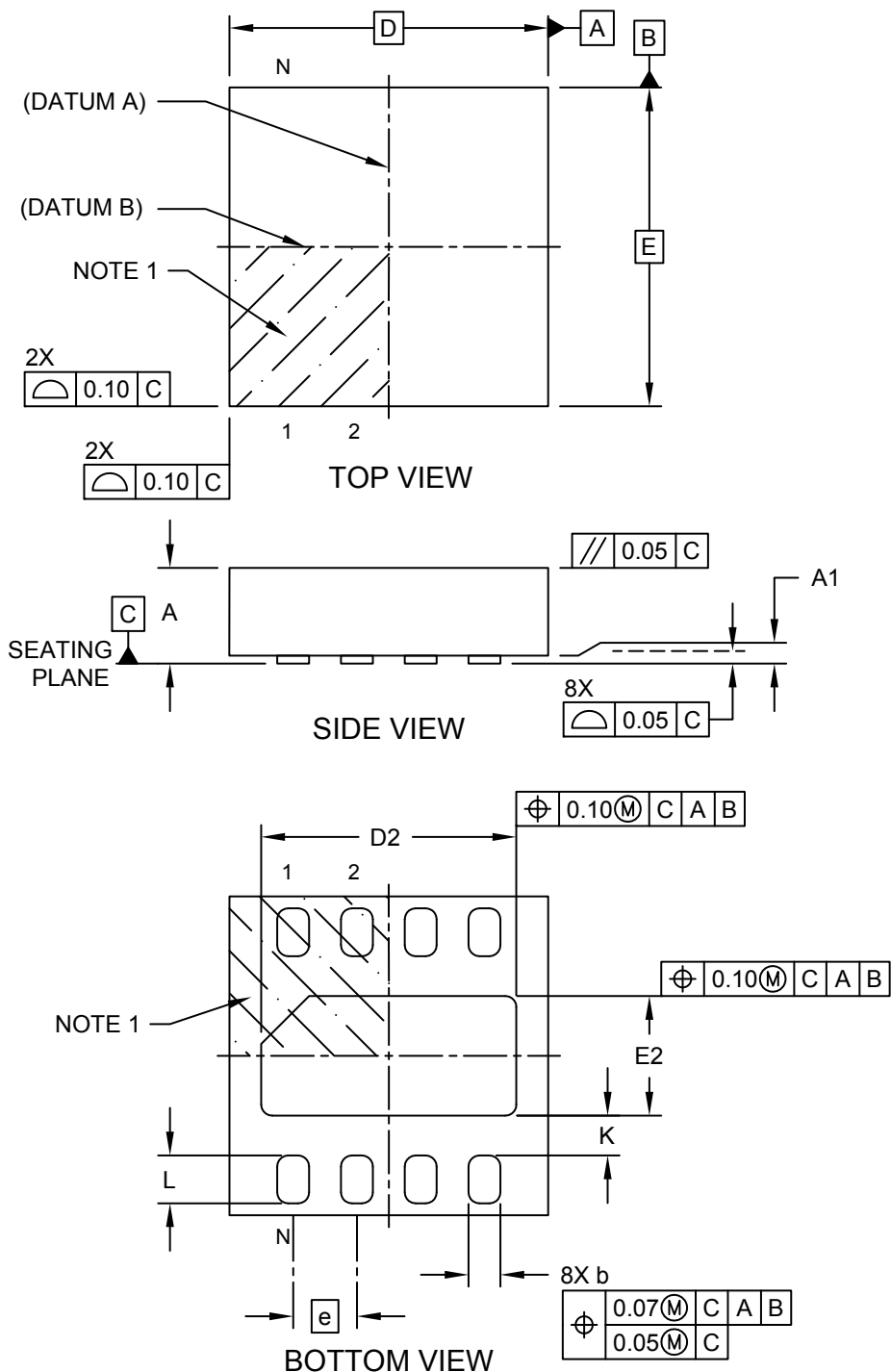

Microchip Technology Drawing C04-200A Sheet 1 of 2



---



---

## Package Outlines and Dimensions

---



---

### 8-Lead Ultra Thin Small Outline No-Leads (ND) - 2x2 mm Body [USON] (Also known as UDFN); SST Legacy Package; QU8E/F

**Note:** For the most current package drawings, please see the Microchip Packaging Specification located at <http://www.microchip.com/packaging>

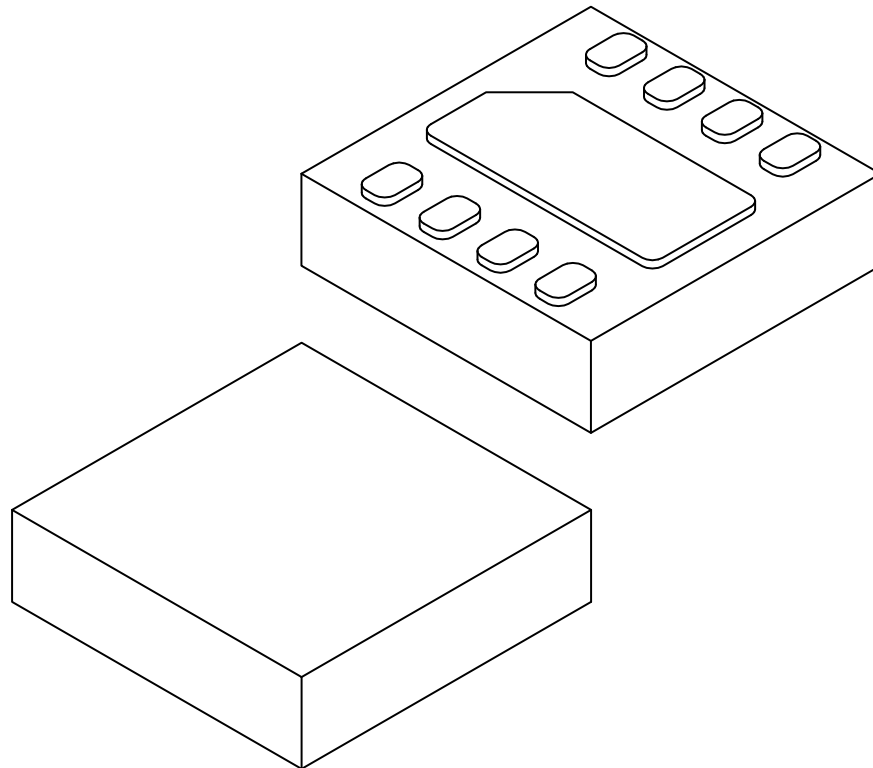

Dimension Limits	Units	MILLIMETERS		
		MIN	NOM	MAX
Number of Terminals	N	8		
Pitch	e	0.40 BSC		
Overall Height	A	0.50	0.55	0.60
Standoff	A1	0.00	0.02	0.05
Overall Length	D	2.00 BSC		
Exposed Pad Length	D2	1.50	1.60	1.70
Overall Width	E	2.00 BSC		
Exposed Pad Width	E2	0.65	0.75	0.85
Terminal Width	b	0.15	0.20	0.25
Terminal Length	L	0.20	0.30	0.40
Terminal-to-Exposed-Pad	K	0.20	-	-

**Notes:**

1. Pin 1 visual index feature may vary, but must be located within the hatched area.
2. Package is saw singulated
3. Dimensioning and tolerancing per ASME Y14.5M

BSC: Basic Dimension. Theoretically exact value shown without tolerances.

REF: Reference Dimension, usually without tolerance, for information purposes only.

**Footprint Outlines and Dimensions**

**8-Lead Ultra Thin Small Outline No-Leads (ND) - 2x2 mm Body [USON]  
(Also known as UDFN); SST Legacy Package; QU8E/F**

**Note:** For the most current package drawings, please see the Microchip Packaging Specification located at <http://www.microchip.com/packaging>

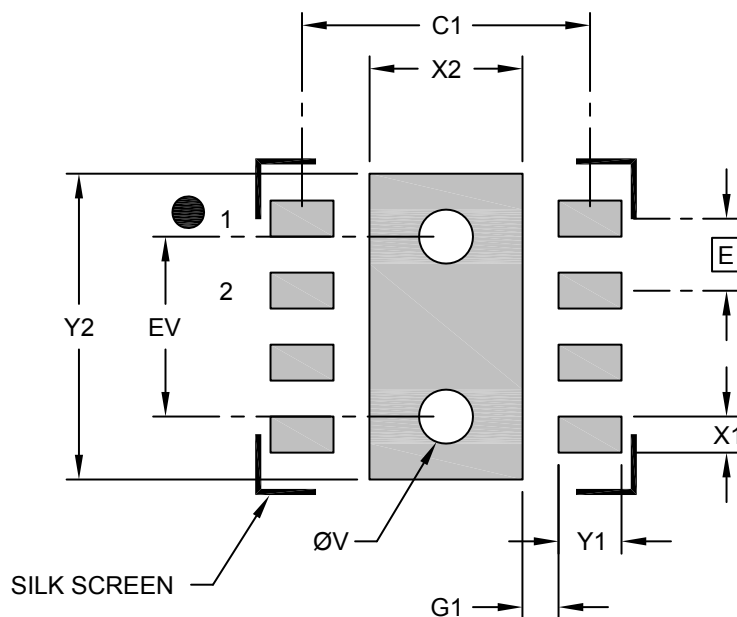

**RECOMMENDED LAND PATTERN**

Dimension Limits	Units	MILLIMETERS		
		MIN	NOM	MAX
Contact Pitch	E	0.40 BSC		
Optional Center Pad Width	X2			0.85
Optional Center Pad Length	Y2			1.70
Contact Pad Spacing	C		1.60	
Contact Pad Width (X8)	X1			0.20
Contact Pad Length (X8)	Y1			0.35
Contact Pad to Center Pad (X8)	G1	0.20		
Thermal Via Diameter	V		0.30	
Thermal Via Pitch	EV		1.00	

**Notes:**

1. Dimensioning and tolerancing per ASME Y14.5M  
BSC: Basic Dimension. Theoretically exact value shown without tolerances.
2. For best soldering results, thermal vias, if used, should be filled or tented to avoid solder loss during reflow process

**Package Outlines and Dimensions**

**8-Lead Plastic Ultra Thin Small Outline No Lead Package (NP) - 2x3 mm Body [USON]  
[Also called UDFN]**

**Note:** For the most current package drawings, please see the Microchip Packaging Specification located at <http://www.microchip.com/packaging>

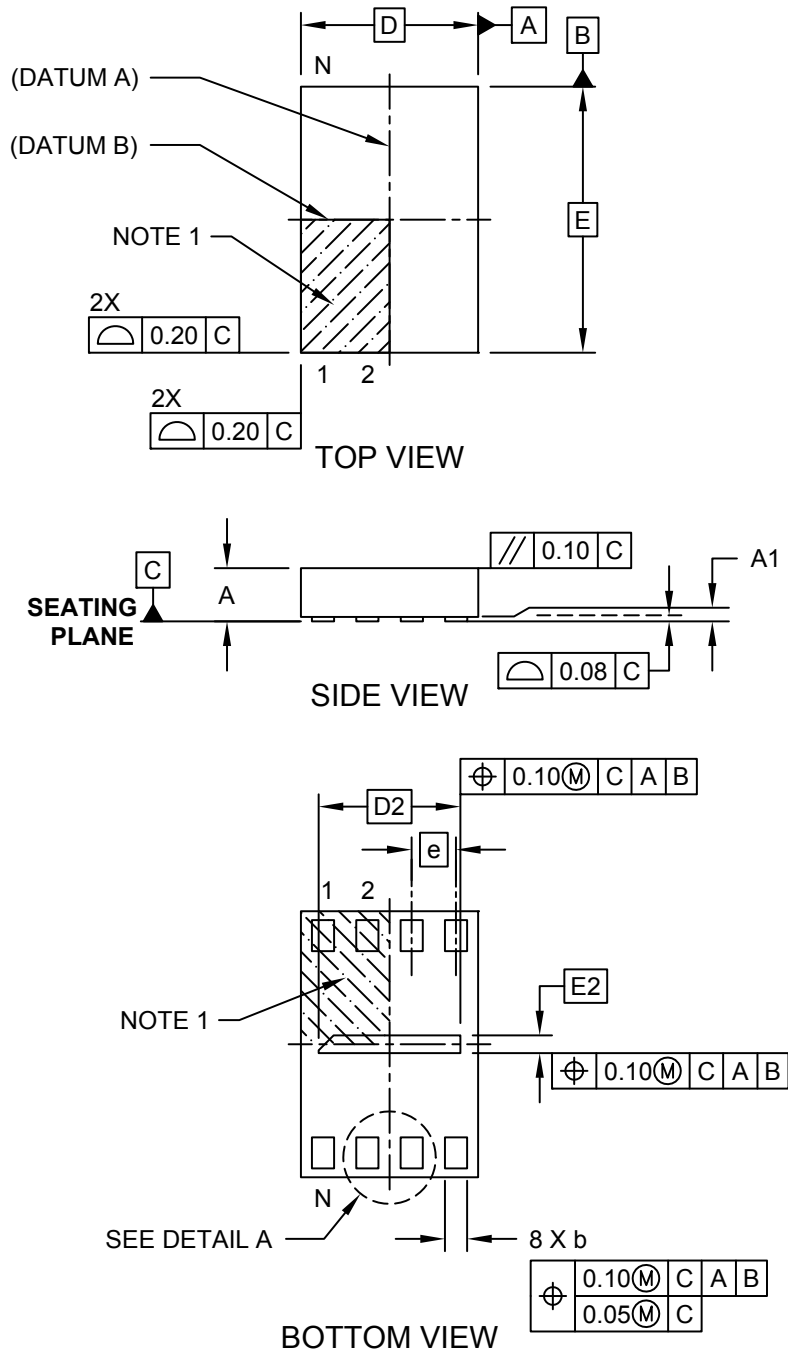

**Package Outlines and Dimensions**

**8-Lead Plastic Ultra Thin Small Outline No Lead Package (NP) - 2x3 mm Body [USON]  
[Also called UDFN]**

**Note:** For the most current package drawings, please see the Microchip Packaging Specification located at <http://www.microchip.com/packaging>

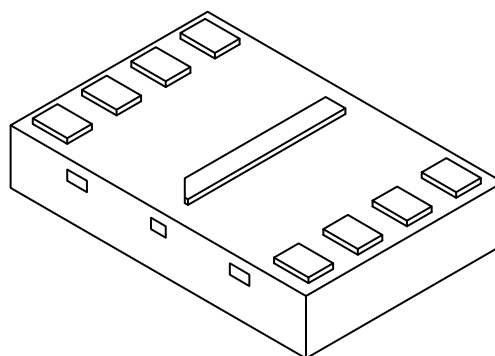
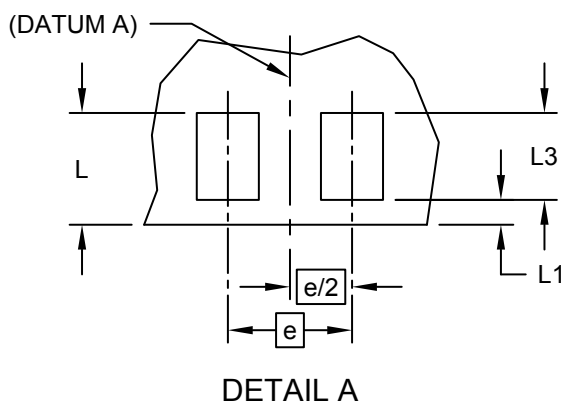

Dimension Limits	Units	MILLIMETERS		
		MIN	NOM	MAX
Number of Terminals	N	8		
Pitch	e	0.50 BSC		
Overall Height	A	0.45	0.55	0.60
Standoff	A1	0.00	0.02	0.05
Overall Width	D	2.00 BSC		
Exposed Pad Width	D2	1.50	1.60	1.70
Overall Length	E	3.00 BSC		
Exposed Pad Length	E2	0.10	0.20	0.30
Terminal Width	b	0.20	0.25	0.30
Package Edge to Terminal Edge	L	0.40	0.45	0.50
Package Edge to Terminal Edge	L1	—	0.10	—
Terminal Length	L3	0.30	0.35	0.40

Notes:

1. Pin 1 visual index feature may vary, but must be located within the hatched area.
2. Package is saw singulated
3. Dimensioning and tolerancing per ASME Y14.5M

BSC: Basic Dimension. Theoretically exact value shown without tolerances.

REF: Reference Dimension, usually without tolerance, for information purposes only.

---



---

## Footprint Outlines and Dimensions

---



---

### 8-Lead Plastic Ultra Thin Small Outline No Lead Package (NP) - 2x3 mm Body [USON] [Also called UDFN]

**Note:** For the most current package drawings, please see the Microchip Packaging Specification located at <http://www.microchip.com/packaging>

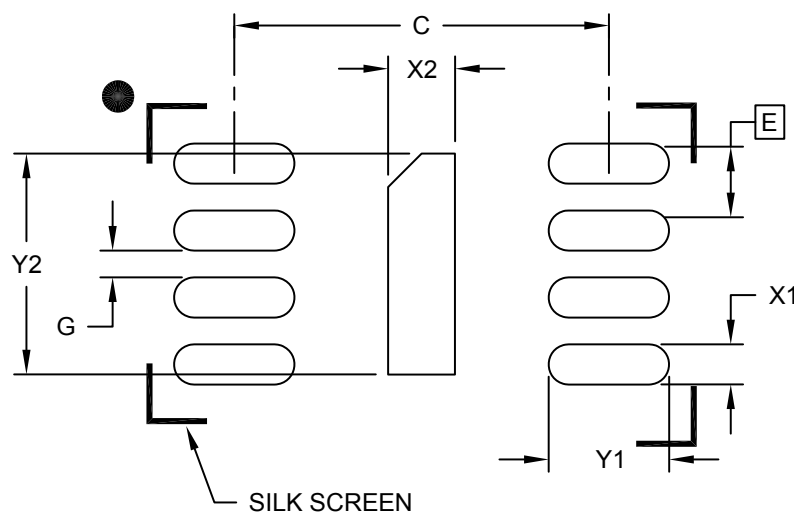

### RECOMMENDED LAND PATTERN

Dimension Limits	Units	MILLIMETERS		
		MIN	NOM	MAX
Terminal Pitch	E	0.50 BSC		
Optional Center Pad Width	X2			0.25
Optional Center Pad Length	Y2			1.65
Terminal Pad Spacing	C		2.80	
Terminal Pad Width (X8)	X1			0.30
Terminal Pad Length (X8)	Y1			0.90
Minimum Between Terminal Pads	G	0.20		

**Notes:**

1. Dimensioning and tolerancing per ASME Y14.5M

BSC: Basic Dimension. Theoretically exact value shown without tolerances.

Microchip Technology Drawing C04-2203B [NP]

**Package Outlines and Dimensions**

**8-Lead Plastic Ultra Thin Small Outline No Lead Package (PRX) - 2x3 mm Body [USON]  
[Also called UDFN]**

**Note:** For the most current package drawings, please see the Microchip Packaging Specification located at <http://www.microchip.com/packaging>

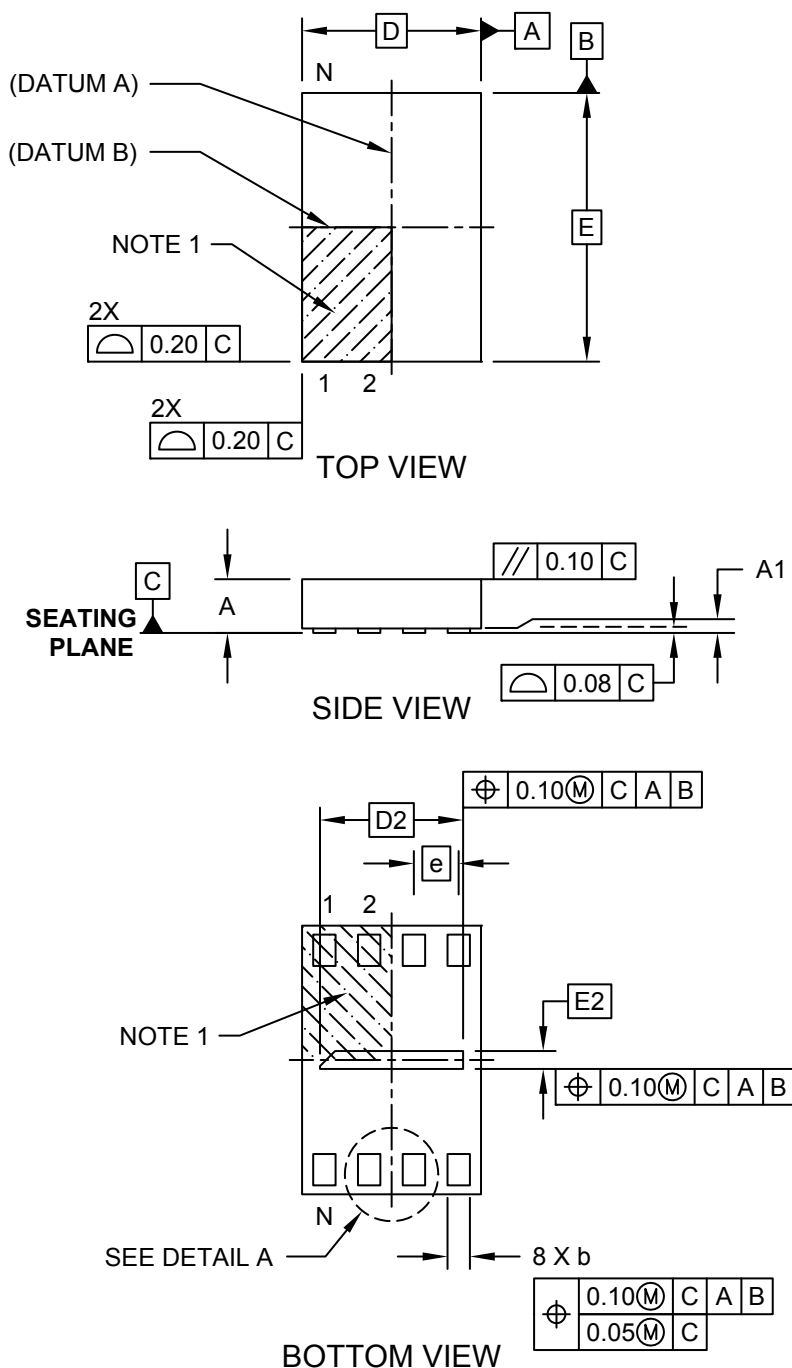

---



---

## Package Outlines and Dimensions

---



---

### 8-Lead Plastic Ultra Thin Small Outline No Lead Package (PRX) - 2x3 mm Body [USON] [Also called UDFN]

**Note:** For the most current package drawings, please see the Microchip Packaging Specification located at <http://www.microchip.com/packaging>

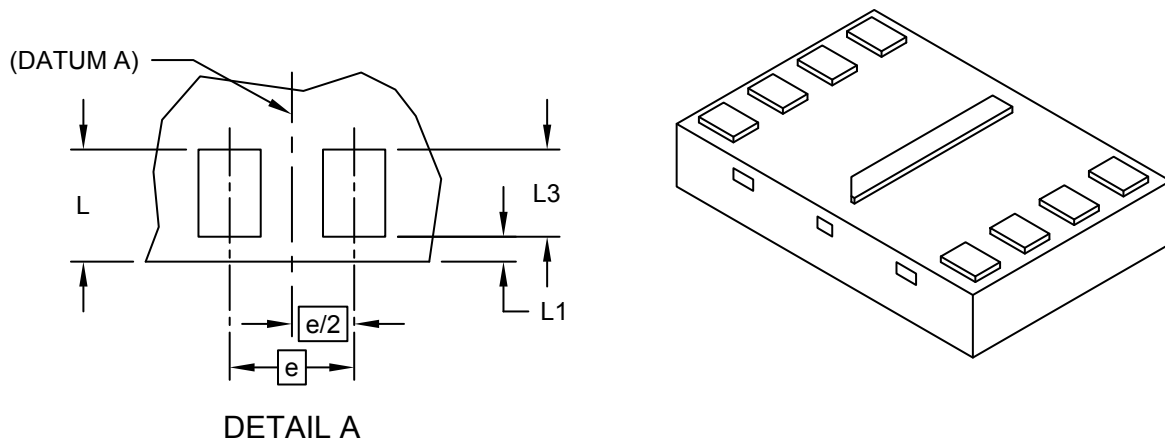

Dimension Limits	Units	MILLIMETERS		
		MIN	NOM	MAX
Number of Terminals	N	8		
Pitch	e	0.50 BSC		
Overall Height	A	0.45	0.55	0.60
Standoff	A1	0.00	0.02	0.05
Overall Width	D	2.00 BSC		
Exposed Pad Width	D2	1.50	1.60	1.70
Overall Length	E	3.00 BSC		
Exposed Pad Length	E2	0.10	0.20	0.30
Terminal Width	b	0.20	0.25	0.30
Package Edge to Terminal Edge	L	0.40	0.45	0.50
Package Edge to Terminal Edge	L1	—	0.10	—
Terminal Length	L3	0.30	0.35	0.40

**Notes:**

1. Pin 1 visual index feature may vary, but must be located within the hatched area.
2. Package is saw singulated
3. Dimensioning and tolerancing per ASME Y14.5M

BSC: Basic Dimension. Theoretically exact value shown without tolerances.

REF: Reference Dimension, usually without tolerance, for information purposes only.

**Footprint Outlines and Dimensions**

**8-Lead Plastic Ultra Thin Small Outline No Lead Package (PRX) - 2x3 mm Body [USON]  
[Also called UDFN]**

**Note:** For the most current package drawings, please see the Microchip Packaging Specification located at <http://www.microchip.com/packaging>

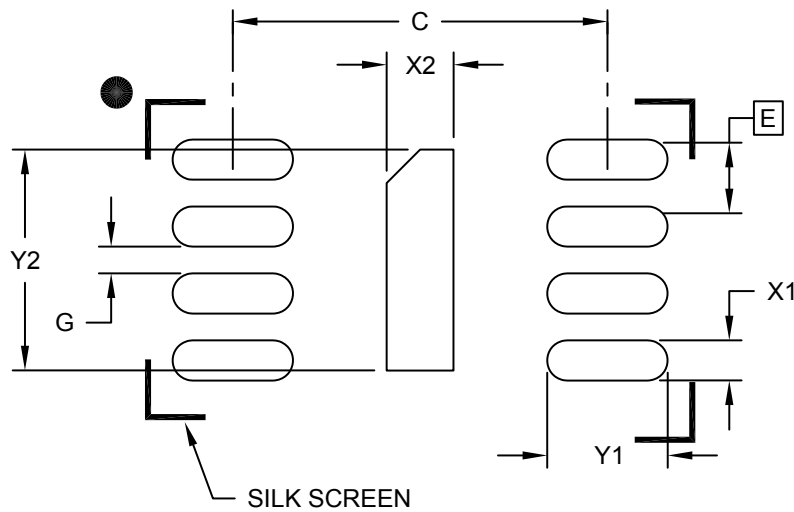

**RECOMMENDED LAND PATTERN**

Dimension Limits	Units	MILLIMETERS		
		MIN	NOM	MAX
Terminal Pitch	E	0.50 BSC		
Optional Center Pad Width	X2			0.30
Optional Center Pad Length	Y2			1.70
Terminal Pad Spacing	C	2.80		
Terminal Pad Width (X8)	X1			0.30
Terminal Pad Length (X8)	Y1			0.90
Minimum Between Terminal Pads	G	0.20		

**Notes:**

1. Dimensioning and tolerancing per ASME Y14.5M

BSC: Basic Dimension. Theoretically exact value shown without tolerances.

Microchip Technology Drawing C04-2203B [PRX]



**Package Outlines and Dimensions**

**8-Terminal Plastic Ultra Thin Dual Flat No Lead Package (UB) -  
4x3x0.55 mm Body [UDFN (USON)]**

**Note:** For the most current package drawings, please see the Microchip Packaging Specification located at <http://www.microchip.com/packaging>

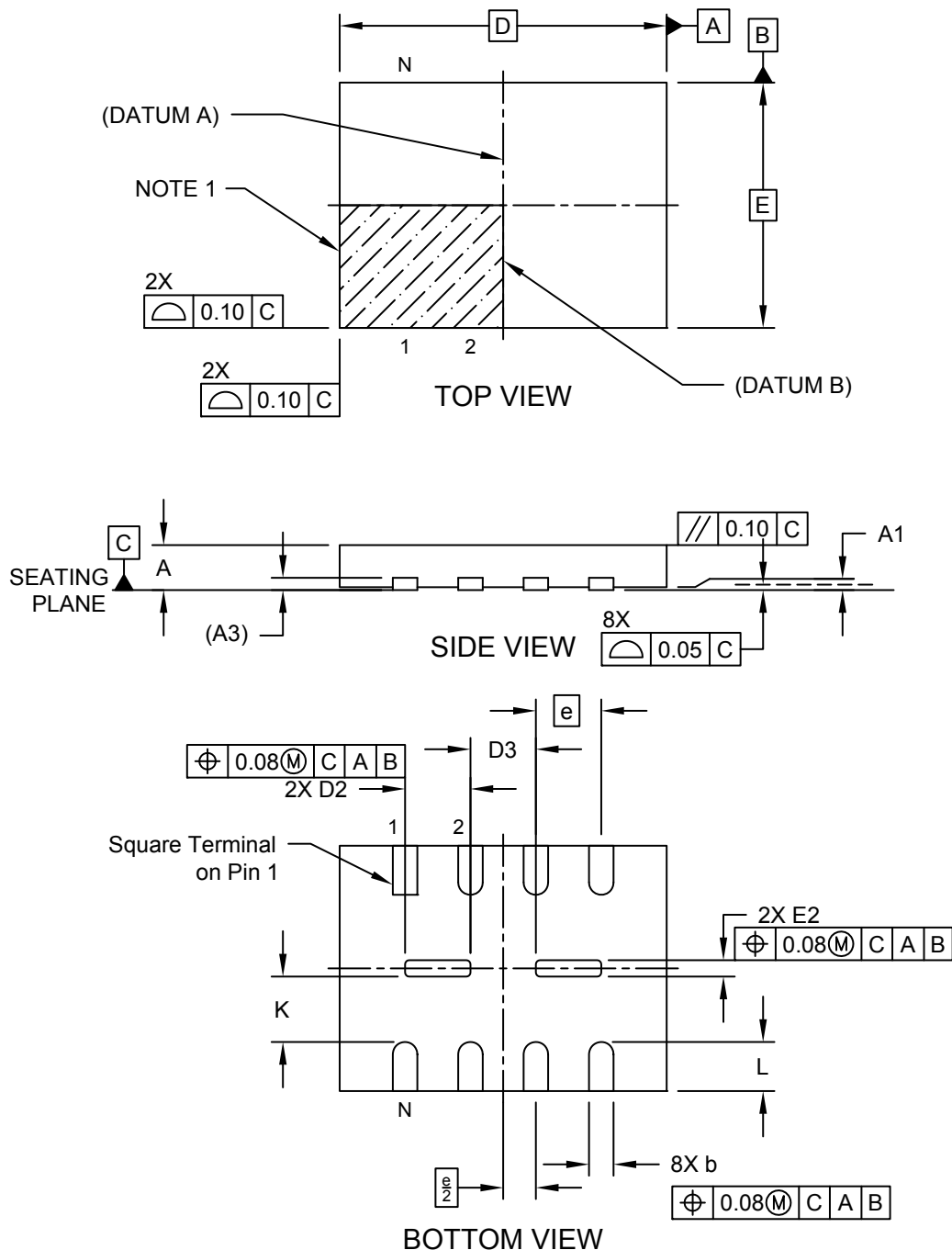

**Package Outlines and Dimensions**

**8-Terminal Plastic Ultra Thin Dual Flat No Lead Package (UB) -  
4x3x0.55 mm Body [UDFN (USON)]**

**Note:** For the most current package drawings, please see the Microchip Packaging Specification located at <http://www.microchip.com/packaging>

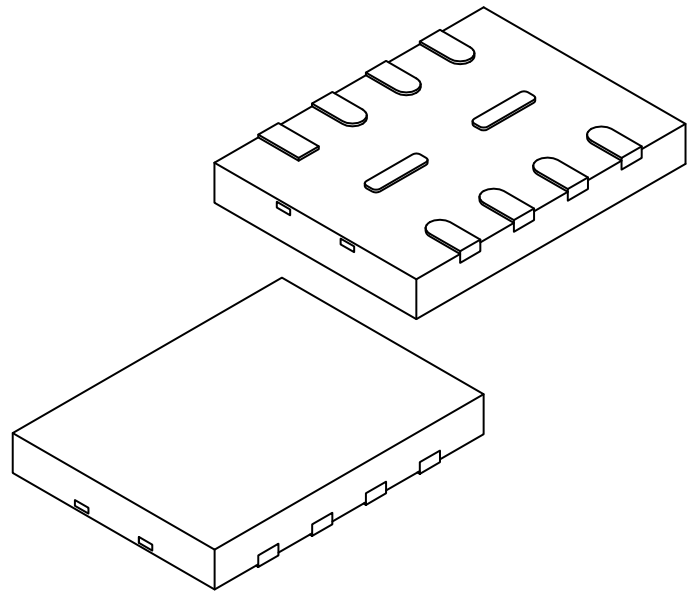

		Units	MILLIMETERS		
Dimension Limits			MIN	NOM	MAX
Number of Pins	N		8		
Pitch	e		0.80 BSC		
Overall Height	A	0.45	0.55	0.60	
Standoff	A1	0.00	0.02	0.05	
Terminal Thickness	A3	0.127 REF			
Overall Width	E	3.00 BSC			
Exposed Pad Width	E2	0.17	0.20	0.23	
Overall Length	D	4.00 BSC			
Exposed Pad Length	D2	0.77	0.80	0.83	
Distance Between Exposed Pads	D3	0.77	0.80	0.83	
Terminal Width	b	0.25	0.30	0.35	
Terminal Length	L	0.55	0.60	0.65	
Terminal-to-Exposed-Pad	K	0.70	-	-	

Notes:

- Pin 1 visual index feature may vary, but must be located within the hatched area.
- Package is saw singulated
- Dimensioning and tolerancing per ASME Y14.5M

BSC: Basic Dimension. Theoretically exact value shown without tolerances.

REF: Reference Dimension, usually without tolerance, for information purposes only.

---



---

## Footprint Outlines and Dimensions

---



---

### 8-Terminal Plastic Ultra Thin Dual Flat No Lead Package (UB) - 4x3x0.55 mm Body [UDFN (USON)]

**Note:** For the most current package drawings, please see the Microchip Packaging Specification located at <http://www.microchip.com/packaging>

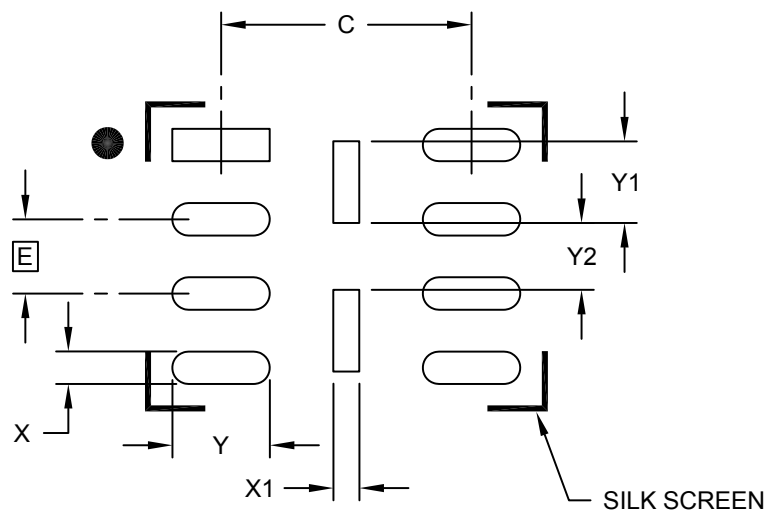

### RECOMMENDED LAND PATTERN

Dimension Limits	Units	MILLIMETERS		
		MIN	NOM	MAX
Contact Pitch	E	0.80 BSC		
Optional Center Pad Width	X1			0.28
Center Pad Length (X2)	Y1			0.88
Center Pad Spacing	Y2	0.72		
Contact Pad Spacing	C		2.70	
Contact Pad Width (X8)	X			0.35
Contact Pad Length (X8)	Y			1.05

**Notes:**

1. Dimensioning and tolerancing per ASME Y14.5M

BSC: Basic Dimension. Theoretically exact value shown without tolerances.

Microchip Technology Drawing C04-2271A



**MICROCHIP**

---

---

**Package Outlines and Dimensions**

---

---

NOTES:

---

---

**Package Outlines and Dimensions**

---

---

**WSO**

**Package Outlines and Dimensions**

**8-Lead Very, Very Thin Small Outline No-Lead (MN) - 6x8 mm Body [WDFN]  
(Also Called WSON)**

**Note:** For the most current package drawings, please see the Microchip Packaging Specification located at <http://www.microchip.com/packaging>

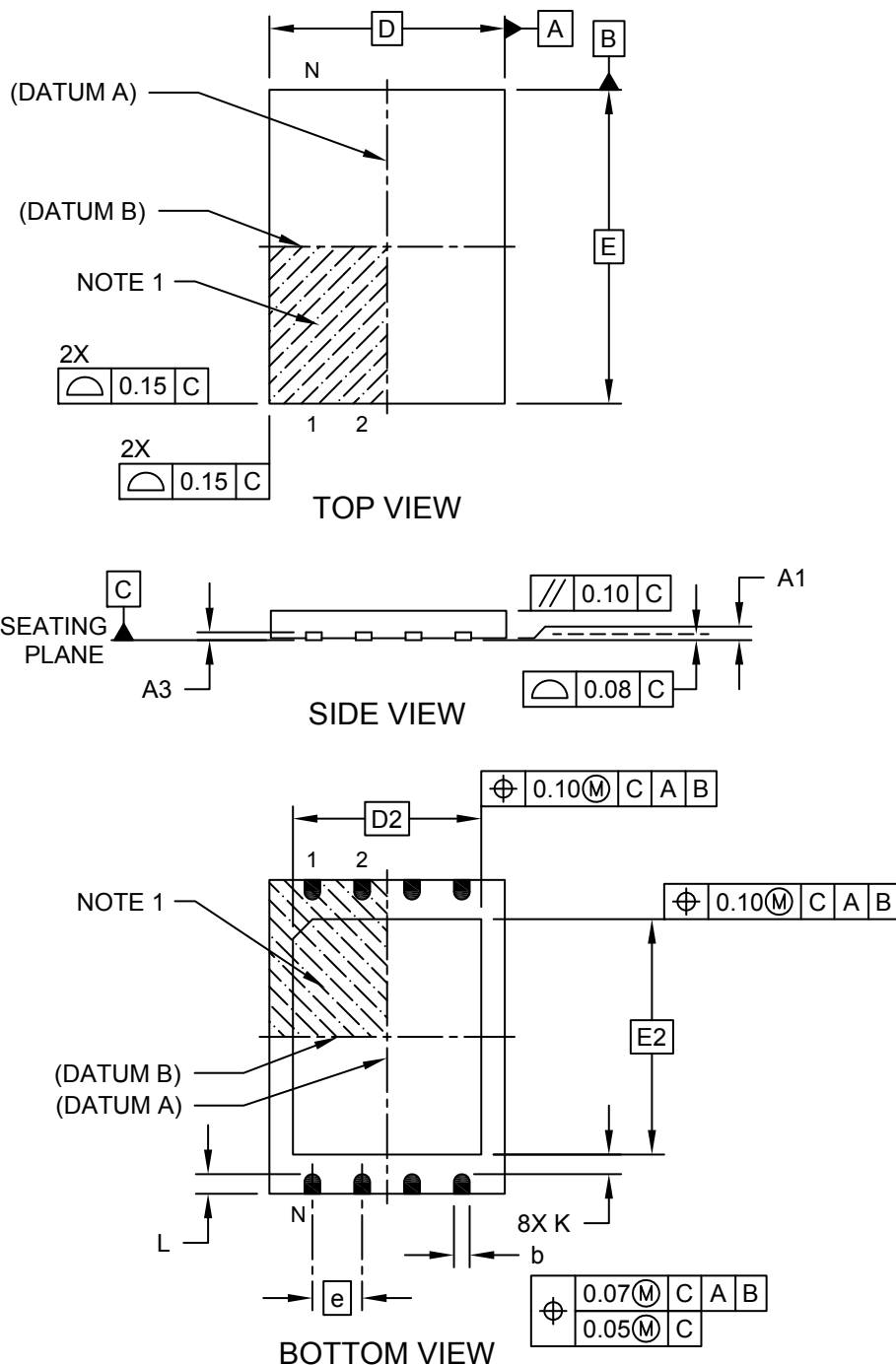

---



---

## Package Outlines and Dimensions

---



---

### 8-Lead Very, Very Thin Small Outline No-Lead (MN) - 6x8 mm Body [WDFN] (Also Called WSON)

**Note:** For the most current package drawings, please see the Microchip Packaging Specification located at <http://www.microchip.com/packaging>

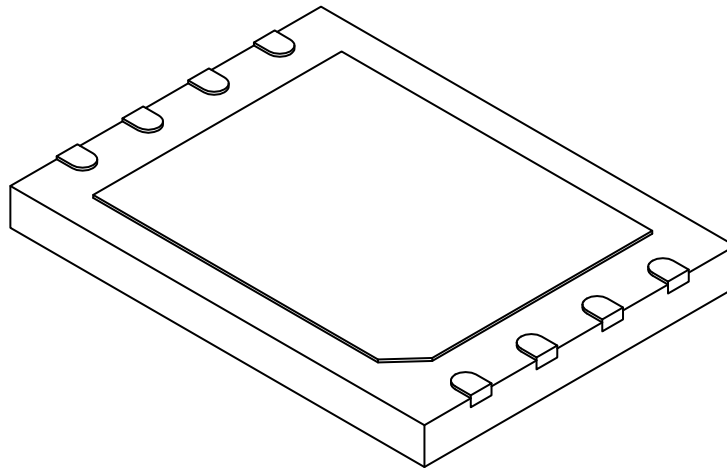

		Units		MILLIMETERS		
Dimension Limits		MIN	NOM	MAX		
Number of Terminals	N	8				
Pitch	e	1.27 BSC				
Overall Height	A	0.70	0.75	0.80		
Standoff	A1	0.00	0.02	0.05		
Terminal Thickness	A3	0.20 REF				
Overall Width	E	8.00 BSC				
Exposed Pad Width	E2	6.00 BSC				
Overall Length	D	6.00 BSC				
Exposed Pad Length	D2	4.80 BSC				
Terminal Width	b	0.35	0.40	0.45		
Terminal Length	L	0.45	0.50	0.55		
Terminal-to-Exposed-Pad	K	0.20	-	-		

**Notes:**

1. Terminal 1 visual index feature may vary, but must be located within the hatched area.
2. Package is saw singulated
3. Dimensioning and tolerancing per ASME Y14.5M
  - BSC: Basic Dimension. Theoretically exact value shown without tolerances.
  - REF: Reference Dimension, usually without tolerance, for information purposes only.

**Footprint Outlines and Dimensions**

**8-Lead Very, Very Thin Small Outline No-Lead (MN) - 6x8 mm Body [WDFN]  
(Also Called WSON)**

**Note:** For the most current package drawings, please see the Microchip Packaging Specification located at <http://www.microchip.com/packaging>

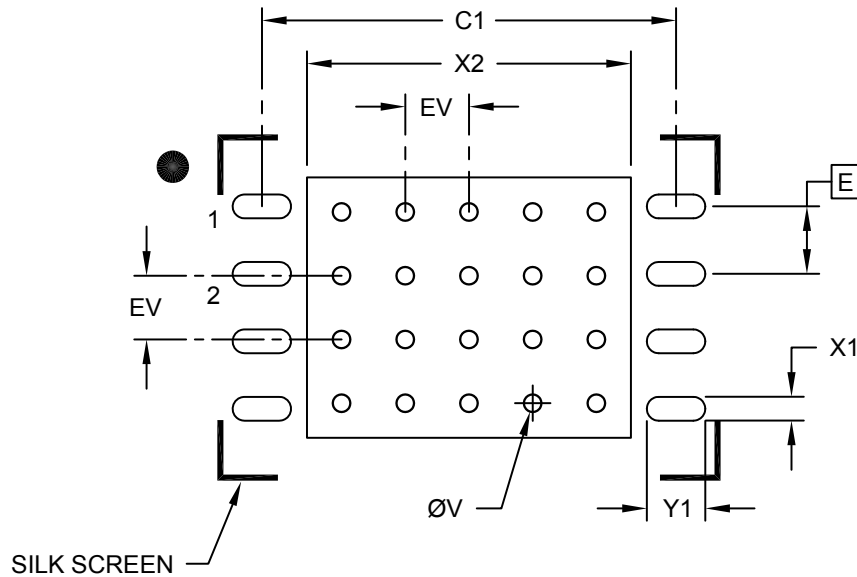

**RECOMMENDED LAND PATTERN**

Units		MILLIMETERS		
Dimension Limits		MIN	NOM	MAX
Contact Pitch	E	1.27 BSC		
Optional Center Pad Width	X2			6.10
Optional Center Pad Length	Y2			4.90
Contact Pad Spacing	C1		7.80	
Contact Pad Width (X8)	X1			0.45
Contact Pad Length (X8)	Y1			0.95
Thermal Via Diameter	V		0.33	
Thermal Via Pitch	EV		1.20	

**Notes:**

1. Dimensioning and tolerancing per ASME Y14.5M  
BSC: Basic Dimension. Theoretically exact value shown without tolerances.
2. For best soldering results, thermal vias, if used, should be filled or tented to avoid solder loss during reflow process



**Package Outlines and Dimensions**

**8-Lead Plastic Very, Very Thin Small Outline No-Lead (MF) - 5x6 mm Body [WDFN]**

**Note:** For the most current package drawings, please see the Microchip Packaging Specification located at <http://www.microchip.com/packaging>

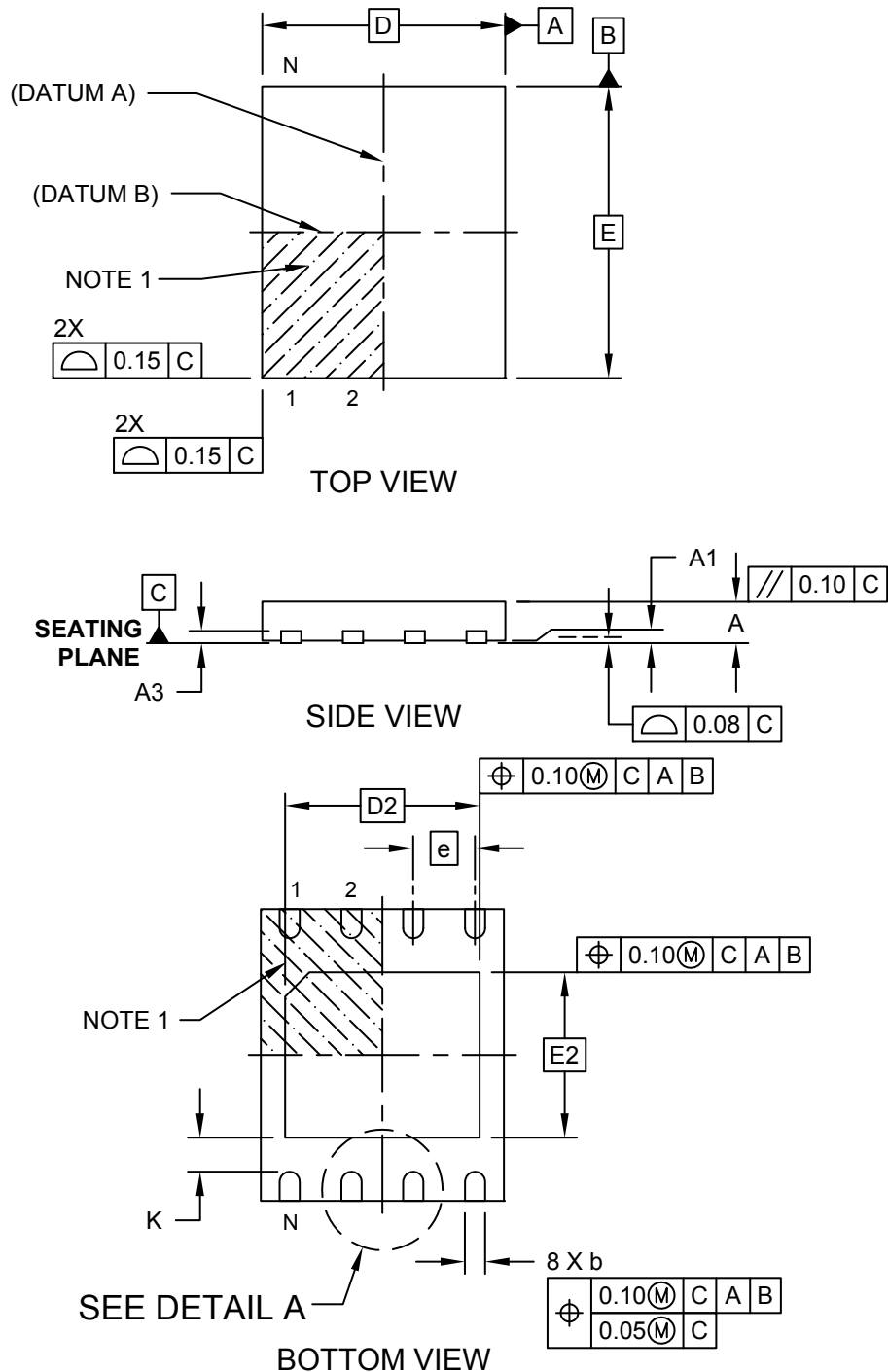

**Package Outlines and Dimensions**

**8-Lead Plastic Very, Very Thin Small Outline No-Lead (MF) - 5x6 mm Body [WDFN]**

**Note:** For the most current package drawings, please see the Microchip Packaging Specification located at <http://www.microchip.com/packaging>

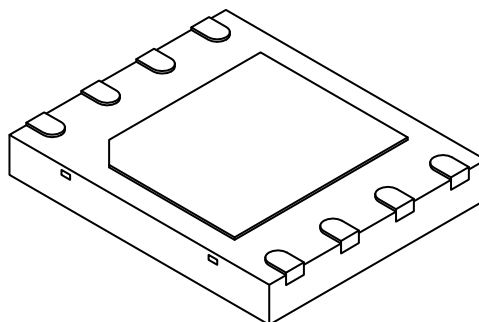
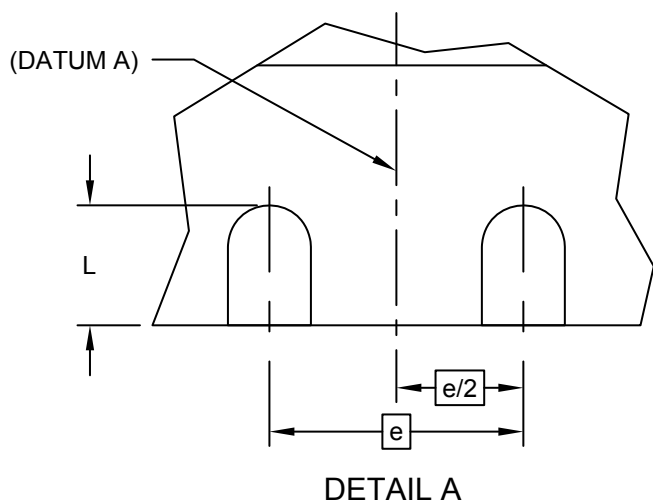

		Units	MILLIMETERS		
Dimension Limits			MIN	NOM	MAX
Number of Terminals	N		8		
Pitch	e		1.27 BSC		
Overall Height	A		0.70	0.75	0.80
Standoff	A1		0.00	0.02	0.05
Terminal Thickness	A3		0.20 REF		
Overall Width	D		5.00 BSC		
Exposed Pad Width	D2		4.00 BSC		
Overall Length	E		6.00 BSC		
Exposed Pad Length	E2		3.40 BSC		
Terminal Width	b		0.35	0.42	0.48
Terminal Length	L		0.50	0.60	0.70
Terminal-to-Exposed-Pad	K		0.20	-	-

**Notes:**

- Pin 1 visual index feature may vary, but must be located within the hatched area.
- Package is saw singulated
- Dimensioning and tolerancing per ASME Y14.5M

BSC: Basic Dimension. Theoretically exact value shown without tolerances.

REF: Reference Dimension, usually without tolerance, for information purposes only.

---



---

## Footprint Outlines and Dimensions

---



---

### 8-Lead Plastic Very, Very Thin Small Outline No-Lead (MF) - 5x6 mm Body [WDFN]

**Note:** For the most current package drawings, please see the Microchip Packaging Specification located at <http://www.microchip.com/packaging>

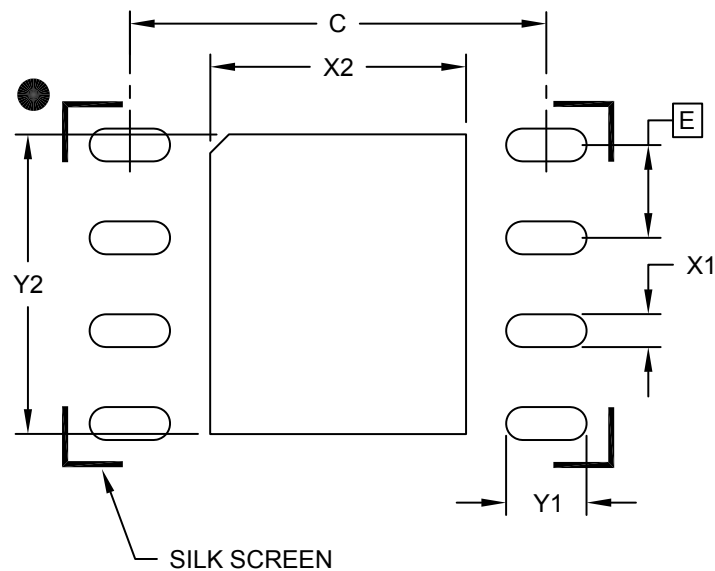

RECOMMENDED LAND PATTERN

		Units	MILLIMETERS		
Dimension Limits			MIN	NOM	MAX
Contact Pitch	E		1.27 BSC		
Optional Center Pad Width	X2				3.50
Optional Center Pad Length	Y2				4.10
Contact Pad Spacing	C			5.70	
Contact Pad Width (X8)	X1				0.45
Contact Pad Length (X8)	Y1				1.10

**Notes:**

1. Dimensioning and tolerancing per ASME Y14.5M

BSC: Basic Dimension. Theoretically exact value shown without tolerances.

Microchip Technology Drawing C04-2210A



**MICROCHIP**

---

---

**Package Outlines and Dimensions**

---

---

NOTES:

---

---

**Package Outlines and Dimensions**

---

---

**XSON**

**Package Outlines and Dimensions**

**8-Lead Extremely Thin Small Outline No-Leads (NF) – 2x2x0.45 mm Body [XSON]**

**Note:** For the most current package drawings, please see the Microchip Packaging Specification located at <http://www.microchip.com/packaging>

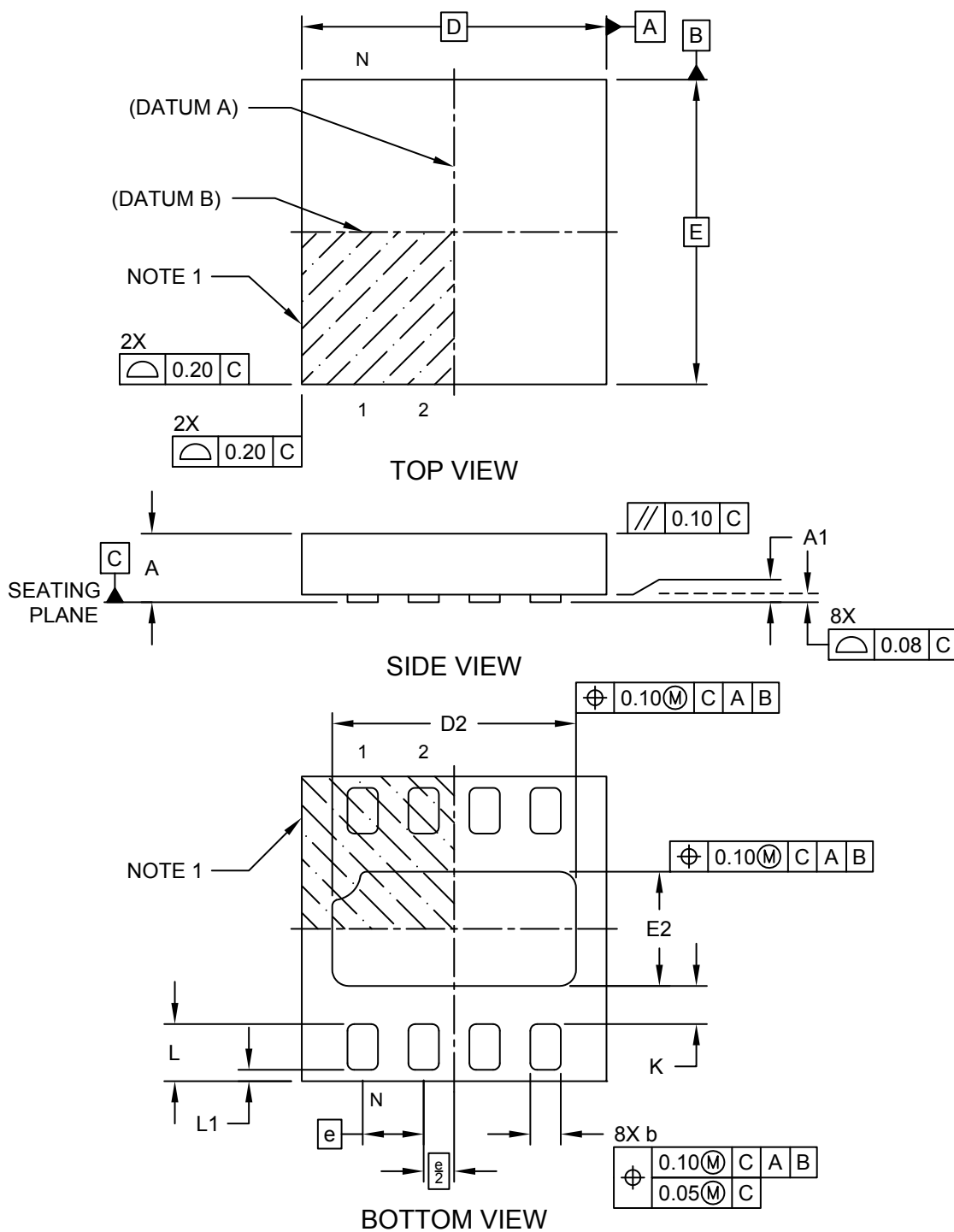

---



---

## Package Outlines and Dimensions

---



---

### 8-Lead Extremely Thin Small Outline No-Leads (NF) – 2x2x0.45 mm Body [XSON]

**Note:** For the most current package drawings, please see the Microchip Packaging Specification located at <http://www.microchip.com/packaging>

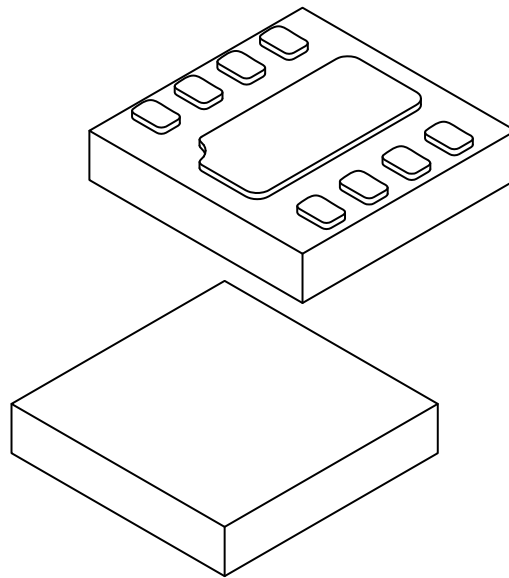

Dimension	Units	MILLIMETERS		
		Limits	MIN	NOM
Number of Pins	N	8		
Pitch	e	0.40 BSC		
Overall Height	A	0.40	0.45	0.50
Standoff	A1	—	—	0.05
Terminal Length	L	0.325	0.375	0.425
Pull Back	L1	—	—	0.075
Overall Length	D	2.00 BSC		
Overall Width	E	2.00 BSC		
Exposed Pad Length	D2	1.55	1.60	1.65
Exposed Pad Width	E2	0.70	0.75	0.80
Terminal Width	b	0.15	0.20	0.25
Terminal to Exposed Pad	K	0.20	—	—

**Notes:**

1. Terminal 1 visual index feature may vary, but must be located within the hatched area.
2. Exact shape at each corner may vary.
3. Dimensioning and tolerancing per ASME Y14.5M.
  - BSC: Basic Dimension. Theoretically exact value shown without tolerances.
  - REF: Reference Dimension, usually without tolerance, for information purposes only.

**Package Outlines and Dimensions**

**8-Lead Extremely Thin Small Outline No-Leads (QX8E) – 2x2x0.45 mm Body [XSON]**

**Note:** For the most current package drawings, please see the Microchip Packaging Specification located at <http://www.microchip.com/packaging>

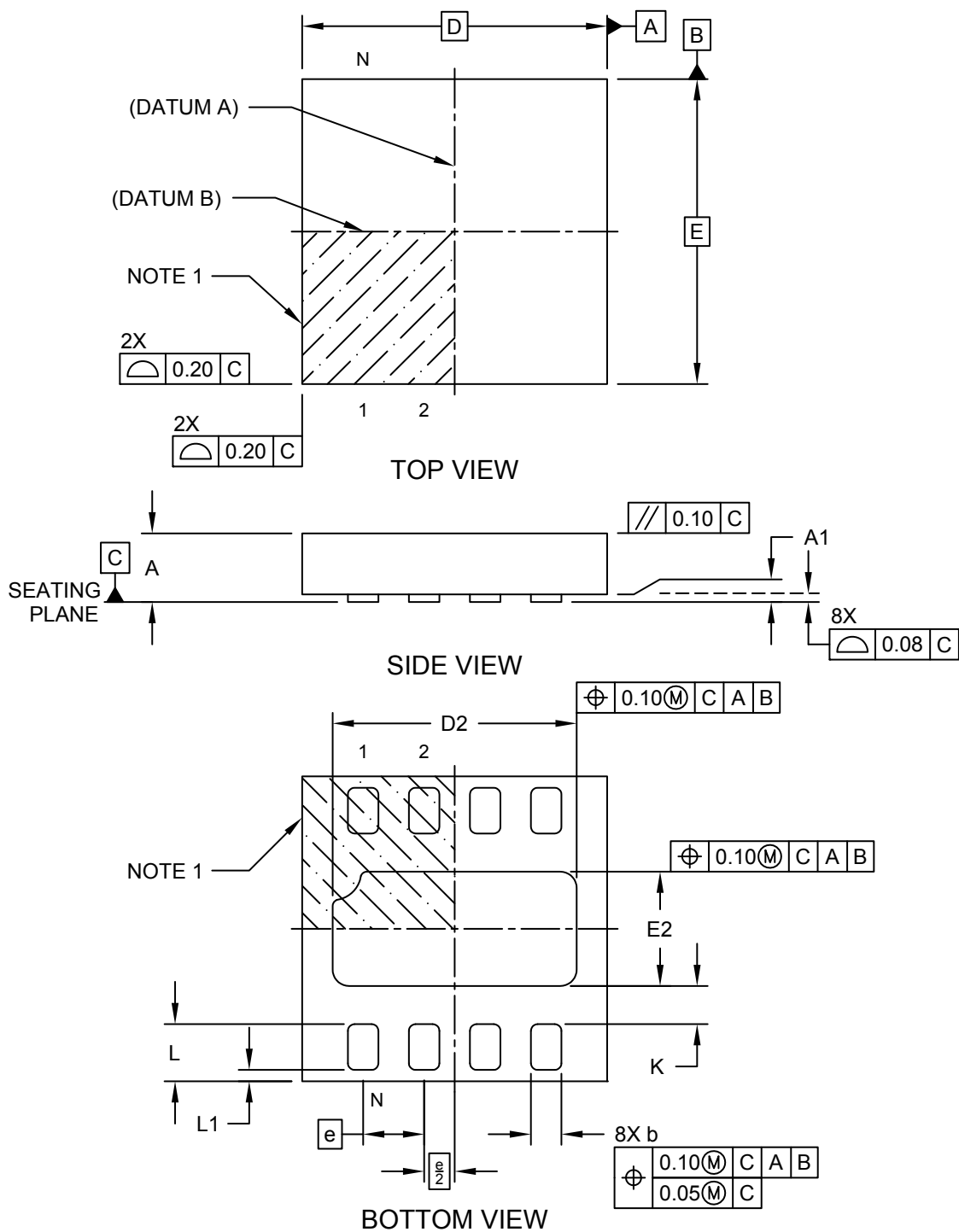



---



---

## Package Outlines and Dimensions

---



---

### 8-Lead Extremely Thin Small Outline No-Leads (QX8E) – 2x2x0.45 mm Body [XSON]

**Note:** For the most current package drawings, please see the Microchip Packaging Specification located at <http://www.microchip.com/packaging>

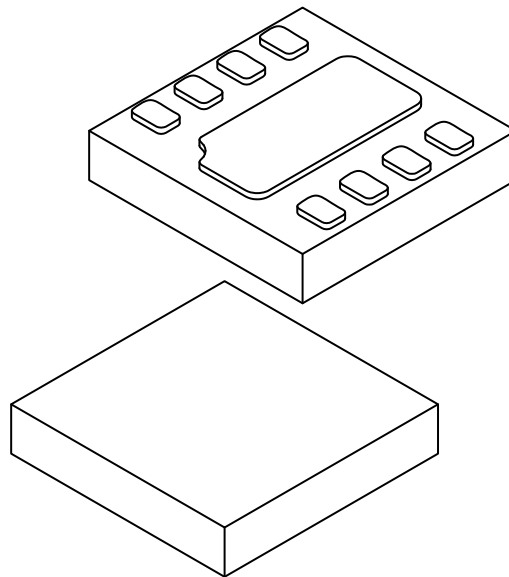

Dimension	Units	MILLIMETERS		
		Limits	MIN	NOM
Number of Pins	N	8		
Pitch	e	0.40 BSC		
Overall Height	A	0.40	0.45	0.50
Standoff	A1	—	—	0.05
Terminal Length	L	0.325	0.375	0.425
Pull Back	L1	—	—	0.075
Overall Length	D	2.00 BSC		
Overall Width	E	2.00 BSC		
Exposed Pad Length	D2	1.55	1.60	1.65
Exposed Pad Width	E2	0.70	0.75	0.80
Terminal Width	b	0.15	0.20	0.25
Terminal to Exposed Pad	K	0.20	—	—

**Notes:**

1. Terminal 1 visual index feature may vary, but must be located within the hatched area.
2. Exact shape at each corner may vary.
3. Dimensioning and tolerancing per ASME Y14.5M.
  - BSC: Basic Dimension. Theoretically exact value shown without tolerances.
  - REF: Reference Dimension, usually without tolerance, for information purposes only.



**MICROCHIP**

---

---

**Package Outlines and Dimensions**

---

---

**NOTES:**

---

---

**Package Outlines and Dimensions**

---

---

**X2SON**

**Package Outlines and Dimensions**

**6-Lead Plastic Super Thin Small Outline No Lead (NR) - 1.5x1.5x0.4 mm Body [X2SON]**

**Note:** For the most current package drawings, please see the Microchip Packaging Specification located at <http://www.microchip.com/packaging>

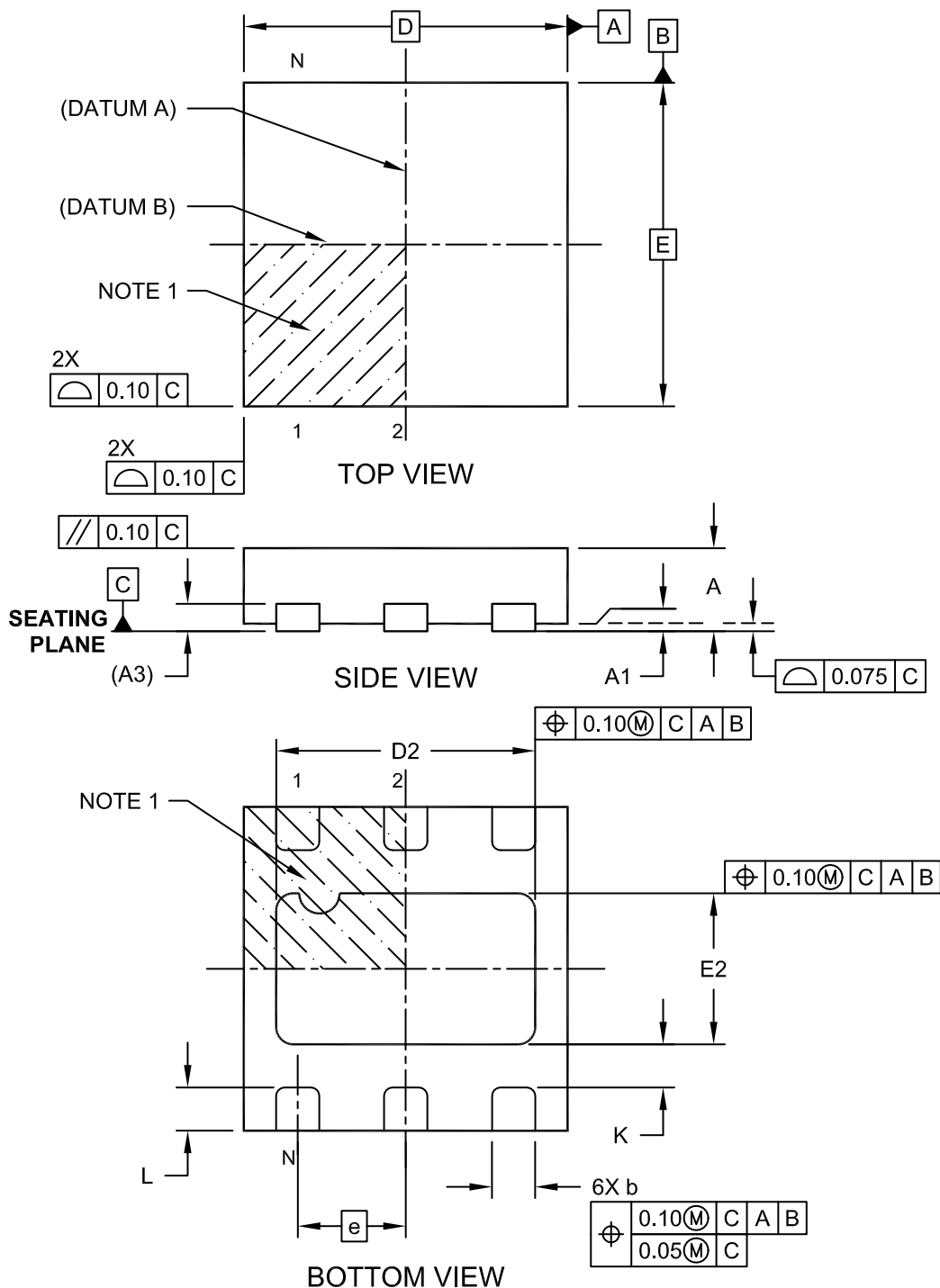

---



---

## Package Outlines and Dimensions

---



---

### 6-Lead Plastic Super Thin Small Outline No Lead (NR) - 1.5x1.5x0.4 mm Body [X2SON]

**Note:** For the most current package drawings, please see the Microchip Packaging Specification located at <http://www.microchip.com/packaging>

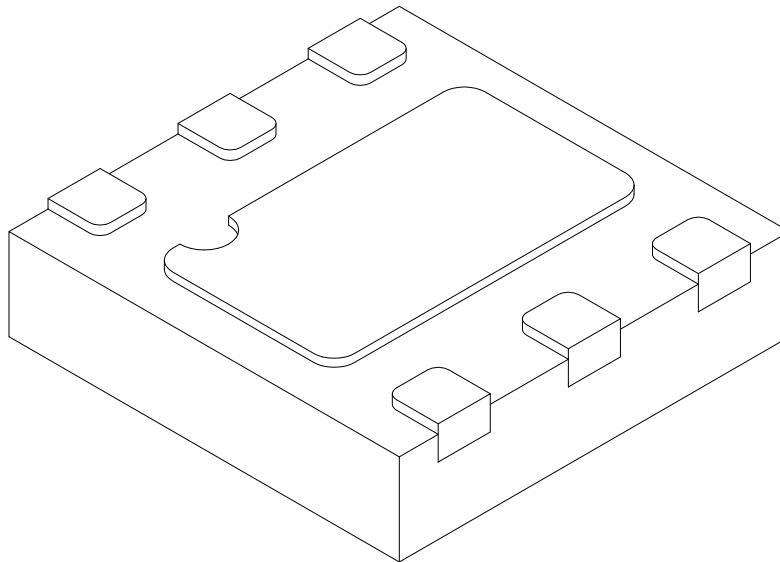

		Units	MILLIMETERS		
		Dimension Limits	MIN	NOM	MAX
Number of Terminals	N	6			
Pitch	e	0.50 BSC			
Overall Height	A	0.30	0.35	0.40	
Standoff	A1	0.00	0.02	0.05	
Terminal Thickness	A3	0.127 REF			
Overall Width	E	1.50 BSC			
Exposed Pad Width	E2	0.65	0.70	0.75	
Overall Length	D	1.50 BSC			
Exposed Pad Length	D2	1.15	1.20	1.25	
Terminal Width	b	0.15	0.20	0.25	
Terminal Length	L	0.150	0.200	0.250	
Terminal-to-Exposed-Pad	K	0.20	-	-	

**Notes:**

1. Pin 1 visual index feature may vary, but must be located within the hatched area.
2. Package is saw singulated
3. Dimensioning and tolerancing per ASME Y14.5M
  - BSC: Basic Dimension. Theoretically exact value shown without tolerances.
  - REF: Reference Dimension, usually without tolerance, for information purposes only.

**Package Outlines and Dimensions**

**8-Lead Plastic Super-Thin Dual Small Outline No-Lead (8X) - 1.5x1.5 mm Body [X2SON] With 1.2x0.7 mm Exposed Pad**

**Note:** For the most current package drawings, please see the Microchip Packaging Specification located at <http://www.microchip.com/packaging>

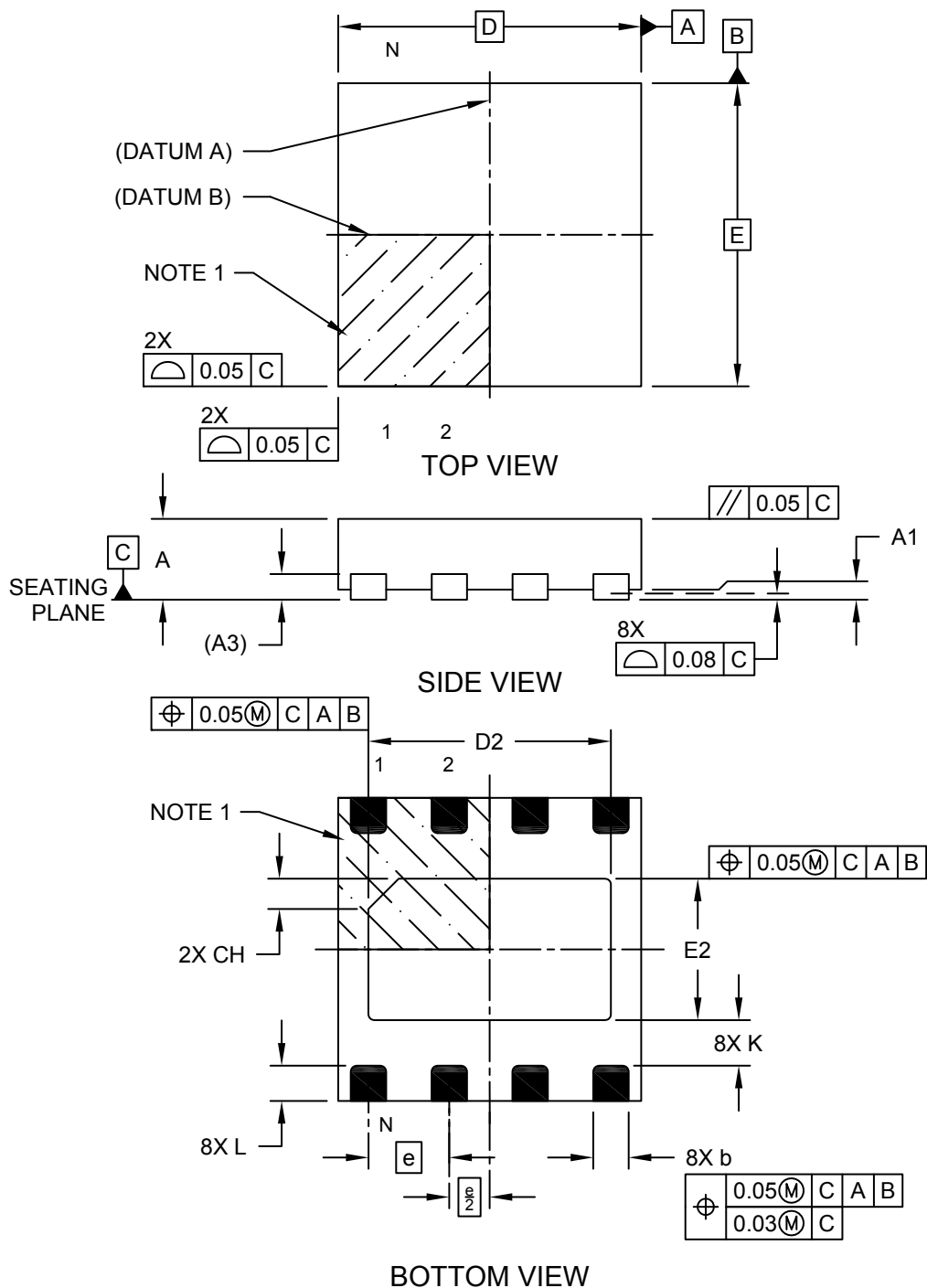

---



---

## Package Outlines and Dimensions

---



---

### 8-Lead Plastic Super-Thin Dual Small Outline No-Lead (8X) - 1.5x1.5 mm Body [X2SON] With 1.2x0.7 mm Exposed Pad

**Note:** For the most current package drawings, please see the Microchip Packaging Specification located at <http://www.microchip.com/packaging>

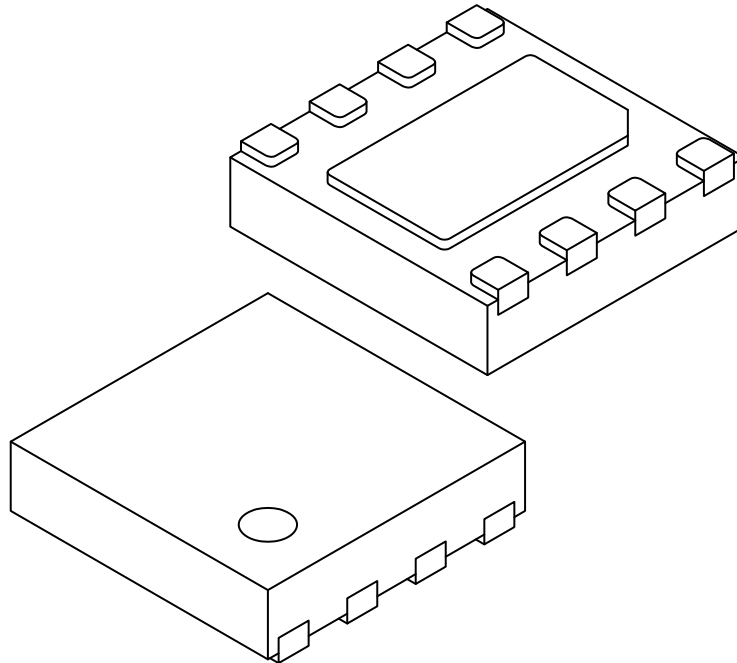

		Units	MILLIMETERS		
Dimension Limits			MIN	NOM	MAX
Number of Terminals	N		8		
Pitch	e		0.40 BSC		
Overall Height	A	0.30	0.35	0.40	
Standoff	A1	0.00	0.02	0.05	
Terminal Thickness	A3	0.127 REF			
Overall Width	E	1.50 BSC			
Exposed Pad Width	E2	0.65	0.70	0.75	
Overall Length	D	1.50 BSC			
Exposed Pad Length	D2	1.15	1.20	1.25	
Exposed Pad Corner Chamfer	CH	-	0.15	-	
Terminal Width	b	0.125	0.175	0.225	
Terminal Length	L	0.125	0.175	0.225	
Terminal-to-Exposed-Pad	K	0.20	-	-	

**Notes:**

1. Pin 1 visual index feature may vary, but must be located within the hatched area.
2. Package is saw singulated
3. Dimensioning and tolerancing per ASME Y14.5M
  - BSC: Basic Dimension. Theoretically exact value shown without tolerances.
  - REF: Reference Dimension, usually without tolerance, for information purposes only.

**Footprint Outlines and Dimensions**

**8-Lead Plastic Super-Thin Dual Small Outline No-Lead (8X) - 1.5x1.5 mm Body [X2SON] With 1.2x0.7 mm Exposed Pad**

**Note:** For the most current package drawings, please see the Microchip Packaging Specification located at <http://www.microchip.com/packaging>

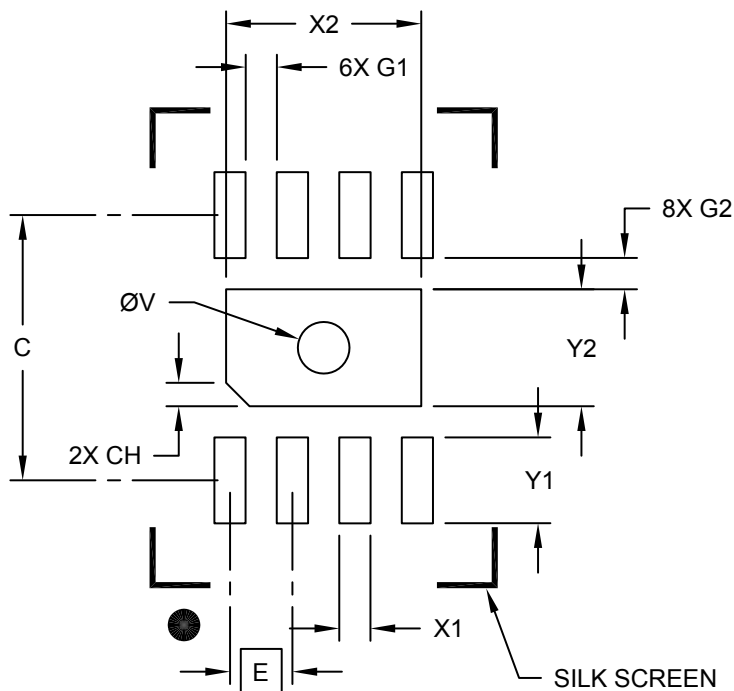

**RECOMMENDED LAND PATTERN**

Dimension Limits	Units	MILLIMETERS		
		MIN	NOM	MAX
Contact Pitch	E	0.40 BSC		
Optional Center Pad Width	X2			1.25
Optional Center Pad Length	Y2			0.75
Optional Center Pad Chamfer (X2)	CH		0.15	
Contact Pad Spacing	C		1.70	
Contact Pad Width (X8)	X1			0.20
Contact Pad Length (X8)	Y1			0.55
Contact Pad to Pad (X6)	G1	0.20		
Contact Pad to Center Pad (X8)	G2	0.20		
Thermal Via Diameter	V		0.33	

**Notes:**

1. Dimensioning and tolerancing per ASME Y14.5M  
BSC: Basic Dimension. Theoretically exact value shown without tolerances.
2. For best soldering results, thermal vias, if used, should be filled or tented to avoid solder loss during reflow process



**Package Outlines and Dimensions**

**8-Terminal Super-Thin Plastic Small Outline, No Lead Package (NR) - 2x2x0.4 mm (Max) Body [X2SON]**

**Note:** For the most current package drawings, please see the Microchip Packaging Specification located at <http://www.microchip.com/packaging>

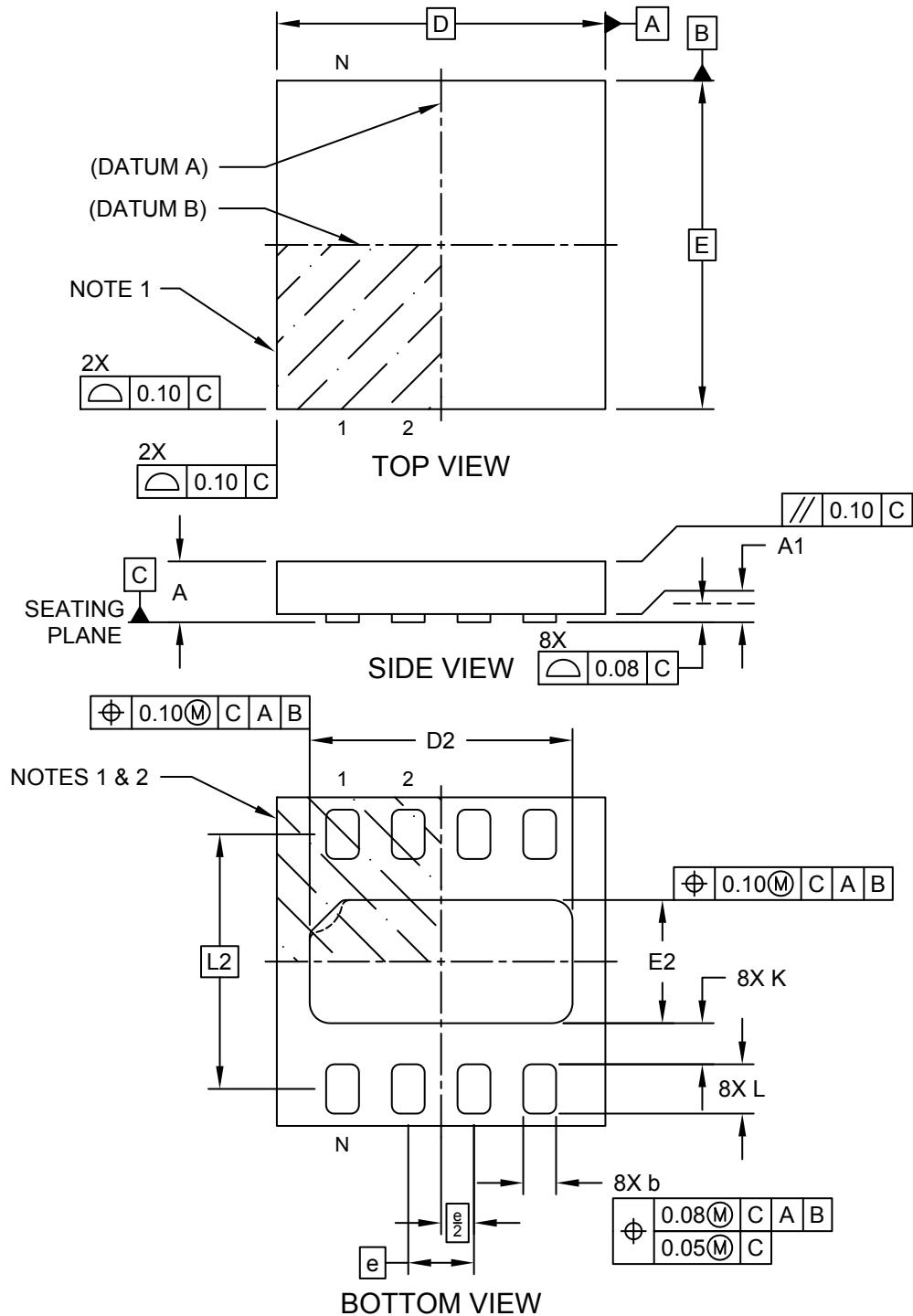

**Package Outlines and Dimensions**

**8-Terminal Super-Thin Plastic Small Outline, No Lead Package (NR) - 2x2x0.4 mm (Max) Body [X2SON]**

**Note:** For the most current package drawings, please see the Microchip Packaging Specification located at <http://www.microchip.com/packaging>

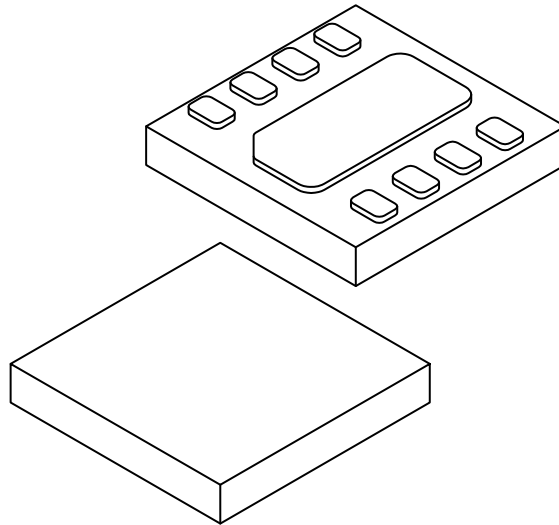

Units		MILLIMETERS		
Dimension Limits		MIN	NOM	MAX
Number of Terminals	N	8		
Pitch	e	0.40 BSC		
Overall Height	A	0.34	0.37	0.40
Standoff	A1	0.00	0.02	0.05
Overall Width	E	2.00 BSC		
Exposed Pad Width	E2	0.70	0.75	0.80
Overall Length	D	2.00 BSC		
Exposed Pad Length	D2	1.55	1.60	1.65
Terminal Width	b	0.15	0.20	0.25
Terminal Length	L	0.25	0.30	0.35
Terminal Center-to-Center	L2	1.55 BSC		
Terminal-to-Exposed-Pad	K	0.20	-	-

**Notes:**

1. Pin 1 visual index feature may vary, but must be located within the hatched area.
2. Pin 1 index on exposed pad may be curved indentation or 45° chamfer
3. Package is saw singulated
4. Dimensioning and tolerancing per ASME Y14.5M

BSC: Basic Dimension. Theoretically exact value shown without tolerances.

REF: Reference Dimension, usually without tolerance, for information purposes only.

---



---

## Footprint Outlines and Dimensions

---



---

### 8-Terminal Super-Thin, No Lead Package (NR) - 2x2x0.4 mm (Max) Body [X2SON]

**Note:** For the most current package drawings, please see the Microchip Packaging Specification located at <http://www.microchip.com/packaging>

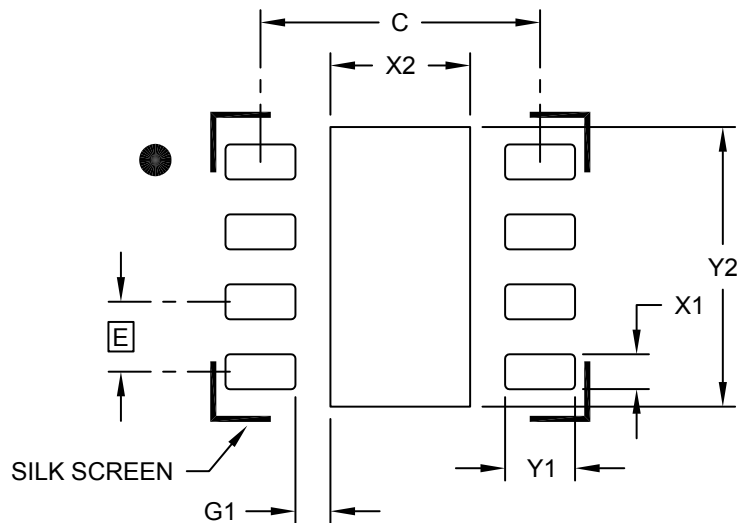

### RECOMMENDED LAND PATTERN

Dimension Limits	Units	MILLIMETERS		
		MIN	NOM	MAX
Contact Pitch	E	0.40 BSC		
Optional Center Pad Width	X2			0.80
Optional Center Pad Length	Y2			1.60
Contact Pad Spacing	C	1.60		
Contact Pad Width (X8)	X1			0.20
Contact Pad Length (X8)	Y1			0.40
Contact Pad to Center Pad (X8)	G1	0.20		

**Notes:**

1. Dimensioning and tolerancing per ASME Y14.5M

BSC: Basic Dimension. Theoretically exact value shown without tolerances.

Microchip Technology Drawing C04-2201-NR-A

**Package Outlines and Dimensions**

**8-Terminal Super-Thin Plastic Small Outline, No Lead Package (XX8E) - 2x2x0.4 mm (Max) Body [X2SON]**

**Note:** For the most current package drawings, please see the Microchip Packaging Specification located at <http://www.microchip.com/packaging>

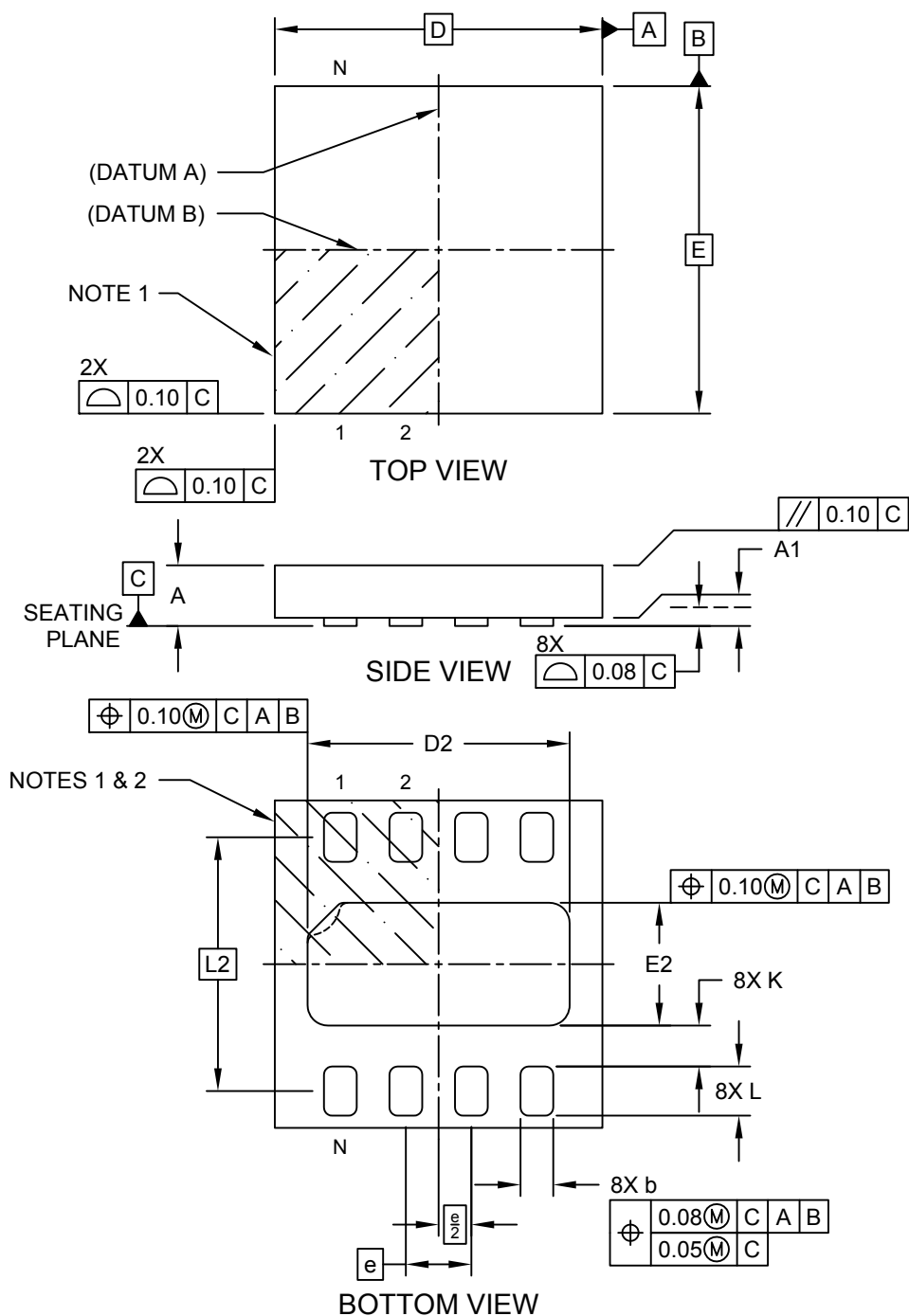

Microchip Technology Drawing C04-201-XX8E-A Sheet 1 of 2

---



---

## Package Outlines and Dimensions

---



---

### 8-Terminal Super-Thin Plastic Small Outline, No Lead Package (XX8E) - 2x2x0.4 mm (Max) Body [X2SON]

**Note:** For the most current package drawings, please see the Microchip Packaging Specification located at <http://www.microchip.com/packaging>

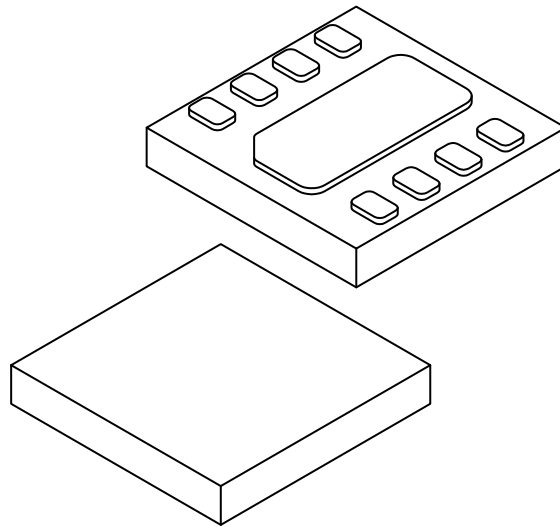

Units		MILLIMETERS		
		MIN	NOM	MAX
Dimension Limits				
Number of Terminals	N	8		
Pitch	e	0.40 BSC		
Overall Height	A	0.34	0.37	0.40
Standoff	A1	0.00	0.02	0.05
Overall Width	E	2.00 BSC		
Exposed Pad Width	E2	0.70	0.75	0.80
Overall Length	D	2.00 BSC		
Exposed Pad Length	D2	1.55	1.60	1.65
Terminal Width	b	0.15	0.20	0.25
Terminal Length	L	0.25	0.30	0.35
Terminal Center-to-Center	L2	1.55 BSC		
Terminal-to-Exposed-Pad	K	0.20	-	-

**Notes:**

1. Pin 1 visual index feature may vary, but must be located within the hatched area.
2. Pin 1 index on exposed pad may be curved indentation or 45° chamfer
3. Package is saw singulated
4. Dimensioning and tolerancing per ASME Y14.5M

BSC: Basic Dimension. Theoretically exact value shown without tolerances.

REF: Reference Dimension, usually without tolerance, for information purposes only.

**Footprint Outlines and Dimensions**

**8-Terminal Super-Thin, No Lead Package (XX8E) - 2x2x0.4 mm (Max) Body [X2SON]**

**Note:** For the most current package drawings, please see the Microchip Packaging Specification located at <http://www.microchip.com/packaging>

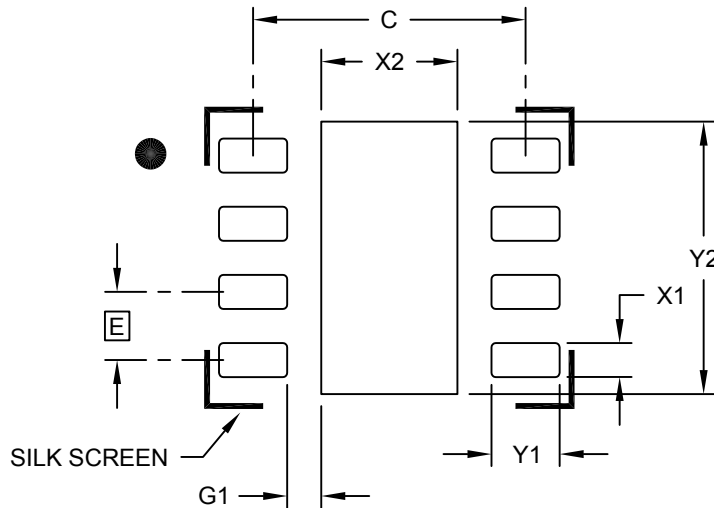

**RECOMMENDED LAND PATTERN**

Units		MILLIMETERS		
Dimension Limits		MIN	NOM	MAX
Contact Pitch	E	0.40 BSC		
Optional Center Pad Width	X2			0.80
Optional Center Pad Length	Y2			1.60
Contact Pad Spacing	C		1.60	
Contact Pad Width (X8)	X1			0.20
Contact Pad Length (X8)	Y1			0.40
Contact Pad to Center Pad (X8)	G1	0.20		

**Notes:**

1. Dimensioning and tolerancing per ASME Y14.5M

BSC: Basic Dimension. Theoretically exact value shown without tolerances.

Microchip Technology Drawing C04-2201-XX8E-A

---

---

**Package Outlines and Dimensions**

---

---

**QFN**

**Package Outlines and Dimensions**

**16-Lead Plastic Quad Flat, No Lead Package (NG) - 3x3x0.9 mm Body [QFN]**

**Note:** For the most current package drawings, please see the Microchip Packaging Specification located at <http://www.microchip.com/packaging>

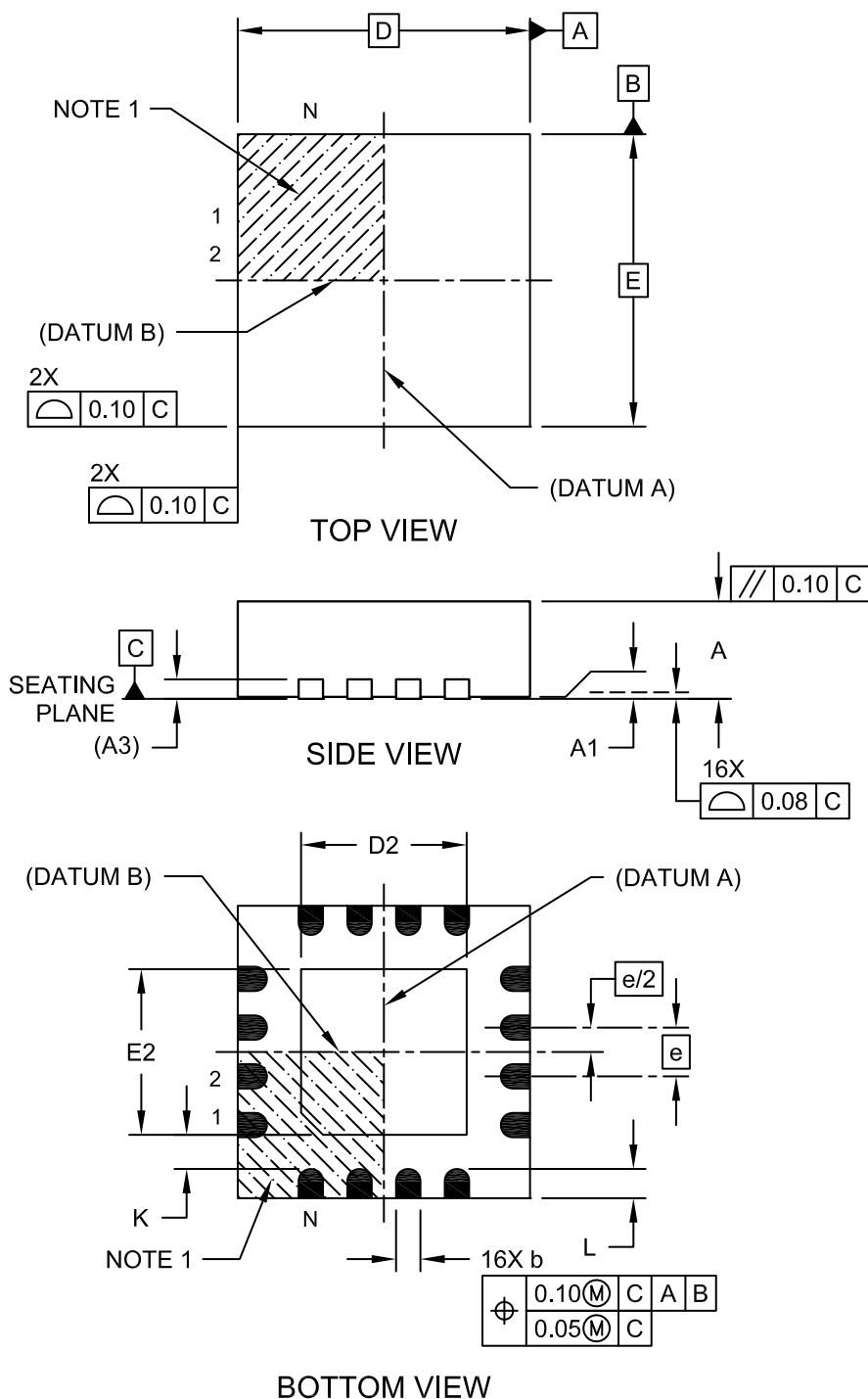



---



---

## Package Outlines and Dimensions

---



---

### 16-Lead Plastic Quad Flat, No Lead Package (NG) - 3x3x0.9 mm Body [QFN]

**Note:** For the most current package drawings, please see the Microchip Packaging Specification located at <http://www.microchip.com/packaging>

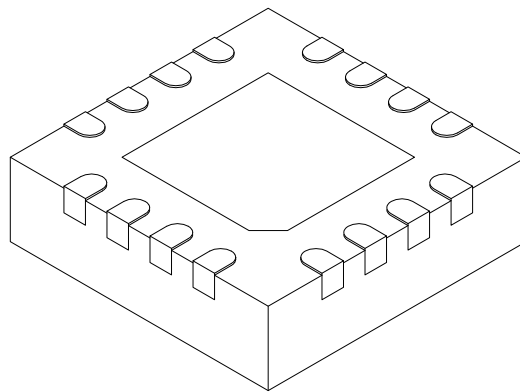

		Units		MILLIMETERS		
Dimension Limits		MIN	NOM	MAX		
Number of Pins	N	16				
Pitch	e	0.50 BSC				
Overall Height	A	0.80	0.90	1.00		
Standoff	A1	0.00	0.02	0.05		
Terminal Thickness	A3	0.20 REF				
Overall Width	E	3.00 BSC				
Exposed Pad Width	E2	1.55	1.70	1.80		
Overall Length	D	3.00 BSC				
Exposed Pad Length	D2	1.55	1.70	1.80		
Terminal Width	b	0.18	0.25	0.30		
Terminal Length	L	0.20	0.30	0.40		
Terminal-to-Exposed Pad	K	0.20	-	-		

**Notes:**

1. Pin 1 visual index feature may vary, but must be located within the hatched area.
2. Package is saw singulated.
3. Dimensioning and tolerancing per ASME Y14.5M.
  - BSC: Basic Dimension. Theoretically exact value shown without tolerances.
  - REF: Reference Dimension, usually without tolerance, for information purposes only.

**Footprint Outlines and Dimensions**

16-Lead Plastic Quad Flat, No Lead Package (NG) – 3x3x0.9 mm Body [QFN]

**Note:** For the most current package drawings, please see the Microchip Packaging Specification located at <http://www.microchip.com/packaging>

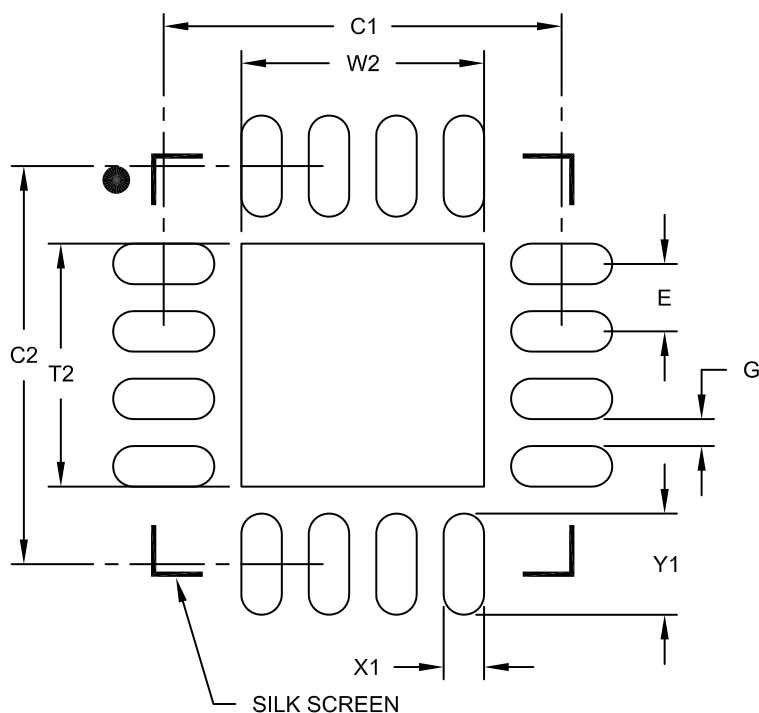

RECOMMENDED LAND PATTERN

Dimension Limits	Units	MILLIMETERS		
		MIN	NOM	MAX
Contact Pitch	E	0.50 BSC		
Optional Center Pad Width	W2			1.80
Optional Center Pad Length	T2			1.80
Contact Pad Spacing	C1		2.95	
Contact Pad Spacing	C2		2.95	
Contact Pad Width (X16)	X1			0.30
Contact Pad Length (X16)	Y1			0.75
Distance Between Pads	G	0.20		

Notes:

1. Dimensioning and tolerancing per ASME Y14.5M

BSC: Basic Dimension. Theoretically exact value shown without tolerances.

Microchip Technology Drawing No. C04-2197A

**Package Outlines and Dimensions**

**16-Lead Plastic Quad Flat, No Lead Package (MG) - 3x3x0.9 mm Body [QFN]**

**Note:** For the most current package drawings, please see the Microchip Packaging Specification located at <http://www.microchip.com/packaging>

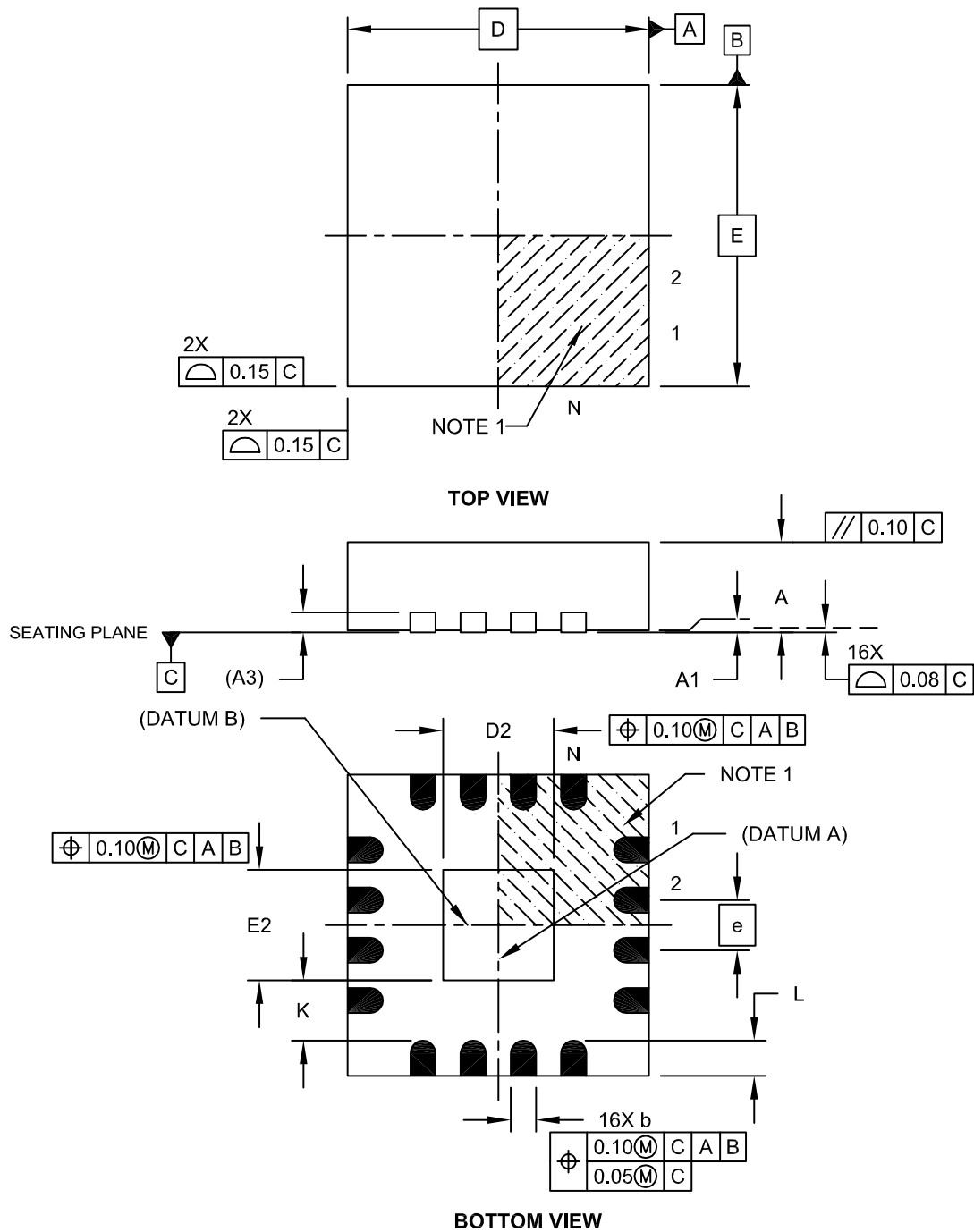

**Package Outlines and Dimensions**

**16-Lead Plastic Quad Flat, No Lead Package (MG) - 3x3x0.9 mm Body [QFN]**

**Note:** For the most current package drawings, please see the Microchip Packaging Specification located at <http://www.microchip.com/packaging>

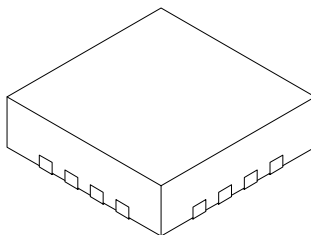

Dimension Limits	Units	MILLIMETERS		
		MIN	NOM	MAX
Number of Pins	N	16		
Pitch	e	0.50 BSC		
Overall Height	A	0.80	0.85	0.90
Standoff	A1	0.00	0.02	0.05
Contact Thickness	A3	0.20 REF		
Overall Width	E	3.00 BSC		
Exposed Pad Width	E2	1.00	1.10	1.50
Overall Length	D	3.00 BSC		
Exposed Pad Length	D2	1.00	1.10	1.50
Contact Width	b	0.18	0.25	0.30
Contact Length	L	0.25	0.35	0.45
Contact-to-Exposed Pad	K	0.20	-	-

**Notes:**

1. Pin 1 visual index feature may vary, but must be located within the hatched area.
2. Package is saw singulated.
3. Dimensioning and tolerancing per ASME Y14.5M.

BSC: Basic Dimension. Theoretically exact value shown without tolerances.

REF: Reference Dimension, usually without tolerance, for information purposes only.

---



---

## Footprint Outlines and Dimensions

---



---

### 16-Lead Plastic Quad Flat, No Lead Package (MG) – 3x3x0.9 mm Body [QFN]

**Note:** For the most current package drawings, please see the Microchip Packaging Specification located at <http://www.microchip.com/packaging>

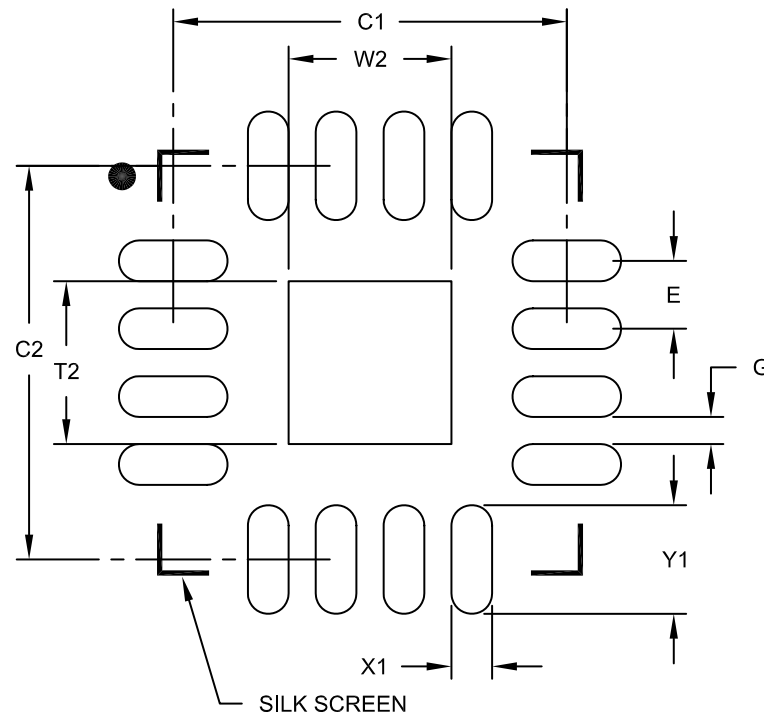

**RECOMMENDED LAND PATTERN**

Dimension Limits	Units	MILLIMETERS		
		MIN	NOM	MAX
Contact Pitch	E	0.50 BSC		
Optional Center Pad Width	W2			1.20
Optional Center Pad Length	T2			1.20
Contact Pad Spacing	C1		2.90	
Contact Pad Spacing	C2		2.90	
Contact Pad Width (X16)	X1			0.30
Contact Pad Length (X16)	Y1			0.80
Distance Between Pads	G	0.20		

**Notes:**

1. Dimensioning and tolerancing per ASME Y14.5M

BSC: Basic Dimension. Theoretically exact value shown without tolerances.

Microchip Technology Drawing No. C04-2142A

**Package Outlines and Dimensions**

**16-Lead Plastic Quad Flat, No Lead Package (ML) - 4x4x0.9mm Body [QFN]**

**Note:** For the most current package drawings, please see the Microchip Packaging Specification located at <http://www.microchip.com/packaging>

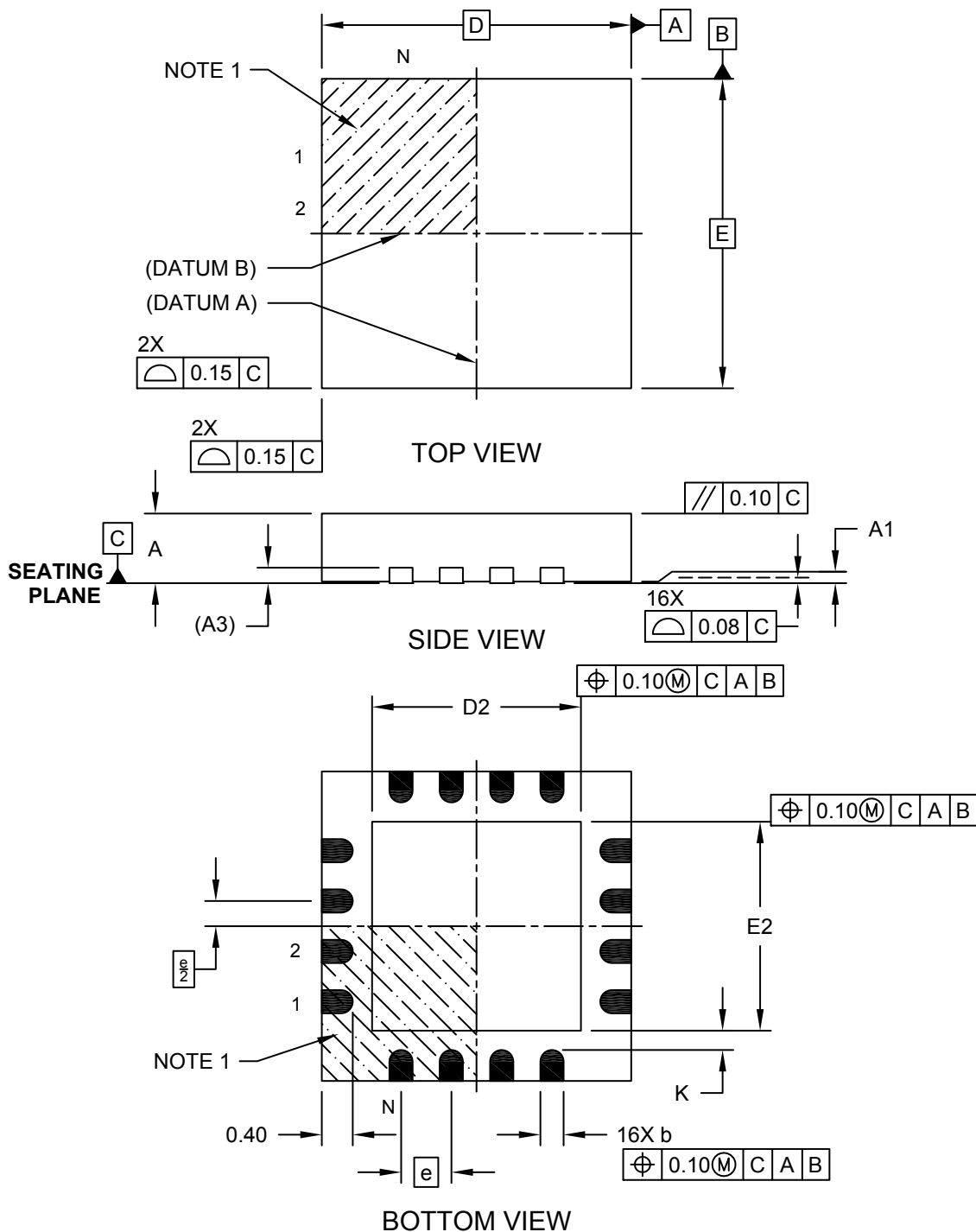

---



---

## Package Outlines and Dimensions

---



---

### 16-Lead Plastic Quad Flat, No Lead Package (ML) - 4x4x0.9mm Body [QFN]

**Note:** For the most current package drawings, please see the Microchip Packaging Specification located at <http://www.microchip.com/packaging>

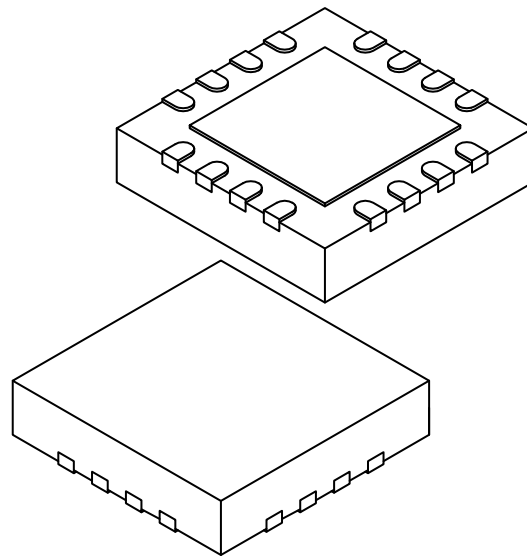

Dimension Limits	Units	MILLIMETERS		
		MIN	NOM	MAX
Number of Pins	N	16		
Pitch	e	0.65 BSC		
Overall Height	A	0.80	0.90	1.00
Standoff	A1	0.00	0.02	0.05
Contact Thickness	A3	0.20 REF		
Overall Width	E	4.00 BSC		
Exposed Pad Width	E2	2.50	2.65	2.80
Overall Length	D	4.00 BSC		
Exposed Pad Length	D2	2.50	2.65	2.80
Contact Width	b	0.25	0.30	0.35
Contact Length	L	0.30	0.40	0.50
Contact-to-Exposed Pad	K	0.20	-	-

**Notes:**

1. Pin 1 visual index feature may vary, but must be located within the hatched area.
2. Package is saw singulated
3. Dimensioning and tolerancing per ASME Y14.5M

BSC: Basic Dimension. Theoretically exact value shown without tolerances.

REF: Reference Dimension, usually without tolerance, for information purposes only.

**Footprint Outlines and Dimensions**

**16-Lead Plastic Quad Flat, No Lead Package (ML) - 4x4x0.9mm Body [QFN]**

**Note:** For the most current package drawings, please see the Microchip Packaging Specification located at <http://www.microchip.com/packaging>

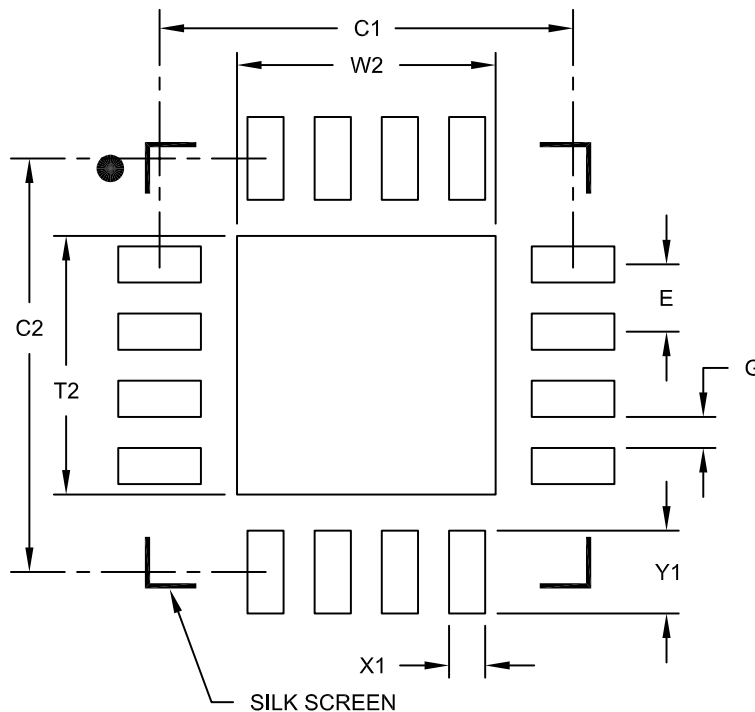

**RECOMMENDED LAND PATTERN**

Dimension Limits	Units	MILLIMETERS		
		MIN	NOM	MAX
Contact Pitch	E	0.65 BSC		
Optional Center Pad Width	W2			2.50
Optional Center Pad Length	T2			2.50
Contact Pad Spacing	C1		4.00	
Contact Pad Spacing	C2		4.00	
Contact Pad Width (X28)	X1			0.35
Contact Pad Length (X28)	Y1			0.80
Distance Between Pads	G	0.30		

**Notes:**

1. Dimensioning and tolerancing per ASME Y14.5M

BSC: Basic Dimension. Theoretically exact value shown without tolerances.

Microchip Technology Drawing No. C04-2127A



**Package Outlines and Dimensions**

**16-Lead Plastic Quad Flat, No Lead Package (8E) - 4x4x0.9 mm Body [QFN]**

**Note:** For the most current package drawings, please see the Microchip Packaging Specification located at <http://www.microchip.com/packaging>

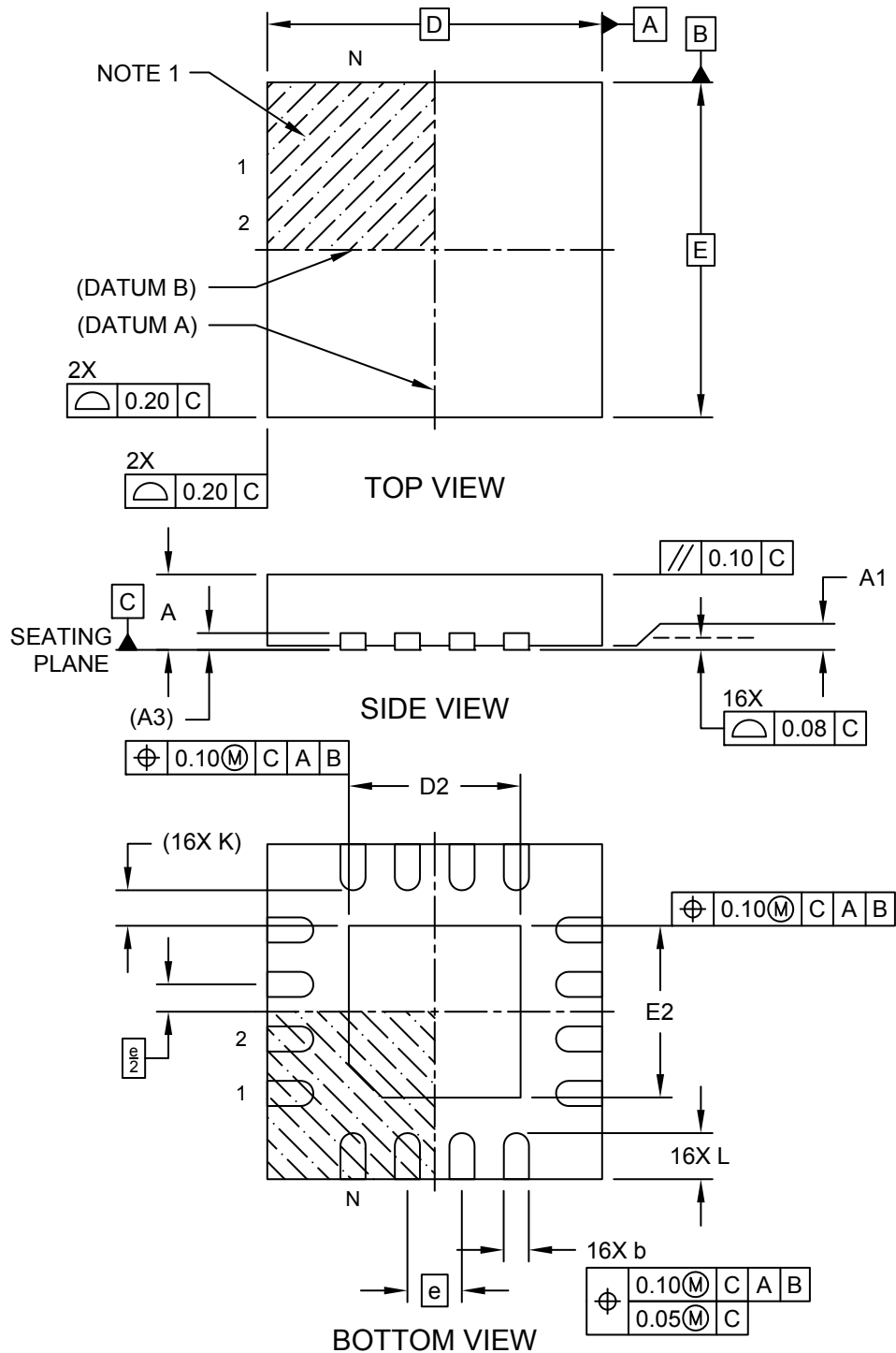

Microchip Technology Drawing C04-259B Sheet 1 of 2

**Package Outlines and Dimensions**

**16-Lead Plastic Quad Flat, No Lead Package (8E) - 4x4x0.9 mm Body [QFN]**

**Note:** For the most current package drawings, please see the Microchip Packaging Specification located at <http://www.microchip.com/packaging>

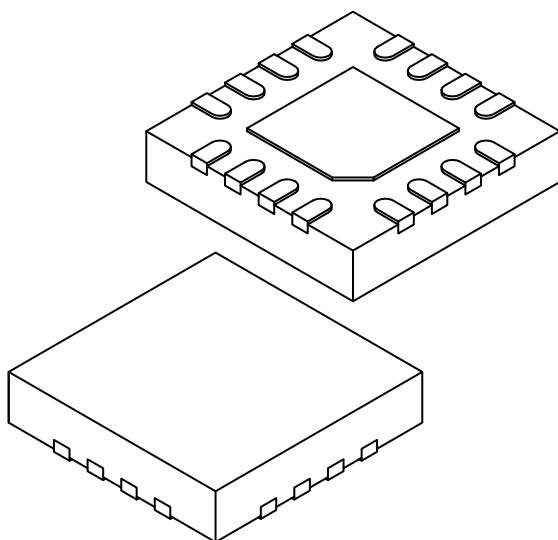

		Units	MILLIMETERS		
Dimension Limits			MIN	NOM	MAX
Number of Pins	N		16		
Pitch	e		0.65 BSC		
Overall Height	A	0.80	0.87	0.95	
Standoff	A1	0.00	0.02	0.05	
Terminal Thickness	A3	0.20 REF			
Overall Width	E	4.00 BSC			
Exposed Pad Width	E2	1.95	2.05	2.15	
Overall Length	D	4.00 BSC			
Exposed Pad Length	D2	1.95	2.05	2.15	
Terminal Width	b	0.25	0.30	0.35	
Terminal Length	L	0.45	0.55	0.65	
Terminal-to-Exposed-Pad	K	0.425 REF			

**Notes:**

1. Pin 1 visual index feature may vary, but must be located within the hatched area.
2. Package is saw singulated
3. Dimensioning and tolerancing per ASME Y14.5M

BSC: Basic Dimension. Theoretically exact value shown without tolerances.

REF: Reference Dimension, usually without tolerance, for information purposes only.

---



---

## Footprint Outlines and Dimensions

---



---

### 16-Lead Plastic Quad Flat, No Lead Package (8E) - 4x4x0.9 mm Body [QFN]

**Note:** For the most current package drawings, please see the Microchip Packaging Specification located at <http://www.microchip.com/packaging>

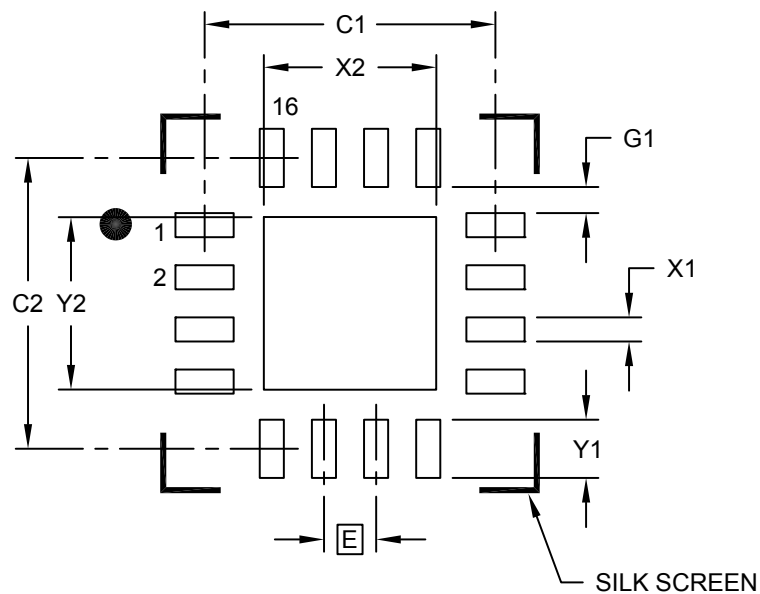

### RECOMMENDED LAND PATTERN

Dimension Limits	Units	MILLIMETERS		
		MIN	NOM	MAX
Contact Pitch	E	0.65 BSC		
Optional Center Pad Width	X2			2.15
Optional Center Pad Length	Y2			2.15
Contact Pad Spacing	C1		3.625	
Contact Pad Spacing	C2		3.625	
Contact Pad Width (X16)	X1			0.30
Contact Pad Length (X16)	Y1			0.725
Contact Pad to Center Pad (X16)	G1	0.20		

**Notes:**

1. Dimensioning and tolerancing per ASME Y14.5M

BSC: Basic Dimension. Theoretically exact value shown without tolerances.

Microchip Technology Drawing C04-2259A

## Package Outlines and Dimensions

### 16-Lead Plastic Quad Flat, No Lead Package (FX) - 4x4x0.9 mm Body [QFN]

**Note:** For the most current package drawings, please see the Microchip Packaging Specification located at <http://www.microchip.com/packaging>

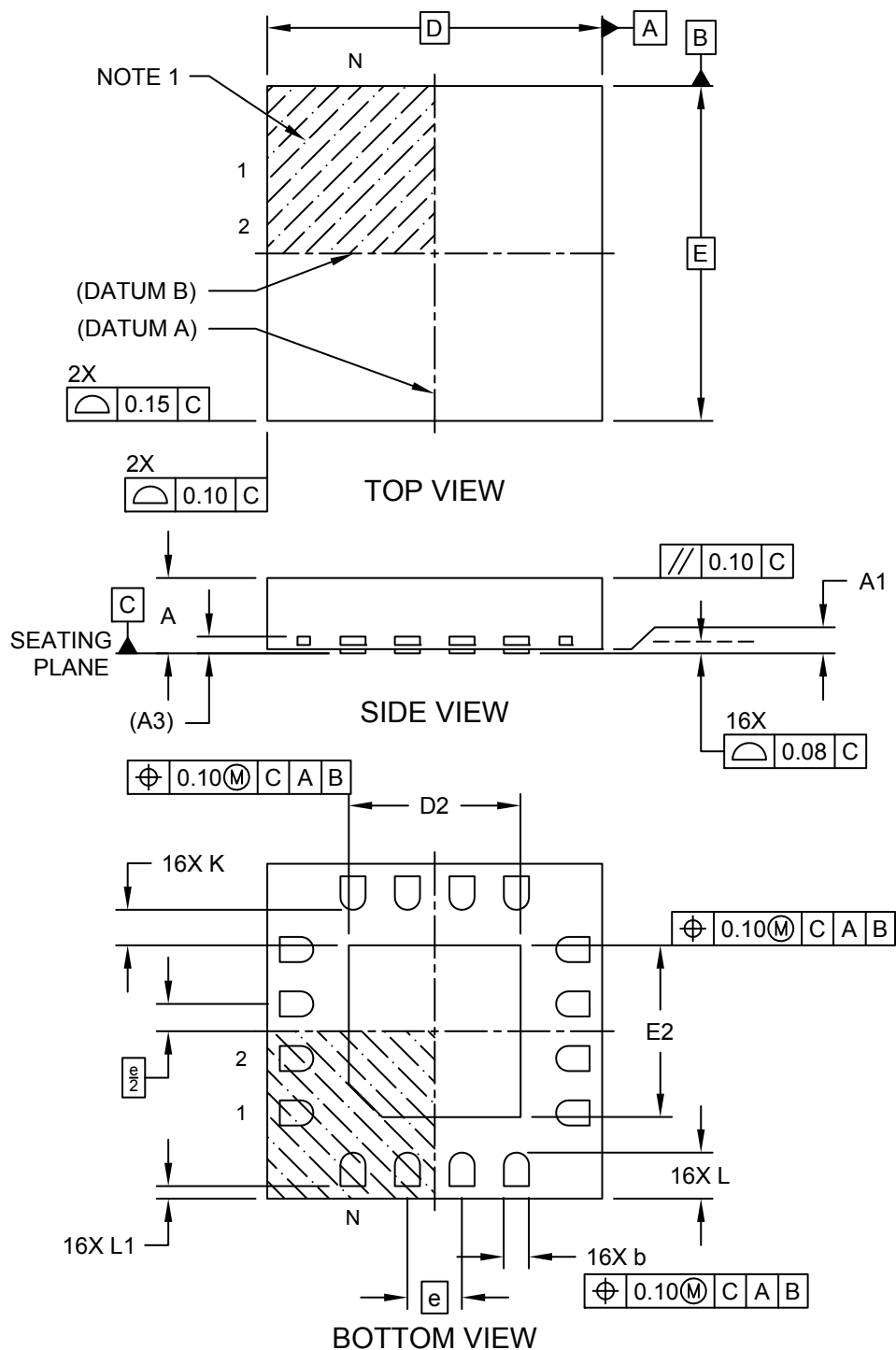

---



---

## Package Outlines and Dimensions

---



---

### 16-Lead Plastic Quad Flat, No Lead Package (FX) - 4x4x0.9 mm Body [QFN]

**Note:** For the most current package drawings, please see the Microchip Packaging Specification located at <http://www.microchip.com/packaging>

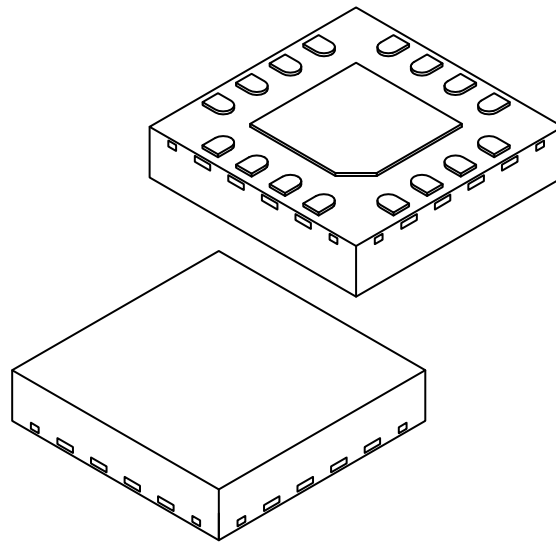

		Units	MILLIMETERS		
Dimension Limits			MIN	NOM	MAX
Number of Pins	N		16		
Pitch	e		0.65 BSC		
Overall Height	A		0.85	0.90	1.00
Standoff	A1		0.00	0.02	0.05
Terminal Thickness	A3		0.20 REF		
Overall Width	E		4.00 BSC		
Exposed Pad Width	E2		1.95	2.05	2.15
Overall Length	D		4.00 BSC		
Exposed Pad Length	D2		1.95	2.05	2.15
Terminal Width	b		0.25	0.30	0.35
Terminal Length	L		0.45	0.55	0.65
Pull Back	L1		—	—	0.15
Terminal-to-Exposed-Pad	K		0.20	—	—

**Notes:**

1. Pin 1 visual index feature may vary, but must be located within the hatched area.
2. Package is saw singulated
3. Dimensioning and tolerancing per ASME Y14.5M

BSC: Basic Dimension. Theoretically exact value shown without tolerances.

REF: Reference Dimension, usually without tolerance, for information purposes only.

**Footprint Outlines and Dimensions**

**16-Lead Plastic Quad Flat, No Lead Package (FX) - 4x4x0.9 mm Body [QFN]**

**Note:** For the most current package drawings, please see the Microchip Packaging Specification located at <http://www.microchip.com/packaging>

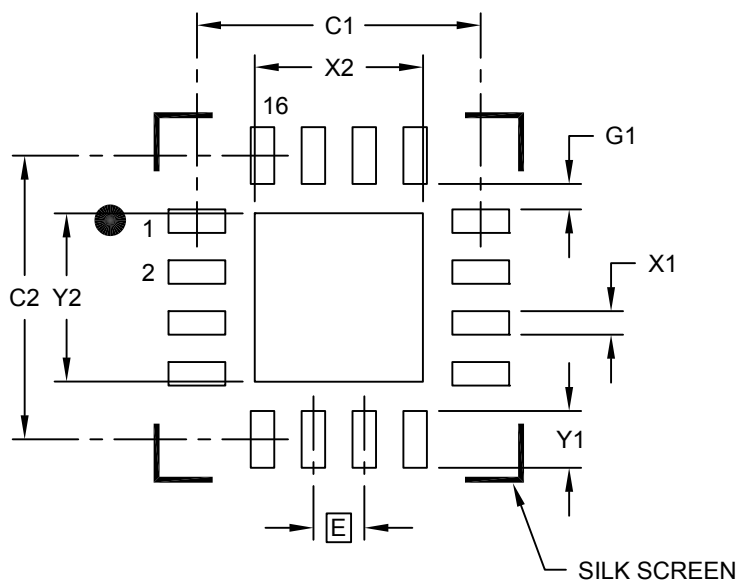

**RECOMMENDED LAND PATTERN**

Dimension Limits	Units	MILLIMETERS		
		MIN	NOM	MAX
Contact Pitch	E	0.65 BSC		
Optional Center Pad Width	X2			2.15
Optional Center Pad Length	Y2			2.15
Contact Pad Spacing	C1		3.625	
Contact Pad Spacing	C2		3.625	
Contact Pad Width (X16)	X1			0.30
Contact Pad Length (X16)	Y1			0.725
Contact Pad to Center Pad (X16)	G1	0.20		

**Notes:**

1. Dimensioning and tolerancing per ASME Y14.5M

BSC: Basic Dimension. Theoretically exact value shown without tolerances.

Microchip Technology Drawing C04-2262A

---



---

## Package Outlines and Dimensions

---



---

### 20-Lead Plastic Quad Flat, No Lead Package (ML) – 4x4x0.9 mm Body [QFN]

**Note:** For the most current package drawings, please see the Microchip Packaging Specification located at <http://www.microchip.com/packaging>

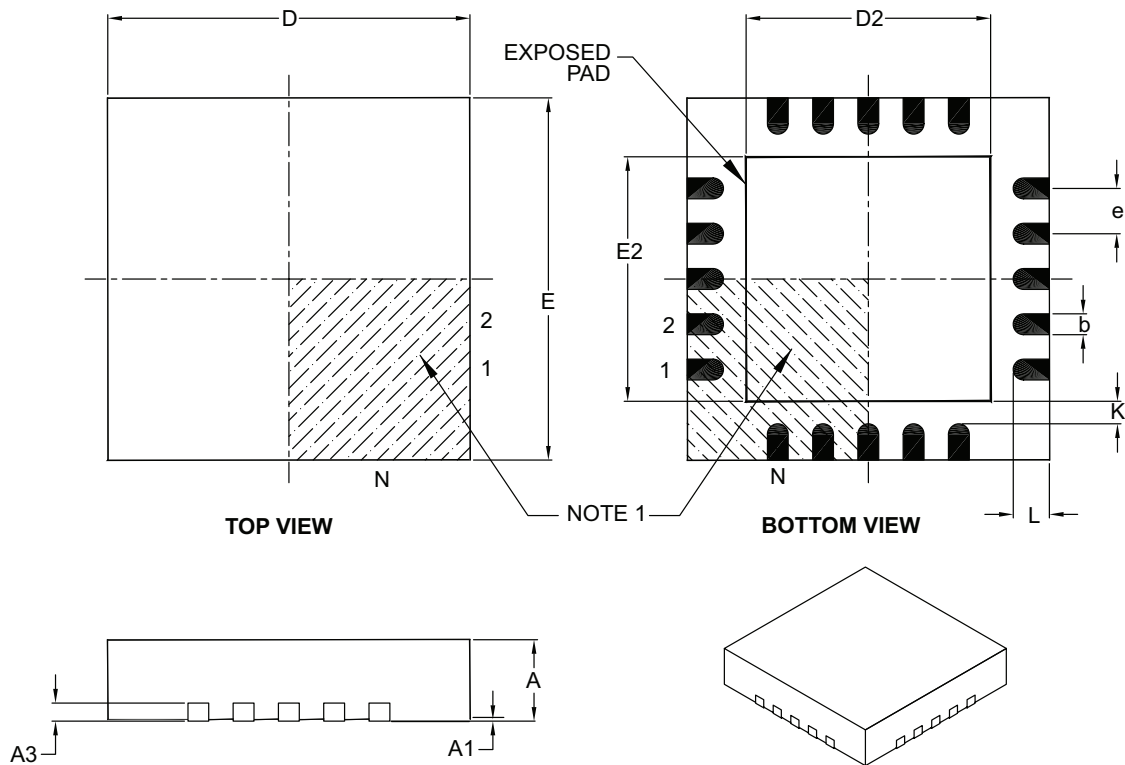

Dimension Limits	Units	MILLIMETERS		
		MIN	NOM	MAX
Number of Pins	N	20		
Pitch	e	0.50 BSC		
Overall Height	A	0.80	0.90	1.00
Standoff	A1	0.00	0.02	0.05
Contact Thickness	A3	0.20 REF		
Overall Width	E	4.00 BSC		
Exposed Pad Width	E2	2.60	2.70	2.80
Overall Length	D	4.00 BSC		
Exposed Pad Length	D2	2.60	2.70	2.80
Contact Width	b	0.18	0.25	0.30
Contact Length	L	0.30	0.40	0.50
Contact-to-Exposed Pad	K	0.20	–	–

**Notes:**

1. Pin 1 visual index feature may vary, but must be located within the hatched area.
2. Package is saw singulated.
3. Dimensioning and tolerancing per ASME Y14.5M.
  - BSC: Basic Dimension. Theoretically exact value shown without tolerances.
  - REF: Reference Dimension, usually without tolerance, for information purposes only.

Microchip Technology Drawing C04-126B

**Footprint Outlines and Dimensions**

20-Lead Plastic Quad Flat, No Lead Package (ML) - 4x4 mm Body [QFN]  
 With 0.40 mm Contact Length

**Note:** For the most current package drawings, please see the Microchip Packaging Specification located at <http://www.microchip.com/packaging>

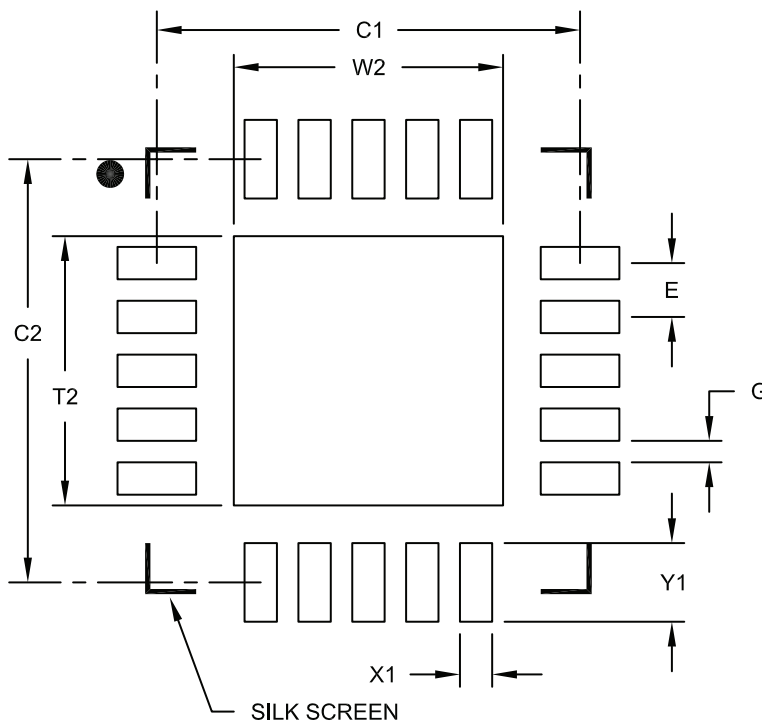

**RECOMMENDED LAND PATTERN**

Dimension Limits	Units	MILLIMETERS		
		MIN	NOM	MAX
Contact Pitch	E	0.50 BSC		
Optional Center Pad Width	W2			2.50
Optional Center Pad Length	T2			2.50
Contact Pad Spacing	C1		3.93	
Contact Pad Spacing	C2		3.93	
Contact Pad Width	X1			0.30
Contact Pad Length	Y1			0.73
Distance Between Pads	G	0.20		

**Notes:**

1. Dimensioning and tolerancing per ASME Y14.5M

BSC: Basic Dimension. Theoretically exact value shown without tolerances.

Microchip Technology Drawing No. C04-2126A



---



---

## Package Outlines and Dimensions

---



---

### 24-Lead Plastic Quad Flat, No Lead Package (MJ) – 4x4x0.9 mm Body [QFN]

**Note:** For the most current package drawings, please see the Microchip Packaging Specification located at <http://www.microchip.com/packaging>

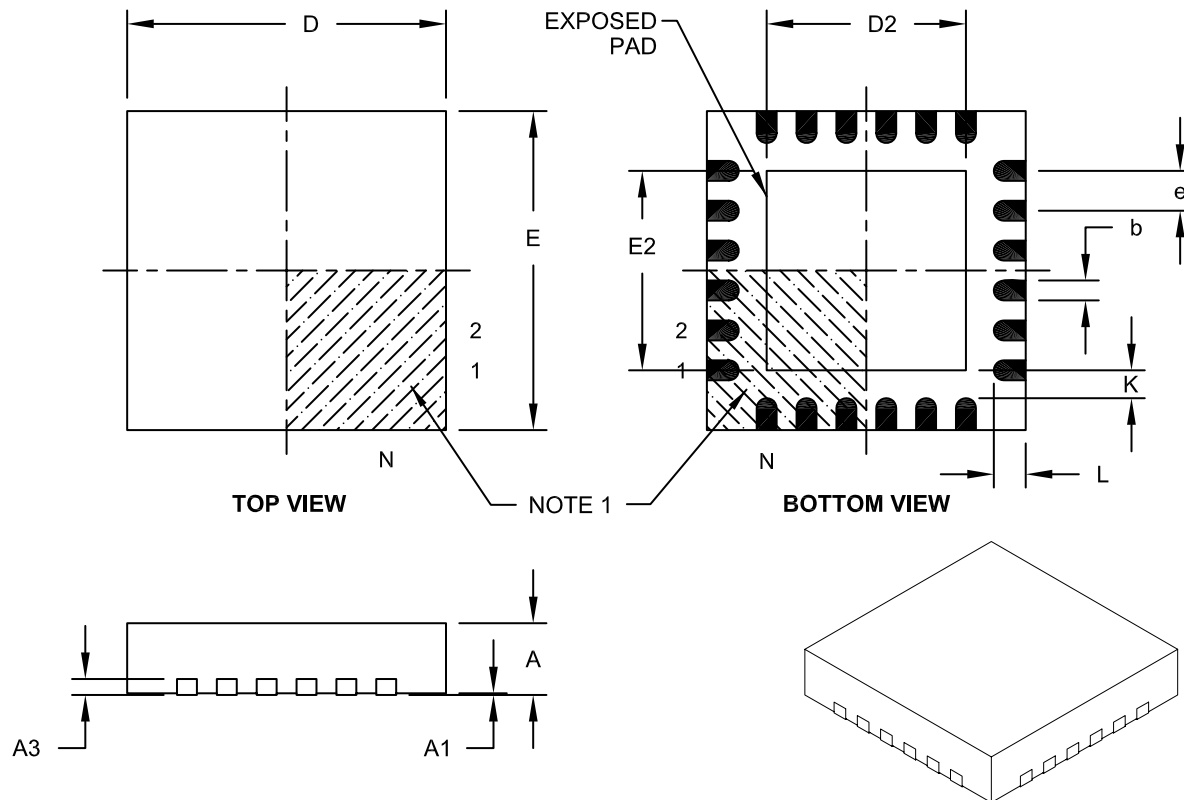

		MILLIMETERS		
Dimension Limits		MIN	NOM	MAX
Number of Pins	N	24		
Pitch	e	0.50 BSC		
Overall Height	A	0.80	0.85	0.90
Standoff	A1	0.00	0.02	0.05
Contact Thickness	A3	0.20 REF		
Overall Width	E	4.00 BSC		
Exposed Pad Width	E2	2.40	2.50	2.60
Overall Length	D	4.00 BSC		
Exposed Pad Length	D2	2.40	2.50	2.60
Contact Width	b	0.20	0.25	0.30
Contact Length	L	0.30	0.40	0.50
Contact-to-Exposed Pad	K	0.20	-	-

**Notes:**

1. Pin 1 visual index feature may vary, but must be located within the hatched area.
2. Package is saw singulated.
3. Dimensioning and tolerancing per ASME Y14.5M.

BSC: Basic Dimension. Theoretically exact value shown without tolerances.

REF: Reference Dimension, usually without tolerance, for information purposes only.

Microchip Technology Drawing C04-143A

**Footprint Outlines and Dimensions**

**24-Lead Plastic Quad Flat, No Lead Package (MJ) - 4x4 mm Body [QFN]**

**Note:** For the most current package drawings, please see the Microchip Packaging Specification located at <http://www.microchip.com/packaging>

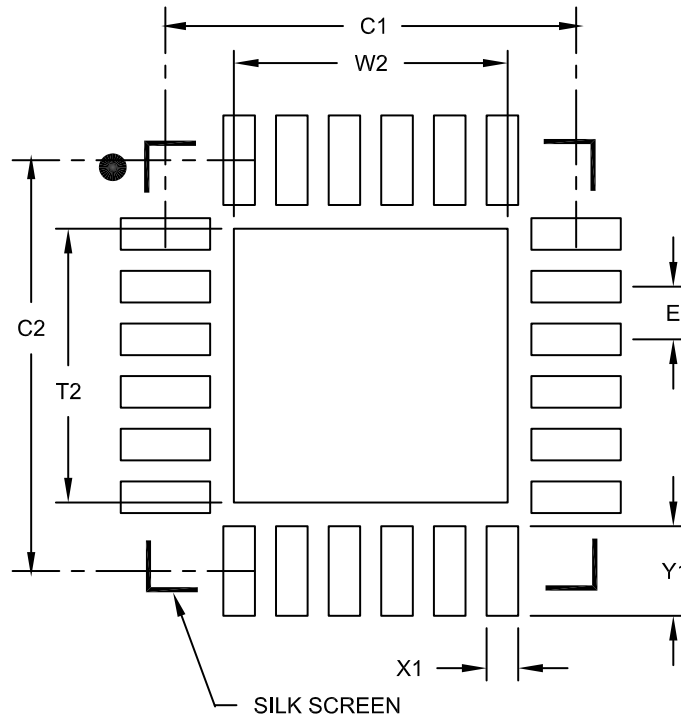

**RECOMMENDED LAND PATTERN**

Dimension Limits	Units	MILLIMETERS		
		MIN	NOM	MAX
Contact Pitch	E	0.50 BSC		
Optional Center Pad Width	W2			2.60
Optional Center Pad Length	T2			2.60
Contact Pad Spacing	C1		3.90	
Contact Pad Spacing	C2		3.90	
Contact Pad Width	X1			0.30
Contact Pad Length	Y1			0.85

**Notes:**

1. Dimensioning and tolerancing per ASME Y14.5M  
BSC: Basic Dimension. Theoretically exact value shown without tolerances.

**Package Outlines and Dimensions**

**24-Lead Plastic Quad Flat, No Lead Package (RU) - 4x4 mm Body [QFN]  
With 2.5x2.5 mm Exposed Pad; Punch Singulated**

**Note:** For the most current package drawings, please see the Microchip Packaging Specification located at <http://www.microchip.com/packaging>

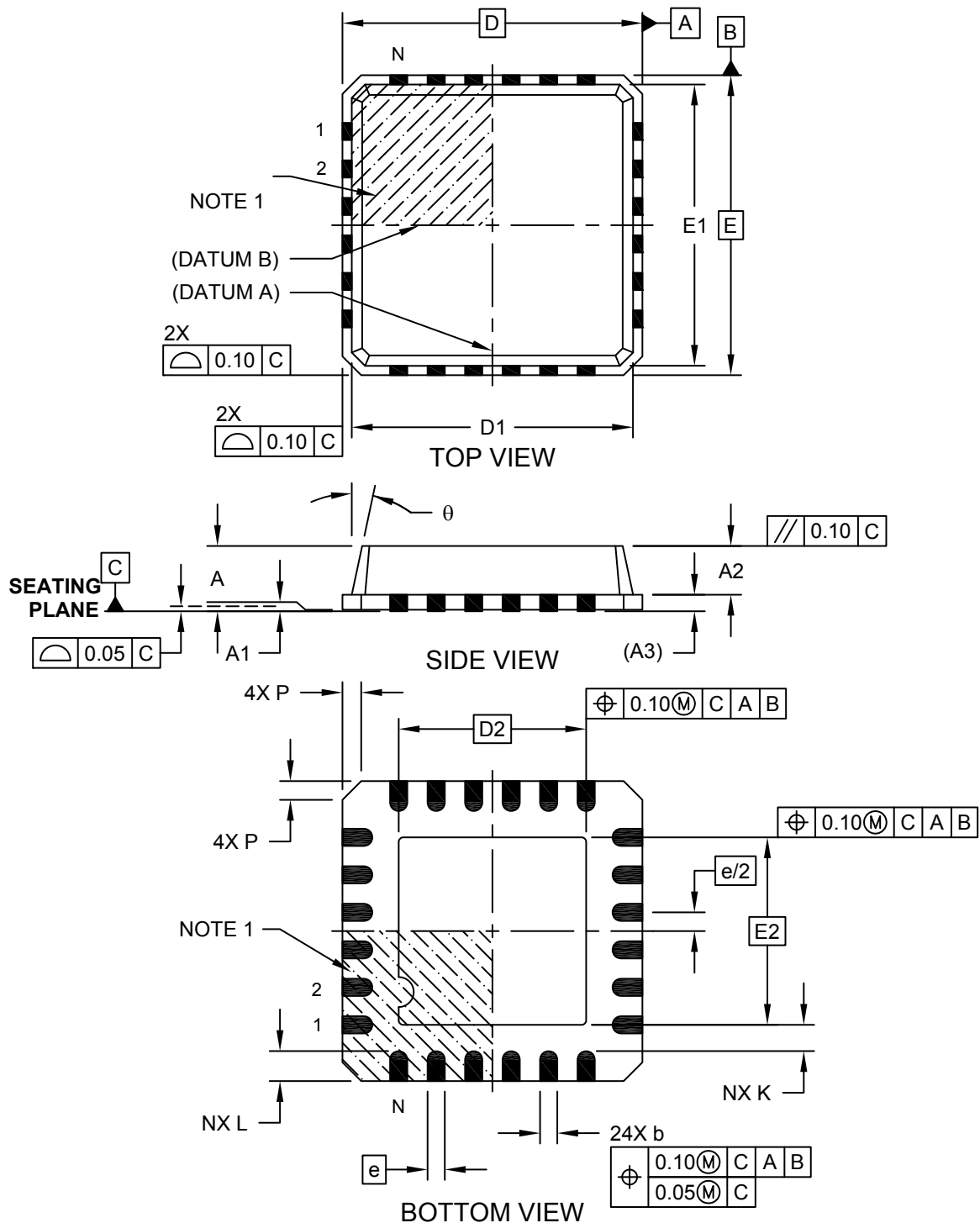

Microchip Technology Drawing C04-225A Sheet 1 of 2

**Package Outlines and Dimensions**

**24-Lead Plastic Quad Flat, No Lead Package (RU) - 4x4 mm Body [QFN]  
With 2.5x2.5 mm Exposed Pad; Punch Singulated**

**Note:** For the most current package drawings, please see the Microchip Packaging Specification located at <http://www.microchip.com/packaging>

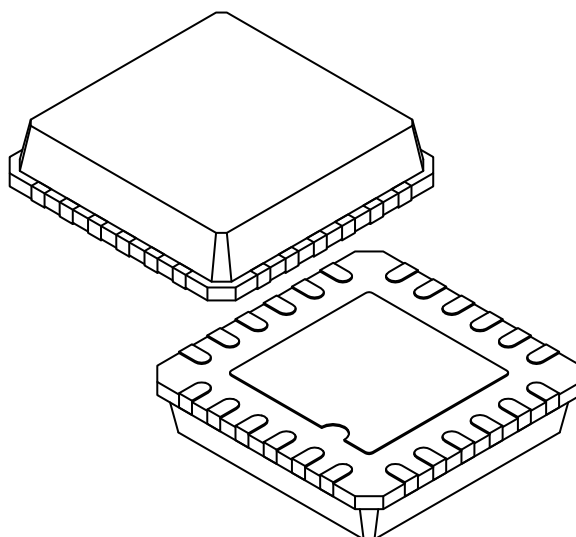

Dimension Limits	Units	MILLIMETERS		
		MIN	NOM	MAX
Number of Pins	N	24		
Pitch	e	0.50 BSC		
Overall Height	A	0.80	0.85	0.90
Standoff	A1	0.00	0.01	0.05
Mold Cap Height	A2	0.60	0.65	0.70
Terminal Thickness	(A3)	0.20 REF		
Overall Width	E	4.00 BSC		
Molded Top Width	E1	3.75 BSC		
Exposed Pad Width	E2	2.40	2.50	2.60
Overall Length	D	4.00 BSC		
Molded Top Length	D1	3.75 BSC		
Exposed Pad Length	D2	2.40	2.50	2.60
Corner Chamfer	P	0.24	0.42	0.60
Terminal Width	b	0.18	0.23	0.30
Terminal Length	L	0.30	0.40	0.50
Terminal-to-Exposed-Pad	K	0.20	-	-
Mold Draft Angle	$\theta$	0°	-	12°

**Notes:**

1. Pin 1 visual index feature may vary, but must be located within the hatched area.
2. Package is punch singulated
3. Dimensioning and tolerancing per ASME Y14.5M

BSC: Basic Dimension. Theoretically exact value shown without tolerances.

REF: Reference Dimension, usually without tolerance, for information purposes only.

---



---

## Footprint Outlines and Dimensions

---



---

### 24-Lead Plastic Quad Flat, No Lead Package (RU) - 4x4 mm Body [QFN] With 2.5x2.5 mm Exposed Pad; Punch Singulated

**Note:** For the most current package drawings, please see the Microchip Packaging Specification located at <http://www.microchip.com/packageing>

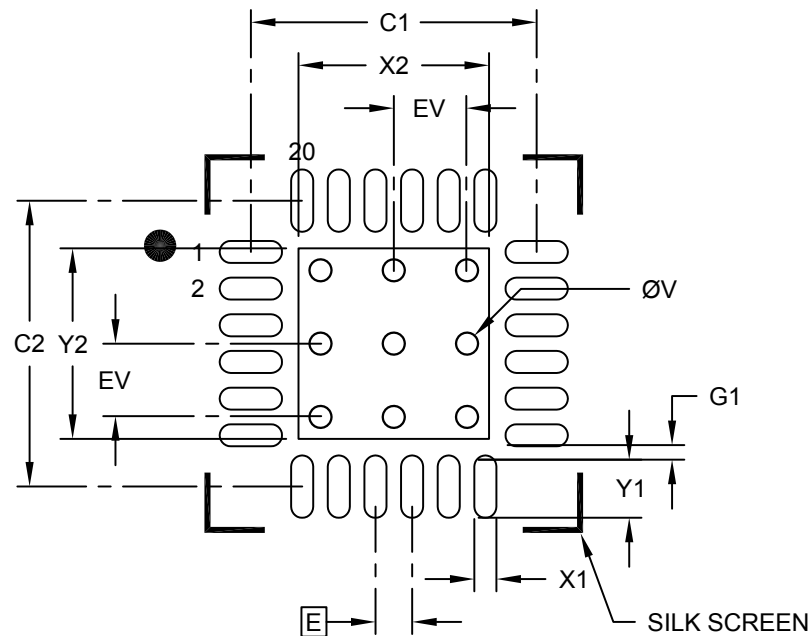

### RECOMMENDED LAND PATTERN

Dimension Limits	Units	MILLIMETERS		
		MIN	NOM	MAX
Contact Pitch	E	0.50 BSC		
Optional Center Pad Width	X2			2.60
Optional Center Pad Length	Y2			2.60
Contact Pad Spacing	C1		3.90	
Contact Pad Spacing	C2		3.90	
Contact Pad Width (X20)	X1			0.30
Contact Pad Length (X20)	Y1			0.85
Contact Pad to Center Pad (X20)	G1	0.20		
Thermal Via Diameter	V		0.30	
Thermal Via Pitch	EV		1.00	

**Notes:**

1. Dimensioning and tolerancing per ASME Y14.5M  
BSC: Basic Dimension. Theoretically exact value shown without tolerances.
2. For best soldering results, thermal vias, if used, should be filled or tented to avoid solder loss during reflow process

Microchip Technology Drawing C04-2225A

**Package Outlines and Dimensions**

**24-Lead Plastic Quad Flat, No Lead Package (LY) – 5x5x1.0 mm Body [QFN or VQFN]**

**Note:** For the most current package drawings, please see the Microchip Packaging Specification located at <http://www.microchip.com/packaging>

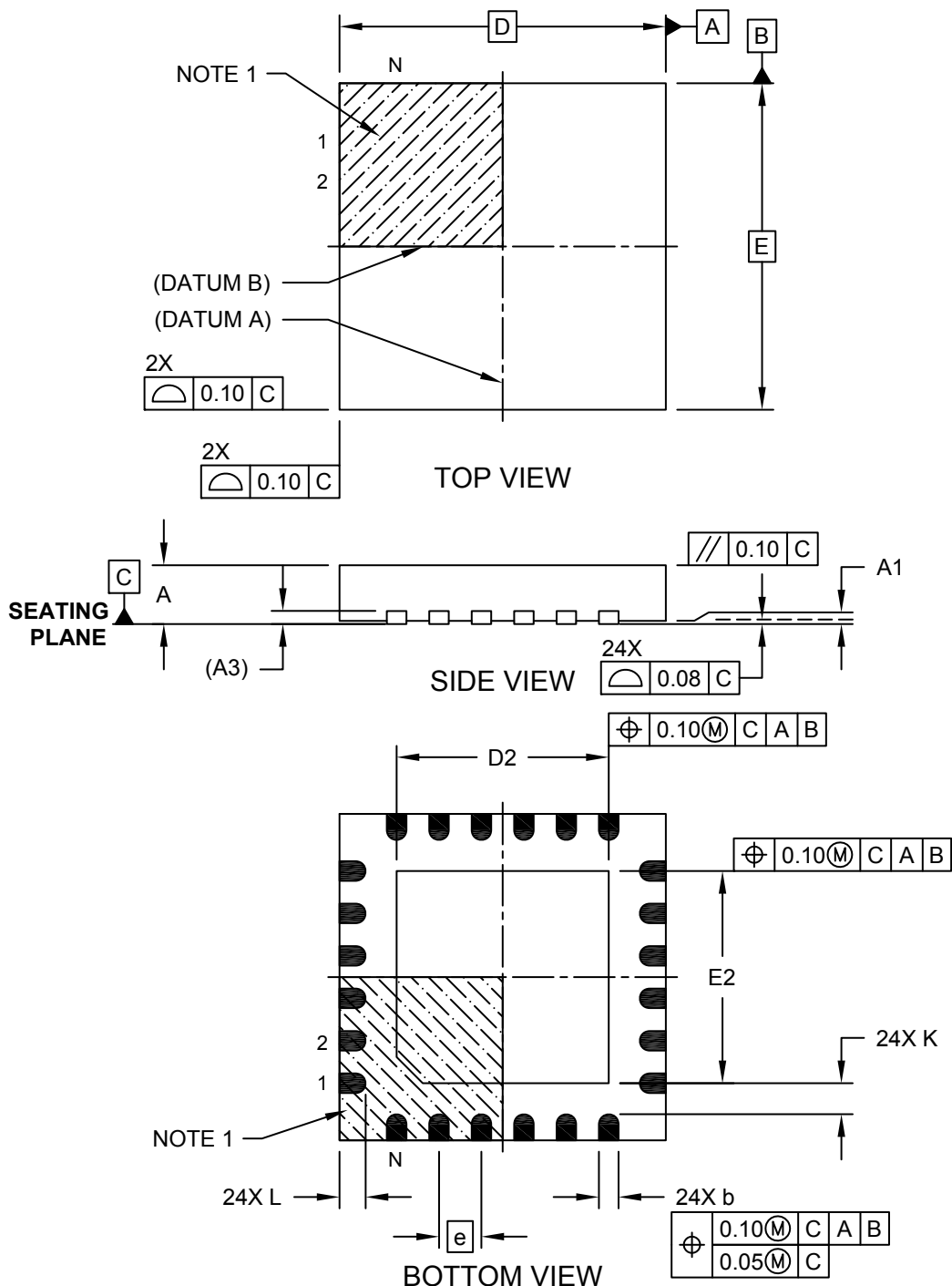

---



---

## Package Outlines and Dimensions

---



---

### 24-Lead Plastic Quad Flat, No Lead Package (LY) – 5x5x1.0 mm Body [QFN or VQFN]

**Note:** For the most current package drawings, please see the Microchip Packaging Specification located at <http://www.microchip.com/packaging>

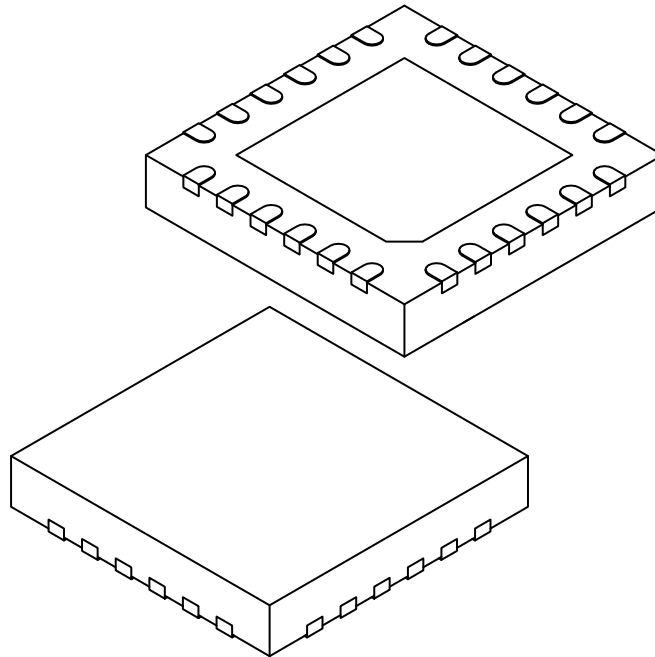

Dimension Limits	Units	MILLIMETERS		
		MIN	NOM	MAX
Number of Terminals	N	24		
Pitch	e	0.65 BSC		
Overall Height	A	0.80	0.90	1.00
Standoff	A1	0.00	0.02	0.05
Terminal Thickness	(A3)	0.20 REF		
Overall Width	E	5.00 BSC		
Exposed Pad Width	E2	3.20	3.25	3.30
Overall Length	D	5.00 BSC		
Exposed Pad Length	D2	3.20	3.25	3.30
Terminal Width	b	0.25	0.30	0.35
Terminal Length	L	0.35	0.40	0.45
Terminal-to-Exposed Pad	K	0.20	-	-

**Notes:**

1. Pin 1 visual index feature may vary, but must be located within the hatched area.
2. Package is saw singulated.
3. Dimensioning and tolerancing per ASME Y14.5M.
  - BSC: Basic Dimension. Theoretically exact value shown without tolerances.
  - REF: Reference Dimension, usually without tolerance, for information purposes only.

**Footprint Outlines and Dimensions**

**24-Lead Plastic Quad Flat, No Lead Package (LY) – 5x5x1.0 mm Body [QFN or VQFN]**

**Note:** For the most current package drawings, please see the Microchip Packaging Specification located at <http://www.microchip.com/packaging>

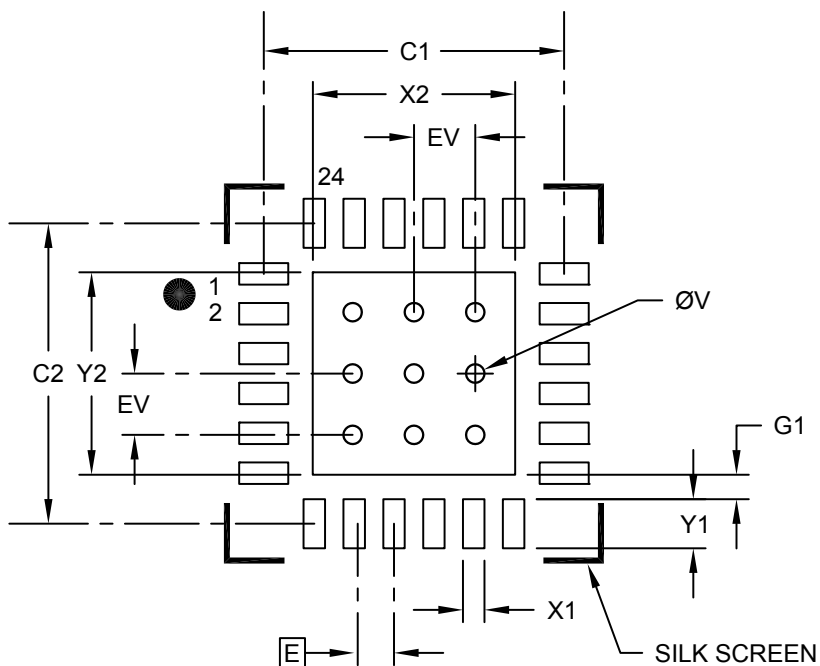

**RECOMMENDED LAND PATTERN**

Dimension Limits	Units	MILLIMETERS		
		MIN	NOM	MAX
Contact Pitch	E	0.65 BSC		
Center Pad Width	X2			3.30
Center Pad Length	Y2			3.30
Contact Pad Spacing	C1		4.90	
Contact Pad Spacing	C2		4.90	
Contact Pad Width (X24)	X1			0.35
Contact Pad Length (X24)	Y1			0.80
Contact Pad to Center Pad (X24)	G1	0.20		
Thermal Via Diameter	V		0.30	
Thermal Via Pitch	EV		1.00	

Notes:

1. Dimensioning and tolerancing per ASME Y14.5M

BSC: Basic Dimension. Theoretically exact value shown without tolerances.

Microchip Technology Drawing C04-2364A



---



---

## Package Outlines and Dimensions

---



---

### 28-Lead Plastic Quad Flat, No Lead Package (MK) – 4x4x0.9 mm Body [QFN]

**Note:** For the most current package drawings, please see the Microchip Packaging Specification located at <http://www.microchip.com/packaging>

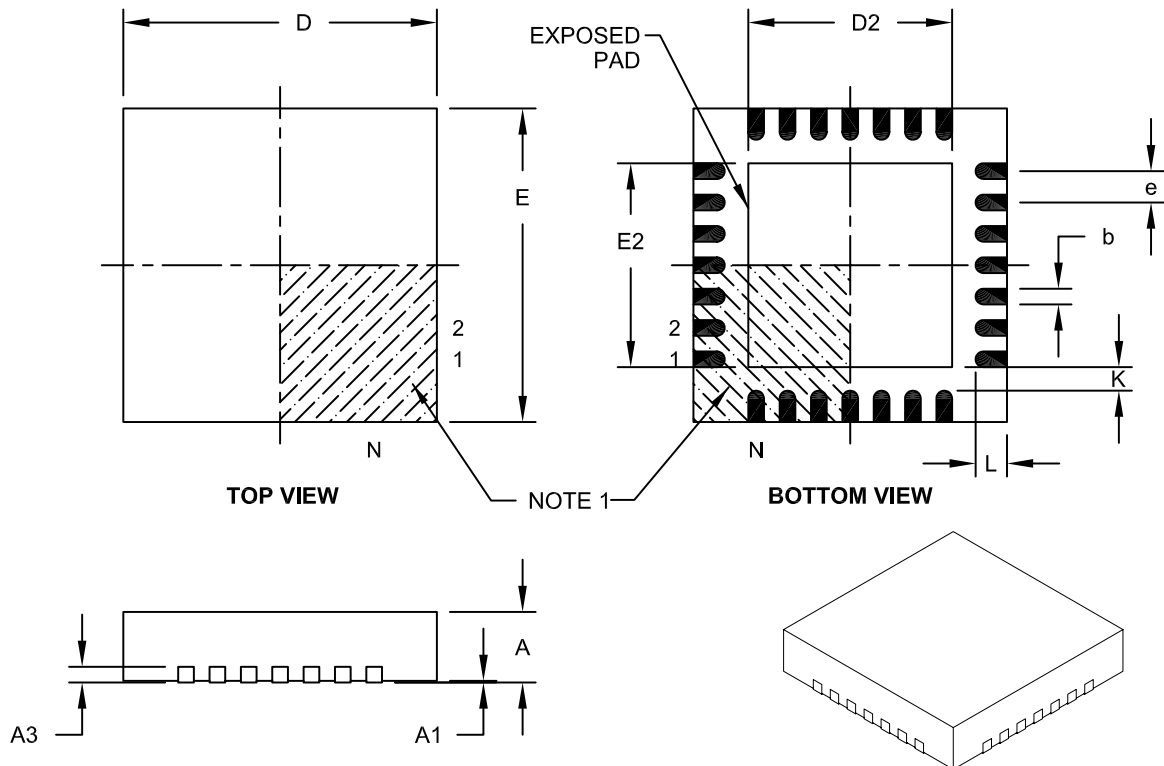

Dimension Limits	Units	MILLIMETERS		
		MIN	NOM	MAX
Number of Pins	N	28		
Pitch	e	0.40 BSC		
Overall Height	A	0.80	0.85	0.90
Standoff	A1	0.00	0.02	0.05
Contact Thickness	A3	0.20 REF		
Overall Width	E	4.00 BSC		
Exposed Pad Width	E2	2.50	2.60	2.70
Overall Length	D	4.00 BSC		
Exposed Pad Length	D2	2.50	2.60	2.70
Contact Width	b	0.17	0.20	0.25
Contact Length	L	0.30	0.40	0.50
Contact-to-Exposed Pad	K	0.20	-	-

**Notes:**

1. Pin 1 visual index feature may vary, but must be located within the hatched area.
2. Package is saw singulated.
3. Dimensioning and tolerancing per ASME Y14.5M.

BSC: Basic Dimension. Theoretically exact value shown without tolerances.

REF: Reference Dimension, usually without tolerance, for information purposes only.

Microchip Technology Drawing C04-144A

**Footprint Outlines and Dimensions**

**28-Lead Plastic Quad Flat, No Lead Package (MK) – 4x4x0.9 mm Body [QFN] Land Pattern**

**Note:** For the most current package drawings, please see the Microchip Packaging Specification located at <http://www.microchip.com/packaging>

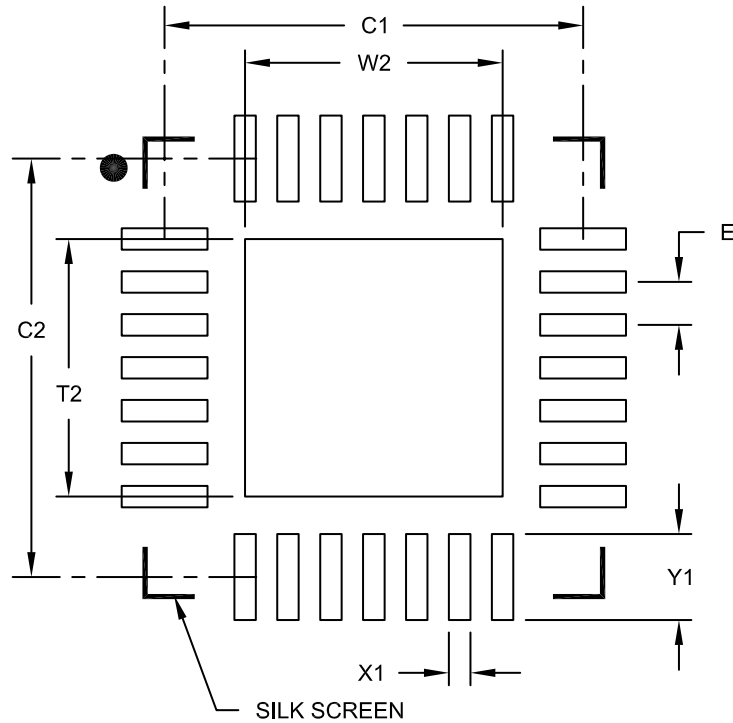

**RECOMMENDED LAND PATTERN**

Dimension Limits	Units	MILLIMETERS		
		MIN	NOM	MAX
Contact Pitch	E	0.40 BSC		
Optional Center Pad Width	W2			2.40
Optional Center Pad Length	T2			2.40
Contact Pad Spacing	C1		3.90	
Contact Pad Spacing	C2		3.90	
Contact Pad Width	X1			0.20
Contact Pad Length	Y1			0.80

**Notes:**

1. Dimensioning and tolerancing per ASME Y14.5M

BSC: Basic Dimension. Theoretically exact value shown without tolerances.

Microchip Technology Drawing No. C04-2144A

**Package Outlines and Dimensions**

**28-Lead Plastic Quad Flat, No Lead Package (MQ) – 5x5x0.9 mm Body [QFN or VQFN]**

**Note:** For the most current package drawings, please see the Microchip Packaging Specification located at <http://www.microchip.com/packaging>

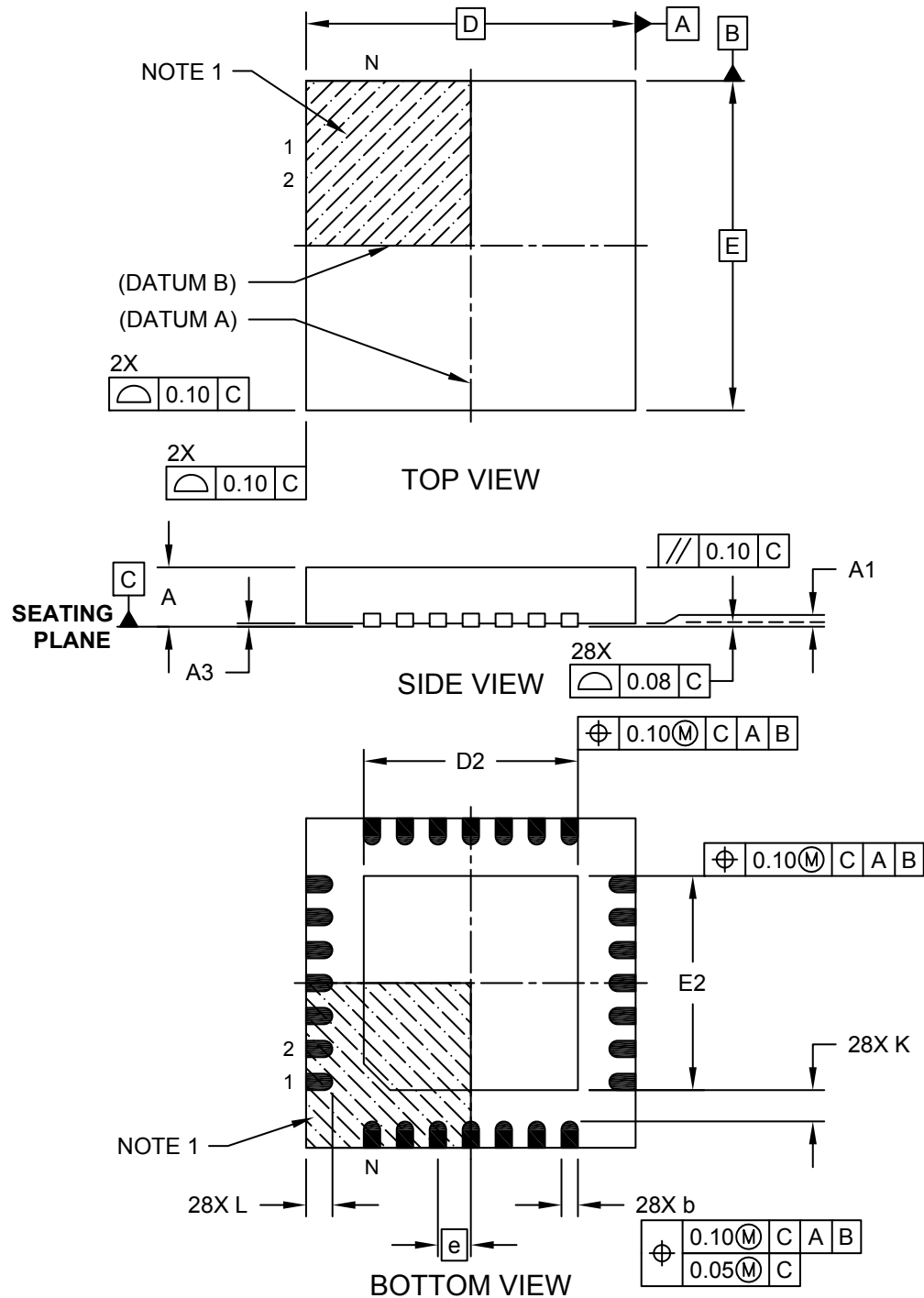

**Package Outlines and Dimensions**

**28-Lead Plastic Quad Flat, No Lead Package (MQ) – 5x5x0.9 mm Body [QFN or VQFN]**

**Note:** For the most current package drawings, please see the Microchip Packaging Specification located at <http://www.microchip.com/packaging>

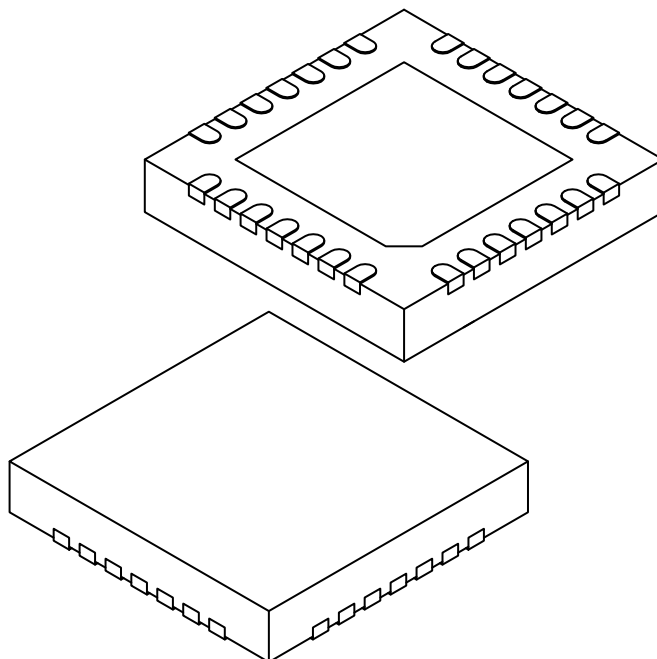

Dimension Limits	Units	MILLIMETERS		
		MIN	NOM	MAX
Number of Pins	N	28		
Pitch	e	0.50 BSC		
Overall Height	A	0.80	0.90	1.00
Standoff	A1	0.00	0.02	0.05
Contact Thickness	A3	0.20 REF		
Overall Width	E	5.00 BSC		
Exposed Pad Width	E2	3.15	3.25	3.35
Overall Length	D	5.00 BSC		
Exposed Pad Length	D2	3.15	3.25	3.35
Contact Width	b	0.18	0.25	0.30
Contact Length	L	0.35	0.40	0.45
Contact-to-Exposed Pad	K	0.20	-	-

**Notes:**

- Pin 1 visual index feature may vary, but must be located within the hatched area.
- Package is saw singulated.
- Dimensioning and tolerancing per ASME Y14.5M.  
 BSC: Basic Dimension. Theoretically exact value shown without tolerances.  
 REF: Reference Dimension, usually without tolerance, for information purposes only.

---



---

## Footprint Outlines and Dimensions

---



---

### 28-Lead Plastic Quad Flat, No Lead Package (MQ) – 5x5 mm Body [QFN] Land Pattern With 0.55 mm Contact Length

**Note:** For the most current package drawings, please see the Microchip Packaging Specification located at <http://www.microchip.com/packaging>

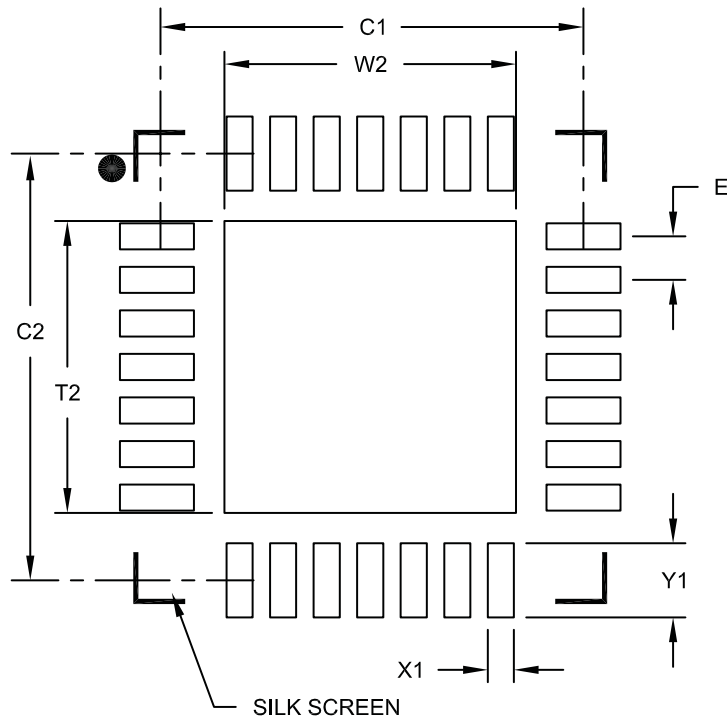

RECOMMENDED LAND PATTERN

		Units	MILLIMETERS		
		Dimension Limits	MIN	NOM	MAX
Contact Pitch	E	0.50 BSC			
Optional Center Pad Width	W2				3.35
Optional Center Pad Length	T2				3.35
Contact Pad Spacing	C1		4.90		
Contact Pad Spacing	C2		4.90		
Contact Pad Width (X28)	X1				0.30
Contact Pad Length (X28)	Y1				0.85

**Notes:**

1. Dimensioning and tolerancing per ASME Y14.5M

BSC: Basic Dimension. Theoretically exact value shown without tolerances.

Microchip Technology Drawing C04-2140A

**Package Outlines and Dimensions**

**28-Lead Plastic Quad Flat, No Lead Package (MQY) – 5x5x0.9 mm Body [QFN or VQFN]**

**Note:** For the most current package drawings, please see the Microchip Packaging Specification located at <http://www.microchip.com/packaging>

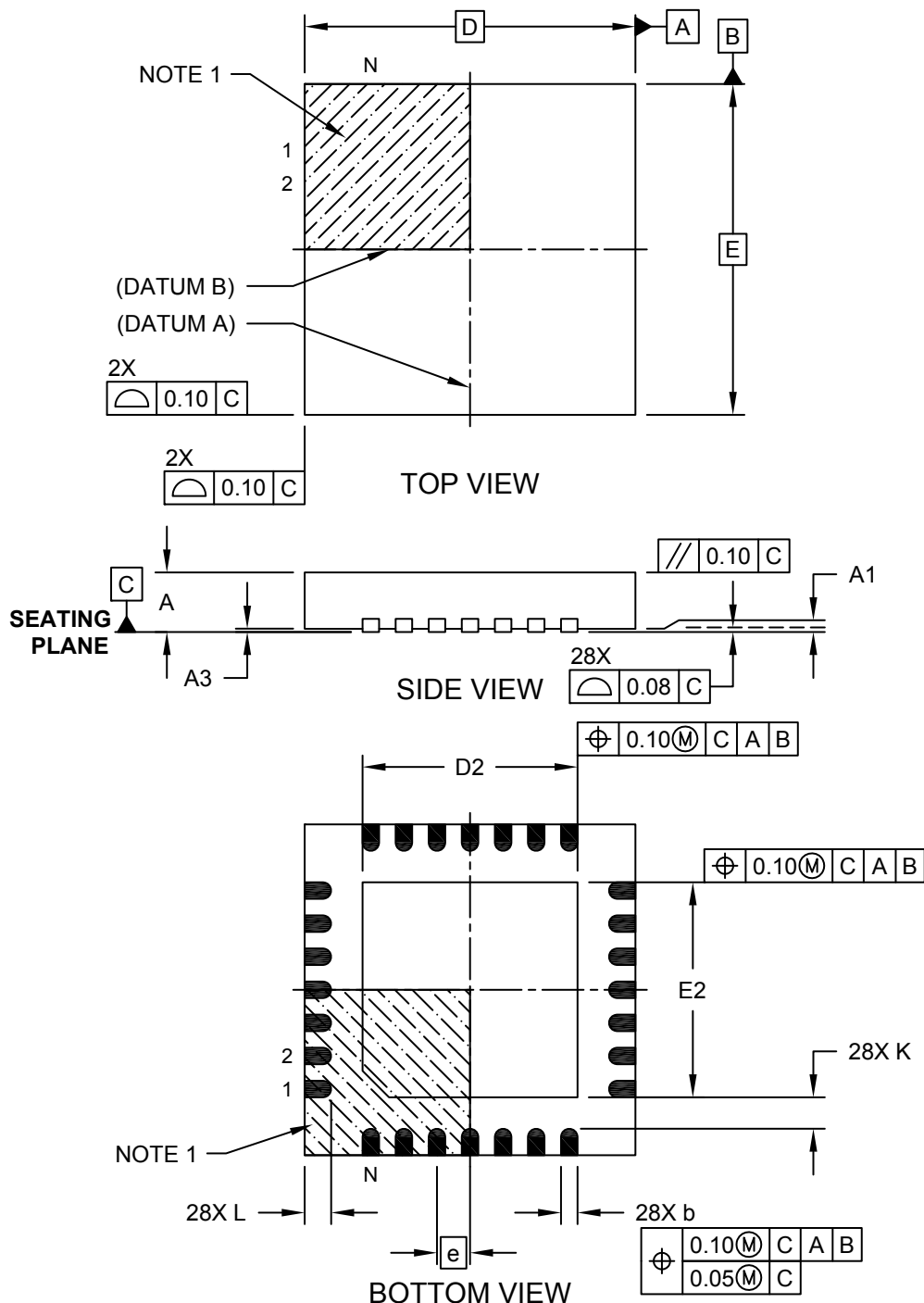

---



---

## Package Outlines and Dimensions

---



---

### 28-Lead Plastic Quad Flat, No Lead Package (MQY) – 5x5x0.9 mm Body [QFN or VQFN]

**Note:** For the most current package drawings, please see the Microchip Packaging Specification located at <http://www.microchip.com/packaging>

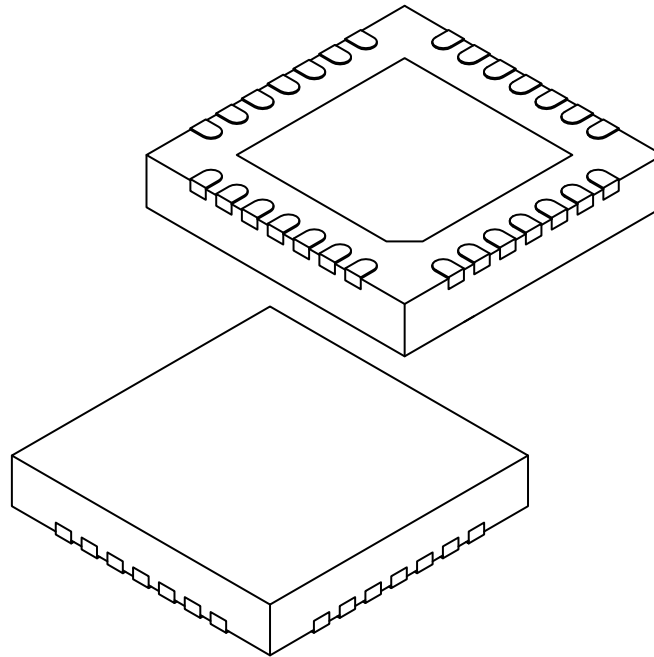

Dimension Limits	Units	MILLIMETERS		
		MIN	NOM	MAX
Number of Pins	N	28		
Pitch	e	0.50 BSC		
Overall Height	A	0.80	0.90	1.00
Standoff	A1	0.00	0.02	0.05
Contact Thickness	A3	0.20 REF		
Overall Width	E	5.00 BSC		
Exposed Pad Width	E2	3.15	3.25	3.35
Overall Length	D	5.00 BSC		
Exposed Pad Length	D2	3.15	3.25	3.35
Contact Width	b	0.18	0.25	0.30
Contact Length	L	0.35	0.40	0.45
Contact-to-Exposed Pad	K	0.20	-	-

**Notes:**

1. Pin 1 visual index feature may vary, but must be located within the hatched area.
2. Package is saw singulated.
3. Dimensioning and tolerancing per ASME Y14.5M.
  - BSC: Basic Dimension. Theoretically exact value shown without tolerances.
  - REF: Reference Dimension, usually without tolerance, for information purposes only.

**Footprint Outlines and Dimensions**

**28-Lead Plastic Quad Flat, No Lead Package (MQY) – 5x5x0.9 mm Body  
[QFN or VQFN]**

**Note:** For the most current package drawings, please see the Microchip Packaging Specification located at <http://www.microchip.com/packaging>

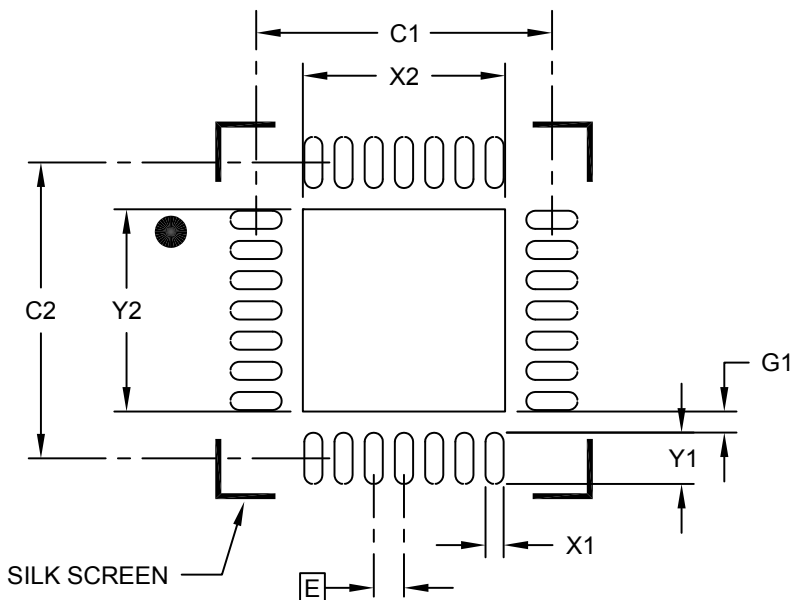

**RECOMMENDED LAND PATTERN**

Units		MILLIMETERS		
Dimension Limits		MIN	NOM	MAX
Contact Pitch	E	0.50 BSC		
Optional Center Pad Width	W2			3.35
Optional Center Pad Length	T2			3.35
Contact Pad Spacing	C1		4.90	
Contact Pad Spacing	C2		4.90	
Contact Pad Width (X28)	X1			0.30
Contact Pad Length (X28)	Y1			0.85
Contact Pad Length (X28)	G1	0.35		

**Notes:**

1. Dimensioning and tolerancing per ASME Y14.5M

BSC: Basic Dimension. Theoretically exact value shown without tolerances.

Microchip Technology Drawing No. C04-2140A



**Package Outlines and Dimensions**

**28-Lead Plastic Quad Flat, No Lead Package (ML) - 6x6 mm Body [QFN]  
With 0.55 mm Terminal Length**

**Note:** For the most current package drawings, please see the Microchip Packaging Specification located at <http://www.microchip.com/packaging>

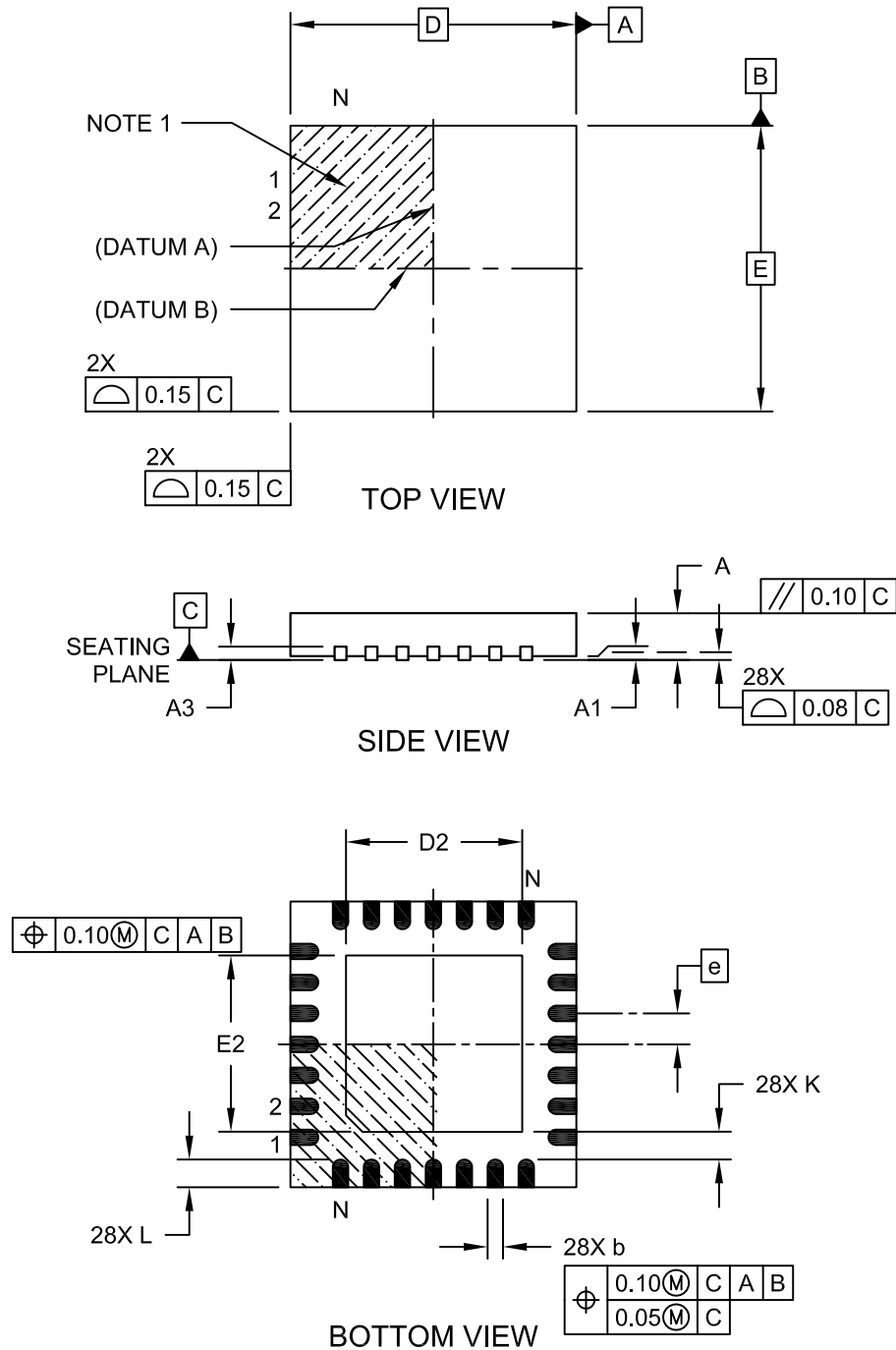

**Package Outlines and Dimensions**

**28-Lead Plastic Quad Flat, No Lead Package (ML) - 6x6 mm Body [QFN]  
With 0.55 mm Terminal Length**

**Note:** For the most current package drawings, please see the Microchip Packaging Specification located at <http://www.microchip.com/packaging>

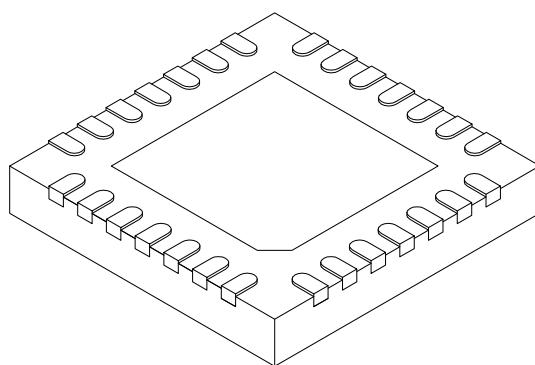

Dimension	Units Limits	MILLIMETERS		
		MIN	NOM	MAX
Number of Pins	N	28		
Pitch	e	0.65 BSC		
Overall Height	A	0.80	0.90	1.00
Standoff	A1	0.00	0.02	0.05
Terminal Thickness	A3	0.20 REF		
Overall Width	E	6.00 BSC		
Exposed Pad Width	E2	3.65	3.70	4.20
Overall Length	D	6.00 BSC		
Exposed Pad Length	D2	3.65	3.70	4.20
Terminal Width	b	0.23	0.30	0.35
Terminal Length	L	0.50	0.55	0.70
Terminal-to-Exposed Pad	K	0.20	-	-

**Notes:**

- Pin 1 visual index feature may vary, but must be located within the hatched area.
- Package is saw singulated
- Dimensioning and tolerancing per ASME Y14.5M.
  - BSC: Basic Dimension. Theoretically exact value shown without tolerances.
  - REF: Reference Dimension, usually without tolerance, for information purposes only.

---



---

## Footprint Outlines and Dimensions

---



---

### 28-Lead Plastic Quad Flat, No Lead Package (ML) – 6x6 mm Body [QFN] with 0.55 mm Contact Length

**Note:** For the most current package drawings, please see the Microchip Packaging Specification located at <http://www.microchip.com/packaging>

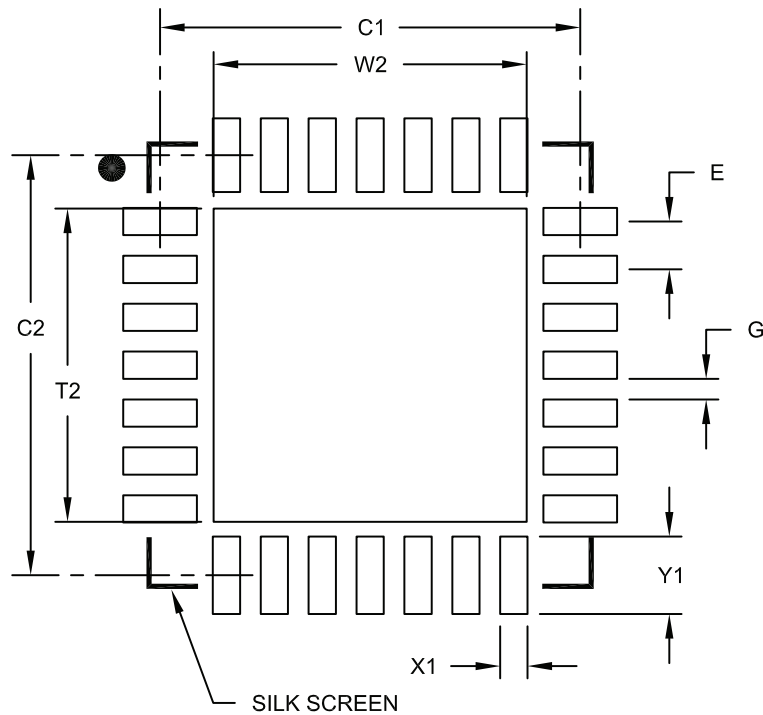

**RECOMMENDED LAND PATTERN**

Dimension Limits	Units	MILLIMETERS		
		MIN	NOM	MAX
Contact Pitch	E	0.65 BSC		
Optional Center Pad Width	W2			4.25
Optional Center Pad Length	T2			4.25
Contact Pad Spacing	C1		5.70	
Contact Pad Spacing	C2		5.70	
Contact Pad Width (X28)	X1			0.37
Contact Pad Length (X28)	Y1			1.00
Distance Between Pads	G	0.20		

**Notes:**

1. Dimensioning and tolerancing per ASME Y14.5M

BSC: Basic Dimension. Theoretically exact value shown without tolerances.

Microchip Technology Drawing No. C04-2105A

**Package Outlines and Dimensions**

**32-Lead Plastic Quad Flat, No Lead Package (3E) - 5x5 mm Body [QFN], 0.40 mm Terminals With 3.3x3.3 Exposed Pad; Punch Singulated, Dimpled Terminals**

**Note:** For the most current package drawings, please see the Microchip Packaging Specification located at <http://www.microchip.com/packaging>

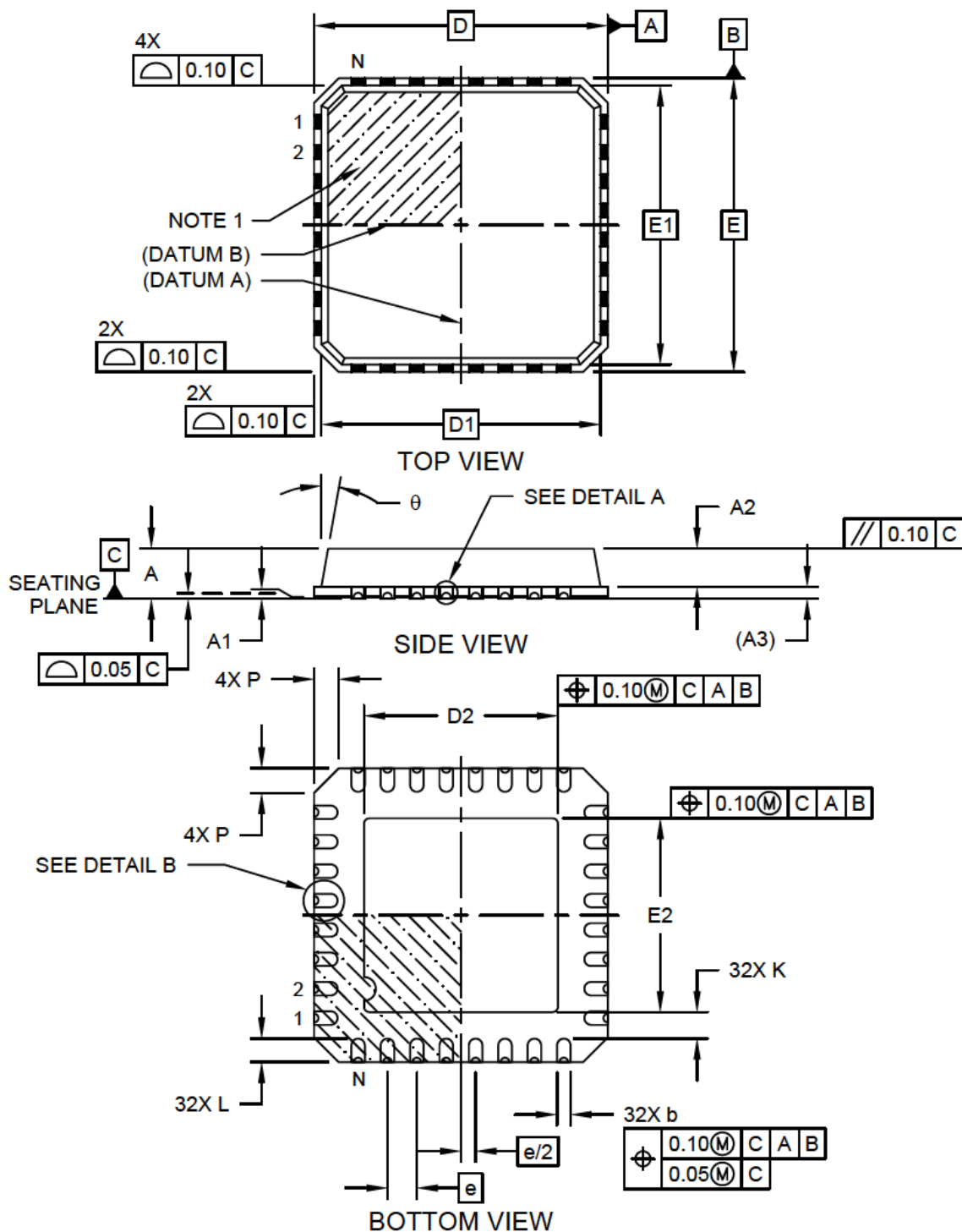

---



---

## Package Outlines and Dimensions

---



---

### 32-Lead Plastic Quad Flat, No Lead Package (3E) - 5x5 mm Body [QFN], 0.40 mm Terminals With 3.3x3.3 Exposed Pad; Punch Singulated, Dimpled Terminals

**Note:** For the most current package drawings, please see the Microchip Packaging Specification located at <http://www.microchip.com/packaging>

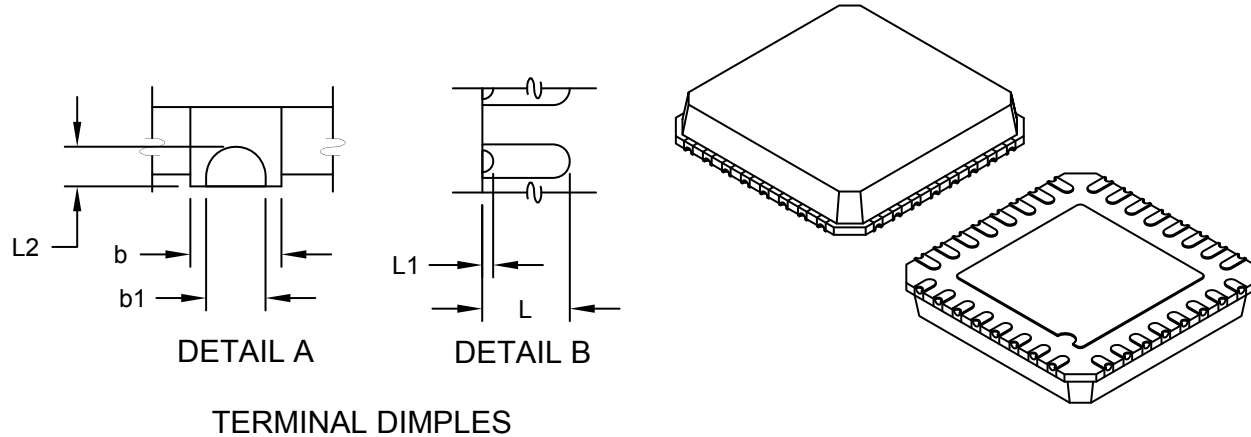

TERMINAL DIMPLES

Dimension Limits	Units	MILLIMETERS		
		MIN	NOM	MAX
Number of Terminals	N	32		
Pitch	e	0.50 BSC		
Overall Height	A	0.80	0.85	0.90
Standoff	A1	0.00	0.01	0.05
Mold Cap Height	A2	0.60	0.65	0.70
Terminal Thickness	(A3)	0.20 REF		
Overall Width	E	5.00 BSC		
Molded Top Width	E1	4.75 BSC		
Exposed Pad Width	E2	3.20	3.30	3.40
Overall Length	D	5.00 BSC		
Molded Top Length	D1	4.75 BSC		
Exposed Pad Length	D2	3.20	3.30	3.40
Corner Chamfer	P	0.24	0.42	0.60
Terminal Width	b	0.20	0.25	0.30
Terminal Dimple Width	b1	0.10	0.15	0.20
Terminal Length	L	0.30	0.40	0.50
Terminal Dimple Length (side)	L1	0.05	0.15	0.25
Terminal Dimple Length (bottom)	L2	0.05	0.10	0.15
Terminal-to-Exposed-Pad	K	0.20	-	-
Mold Draft Angle	$\theta$	0°	-	12°

**Notes:**

1. Pin 1 visual index feature may vary, but must be located within the hatched area.
2. Package is punch singulated
3. Dimensioning and tolerancing per ASME Y14.5M

BSC: Basic Dimension. Theoretically exact value shown without tolerances.

REF: Reference Dimension, usually without tolerance, for information purposes only.

**Footprint Outlines and Dimensions**

**32-Lead Plastic Quad Flat, No Lead Package (3E) - 5x5 mm Body [QFN], 0.40 mm Terminals With 3.3x3.3 Exposed Pad; Punch Singulated, Dimpled Terminals**

**Note:** For the most current package drawings, please see the Microchip Packaging Specification located at <http://www.microchip.com/packaging>

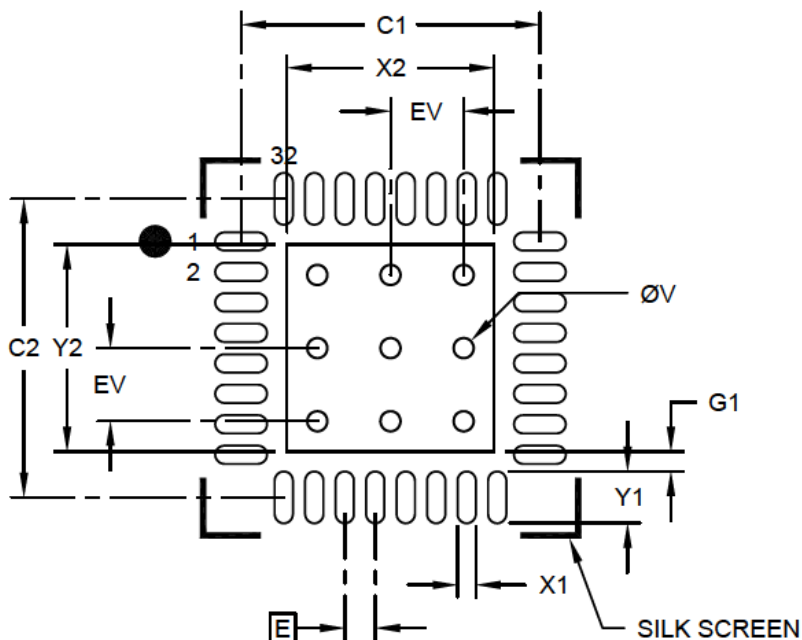

**RECOMMENDED LAND PATTERN**

Dimension Limits	Units	MILLIMETERS		
		MIN	NOM	MAX
Contact Pitch	E	0.50 BSC		
Optional Center Pad Width	X2			3.40
Optional Center Pad Length	Y2			3.40
Contact Pad Spacing	C1		4.90	
Contact Pad Spacing	C2		4.90	
Contact Pad Width (X32)	X1			0.30
Contact Pad Length (X32)	Y1			0.85
Contact Pad to Center Pad (X32)	G1	0.20		
Thermal Via Diameter	V		0.33	
Thermal Via Pitch	EV		1.20	

**Notes:**

1. Dimensioning and tolerancing per ASME Y14.5M  
BSC: Basic Dimension. Theoretically exact value shown without tolerances.
2. For best soldering results, thermal vias, if used, should be filled or tented to avoid solder loss during reflow process

**Package Outlines and Dimensions**

**36-Lead Plastic Quad Flat, No Lead Package (4E) - 6x6 mm Body [QFN]  
With 3.7x3.7 mm Exposed Pad; Punch Singulated, 0.40 mm Dimpled Terminals**

**Note:** For the most current package drawings, please see the Microchip Packaging Specification located at <http://www.microchip.com/packaging>

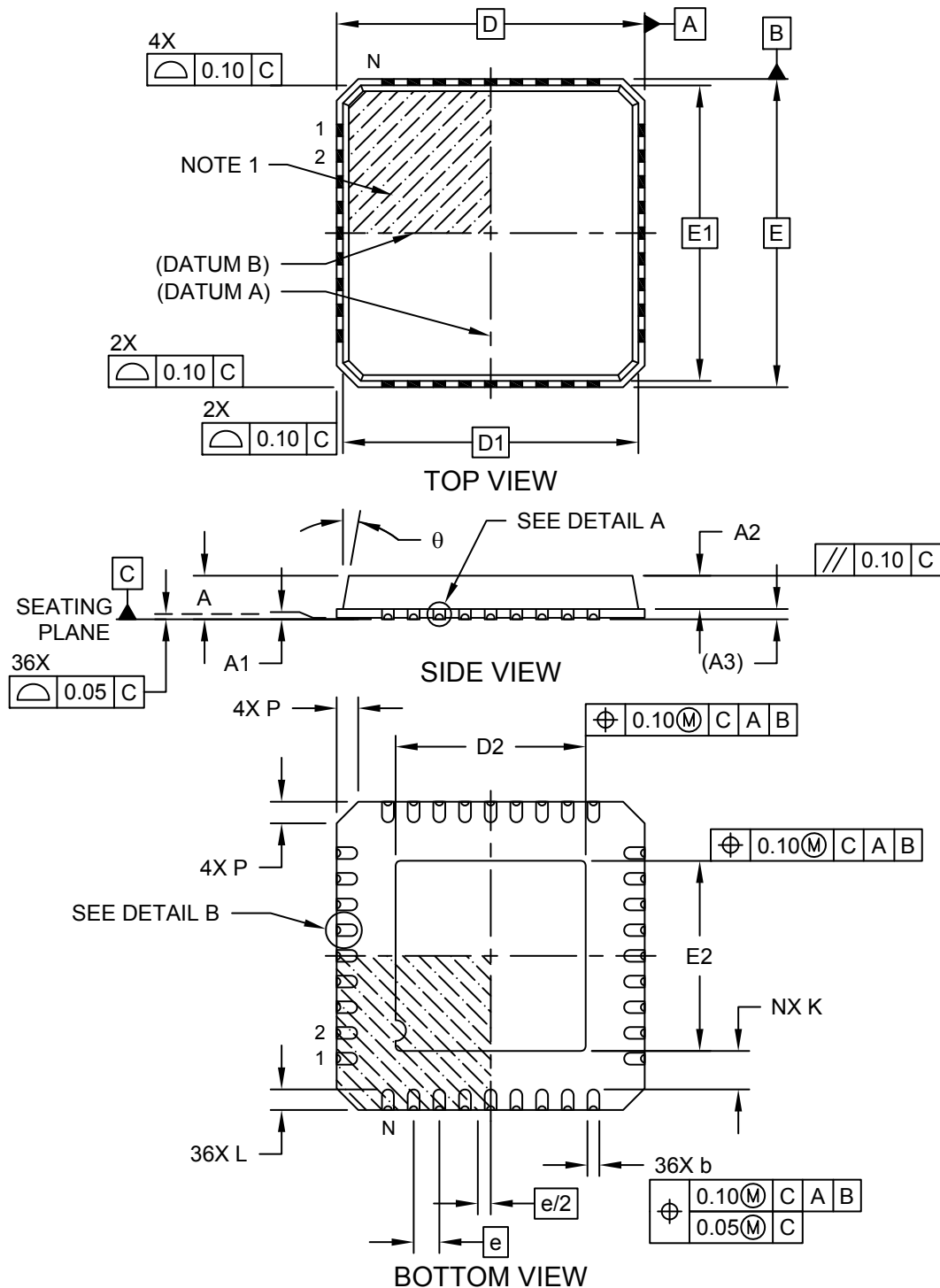

Microchip Technology Drawing C04-241A Sheet 1 of 2

**Package Outlines and Dimensions**

**36-Lead Plastic Quad Flat, No Lead Package (4E) - 6x6 mm Body [QFN]  
With 3.7x3.7 mm Exposed Pad; Punch Singulated, 0.40 mm Dimpled Terminals**

**Note:** For the most current package drawings, please see the Microchip Packaging Specification located at <http://www.microchip.com/packaging>

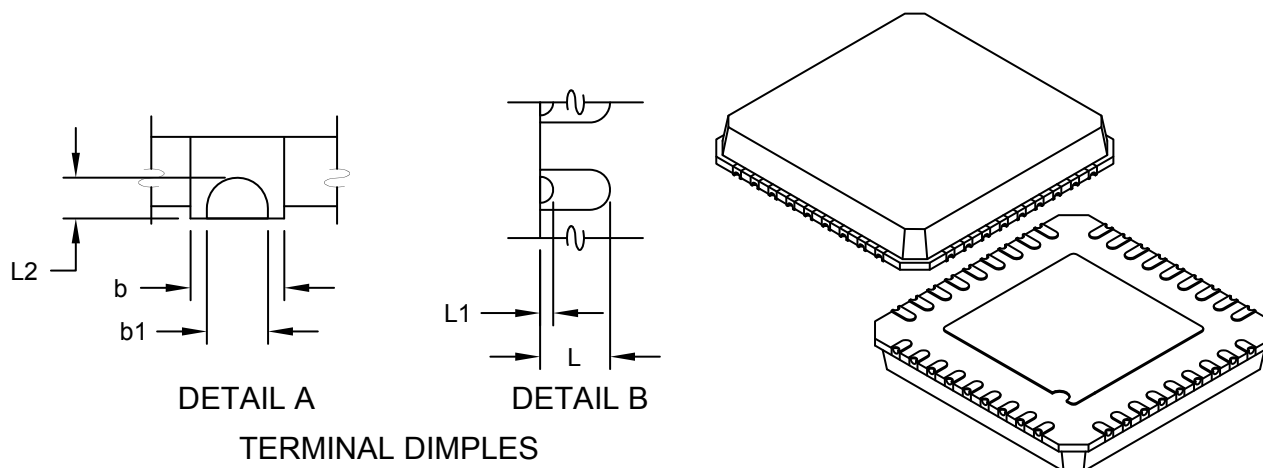

**TERMINAL DIMPLES**

Dimension Limits	Units	MILLIMETERS		
		MIN	NOM	MAX
Number of Terminals	N	36		
Pitch	e	0.50 BSC		
Overall Height	A	0.80	0.85	0.90
Standoff	A1	0.00	0.01	0.05
Mold Cap Height	A2	0.60	0.65	0.70
Terminal Thickness	(A3)	0.20 REF		
Overall Width	E	6.00 BSC		
Molded Top Width	E1	5.75 BSC		
Exposed Pad Width	E2	3.60	3.70	3.80
Overall Length	D	6.00 BSC		
Molded Top Length	D1	5.75 BSC		
Exposed Pad Length	D2	3.60	3.70	3.80
Corner Chamfer	P	0.24	0.42	0.60
Terminal Width	b	0.20	0.25	0.30
Terminal Dimple Width	b1	0.10	0.15	0.20
Terminal Length	L	0.30	0.40	0.50
Terminal Dimple Length (side)	L1	0.05	0.15	0.25
Terminal Dimple Length (bottom)	L2	0.05	0.10	0.15
Terminal-to-Exposed-Pad	K	0.20	-	-
Mold Draft Angle	$\theta$	0°	-	12°

**Notes:**

1. Pin 1 visual index feature may vary, but must be located within the hatched area.
2. Package is punch singulated
3. Dimensioning and tolerancing per ASME Y14.5M

BSC: Basic Dimension. Theoretically exact value shown without tolerances.

REF: Reference Dimension, usually without tolerance, for information purposes only.



---



---

## Footprint Outlines and Dimensions

---



---

### 36-Lead Plastic Quad Flat, No Lead Package (4E) - 6x6 mm Body [QFN] With 3.7x3.7 mm Exposed Pad; Punch Singulated, 0.40 mm Dimpled Terminals

**Note:** For the most current package drawings, please see the Microchip Packaging Specification located at <http://www.microchip.com/packaging>

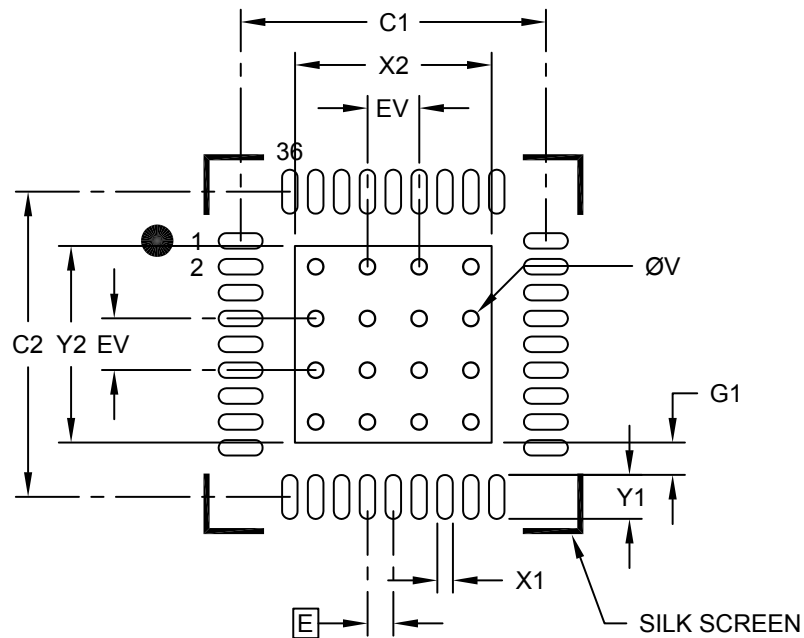

### RECOMMENDED LAND PATTERN

	Units	MILLIMETERS		
		MIN	NOM	MAX
	Dimension Limits			
Contact Pitch	E	0.50 BSC		
Optional Center Pad Width	X2			3.80
Optional Center Pad Length	Y2			3.80
Contact Pad Spacing	C1		5.90	
Contact Pad Spacing	C2		5.90	
Contact Pad Width (X36)	X1			0.30
Contact Pad Length (X36)	Y1			0.85
Contact Pad to Center Pad (X32)	G1	0.20		
Thermal Via Diameter	V		0.30	
Thermal Via Pitch	EV		1.00	

**Notes:**

1. Dimensioning and tolerancing per ASME Y14.5M

BSC: Basic Dimension. Theoretically exact value shown without tolerances.

Microchip Technology Drawing C04-2241A

**Package Outlines and Dimensions**

**40-Lead Plastic Quad Flat, No Lead Package (RR) - 6x6 mm Body [QFN]  
With 4.1x4.1 mm Exposed Pad; Punch Singulated**

**Note:** For the most current package drawings, please see the Microchip Packaging Specification located at <http://www.microchip.com/packaging>

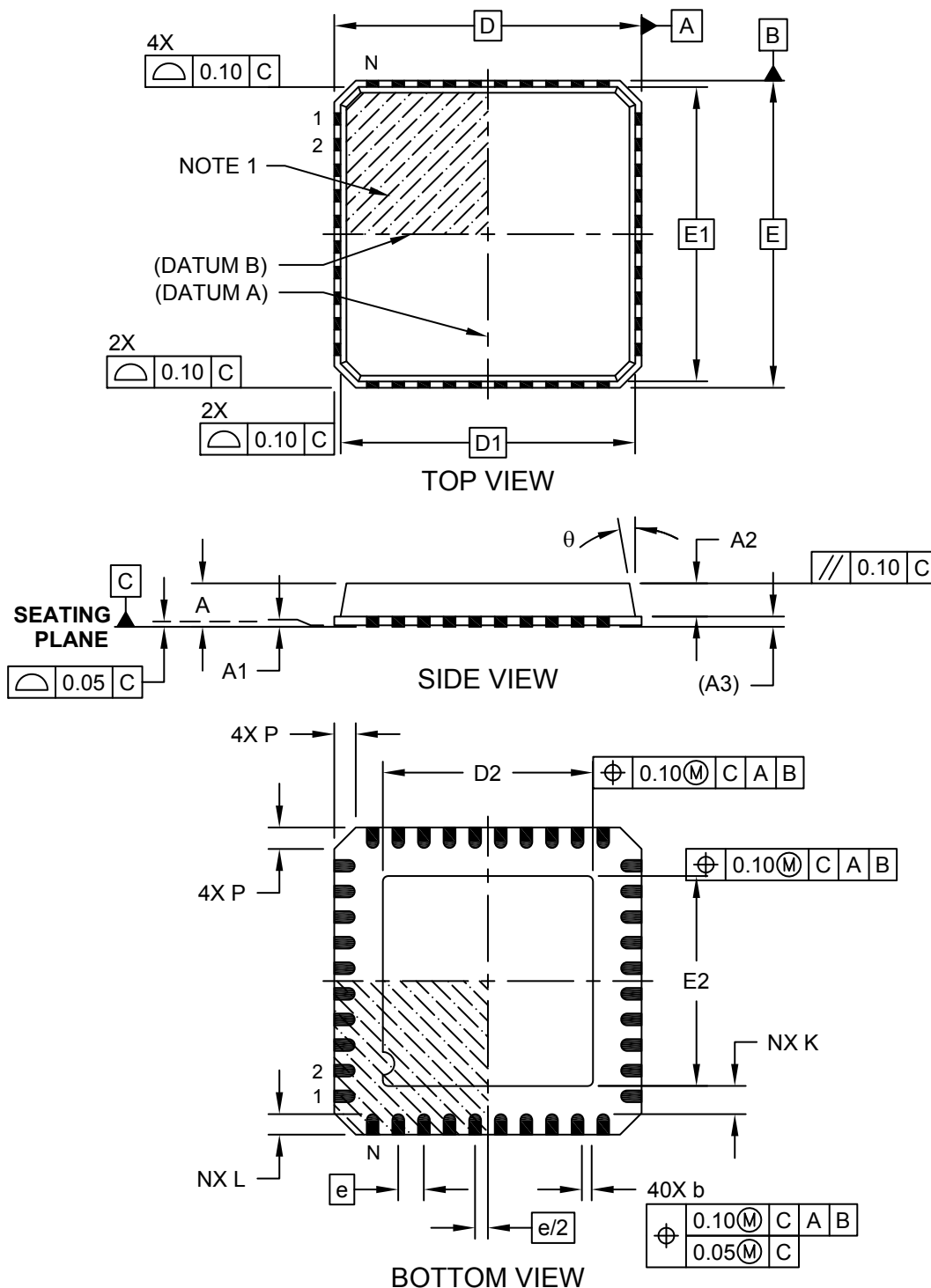

Microchip Technology Drawing C04-229A Sheet 1 of 2

---



---

## Package Outlines and Dimensions

---



---

### 40-Lead Plastic Quad Flat, No Lead Package (RR) - 6x6 mm Body [QFN] With 4.1x4.1 mm Exposed Pad; Punch Singulated

**Note:** For the most current package drawings, please see the Microchip Packaging Specification located at <http://www.microchip.com/packaging>

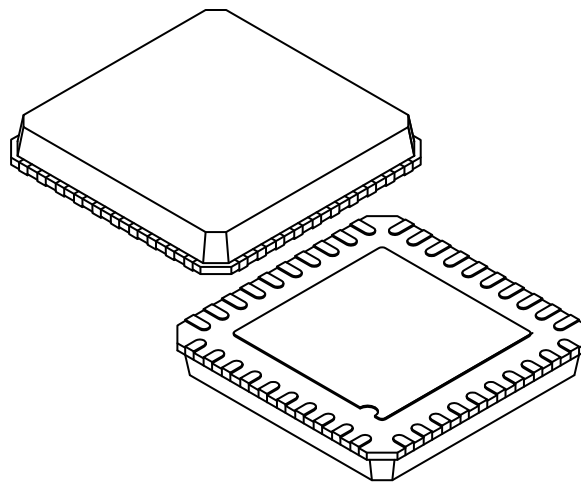

Dimension Limits	Units	MILLIMETERS		
		MIN	NOM	MAX
Number of Pins	N	40		
Pitch	e	0.50 BSC		
Overall Height	A	0.80	0.85	0.90
Standoff	A1	0.00	0.01	0.05
Mold Cap Height	A2	0.60	0.65	0.70
Terminal Thickness	(A3)	0.20 REF		
Overall Width	E	6.00 BSC		
Molded Top Width	E1	5.75 BSC		
Exposed Pad Width	E2	4.00	4.10	4.20
Overall Length	D	6.00 BSC		
Molded Top Length	D1	5.75 BSC		
Exposed Pad Length	D2	4.00	4.10	4.20
Corner Chamfer	P	0.24	0.42	0.60
Terminal Width	b	0.18	0.23	0.30
Terminal Length	L	0.30	0.40	0.50
Terminal-to-Exposed-Pad	K	0.20	-	-
Mold Draft Angle	$\theta$	0°	-	12°

**Notes:**

1. Pin 1 visual index feature may vary, but must be located within the hatched area.
2. Package is punch singulated
3. Dimensioning and tolerancing per ASME Y14.5M

BSC: Basic Dimension. Theoretically exact value shown without tolerances.

REF: Reference Dimension, usually without tolerance, for information purposes only.

**Footprint Outlines and Dimensions**

**40-Lead Plastic Quad Flat, No Lead Package (RR) - 6x6 mm Body [QFN]  
With 4.1x4.1mm Exposed Pad; Punch Singulated**

**Note:** For the most current package drawings, please see the Microchip Packaging Specification located at <http://www.microchip.com/packaging>

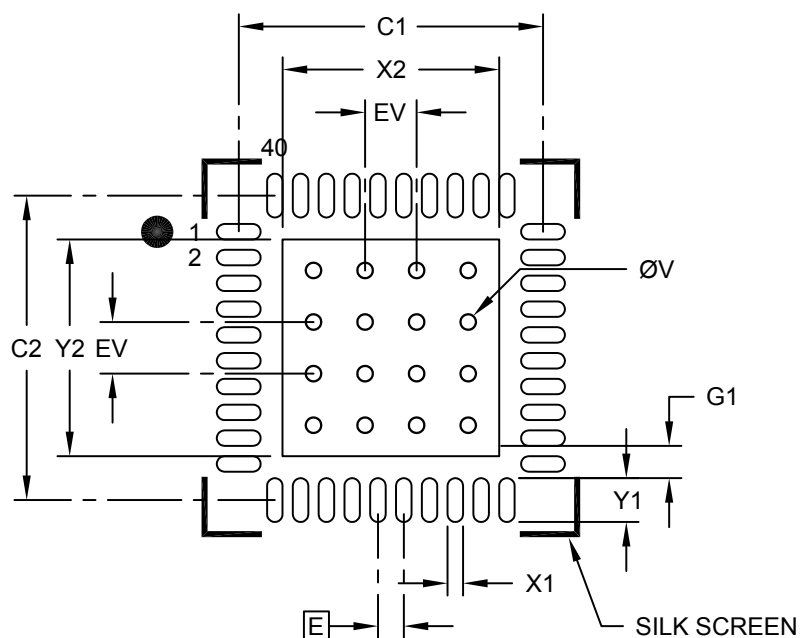

**RECOMMENDED LAND PATTERN**

Dimension Limits	Units	MILLIMETERS		
		MIN	NOM	MAX
Contact Pitch	E	0.50 BSC		
Optional Center Pad Width	X2			4.20
Optional Center Pad Length	Y2			4.20
Contact Pad Spacing	C1		5.90	
Contact Pad Spacing	C2		5.90	
Contact Pad Width (X40)	X1			0.30
Contact Pad Length (X40)	Y1			0.85
Contact Pad to Center Pad (X40)	G1	0.20		
Thermal Via Diameter	V		0.30	
Thermal Via Pitch	EV		1.00	

**Notes:**

- Dimensioning and tolerancing per ASME Y14.5M  
BSC: Basic Dimension. Theoretically exact value shown without tolerances.
- For best soldering results, thermal vias, if used, should be "filled" or "tented" to avoid solder loss during reflow process

**Package Outlines and Dimensions**

**40-Lead Plastic Quad Flat, No Lead Package (ML) - 6x6x0.9mm Body [QFN]  
With 0.40mm Contact Length**

**Note:** For the most current package drawings, please see the Microchip Packaging Specification located at <http://www.microchip.com/packaging>

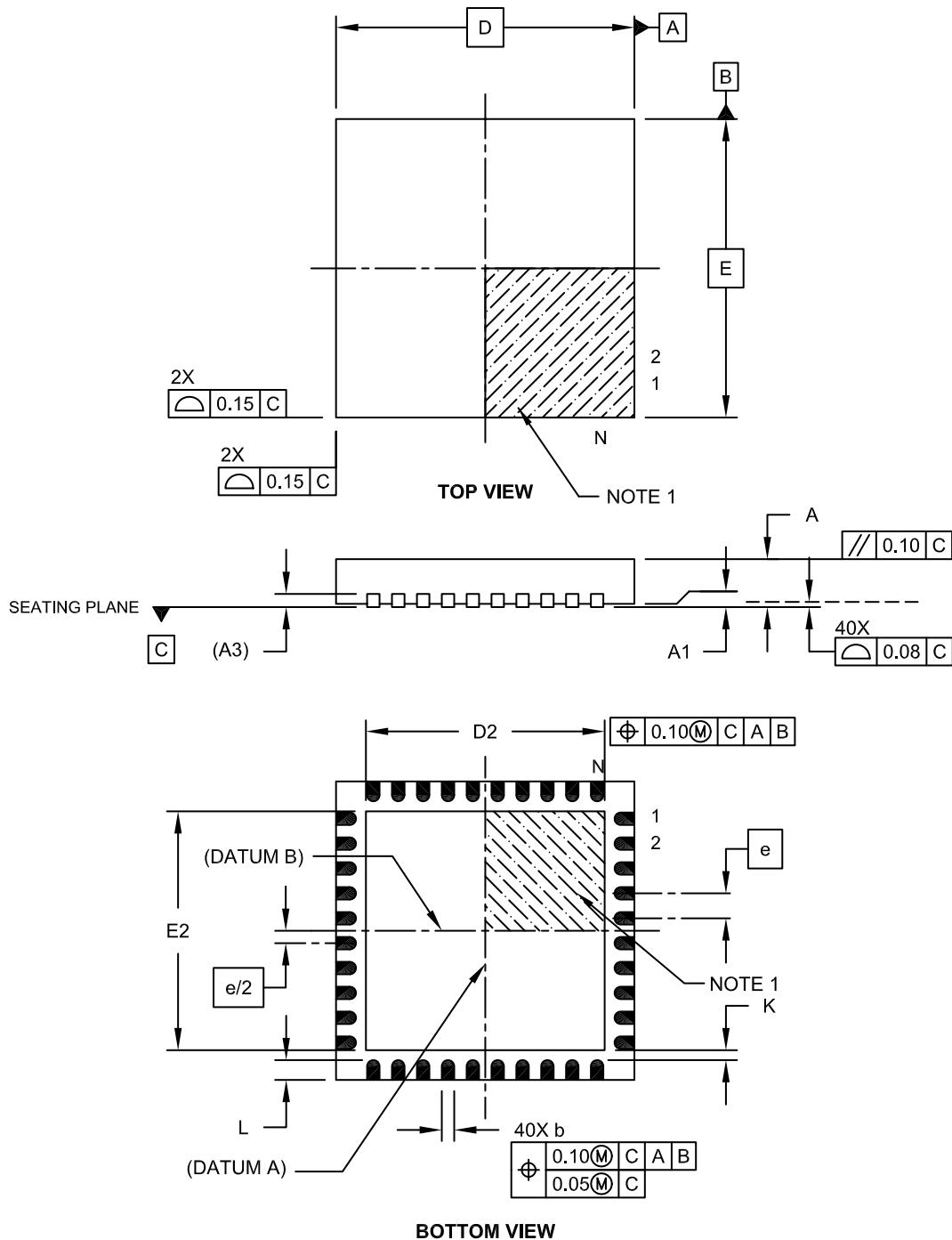

**Package Outlines and Dimensions**

**40-Lead Plastic Quad Flat, No Lead Package (ML) - 6x6x0.9mm Body [QFN]  
With 0.40mm Contact Length**

**Note:** For the most current package drawings, please see the Microchip Packaging Specification located at <http://www.microchip.com/packaging>

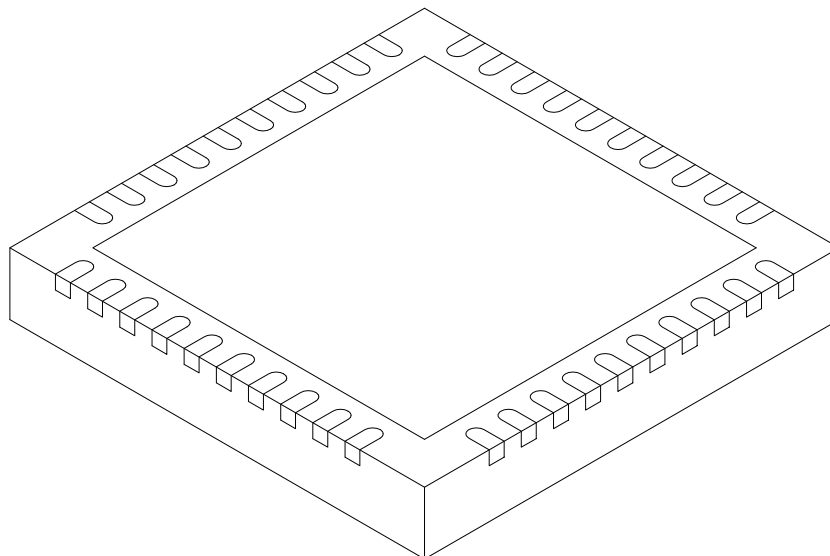

Dimension Limits	Units	MILLIMETERS		
		MIN	NOM	MAX
Number of Pins	N	40		
Pitch	e	0.50 BSC		
Overall Height	A	0.80	0.90	1.00
Standoff	A1	0.00	0.02	0.05
Contact Thickness	A3	0.20 REF		
Overall Width	E	6.00 BSC		
Exposed Pad Width	E2	4.50	4.65	4.80
Overall Length	D	6.00 BSC		
Exposed Pad Length	D2	4.50	4.65	4.80
Contact Width	b	0.18	0.25	0.30
Contact Length	L	0.30	0.40	0.50
Contact-to-Exposed Pad	K	0.20	-	-

**Notes:**

- Pin 1 visual index feature may vary, but must be located within the hatched area.
- Package is saw singulated.
- Dimensioning and tolerancing per ASME Y14.5M.

BSC: Basic Dimension. Theoretically exact value shown without tolerances.

REF: Reference Dimension, usually without tolerance, for information purposes only.

---



---

## Footprint Outlines and Dimensions

---



---

40-Lead Plastic Quad Flat, No Lead Package (ML) - 6x6x0.9mm Body [QFN]  
 With 0.40mm Contact Length

**Note:** For the most current package drawings, please see the Microchip Packaging Specification located at <http://www.microchip.com/packaging>

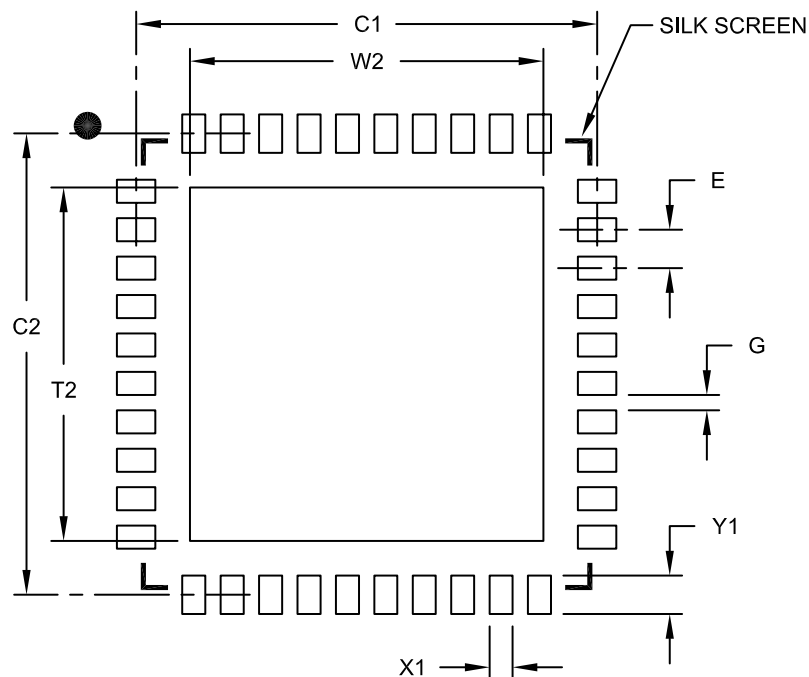

RECOMMENDED LAND PATTERN

Dimension Limits	Units	MILLIMETERS		
		MIN	NOM	MAX
Contact Pitch	E	0.50 BSC		
Optional Center Pad Width	W2			4.60
Optional Center Pad Length	T2			4.60
Contact Pad Spacing	C1		6.00	
Contact Pad Spacing	C2		6.00	
Contact Pad Width (X40)	X1			0.30
Contact Pad Length (X40)	Y1			0.50
Distance Between Pads	G	0.20		

**Notes:**

1. Dimensioning and tolerancing per ASME Y14.5M

BSC: Basic Dimension. Theoretically exact value shown without tolerances.

Microchip Technology Drawing No. C04-2118A

**Package Outlines and Dimensions**

**40-Lead Plastic Quad Flat, No Lead Package (MP) - 5x5 mm Body [QFN]  
With 3.5x3.5 mm Exposed Pad**

**Note:** For the most current package drawings, please see the Microchip Packaging Specification located at <http://www.microchip.com/packaging>

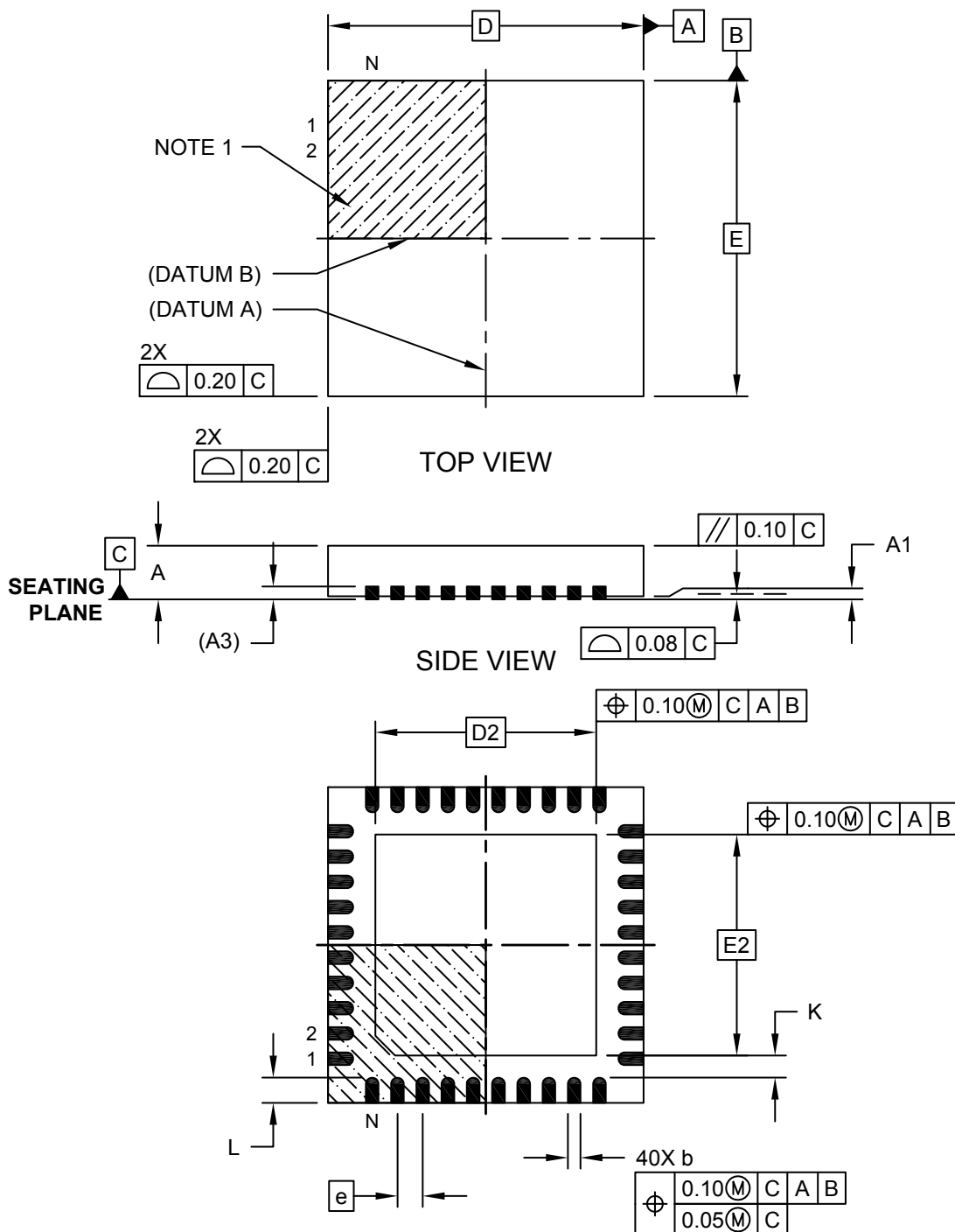



---



---

## Package Outlines and Dimensions

---



---

### 40-Lead Plastic Quad Flat, No Lead Package (MP) - 5x5 mm Body [QFN] With 3.5x3.5 mm Exposed Pad

**Note:** For the most current package drawings, please see the Microchip Packaging Specification located at <http://www.microchip.com/packaging>

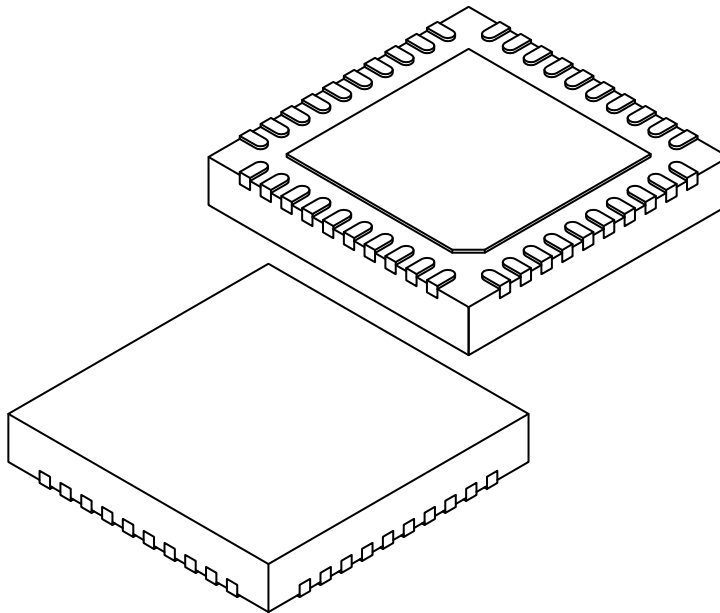

		MILLIMETERS		
Units				
Dimension Limits		MIN	NOM	MAX
Number of Terminals	N	40		
Pitch	e	0.40 BSC		
Overall Height	A	0.80	0.85	0.90
Standoff	A1	0.00	0.02	0.05
Terminal Thickness	A3	0.20 REF		
Overall Width	E	5.00 BSC		
Exposed Pad Width	E2	3.50 BSC		
Overall Length	D	5.00 BSC		
Exposed Pad Length	D2	3.50 BSC		
Terminal Width	b	0.17	0.20	0.25
Terminal Length	L	0.30	0.40	0.50
Terminal-to-Exposed-Pad	K	0.20	-	-

**Notes:**

1. Pin 1 visual index feature may vary, but must be located within the hatched area.
2. Package is saw singulated
3. Dimensioning and tolerancing per ASME Y14.5M
  - BSC: Basic Dimension. Theoretically exact value shown without tolerances.
  - REF: Reference Dimension, usually without tolerance, for information purposes only.

**Footprint Outlines and Dimensions**

**40-Lead Plastic Quad Flat, No Lead Package (MP) - 5x5 mm Body [QFN]  
With 3.5x3.5 mm Exposed Pad**

**Note:** For the most current package drawings, please see the Microchip Packaging Specification located at <http://www.microchip.com/packaging>

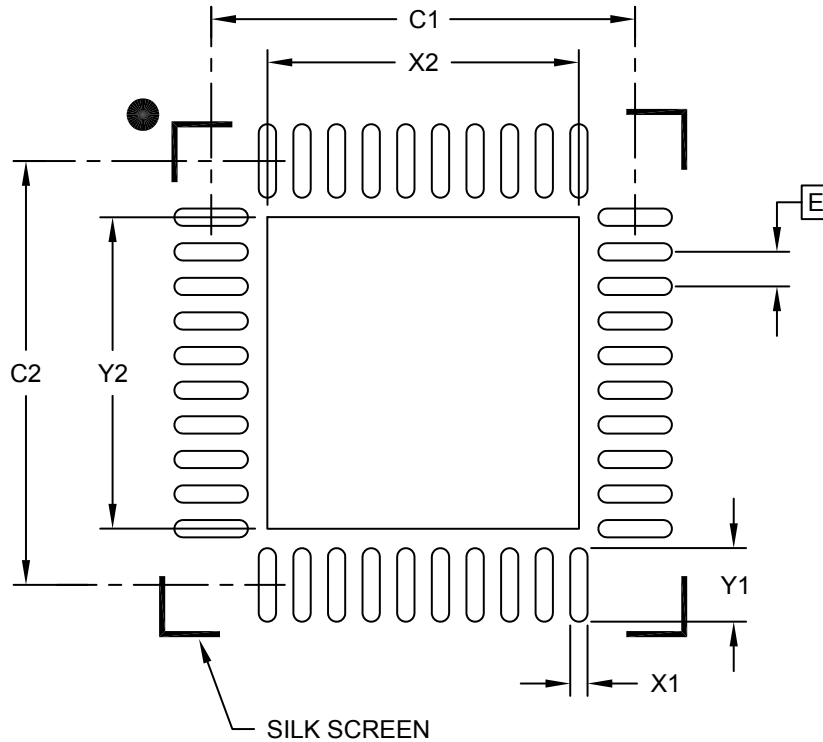

**RECOMMENDED LAND PATTERN**

Dimension Limits	Units	MILLIMETERS		
		MIN	NOM	MAX
Contact Pitch	E	0.40 BSC		
Optional Center Pad Width	X2			3.60
Optional Center Pad Length	Y2			3.60
Contact Pad Spacing	C1		4.90	
Contact Pad Spacing	C2		4.90	
Contact Pad Width (X40)	X1			0.20
Contact Pad Length (X40)	Y1			0.85

**Notes:**

1. Dimensioning and tolerancing per ASME Y14.5M

BSC: Basic Dimension. Theoretically exact value shown without tolerances.

Microchip Technology Drawing C04-2047-001A

**Package Outlines and Dimensions**

**40-Lead Plastic Quad Flat, No Lead Package (MP) - 5x5 mm Body [QFN]  
With 3.7x3.7 mm Exposed Pad**

**Note:** For the most current package drawings, please see the Microchip Packaging Specification located at <http://www.microchip.com/packaging>

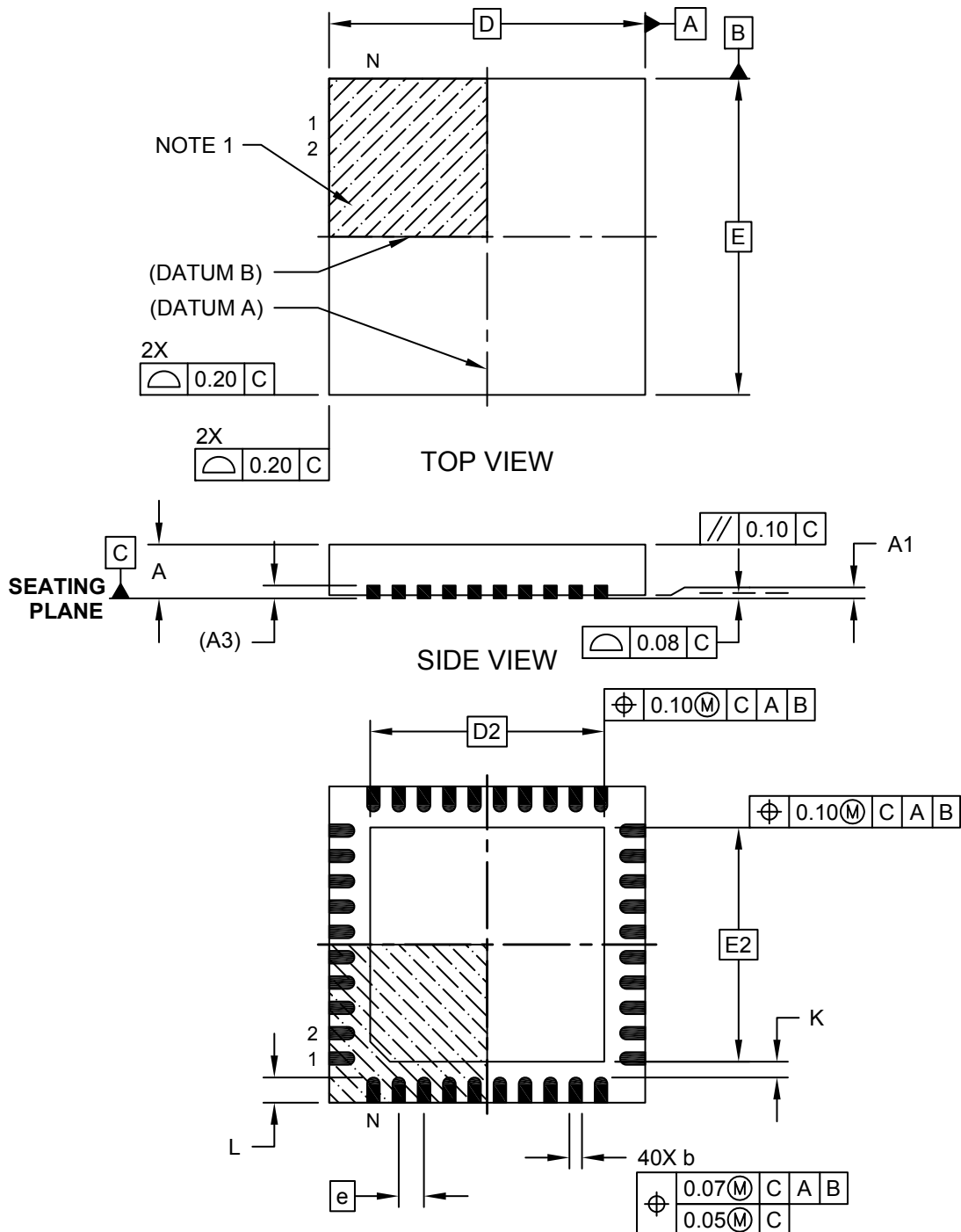

**Package Outlines and Dimensions**

**40-Lead Plastic Quad Flat, No Lead Package (MP) - 5x5 mm Body [QFN]  
With 3.7x3.7 mm Exposed Pad**

**Note:** For the most current package drawings, please see the Microchip Packaging Specification located at <http://www.microchip.com/packaging>

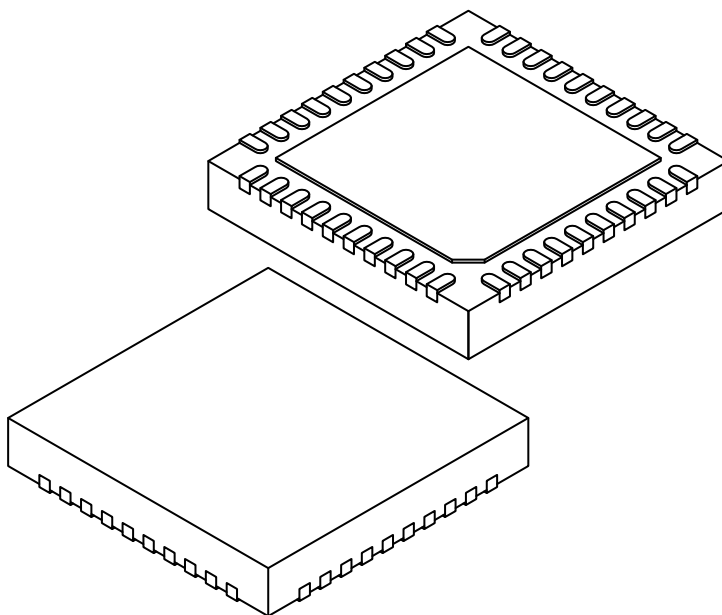

		MILLIMETERS		
Units				
Dimension Limits		MIN	NOM	MAX
Number of Terminals	N	40		
Pitch	e	0.40 BSC		
Overall Height	A	0.80	0.85	0.90
Standoff	A1	0.00	0.02	0.05
Terminal Thickness	A3	0.20 REF		
Overall Width	E	5.00 BSC		
Exposed Pad Width	E2	3.70 BSC		
Overall Length	D	5.00 BSC		
Exposed Pad Length	D2	3.70 BSC		
Terminal Width	b	0.15	0.20	0.25
Terminal Length	L	0.30	0.40	0.50
Terminal-to-Exposed-Pad	K	0.20	-	-

**Notes:**

1. Pin 1 visual index feature may vary, but must be located within the hatched area.
2. Package is saw singulated
3. Dimensioning and tolerancing per ASME Y14.5M

BSC: Basic Dimension. Theoretically exact value shown without tolerances.

REF: Reference Dimension, usually without tolerance, for information purposes only.

---



---

## Footprint Outlines and Dimensions

---



---

### 40-Lead Plastic Quad Flat, No Lead Package (MP) - 5x5 mm Body [QFN] With 3.7x3.7 mm Exposed Pad

**Note:** For the most current package drawings, please see the Microchip Packaging Specification located at <http://www.microchip.com/packaging>

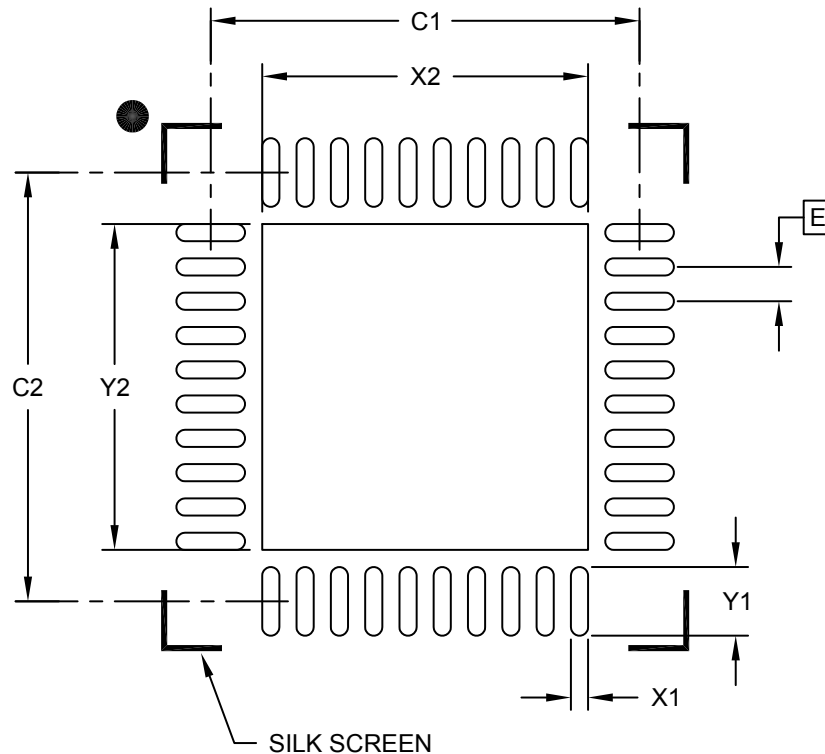

**RECOMMENDED LAND PATTERN**

Dimension Limits	Units	MILLIMETERS		
		MIN	NOM	MAX
Contact Pitch	E	0.40 BSC		
Optional Center Pad Width	X2			3.80
Optional Center Pad Length	Y2			3.80
Contact Pad Spacing	C1		5.00	
Contact Pad Spacing	C2		5.00	
Contact Pad Width (X40)	X1			0.20
Contact Pad Length (X40)	Y1			0.80

**Notes:**

1. Dimensioning and tolerancing per ASME Y14.5M

BSC: Basic Dimension. Theoretically exact value shown without tolerances.

Microchip Technology Drawing C04-2047-002A

**Package Outlines and Dimensions**

**44-Lead Plastic Quad Flat, No Lead Package (ML) - 8x8 mm Body [QFN or VQFN]**

**Note:** For the most current package drawings, please see the Microchip Packaging Specification located at <http://www.microchip.com/packaging>

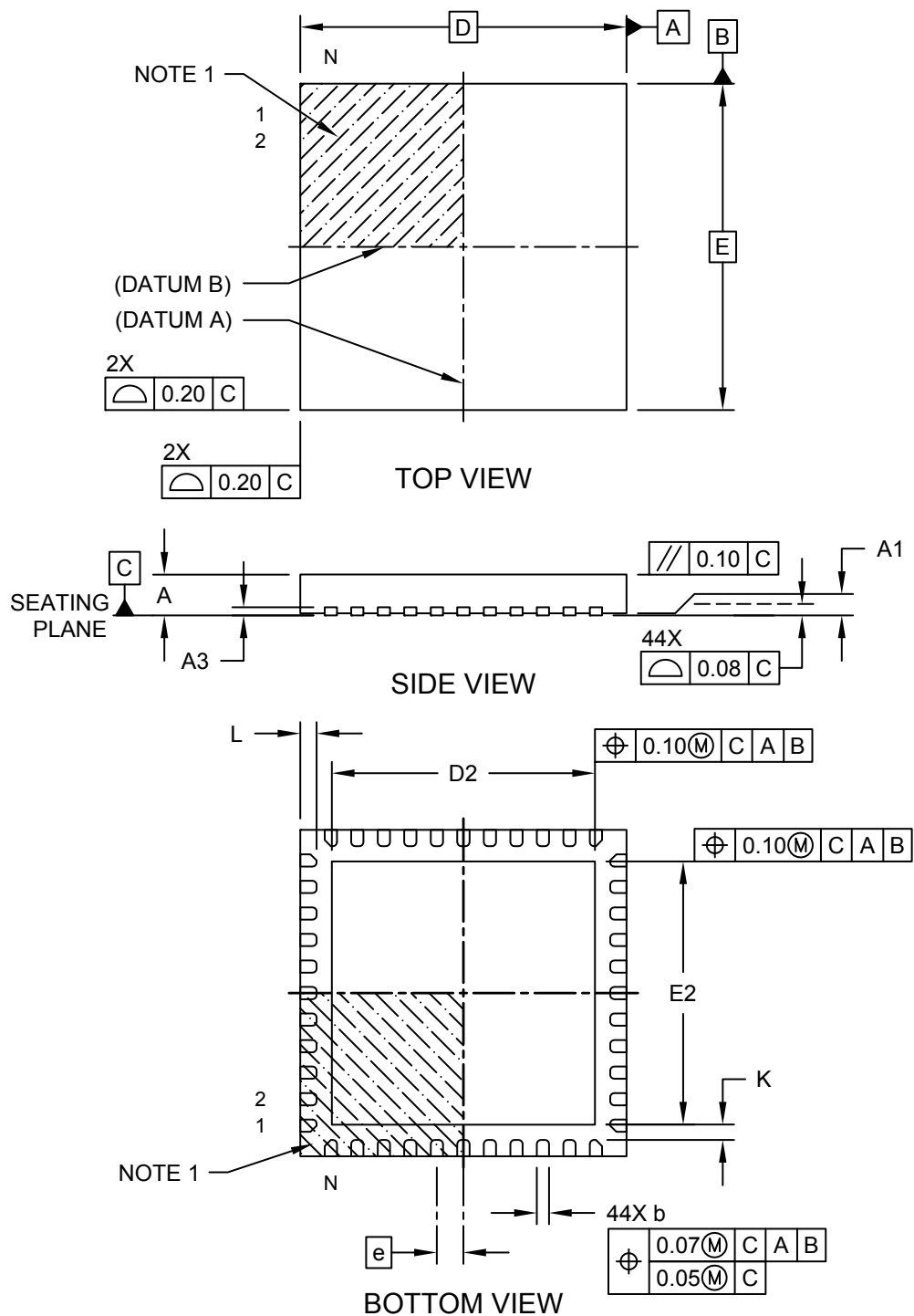

---



---

## Package Outlines and Dimensions

---



---

### 44-Lead Plastic Quad Flat, No Lead Package (ML) - 8x8 mm Body [QFN or VQFN]

**Note:** For the most current package drawings, please see the Microchip Packaging Specification located at <http://www.microchip.com/packaging>

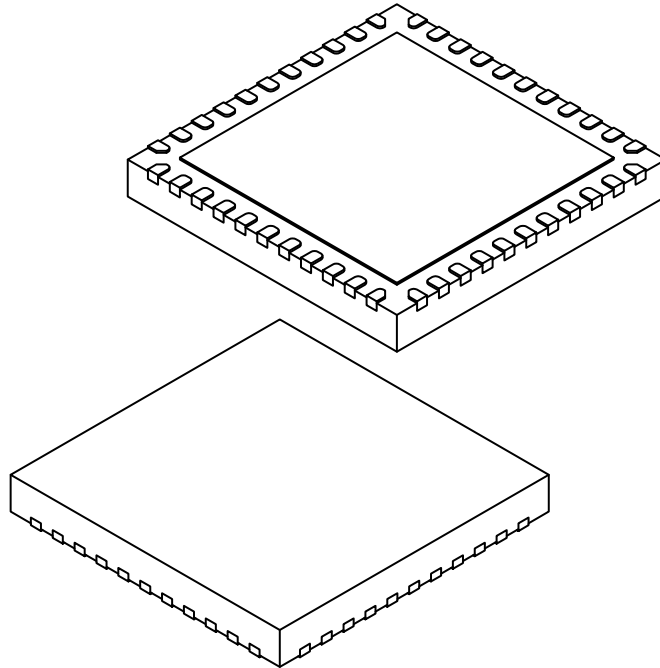

		Units	MILLIMETERS		
Dimension Limits			MIN	NOM	MAX
Number of Pins	N		44		
Pitch	e		0.65 BSC		
Overall Height	A		0.80	0.90	1.00
Standoff	A1		0.00	0.02	0.05
Terminal Thickness	A3		0.20 REF		
Overall Width	E		8.00 BSC		
Exposed Pad Width	E2		6.25	6.45	6.60
Overall Length	D		8.00 BSC		
Exposed Pad Length	D2		6.25	6.45	6.60
Terminal Width	b		0.20	0.30	0.35
Terminal Length	L		0.30	0.40	0.50
Terminal-to-Exposed-Pad	K		0.20	-	-

**Notes:**

1. Pin 1 visual index feature may vary, but must be located within the hatched area.
2. Package is saw singulated
3. Dimensioning and tolerancing per ASME Y14.5M
  - BSC: Basic Dimension. Theoretically exact value shown without tolerances.
  - REF: Reference Dimension, usually without tolerance, for information purposes only.

**Footprint Outlines and Dimensions**

**44-Lead Plastic Quad Flat, No Lead Package (ML) - 8x8 mm Body [QFN or VQFN]**

**Note:** For the most current package drawings, please see the Microchip Packaging Specification located at <http://www.microchip.com/packaging>

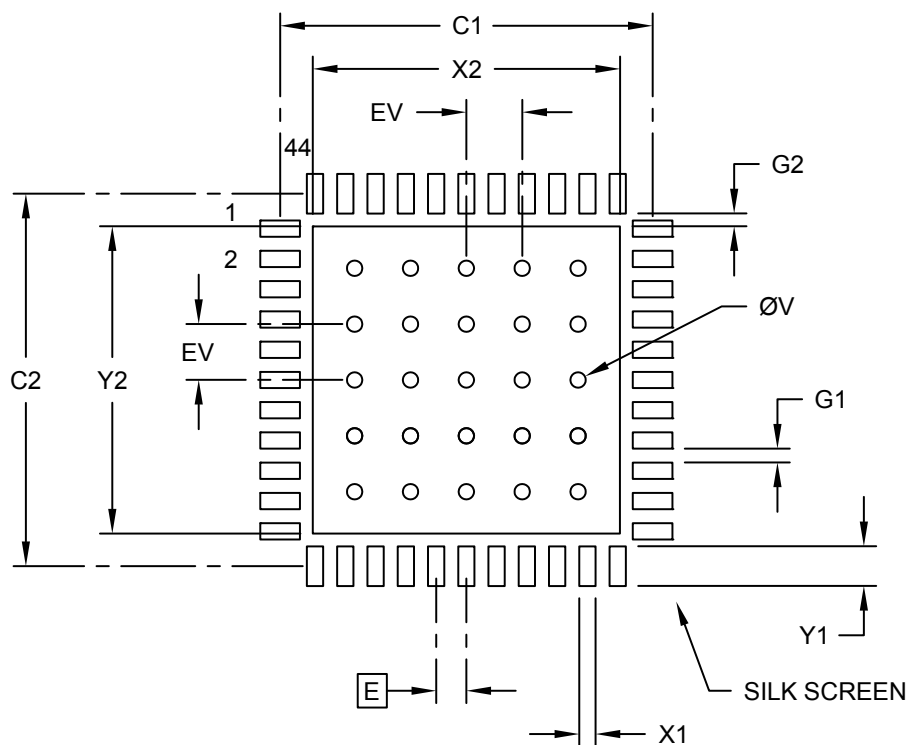

**RECOMMENDED LAND PATTERN**

		Units	MILLIMETERS		
Dimension Limits			MIN	NOM	MAX
Contact Pitch	E		0.65 BSC		
Optional Center Pad Width	X2				6.60
Optional Center Pad Length	Y2				6.60
Contact Pad Spacing	C1			8.00	
Contact Pad Spacing	C2			8.00	
Contact Pad Width (X44)	X1				0.35
Contact Pad Length (X44)	Y1				0.85
Contact Pad to Contact Pad (X40)	G1		0.30		
Contact Pad to Center Pad (X44)	G2		0.28		
Thermal Via Diameter	V			0.33	
Thermal Via Pitch	EV			1.20	

**Notes:**

- Dimensioning and tolerancing per ASME Y14.5M  
BSC: Basic Dimension. Theoretically exact value shown without tolerances.
- For best soldering results, thermal vias, if used, should be filled or tented to avoid solder loss during reflow process



**Package Outlines and Dimensions**

**48-Lead Plastic Quad Flat, No Lead Package (5E) - 7x7 mm Body [QFN]  
With 5.1x5.1 mm Exposed Pad; Punch Singulated, 0.40 mm Dimpled Terminals**

**Note:** For the most current package drawings, please see the Microchip Packaging Specification located at <http://www.microchip.com/packaging>

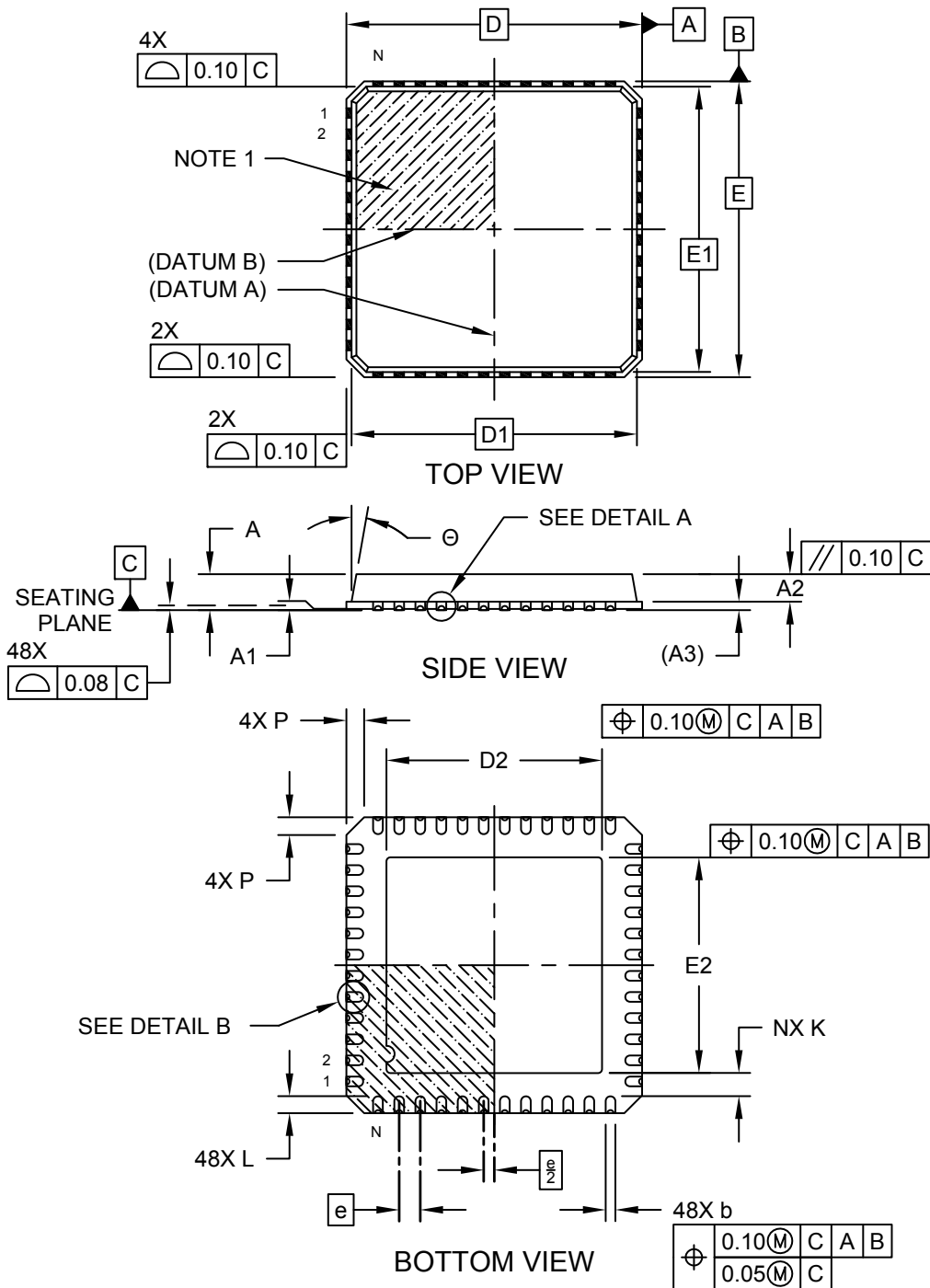

**Package Outlines and Dimensions**

**48-Lead Plastic Quad Flat, No Lead Package (5E) - 7x7 mm Body [QFN]  
With 5.1x5.1 mm Exposed Pad; Punch Singulated, 0.40 mm Dimpled Terminals**

**Note:** For the most current package drawings, please see the Microchip Packaging Specification located at <http://www.microchip.com/packaging>

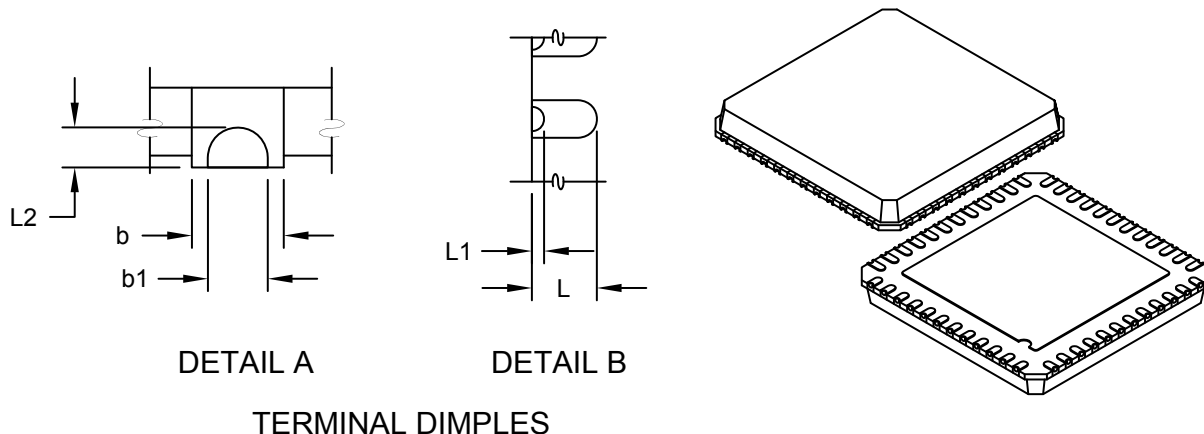

**TERMINAL DIMPLES**

Dimension Limits	Units	MILLIMETERS		
		MIN	NOM	MAX
Number of Terminals	N	48		
Pitch	e	0.50 BSC		
Overall Height	A	0.80	0.85	0.90
Standoff	A1	0.00	0.01	0.05
Mold Cap Height	A2	0.60	0.65	0.70
Terminal Thickness	(A3)	0.20 REF		
Overall Width	E	7.00 BSC		
Molded Top Width	E1	6.75 BSC		
Exposed Pad Width	E2	5.00	5.10	5.20
Overall Length	D	7.00 BSC		
Molded Top Length	D1	6.75 BSC		
Exposed Pad Length	D2	5.00	5.10	5.20
Corner Chamfer	P	0.24	0.42	0.60
Terminal Width	b	0.20	0.25	0.30
Terminal Dimple Width	b1	0.10	0.15	0.20
Terminal Length	L	0.30	0.40	0.50
Terminal Dimple Length (side)	L1	0.05	0.15	0.25
Terminal Dimple Length (bottom)	L2	0.05	0.10	0.15
Terminal-to-Exposed-Pad	K	0.20	-	-
Mold Draft Angle	$\theta$	0°	-	12°

**Notes:**

1. Pin 1 visual index feature may vary, but must be located within the hatched area.
2. Package is punch singulated
3. Dimensioning and tolerancing per ASME Y14.5M

BSC: Basic Dimension. Theoretically exact value shown without tolerances.

REF: Reference Dimension, usually without tolerance, for information purposes only.

---



---

## Footprint Outlines and Dimensions

---



---

### 48-Lead Plastic Quad Flat, No Lead Package (5E) - 7x7 mm Body [QFN] With 5.1x5.1 mm Exposed Pad; Punch Singulated, 0.40 mm Dimpled Terminals

**Note:** For the most current package drawings, please see the Microchip Packaging Specification located at <http://www.microchip.com/packaging>

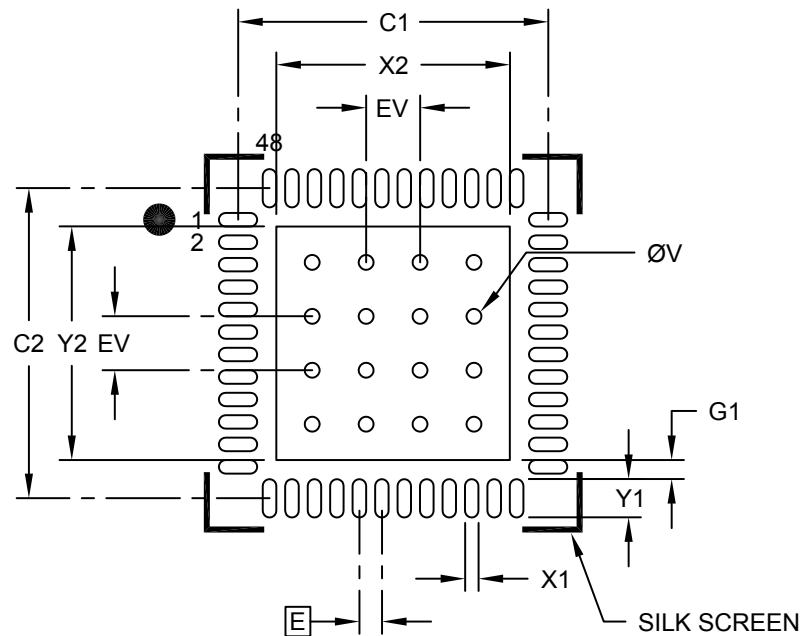

### RECOMMENDED LAND PATTERN

Dimension Limits	Units	MILLIMETERS		
		MIN	NOM	MAX
Contact Pitch	E	0.50 BSC		
Optional Center Pad Width	X2			5.20
Optional Center Pad Length	Y2			5.20
Contact Pad Spacing	C1		6.90	
Contact Pad Spacing	C2		6.90	
Contact Pad Width (X48)	X1			0.30
Contact Pad Length (X48)	Y1			0.85
Contact Pad to Center Pad (X44)	G1	0.20		
Thermal Via Diameter	V		0.33	
Thermal Via Pitch	EV		1.20	

**Notes:**

1. Dimensioning and tolerancing per ASME Y14.5M

BSC: Basic Dimension. Theoretically exact value shown without tolerances.

Microchip Technology Drawing C04-2363A

**Package Outlines and Dimensions**

**64-Lead Very Thin Plastic Quad Flat, No Lead Package (MR) – 9x9x0.9 mm Body [VQFN]  
With 7.15 x 7.15 Exposed Pad [Also called QFN]**

**Note:** For the most current package drawings, please see the Microchip Packaging Specification located at <http://www.microchip.com/packaging>

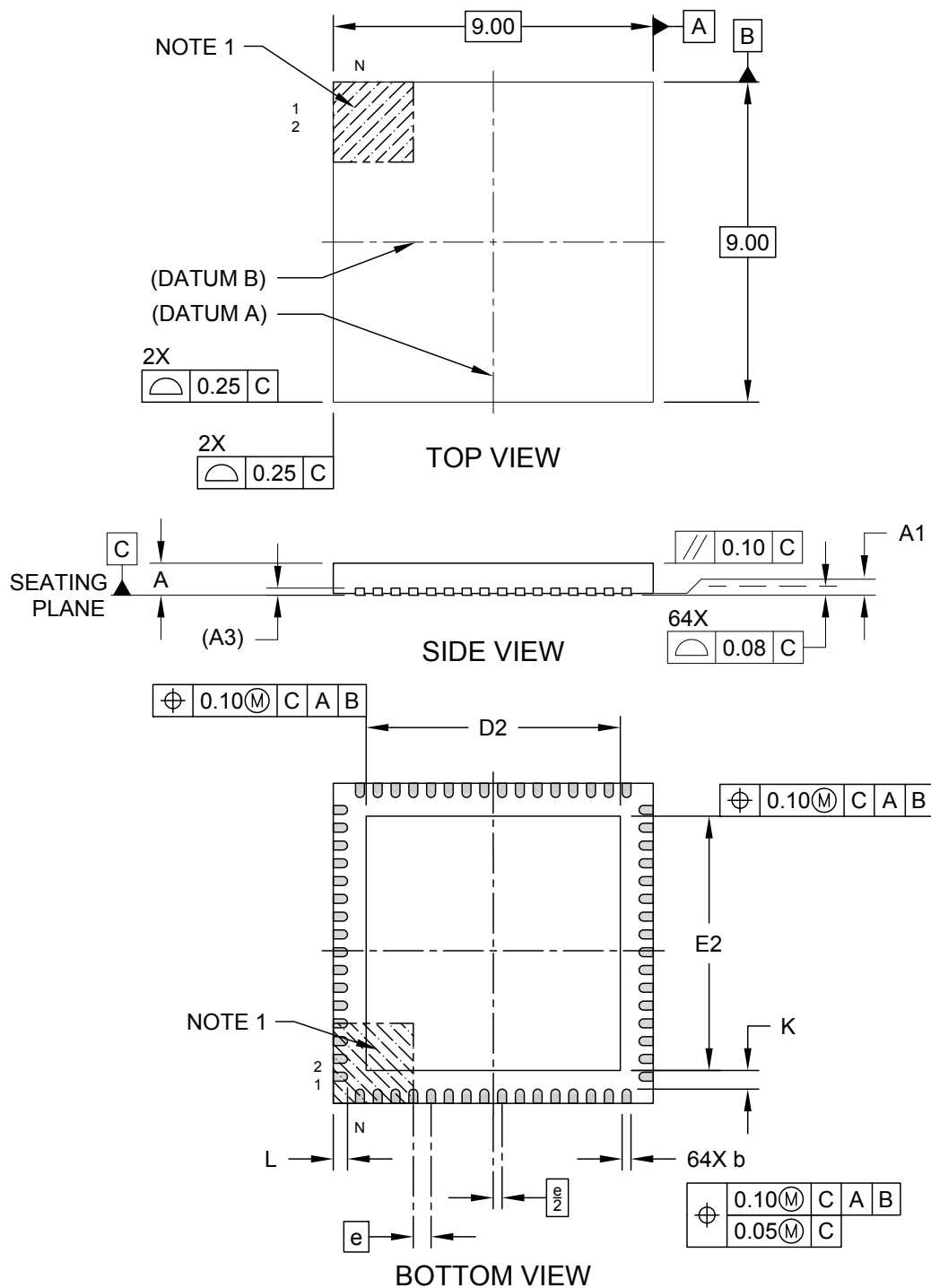

---



---

## Package Outlines and Dimensions

---



---

### 64-Lead Very Thin Plastic Quad Flat, No Lead Package (MR) – 9x9x0.9 mm Body [VQFN] With 7.15 x 7.15 Exposed Pad [Also called QFN]

**Note:** For the most current package drawings, please see the Microchip Packaging Specification located at <http://www.microchip.com/packaging>

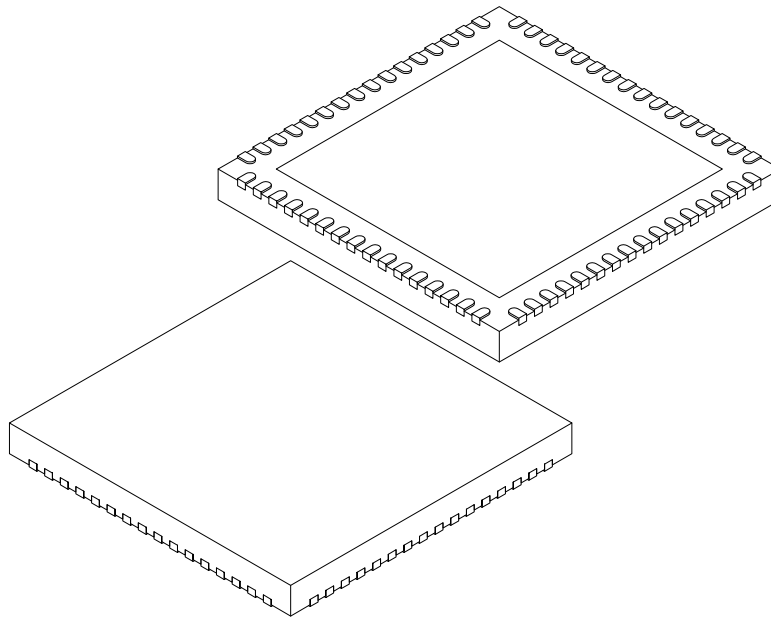

Dimension Limits		Units	MILLIMETERS		
			MIN	NOM	MAX
Number of Pins	N		64		
Pitch	e		0.50 BSC		
Overall Height	A	0.80	0.90	1.00	
Standoff	A1	0.00	0.02	0.05	
Contact Thickness	A3	0.20 REF			
Overall Width	E	9.00 BSC			
Exposed Pad Width	E2	7.05	7.15	7.25	
Overall Length	D	9.00 BSC			
Exposed Pad Length	D2	7.05	7.15	7.25	
Contact Width	b	0.18	0.25	0.30	
Contact Length	L	0.30	0.40	0.50	
Contact-to-Exposed Pad	K	0.20	-	-	

**Notes:**

1. Pin 1 visual index feature may vary, but must be located within the hatched area.
2. Package is saw singulated
3. Dimensioning and tolerancing per ASME Y14.5M

BSC: Basic Dimension. Theoretically exact value shown without tolerances.

REF: Reference Dimension, usually without tolerance, for information purposes only.

**Footprint Outlines and Dimensions**

**64-Lead Very Thin Plastic Quad Flat, No Lead Package (MR) – 9x9x0.9 mm Body [VQFN]  
With 7.15 x 7.15 Exposed Pad [Also called QFN]**

**Note:** For the most current package drawings, please see the Microchip Packaging Specification located at <http://www.microchip.com/packaging>

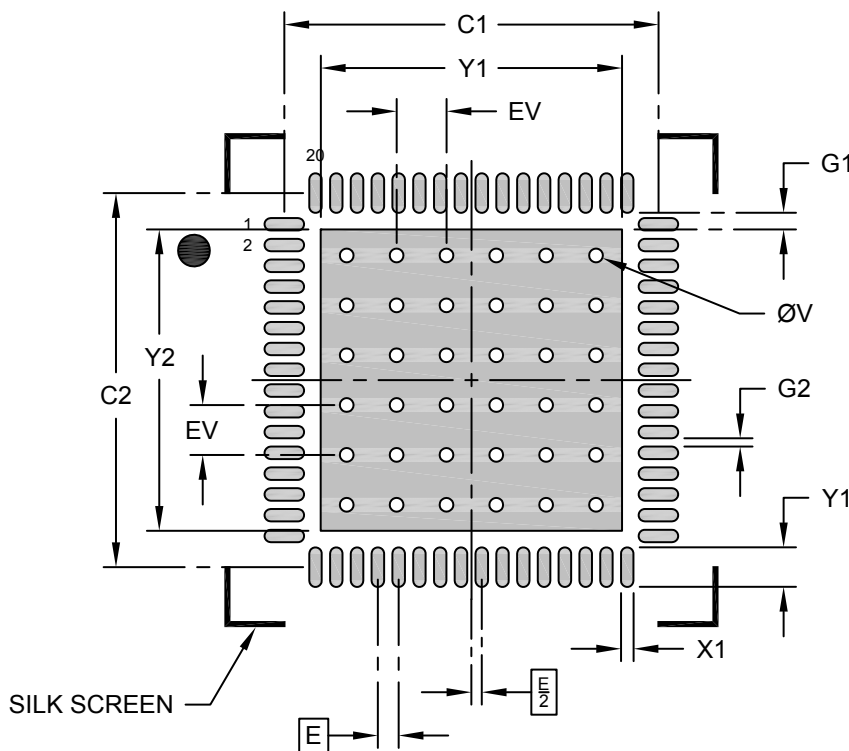

**RECOMMENDED LAND PATTERN**

Dimension Limits	Units	MILLIMETERS		
		MIN	NOM	MAX
Contact Pitch	E	0.50 BSC		
Optional Center Pad Width	X2			7.25
Optional Center Pad Length	Y2			7.25
Contact Pad Spacing	C1		9.00	
Contact Pad Spacing	C2		9.00	
Contact Pad Width (X64)	X1			0.30
Contact Pad Length (X64)	Y1			0.95
Contact Pad to Center Pad (X64)	G1	0.40		
Spacing Between Contact Pads (X60)	G2	0.20		
Thermal Via Diameter	V		0.33	
Thermal Via Pitch	EV		1.20	

**Notes:**

1. Dimensioning and tolerancing per ASME Y14.5M  
BSC: Basic Dimension. Theoretically exact value shown without tolerances.
2. For best soldering results, thermal vias, if used, should be filled or tented to avoid solder loss during reflow process

**Package Outlines and Dimensions**

**64-Lead Very Thin Plastic Quad Flat, No Lead Package (R4X) – 9x9x0.9 mm Body [VQFN]  
With 7.15 x 7.15 Exposed Pad [Also called QFN]**

**Note:** For the most current package drawings, please see the Microchip Packaging Specification located at <http://www.microchip.com/packaging>

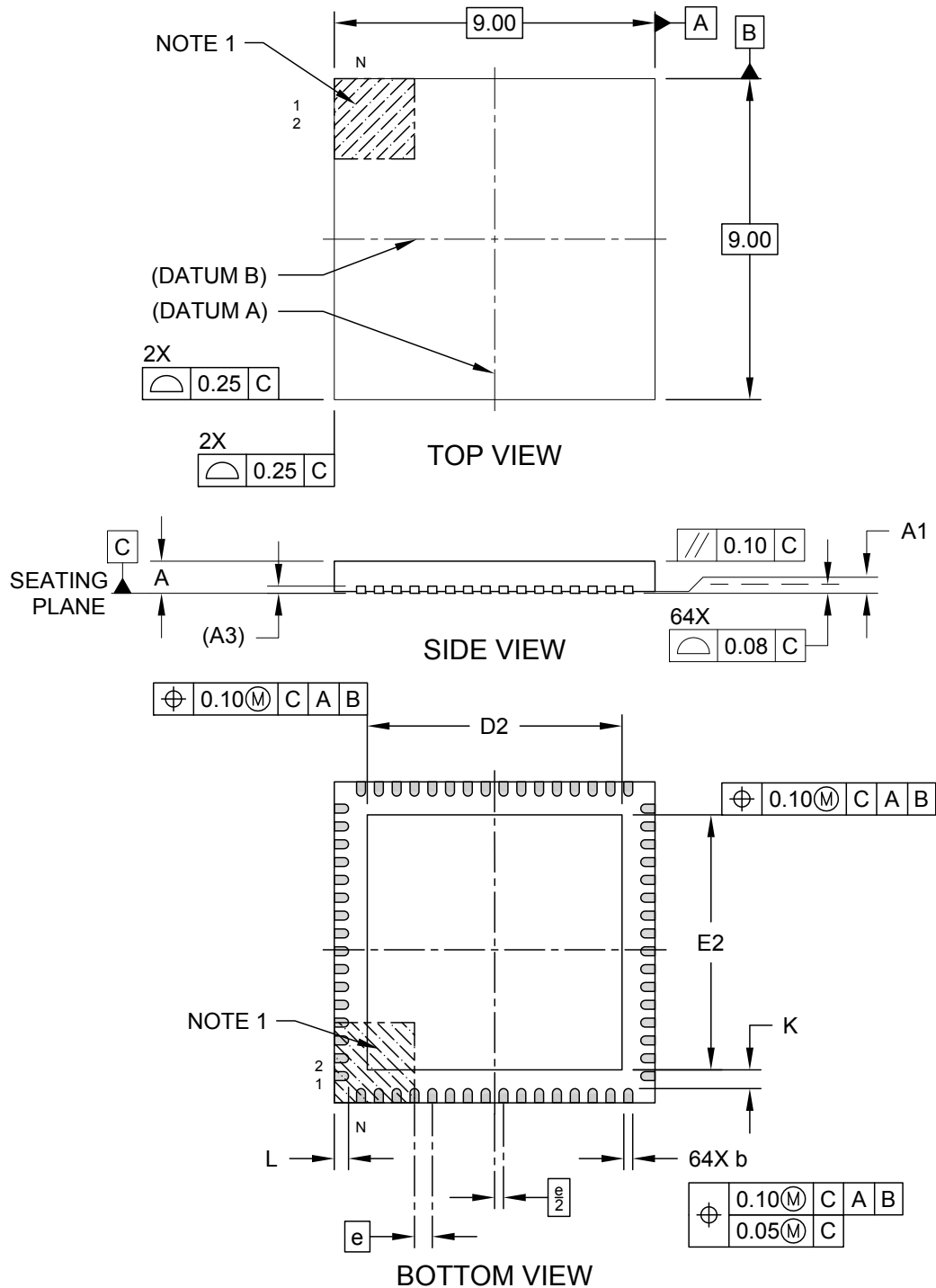

**Package Outlines and Dimensions**

**64-Lead Very Thin Plastic Quad Flat, No Lead Package (R4X) – 9x9x0.9 mm Body [VQFN]  
With 7.15 x 7.15 Exposed Pad [Also called QFN]**

**Note:** For the most current package drawings, please see the Microchip Packaging Specification located at <http://www.microchip.com/packaging>

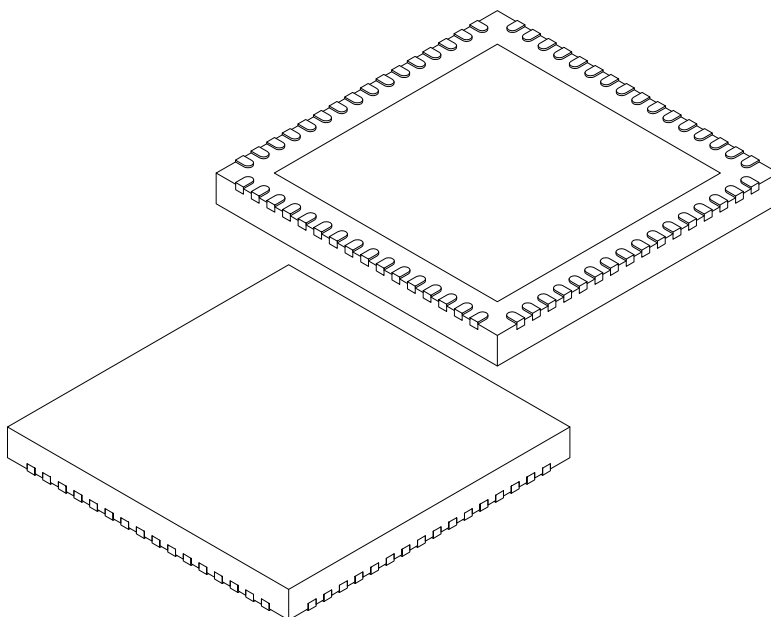

Dimension Limits	Units	MILLIMETERS		
		MIN	NOM	MAX
Number of Pins	N	64		
Pitch	e	0.50 BSC		
Overall Height	A	0.80	0.90	1.00
Standoff	A1	0.00	0.02	0.05
Contact Thickness	A3	0.20 REF		
Overall Width	E	9.00 BSC		
Exposed Pad Width	E2	7.05	7.15	7.25
Overall Length	D	9.00 BSC		
Exposed Pad Length	D2	7.05	7.15	7.25
Contact Width	b	0.18	0.25	0.30
Contact Length	L	0.30	0.40	0.50
Contact-to-Exposed Pad	K	0.20	-	-

**Notes:**

- Pin 1 visual index feature may vary, but must be located within the hatched area.
- Package is saw singulated
- Dimensioning and tolerancing per ASME Y14.5M
  - BSC: Basic Dimension. Theoretically exact value shown without tolerances.
  - REF: Reference Dimension, usually without tolerance, for information purposes only.



---



---

## Footprint Outlines and Dimensions

---



---

### 64-Lead Very Thin Plastic Quad Flat, No Lead Package (R4X) – 9x9x0.9 mm Body [VQFN] With 7.15 x 7.15 Exposed Pad [Also called QFN]

**Note:** For the most current package drawings, please see the Microchip Packaging Specification located at <http://www.microchip.com/packaging>

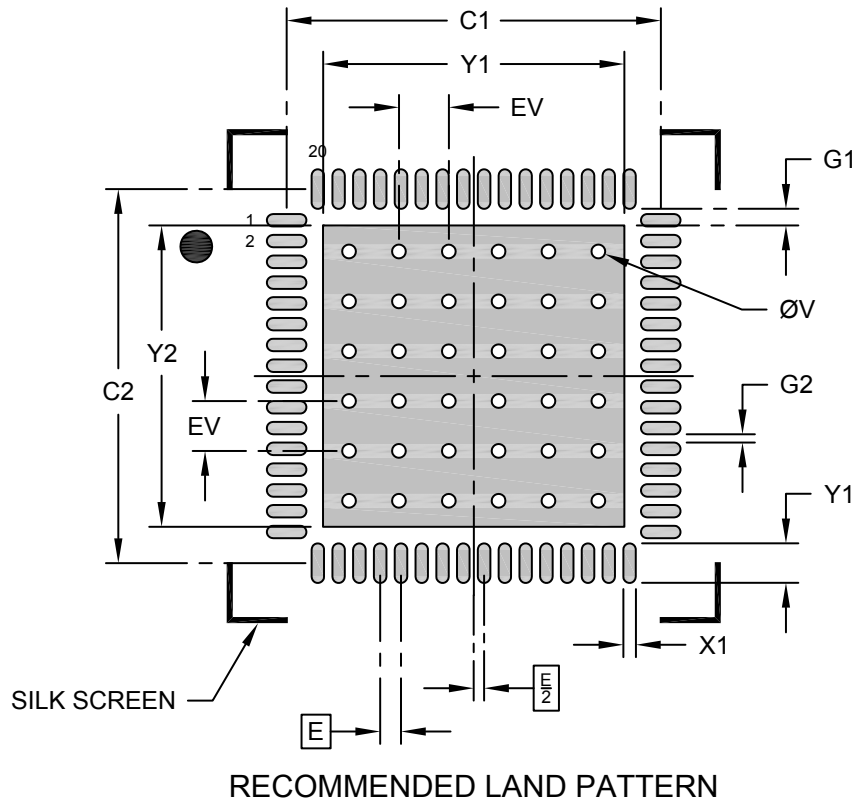

Dimension Limits	Units	MILLIMETERS		
		MIN	NOM	MAX
Contact Pitch	E	0.50 BSC		
Optional Center Pad Width	X2			7.25
Optional Center Pad Length	Y2			7.25
Contact Pad Spacing	C1		9.00	
Contact Pad Spacing	C2		9.00	
Contact Pad Width (X64)	X1			0.30
Contact Pad Length (X64)	Y1			0.95
Contact Pad to Center Pad (X64)	G1	0.40		
Spacing Between Contact Pads (X60)	G2	0.20		
Thermal Via Diameter	V		0.33	
Thermal Via Pitch	EV		1.20	

**Notes:**

1. Dimensioning and tolerancing per ASME Y14.5M  
BSC: Basic Dimension. Theoretically exact value shown without tolerances.
2. For best soldering results, thermal vias, if used, should be filled or tented to avoid solder loss during reflow process

**Package Outlines and Dimensions**

**64-Lead Plastic Quad Flat, No Lead Package (MR) – 9x9x0.9 mm Body with 5.40 x 5.40 Exposed Pad [QFN]**

**Note:** For the most current package drawings, please see the Microchip Packaging Specification located at <http://www.microchip.com/packaging>

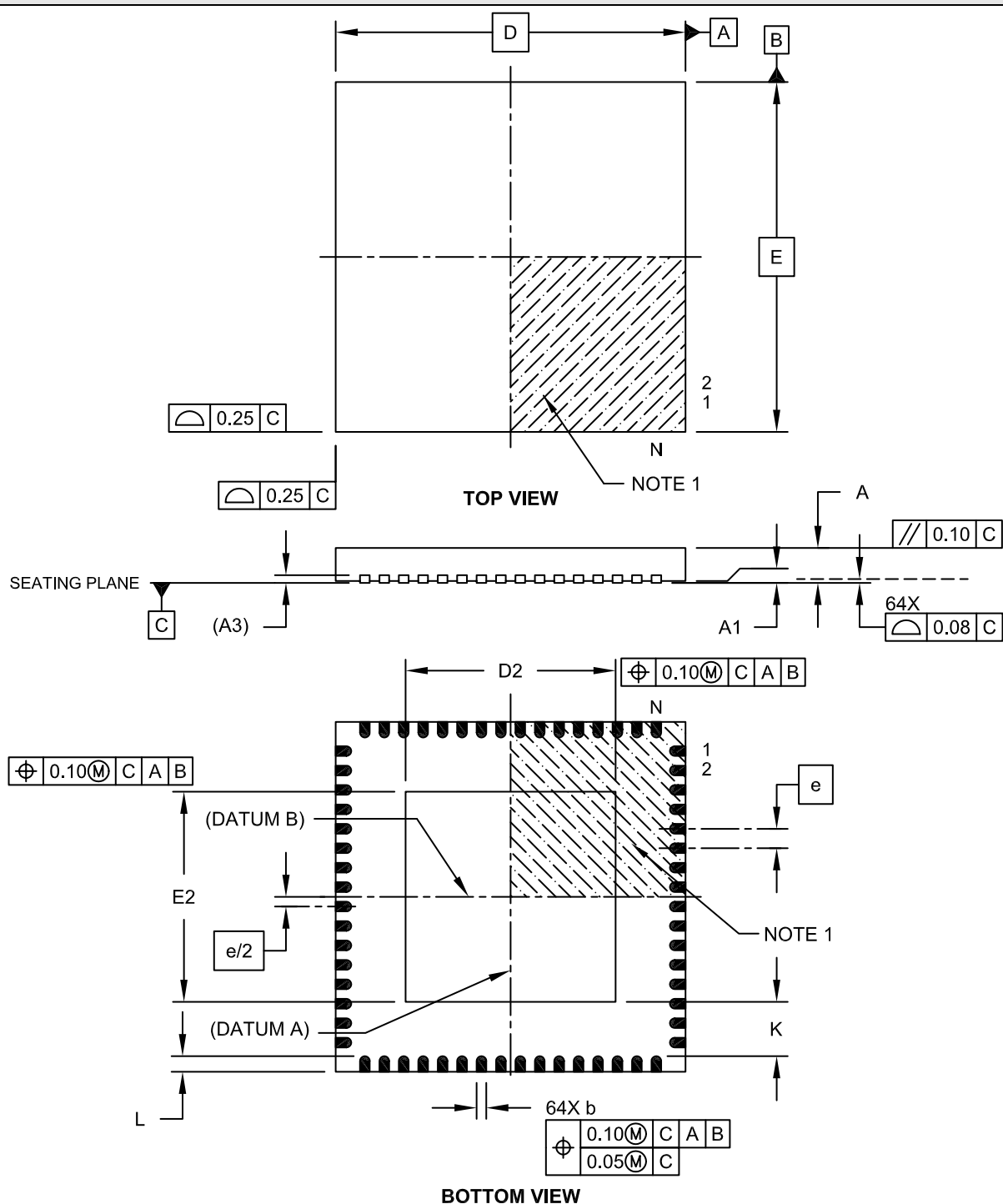

---



---

## Package Outlines and Dimensions

---



---

### 64-Lead Plastic Quad Flat, No Lead Package (MR) – 9x9x0.9 mm Body with 5.40 x 5.40 Exposed Pad [QFN]

**Note:** For the most current package drawings, please see the Microchip Packaging Specification located at <http://www.microchip.com/packaging>

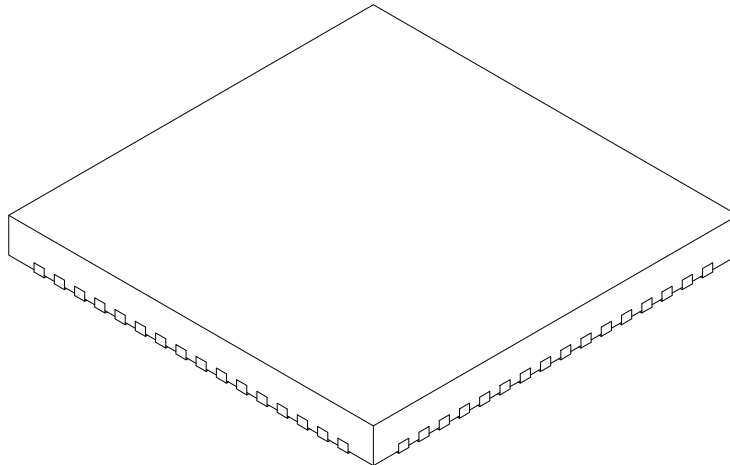

Dimension Limits	Units	MILLIMETERS		
		MIN	NOM	MAX
Number of Pins	N	64		
Pitch	e	0.50 BSC		
Overall Height	A	0.80	0.90	1.00
Standoff	A1	0.00	0.02	0.05
Contact Thickness	A3	0.20 REF		
Overall Width	E	9.00 BSC		
Exposed Pad Width	E2	5.30	5.40	5.50
Overall Length	D	9.00 BSC		
Exposed Pad Length	D2	5.30	5.40	5.50
Contact Width	b	0.20	0.25	0.30
Contact Length	L	0.30	0.40	0.50
Contact-to-Exposed Pad	K	0.20	-	-

**Notes:**

1. Pin 1 visual index feature may vary, but must be located within the hatched area.
2. Package is saw singulated.
3. Dimensioning and tolerancing per ASME Y14.5M.

BSC: Basic Dimension. Theoretically exact value shown without tolerances.

REF: Reference Dimension, usually without tolerance, for information purposes only.

**Footprint Outlines and Dimensions**

64-Lead Plastic Quad Flat, No Lead Package (MR) – 9x9x0.9 mm Body [QFN]  
 With 0.40 mm Contact Length and 5.40x5.40mm Exposed Pad

**Note:** For the most current package drawings, please see the Microchip Packaging Specification located at <http://www.microchip.com/packaging>

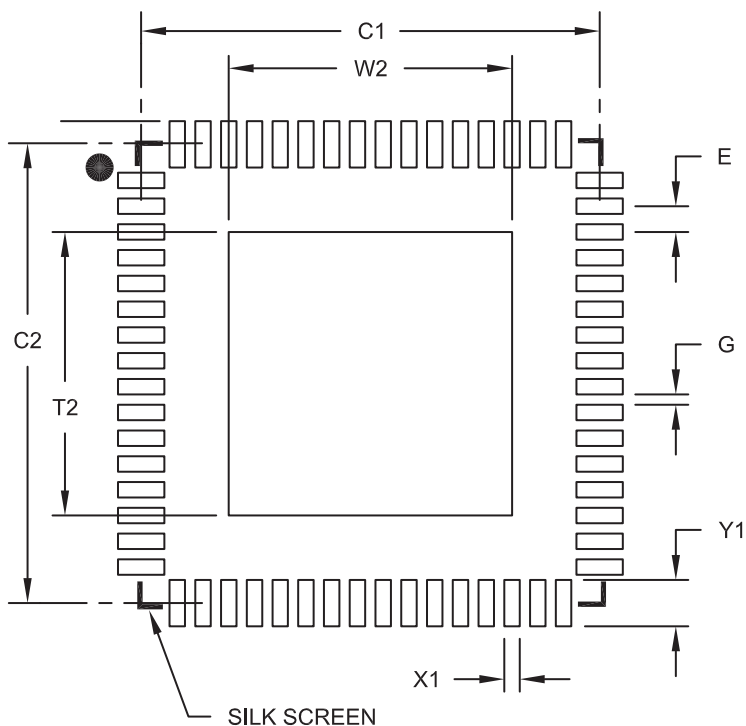

**RECOMMENDED LAND PATTERN**

Dimension Limits	Units	MILLIMETERS		
		MIN	NOM	MAX
Contact Pitch	E	0.50 BSC		
Optional Center Pad Width	W2			5.50
Optional Center Pad Length	T2			5.50
Contact Pad Spacing	C1		8.90	
Contact Pad Spacing	C2		8.90	
Contact Pad Width (X64)	X1			0.30
Contact Pad Length (X64)	Y1			0.85
Distance Between Pads	G	0.20		

Notes:

1. Dimensioning and tolerancing per ASME Y14.5M

BSC: Basic Dimension. Theoretically exact value shown without tolerances.

Microchip Technology Drawing No. C04-2154A

**Package Outlines and Dimensions**

**64-Lead Plastic Quad Flat, No Lead Package (MR) – 9x9x0.9 mm Body [QFN]  
With 7.70 x 7.70 Exposed Pad [QFN]**

**Note:** For the most current package drawings, please see the Microchip Packaging Specification located at <http://www.microchip.com/packaging>

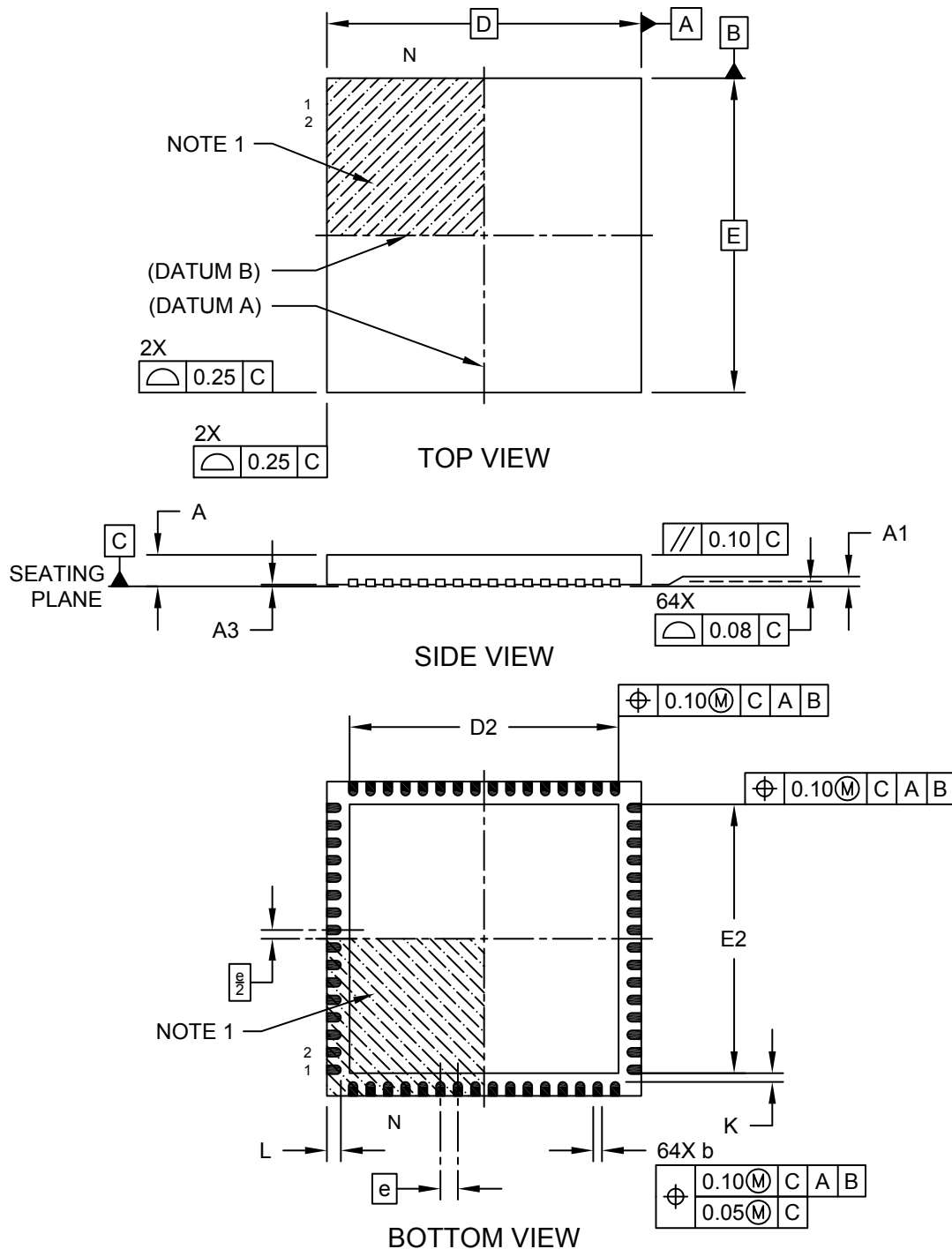

**Package Outlines and Dimensions**

**64-Lead Plastic Quad Flat, No Lead Package (MR) – 9x9x0.9 mm Body [QFN]  
With 7.70 x 7.70 Exposed Pad [QFN]**

**Note:** For the most current package drawings, please see the Microchip Packaging Specification located at <http://www.microchip.com/packaging>

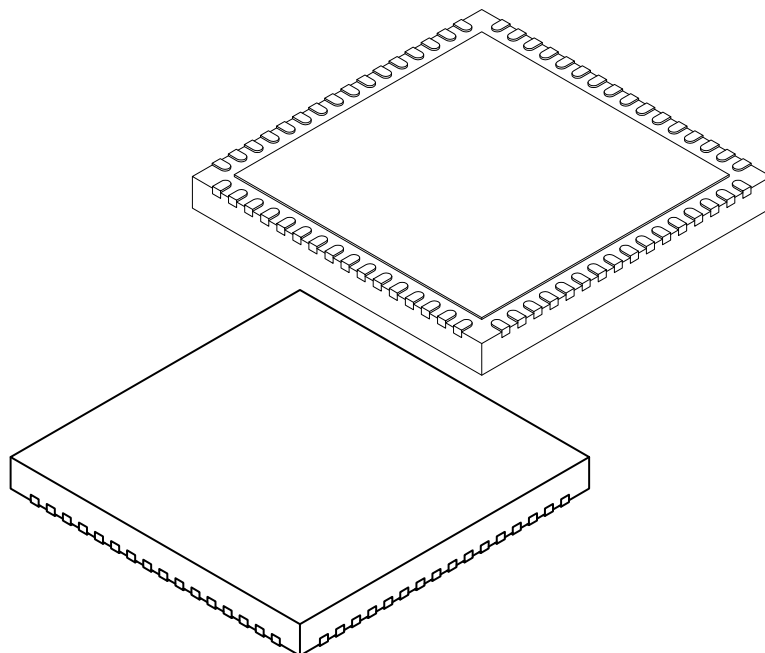

Dimension Limits	Units	MILLIMETERS		
		MIN	NOM	MAX
Number of Pins	N	64		
Pitch	e	0.50 BSC		
Overall Height	A	0.80	0.85	0.90
Standoff	A1	0.00	0.02	0.05
Contact Thickness	A3	0.20 REF		
Overall Width	E	9.00 BSC		
Exposed Pad Width	E2	7.60	7.70	7.80
Overall Length	D	9.00 BSC		
Exposed Pad Length	D2	7.60	7.70	7.80
Contact Width	b	0.20	0.25	0.30
Contact Length	L	0.30	0.40	0.50
Contact-to-Exposed Pad	K	0.20	-	-

**Notes:**

- Pin 1 visual index feature may vary, but must be located within the hatched area.
- Package is saw singulated.
- Dimensioning and tolerancing per ASME Y14.5M.  
BSC: Basic Dimension. Theoretically exact value shown without tolerances.  
REF: Reference Dimension, usually without tolerance, for information purposes only.

---



---

## Footprint Outlines and Dimensions

---



---

64-Lead Plastic Quad Flat, No Lead Package (MR) – 9x9x0.9 mm Body [QFN]  
 With 0.40 mm Contact Length and 7.70x7.70mm Exposed Pad

**Note:** For the most current package drawings, please see the Microchip Packaging Specification located at <http://www.microchip.com/packaging>

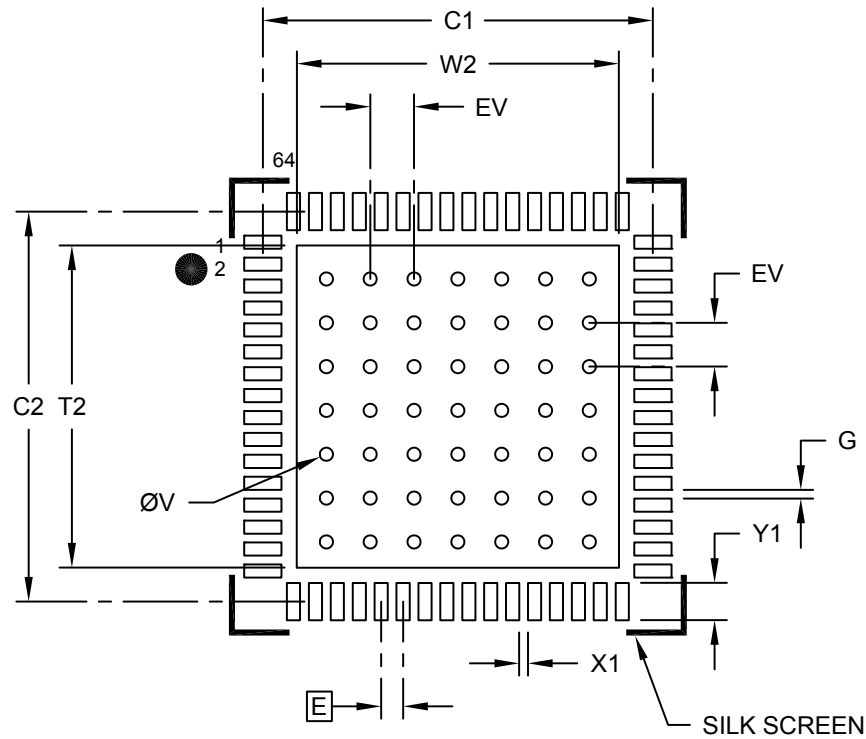

### RECOMMENDED LAND PATTERN

	Units	MILLIMETERS		
		MIN	NOM	MAX
Dimension Limits				
Contact Pitch	E	0.50 BSC		
Optional Center Pad Width	W2			7.50
Optional Center Pad Length	T2			7.50
Contact Pad Spacing	C1		8.90	
Contact Pad Spacing	C2		8.90	
Contact Pad Width (X20)	X1			0.30
Contact Pad Length (X20)	Y1			0.90
Contact Pad to Center Pad (X20)	G	0.20		
Thermal Via Diameter	V		0.30	
Thermal Via Pitch	EV		1.00	

**Notes:**

1. Dimensioning and tolerancing per ASME Y14.5M  
     BSC: Basic Dimension. Theoretically exact value shown without tolerances.
2. For best soldering results, thermal vias, if used, should be filled or tented to avoid solder loss during reflow process

Microchip Technology Drawing No. C04-2213B

**Package Outlines and Dimensions**

**64-Terminal Plastic Quad Flat Pack, No Lead (RG) 9x9x0.9 mm Body [QFN]  
Saw Singulated**

**Note:** For the most current package drawings, please see the Microchip Packaging Specification located at <http://www.microchip.com/packaging>

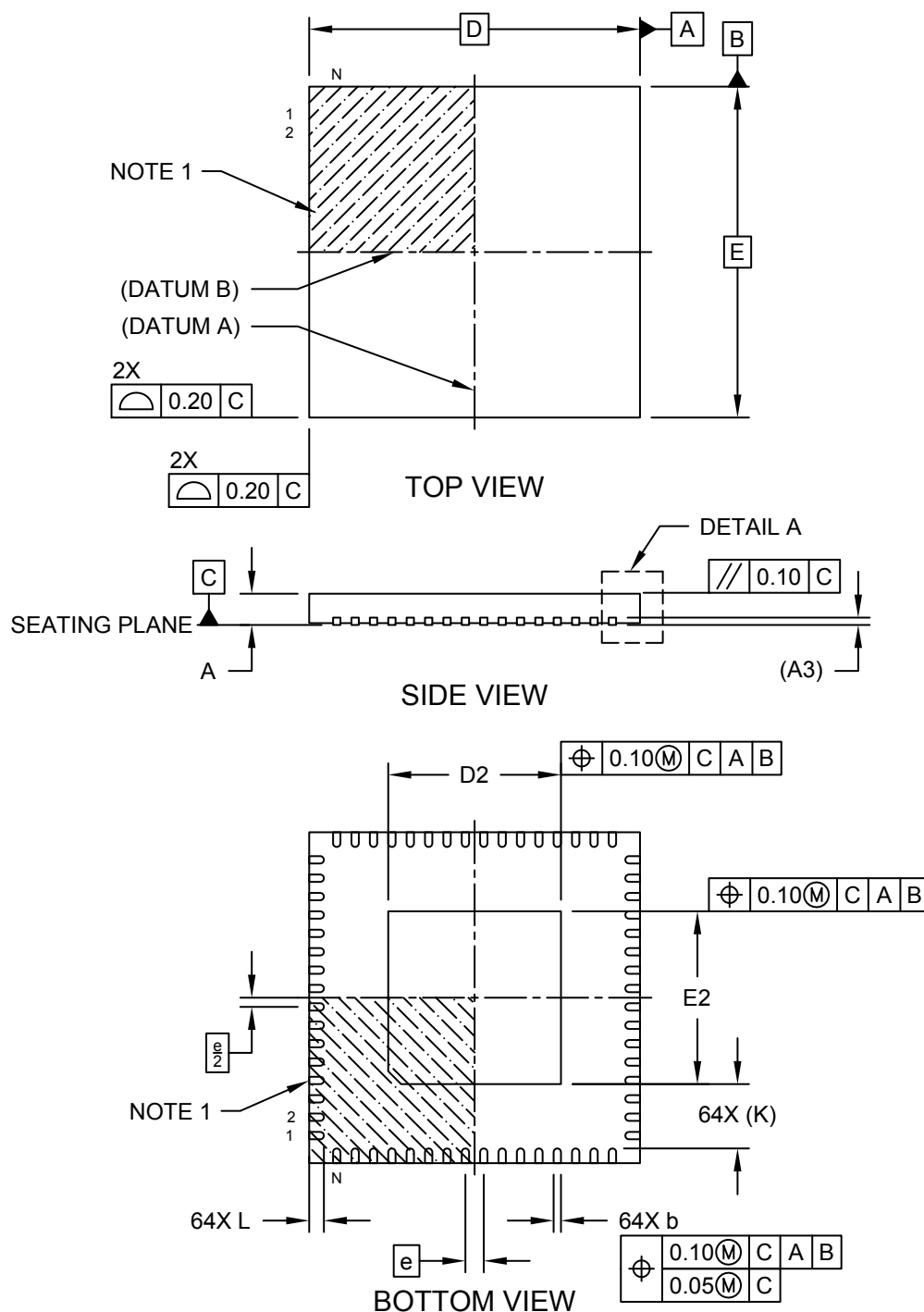



---



---

## Package Outlines and Dimensions

---



---

### 64-Terminal Plastic Quad Flat Pack, No Lead (RG) 9x9x0.9 mm Body [QFN] Saw Singulated

**Note:** For the most current package drawings, please see the Microchip Packaging Specification located at <http://www.microchip.com/packaging>

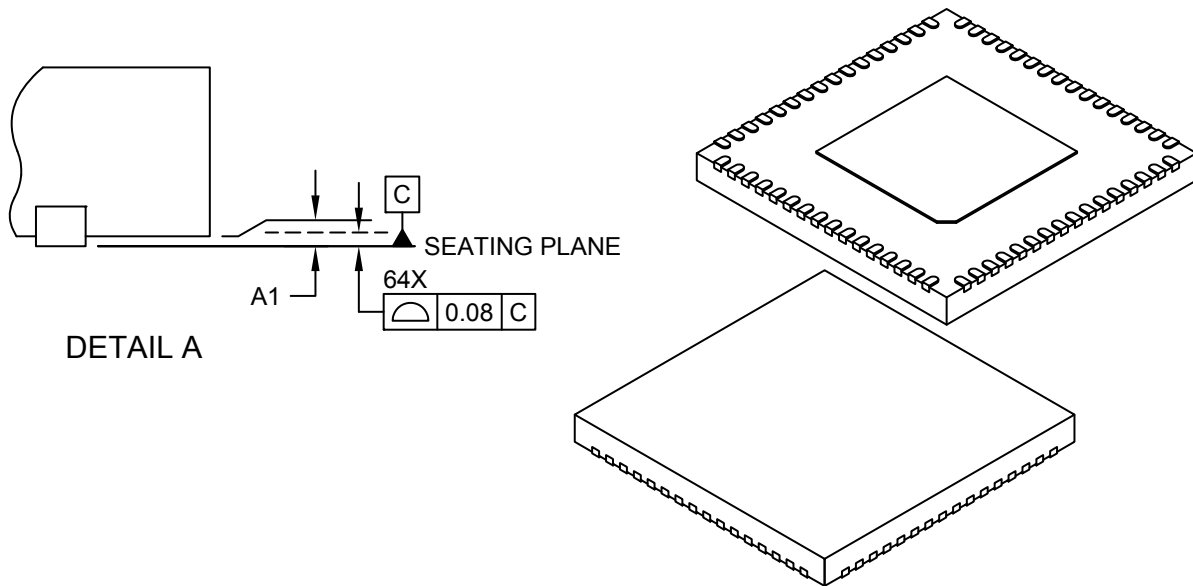

		MILLIMETERS		
Units				
Dimension Limits		MIN	NOM	MAX
Number of Terminals	N	64		
Pitch	e	0.50 BSC		
Overall Height	A	0.80	0.85	0.90
Standoff	A1	0.00	0.02	0.05
Standoff	A3	0.20 REF		
Overall Width	E	9.00 BSC		
Exposed Pad Width	E2	4.60	4.70	4.80
Overall Length	D	9.00 BSC		
Exposed Pad Length	D2	4.60	4.70	4.80
Terminal Width	b	0.15	0.20	0.25
Terminal Length	L	0.30	0.40	0.50
Terminal-to-Exposed-Pad	K	1.755 REF		

**Notes:**

1. Pin 1 visual index feature may vary, but must be located within the hatched area.
2. Package is saw singulated
3. Dimensioning and tolerancing per ASME Y14.5M

BSC: Basic Dimension. Theoretically exact value shown without tolerances.

REF: Reference Dimension, usually without tolerance, for information purposes only.

**Footprint Outlines and Dimensions**

**64-Lead Very Thin Plastic Quad Flat, No Lead Package (RG) - 9x9x1.0 mm Body [QFN]  
4.7x4.7 mm Exposed Pad**

**Note:** For the most current package drawings, please see the Microchip Packaging Specification located at <http://www.microchip.com/packaging>

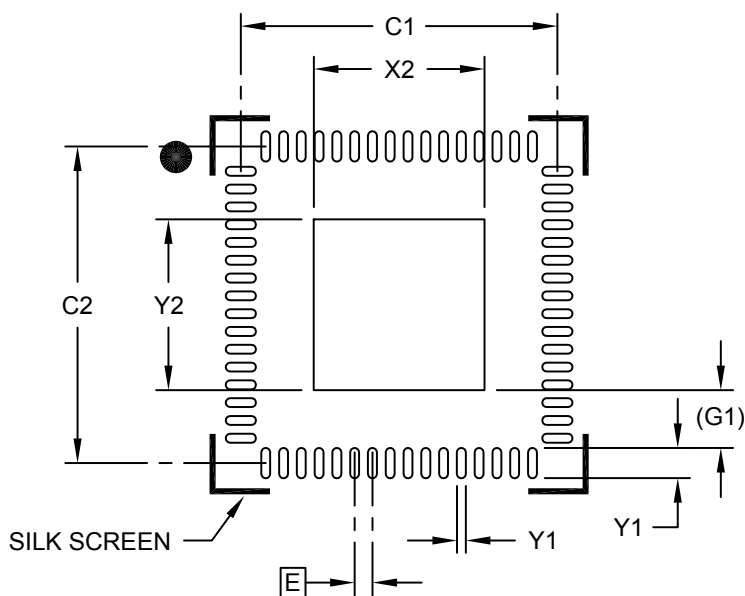

**RECOMMENDED LAND PATTERN**

Dimension Limits	Units	MILLIMETERS		
		MIN	NOM	MAX
Contact Pitch	E	0.50 BSC		
Optional Center Pad Width	X2			4.80
Optional Center Pad Length	Y2			4.80
Contact Pad Spacing	C1		8.90	
Contact Pad Spacing	C2		8.90	
Contact Pad Width (X64)	X1			0.25
Contact Pad Length (X64)	Y1			0.85
Contact Pad to Center Pad (X64)	G1	1.625 REF		

Notes:

1. Dimensioning and tolerancing per ASME Y14.5M

BSC: Basic Dimension. Theoretically exact value shown without tolerances.

Microchip Technology Drawing C04-2260A

**Package Outlines and Dimensions**

**72-Lead Plastic Quad Flat, No Lead Package (6E) - 10x10 mm Body [VQFN]  
6.0x6.0 mm Exposed Pad; Punch Singulated, Dimpled Terminals (Also called QFN)**

**Note:** For the most current package drawings, please see the Microchip Packaging Specification located at <http://www.microchip.com/packaging>

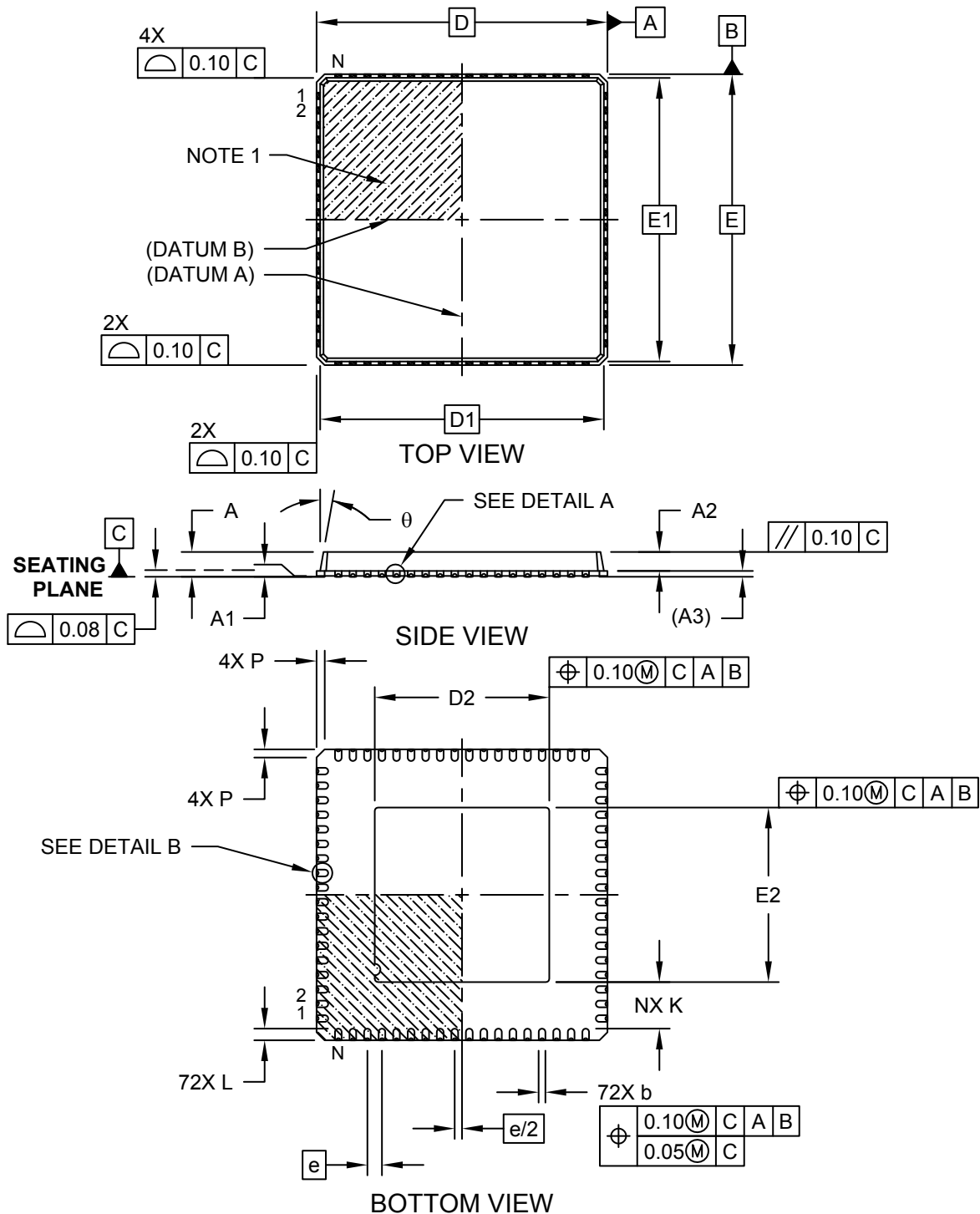

Microchip Technology Drawing C04-243B Sheet 1 of 2

**Package Outlines and Dimensions**

**72-Lead Plastic Quad Flat, No Lead Package (6E) - 10x10 mm Body [VQFN] 6.0x6.0 mm Exposed Pad; Punch Singulated, Dimpled Terminals (Also called QFN)**

**Note:** For the most current package drawings, please see the Microchip Packaging Specification located at <http://www.microchip.com/packaging>

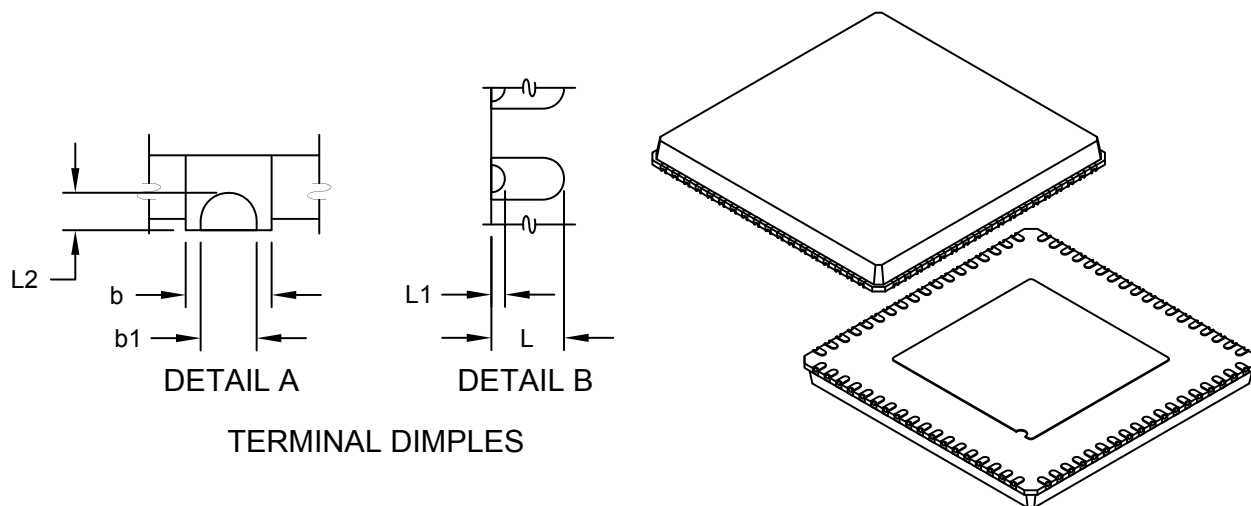

TERMINAL DIMPLES

		Units			
		MILLIMETERS			
	Dimension	Limits	MIN	NOM	MAX
Number of Pins	N		72		
Pitch	e		0.50 BSC		
Overall Height	A		0.80	0.85	0.90
Standoff	A1		0.00	0.01	0.05
Mold Cap Height	A2		0.60	0.65	0.70
Terminal Thickness	A3		0.20 REF		
Overall Width	E		10.00 BSC		
Molded Top Width	E1		9.75 BSC		
Exposed Pad Width	E2		5.90	6.00	6.10
Overall Length	D		10.00 BSC		
Molded Top Length	D1		9.75 BSC		
Exposed Pad Length	D2		5.90	6.00	6.10
Corner Chamfer	P		0.24	0.42	0.60
Terminal Width	b		0.18	0.23	0.30
Terminal Dimple Width	b1		0.10	0.15	0.20
Terminal Length	L		0.30	0.40	0.50
Terminal Dimple Length (side)	L1		0.05	0.15	0.25
Terminal Dimple Length (bottom)	L2		0.05	0.10	0.15
Terminal-to-Exposed-Pad	K		0.20	-	-
Mold Draft Angle	$\theta$		0°	-	12°

**Notes:**

1. Pin 1 visual index feature may vary, but must be located within the hatched area.
2. Package is punch singulated
3. Dimensioning and tolerancing per ASME Y14.5M

BSC: Basic Dimension. Theoretically exact value shown without tolerances.

REF: Reference Dimension, usually without tolerance, for information purposes only.

---



---

## Footprint Outlines and Dimensions

---



---

### 72-Lead Plastic Quad Flat, No Lead Package (6E) - 10x10 mm Body [VQFN] 6.0x6.0 mm Exposed Pad; Punch Singulated, Dimpled Terminals (Also called QFN)

**Note:** For the most current package drawings, please see the Microchip Packaging Specification located at <http://www.microchip.com/packaging>

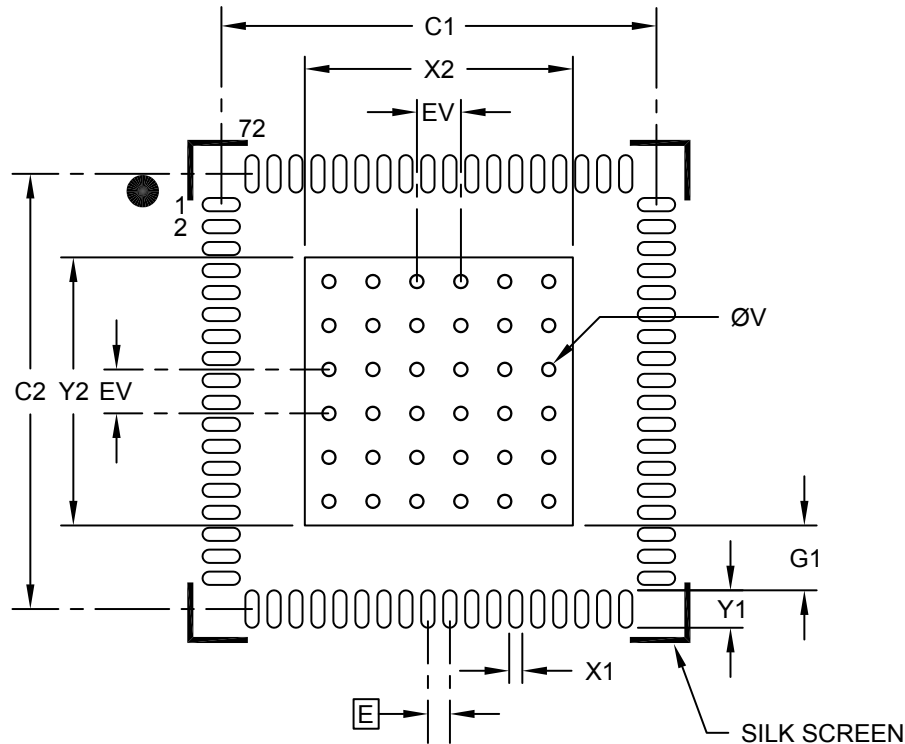

### RECOMMENDED LAND PATTERN

Dimension Limits	Units	MILLIMETERS		
		MIN	NOM	MAX
Contact Pitch	E	0.50 BSC		
Optional Center Pad Width	X2			6.10
Optional Center Pad Length	Y2			6.10
Contact Pad Spacing	C1		9.90	
Contact Pad Spacing	C2		9.90	
Contact Pad Width (X72)	X1			0.30
Contact Pad Length (X72)	Y1			0.85
Contact Pad to Center Pad (X72)	G1	0.20		
Thermal Via Diameter	V		0.30	
Thermal Via Pitch	EV		1.00	

**Notes:**

1. Dimensioning and tolerancing per ASME Y14.5M  
BSC: Basic Dimension. Theoretically exact value shown without tolerances.
2. For best soldering results, thermal vias, if used, should be "filled" or "tented" to avoid solder loss during reflow process

**Package Outlines and Dimensions**

**80-Lead Plastic Quad Flat, No Lead Package (6FX) – 11x11x0.9 mm Body [VQFN]**

**Note:** For the most current package drawings, please see the Microchip Packaging Specification located at <http://www.microchip.com/packaging>

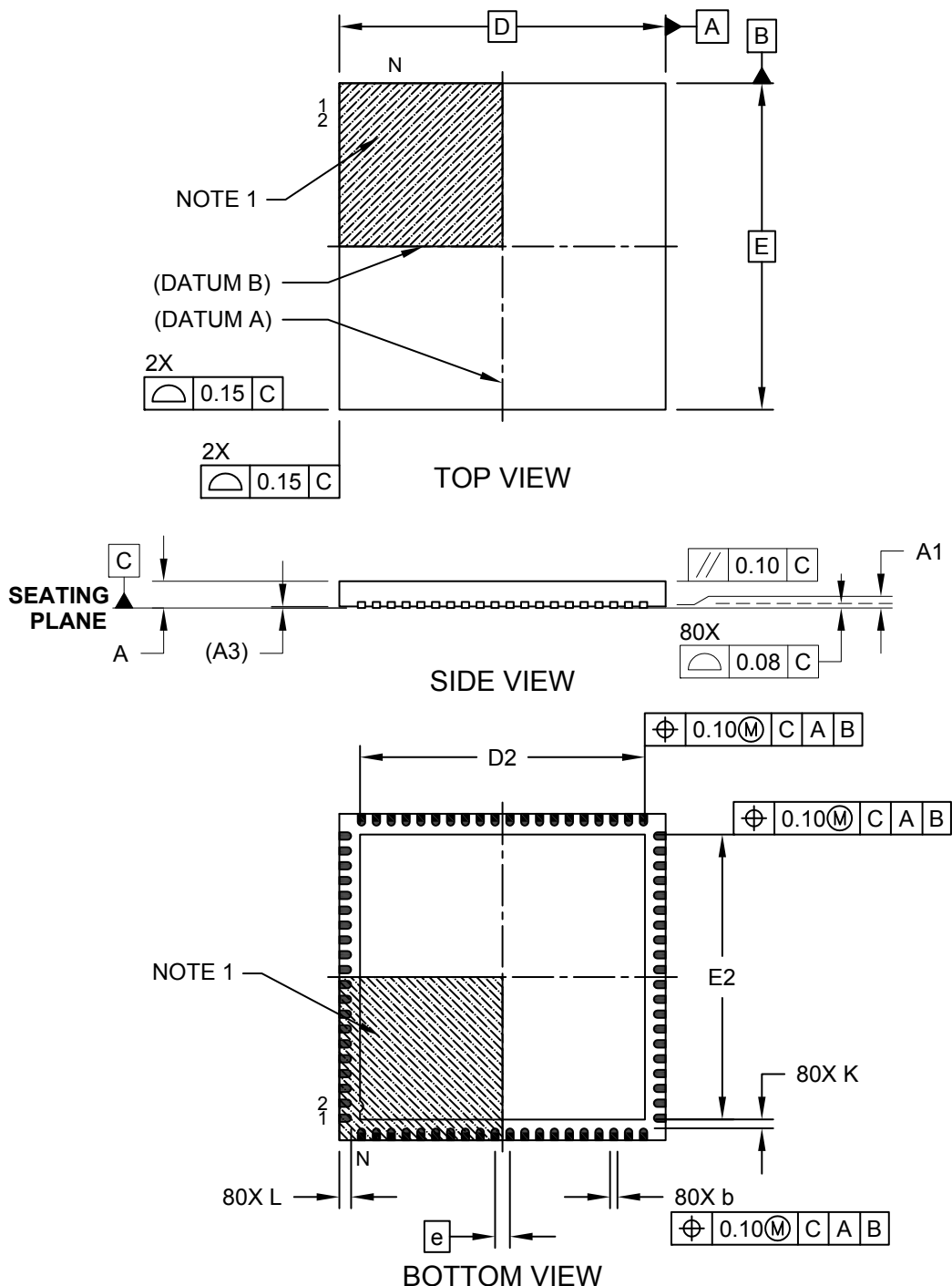

---



---

## Package Outlines and Dimensions

---



---

### 80-Lead Plastic Quad Flat, No Lead Package (6FX) – 11x11x0.9 mm Body [VQFN]

**Note:** For the most current package drawings, please see the Microchip Packaging Specification located at <http://www.microchip.com/packaging>

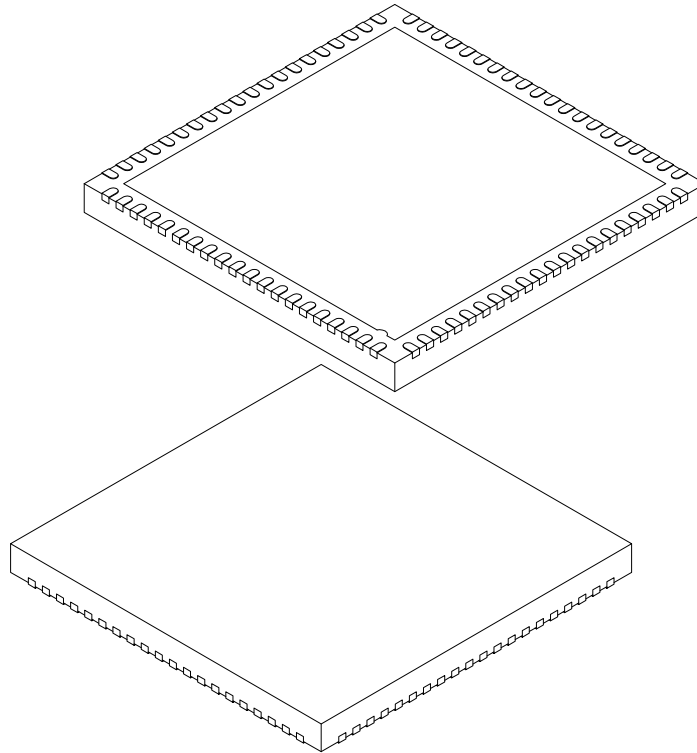

		Units	MILLIMETERS		
		Dimension Limits	MIN	NOM	MAX
Number of Terminals	N	80			
Pitch	e	0.50 BSC			
Overall Height	A	0.80	0.85	0.90	
Standoff	A1	0.00	-	0.05	
Terminal Thickness	(A3)	0.203 REF			
Overall Width	E	11.00 BSC			
Exposed Pad Width	E2	9.50	9.60	9.70	
Overall Length	D	11.00 BSC			
Exposed Pad Length	D2	9.50	9.60	9.70	
Terminal Width	b	0.18	0.25	0.30	
Terminal Length	L	0.30	0.40	0.50	
Terminal-to-Exposed Pad	K	0.20	-	-	

**Notes:**

1. Pin 1 visual index feature may vary, but must be located within the hatched area.
2. Package is saw singulated.
3. Dimensioning and tolerancing per ASME Y14.5M.  
 BSC: Basic Dimension. Theoretically exact value shown without tolerances.  
 REF: Reference Dimension, usually without tolerance, for information purposes only.

**Footprint Outlines and Dimensions**

**80-Lead Plastic Quad Flat, No Lead Package (6FX) – 11x11x0.9 mm Body [VQFN]**

**Note:** For the most current package drawings, please see the Microchip Packaging Specification located at <http://www.microchip.com/packaging>

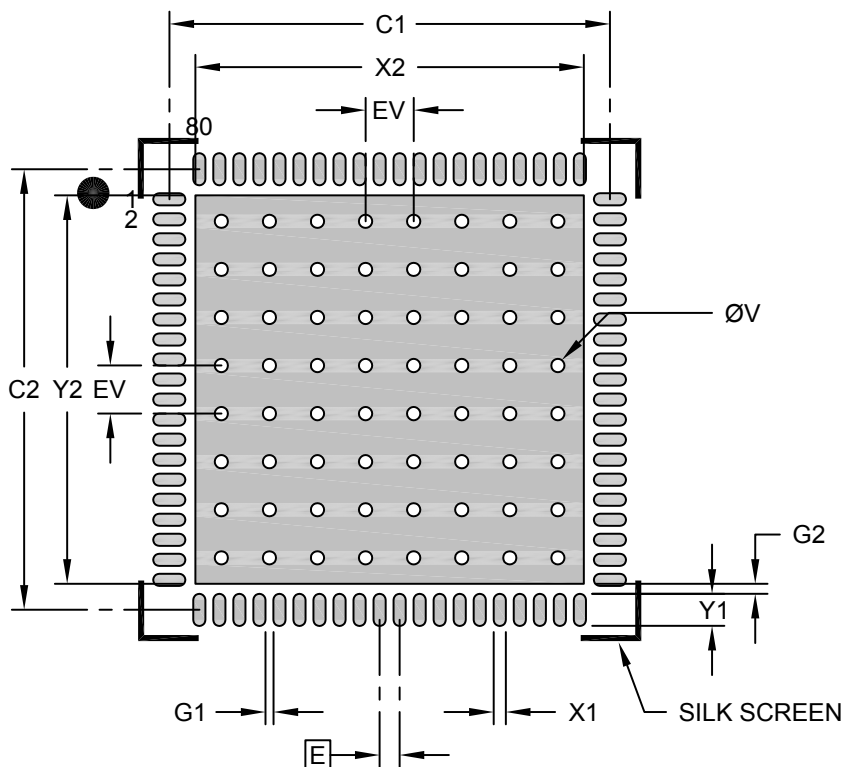

**RECOMMENDED LAND PATTERN**

Dimension Limits	Units	MILLIMETERS		
		MIN	NOM	MAX
Contact Pitch	E	0.50 BSC		
Optional Center Pad Width	X2			9.70
Optional Center Pad Length	Y2			9.70
Contact Pad Spacing	C1		11.00	
Contact Pad Spacing	C2		11.00	
Contact Pad Width (X80)	X1			0.30
Contact Pad Length (X20)	Y1			0.80
Contact Pad to Contact Pad (X76)	G1	0.20		
Contact Pad to Center Pad (X80)	G2	0.20		
Thermal Via Diameter	V		0.33	
Thermal Via Pitch	EV		1.200	

**Notes:**

- Dimensioning and tolerancing per ASME Y14.5M  
BSC: Basic Dimension. Theoretically exact value shown without tolerances.
- For best soldering results, thermal vias, if used, should be filled or tented to avoid solder loss during reflow process



**Package Outlines and Dimensions**

**80-Lead Plastic Quad Flat, No Lead Package (8FX) – 11x11x0.9 mm Body [VQFN]**

**Note:** For the most current package drawings, please see the Microchip Packaging Specification located at <http://www.microchip.com/packaging>

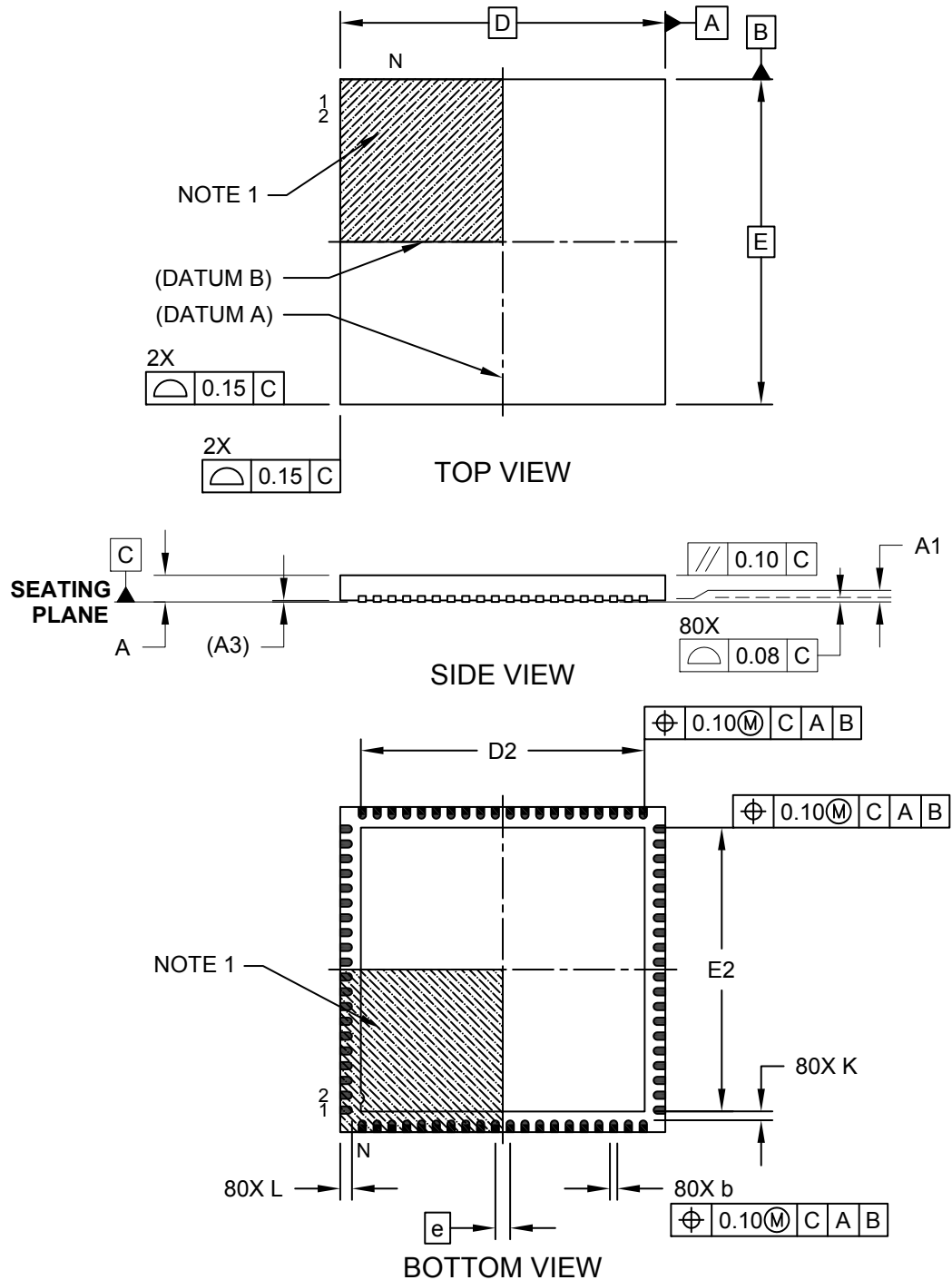

**Package Outlines and Dimensions**

**80-Lead Plastic Quad Flat, No Lead Package (8FX) – 11x11x0.9 mm Body [VQFN]**

**Note:** For the most current package drawings, please see the Microchip Packaging Specification located at <http://www.microchip.com/packaging>

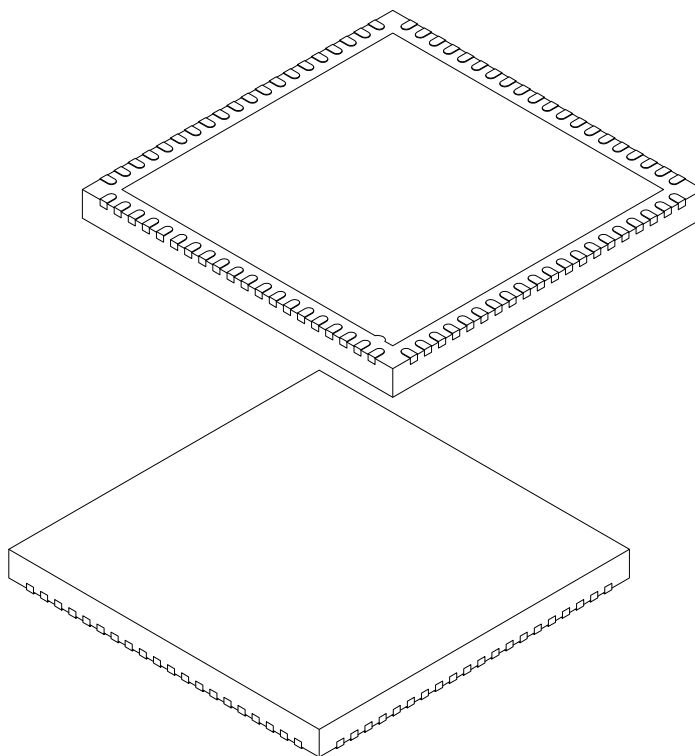

Units		MILLIMETERS		
Dimension Limits		MIN	NOM	MAX
Number of Terminals	N	80		
Pitch	e	0.50 BSC		
Overall Height	A	0.80	0.85	0.90
Standoff	A1	0.00	-	0.05
Terminal Thickness	(A3)	0.203 REF		
Overall Width	E	11.00 BSC		
Exposed Pad Width	E2	9.50	9.60	9.70
Overall Length	D	11.00 BSC		
Exposed Pad Length	D2	9.50	9.60	9.70
Terminal Width	b	0.18	0.25	0.30
Terminal Length	L	0.30	0.40	0.50
Terminal-to-Exposed Pad	K	0.20	-	-

**Notes:**

1. Pin 1 visual index feature may vary, but must be located within the hatched area.
2. Package is saw singulated.
3. Dimensioning and tolerancing per ASME Y14.5M.  
 BSC: Basic Dimension. Theoretically exact value shown without tolerances.  
 REF: Reference Dimension, usually without tolerance, for information purposes only.

---



---

## Footprint Outlines and Dimensions

---



---

### 80-Lead Plastic Quad Flat, No Lead Package (8FX) – 11x11x0.9 mm Body [VQFN]

**Note:** For the most current package drawings, please see the Microchip Packaging Specification located at <http://www.microchip.com/packaging>

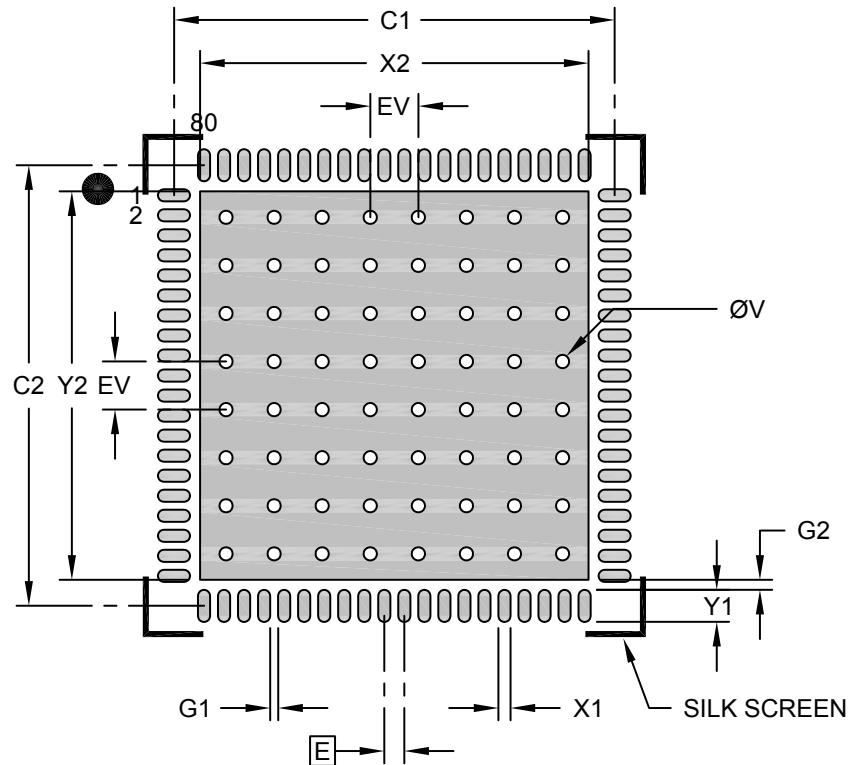

#### RECOMMENDED LAND PATTERN

Dimension Limits	Units	MILLIMETERS		
		MIN	NOM	MAX
Contact Pitch	E	0.50 BSC		
Optional Center Pad Width	X2			9.70
Optional Center Pad Length	Y2			9.70
Contact Pad Spacing	C1		11.00	
Contact Pad Spacing	C2		11.00	
Contact Pad Width (X80)	X1			0.30
Contact Pad Length (X20)	Y1			0.80
Contact Pad to Contact Pad (X76)	G1	0.20		
Contact Pad to Center Pad (X80)	G2	0.20		
Thermal Via Diameter	V		0.33	
Thermal Via Pitch	EV		1.200	

**Notes:**

1. Dimensioning and tolerancing per ASME Y14.5M  
     BSC: Basic Dimension. Theoretically exact value shown without tolerances.
2. For best soldering results, thermal vias, if used, should be filled or tented to avoid solder loss during reflow process



**MICROCHIP**

---

---

**Package Outlines and Dimensions**

---

---

NOTES:

---

---

**Package Outlines and Dimensions**

---

---

**QFN-S**

**Package Outlines and Dimensions**

**28-Lead Plastic Quad Flat, No Lead Package (MM) - 6x6x0.9mm Body [QFN-S]  
With 0.40 mm Terminal Length**

**Note:** For the most current package drawings, please see the Microchip Packaging Specification located at <http://www.microchip.com/packaging>

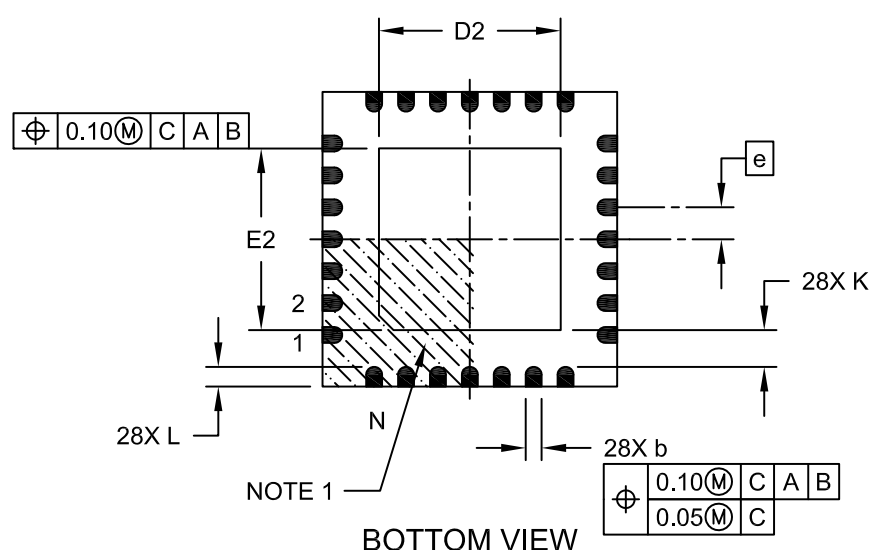
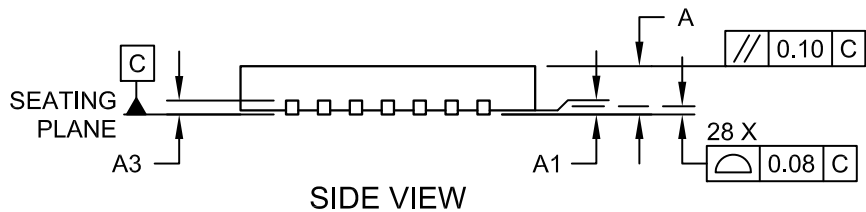
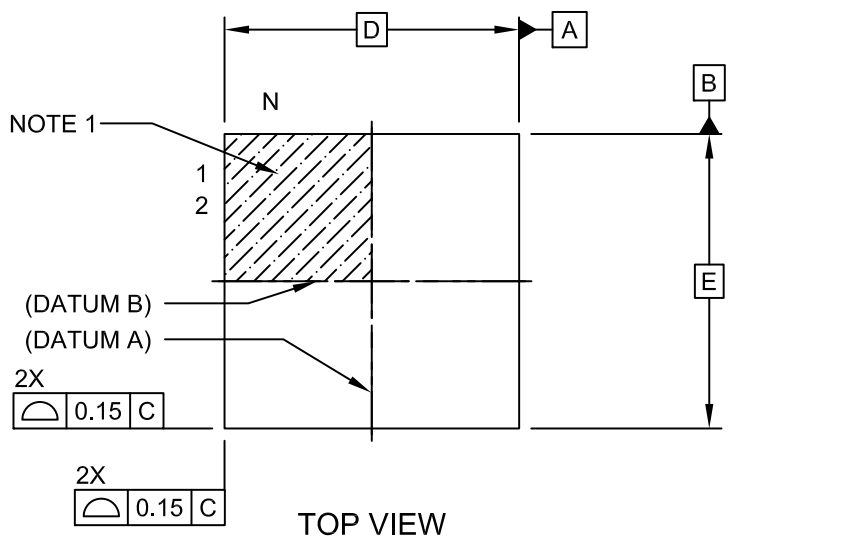

---



---

## Package Outlines and Dimensions

---



---

### 28-Lead Plastic Quad Flat, No Lead Package (MM) - 6x6x0.9mm Body [QFN-S] With 0.40 mm Terminal Length

**Note:** For the most current package drawings, please see the Microchip Packaging Specification located at <http://www.microchip.com/packaging>

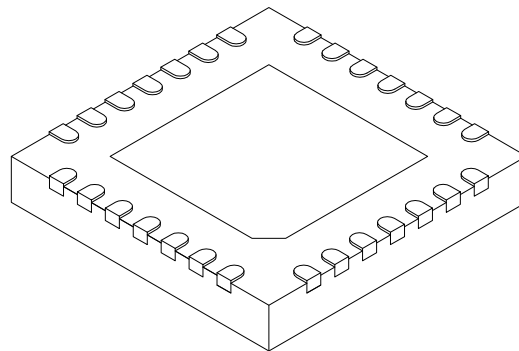

Dimension Limits	Units	MILLIMETERS		
		MIN	NOM	MAX
Number of Pins	N	28		
Pitch	e	0.65 BSC		
Overall Height	A	0.80	0.90	1.00
Standoff	A1	0.00	0.02	0.05
Terminal Thickness	A3	0.20 REF		
Overall Width	E	6.00 BSC		
Exposed Pad Width	E2	3.65	3.70	4.70
Overall Length	D	6.00 BSC		
Exposed Pad Length	D2	3.65	3.70	4.70
Terminal Width	b	0.23	0.30	0.35
Terminal Length	L	0.30	0.40	0.50
Terminal-to-Exposed Pad	K	0.20	-	-

**Notes:**

1. Pin 1 visual index feature may vary, but must be located within the hatched area.
2. Package is saw singulated
3. Dimensioning and tolerancing per ASME Y14.5M

BSC: Basic Dimension. Theoretically exact value shown without tolerances.

REF: Reference Dimension, usually without tolerance, for information purposes only.

**Footprint Outlines and Dimensions**

**28-Lead Plastic Quad Flat, No Lead Package (MM) – 6x6x0.9 mm Body [QFN-S]  
with 0.40 mm Contact Length**

**Note:** For the most current package drawings, please see the Microchip Packaging Specification located at <http://www.microchip.com/packaging>

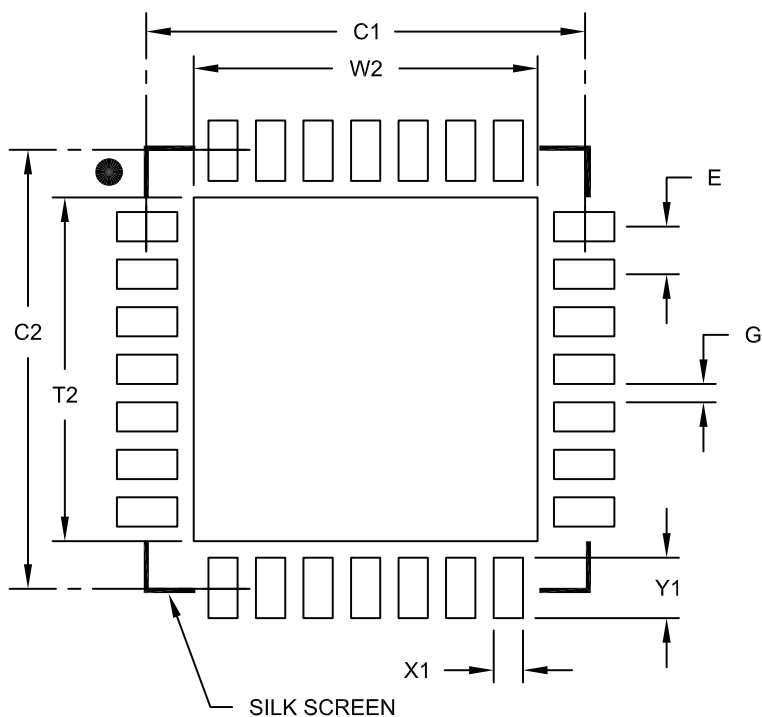

**RECOMMENDED LAND PATTERN**

Dimension Limits	Units	MILLIMETERS		
		MIN	NOM	MAX
Contact Pitch	E	0.65 BSC		
Optional Center Pad Width	W2			4.70
Optional Center Pad Length	T2			4.70
Contact Pad Spacing	C1		6.00	
Contact Pad Spacing	C2		6.00	
Contact Pad Width (X28)	X1			0.40
Contact Pad Length (X28)	Y1			0.85
Distance Between Pads	G	0.25		

Notes:

1. Dimensioning and tolerancing per ASME Y14.5M

BSC: Basic Dimension. Theoretically exact value shown without tolerances.

Microchip Technology Drawing No. C04-2124A



---

---

**Package Outlines and Dimensions**

---

---

**MQFN**

**Package Outlines and Dimensions**

**20-Lead More Thin Plastic Quad Flat, No Lead Package (NU) - 5x5x1.0 mm Body [MQFN] - (Also called VQFN)**

**Note:** For the most current package drawings, please see the Microchip Packaging Specification located at <http://www.microchip.com/packaging>

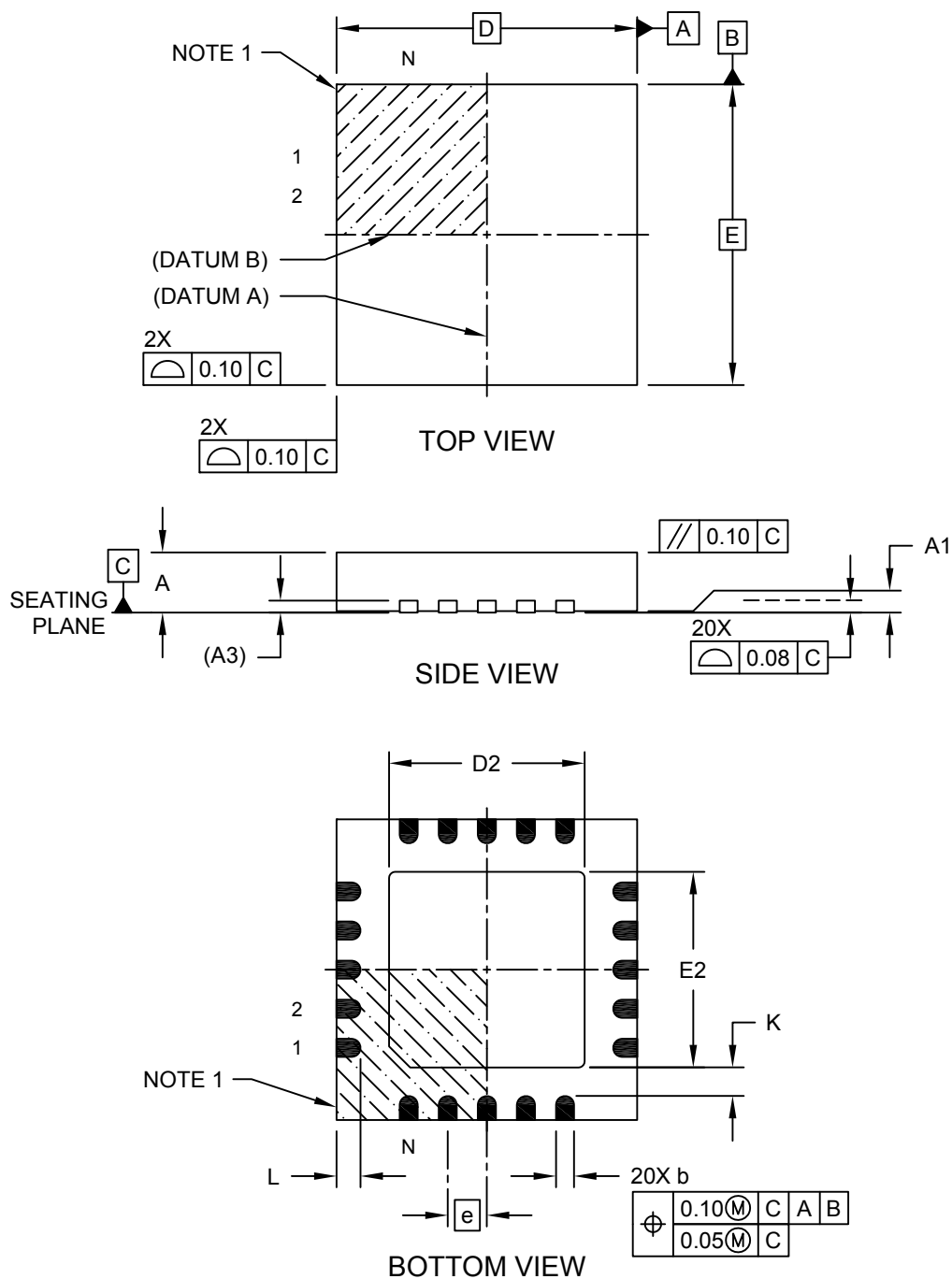

---



---

## Package Outlines and Dimensions

---



---

### 20-Lead More Thin Plastic Quad Flat, No Lead Package (NU) - 5x5x1.0 mm Body [MQFN] - (Also called VQFN)

**Note:** For the most current package drawings, please see the Microchip Packaging Specification located at <http://www.microchip.com/packaging>

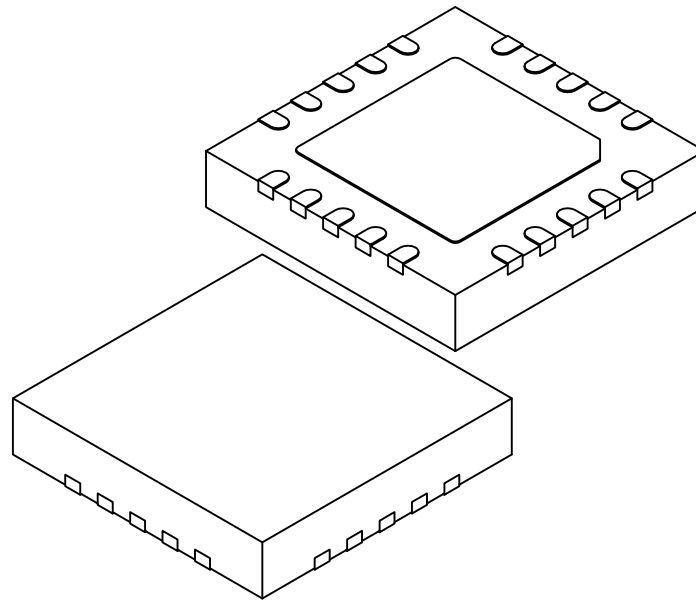

Dimension Limits	Units	MILLIMETERS		
		MIN	NOM	MAX
Number of Pins	N	20		
Pitch	e	0.65 BSC		
Overall Height	A	0.90	0.95	1.00
Standoff	A1	0.00	0.02	0.05
Terminal Thickness	A3	0.20 REF		
Overall Length	D	5.00 BSC		
Exposed Pad Length	D2	3.15	3.25	3.35
Overall Width	E	5.00 BSC		
Exposed Pad Width	E2	3.15	3.25	3.35
Terminal Width	b	0.25	0.30	0.35
Terminal Length	L	0.35	0.40	0.45
Terminal-to-Exposed-Pad	K	0.20	-	-

**Notes:**

1. Pin 1 visual index feature may vary, but must be located within the hatched area.
2. Package is saw singulated
3. Dimensioning and tolerancing per ASME Y14.5M

BSC: Basic Dimension. Theoretically exact value shown without tolerances.

REF: Reference Dimension, usually without tolerance, for information purposes only.

**Footprint Outlines and Dimensions**

**20-Lead More Thin Plastic Quad Flat, No Lead Package (NU) - 5x5x1.0 mm Body [MQFN] - (Also called VQFN)**

**Note:** For the most current package drawings, please see the Microchip Packaging Specification located at <http://www.microchip.com/packaging>

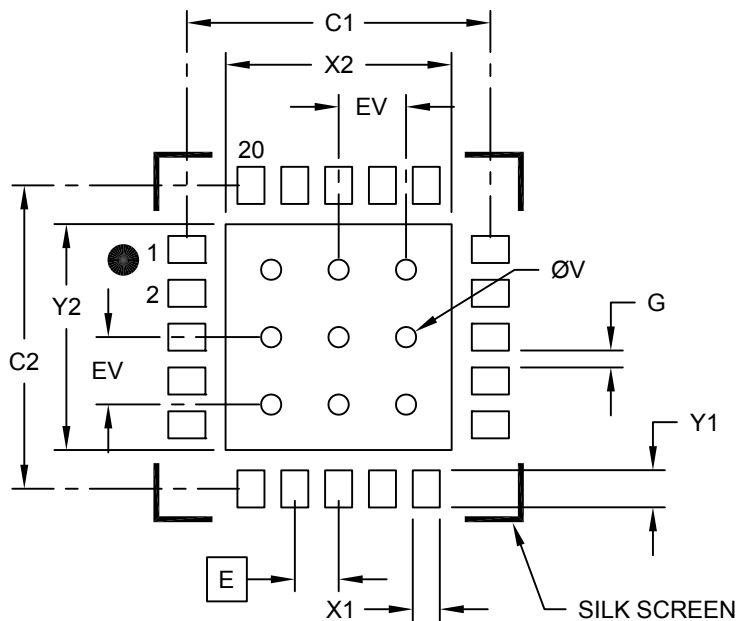

**RECOMMENDED LAND PATTERN**

Dimension Limits	Units	MILLIMETERS		
		MIN	NOM	MAX
Contact Pitch	E	0.65 BSC		
Optional Center Pad Width	W2			3.35
Optional Center Pad Length	T2			3.35
Contact Pad Spacing	C1		4.50	
Contact Pad Spacing	C2		4.50	
Contact Pad Width (X20)	X1			0.40
Contact Pad Length (X20)	Y1			0.55
Distance Between Pads	G	0.20		
Thermal Via Diameter	V		0.30	
Thermal Via Pitch	EV		1.00	

**Notes:**

1. Dimensioning and tolerancing per ASME Y14.5M  
BSC: Basic Dimension. Theoretically exact value shown without tolerances.
2. For best soldering results, thermal vias, if used, should be filled or tented to avoid solder loss during reflow process

---

---

**Package Outlines and Dimensions**

---

---

**UQFN**

**Package Outlines and Dimensions**

**4-Lead Plastic Ultra Thin Quad Flatpack No-Leads (5X) - 1x1x0.6mm [UQFN]  
(Formerly USPQ-4B04)**

**Note:** For the most current package drawings, please see the Microchip Packaging Specification located at <http://www.microchip.com/packaging>

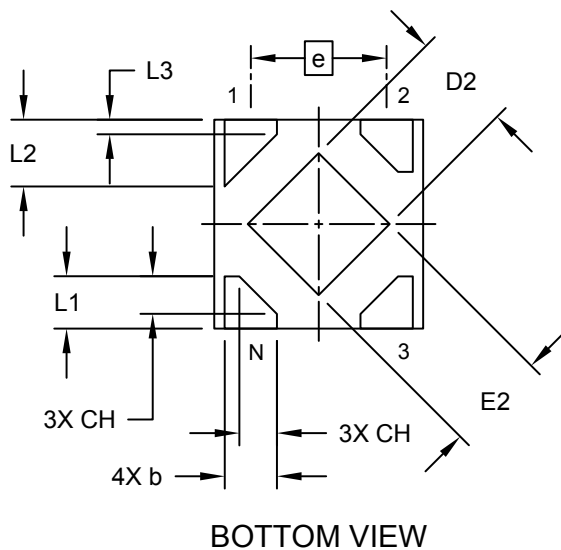
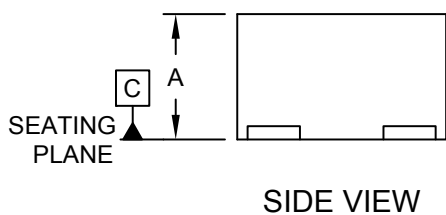
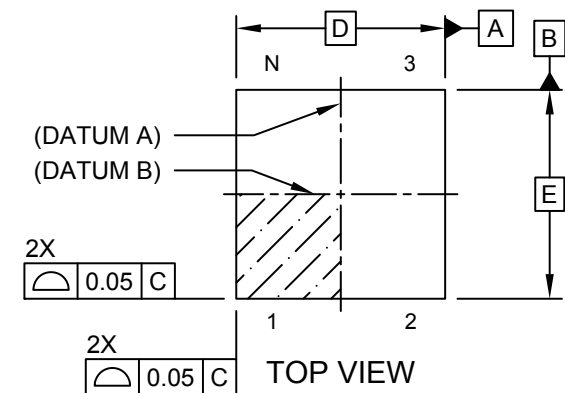

---



---

## Package Outlines and Dimensions

---



---

### 4-Lead Plastic Ultra Thin Quad Flatpack No-Leads (5X) - 1x1x0.6mm [UQFN] (Formerly USPQ-4B04)

**Note:** For the most current package drawings, please see the Microchip Packaging Specification located at <http://www.microchip.com/packaging>

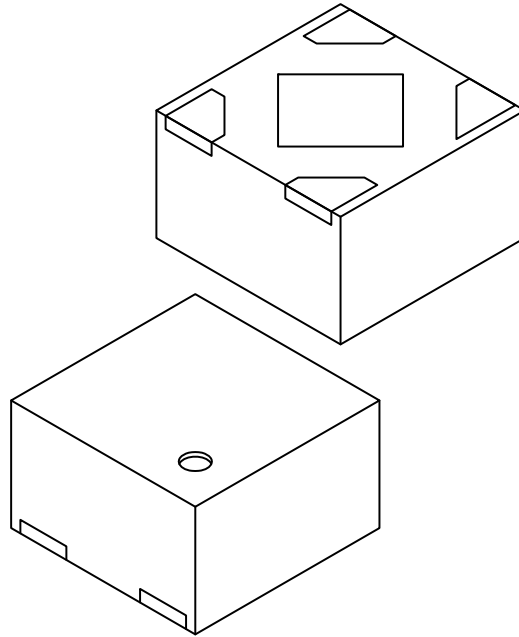

		Units	MILLIMETERS		
Dimension Limits			MIN	NOM	MAX
Number of Terminals	N		4		
Pitch	e		0.65 BSC		
Overall Height	A	-	-	-	0.60
Overall Width	E		1.00 BSC		
Exposed Pad Width	E2	0.43	0.48		0.53
Overall Length	D		1.00 BSC		
Exposed Pad Length	D2	0.43	0.48		0.53
Terminal Width	b	0.20	0.25		0.30
Terminal Length	L1	0.20	0.25		0.30
Terminal Length	L2	0.27	0.32		0.37
-	L3	0.02	0.07		0.12
Terminal Chamfer	CH	-	0.18		-

**Notes:**

1. Pin 1 visual index feature may vary, but must be located within the hatched area.
2. Package is saw singulated
3. Dimensioning and tolerancing per ASME Y14.5M

BSC: Basic Dimension. Theoretically exact value shown without tolerances.

REF: Reference Dimension, usually without tolerance, for information purposes only.

**Footprint Outlines and Dimensions**

**4-Lead Plastic Ultra Thin Quad Flatpack No-Leads (5X) - 1x1x0.6mm [UQFN]  
(Formerly USPQ-4B04)**

**Note:** For the most current package drawings, please see the Microchip Packaging Specification located at <http://www.microchip.com/packaging>

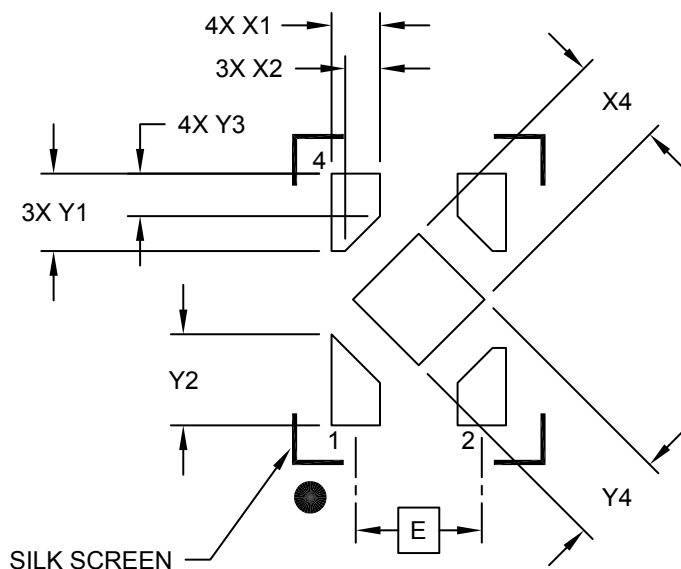

**RECOMMENDED LAND PATTERN**

Units	MILLIMETERS		
	MIN	NOM	MAX
E	0.65 BSC		
X1		0.25	
X2		0.18	
X4		0.48	
Y1		0.40	
Y2		0.47	
Y3		0.22	
Y4		0.48	

**Notes:**

- Dimensioning and tolerancing per ASME Y14.5M  
BSC: Basic Dimension. Theoretically exact value shown without tolerances.



**Package Outlines and Dimensions**

**10-Lead Ultra Thin Plastic Quad Flat, No Lead Package (2V) - 1.3x1.8x0.6 mm Body [UQFN] Chip-On-Lead**

**Note:** For the most current package drawings, please see the Microchip Packaging Specification located at <http://www.microchip.com/packaging>

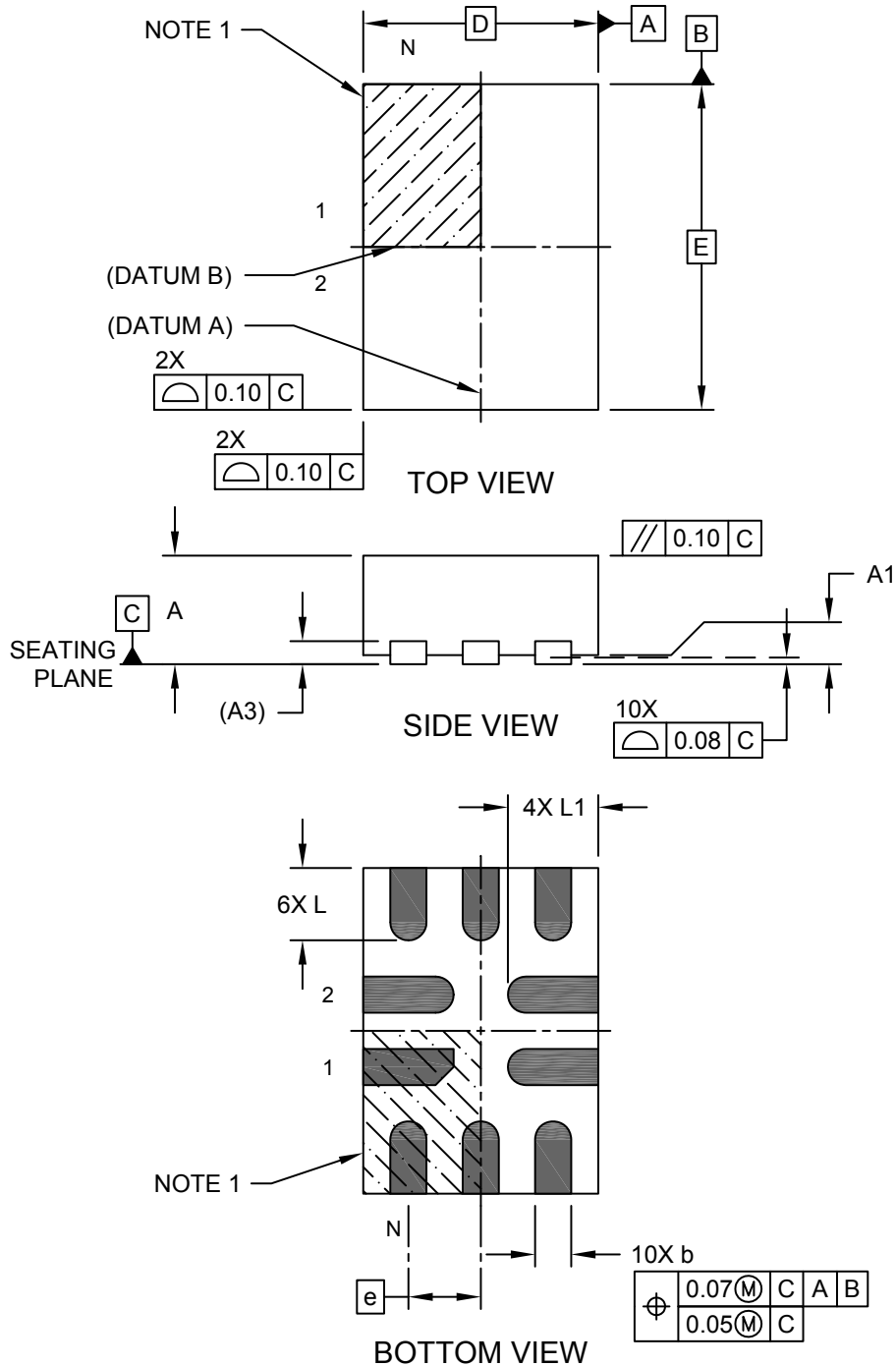

**Package Outlines and Dimensions**

**10-Lead Ultra Thin Plastic Quad Flat, No Lead Package (2V) - 1.3x1.8x0.6 mm Body [UQFN] Chip-On-Lead**

**Note:** For the most current package drawings, please see the Microchip Packaging Specification located at <http://www.microchip.com/packaging>

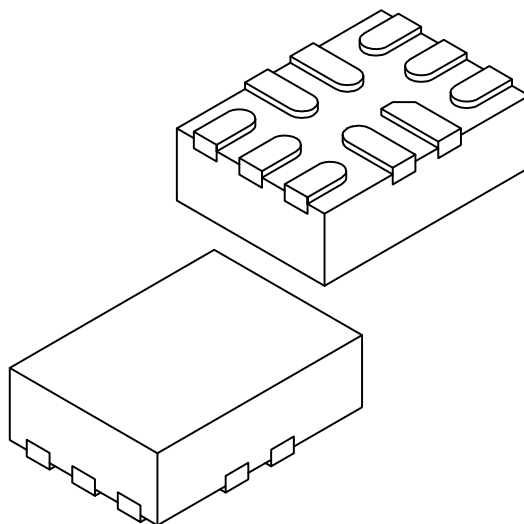

		Units	MILLIMETERS		
Dimension Limits			MIN	NOM	MAX
Number of Terminals	N		10		
Pitch	e		0.40 BSC		
Overall Height	A	0.50	0.55	0.60	
Standoff	A1	0.00	0.02	0.05	
Terminal Thickness	A3	0.127 REF			
Overall Length	D	1.30 BSC			
Overall Width	E	1.80 BSC			
Terminal Width	b	0.15	0.20	0.25	
Terminal Length	L	0.35	0.40	0.45	
Terminal Length	L1	0.45	0.50	0.55	

**Notes:**

- Pin 1 visual index feature may vary, but must be located within the hatched area.
- Package is saw singulated
- Dimensioning and tolerancing per ASME Y14.5M

BSC: Basic Dimension. Theoretically exact value shown without tolerances.

REF: Reference Dimension, usually without tolerance, for information purposes only.

---



---

## Footprint Outlines and Dimensions

---



---

### 10-Lead Ultra Thin Plastic Quad Flat, No Lead Package (2V) - 1.3x1.8x0.6 mm Body [UQFN] Chip-On-Lead

**Note:** For the most current package drawings, please see the Microchip Packaging Specification located at <http://www.microchip.com/packaging>

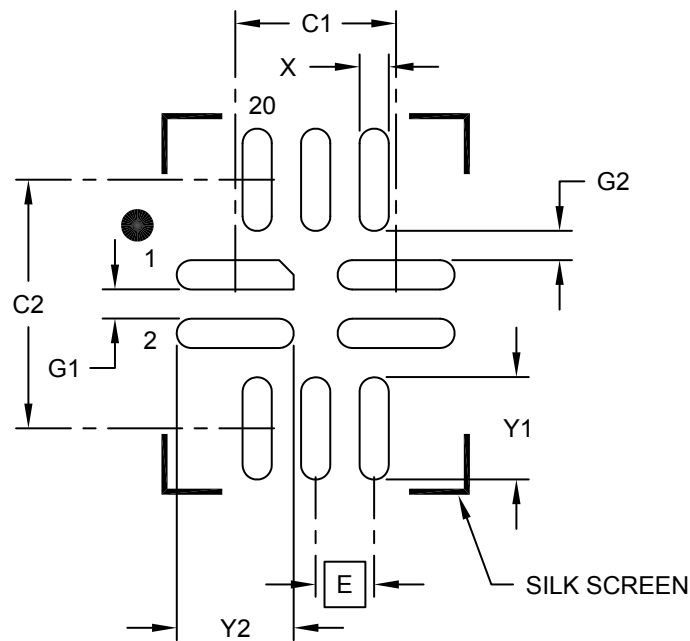

### RECOMMENDED LAND PATTERN

Dimension Limits	Units	MILLIMETERS		
		MIN	NOM	MAX
Contact Pitch	E	0.40 BSC		
Contact Pad Spacing	C1		1.10	
Contact Pad Spacing	C2		1.70	
Contact Pad Width (X10)	X			0.20
Contact Pad Length (X6)	Y1			0.70
Contact Pad Length (X4)	Y2			0.80
Contact Pad to Pad (X6)	G1	0.20		
Contact Pad to Pad (X4)	G2	0.20		

**Notes:**

- Dimensioning and tolerancing per ASME Y14.5M  
BSC: Basic Dimension. Theoretically exact value shown without tolerances.

**Package Outlines and Dimensions**

**10-Lead Ultra Thin Plastic Quad Flat, No Lead Package (3V) - 1.6x2.1 mm Body [UQFN] Chip-On-Lead**

**Note:** For the most current package drawings, please see the Microchip Packaging Specification located at <http://www.microchip.com/packaging>

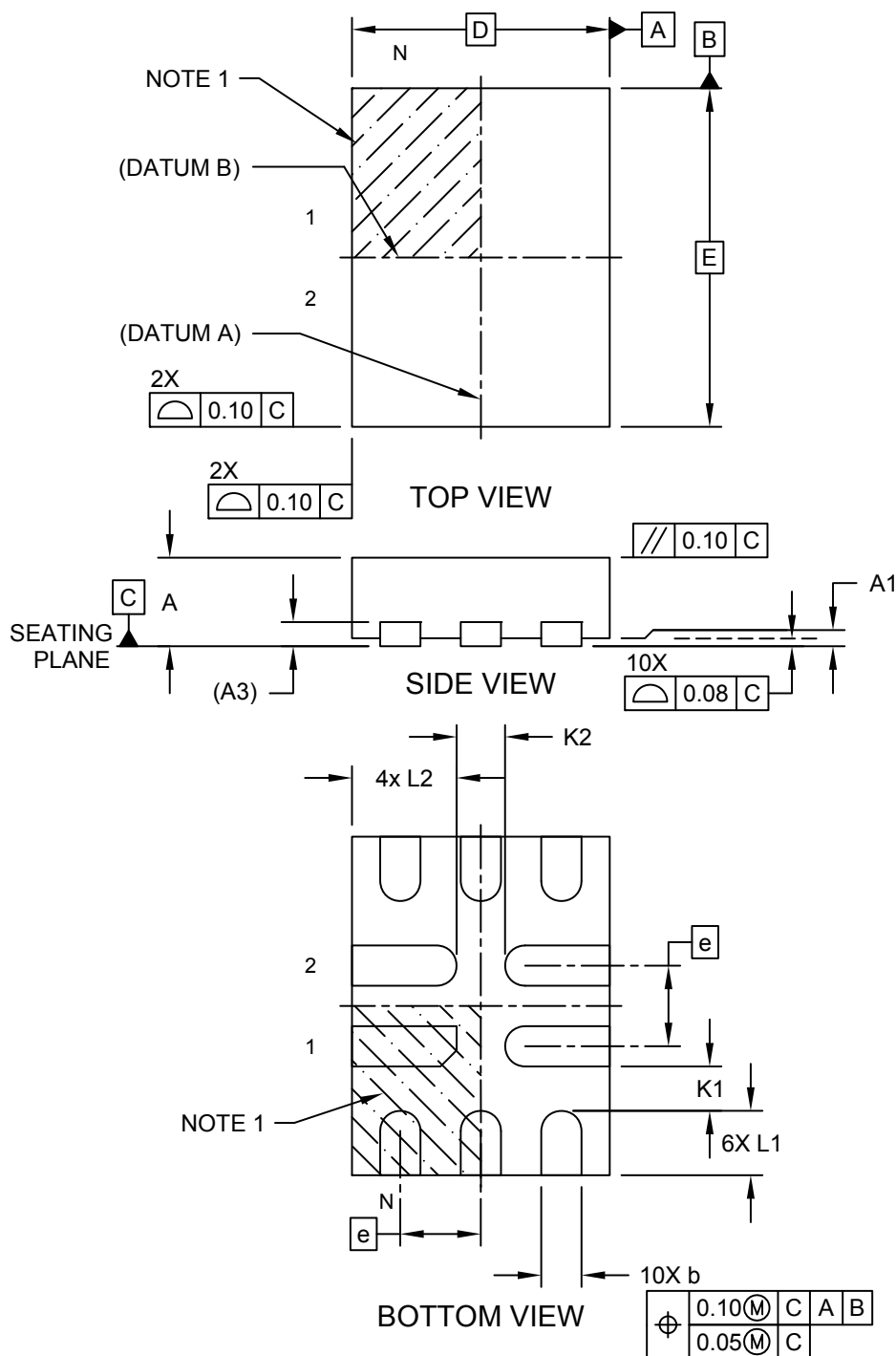

---



---

## Package Outlines and Dimensions

---



---

### 10-Lead Ultra Thin Plastic Quad Flat, No Lead Package (3V) - 1.6x2.1 mm Body [UQFN] Chip-On-Lead

**Note:** For the most current package drawings, please see the Microchip Packaging Specification located at <http://www.microchip.com/packaging>

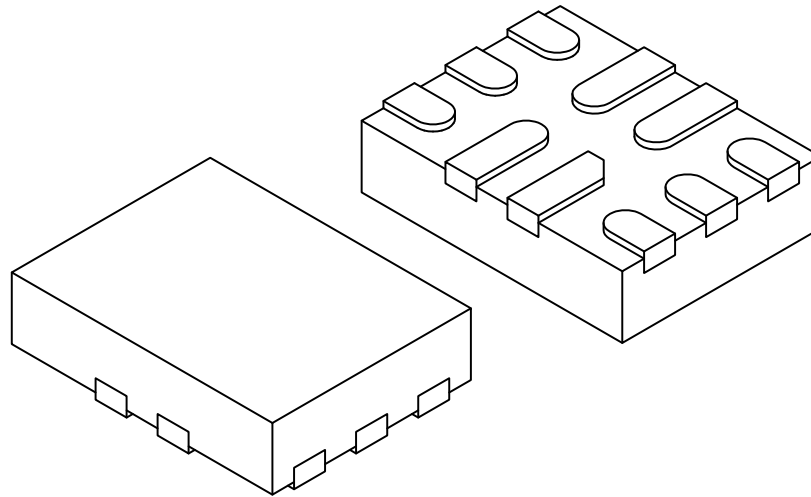

		MILLIMETERS		
Units				
Dimension Limits		MIN	NOM	MAX
Number of Terminals	N	10		
Pitch	e	0.50 BSC		
Overall Height	A	0.50	0.55	0.60
Standoff	A1	0.00	0.02	0.05
Terminal Thickness	(A3)	0.127 REF		
Overall Width	E	2.10 BSC		
Overall Length	D	1.60 BSC		
Terminal Width	b	0.20	0.25	0.30
Terminal Length	L1	0.35	0.40	0.45
Terminal Length	L2	0.60	0.65	0.70
Terminal Clearance	K1	0.20	-	-
Terminal Clearance	K2	0.20	-	-

**Notes:**

1. Pin 1 visual index feature may vary, but must be located within the hatched area.
2. Package is saw singulated
3. Dimensioning and tolerancing per ASME Y14.5M

BSC: Basic Dimension. Theoretically exact value shown without tolerances.

REF: Reference Dimension, usually without tolerance, for information purposes only.

**Footprint Outlines and Dimensions**

**10-Lead Ultra Thin Plastic Quad Flat, No Lead Package (3V) - 1.6x2.1 mm Body [UQFN] Chip-On-Lead**

**Note:** For the most current package drawings, please see the Microchip Packaging Specification located at <http://www.microchip.com/packaging>

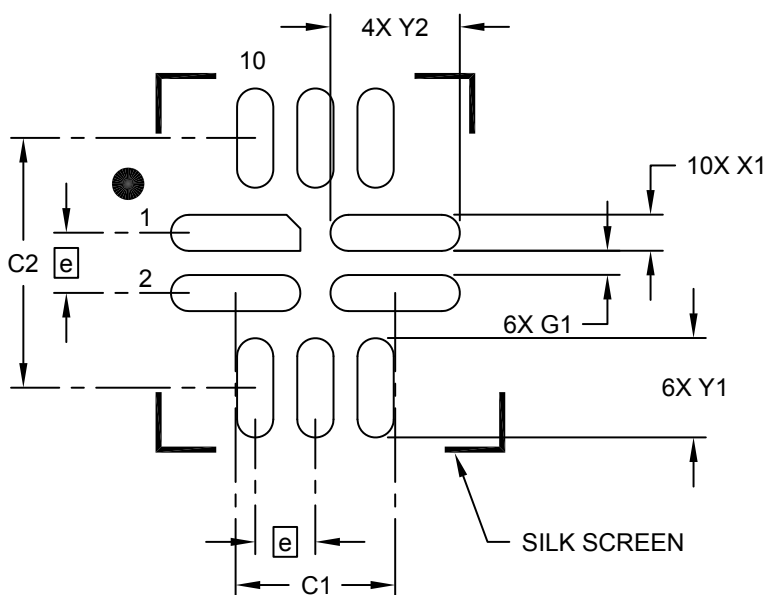

**RECOMMENDED LAND PATTERN**

Dimension Limits	Units	MILLIMETERS		
		MIN	NOM	MAX
Contact Pitch	E	0.50 BSC		
Contact Pad Spacing	C1		1.325	
Contact Pad Spacing	C2		2.075	
Contact Pad Width (X10)	X1			0.30
Contact Pad Length (X6)	Y1			0.825
Contact Pad Length (X4)	Y2			1.075
Contact Pad to Center Pad (X6)	G1	0.20		

Notes:

1. Dimensioning and tolerancing per ASME Y14.5M

BSC: Basic Dimension. Theoretically exact value shown without tolerances.

**Package Outlines and Dimensions**

**12-Lead Ultra Thin Plastic Quad Flat, No Lead Package (QM) - 2x2 mm Body [UQFN]  
(Formerly QUBE/F; SST Legacy Package)**

**Note:** For the most current package drawings, please see the Microchip Packaging Specification located at <http://www.microchip.com/packaging>

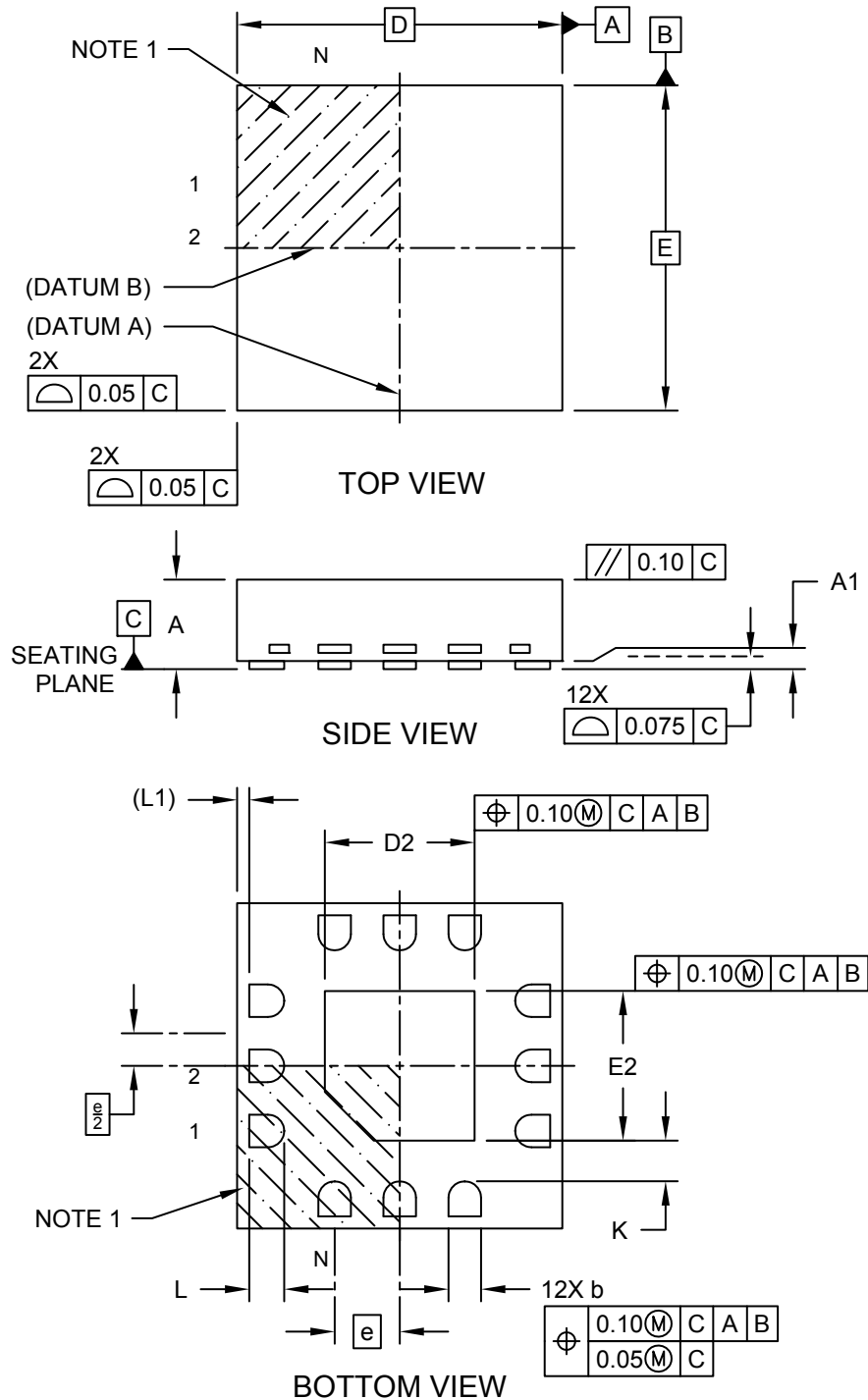

Microchip Technology Drawing C04-247A Sheet 1 of 2

**Package Outlines and Dimensions**

**12-Lead Ultra Thin Plastic Quad Flat, No Lead Package (QM) - 2x2 mm Body [UQFN]  
(Formerly QUBE/F; SST Legacy Package)**

**Note:** For the most current package drawings, please see the Microchip Packaging Specification located at <http://www.microchip.com/packaging>

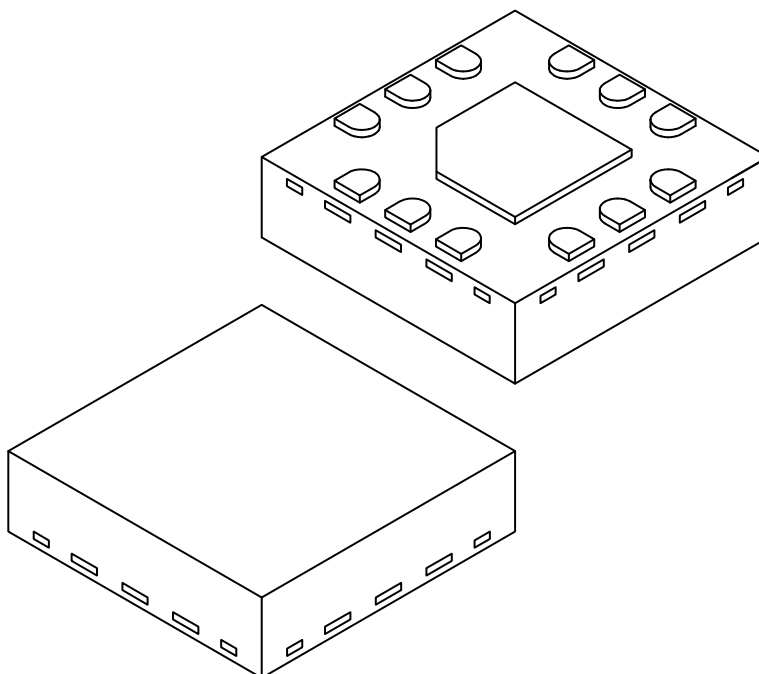

Dimension Limits	Units	MILLIMETERS		
		MIN	NOM	MAX
Number of Terminals	N	12		
Pitch	e	0.40 BSC		
Overall Height	A	0.50	0.55	0.60
Standoff	A1	0.00	0.02	0.05
Overall Length	D	2.00 BSC		
Exposed Pad Length	D2	0.82	0.92	1.02
Overall Width	E	2.00 BSC		
Exposed Pad Width	E2	0.82	0.92	1.02
Terminal Width	b	0.15	0.20	0.25
Terminal Length	L	0.165	0.215	0.265
Pull Back Length	L1	0.075 REF		
Terminal-to-Exposed-Pad	K	0.20	-	-

**Notes:**

1. Pin 1 visual index feature may vary, but must be located within the hatched area.
2. Package is saw singulated
3. Dimensioning and tolerancing per ASME Y14.5M

BSC: Basic Dimension. Theoretically exact value shown without tolerances.

REF: Reference Dimension, usually without tolerance, for information purposes only.



---



---

## Footprint Outlines and Dimensions

---



---

### 12-Lead Ultra Thin Plastic Quad Flat, No Lead Package (QM) - 2x2 mm Body [UQFN] (Formerly QUBE/F; SST Legacy Package)

**Note:** For the most current package drawings, please see the Microchip Packaging Specification located at <http://www.microchip.com/packaging>

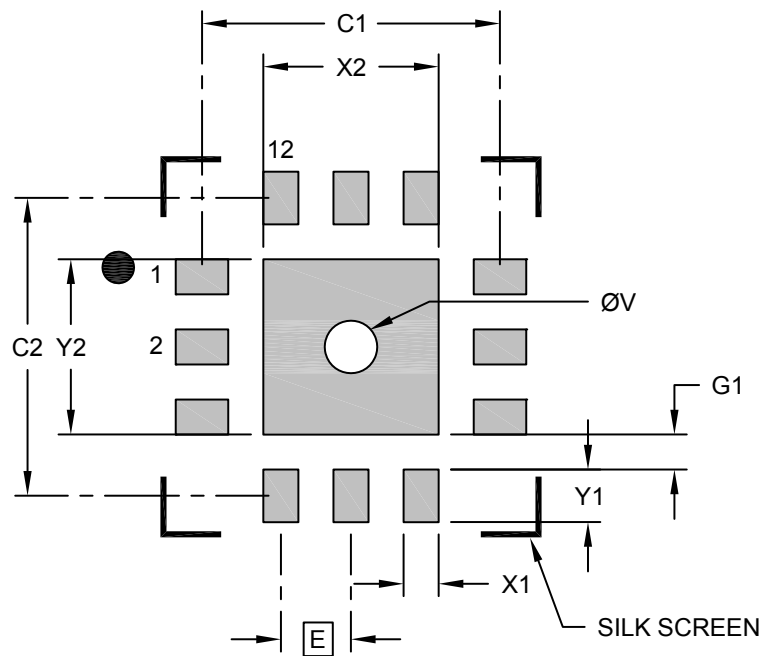

### RECOMMENDED LAND PATTERN

Dimension Limits	Units	MILLIMETERS		
		MIN	NOM	MAX
Contact Pitch	E	0.40 BSC		
Optional Center Pad Width	X2			1.00
Optional Center Pad Length	Y2			1.00
Contact Pad Spacing	C1		1.70	
Contact Pad Spacing	C2		1.70	
Contact Pad Width (X12)	X1			0.20
Contact Pad Length (X12)	Y1			0.30
Contact Pad to Center Pad (X12)	G1	0.20		
Thermal Via Diameter	V		0.33	

**Notes:**

1. Dimensioning and tolerancing per ASME Y14.5M  
     BSC: Basic Dimension. Theoretically exact value shown without tolerances.
2. For best soldering results, thermal vias, if used, should be filled or tented to avoid solder loss during reflow process

**Package Outlines and Dimensions**

**16-Lead Plastic Ultra Thin Quad Flat, No Lead Package (MV) - 2.5x2.5x0.6mm Body [UQFN]**

**Note:** For the most current package drawings, please see the Microchip Packaging Specification located at <http://www.microchip.com/packaging>

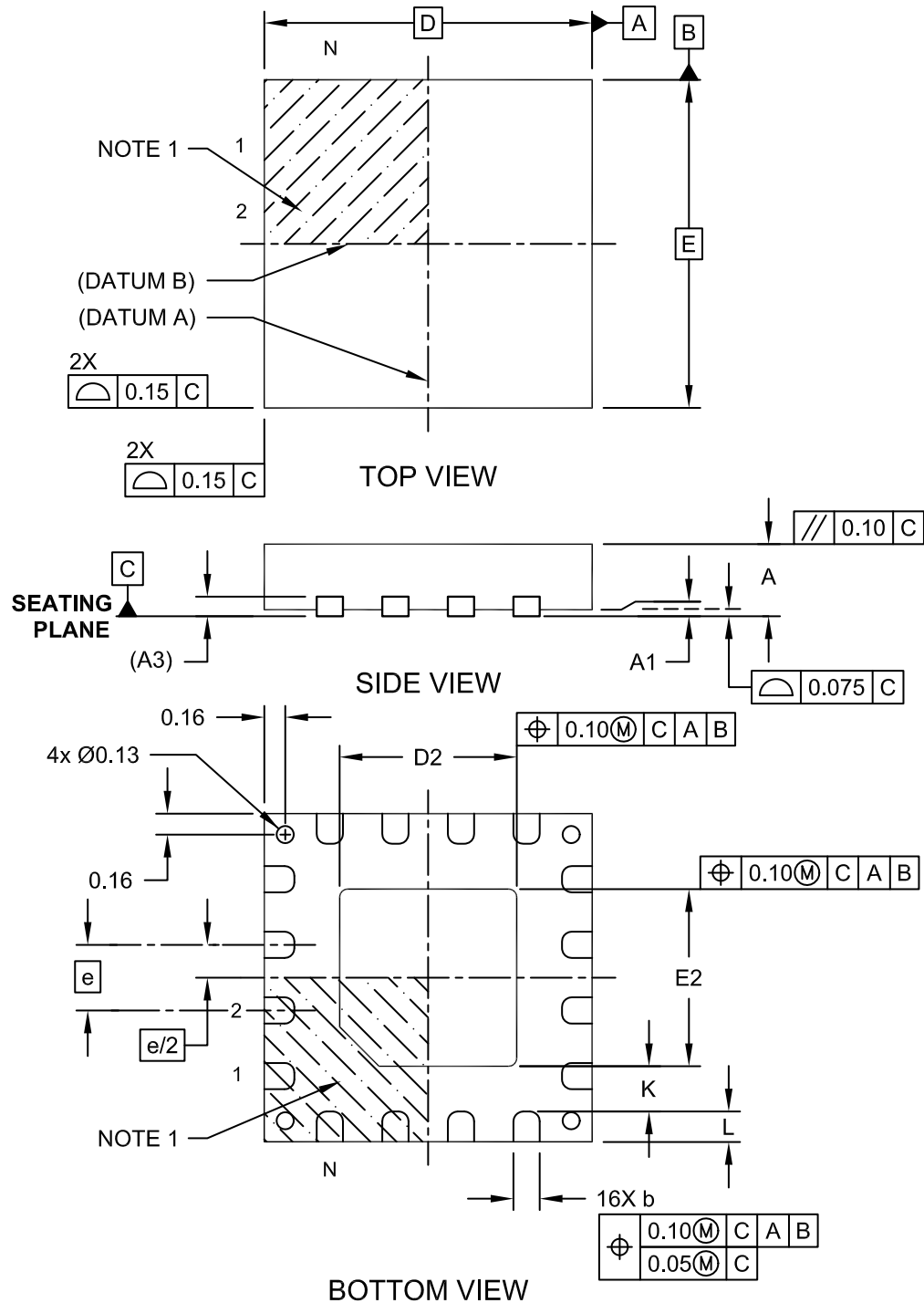

---



---

## Package Outlines and Dimensions

---



---

### 16-Lead Plastic Ultra Thin Quad Flat, No Lead Package (MV) - 2.5x2.5x0.6mm Body [UQFN]

**Note:** For the most current package drawings, please see the Microchip Packaging Specification located at <http://www.microchip.com/packaging>

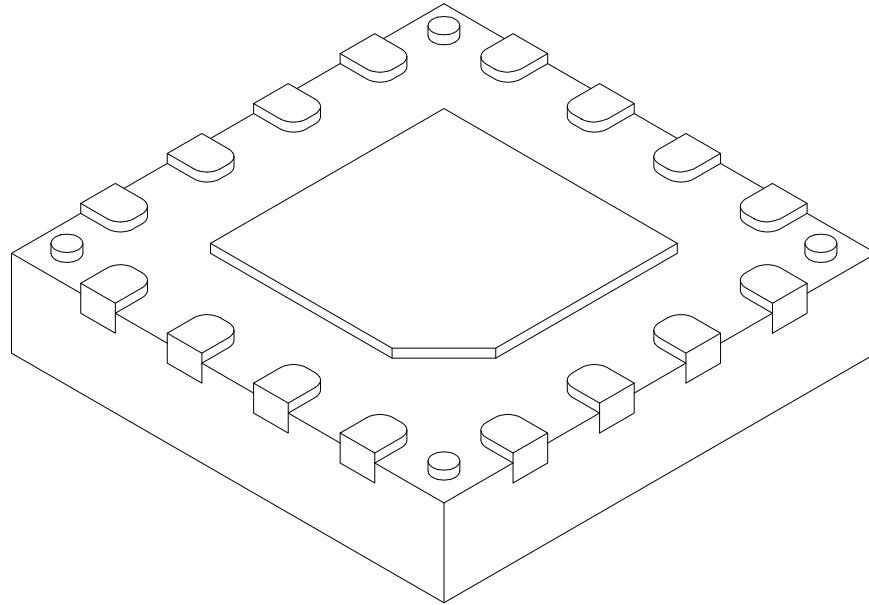

		Units	MILLIMETERS		
Dimension Limits			MIN	NOM	MAX
Number of Terminals	N		16		
Pitch	e		0.50 BSC		
Overall Height	A	0.50	0.55	0.60	
Standoff	A1	0.00	0.02	0.05	
Terminal Thickness	A3		0.15 REF		
Overall Width	E		2.50 BSC		
Exposed Pad Width	E2	1.30	1.35	1.40	
Overall Length	D		2.50 BSC		
Exposed Pad Length	D2	1.30	1.35	1.40	
Terminal Width	b	0.15	0.20	0.25	
Terminal Length	L	0.175	0.225	0.275	
Terminal-to-Exposed-Pad	K	0.20	-	-	

**Notes:**

1. Pin 1 visual index feature may vary, but must be located within the hatched area.
2. Package is saw singulated
3. Dimensioning and tolerancing per ASME Y14.5M
  - BSC: Basic Dimension. Theoretically exact value shown without tolerances.
  - REF: Reference Dimension, usually without tolerance, for information purposes only.

**Package Outlines and Dimensions**

**16-Lead Ultra Thin Quad Flat Pack, No Lead (MV) - 3x3x0.50 mm Body (UQFN)**

**Note:** For the most current package drawings, please see the Microchip Packaging Specification located at <http://www.microchip.com/packaging>

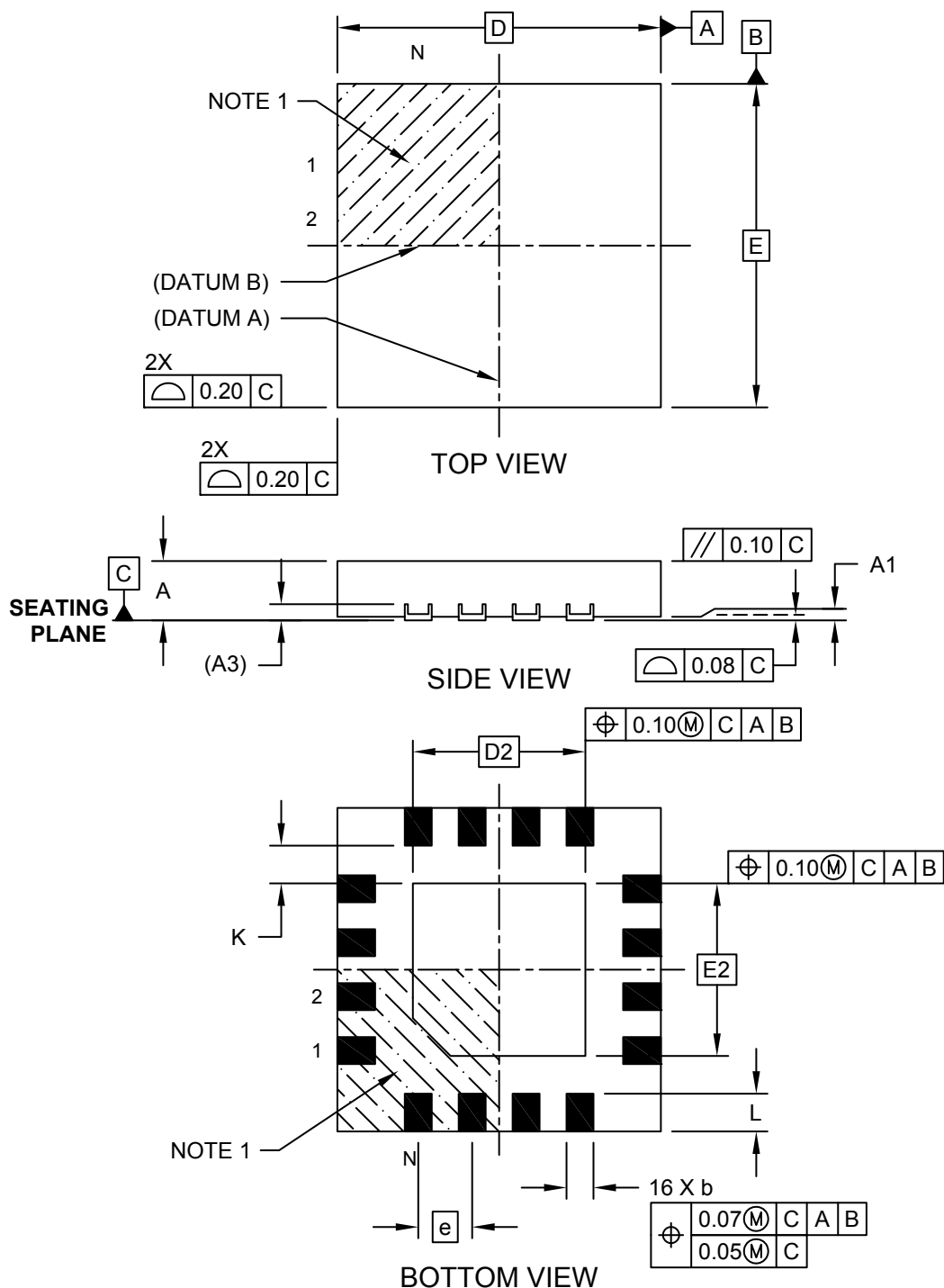

---



---

## Package Outlines and Dimensions

---



---

### 16-Lead Ultra Thin Quad Flat Pack, No Lead (MV) - 3x3x0.50 mm Body (UQFN)

**Note:** For the most current package drawings, please see the Microchip Packaging Specification located at <http://www.microchip.com/packaging>

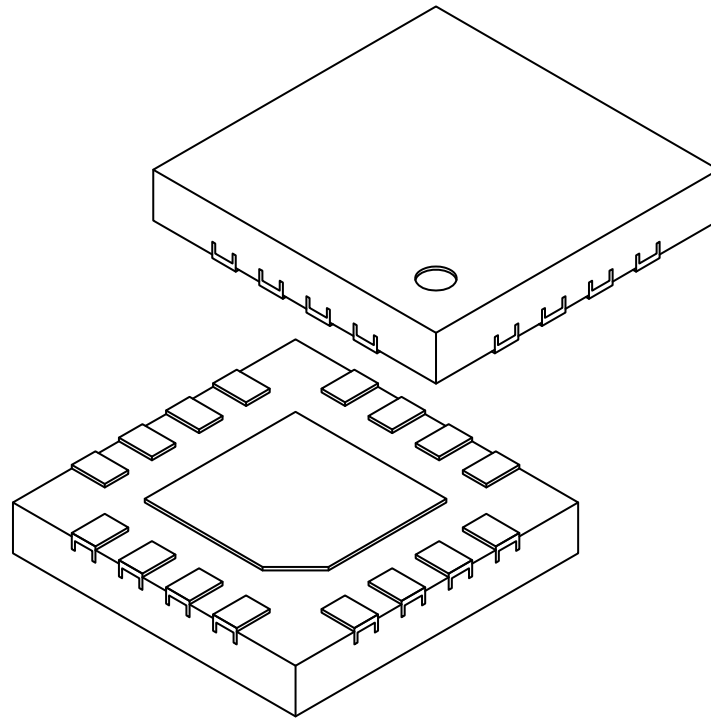

Dimension Limits	Units	MILLIMETERS		
		MIN	NOM	MAX
Number of Pins	N	16		
Pitch	e	0.50 BSC		
Overall Height	A	0.45	0.50	0.55
Standoff	A1	0.00	0.02	0.05
Terminal Thickness	(A3)	0.15 REF		
Overall Width	E	3.00 BSC		
Exposed Pad Width	E2	1.50	1.60	1.70
Overall Length	D	3.00 BSC		
Exposed Pad Length	D2	1.50	1.60	1.70
Terminal Width	b	0.20	0.25	0.30
Terminal Length	L	0.25	0.35	0.45
Terminal-to-Exposed-Pad	K	0.20	-	-

**Notes:**

1. Pin 1 visual index feature may vary, but must be located within the hatched area.
2. Package is saw singulated
3. Dimensioning and tolerancing per ASME Y14.5M
  - BSC: Basic Dimension. Theoretically exact value shown without tolerances.
  - REF: Reference Dimension, usually without tolerance, for information purposes only.

**Footprint Outlines and Dimensions**

**16-Lead Ultra Thin Quad Flat Pack, No Lead (MV) - 3x3x0.50 mm Body (UQFN)**

**Note:** For the most current package drawings, please see the Microchip Packaging Specification located at <http://www.microchip.com/packaging>

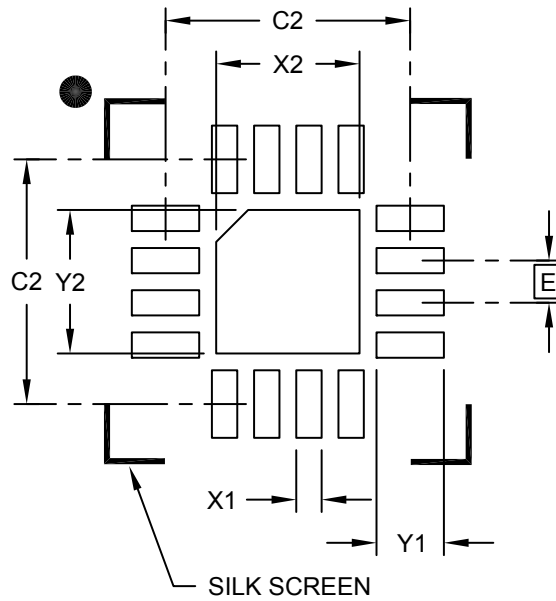

**RECOMMENDED LAND PATTERN**

Dimension Limits	Units	MILLIMETERS		
		MIN	NOM	MAX
Contact Pitch	E	0.50 BSC		
Optional Center Pad Width	X2			1.70
Optional Center Pad Length	Y2			1.70
Contact Pad Spacing	C1		2.90	
Contact Pad Spacing	C2		2.90	
Contact Pad Width (X16)	X1			0.30
Contact Pad Length (X16)	Y1			0.80

**Notes:**

1. Dimensioning and tolerancing per ASME Y14.5M

BSC: Basic Dimension. Theoretically exact value shown without tolerances.

Microchip Technology Drawing C04-2211A

**Package Outlines and Dimensions**

**16-Lead Ultra Thin Quad Flat, No Lead Package (UC) - 3x3x0.5 mm Body [UQFN]**

**Note:** For the most current package drawings, please see the Microchip Packaging Specification located at <http://www.microchip.com/packaging>

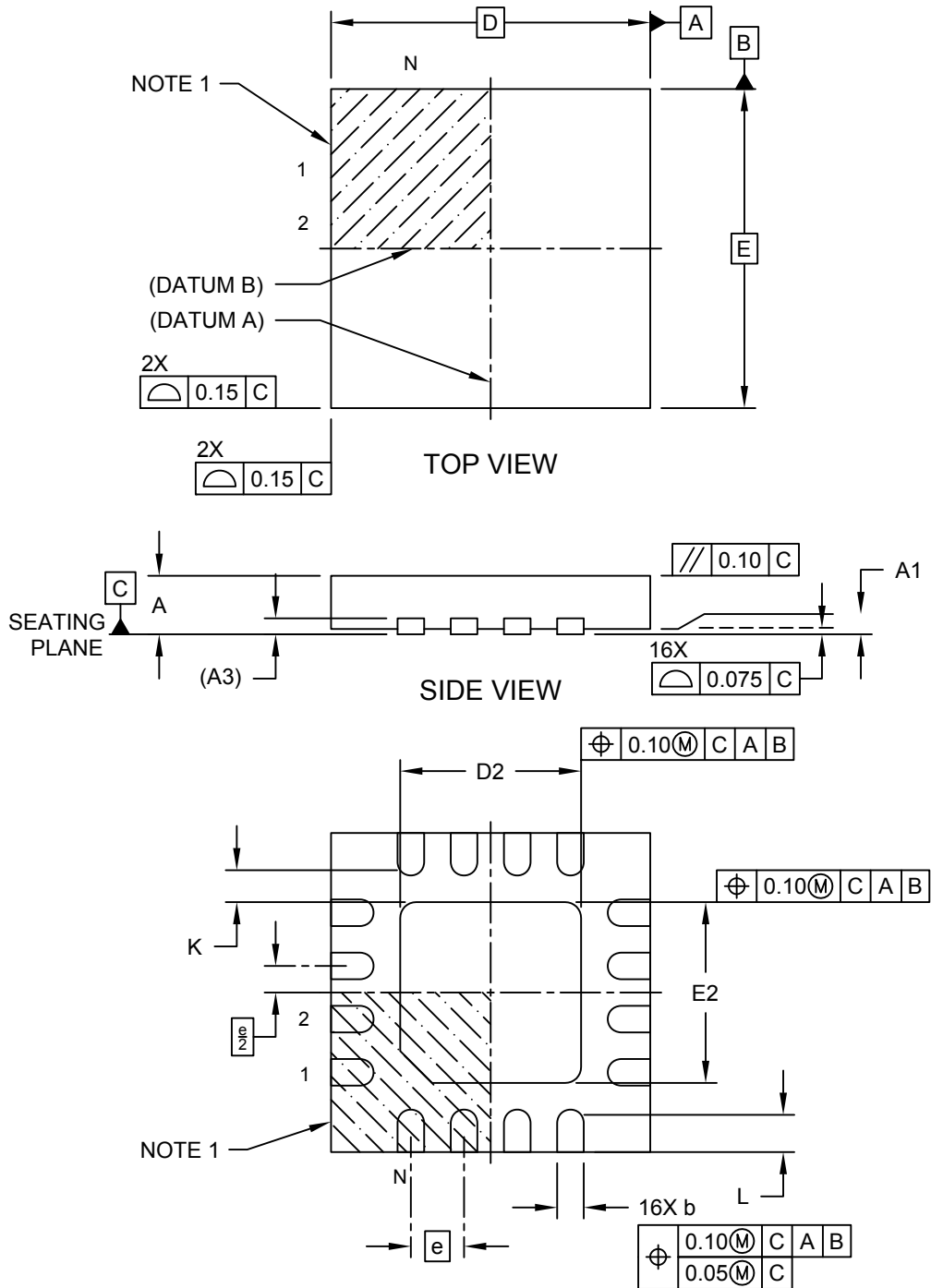

Microchip Technology Drawing C04-253A Sheet 1 of 2

**Package Outlines and Dimensions**

**16-Lead Ultra Thin Quad Flat, No Lead Package (UC) - 3x3x0.55 mm Body [UQFN]**

**Note:** For the most current package drawings, please see the Microchip Packaging Specification located at <http://www.microchip.com/packaging>

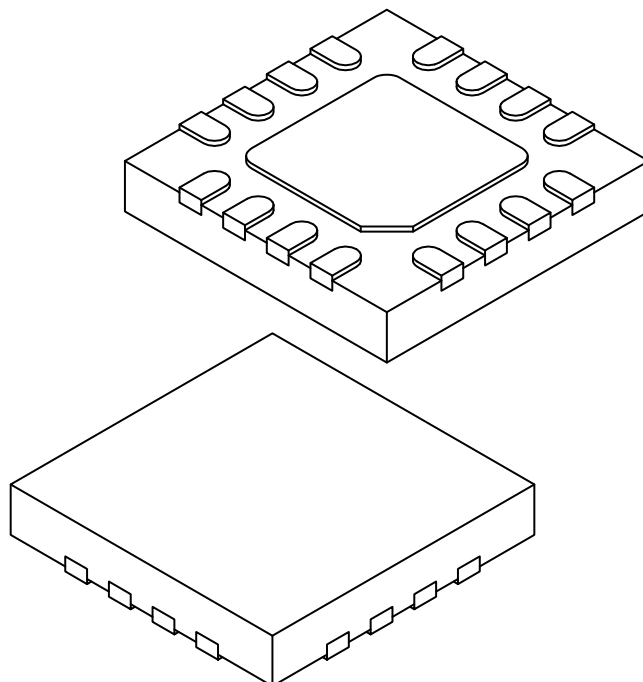

		MILLIMETERS		
Units		MIN	NOM	MAX
Dimension Limits				
Number of Terminals	N	16		
Pitch	e	0.50 BSC		
Overall Height	A	0.50	0.55	0.60
Standoff	A1	0.00	0.02	0.05
Terminal Thickness	A3	0.15 REF		
Overall Width	E	3.00 BSC		
Exposed Pad Width	E2	1.65	1.70	1.75
Overall Length	D	3.00 BSC		
Exposed Pad Length	D2	1.65	1.70	1.75
Terminal Width (X16)	b	0.20	0.25	0.30
Terminal Length (X16)	L	0.35	0.40	0.45
Terminal-to-Exposed-Pad	K	0.20	-	-

**Notes:**

1. Pin 1 visual index feature may vary, but must be located within the hatched area.
2. Package is saw singulated
3. Dimensioning and tolerancing per ASME Y14.5M

BSC: Basic Dimension. Theoretically exact value shown without tolerances.

REF: Reference Dimension, usually without tolerance, for information purposes only.



---



---

## Footprint Outlines and Dimensions

---



---

### 16-Lead Ultra Thin Quad Flat, No Lead Package (UC) - 3x3x0.55 mm Body [UQFN]

**Note:** For the most current package drawings, please see the Microchip Packaging Specification located at <http://www.microchip.com/packaging>

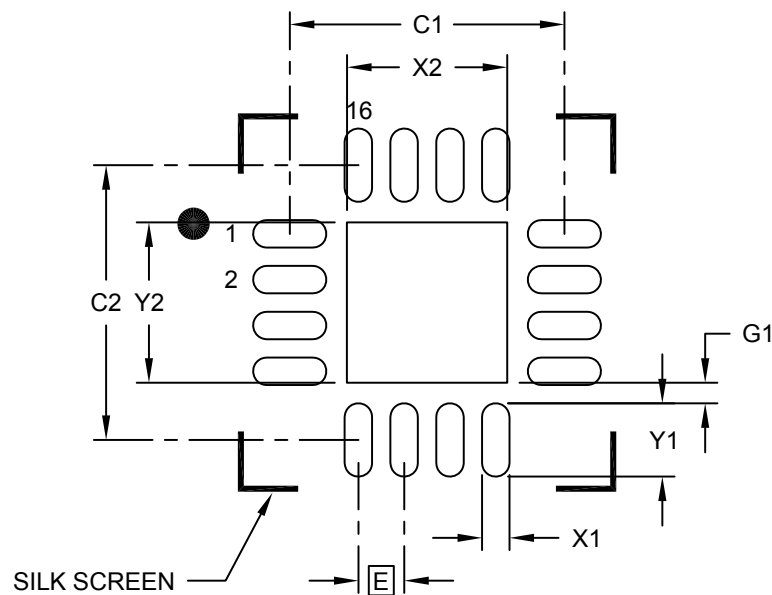

### RECOMMENDED LAND PATTERN

Dimension Limits	Units	MILLIMETERS		
		MIN	NOM	MAX
Contact Pitch	E	0.50 BSC		
Optional Center Pad Width	X2			1.75
Optional Center Pad Length	Y2			1.75
Contact Pad Spacing	C1		3.00	
Contact Pad Spacing	C2		3.00	
Contact Pad Width (X16)	X1			0.30
Contact Pad Length (X16)	Y1			0.80
Contact Pad to Center Pad (X16)	G1	0.20		

**Notes:**

1. Dimensioning and tolerancing per ASME Y14.5M

BSC: Basic Dimension. Theoretically exact value shown without tolerances.

Microchip Technology Drawing C04-2253A

**Package Outlines and Dimensions**

**16-Lead Ultra Thin Quad Flat, No Lead Package (UD) - 3x3x0.55 mm Body [UQFN]**

**Note:** For the most current package drawings, please see the Microchip Packaging Specification located at <http://www.microchip.com/packaging>

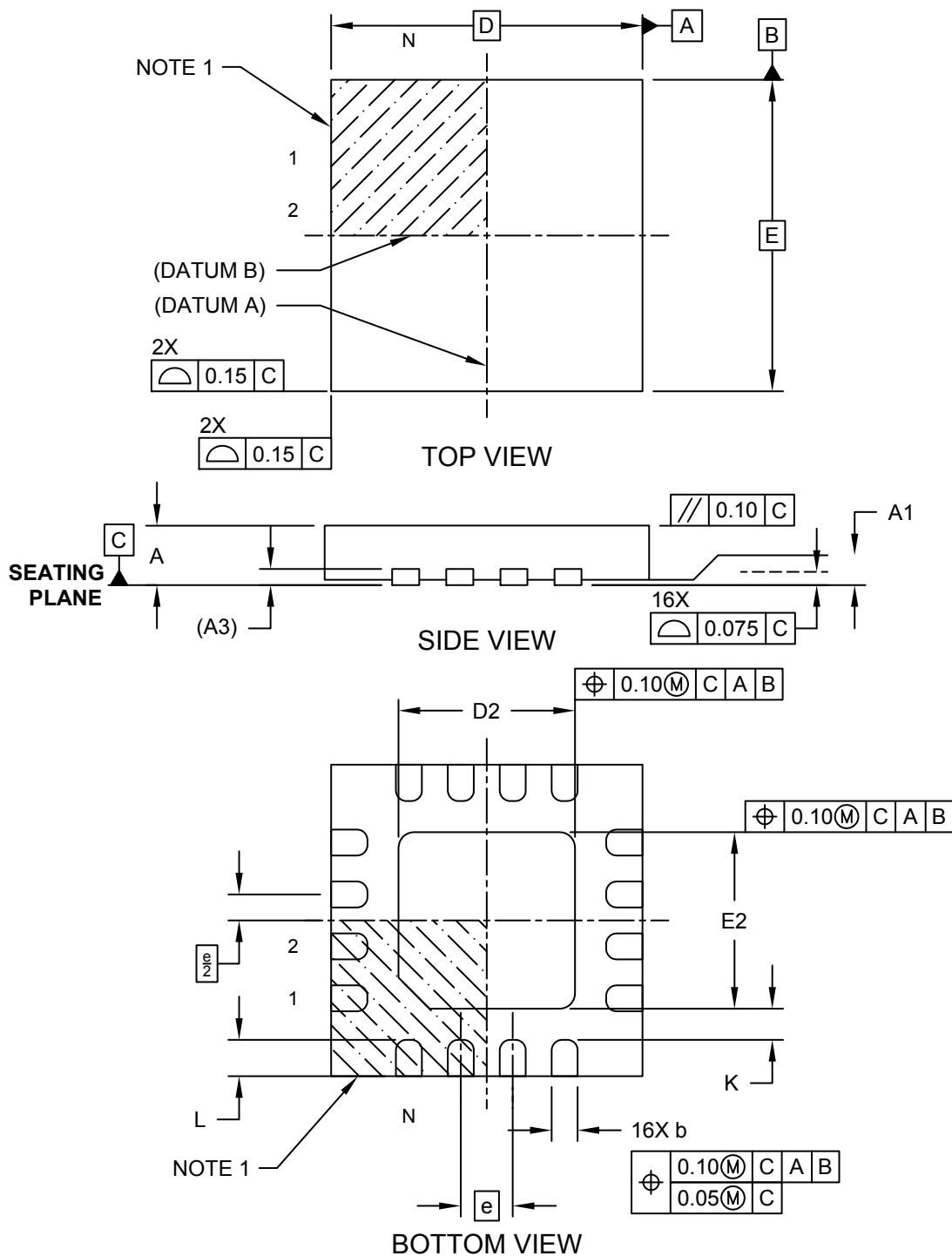

---



---

## Package Outlines and Dimensions

---



---

### 16-Lead Ultra Thin Quad Flat, No Lead Package (UD) - 3x3x0.55 mm Body [UQFN]

**Note:** For the most current package drawings, please see the Microchip Packaging Specification located at <http://www.microchip.com/packaging>

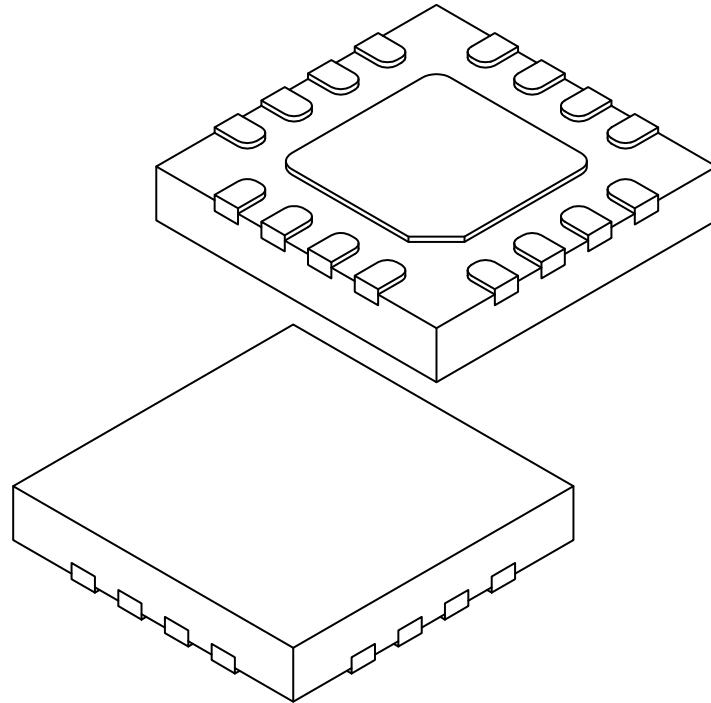

Dimension Limits	Units	MILLIMETERS		
		MIN	NOM	MAX
Number of Terminals	N	16		
Pitch	e	0.50 BSC		
Overall Height	A	0.50	0.55	0.60
Standoff	A1	0.00	0.02	0.05
Terminal Thickness	A3	0.15 REF		
Overall Width	E	3.00 BSC		
Exposed Pad Width	E2	1.65	1.70	1.75
Overall Length	D	3.00 BSC		
Exposed Pad Length	D2	1.65	1.70	1.75
Terminal Width	b	0.20	0.25	0.30
Terminal Length	L	0.30	0.35	0.40
Terminal-to-Exposed-Pad	K	0.20	-	-

**Notes:**

1. Pin 1 visual index feature may vary, but must be located within the hatched area.
2. Package is saw singulated
3. Dimensioning and tolerancing per ASME Y14.5M

BSC: Basic Dimension. Theoretically exact value shown without tolerances.

REF: Reference Dimension, usually without tolerance, for information purposes only.

**Footprint Outlines and Dimensions**

**16-Lead Ultra Thin Quad Flat, No Lead Package (UD) - 3x3x0.55 mm Body [UQFN]**

**Note:** For the most current package drawings, please see the Microchip Packaging Specification located at <http://www.microchip.com/packaging>

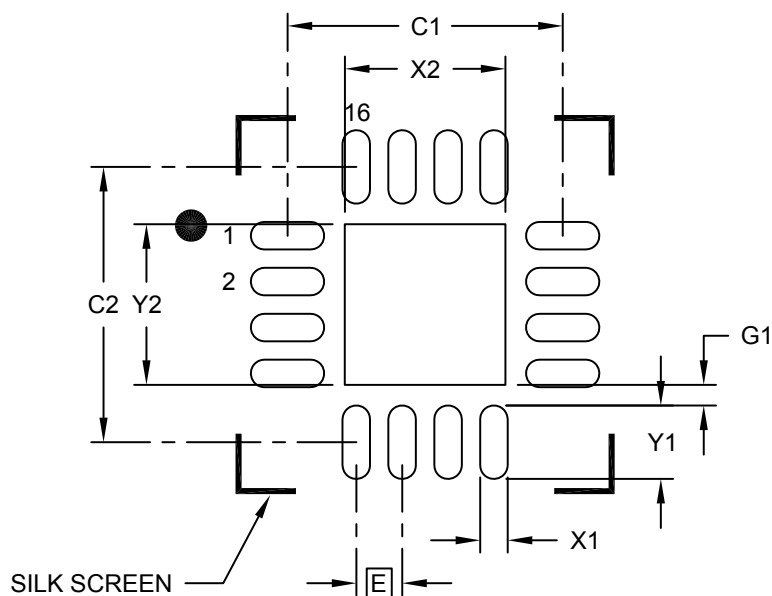

**RECOMMENDED LAND PATTERN**

Dimension Limits	Units	MILLIMETERS		
		MIN	NOM	MAX
Contact Pitch	E	0.50 BSC		
Optional Center Pad Width	X2			1.75
Optional Center Pad Length	Y2			1.75
Contact Pad Spacing	C1		3.00	
Contact Pad Spacing	C2		3.00	
Contact Pad Width (X16)	X1			0.30
Contact Pad Length (X16)	Y1			0.80
Contact Pad to Center Pad (X16)	G1	0.20		

**Notes:**

1. Dimensioning and tolerancing per ASME Y14.5M

BSC: Basic Dimension. Theoretically exact value shown without tolerances.

Microchip Technology Drawing C04-2217A

**Package Outlines and Dimensions**

**16-Lead Ultra Thin Plastic Quad Flat, No Lead Package (JQ) - 4x4x0.5 mm Body [UQFN]**

**Note:** For the most current package drawings, please see the Microchip Packaging Specification located at <http://www.microchip.com/packaging>

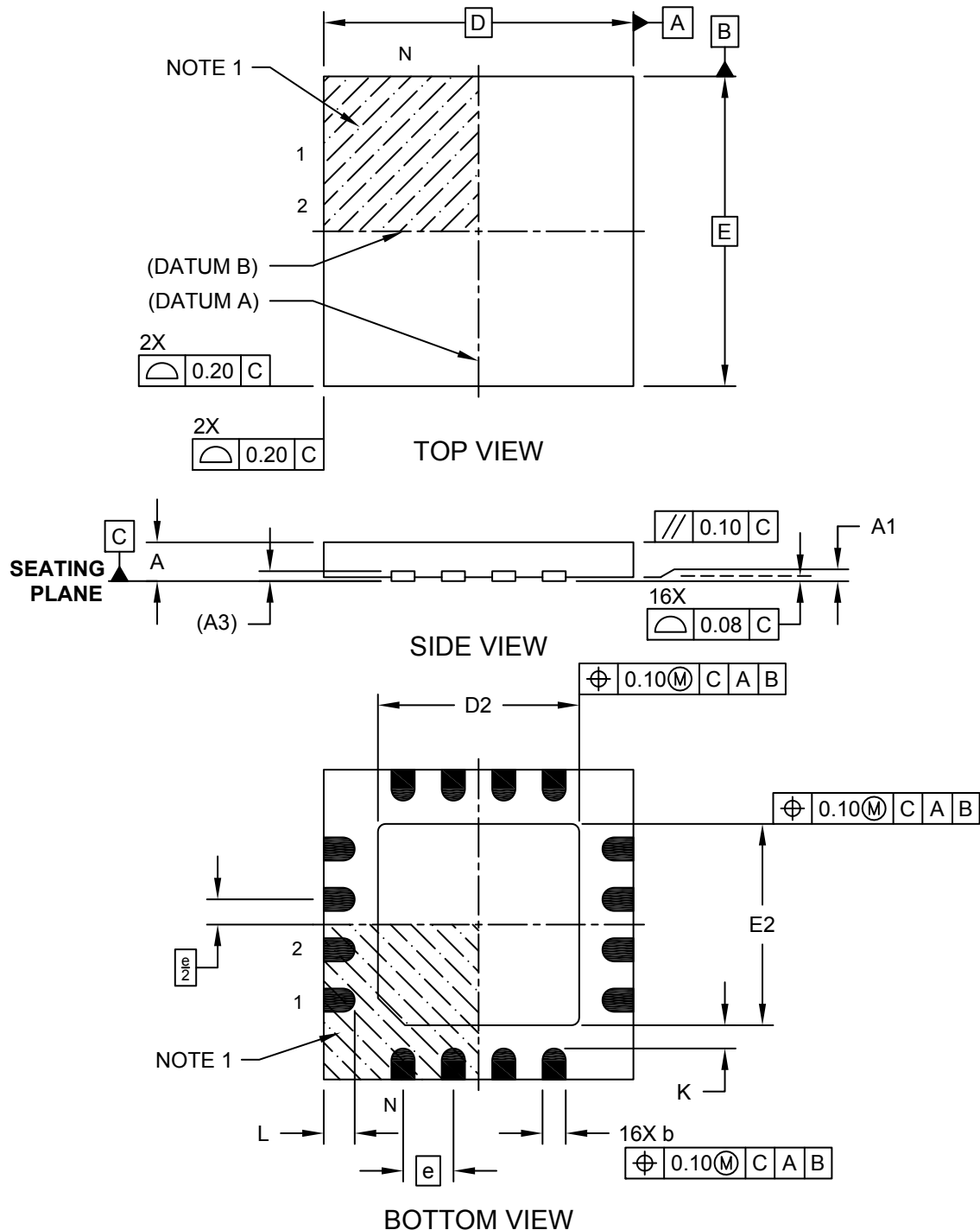

**Package Outlines and Dimensions**

**16-Lead Ultra Thin Plastic Quad Flat, No Lead Package (JQ) - 4x4x0.5 mm Body [UQFN]**

**Note:** For the most current package drawings, please see the Microchip Packaging Specification located at <http://www.microchip.com/packaging>

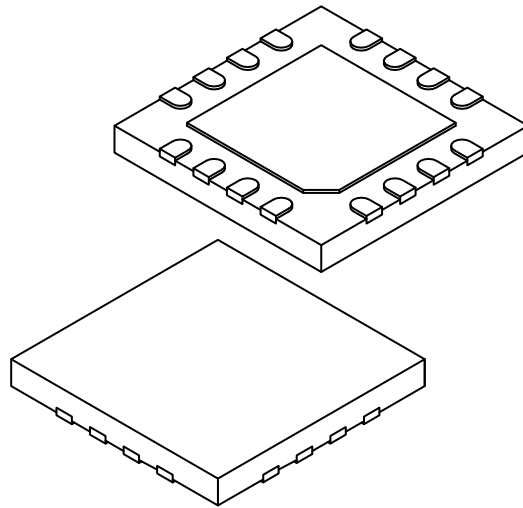

		Units	MILLIMETERS		
Dimension Limits			MIN	NOM	MAX
Number of Pins	N		16		
Pitch	e		0.65 BSC		
Overall Height	A		0.45	0.50	0.55
Standoff	A1		0.00	0.02	0.05
Terminal Thickness	A3		0.127 REF		
Overall Width	E		4.00 BSC		
Exposed Pad Width	E2		2.50	2.60	2.70
Overall Length	D		4.00 BSC		
Exposed Pad Length	D2		2.50	2.60	2.70
Terminal Width	b		0.25	0.30	0.35
Terminal Length	L		0.30	0.40	0.50
Terminal-to-Exposed-Pad	K		0.20	-	-

**Notes:**

1. Pin 1 visual index feature may vary, but must be located within the hatched area.
2. Package is saw singulated
3. Dimensioning and tolerancing per ASME Y14.5M

BSC: Basic Dimension. Theoretically exact value shown without tolerances.

REF: Reference Dimension, usually without tolerance, for information purposes only.

---



---

## Footprint Outlines and Dimensions

---



---

### 16-Lead Ultra Thin Plastic Quad Flat, No Lead Package (JQ) - 4x4x0.5 mm Body [UQFN]

**Note:** For the most current package drawings, please see the Microchip Packaging Specification located at <http://www.microchip.com/packaging>

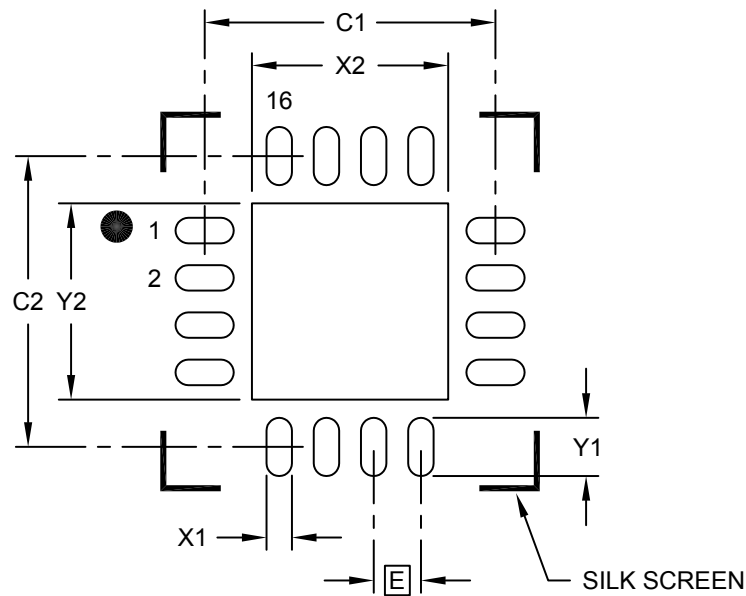

**RECOMMENDED LAND PATTERN**

Dimension Limits	Units	MILLIMETERS		
		MIN	NOM	MAX
Contact Pitch	E	0.65 BSC		
Optional Center Pad Width	X2			2.70
Optional Center Pad Length	Y2			2.70
Contact Pad Spacing	C1		4.00	
Contact Pad Spacing	C2		4.00	
Contact Pad Width (X16)	X1			0.35
Contact Pad Length (X16)	Y1			0.80

**Notes:**

1. Dimensioning and tolerancing per ASME Y14.5M

BSC: Basic Dimension. Theoretically exact value shown without tolerances.

Microchip Technology Drawing C04-2257A

**Package Outlines and Dimensions**

**20-Lead Ultra Thin Plastic Quad Flat, No Lead Package (NC) - 3x3 mm Body [UQFN]  
(Formerly Q3DE; SST Legacy Package)**

**Note:** For the most current package drawings, please see the Microchip Packaging Specification located at <http://www.microchip.com/packaging>

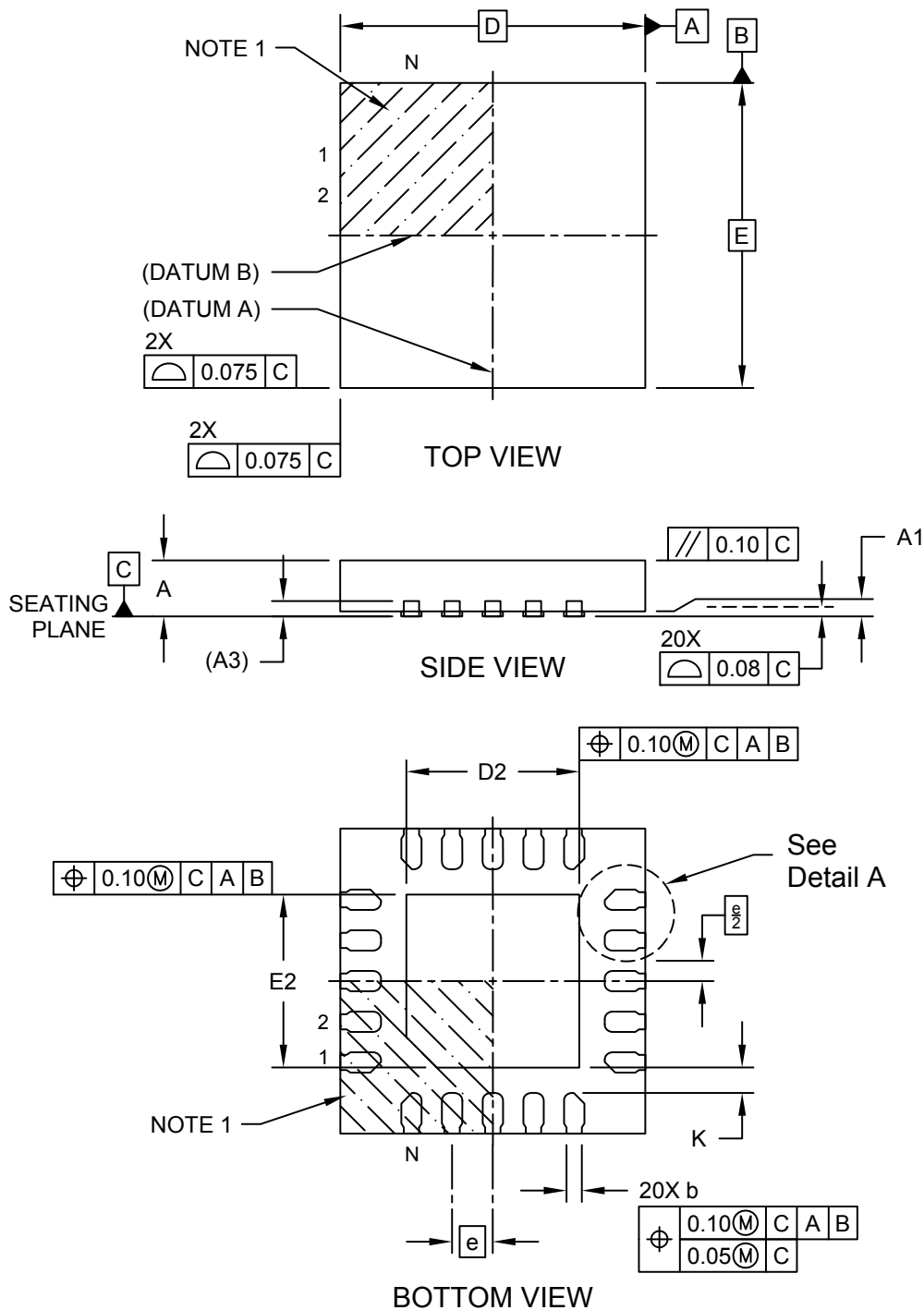



---



---

## Package Outlines and Dimensions

---



---

### 20-Lead Ultra Thin Plastic Quad Flat, No Lead Package (NC) - 3x3 mm Body [UQFN] (Formerly Q3DE; SST Legacy Package)

**Note:** For the most current package drawings, please see the Microchip Packaging Specification located at <http://www.microchip.com/packaging>

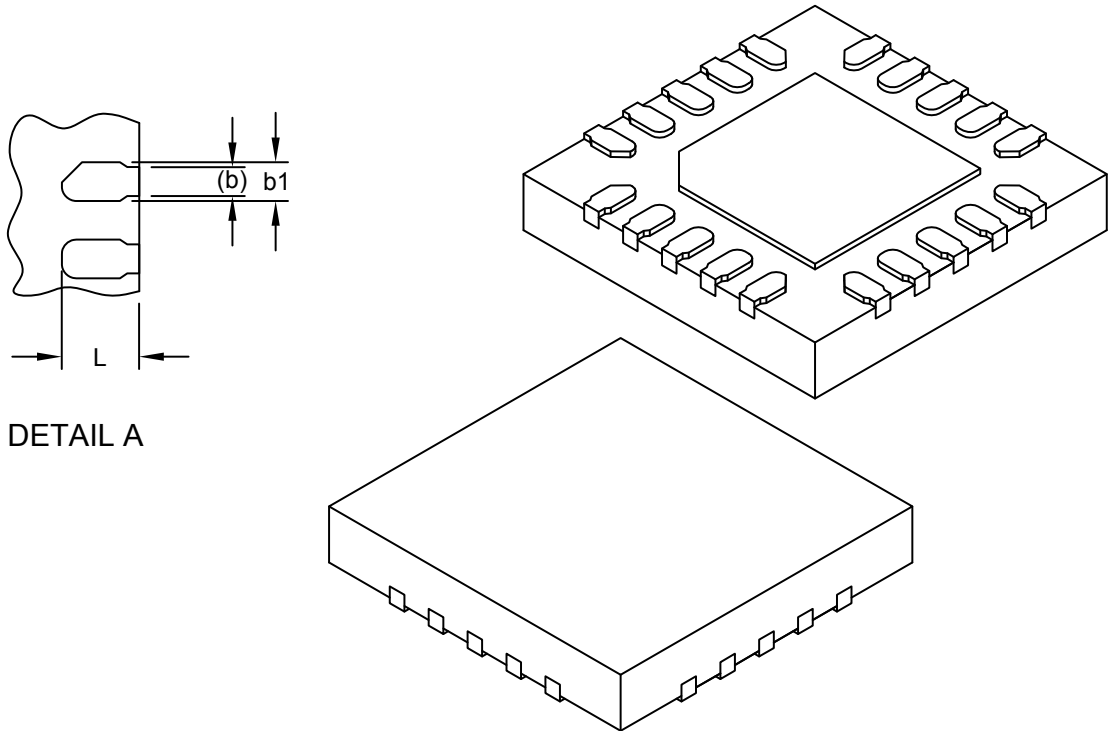

Dimension Limits	Units	MILLIMETERS		
		MIN	NOM	MAX
Number of Terminals	N	20		
Pitch	e	0.40 BSC		
Overall Height	A	0.50	0.55	0.60
Standoff	A1	0.00	0.02	0.05
Terminal Thickness	A3	0.15 REF		
Overall Length	D	3.00 BSC		
Exposed Pad Length	D2	1.60	1.70	1.80
Overall Width	E	3.00 BSC		
Exposed Pad Width	E2	1.60	1.70	1.80
Terminal Width (Inner)	b	0.15 REF		
Terminal Width (Outer)	b1	0.15	0.20	0.25
Terminal Length	L	0.35	0.40	0.45
Terminal-to-Exposed-Pad	K	0.20	-	-

**Notes:**

1. Pin 1 visual index feature may vary, but must be located within the hatched area.
2. Package is saw singulated
3. Dimensioning and tolerancing per ASME Y14.5M
  - BSC: Basic Dimension. Theoretically exact value shown without tolerances.
  - REF: Reference Dimension, usually without tolerance, for information purposes only.

**Footprint Outlines and Dimensions**

**20-Lead Ultra Thin Plastic Quad Flat, No Lead Package (NC) - 3x3 mm Body [UQFN]  
(Formerly Q3DE; SST Legacy Package)**

**Note:** For the most current package drawings, please see the Microchip Packaging Specification located at <http://www.microchip.com/packaging>

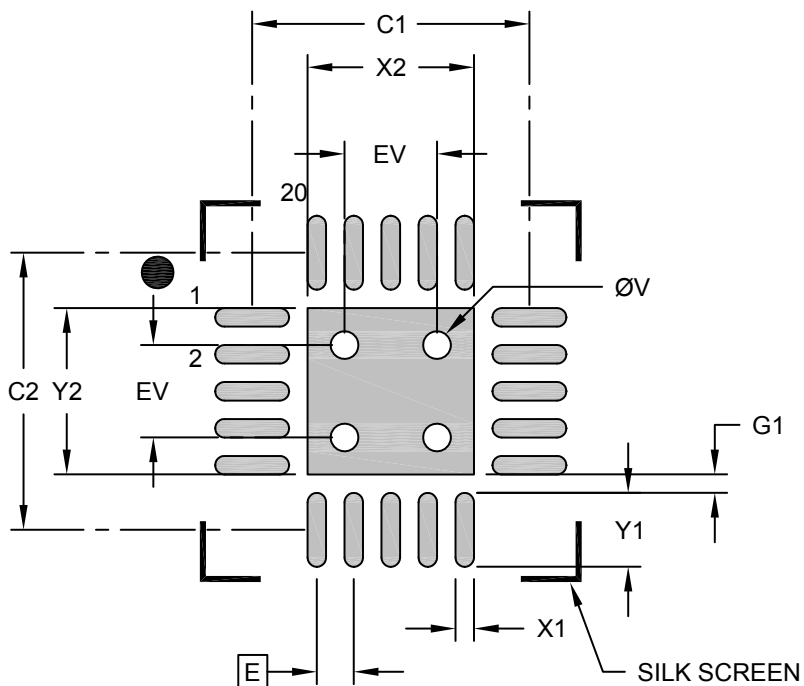

**RECOMMENDED LAND PATTERN**

Dimension	Units	MILLIMETERS		
		MIN	NOM	MAX
Contact Pitch	E	0.40 BSC		
Optional Center Pad Width	X2			1.80
Optional Center Pad Length	Y2			1.80
Contact Pad Spacing	C1		3.00	
Contact Pad Spacing	C2		3.00	
Contact Pad Width (X20)	X1			0.20
Contact Pad Length (X20)	Y1			0.80
Contact Pad to Center Pad (X20)	G1	0.20		
Thermal Via Diameter	V		0.30	
Thermal Via Pitch	EV		1.00	

**Notes:**

1. Dimensioning and tolerancing per ASME Y14.5M  
BSC: Basic Dimension. Theoretically exact value shown without tolerances.
2. For best soldering results, thermal vias, if used, should be filled or tented to avoid solder loss during reflow process

**Package Outlines and Dimensions**

**20-Lead Ultra Thin Plastic Quad Flat, No Lead Package (JP) - 3x3x0.50 mm Body [UQFN]**

**Note:** For the most current package drawings, please see the Microchip Packaging Specification located at <http://www.microchip.com/packaging>

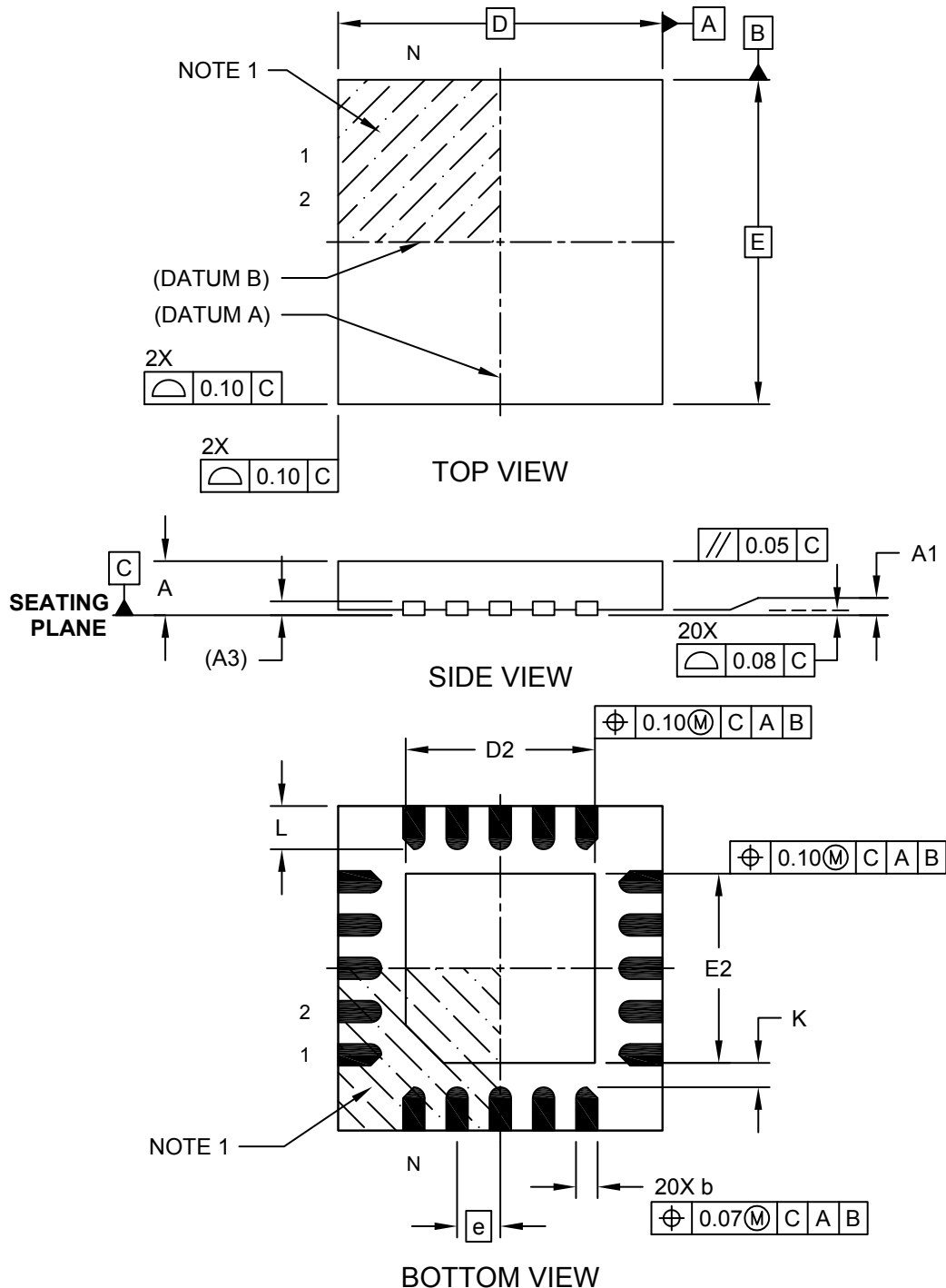

**Package Outlines and Dimensions**

**20-Lead Ultra Thin Plastic Quad Flat, No Lead Package (JP) - 3x3x0.50 mm Body [UQFN]**

**Note:** For the most current package drawings, please see the Microchip Packaging Specification located at <http://www.microchip.com/packaging>

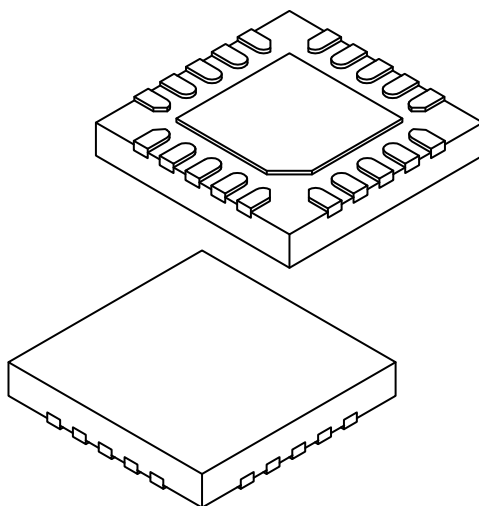

Dimension Limits	Units	MILLIMETERS		
		MIN	NOM	MAX
Number of Terminals	N	20		
Pitch	e	0.40		
Overall Height	A	0.45	0.50	0.55
Standoff	A1	0.00	0.02	0.05
Terminal Thickness	A3	0.127 REF		
Overall Width	E	3.00 BSC		
Exposed Pad Width	E2	1.65	1.75	1.85
Overall Length	D	3.00 BSC		
Exposed Pad Length	D2	1.65	1.75	1.85
Terminal Width	b	0.15	0.20	0.25
Terminal Length	L	0.30	0.40	0.50
Terminal-to-Exposed-Pad	K	0.20	-	-

**Notes:**

1. Pin 1 visual index feature may vary, but must be located within the hatched area.
2. Package is saw singulated
3. Dimensioning and tolerancing per ASME Y14.5M

BSC: Basic Dimension. Theoretically exact value shown without tolerances.

REF: Reference Dimension, usually without tolerance, for information purposes only.

---



---

## Footprint Outlines and Dimensions

---



---

### 20-Lead Ultra Thin Plastic Quad Flat, No Lead Package (JP) - 3x3x0.5 mm Body [UQFN]

**Note:** For the most current package drawings, please see the Microchip Packaging Specification located at <http://www.microchip.com/packaging>

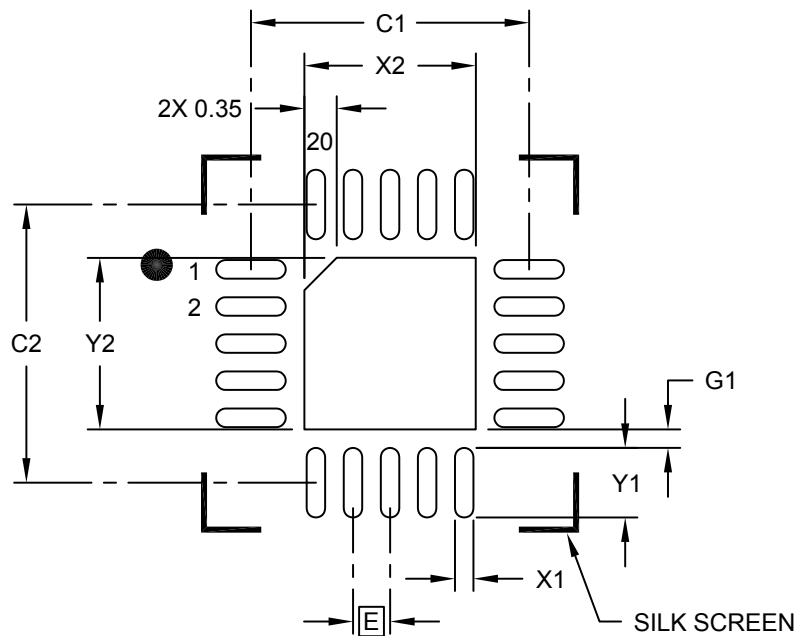

### RECOMMENDED LAND PATTERN

Dimension Limits	Units	MILLIMETERS		
		MIN	NOM	MAX
Contact Pitch	E	0.40 BSC		
Optional Center Pad Width	X2			1.85
Optional Center Pad Length	Y2			1.85
Contact Pad Spacing	C1		3.00	
Contact Pad Spacing	C2		3.00	
Contact Pad Width (X20)	X1			0.20
Contact Pad Length (X20)	Y1			0.75
Contact Pad to Center Pad (X20)	G1	0.20		

**Notes:**

1. Dimensioning and tolerancing per ASME Y14.5M

BSC: Basic Dimension. Theoretically exact value shown without tolerances.

Microchip Technology Drawing C04-2256A

**Package Outlines and Dimensions**

**20-Lead Ultra Thin Plastic Quad Flat, No Lead Package (GZ) - 4x4x0.5 mm Body [UQFN]**

**Note:** For the most current package drawings, please see the Microchip Packaging Specification located at <http://www.microchip.com/packaging>

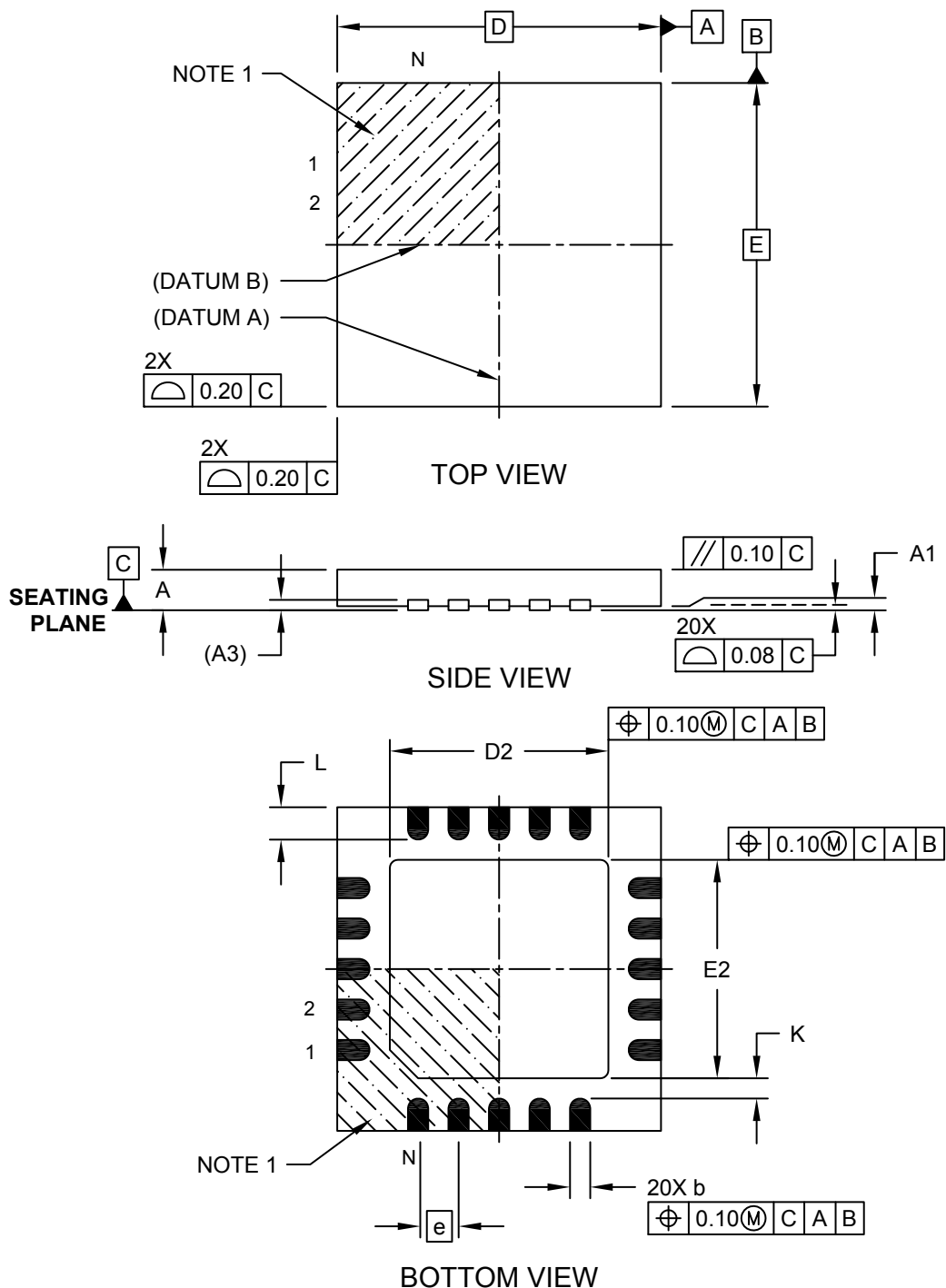

---



---

## Package Outlines and Dimensions

---



---

### 20-Lead Ultra Thin Plastic Quad Flat, No Lead Package (GZ) - 4x4x0.5 mm Body [UQFN]

**Note:** For the most current package drawings, please see the Microchip Packaging Specification located at <http://www.microchip.com/packaging>

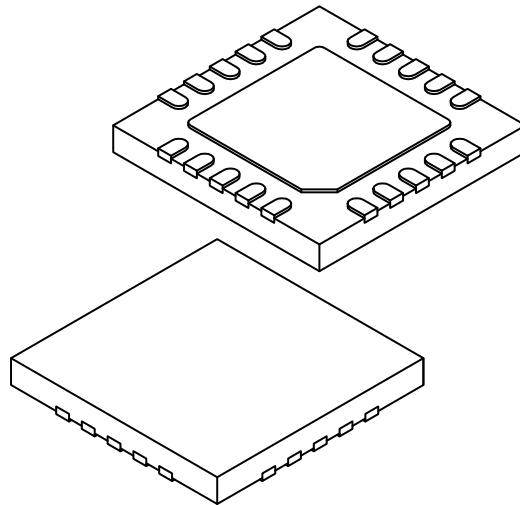

		Units	MILLIMETERS		
Dimension Limits			MIN	NOM	MAX
Number of Terminals	N		20		
Pitch	e		0.50 BSC		
Overall Height	A		0.45	0.50	0.55
Standoff	A1		0.00	0.02	0.05
Terminal Thickness	A3		0.127 REF		
Overall Width	E		4.00 BSC		
Exposed Pad Width	E2		2.60	2.70	2.80
Overall Length	D		4.00 BSC		
Exposed Pad Length	D2		2.60	2.70	2.80
Terminal Width	b		0.20	0.25	0.30
Terminal Length	L		0.30	0.40	0.50
Terminal-to-Exposed-Pad	K		0.20	-	-

**Notes:**

1. Pin 1 visual index feature may vary, but must be located within the hatched area.
2. Package is saw singulated
3. Dimensioning and tolerancing per ASME Y14.5M

BSC: Basic Dimension. Theoretically exact value shown without tolerances.

REF: Reference Dimension, usually without tolerance, for information purposes only.

**Footprint Outlines and Dimensions**

**20-Lead Ultra Thin Plastic Quad Flat, No Lead Package (GZ) - 4x4x0.5 mm Body [UQFN]**

**Note:** For the most current package drawings, please see the Microchip Packaging Specification located at <http://www.microchip.com/packaging>

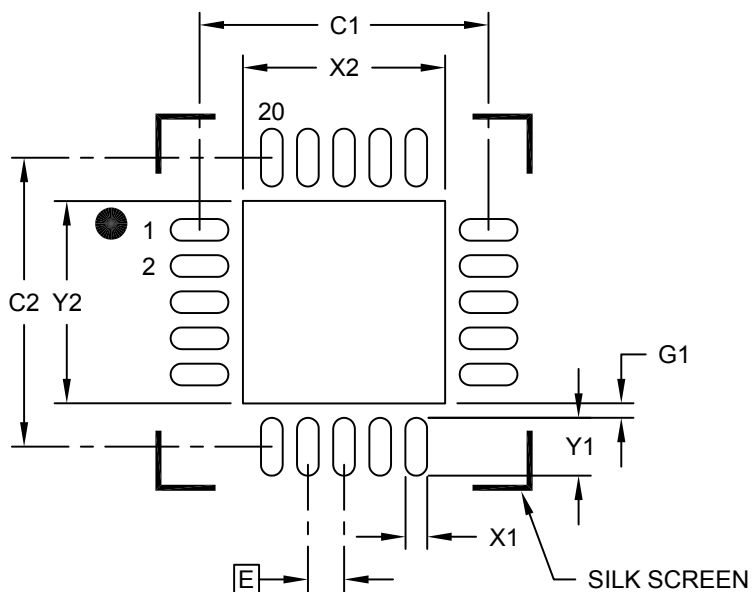

**RECOMMENDED LAND PATTERN**

Units		MILLIMETERS		
Dimension Limits		MIN	NOM	MAX
Contact Pitch	E	0.50 BSC		
Optional Center Pad Width	X2			2.80
Optional Center Pad Length	Y2			2.80
Contact Pad Spacing	C1		4.00	
Contact Pad Spacing	C2		4.00	
Contact Pad Width (X20)	X1			0.30
Contact Pad Length (X20)	Y1			0.80
Contact Pad to Center Pad (X20)	G1	0.20		

Notes:

1. Dimensioning and tolerancing per ASME Y14.5M

BSC: Basic Dimension. Theoretically exact value shown without tolerances.

Microchip Technology Drawing C04-2255A



---



---

## Package Outlines and Dimensions

---



---

### 20-Lead Ultra Thin Quad Flat Pack, No Lead (GN) - 4x4x0.55 mm Body (UQFN)

**Note:** For the most current package drawings, please see the Microchip Packaging Specification located at <http://www.microchip.com/packaging>

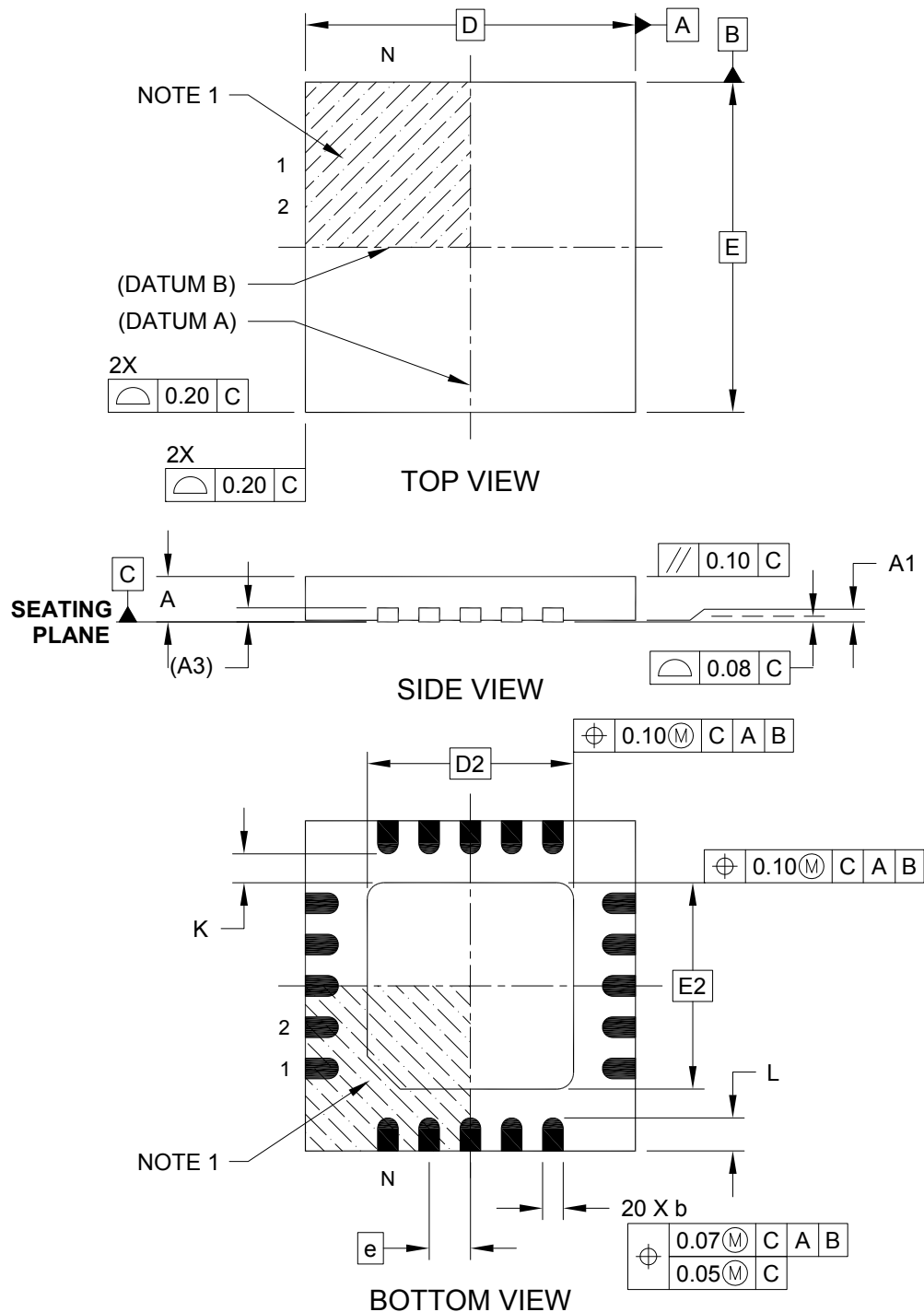

**Package Outlines and Dimensions**

**20-Lead Ultra Thin Quad Flat Pack, No Lead (GN) - 4x4x0.55 mm Body (UQFN)**

**Note:** For the most current package drawings, please see the Microchip Packaging Specification located at <http://www.microchip.com/packaging>

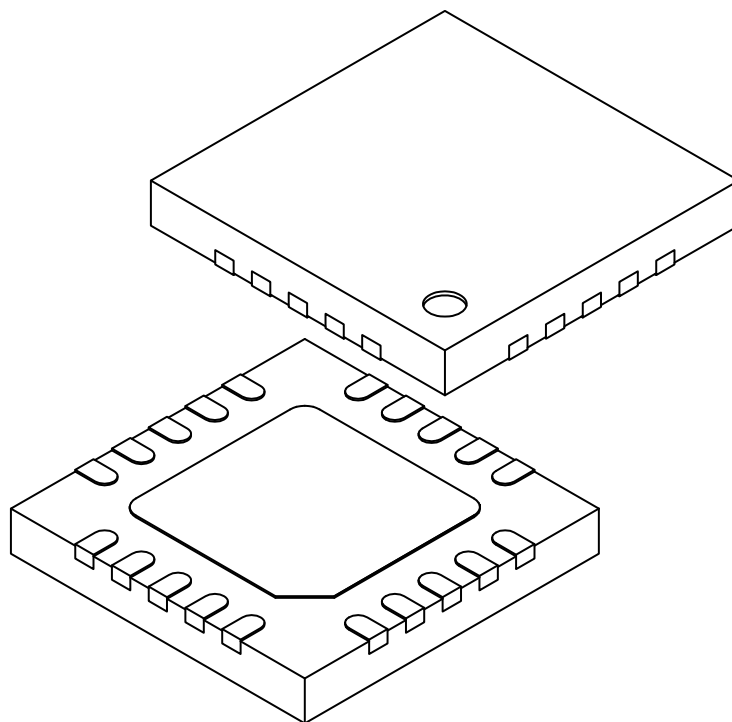

Dimension Limits		MILLIMETERS		
		MIN	NOM	MAX
Number of Pins	N	20		
Pitch	e	0.50 BSC		
Overall Height	A	0.50	0.55	0.60
Standoff	A1	0.00	0.02	0.05
Terminal Thickness	(A3)	0.15 REF		
Overall Width	E	4.00 BSC		
Exposed Pad Width	E2	2.45	2.50	2.55
Overall Length	D	4.00 BSC		
Exposed Pad Length	D2	2.45	2.50	2.55
Terminal Width	b	0.20	0.25	0.30
Terminal Length	L	0.35	0.40	0.45
Terminal-to-Exposed-Pad	K	0.20	-	-

**Notes:**

- Pin 1 visual index feature may vary, but must be located within the hatched area.
- Package is saw singulated
- Dimensioning and tolerancing per ASME Y14.5M

BSC: Basic Dimension. Theoretically exact value shown without tolerances.

REF: Reference Dimension, usually without tolerance, for information purposes only.

**Package Outlines and Dimensions**

**28-Lead Plastic Ultra Thin Quad Flat, No Lead Package (MV) – 4x4x0.5 mm Body [UQFN]**

**Note:** For the most current package drawings, please see the Microchip Packaging Specification located at <http://www.microchip.com/packaging>

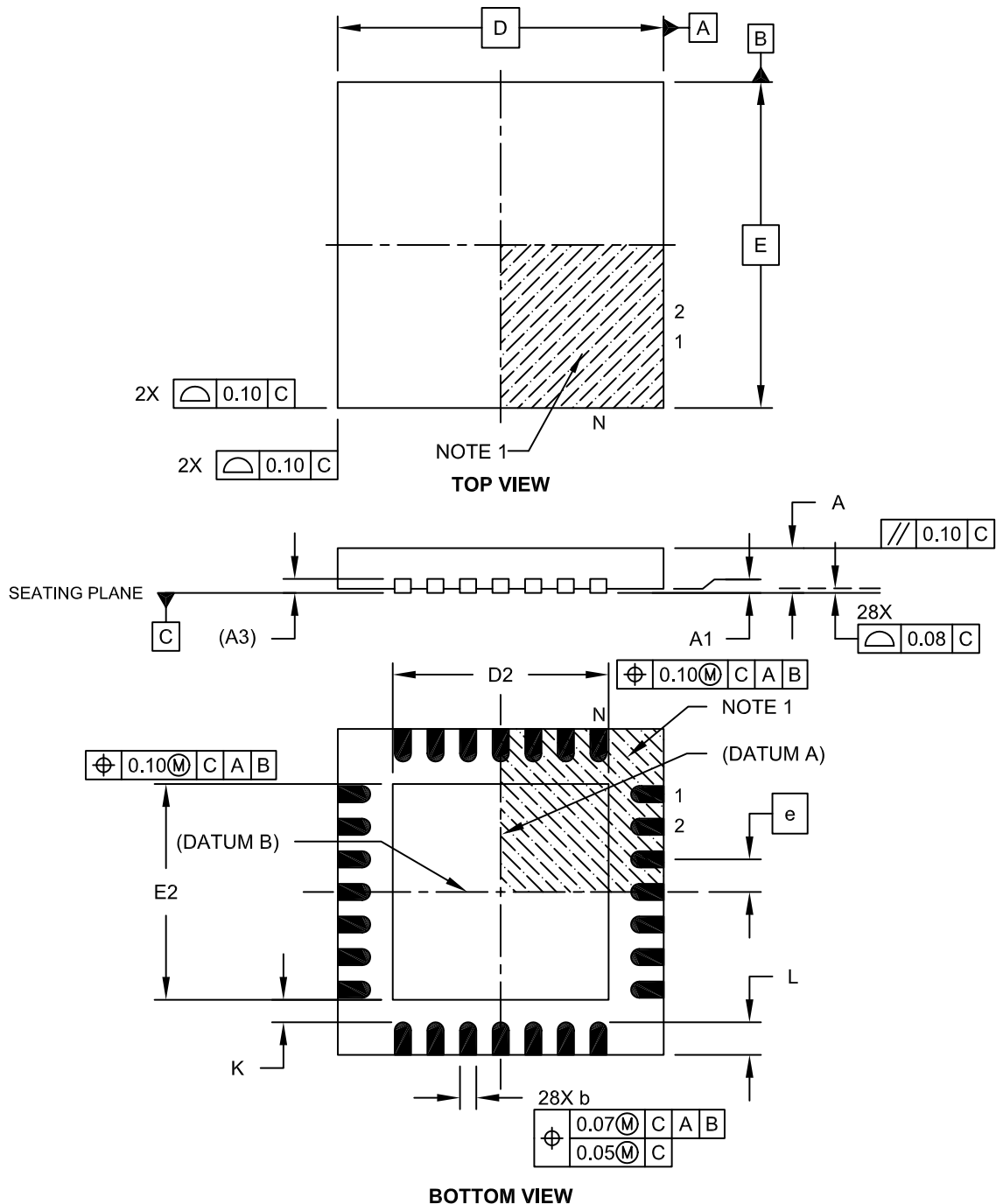

**Package Outlines and Dimensions**

**28-Lead Plastic Ultra Thin Quad Flat, No Lead Package (MV) – 4x4x0.5 mm Body [UQFN]**

**Note:** For the most current package drawings, please see the Microchip Packaging Specification located at <http://www.microchip.com/packaging>

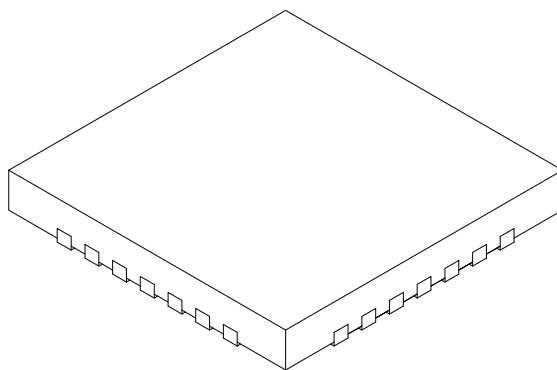

Dimension Limits	Units	MILLIMETERS		
		MIN	NOM	MAX
Number of Pins	N	28		
Pitch	e	0.40 BSC		
Overall Height	A	0.45	0.50	0.55
Standoff	A1	0.00	0.02	0.05
Contact Thickness	A3	0.127 REF		
Overall Width	E	4.00 BSC		
Exposed Pad Width	E2	2.55	2.65	2.75
Overall Length	D	4.00 BSC		
Exposed Pad Length	D2	2.55	2.65	2.75
Contact Width	b	0.15	0.20	0.25
Contact Length	L	0.30	0.40	0.50
Contact-to-Exposed Pad	K	0.20	-	-

**Notes:**

1. Pin 1 visual index feature may vary, but must be located within the hatched area.
2. Package is saw singulated.
3. Dimensioning and tolerancing per ASME Y14.5M.

BSC: Basic Dimension. Theoretically exact value shown without tolerances.

REF: Reference Dimension, usually without tolerance, for information purposes only.

---



---

## Footprint Outlines and Dimensions

---



---

### 28-Lead Ultra Thin Plastic Quad Flat, No Lead Package (MV) - 4x4 mm Body [UQFN] With 0.40 mm Contact Length

**Note:** For the most current package drawings, please see the Microchip Packaging Specification located at <http://www.microchip.com/packaging>

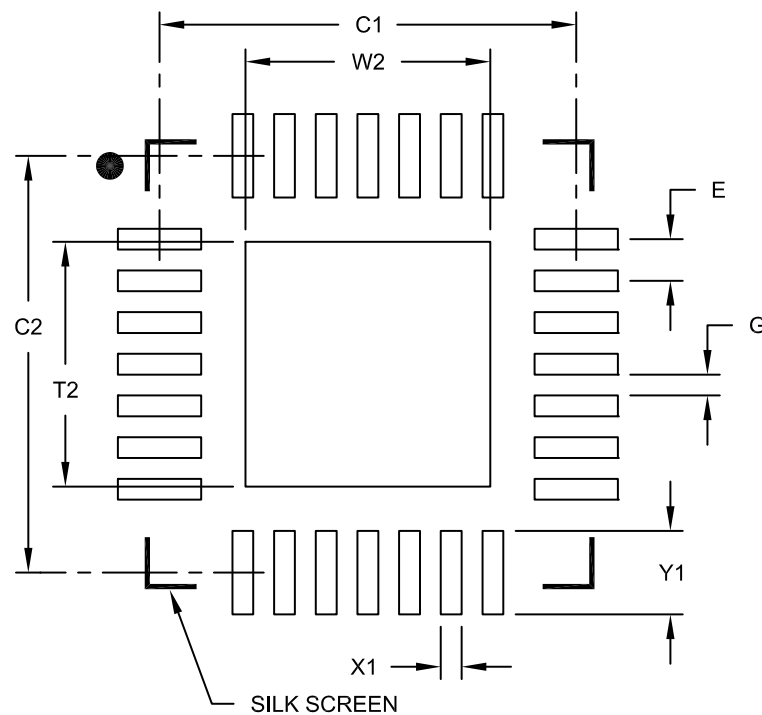

**RECOMMENDED LAND PATTERN**

Dimension Limits	Units	MILLIMETERS		
		MIN	NOM	MAX
Contact Pitch	E	0.40 BSC		
Optional Center Pad Width	W2			2.35
Optional Center Pad Length	T2			2.35
Contact Pad Spacing	C1		4.00	
Contact Pad Spacing	C2		4.00	
Contact Pad Width (X28)	X1			0.20
Contact Pad Length (X28)	Y1			0.80
Distance Between Pads	G	0.20		

**Notes:**

1. Dimensioning and tolerancing per ASME Y14.5M

BSC: Basic Dimension. Theoretically exact value shown without tolerances.

Microchip Technology Drawing No. C04-2152A

**Package Outlines and Dimensions**

**28-Lead Ultra Thin Plastic Quad Flat, No Lead Package (PW) - 4x4x0.6 mm Body [UQFN] With Corner Anchors**

**Note:** For the most current package drawings, please see the Microchip Packaging Specification located at <http://www.microchip.com/packaging>

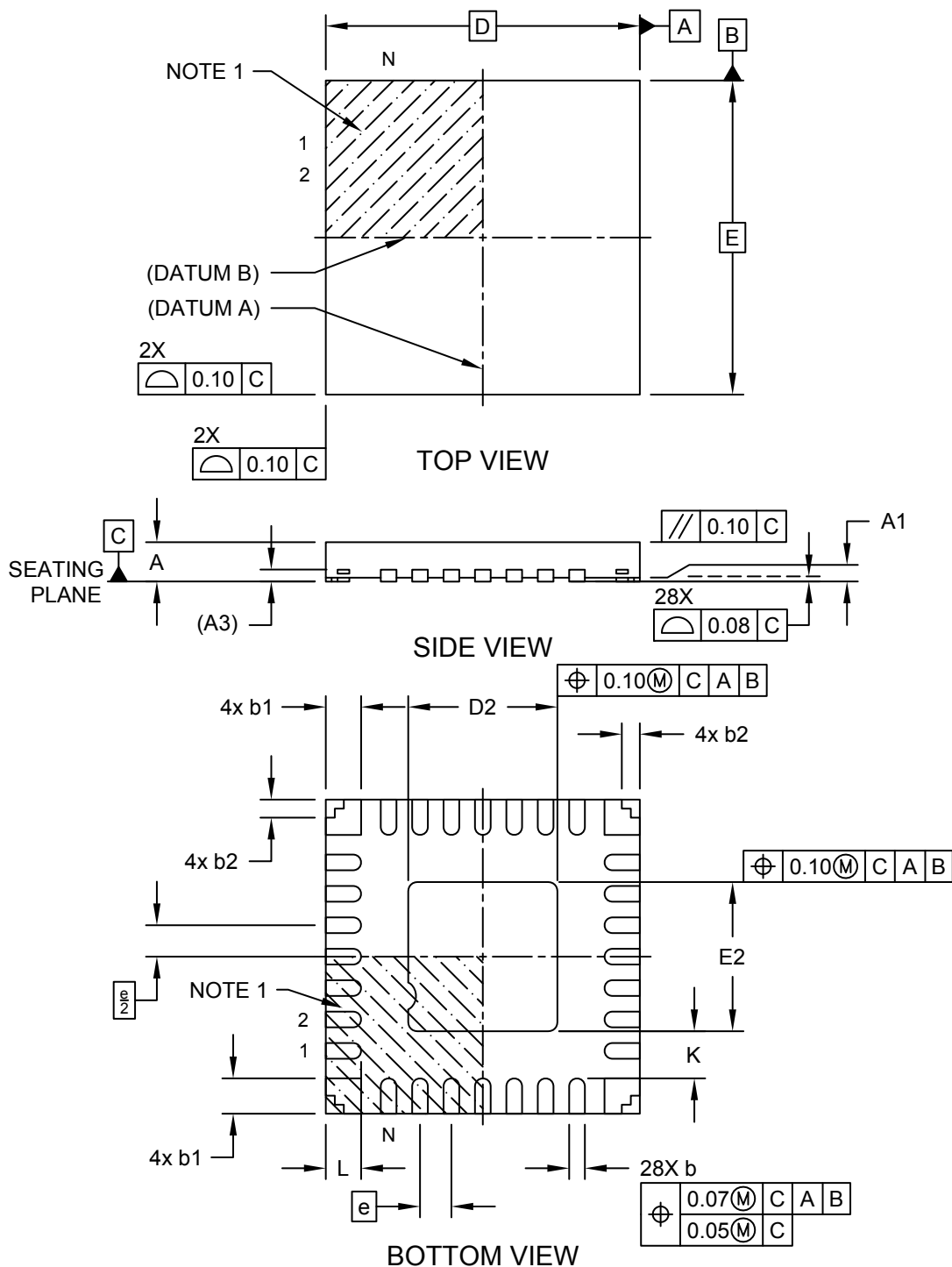

---



---

## Package Outlines and Dimensions

---



---

### 28-Lead Ultra Thin Plastic Quad Flat, No Lead Package (PW) - 4x4x0.6 mm Body [UQFN] With Corner Anchors

**Note:** For the most current package drawings, please see the Microchip Packaging Specification located at <http://www.microchip.com/packaging>

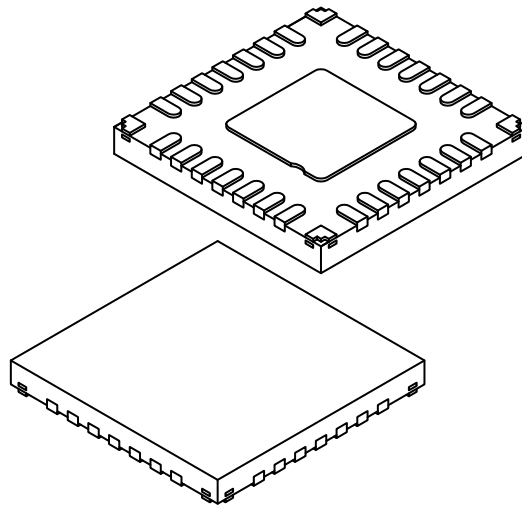

Dimension Limits	Units	MILLIMETERS		
		MIN	NOM	MAX
Number of Pins	N	28		
Pitch	e	0.40 BSC		
Overall Height	A	-	-	0.60
Standoff	A1	0.00	0.02	0.05
Terminal Thickness	A3	0.152 REF		
Overall Width	E	4.00 BSC		
Exposed Pad Width	E2	1.80	1.90	2.00
Overall Length	D	4.00 BSC		
Exposed Pad Length	D2	1.80	1.90	2.00
Terminal Width	b	0.15	0.20	0.25
Corner Anchor Pad	b1	0.40	0.45	0.50
Corner Pad, Metal Free Zone	b2	0.18	0.23	0.28
Terminal Length	L	0.30	0.45	0.50
Terminal-to-Exposed-Pad	K	-	0.60	-

**Notes:**

1. Pin 1 visual index feature may vary, but must be located within the hatched area.
2. Package is saw singulated
3. Dimensioning and tolerancing per ASME Y14.5M

BSC: Basic Dimension. Theoretically exact value shown without tolerances.

REF: Reference Dimension, usually without tolerance, for information purposes only.

**Footprint Outlines and Dimensions**

**28-Lead Ultra Thin Plastic Quad Flat, No Lead Package (PW) - 4x4x0.6 mm Body [UQFN] With Corner Anchors**

**Note:** For the most current package drawings, please see the Microchip Packaging Specification located at <http://www.microchip.com/packaging>

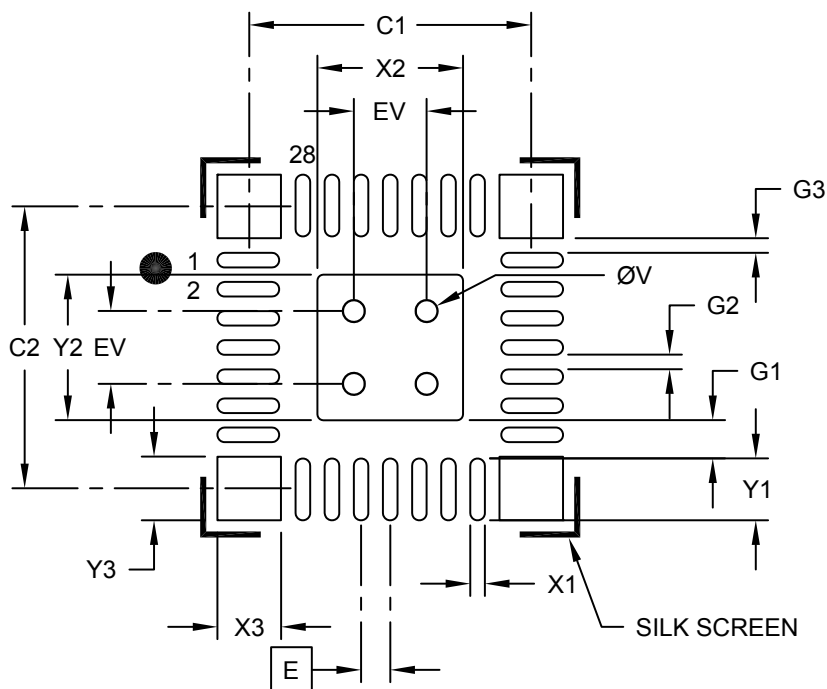

**RECOMMENDED LAND PATTERN**

Dimension	Units	MILLIMETERS		
		MIN	NOM	MAX
Contact Pitch	E	0.40 BSC		
Center Pad Width	X2			2.00
Center Pad Length	Y2			2.00
Contact Pad Spacing	C1		3.90	
Contact Pad Spacing	C2		3.90	
Contact Pad Width (X28)	X1			0.20
Contact Pad Length (X28)	Y1			0.85
Contact Pad to Center Pad (X28)	G1		0.52	
Contact Pad to Pad (X24)	G2	0.20		
Contact Pad to Corner Pad (X8)	G3	0.20		
Corner Anchor Width (X4)	X3			0.78
Corner Anchor Length (X4)	Y3			0.78
Thermal Via Diameter	V		0.30	
Thermal Via Pitch	EV		1.00	

**Notes:**

1. Dimensioning and tolerancing per ASME Y14.5M

BSC: Basic Dimension. Theoretically exact value shown without tolerances.

Microchip Technology Drawing C04-2333-PW Rev B



**Package Outlines and Dimensions**

**28-Lead Ultra Thin Plastic Quad Flat, No Lead Package (M6) - 4x4x0.6 mm Body [UQFN] With Corner Anchors**

**Note:** For the most current package drawings, please see the Microchip Packaging Specification located at <http://www.microchip.com/packaging>

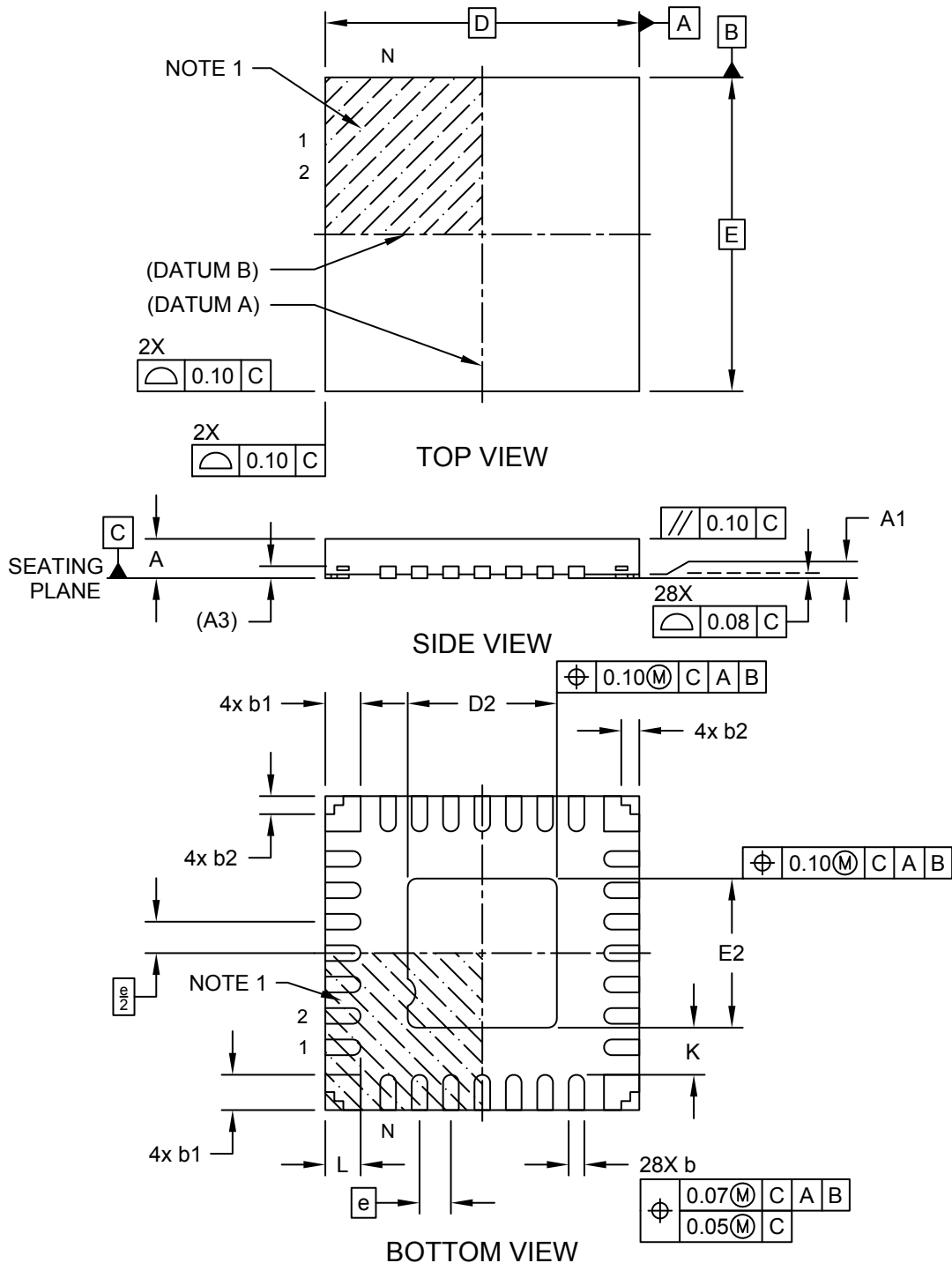

**Package Outlines and Dimensions**

**28-Lead Ultra Thin Plastic Quad Flat, No Lead Package (M6) - 4x4x0.6 mm Body [UQFN] With Corner Anchors**

**Note:** For the most current package drawings, please see the Microchip Packaging Specification located at <http://www.microchip.com/packaging>

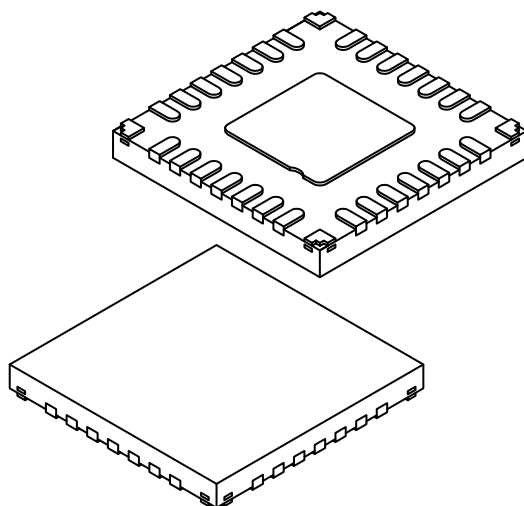

Dimension Limits	Units	MILLIMETERS		
		MIN	NOM	MAX
Number of Pins	N	28		
Pitch	e	0.40 BSC		
Overall Height	A	-	-	0.60
Standoff	A1	0.00	0.02	0.05
Terminal Thickness	A3	0.152 REF		
Overall Width	E	4.00 BSC		
Exposed Pad Width	E2	1.80	1.90	2.00
Overall Length	D	4.00 BSC		
Exposed Pad Length	D2	1.80	1.90	2.00
Terminal Width	b	0.15	0.20	0.25
Corner Anchor Pad	b1	0.40	0.45	0.50
Corner Pad, Metal Free Zone	b2	0.18	0.23	0.28
Terminal Length	L	0.30	0.45	0.50
Terminal-to-Exposed-Pad	K	-	0.60	-

**Notes:**

1. Pin 1 visual index feature may vary, but must be located within the hatched area.
2. Package is saw singulated
3. Dimensioning and tolerancing per ASME Y14.5M

BSC: Basic Dimension. Theoretically exact value shown without tolerances.

REF: Reference Dimension, usually without tolerance, for information purposes only.

---



---

## Footprint Outlines and Dimensions

---



---

### 28-Lead Ultra Thin Plastic Quad Flat, No Lead Package (M6) - 4x4x0.6 mm Body [UQFN] With Corner Anchors

**Note:** For the most current package drawings, please see the Microchip Packaging Specification located at <http://www.microchip.com/packaging>

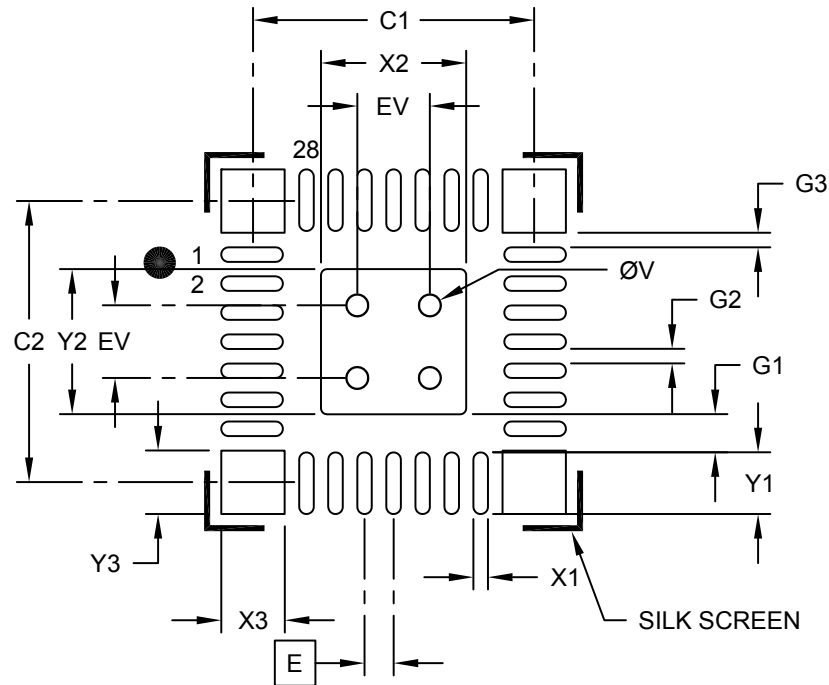

### RECOMMENDED LAND PATTERN

Dimension Limits	Units	MILLIMETERS		
		MIN	NOM	MAX
Contact Pitch	E	0.40 BSC		
Center Pad Width	X2			2.00
Center Pad Length	Y2			2.00
Contact Pad Spacing	C1		3.90	
Contact Pad Spacing	C2		3.90	
Contact Pad Width (X28)	X1			0.20
Contact Pad Length (X28)	Y1			0.85
Contact Pad to Center Pad (X28)	G1		0.52	
Contact Pad to Pad (X24)	G2	0.20		
Contact Pad to Corner Pad (X8)	G3	0.20		
Corner Anchor Width (X4)	X3			0.78
Corner Anchor Length (X4)	Y3			0.78
Thermal Via Diameter	V		0.30	
Thermal Via Pitch	EV		1.00	

Notes:

1. Dimensioning and tolerancing per ASME Y14.5M

BSC: Basic Dimension. Theoretically exact value shown without tolerances.

Microchip Technology Drawing C04-2333-M6 Rev B

**Package Outlines and Dimensions**

**28-Lead Plastic Quad Flat, No Lead Package (MX) - 6x6x0.5mm Body [UQFN]  
Ultra-Thin with 0.40 x 0.60 mm Terminal Width/Length and Corner Anchors**

**Note:** For the most current package drawings, please see the Microchip Packaging Specification located at <http://www.microchip.com/packaging>

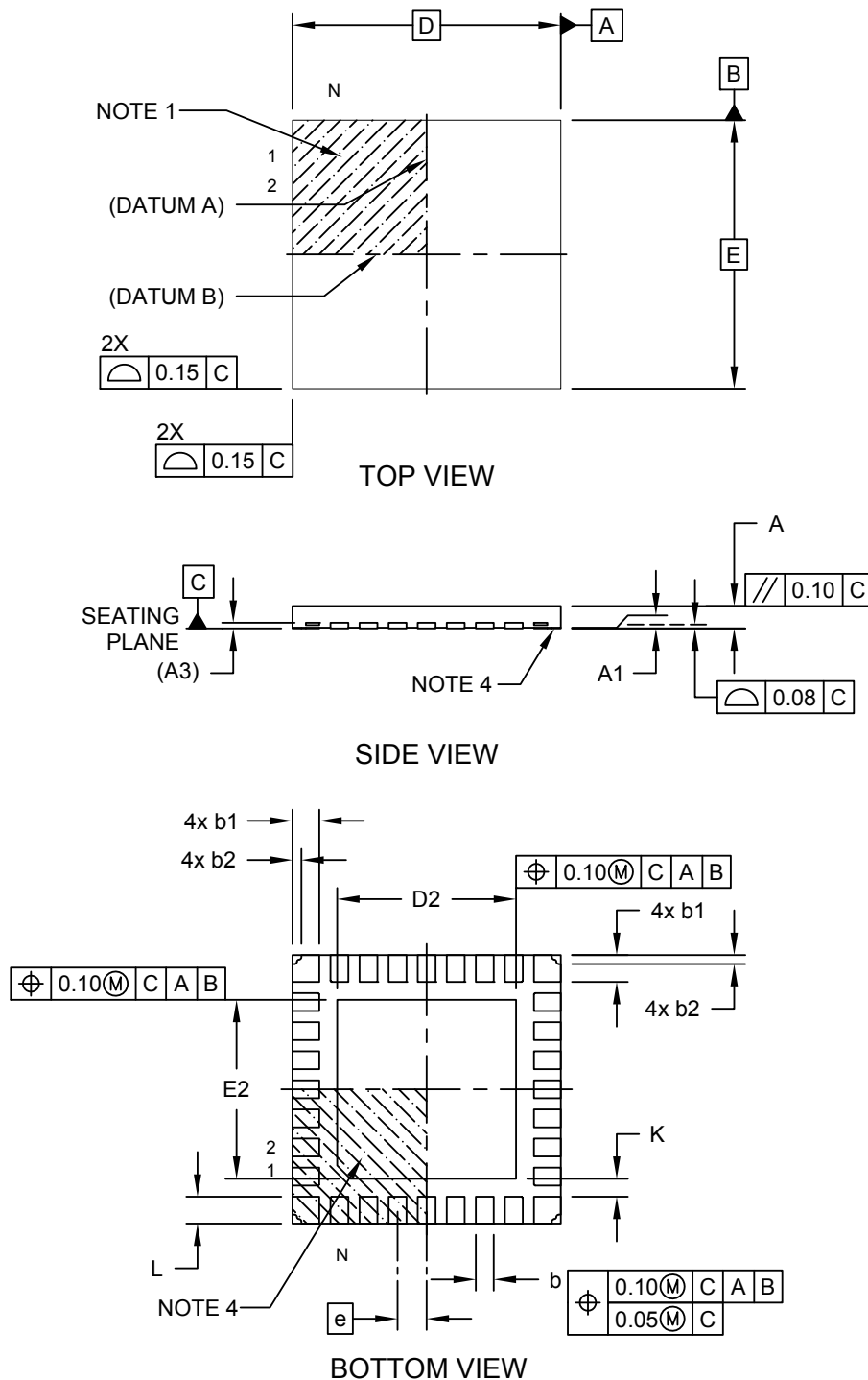

---



---

## Package Outlines and Dimensions

---



---

### 28-Lead Plastic Quad Flat, No Lead Package (MX) - 6x6x0.5mm Body [UQFN] Ultra-Thin with 0.40 x 0.60 mm Terminal Width/Length and Corner Anchors

**Note:** For the most current package drawings, please see the Microchip Packaging Specification located at <http://www.microchip.com/packaging>

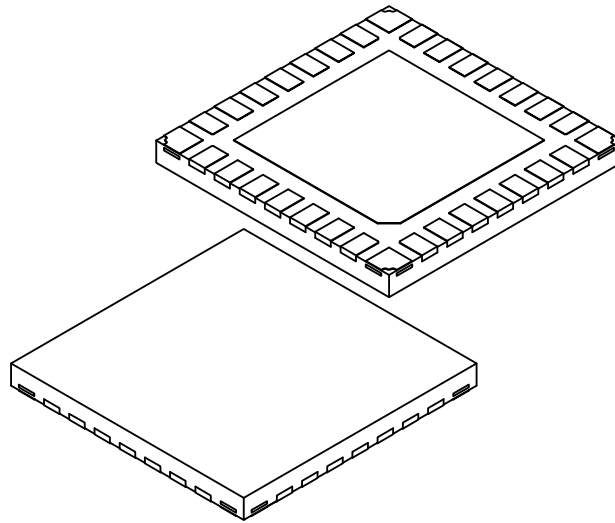

Dimension Limits	Units	MILLIMETERS		
		MIN	NOM	MAX
Number of Pins	N	28		
Pitch	e	0.65 BSC		
Overall Height	A	0.40	0.50	0.60
Standoff	A1	0.00	0.02	0.05
Terminal Thickness	(A3)	0.127 REF		
Overall Width	E	6.00 BSC		
Exposed Pad Width	E2		4.00	
Overall Length	D	6.00 BSC		
Exposed Pad Length	D2		4.00	
Terminal Width	b	0.35	0.40	0.45
Corner Pad	b1	0.55	0.60	0.65
Corner Pad, Metal Free Zone	b2	0.15	0.20	0.25
Terminal Length	L	0.55	0.60	0.65
Terminal-to-Exposed Pad	K	0.20	-	-

**Notes:**

1. Pin 1 visual index feature may vary, but must be located within the hatched area.
2. Package is saw singulated
3. Dimensioning and tolerancing per ASME Y14.5M
  - BSC: Basic Dimension. Theoretically exact value shown without tolerances.
  - REF: Reference Dimension, usually without tolerance, for information purposes only.
4. Outermost portions of corner structures may vary slightly.

**Footprint Outlines and Dimensions**

**28-Lead Plastic Quad Flat, No Lead Package (MX) - 6x6 mm Body [UQFN]  
With 0.60mm Contact Length And Corner Anchors**

**Note:** For the most current package drawings, please see the Microchip Packaging Specification located at <http://www.microchip.com/packaging>

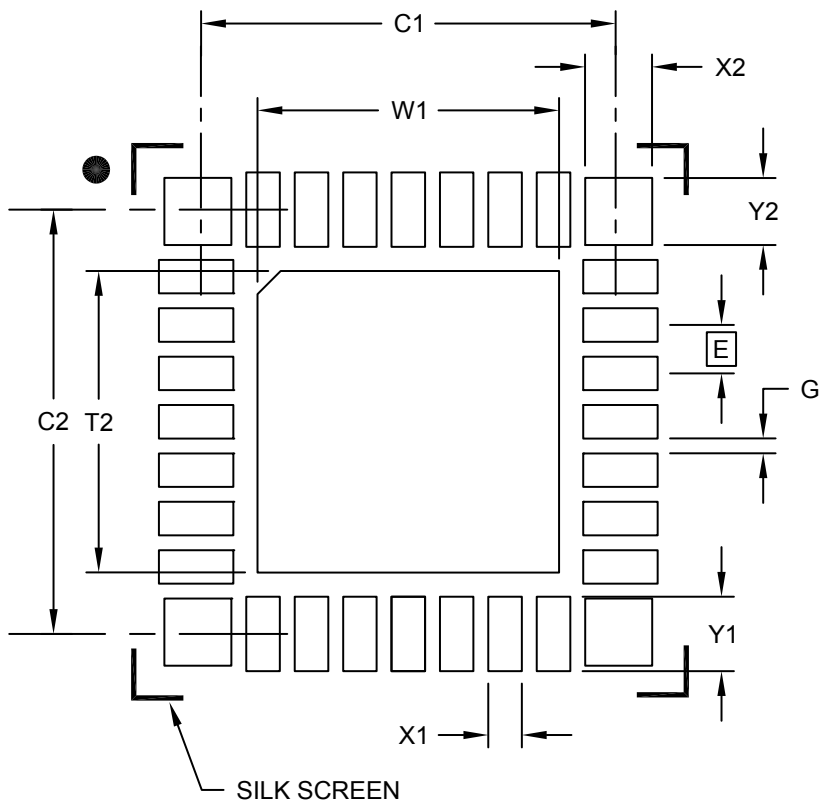

**RECOMMENDED LAND PATTERN**

Dimension Limits	Units	MILLIMETERS		
		MIN	NOM	MAX
Contact Pitch	E	0.65 BSC		
Optional Center Pad Width	W1			4.05
Optional Center Pad Length	T2			4.05
Contact Pad Spacing	C1		5.70	
Contact Pad Spacing	C2		5.70	
Contact Pad Width (X28)	X1			0.45
Contact Pad Length (X28)	Y1			1.00
Corner Pad Width (X4)	X2			0.90
Corner Pad Length (X4)	Y2			0.90
Distance Between Pads	G	0.20		

**Notes:**

1. Dimensioning and tolerancing per ASME Y14.5M

BSC: Basic Dimension. Theoretically exact value shown without tolerances.

**Package Outlines and Dimensions**

**28-Lead Ultra Thin Plastic Quad Flat, No Lead Package (2N) - 6x6x0.55 mm Body [UQFN] With 4.65x4.65 mm Exposed Pad and Corner Anchors**

**Note:** For the most current package drawings, please see the Microchip Packaging Specification located at <http://www.microchip.com/packaging>

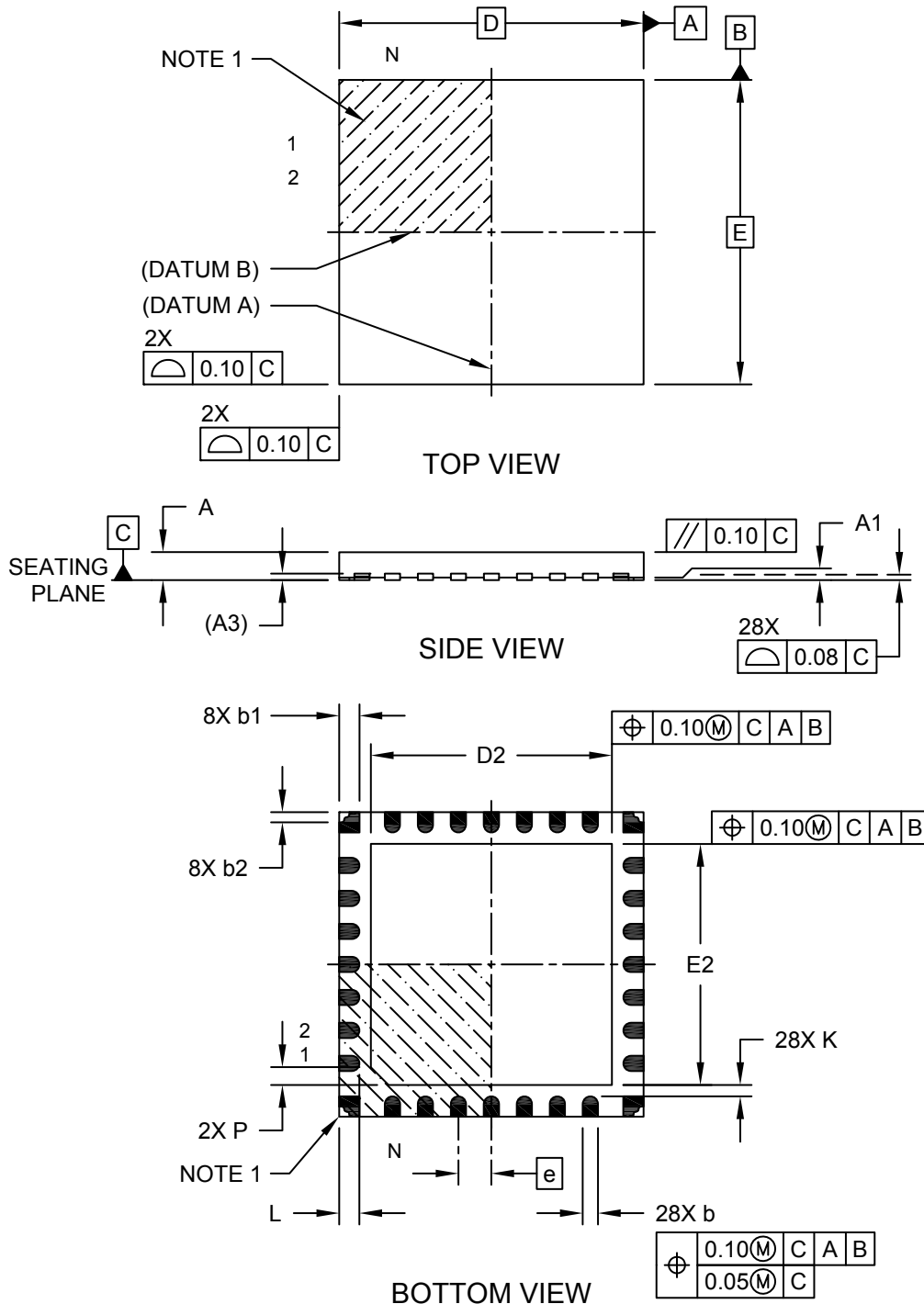

Microchip Technology Drawing C04-385B Sheet 1 of 2

**Package Outlines and Dimensions**

**28-Lead Ultra Thin Plastic Quad Flat, No Lead Package (2N) - 6x6x0.55 mm Body [UQFN]  
With 4.65x4.65 mm Exposed Pad and Corner Anchors**

**Note:** For the most current package drawings, please see the Microchip Packaging Specification located at <http://www.microchip.com/packaging>

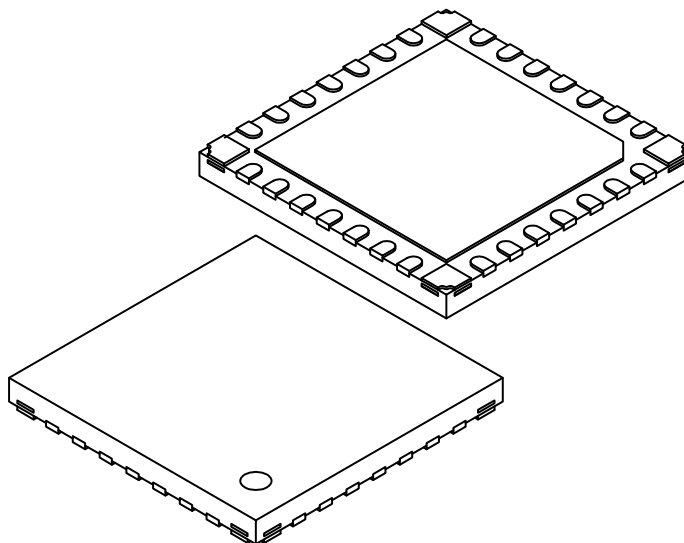

Dimension Limits		Units	MILLIMETERS		
			MIN	NOM	MAX
Number of Terminals	N		28		
Pitch	e		0.65 BSC		
Overall Height	A	0.45	0.50	0.55	
Standoff	A1	0.00	0.02	0.05	
Terminal Thickness	A3	0.127 REF			
Overall Width	E	6.00 BSC			
Exposed Pad Width	E2	4.55	4.65	4.75	
Overall Length	D	6.00 BSC			
Exposed Pad Length	D2	4.55	4.65	4.75	
Exposed Pad Corner Chamfer	P	-	0.35	-	
Terminal Width	b	0.25	0.30	0.35	
Corner Anchor Pad	b1	0.35	0.40	0.43	
Corner Pad, Metal Free Zone	b2	0.15	0.20	0.25	
Terminal Length	L	0.30	0.40	0.50	
Terminal-to-Exposed-Pad	K	0.20	-	-	

**Notes:**

1. Pin 1 visual index feature may vary, but must be located within the hatched area.
2. Package is saw singulated
3. Dimensioning and tolerancing per ASME Y14.5M

BSC: Basic Dimension. Theoretically exact value shown without tolerances.

REF: Reference Dimension, usually without tolerance, for information purposes only.



---



---

## Footprint Outlines and Dimensions

---



---

### 28-Lead Ultra Thin Plastic Quad Flat, No Lead Package (2N) - 6x6x0.55 mm Body [UQFN] With 4.65x4.65 mm Exposed Pad and Corner Anchors

**Note:** For the most current package drawings, please see the Microchip Packaging Specification located at <http://www.microchip.com/packaging>

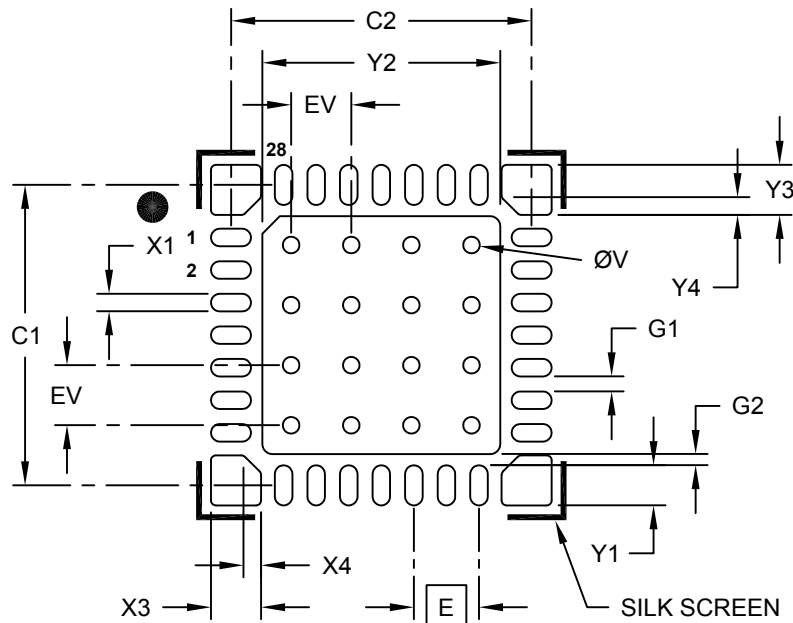

**RECOMMENDED LAND PATTERN**

Dimension Limits	Units	MILLIMETERS		
		MIN	NOM	MAX
Contact Pitch	E	0.65 BSC		
Optional Center Pad Width	X2			4.75
Optional Center Pad Length	Y2			4.75
Contact Pad Spacing	C1		6.00	
Contact Pad Spacing	C2		6.00	
Contact Pad Width (X28)	X1			0.35
Contact Pad Length (X28)	Y1			0.80
Corner Anchor (X4)	X3			1.00
Corner Anchor (X4)	Y3			1.00
Corner Anchor Chamfer (X4)	X4			0.35
Corner Anchor Chamfer (X4)	Y4			0.35
Contact Pad to Pad (X28)	G1	0.20		
Contact Pad to Center Pad (X28)	G2	0.20		
Thermal Via Diameter	V		0.33	
Thermal Via Pitch	EV		1.20	

**Notes:**

1. Dimensioning and tolerancing per ASME Y14.5M  
BSC: Basic Dimension. Theoretically exact value shown without tolerances.
2. For best soldering results, thermal vias, if used, should be filled or tented to avoid solder loss during reflow process

Microchip Technology Drawing C04-2385B

**Package Outlines and Dimensions**

**36-Lead Ultra Thin Plastic Quad Flat, No Lead Package (M5) - 5x5 mm Body [UQFN] With Corner Anchors**

**Note:** For the most current package drawings, please see the Microchip Packaging Specification located at <http://www.microchip.com/packaging>

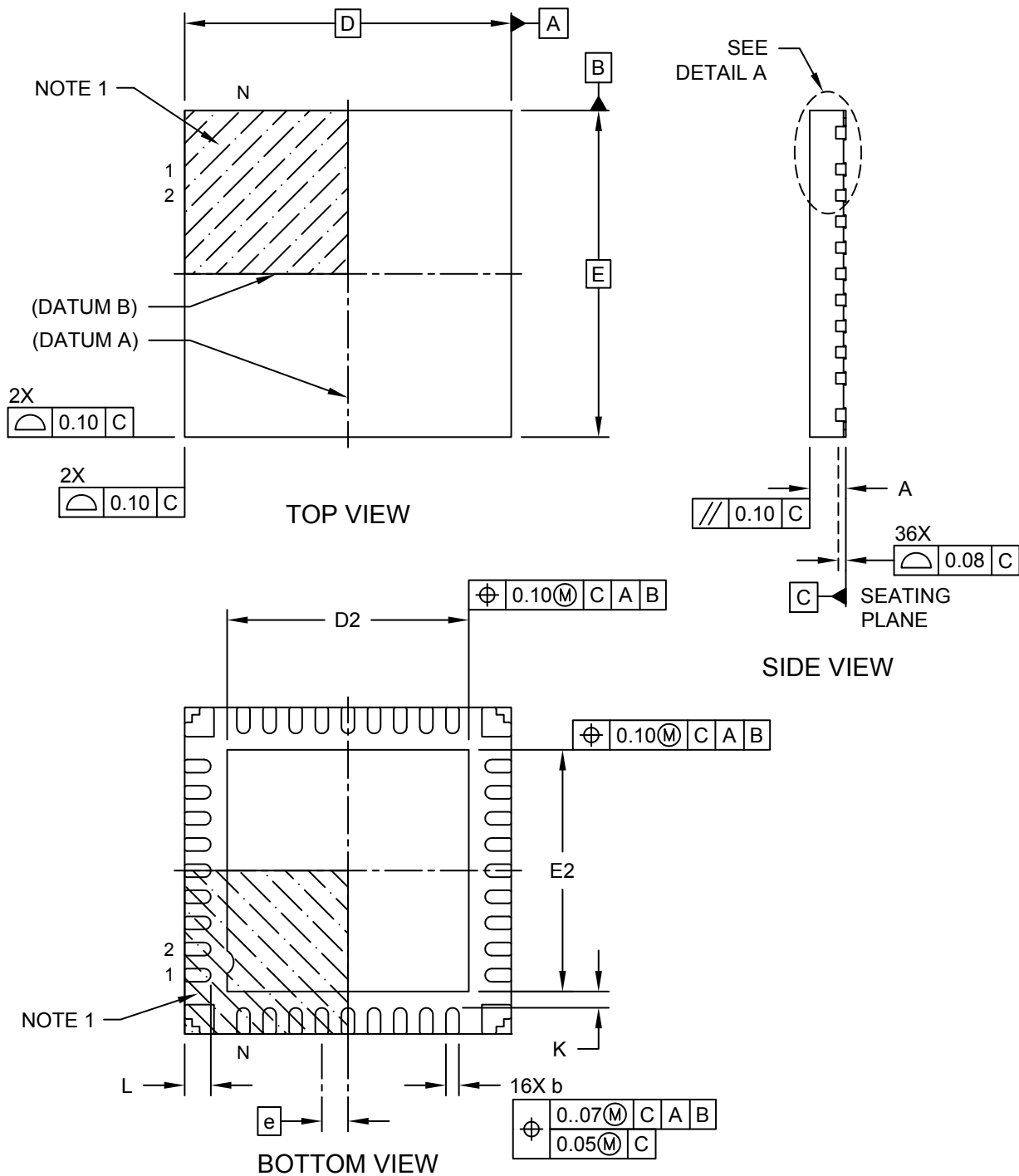

---



---

## Package Outlines and Dimensions

---



---

### 36-Lead Ultra Thin Plastic Quad Flat, No Lead Package (M5) - 5x5 mm Body [UQFN] With Corner Anchors

**Note:** For the most current package drawings, please see the Microchip Packaging Specification located at <http://www.microchip.com/packaging>

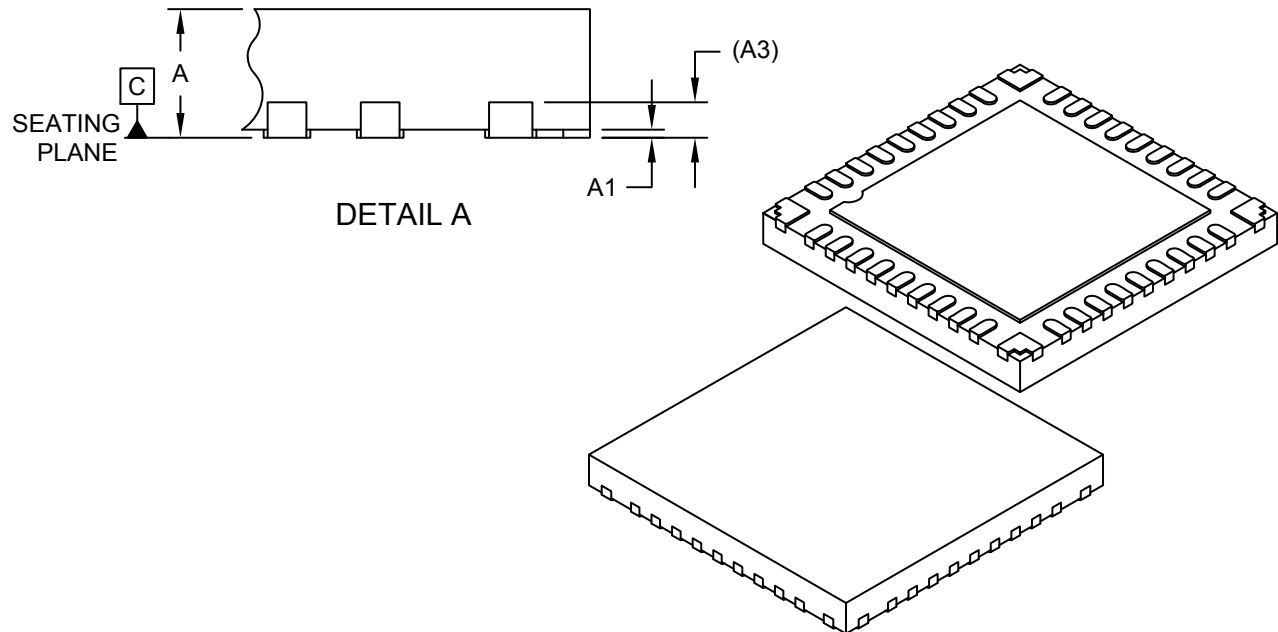

Dimension Limits	Units	MILLIMETERS		
		MIN	NOM	MAX
Number of Terminals	N	36		
Pitch	e	0.40 BSC		
Overall Height	A	0.50	0.55	0.60
Standoff	A1	0.00	0.02	0.05
Terminal Thickness	A3	0.152 REF		
Overall Length	D	5.00 BSC		
Exposed Pad Length	D2	3.60	3.70	3.80
Overall Width	E	5.00 BSC		
Exposed Pad Width	E2	3.60	3.70	3.80
Terminal Width	b	0.15	0.20	0.25
Terminal Length	L	0.30	0.40	0.50
Terminal-to-Exposed-Pad	K	0.25 REF		

**Notes:**

1. Pin 1 visual index feature may vary, but must be located within the hatched area.
2. Package is saw singulated
3. Dimensioning and tolerancing per ASME Y14.5M
  - BSC: Basic Dimension. Theoretically exact value shown without tolerances.
  - REF: Reference Dimension, usually without tolerance, for information purposes only.

**Footprint Outlines and Dimensions**

**36-Lead Ultra Thin Plastic Quad Flat, No Lead Package (M5) - 5x5 mm Body [UQFN] With Corner Anchors**

**Note:** For the most current package drawings, please see the Microchip Packaging Specification located at <http://www.microchip.com/packaging>

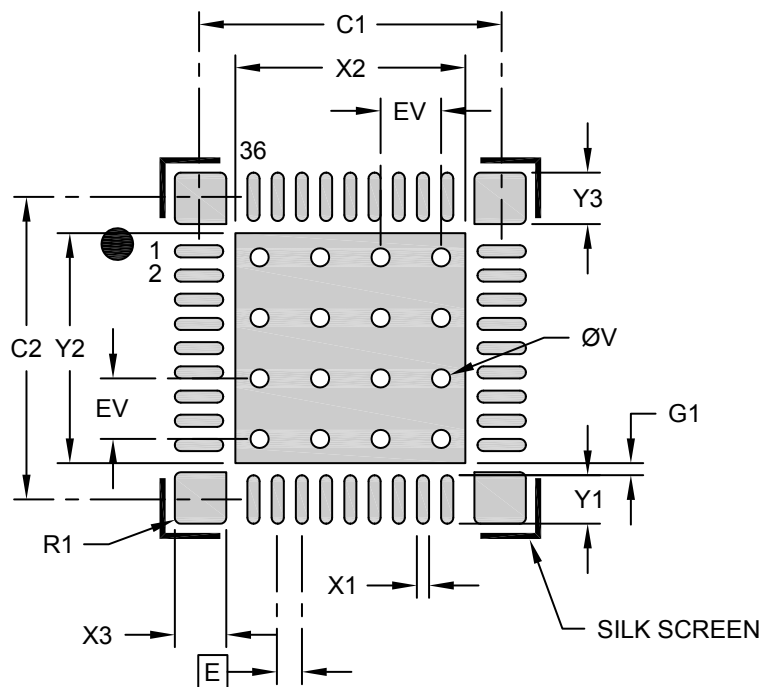

**RECOMMENDED LAND PATTERN**

Dimension Limits	Units	MILLIMETERS		
		MIN	NOM	MAX
Contact Pitch	E	0.40 BSC		
Optional Center Pad Width	X2			3.80
Optional Center Pad Length	Y2			3.80
Contact Pad Spacing	C1		5.00	
Contact Pad Spacing	C2		5.00	
Contact Pad Width (X36)	X1			0.20
Contact Pad Length (X36)	Y1			0.80
Corner Pad Width (X4)	X3			0.20
Corner Pad Length (X36)	Y3			0.85
Corner Pad Radius	R1		0.10	
Contact Pad to Center Pad (X36)	G1	0.20		
Thermal Via Diameter	V		0.30	
Thermal Via Pitch	EV		1.00	

**Notes:**

- Dimensioning and tolerancing per ASME Y14.5M  
BSC: Basic Dimension. Theoretically exact value shown without tolerances.
- For best soldering results, thermal vias, if used, should be filled or tented to avoid solder loss during reflow process

**Package Outlines and Dimensions**

**36-Lead Ultra Thin Plastic Quad Flat, No Lead Package (SCX) - 5x5 mm Body [UQFN] With Corner Anchors**

**Note:** For the most current package drawings, please see the Microchip Packaging Specification located at <http://www.microchip.com/packaging>

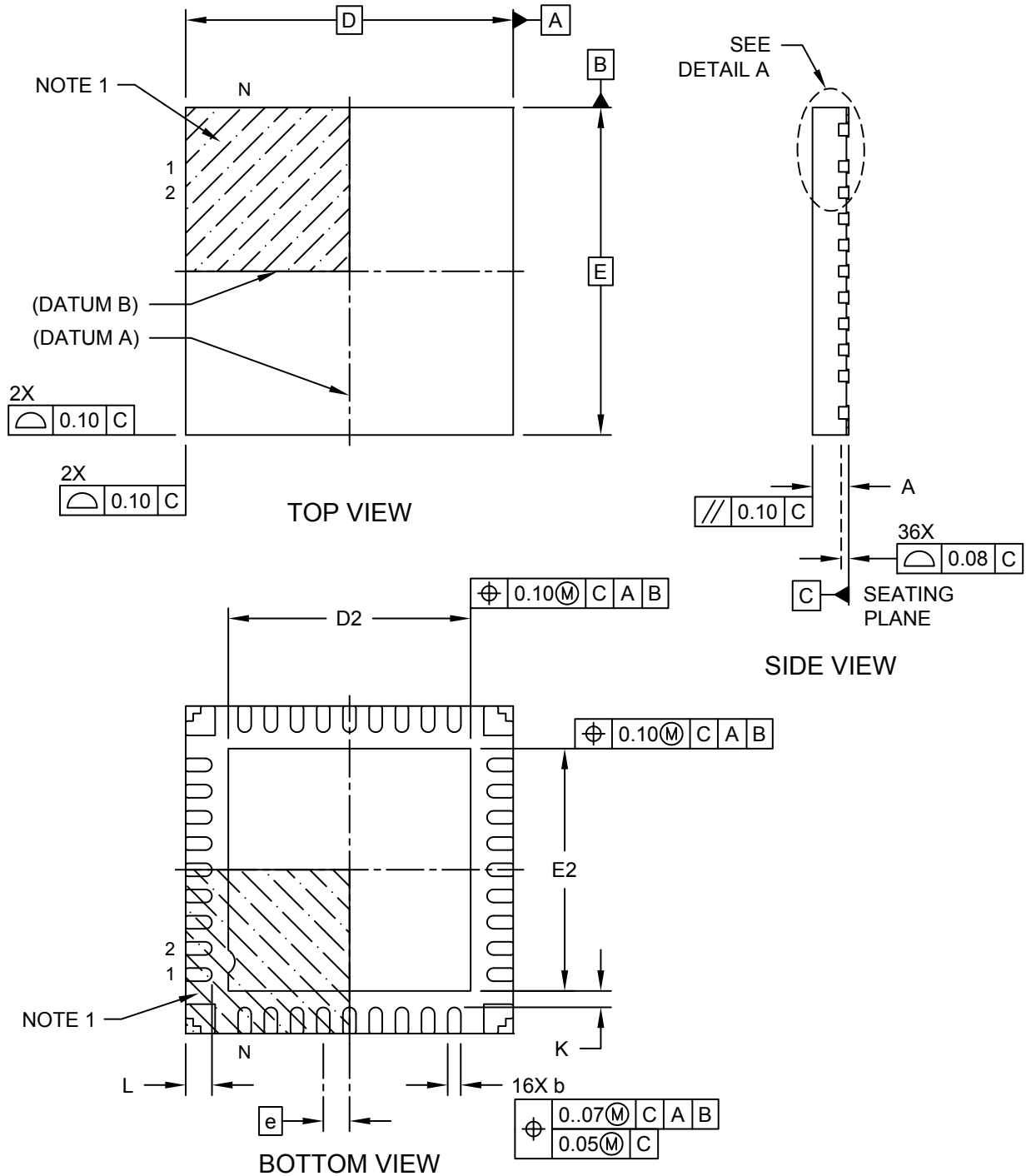

**Package Outlines and Dimensions**

**36-Lead Ultra Thin Plastic Quad Flat, No Lead Package (SCX) - 5x5 mm Body [UQFN] With Corner Anchors**

**Note:** For the most current package drawings, please see the Microchip Packaging Specification located at <http://www.microchip.com/packaging>

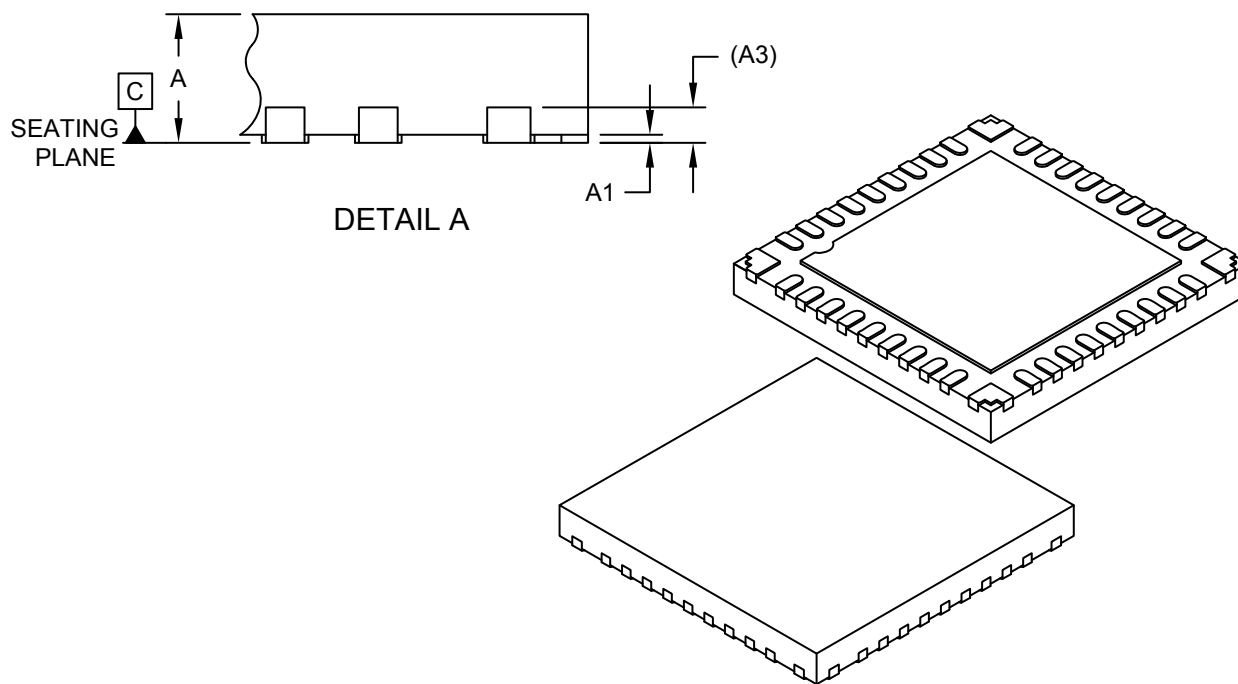

Dimension Limits	Units	MILLIMETERS		
		MIN	NOM	MAX
Number of Terminals	N	36		
Pitch	e	0.40 BSC		
Overall Height	A	0.50	0.55	0.60
Standoff	A1	0.00	0.02	0.05
Terminal Thickness	A3	0.152 REF		
Overall Length	D	5.00 BSC		
Exposed Pad Length	D2	3.60	3.70	3.80
Overall Width	E	5.00 BSC		
Exposed Pad Width	E2	3.60	3.70	3.80
Terminal Width	b	0.15	0.20	0.25
Terminal Length	L	0.30	0.40	0.50
Terminal-to-Exposed-Pad	K	0.25 REF		

**Notes:**

1. Pin 1 visual index feature may vary, but must be located within the hatched area.
2. Package is saw singulated
3. Dimensioning and tolerancing per ASME Y14.5M

BSC: Basic Dimension. Theoretically exact value shown without tolerances.

REF: Reference Dimension, usually without tolerance, for information purposes only.

---



---

## Footprint Outlines and Dimensions

---



---

### 36-Lead Ultra Thin Plastic Quad Flat, No Lead Package (SCX) - 5x5 mm Body [UQFN] With Corner Anchors

**Note:** For the most current package drawings, please see the Microchip Packaging Specification located at <http://www.microchip.com/packaging>

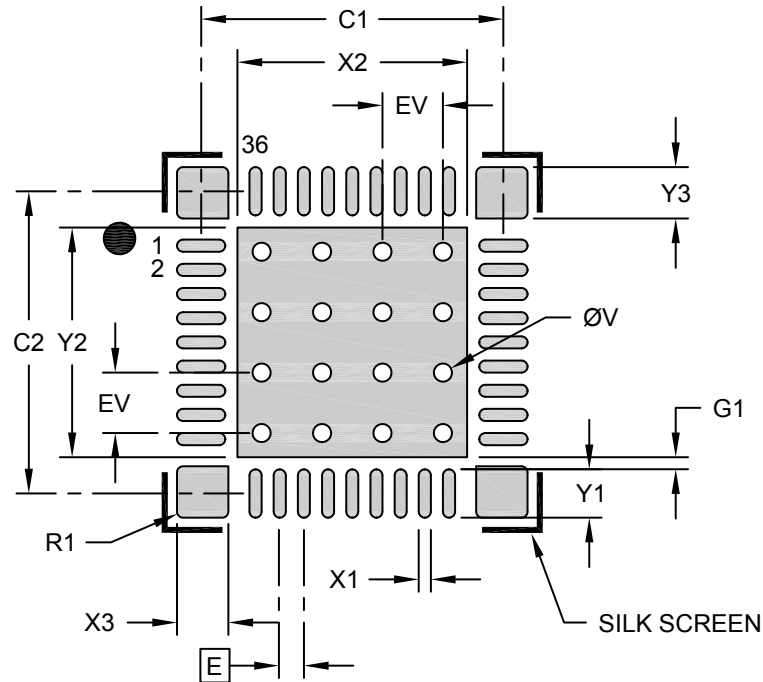

**RECOMMENDED LAND PATTERN**

Dimension Limits	Units	MILLIMETERS		
		MIN	NOM	MAX
Contact Pitch	E	0.40 BSC		
Optional Center Pad Width	X2			3.80
Optional Center Pad Length	Y2			3.80
Contact Pad Spacing	C1		5.00	
Contact Pad Spacing	C2		5.00	
Contact Pad Width (X36)	X1			0.20
Contact Pad Length (X36)	Y1			0.80
Corner Pad Width (X4)	X3			0.20
Corner Pad Length (X36)	Y3			0.85
Corner Pad Radius	R1		0.10	
Contact Pad to Center Pad (X36)	G1	0.20		
Thermal Via Diameter	V		0.30	
Thermal Via Pitch	EV		1.00	

**Notes:**

1. Dimensioning and tolerancing per ASME Y14.5M  
BSC: Basic Dimension. Theoretically exact value shown without tolerances.
2. For best soldering results, thermal vias, if used, should be filled or tented to avoid solder loss during reflow process

**Package Outlines and Dimensions**

**40-Lead Ultra Thin Plastic Quad Flat, No Lead Package (MV) – 5x5x0.5 mm Body [UQFN]**

**Note:** For the most current package drawings, please see the Microchip Packaging Specification located at <http://www.microchip.com/packaging>

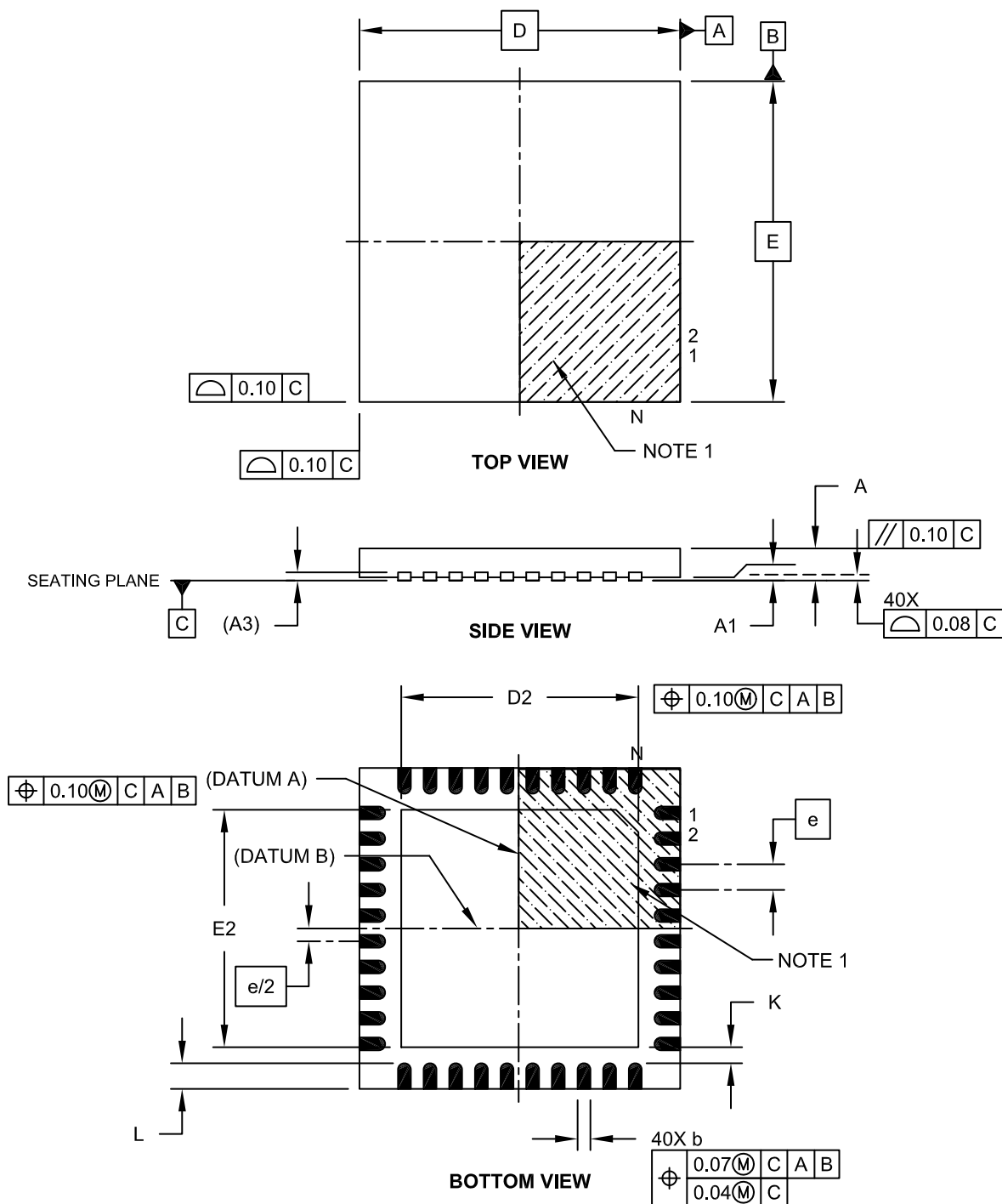



---



---

## Package Outlines and Dimensions

---



---

### 40-Lead Ultra Thin Plastic Quad Flat, No Lead Package (MV) – 5x5x0.5 mm Body [UQFN]

**Note:** For the most current package drawings, please see the Microchip Packaging Specification located at <http://www.microchip.com/packaging>

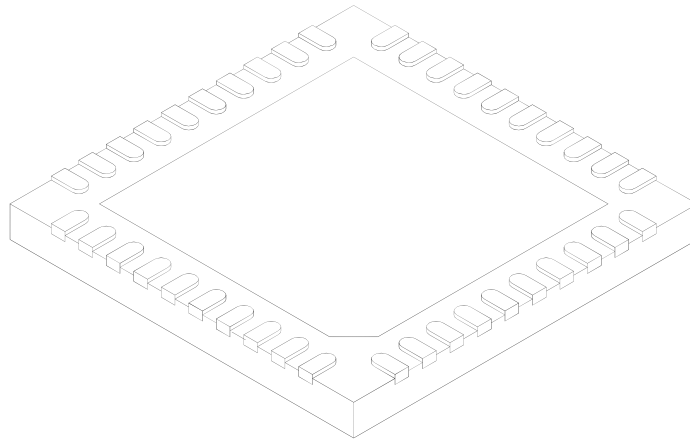

Dimension Limits	Units	MILLIMETERS		
		MIN	NOM	MAX
Number of Pins	N	40		
Pitch	e	0.40 BSC		
Overall Height	A	0.45	0.50	0.55
Standoff	A1	0.00	0.02	0.05
Contact Thickness	A3	0.127 REF		
Overall Width	E	5.00 BSC		
Exposed Pad Width	E2	3.60	3.70	3.80
Overall Length	D	5.00 BSC		
Exposed Pad Length	D2	3.60	3.70	3.80
Contact Width	b	0.15	0.20	0.25
Contact Length	L	0.30	0.40	0.50
Contact-to-Exposed Pad	K	0.20	-	-

**Notes:**

1. Pin 1 visual index feature may vary, but must be located within the hatched area.
2. Package is saw singulated.
3. Dimensioning and tolerancing per ASME Y14.5M.
  - BSC: Basic Dimension. Theoretically exact value shown without tolerances.
  - REF: Reference Dimension, usually without tolerance, for information purposes only.

**Footprint Outlines and Dimensions**

**40-Lead Plastic Ultra Thin Quad Flat, No Lead Package (MV) - 5x5 mm Body [UQFN]**

**Note:** For the most current package drawings, please see the Microchip Packaging Specification located at <http://www.microchip.com/packaging>

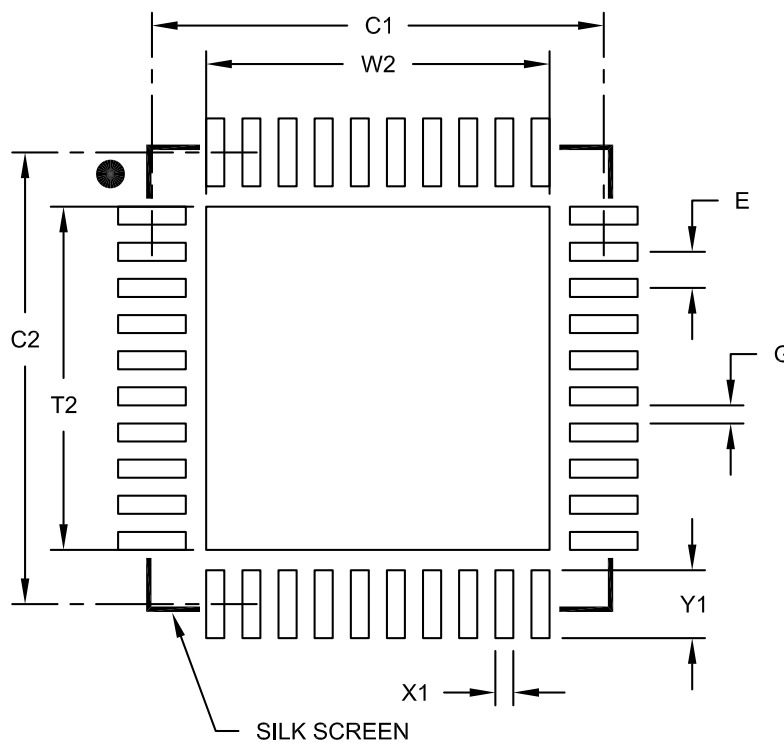

**RECOMMENDED LAND PATTERN**

Dimension Limits	Units	MILLIMETERS		
		MIN	NOM	MAX
Contact Pitch	E	0.40 BSC		
Optional Center Pad Width	W2			3.80
Optional Center Pad Length	T2			3.80
Contact Pad Spacing	C1		5.00	
Contact Pad Spacing	C2		5.00	
Contact Pad Width (X40)	X1			0.20
Contact Pad Length (X40)	Y1			0.75
Distance Between Pads	G	0.20		

**Notes:**

1. Dimensioning and tolerancing per ASME Y14.5M

BSC: Basic Dimension. Theoretically exact value shown without tolerances.

Microchip Technology Drawing No. C04-2156B

**Package Outlines and Dimensions**

**48-Lead Plastic Ultra Thin Quad Flat, No Lead Package (MV) – 6x6x0.5 mm Body [UQFN]**

**Note:** For the most current package drawings, please see the Microchip Packaging Specification located at <http://www.microchip.com/packaging>

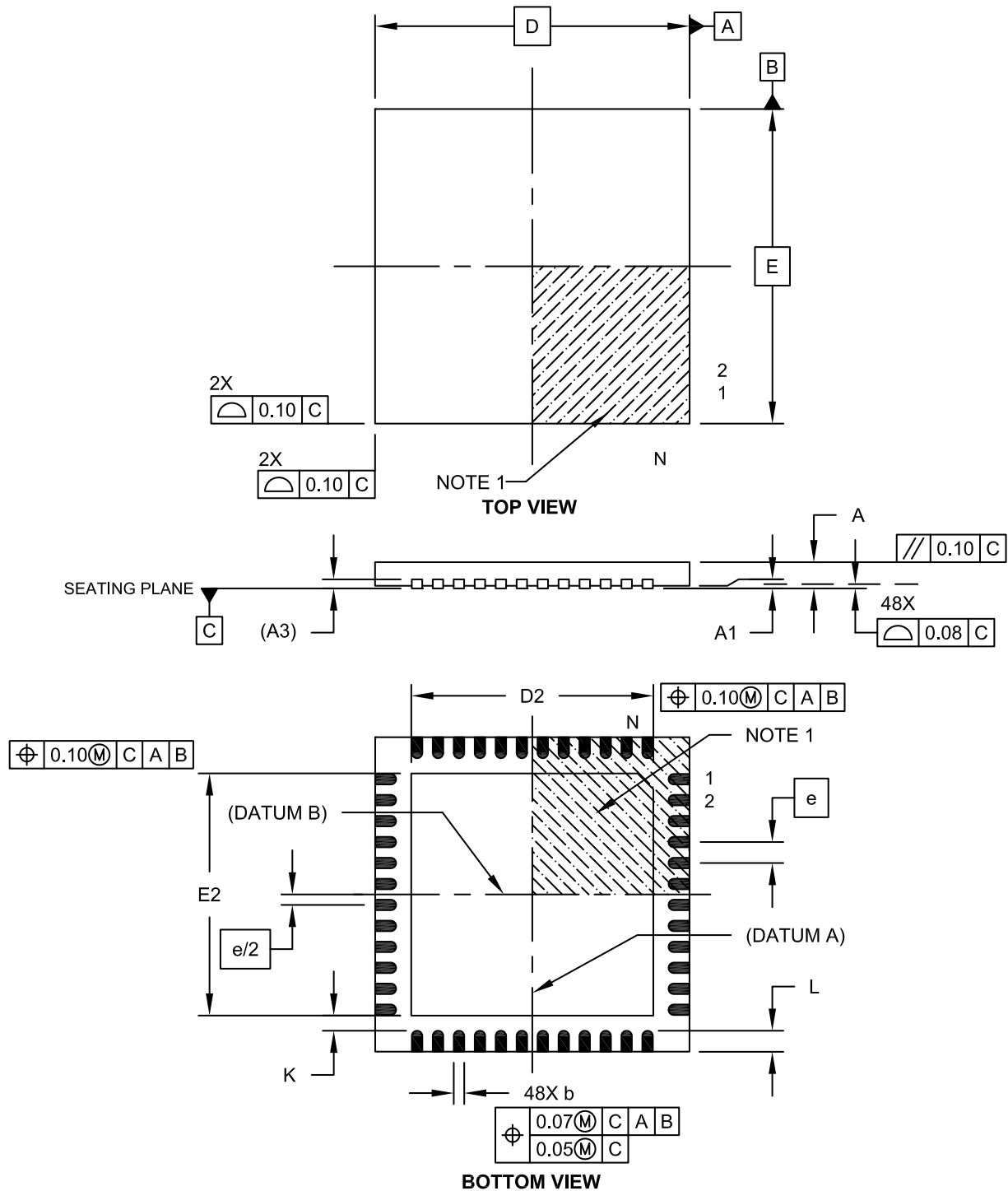

**Package Outlines and Dimensions**

**48-Lead Plastic Ultra Thin Quad Flat, No Lead Package (MV) – 6x6x0.5 mm Body [UQFN]**

**Note:** For the most current package drawings, please see the Microchip Packaging Specification located at <http://www.microchip.com/packaging>

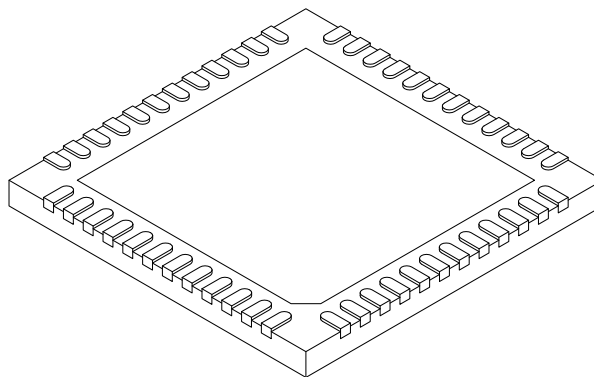

		Units	MILLIMETERS		
Dimension Limits			MIN	NOM	MAX
Number of Pins	N		48		
Pitch	e		0.40 BSC		
Overall Height	A	0.45	0.50	0.55	
Standoff	A1	0.00	0.02	0.05	
Contact Thickness	A3	0.127 REF			
Overall Width	E	6.00 BSC			
Exposed Pad Width	E2	4.45	4.60	4.75	
Overall Length	D	6.00 BSC			
Exposed Pad Length	D2	4.45	4.60	4.75	
Contact Width	b	0.15	0.20	0.25	
Contact Length	L	0.30	0.40	0.50	
Contact-to-Exposed Pad	K	0.20	-	-	

**Notes:**

- Pin 1 visual index feature may vary, but must be located within the hatched area.
- Package is saw singulated.
- Dimensioning and tolerancing per ASME Y14.5M.
  - BSC: Basic Dimension. Theoretically exact value shown without tolerances.
  - REF: Reference Dimension, usually without tolerance, for information purposes only.

---



---

## Footprint Outlines and Dimensions

---



---

48-Lead Ultra Thin Plastic Quad Flat, No Lead Package (MV) - 6x6 mm Body [UQFN]  
 With 0.40 mm Contact Length

**Note:** For the most current package drawings, please see the Microchip Packaging Specification located at <http://www.microchip.com/packaging>

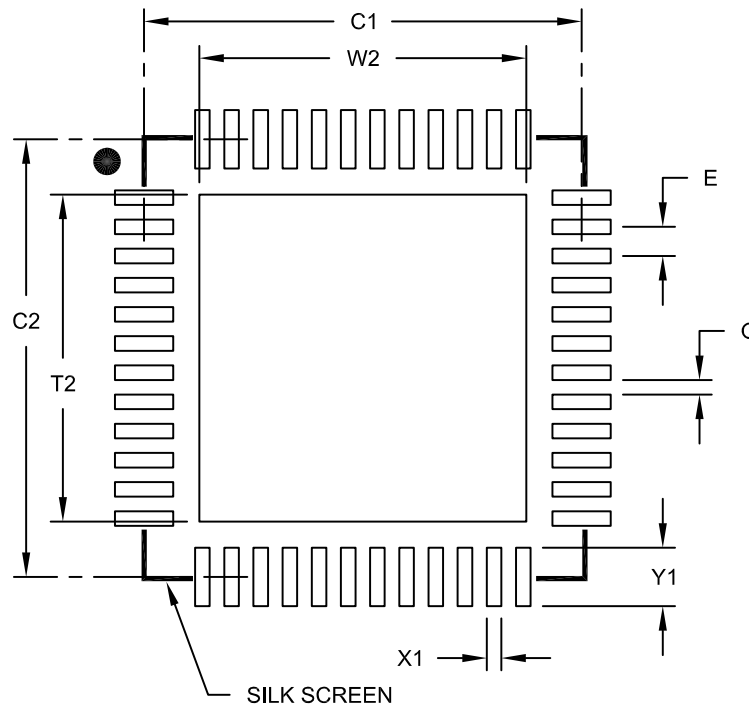

**RECOMMENDED LAND PATTERN**

		MILLIMETERS		
Units				
Dimension Limits		MIN	NOM	MAX
Contact Pitch	E	0.40 BSC		
Optional Center Pad Width	W2			4.45
Optional Center Pad Length	T2			4.45
Contact Pad Spacing	C1		6.00	
Contact Pad Spacing	C2		6.00	
Contact Pad Width (X28)	X1			0.20
Contact Pad Length (X28)	Y1			0.80
Distance Between Pads	G	0.20		

Notes:

1. Dimensioning and tolerancing per ASME Y14.5M

BSC: Basic Dimension. Theoretically exact value shown without tolerances.

Microchip Technology Drawing No. C04-2153A

**Package Outlines and Dimensions**

**48-Lead Ultra Thin Plastic Quad Flat, No Lead Package (M4) - 6x6 mm Body [UQFN] With Corner Anchors and 4.6x4.6 mm Exposed Pad**

**Note:** For the most current package drawings, please see the Microchip Packaging Specification located at <http://www.microchip.com/packaging>

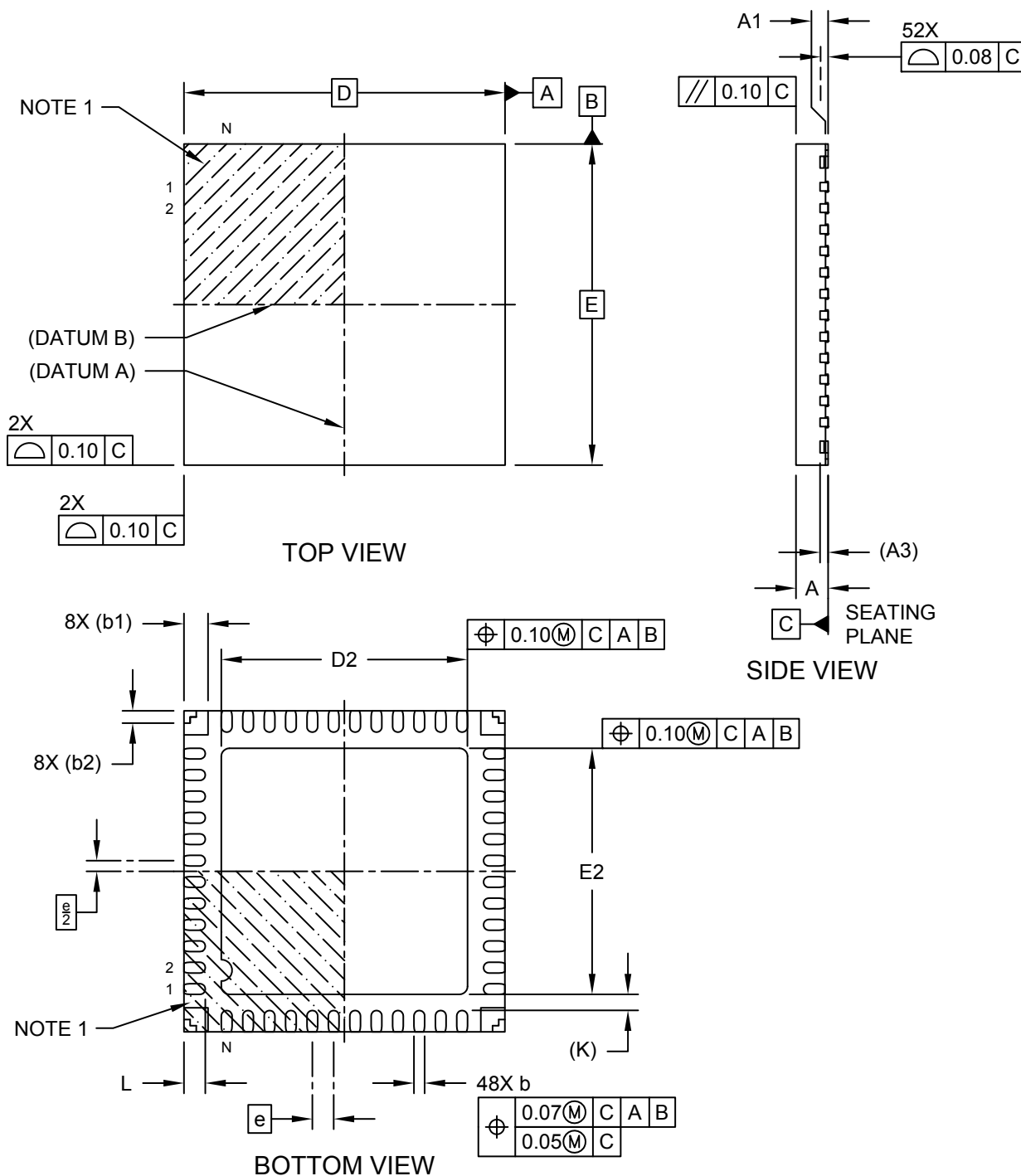

---



---

## Package Outlines and Dimensions

---



---

### 48-Lead Ultra Thin Plastic Quad Flat, No Lead Package (M4) - 6x6 mm Body [UQFN] With Corner Anchors and 4.6x4.6 mm Exposed Pad

**Note:** For the most current package drawings, please see the Microchip Packaging Specification located at <http://www.microchip.com/packaging>

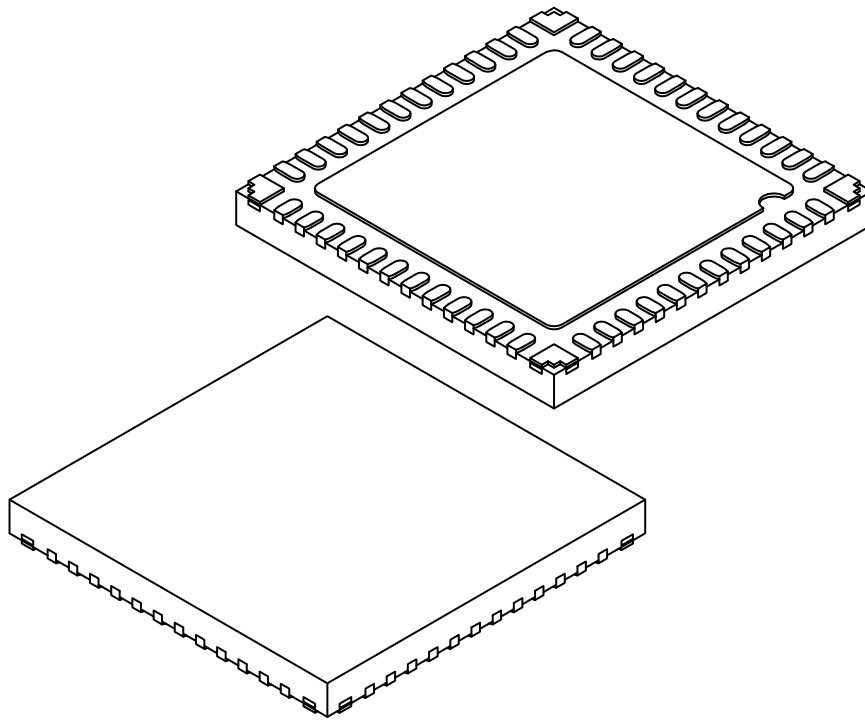

Dimension Limits	Units	MILLIMETERS		
		MIN	NOM	MAX
Number of Terminals	N	48		
Pitch	e	0.40 BSC		
Overall Height	A	0.50	0.55	0.60
Standoff	A1	0.00	0.02	0.05
Terminal Thickness	A3	0.15 REF		
Overall Length	D	6.00 BSC		
Exposed Pad Length	D2	4.50	4.60	4.70
Overall Width	E	6.00 BSC		
Exposed Pad Width	E2	4.50	4.60	4.70
Terminal Width	b	0.15	0.20	0.25
Corner Anchor Pad	b1	0.45 REF		
Corner Anchor Pad, Metal-free Zone	b2	0.23 REF		
Terminal Length	L	0.35	0.40	0.45
Terminal-to-Exposed-Pad	K	0.30 REF		

**Notes:**

1. Pin 1 visual index feature may vary, but must be located within the hatched area.
2. Package is saw singulated
3. Dimensioning and tolerancing per ASME Y14.5M

BSC: Basic Dimension. Theoretically exact value shown without tolerances.

REF: Reference Dimension, usually without tolerance, for information purposes only.

**Footprint Outlines and Dimensions**

**48-Lead Ultra Thin Plastic Quad Flat, No Lead Package (M4) - 6x6 mm Body [UQFN]  
With Corner Anchors and 4.6x4.6 mm Exposed Pad**

**Note:** For the most current package drawings, please see the Microchip Packaging Specification located at <http://www.microchip.com/packaging>

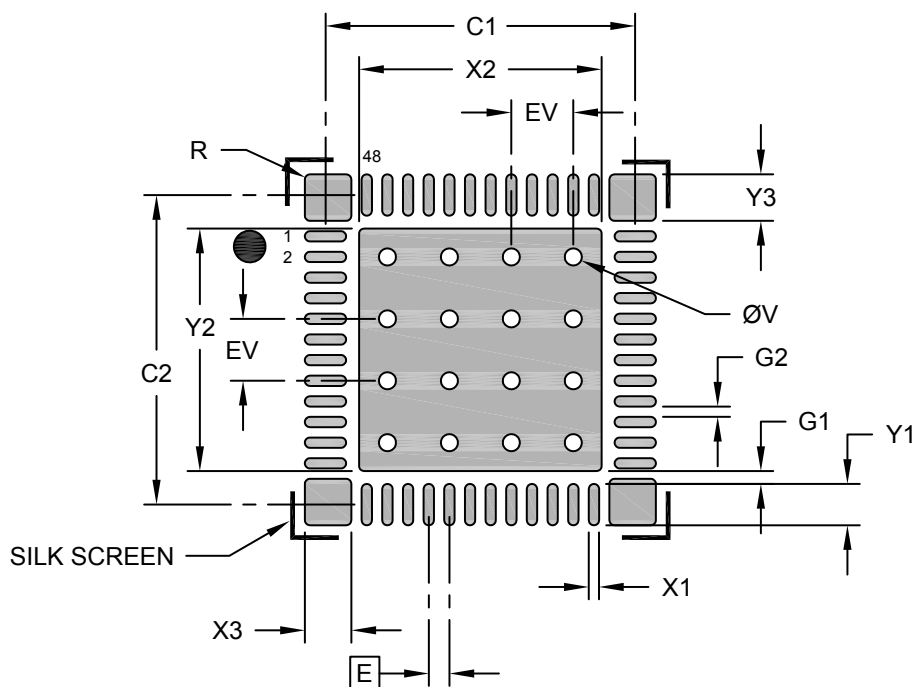

**RECOMMENDED LAND PATTERN**

Dimension Limits	Units	MILLIMETERS		
		MIN	NOM	MAX
Contact Pitch	E	0.40 BSC		
Center Pad Width	X2			4.70
Center Pad Length	Y2			4.70
Contact Pad Spacing	C1		6.00	
Contact Pad Spacing	C2		6.00	
Contact Pad Width (X48)	X1			0.20
Contact Pad Length (X48)	Y1			0.80
Corner Anchor Pad Width (X4)	X3			0.90
Corner Anchor Pad Length (X4)	Y3			0.90
Pad Corner Radius (X 20)	R			0.10
Contact Pad to Center Pad (X48)	G1	0.25		
Contact Pad to Contact Pad	G2	0.20		
Thermal Via Diameter	V		0.33	
Thermal Via Pitch	EV		1.20	

**Notes:**

1. Dimensioning and tolerancing per ASME Y14.5M  
BSC: Basic Dimension. Theoretically exact value shown without tolerances.
2. For best soldering results, thermal vias, if used, should be filled or tented to avoid solder loss during reflow process



**Package Outlines and Dimensions**

**48-Lead Ultra Thin Plastic Quad Flat, No Lead Package (PTX) - 6x6 mm Body [UQFN] With Corner Anchors and 4.6x4.6 mm Exposed Pad**

**Note:** For the most current package drawings, please see the Microchip Packaging Specification located at <http://www.microchip.com/packaging>

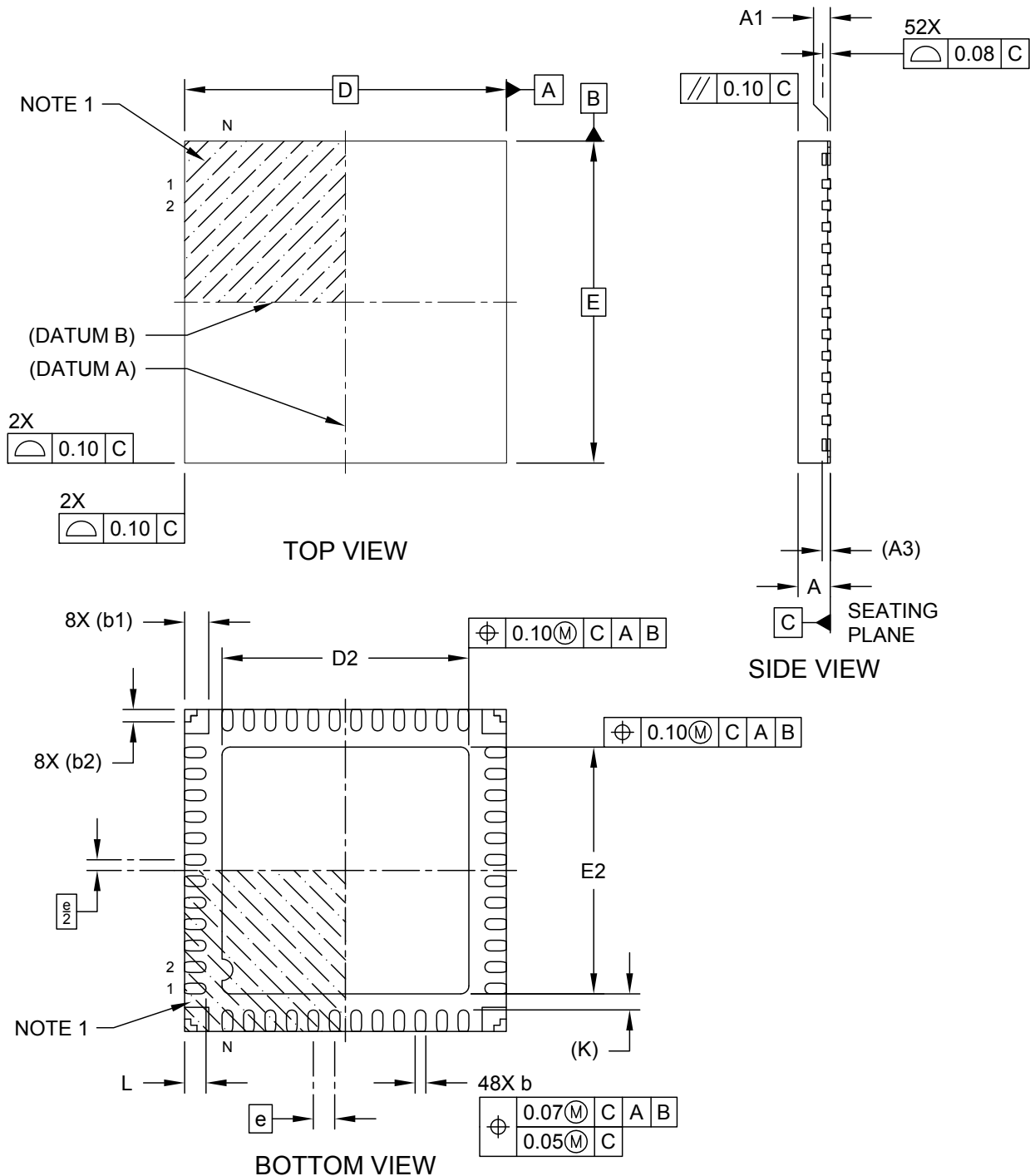

**Package Outlines and Dimensions**

**48-Lead Ultra Thin Plastic Quad Flat, No Lead Package (PTX) - 6x6 mm Body [UQFN]  
With Corner Anchors and 4.6x4.6 mm Exposed Pad**

**Note:** For the most current package drawings, please see the Microchip Packaging Specification located at <http://www.microchip.com/packaging>

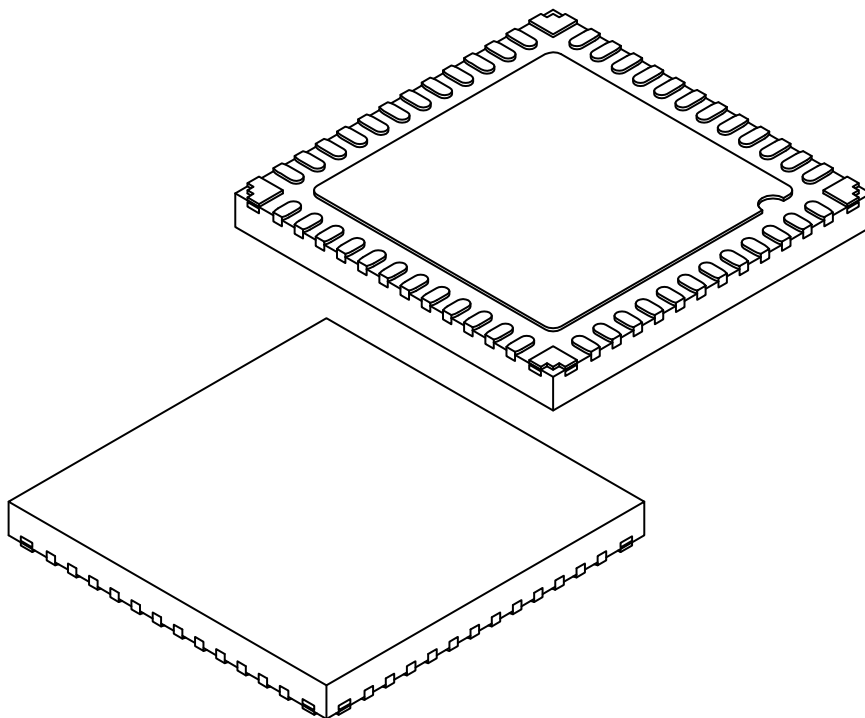

		Units	MILLIMETERS		
Dimension Limits			MIN	NOM	MAX
Number of Terminals	N		48		
Pitch	e		0.40 BSC		
Overall Height	A		0.50	0.55	0.60
Standoff	A1		0.00	0.02	0.05
Terminal Thickness	A3		0.15 REF		
Overall Length	D		6.00 BSC		
Exposed Pad Length	D2		4.50	4.60	4.70
Overall Width	E		6.00 BSC		
Exposed Pad Width	E2		4.50	4.60	4.70
Terminal Width	b		0.15	0.20	0.25
Corner Anchor Pad	b1		0.45 REF		
Corner Anchor Pad, Metal-free Zone	b2		0.23 REF		
Terminal Length	L		0.35	0.40	0.45
Terminal-to-Exposed-Pad	K		0.30 REF		

Notes:

1. Pin 1 visual index feature may vary, but must be located within the hatched area.
2. Package is saw singulated
3. Dimensioning and tolerancing per ASME Y14.5M

BSC: Basic Dimension. Theoretically exact value shown without tolerances.

REF: Reference Dimension, usually without tolerance, for information purposes only.

---



---

## Footprint Outlines and Dimensions

---



---

### 48-Lead Ultra Thin Plastic Quad Flat, No Lead Package (PTX) - 6x6 mm Body [UQFN] With Corner Anchors and 4.6x4.6 mm Exposed Pad

**Note:** For the most current package drawings, please see the Microchip Packaging Specification located at <http://www.microchip.com/packaging>

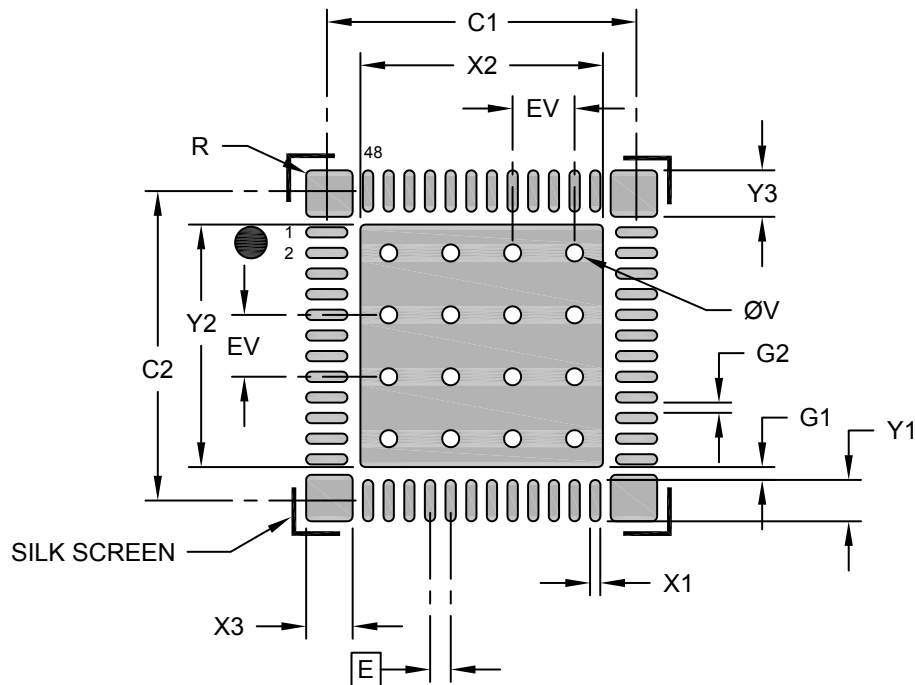

### RECOMMENDED LAND PATTERN

	Units	MILLIMETERS		
		MIN	NOM	MAX
	Dimension Limits			
Contact Pitch	E	0.40 BSC		
Center Pad Width	X2			4.70
Center Pad Length	Y2			4.70
Contact Pad Spacing	C1		6.00	
Contact Pad Spacing	C2		6.00	
Contact Pad Width (X48)	X1			0.20
Contact Pad Length (X48)	Y1			0.80
Corner Anchor Pad Width (X4)	X3			0.90
Corner Anchor Pad Length (X4)	Y3			0.90
Pad Corner Radius (X 20)	R			0.10
Contact Pad to Center Pad (X48)	G1	0.25		
Contact Pad to Contact Pad	G2	0.20		
Thermal Via Diameter	V		0.33	
Thermal Via Pitch	EV		1.20	

**Notes:**

1. Dimensioning and tolerancing per ASME Y14.5M  
BSC: Basic Dimension. Theoretically exact value shown without tolerances.
2. For best soldering results, thermal vias, if used, should be filled or tented to avoid solder loss during reflow process



**MICROCHIP**

---

---

**Package Outlines and Dimensions**

---

---

NOTES:

---

---

**Package Outlines and Dimensions**

---

---

**VQFN**

**Package Outlines and Dimensions**

**10-Lead Very Thin Plastic Quad Flat, No Lead Package (MRA) - 2x2 mm Body [VQFN] With Fused Exposed Pad**

**Note:** For the most current package drawings, please see the Microchip Packaging Specification located at <http://www.microchip.com/packaging>

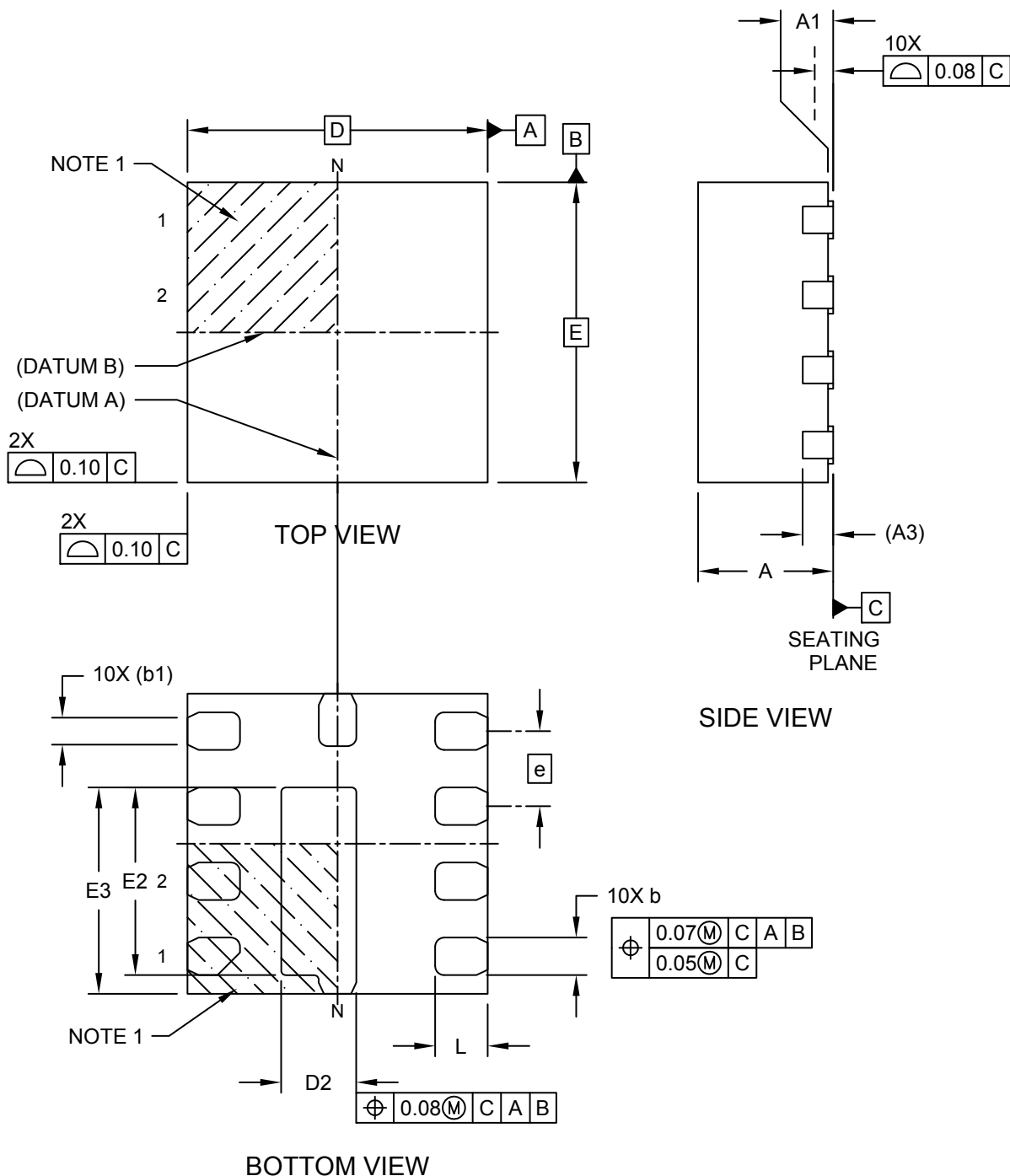

---



---

## Package Outlines and Dimensions

---



---

### 10-Lead Very Thin Plastic Quad Flat, No Lead Package (MRA) - 2x2 mm Body [VQFN] With Fused Exposed Pad

**Note:** For the most current package drawings, please see the Microchip Packaging Specification located at <http://www.microchip.com/packaging>

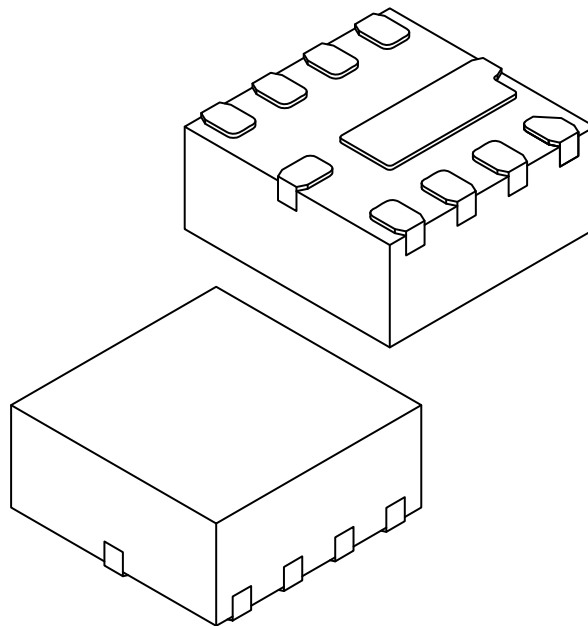

Dimension Limits	Units	MILLIMETERS		
		MIN	NOM	MAX
Number of Terminals	N	10		
Pitch	e	0.50 BSC		
Overall Height	A	0.80	0.85	0.90
Standoff	A1	0.00	0.02	0.05
Terminal Thickness	A3	0.203 REF		
Overall Length	D	2.00 BSC		
Exposed Pad Length	D2	0.45	0.50	0.55
Overall Width	E	2.00 BSC		
Exposed Pad Width	E2	1.20	1.25	1.30
Exposed Pad Width	E3	1.325	1.37	1.425
Terminal Width	b	0.20	0.25	0.30
Terminal Width	b1	0.18 REF		
Terminal Length	L	0.30	0.35	0.40

**Notes:**

1. Pin 1 visual index feature may vary, but must be located within the hatched area.
2. Package is saw singulated
3. Dimensioning and tolerancing per ASME Y14.5M

BSC: Basic Dimension. Theoretically exact value shown without tolerances.

REF: Reference Dimension, usually without tolerance, for information purposes only.

**Footprint Outlines and Dimensions**

**10-Lead Very Thin Plastic Quad Flat, No Lead Package (MRA) - 2x2 mm Body [VQFN] With Fused Exposed Pad**

**Note:** For the most current package drawings, please see the Microchip Packaging Specification located at <http://www.microchip.com/packaging>

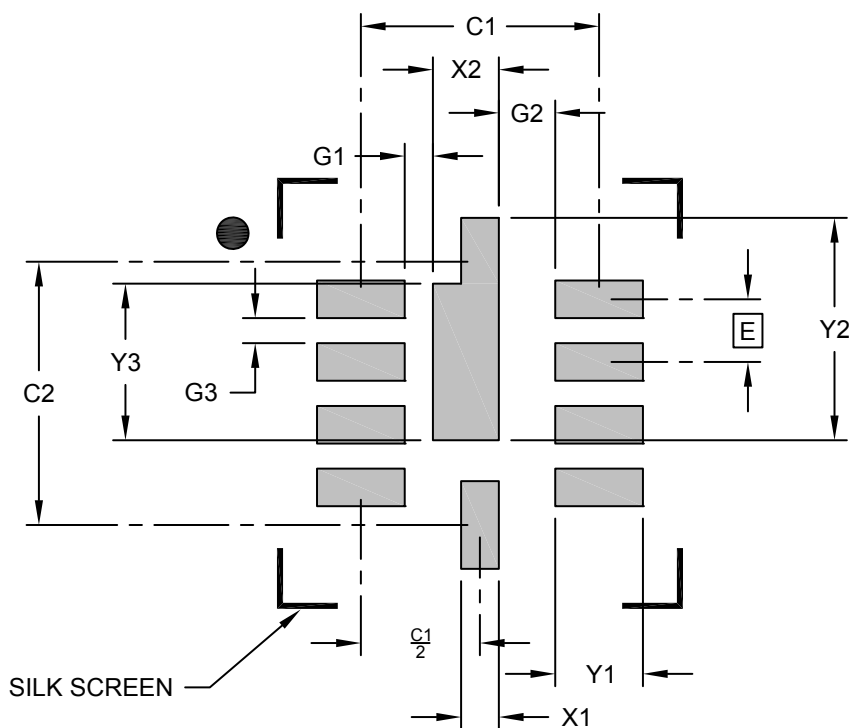

**RECOMMENDED LAND PATTERN**

Dimension Limits	Units	MILLIMETERS		
		MIN	NOM	MAX
Contact Pitch	E	0.50 BSC		
Center Pad Width	X2			0.53
Center Pad Length	Y2			1.77
Center Pad Length	Y3			1.25
Contact Pad Spacing	C1		1.90	
Contact Pad Spacing	C2		2.10	
Contact Pad Width (X10)	X1			0.30
Contact Pad Length (X10)	Y1			0.70
Contact Pad to Center Pad (X3)	G1	0.22		
Contact Pad to Center Pad (X4)	G2	0.45		
Contact Pad to Contact Pad (X6)	G3	0.20		

**Notes:**

1. Dimensioning and tolerancing per ASME Y14.5M  
BSC: Basic Dimension. Theoretically exact value shown without tolerances.
2. For best soldering results, thermal vias, if used, should be filled or tented to avoid solder loss during reflow process





**Package Outlines and Dimensions**

**12-Lead Very Thin Plastic Quad Flat, No Lead Package (UL) - 4x4 mm Body [VQFN]  
SMSC Legacy KP [SQFN]**

**Note:** For the most current package drawings, please see the Microchip Packaging Specification located at <http://www.microchip.com/packaging>

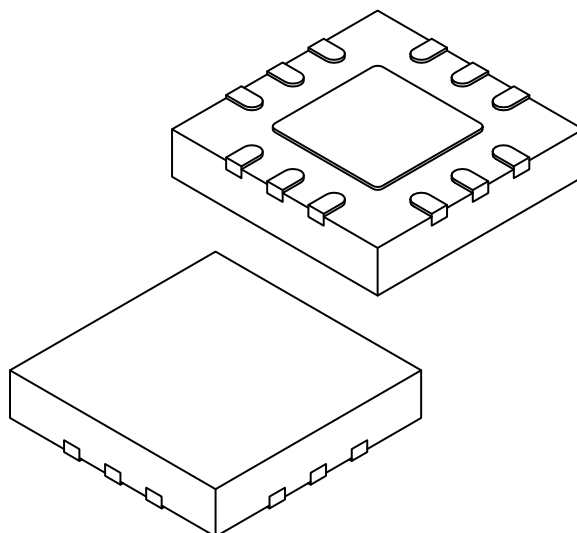

Units		MILLIMETERS		
Dimension Limits		MIN	NOM	MAX
Number of Terminals	N	12		
Pitch	e	0.80 BSC		
Overall Height	A	0.80	0.85	0.90
Standoff	A1	0.00	0.02	0.05
Terminal Thickness	(A3)	0.20 REF		
Overall Width	E	4.00 BSC		
Exposed Pad Width	E2	2.00	2.10	2.20
Overall Length	D	4.00 BSC		
Exposed Pad Length	D2	2.00	2.10	2.20
Terminal Width	b	0.25	0.30	0.35
Terminal Length	L	0.40	0.50	0.60
Terminal-to-Exposed-Pad	K	0.35	-	-

**Notes:**

1. Pin 1 visual index feature may vary, but must be located within the hatched area.
2. Package is saw singulated
3. Dimensioning and tolerancing per ASME Y14.5M

BSC: Basic Dimension. Theoretically exact value shown without tolerances.

REF: Reference Dimension, usually without tolerance, for information purposes only.

---



---

## Footprint Outlines and Dimensions

---



---

### 12-Lead Very Thin Plastic Quad Flat, No Lead Package (UL) - 4x4 mm Body [VQFN] SMSC Legacy KP [SQFN]

**Note:** For the most current package drawings, please see the Microchip Packaging Specification located at <http://www.microchip.com/packaging>

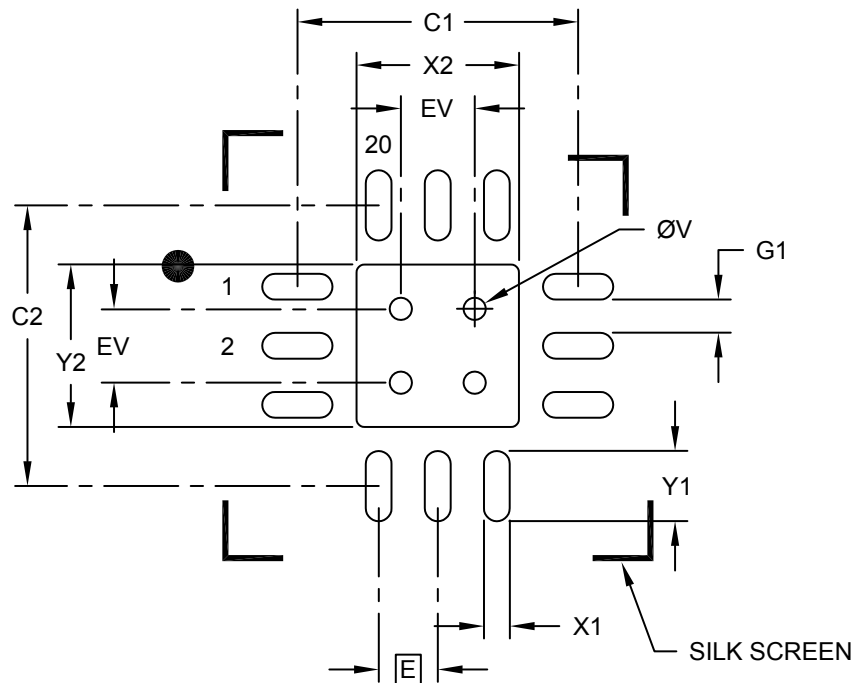

### RECOMMENDED LAND PATTERN

Dimension Limits	Units	MILLIMETERS		
		MIN	NOM	MAX
Contact Pitch	E	0.80 BSC		
Optional Center Pad Width	X2			2.20
Optional Center Pad Length	Y2			2.20
Contact Pad Spacing	C1		4.00	
Contact Pad Spacing	C2		4.00	
Contact Pad Width (X12)	X1			0.37
Contact Pad Length (X12)	Y1			0.95
Contact Pad to Center Pad (X12)	G1	0.45		
Thermal Via Diameter	V		0.30	
Thermal Via Pitch	EV		1.00	

**Notes:**

- Dimensioning and tolerancing per ASME Y14.5M  
BSC: Basic Dimension. Theoretically exact value shown without tolerances.
- For best soldering results, thermal vias, if used, should be filled or tented to avoid solder loss during reflow process

**Package Outlines and Dimensions**

**16-Lead Plastic Quad Flat, No Lead Package (8N) - 3x3x1.0 mm Body [VQFN]  
Wettable Flanks (Stepped), 0.35 mm Terminal Length**

**Note:** For the most current package drawings, please see the Microchip Packaging Specification located at <http://www.microchip.com/packaging>

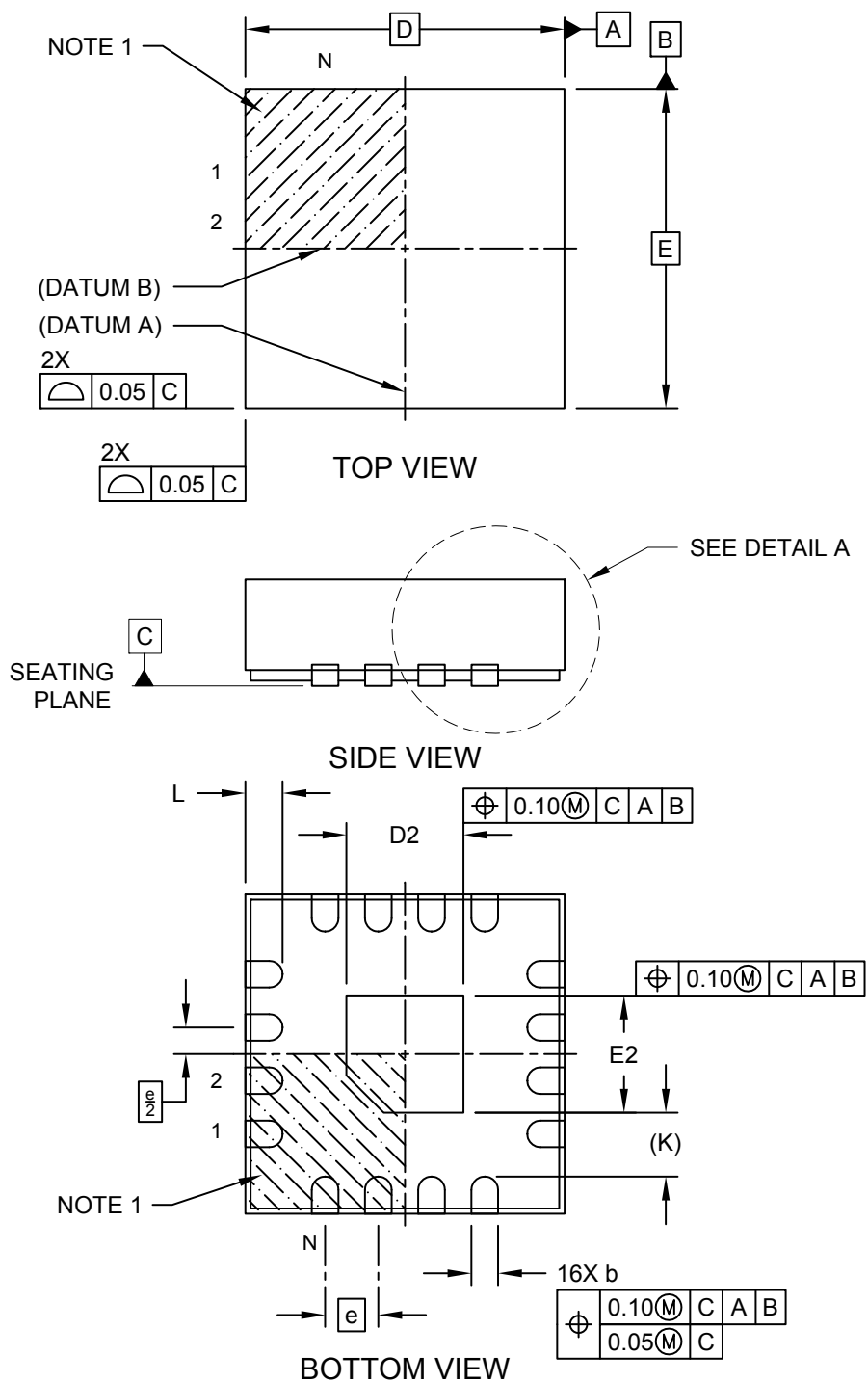

---



---

## Package Outlines and Dimensions

---



---

### 16-Lead Plastic Quad Flat, No Lead Package (8N) - 3x3x1.0 mm Body [VQFN] Wettable Flanks (Stepped), 0.35 mm Terminal Length

**Note:** For the most current package drawings, please see the Microchip Packaging Specification located at <http://www.microchip.com/packaging>

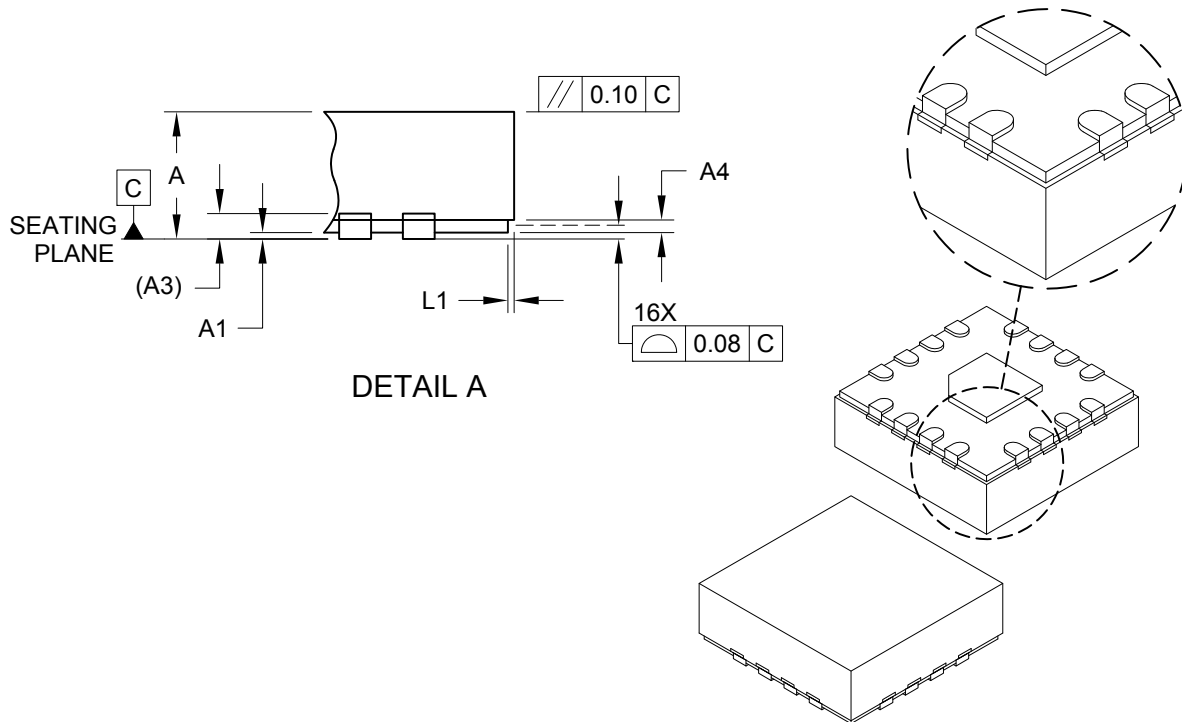

Dimension Limits	Units	MILLIMETERS		
		MIN	NOM	MAX
Number of Terminals	N	16		
Pitch	e	0.50 BSC		
Overall Height	A	0.80	0.90	1.00
Standoff	A1	0.00	0.02	0.05
Terminal Thickness	A3	0.20 REF		
Step Height	A4	0.05	0.12	0.19
Overall Width	E	3.00 BSC		
Exposed Pad Width	E2	1.00	1.10	1.20
Overall Length	D	3.00 BSC		
Exposed Pad Length	D2	1.00	1.10	1.20
Terminal Width	b	0.20	0.25	0.30
Terminal Length	L	0.25	0.35	0.45
Step Length	L1	0.035	0.060	0.085
Terminal-to-Exposed Pad	K	0.60 REF		

**Notes:**

1. Pin 1 visual index feature may vary, but must be located within the hatched area.
2. Package is saw singulated
3. Dimensioning and tolerancing per ASME Y14.5M
  - BSC: Basic Dimension. Theoretically exact value shown without tolerances.
  - REF: Reference Dimension, usually without tolerance, for information purposes only.

**Footprint Outlines and Dimensions**

**16-Lead Plastic Quad Flat, No Lead Package (8N) - 3x3x1.0 mm Body [VQFN]  
Wettable Flanks (Stepped), 0.35 mm Terminal Length**

**Note:** For the most current package drawings, please see the Microchip Packaging Specification located at <http://www.microchip.com/packaging>

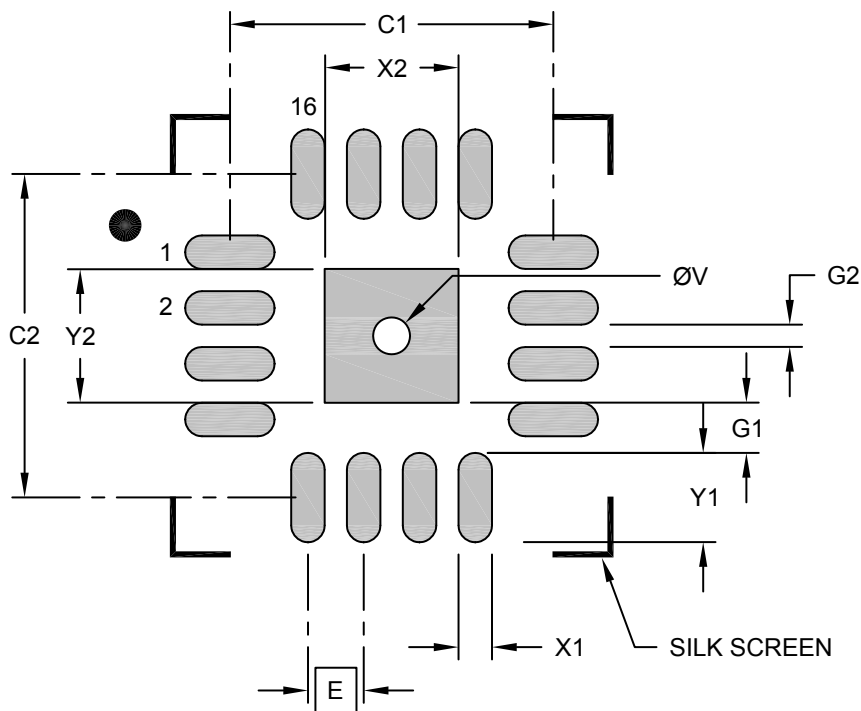

**RECOMMENDED LAND PATTERN**

Dimension Limits	Units	MILLIMETERS		
		MIN	NOM	MAX
Contact Pitch	E	0.50 BSC		
Optional Center Pad Width	X2			1.20
Optional Center Pad Length	Y2			1.20
Contact Pad Spacing	C1		2.90	
Contact Pad Spacing	C2		2.90	
Contact Pad Width (X16)	X1			0.30
Contact Pad Length (X16)	Y1			0.80
Contact Pad to Center Pad (X16)	G1	0.30		
Contact Pad to Contact Pad (X12)	G2	0.20		
Thermal Via Diameter	V		0.33	

**Notes:**

1. Dimensioning and tolerancing per ASME Y14.5M  
BSC: Basic Dimension. Theoretically exact value shown without tolerances.
2. For best soldering results, thermal vias, if used, should be filled or tented to avoid solder loss during reflow process

**Package Outlines and Dimensions**

**16-Lead Very Thin Plastic Quad Flat, No Lead Package (MG) - 3x3 mm Body [VQFN]  
With 1.1x1.1 mm Exposed Pad**

**Note:** For the most current package drawings, please see the Microchip Packaging Specification located at <http://www.microchip.com/packaging>

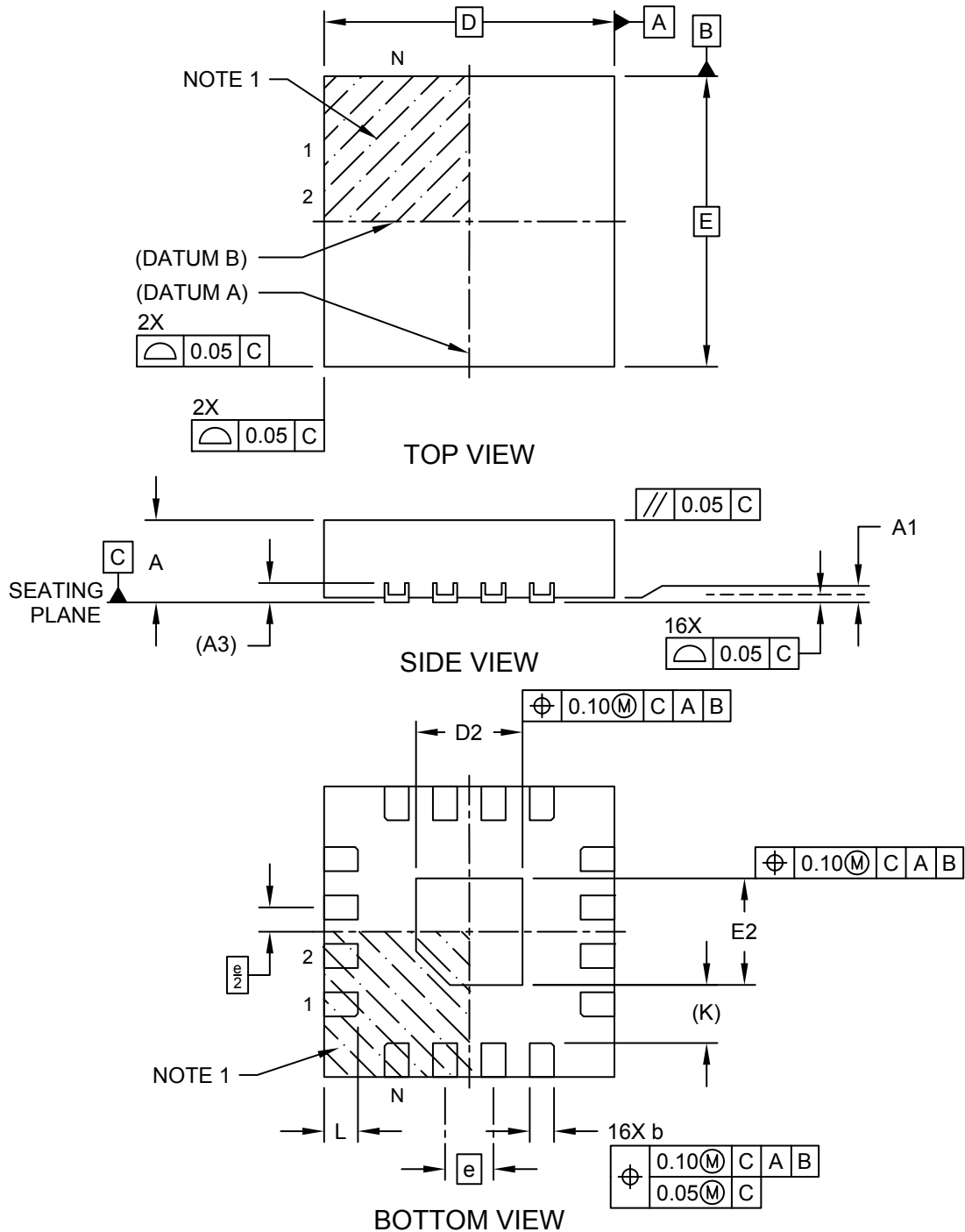

**Package Outlines and Dimensions**

**16-Lead Very Thin Plastic Quad Flat, No Lead Package (MG) - 3x3 mm Body [VQFN]  
With 1.1x1.1 mm Exposed Pad**

**Note:** For the most current package drawings, please see the Microchip Packaging Specification located at <http://www.microchip.com/packaging>

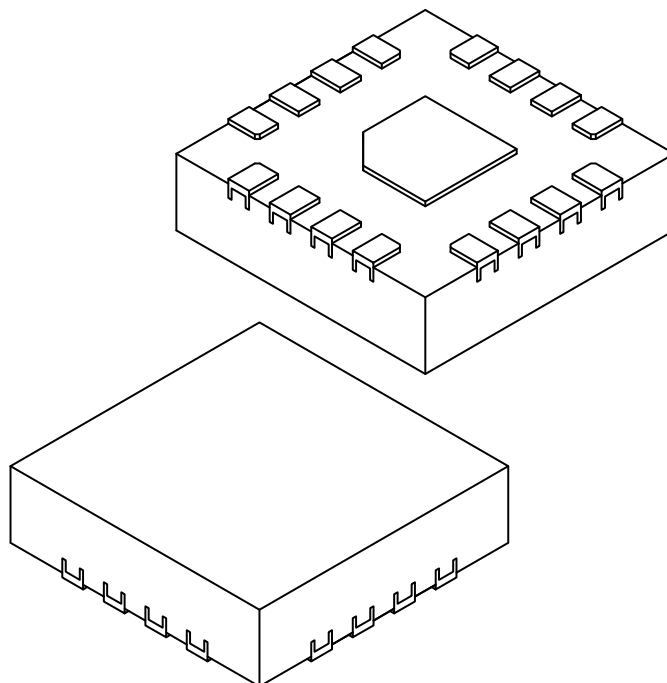

		Units	MILLIMETERS		
Dimension Limits			MIN	NOM	MAX
Number of Terminals	N		16		
Pitch	e		0.50 BSC		
Overall Height	A	0.80	0.85	0.90	
Standoff	A1	0.00	0.02	0.05	
Terminal Thickness	A3	0.20 REF			
Overall Length	D	3.00 BSC			
Exposed Pad Length	D2	1.00	1.10	1.20	
Overall Width	E	3.00 BSC			
Exposed Pad Width	E2	1.00	1.10	1.20	
Terminal Width	b	0.20	0.25	0.30	
Terminal Length	L	0.25	0.35	0.45	
Terminal-to-Exposed-Pad	K	0.60 (REF)			

**Notes:**

1. Pin 1 visual index feature may vary, but must be located within the hatched area.
2. Package is saw singulated
3. Dimensioning and tolerancing per ASME Y14.5M

BSC: Basic Dimension. Theoretically exact value shown without tolerances.

REF: Reference Dimension, usually without tolerance, for information purposes only.



**Package Outlines and Dimensions**

**16-Lead Very Thin Plastic Quad Flat, No Lead Package (MG) - 3x3 mm Body [VQFN]  
With 1.65x1.65 mm Exposed Pad (Supertex Legacy)**

**Note:** For the most current package drawings, please see the Microchip Packaging Specification located at <http://www.microchip.com/packaging>

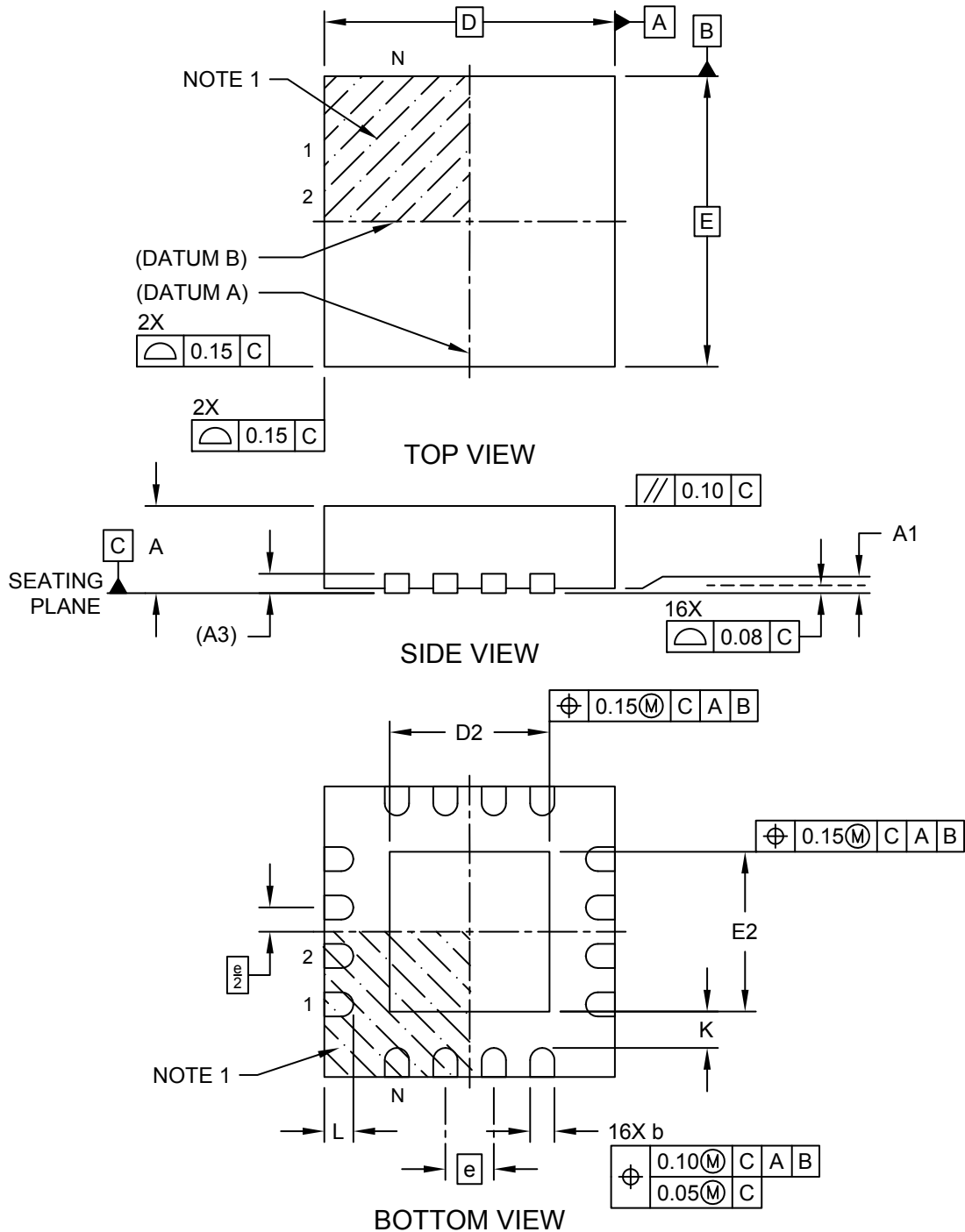

**Package Outlines and Dimensions**

**16-Lead Very Thin Plastic Quad Flat, No Lead Package (MG) - 3x3 mm Body [VQFN]  
With 1.65x1.65 mm Exposed Pad (Supertex Legacy)**

**Note:** For the most current package drawings, please see the Microchip Packaging Specification located at <http://www.microchip.com/packaging>

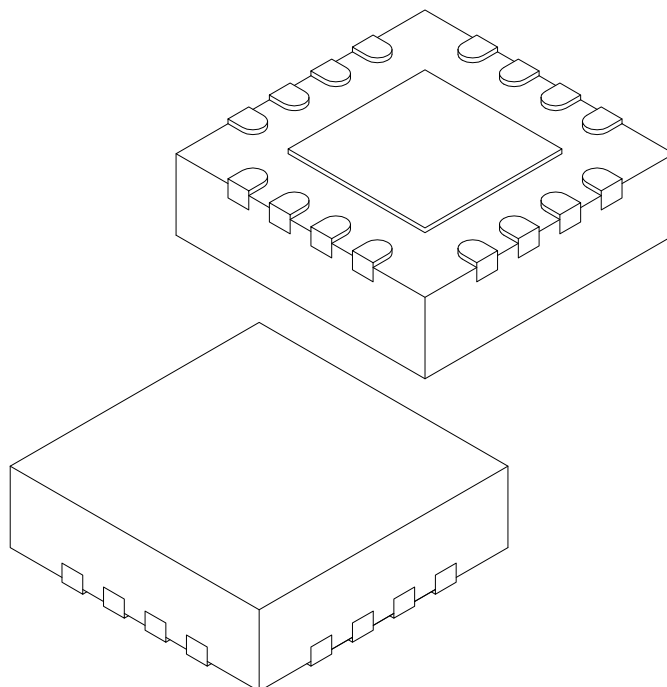

Dimension Limits	Units	MILLIMETERS		
		MIN	NOM	MAX
Number of Terminals	N	16		
Pitch	e	0.50 BSC		
Overall Height	A	0.80	0.90	1.00
Standoff	A1	0.00	0.02	0.05
Terminal Thickness	A3	0.20 REF		
Overall Length	D	3.00 BSC		
Exposed Pad Length	D2	1.50	1.65	1.80
Overall Width	E	3.00 BSC		
Exposed Pad Width	E2	1.50	1.65	1.80
Terminal Width	b	0.18	0.25	0.30
Terminal Length	L	0.20	0.30	0.45
Terminal-to-Exposed-Pad	K	0.20	-	-

**Notes:**

1. Pin 1 visual index feature may vary, but must be located within the hatched area.
2. Package is saw singulated
3. Dimensioning and tolerancing per ASME Y14.5M
  - BSC: Basic Dimension. Theoretically exact value shown without tolerances.
  - REF: Reference Dimension, usually without tolerance, for information purposes only.

---



---

## Footprint Outlines and Dimensions

---



---

### 16-Lead Very Thin Plastic Quad Flat, No Lead Package (MG) - 3x3 mm Body [VQFN] With 1.65x1.65 mm Exposed Pad (Supertex Legacy)

**Note:** For the most current package drawings, please see the Microchip Packaging Specification located at <http://www.microchip.com/packaging>

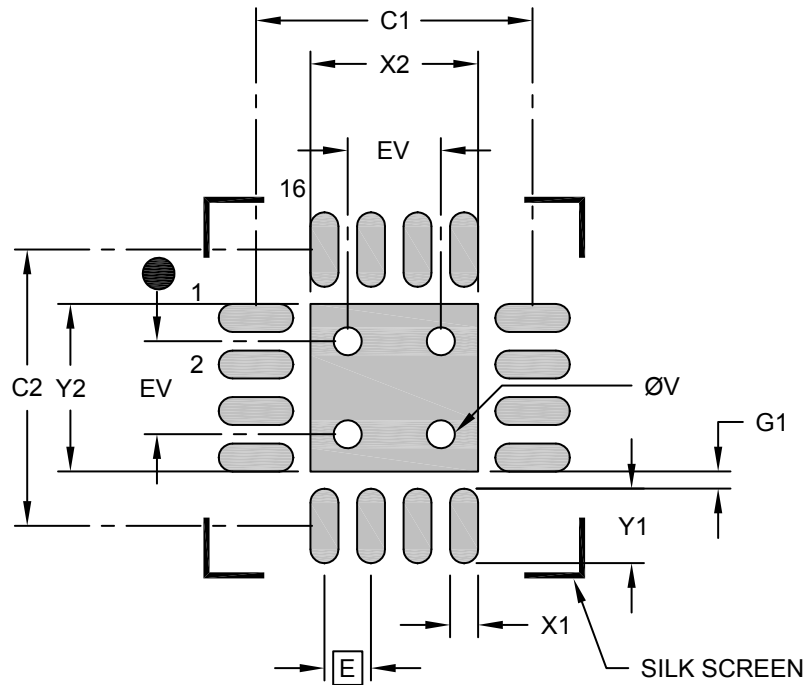

### RECOMMENDED LAND PATTERN

Dimension Limits	Units	MILLIMETERS		
		MIN	NOM	MAX
Contact Pitch	E	0.50 BSC		
Optional Center Pad Width	X2			1.80
Optional Center Pad Length	Y2			1.80
Contact Pad Spacing	C1		3.00	
Contact Pad Spacing	C2		3.00	
Contact Pad Width (X16)	X1			0.30
Contact Pad Length (X16)	Y1			0.80
Contact Pad to Center Pad (X16)	G1	0.20		
Thermal Via Diameter	V		0.30	
Thermal Via Pitch	EV		1.00	

**Notes:**

1. Dimensioning and tolerancing per ASME Y14.5M  
BSC: Basic Dimension. Theoretically exact value shown without tolerances.
2. For best soldering results, thermal vias, if used, should be filled or tented to avoid solder loss during reflow process

**Package Outlines and Dimensions**

**16-Lead Very Thin Plastic Quad Flat, No Lead Package (AP) - 4x4 mm Body [VQFN]  
SMSC Legacy AP [SQFN]**

**Note:** For the most current package drawings, please see the Microchip Packaging Specification located at <http://www.microchip.com/packaging>

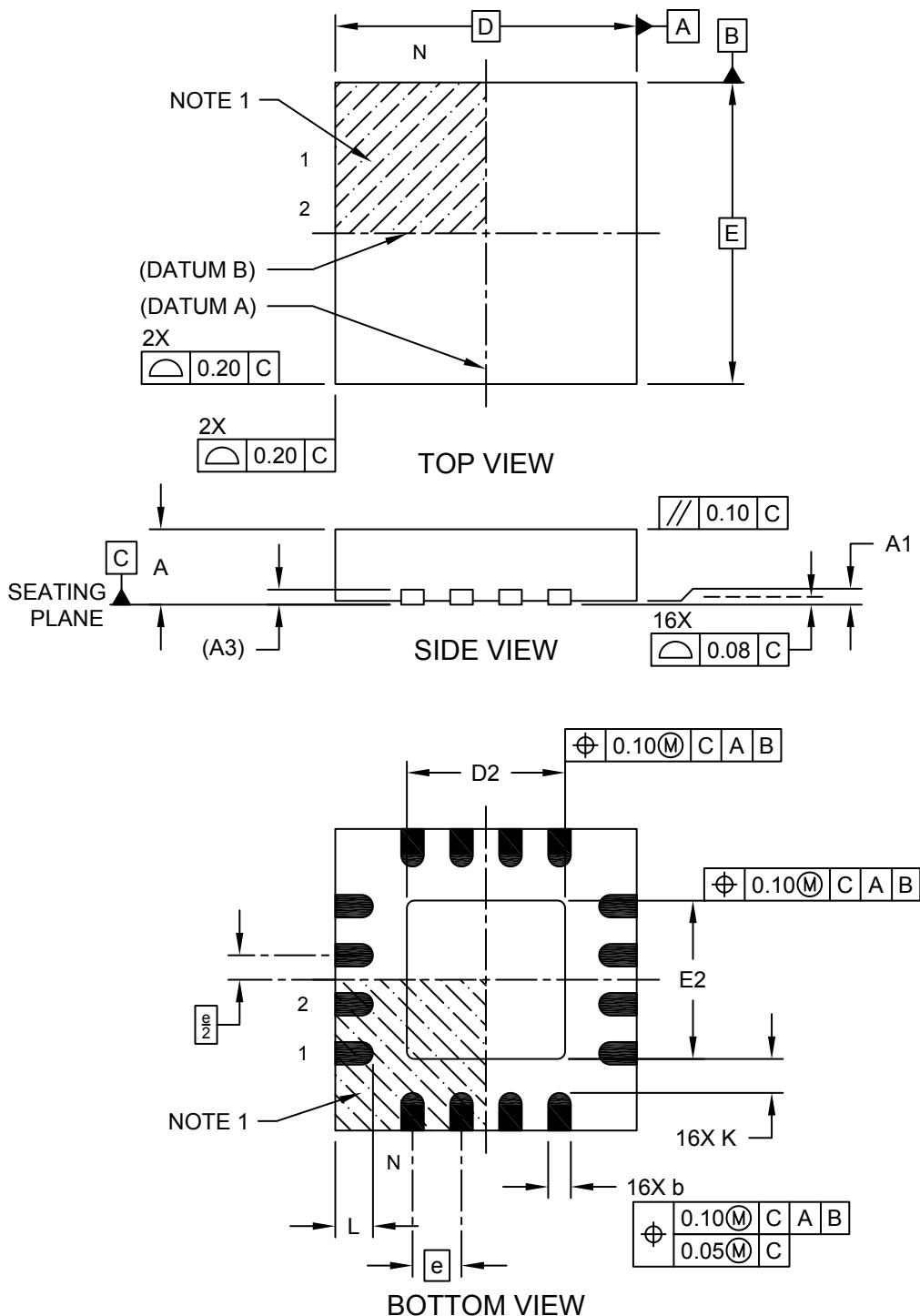

---



---

## Package Outlines and Dimensions

---



---

### 16-Lead Very Thin Plastic Quad Flat, No Lead Package (AP) - 4x4 mm Body [VQFN] SMSC Legacy AP [SQFN]

**Note:** For the most current package drawings, please see the Microchip Packaging Specification located at <http://www.microchip.com/packaging>

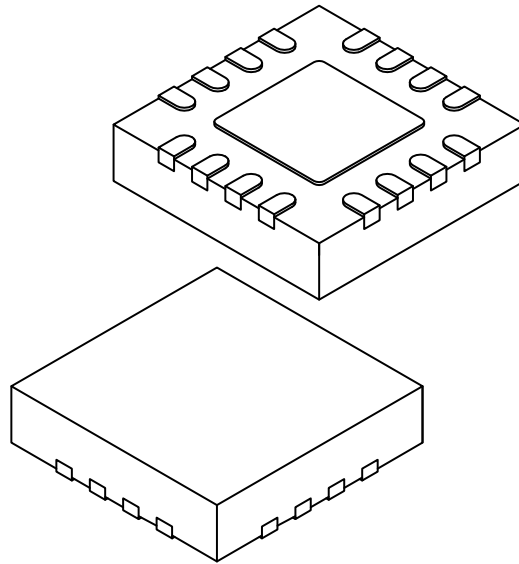

Dimension Limits		MILLIMETERS		
		MIN	NOM	MAX
Number of Terminals	N	16		
Pitch	e	0.65 BSC		
Overall Height	A	0.80	0.90	1.00
Standoff	A1	0.00	0.02	0.05
Terminal Thickness	A3	0.20 REF		
Overall Width	E	4.00 BSC		
Exposed Pad Width	E2	2.00	2.10	2.20
Overall Length	D	4.00 BSC		
Exposed Pad Length	D2	2.00	2.10	2.20
Terminal Width	b	0.25	0.30	0.35
Terminal Length	L	0.40	0.50	0.60
Terminal-to-Exposed-Pad	K	0.35	-	-

**Notes:**

1. Pin 1 visual index feature may vary, but must be located within the hatched area.
2. Package is saw singulated
3. Dimensioning and tolerancing per ASME Y14.5M
  - BSC: Basic Dimension. Theoretically exact value shown without tolerances.
  - REF: Reference Dimension, usually without tolerance, for information purposes only.

**Footprint Outlines and Dimensions**

**16-Lead Very Thin Plastic Quad Flat, No Lead Package (AP) - 4x4 mm Body [VQFN]  
SMSC Legacy AP [SQFN]**

**Note:** For the most current package drawings, please see the Microchip Packaging Specification located at <http://www.microchip.com/packaging>

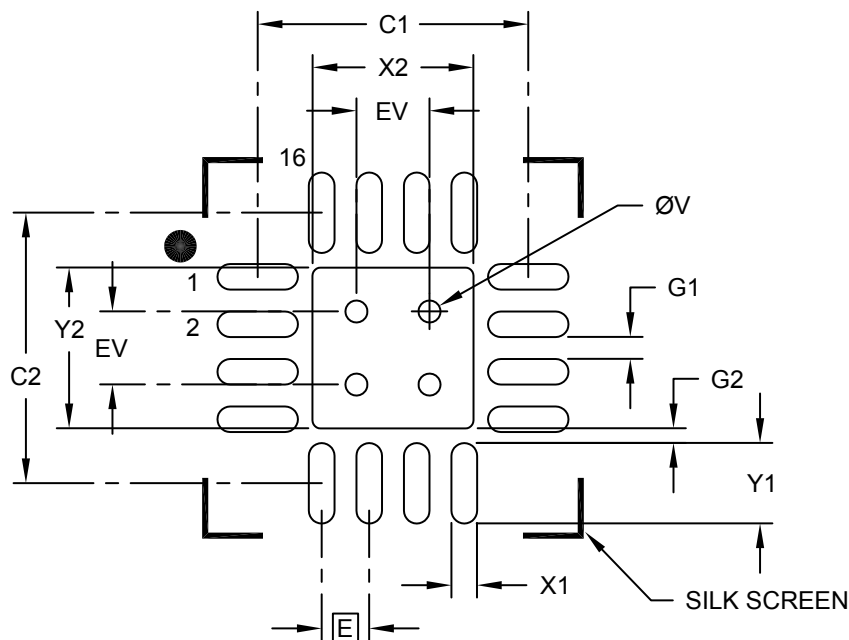

**RECOMMENDED LAND PATTERN**

Dimension Limits	Units	MILLIMETERS		
		MIN	NOM	MAX
Contact Pitch	E	0.65 BSC		
Optional Center Pad Width	X2			2.20
Optional Center Pad Length	Y2			2.20
Contact Pad Spacing	C1		3.70	
Contact Pad Spacing	C2		3.70	
Contact Pad Width (X16)	X1			0.37
Contact Pad Length (X16)	Y1		0.79	1.10
Space Between Pads	G1	0.30		
Contact Pad to Center Pad (X16)	G2	0.20		
Thermal Via Diameter	V		0.30	
Thermal Via Pitch	EV		1.00	

**Notes:**

1. Dimensioning and tolerancing per ASME Y14.5M  
BSC: Basic Dimension. Theoretically exact value shown without tolerances.
2. For best soldering results, thermal vias, if used, should be filled or tented to avoid solder loss during reflow process

**Package Outlines and Dimensions**

**16-Lead Plastic Quad Flat, No Lead Package (7N) - 4x4x1.0 mm Body [VQFN]  
Wettable Flanks (Stepped), 0.40 mm Terminal Length**

**Note:** For the most current package drawings, please see the Microchip Packaging Specification located at <http://www.microchip.com/packaging>

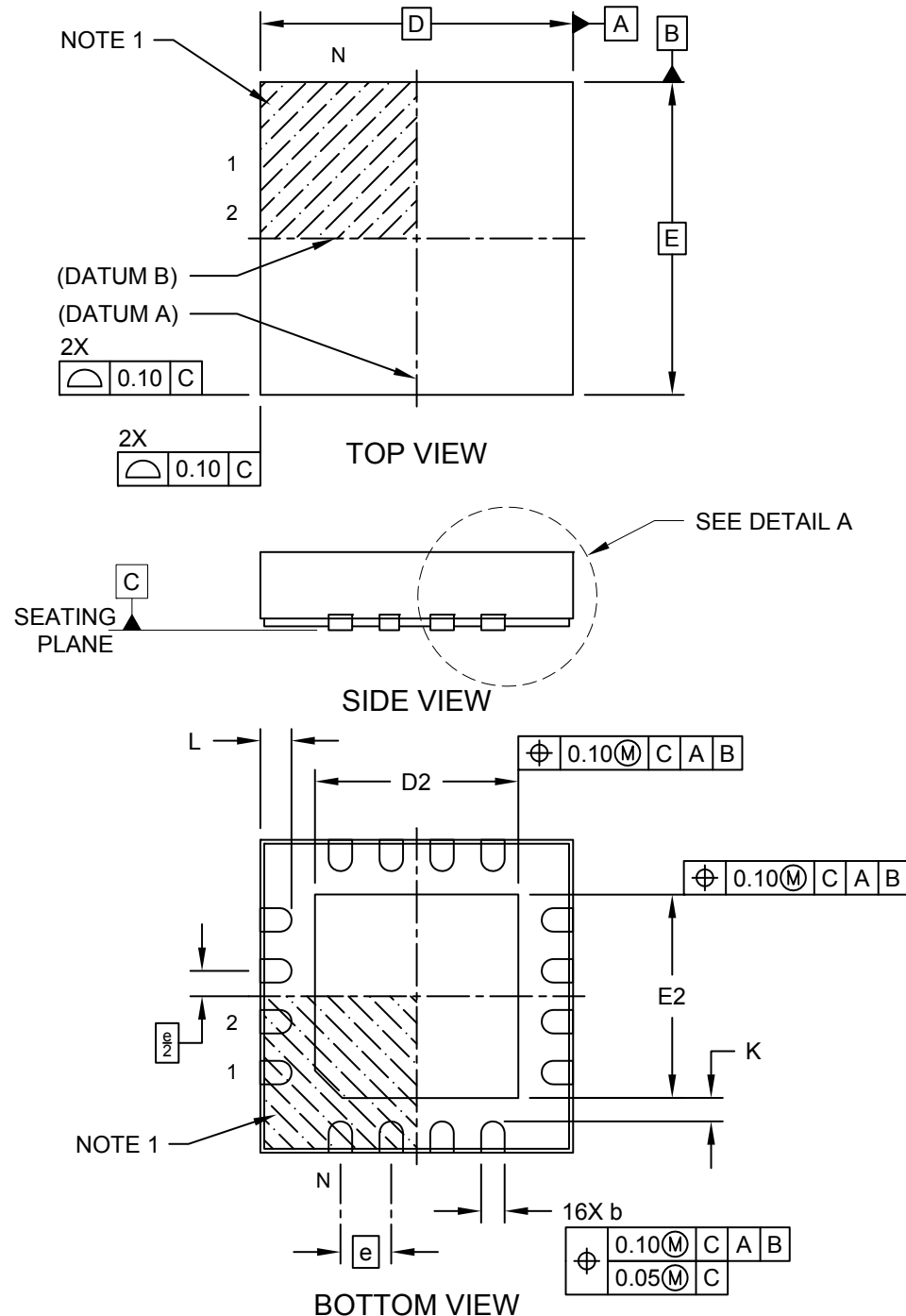

**Package Outlines and Dimensions**

**16-Lead Plastic Quad Flat, No Lead Package (7N) - 4x4x1.0 mm Body [VQFN]  
Wettable Flanks (Stepped), 0.40 mm Terminal Length**

**Note:** For the most current package drawings, please see the Microchip Packaging Specification located at <http://www.microchip.com/packaging>

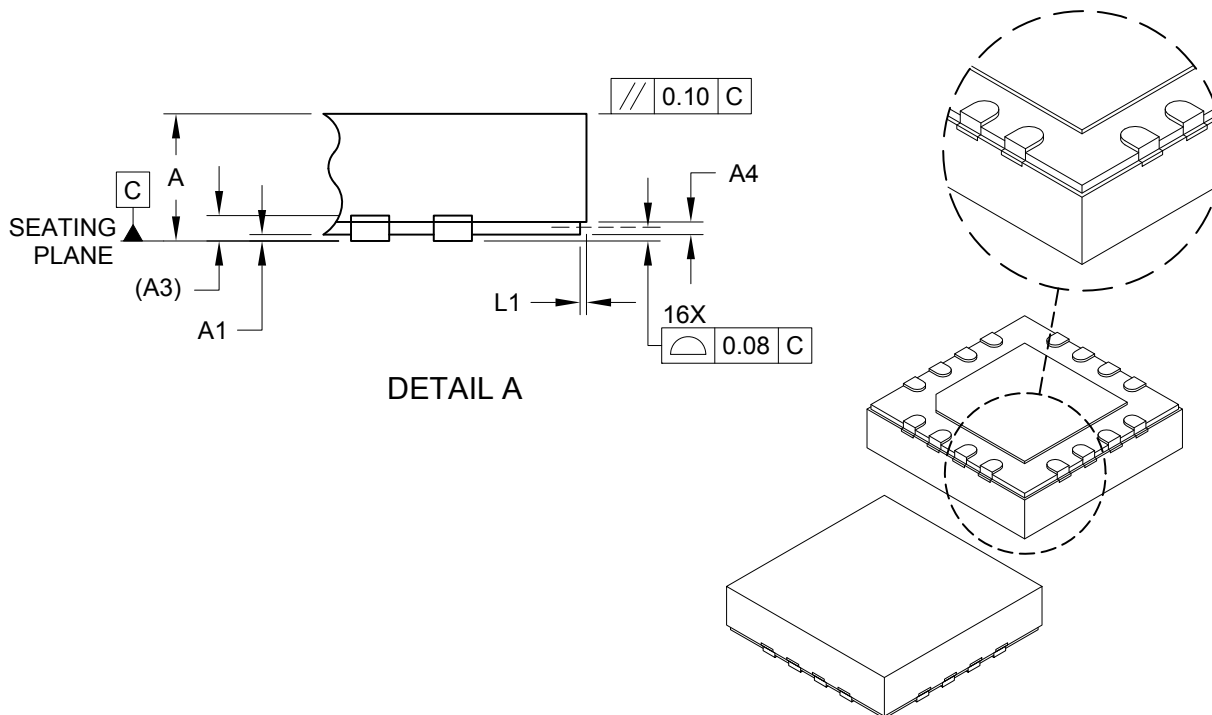

Dimension Limits	Units	MILLIMETERS		
		MIN	NOM	MAX
Number of Terminals	N	16		
Pitch	e	0.65 BSC		
Overall Height	A	0.80	0.90	1.00
Standoff	A1	0.00	0.02	0.05
Terminal Thickness	A3	0.20 REF		
Step Height	A4	0.05	0.12	0.19
Overall Width	E	4.00 BSC		
Exposed Pad Width	E2	2.50	2.60	2.70
Overall Length	D	4.00 BSC		
Exposed Pad Length	D2	2.50	2.60	2.70
Terminal Width	b	0.25	0.30	0.35
Terminal Length	L	0.30	0.40	0.50
Step Length	L1	0.035	0.060	0.085
Terminal-to-Exposed Pad	K	0.30	-	-

**Notes:**

- Pin 1 visual index feature may vary, but must be located within the hatched area.
- Package is saw singulated
- Dimensioning and tolerancing per ASME Y14.5M
  - BSC: Basic Dimension. Theoretically exact value shown without tolerances.
  - REF: Reference Dimension, usually without tolerance, for information purposes only.



---



---

## Footprint Outlines and Dimensions

---



---

### 16-Lead Plastic Quad Flat, No Lead Package (7N) - 4x4x1.0 mm Body [VQFN] Wettable Flanks (Stepped), 0.40 mm Terminal Length

**Note:** For the most current package drawings, please see the Microchip Packaging Specification located at <http://www.microchip.com/packaging>

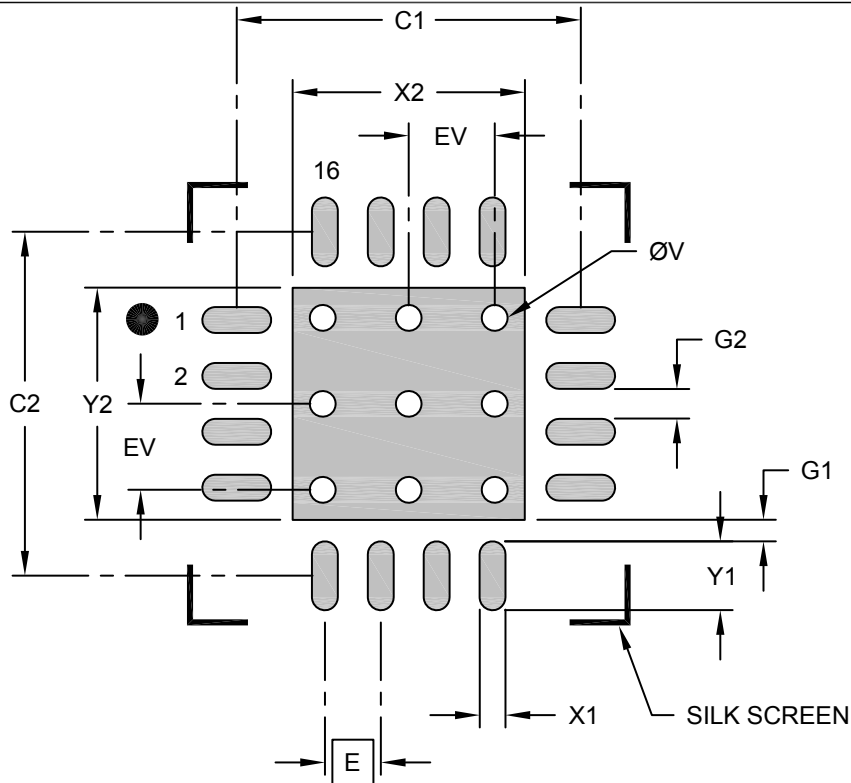

**RECOMMENDED LAND PATTERN**

Dimension Limits	Units	MILLIMETERS		
		MIN	NOM	MAX
Contact Pitch	E	0.65 BSC		
Optional Center Pad Width	X2			2.70
Optional Center Pad Length	Y2			2.70
Contact Pad Spacing	C1		4.00	
Contact Pad Spacing	C2		4.00	
Contact Pad Width (X16)	X1			0.30
Contact Pad Length (X16)	Y1			0.80
Contact Pad to Center Pad (X16)	G1	0.20		
Contact Pad to Contact Pad (X12)	G2	0.35		
Thermal Via Diameter	V		0.30	
Thermal Via Pitch	EV		1.00	

**Notes:**

1. Dimensioning and tolerancing per ASME Y14.5M  
BSC: Basic Dimension. Theoretically exact value shown without tolerances.
2. For best soldering results, thermal vias, if used, should be filled or tented to avoid solder loss during reflow process

**Package Outlines and Dimensions**

**16-Lead Very Thin Quad Flat, No Lead Package (7E) - 4x4 mm Body [VQFN]  
With 2.1x2.1 mm Exposed Pad; Punch Singulated; Dimpled Terminals**

**Note:** For the most current package drawings, please see the Microchip Packaging Specification located at <http://www.microchip.com/packaging>

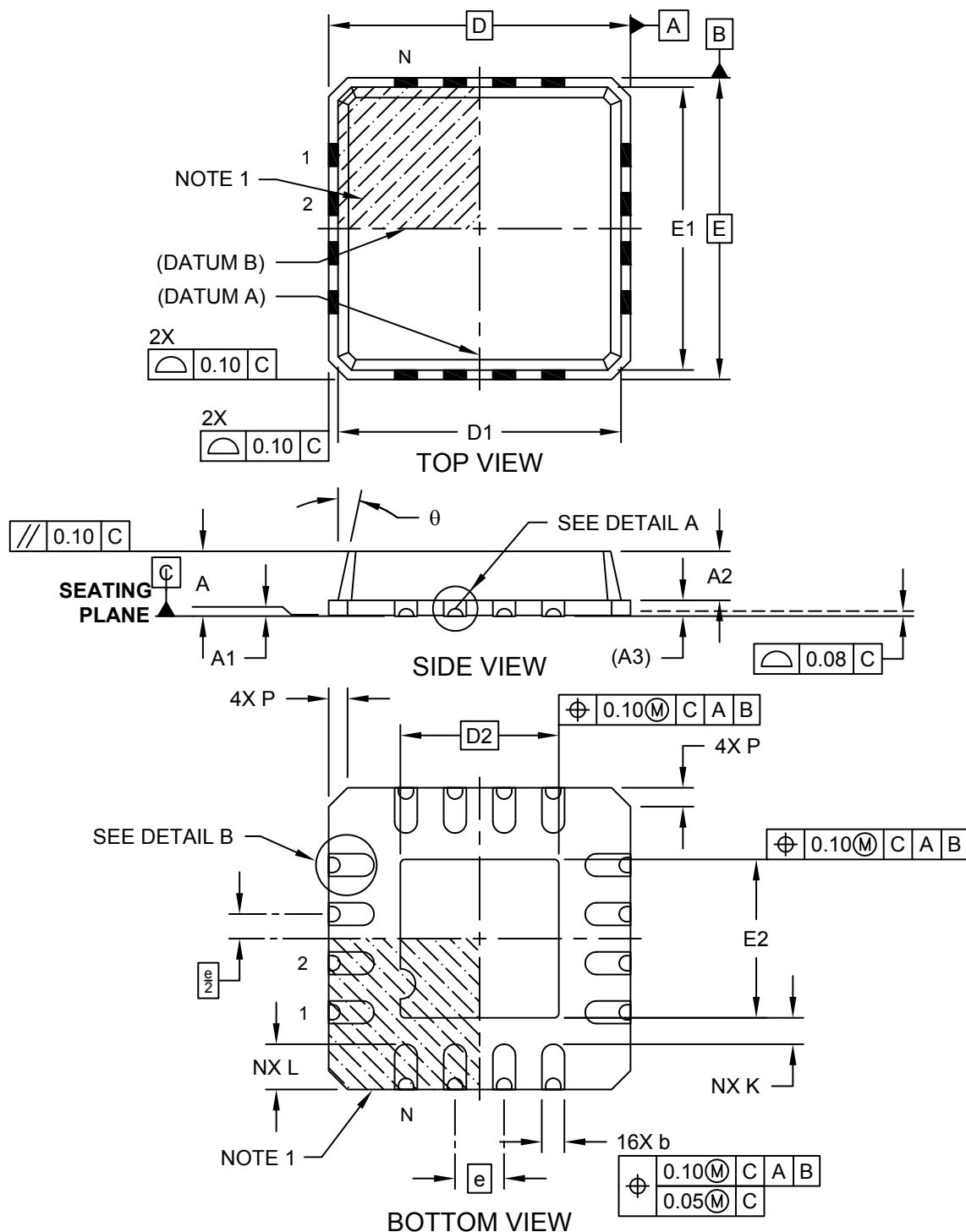

Microchip Technology Drawing C04-362B Sheet 1 of 2

---



---

## Package Outlines and Dimensions

---



---

### 16-Lead Very Thin Quad Flat, No Lead Package (7E) - 4x4 mm Body [VQFN] With 2.1x2.1 mm Exposed Pad; Punch Singulated; Dimpled Terminals

**Note:** For the most current package drawings, please see the Microchip Packaging Specification located at <http://www.microchip.com/packaging>

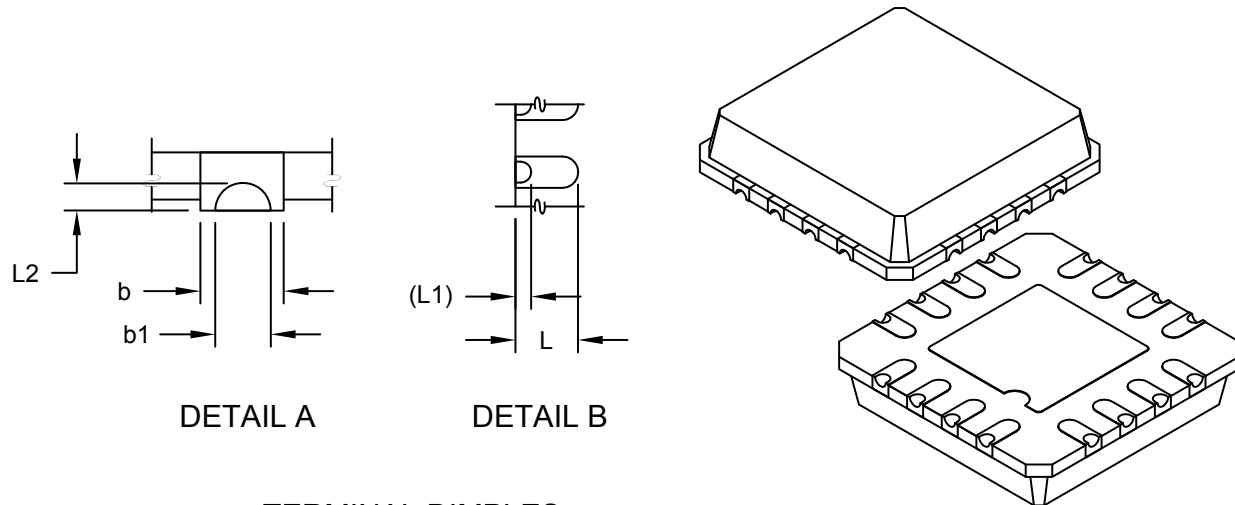

#### TERMINAL DIMPLES

	Units	MILLIMETERS		
		MIN	NOM	MAX
Number of Pins	N	16		
Pitch	e	0.65 BSC		
Overall Height	A	0.80	0.85	0.90
Standoff	A1	0.00	0.01	0.05
Mold Cap Height	A2	0.60	0.65	0.70
Terminal Thickness	(A3)	0.20 REF		
Overall Width	E	4.00 BSC		
Molded Top Width	E1	3.75 BSC		
Exposed Pad Width	E2	2.00	2.10	2.20
Overall Length	D	4.00 BSC		
Molded Top Length	D1	3.75 BSC		
Exposed Pad Length	D2	2.00	2.10	2.20
Corner Chamfer	P	-	-	0.60
Terminal Width	b	0.25	0.30	0.35
Terminal Dimple Width	b1	0.15	0.20	0.25
Terminal Length	L	0.50	0.60	0.75
Terminal Dimple Length	L1	0.15 REF		
Terminal Dimple Depth	L2	0.05	0.10	0.15
Terminal-to-Exposed-Pad	K	0.20	-	-
Mold Draft Angle	$\theta$	0°	-	12°

**Notes:**

1. Pin 1 visual index feature may vary, but must be located within the hatched area.
2. Package is punch singulated
3. Dimensioning and tolerancing per ASME Y14.5M

BSC: Basic Dimension. Theoretically exact value shown without tolerances.

REF: Reference Dimension, usually without tolerance, for information purposes only.

**Footprint Outlines and Dimensions**

**16-Lead Very Thin Quad Flat, No Lead Package (7E) - 4x4 mm Body [VQFN]  
With 2.1x2.1 mm Exposed Pad; Punch Singulated; Dimpled Terminals**

**Note:** For the most current package drawings, please see the Microchip Packaging Specification located at <http://www.microchip.com/packaging>

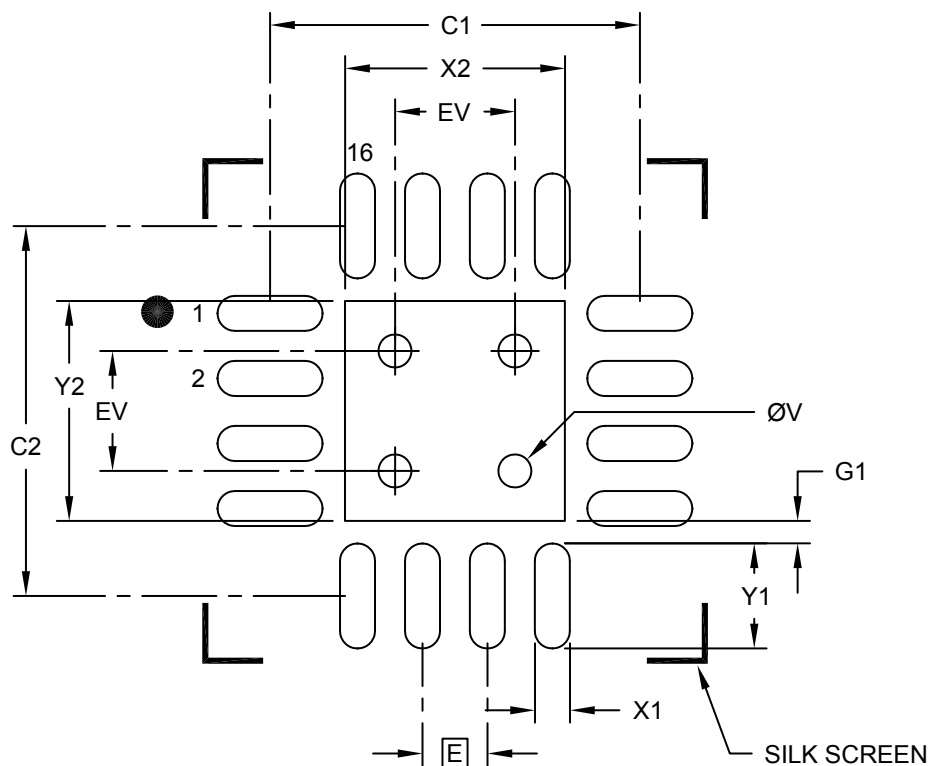

**RECOMMENDED LAND PATTERN**

Dimension Limits	Units	MILLIMETERS		
		MIN	NOM	MAX
Contact Pitch	E	0.65 BSC		
Optional Center Pad Width	X2			2.20
Optional Center Pad Length	Y2			2.20
Contact Pad Spacing	C1		3.70	
Contact Pad Spacing	C2		3.70	
Contact Pad Width (X16)	X1			0.35
Contact Pad Length (X16)	Y1			1.05
Contact Pad to Center Pad (X16)	G1	0.20		
Thermal Via Diameter	V		0.33	
Thermal Via Pitch	EV		1.20	

**Notes:**

- Dimensioning and tolerancing per ASME Y14.5M  
BSC: Basic Dimension. Theoretically exact value shown without tolerances.
- For best soldering results, thermal vias, if used, should be filled or tented to avoid solder loss during reflow process

Microchip Technology Drawing C04-2362A

**Package Outlines and Dimensions**

**16-Lead Plastic Quad Flat, No Lead Package (8N) - 3x3x1.0 mm Body [VQFN]  
Wettable Flanks (Stepped), 0.35 mm Terminal Length**

**Note:** For the most current package drawings, please see the Microchip Packaging Specification located at <http://www.microchip.com/packaging>

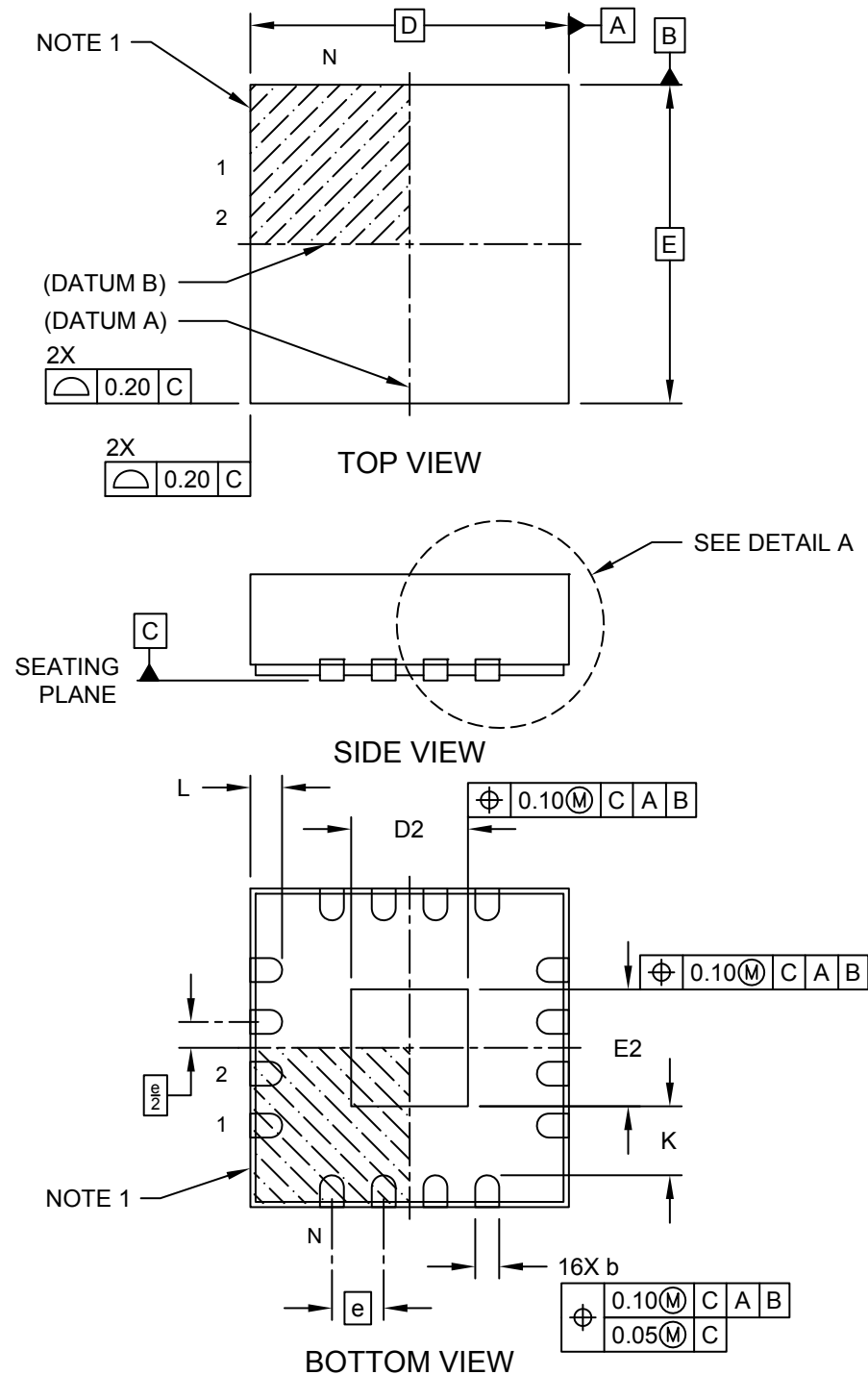

Microchip Technology Drawing C04-404B Sheet 1 of 2

**Package Outlines and Dimensions**

**16-Lead Plastic Quad Flat, No Lead Package (8N) - 3x3x1.0 mm Body [VQFN]  
Wettable Flanks (Stepped), 0.35 mm Terminal Length**

**Note:** For the most current package drawings, please see the Microchip Packaging Specification located at <http://www.microchip.com/packaging>

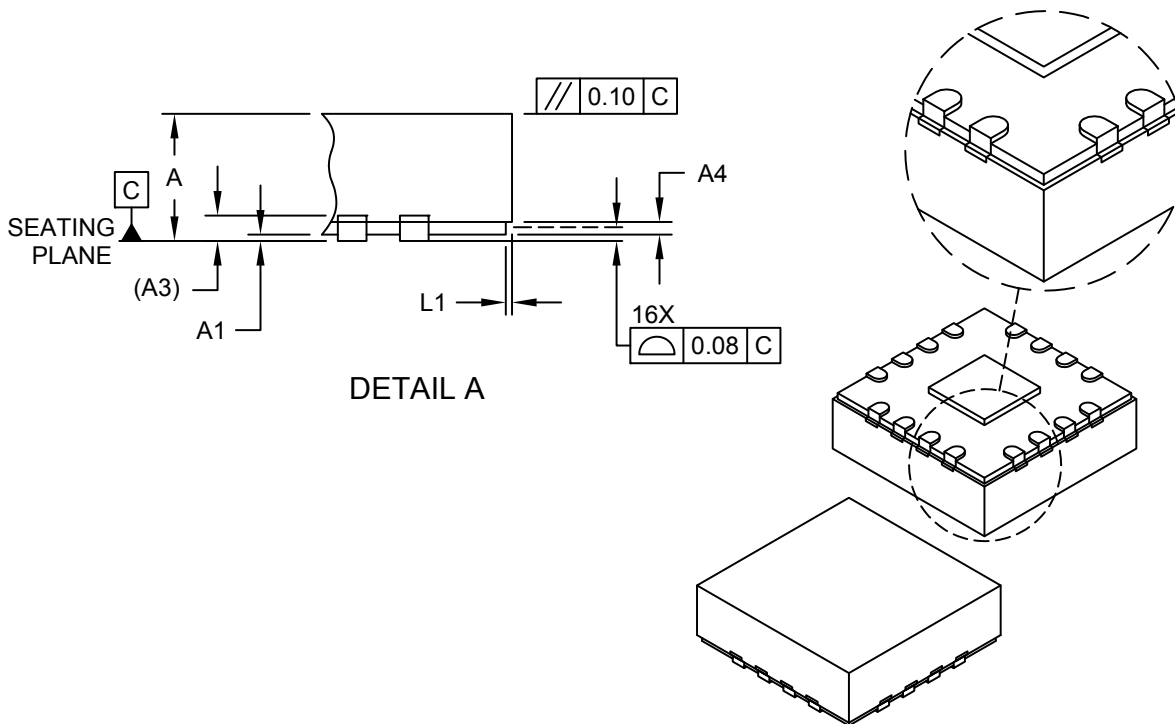

Dimension Limits	Units	MILLIMETERS		
		MIN	NOM	MAX
Number of Terminals	N	16		
Pitch	e	0.50 BSC		
Overall Height	A	0.80	0.90	1.00
Standoff	A1	0.00	0.02	0.05
Terminal Thickness	A3	0.20 REF		
Step Height	A4	0.05	0.12	0.19
Overall Width	E	3.00 BSC		
Exposed Pad Width	E2	1.00	1.10	1.50
Overall Length	D	3.00 BSC		
Exposed Pad Length	D2	1.00	1.10	1.50
Terminal Width	b	0.18	0.25	0.30
Terminal Length	L	0.25	0.35	0.45
Step Length	L1	0.035	0.060	0.085
Terminal-to-Exposed Pad	K	0.20	-	-

**Notes:**

- Pin 1 visual index feature may vary, but must be located within the hatched area.
- Package is saw singulated
- Dimensioning and tolerancing per ASME Y14.5M
  - BSC: Basic Dimension. Theoretically exact value shown without tolerances.
  - REF: Reference Dimension, usually without tolerance, for information purposes only.

---



---

## Footprint Outlines and Dimensions

---



---

### 16-Lead Plastic Quad Flat, No Lead Package (8N) - 3x3x1.0 mm Body [VQFN] Wettable Flanks (Stepped), 0.35 mm Terminal Length

**Note:** For the most current package drawings, please see the Microchip Packaging Specification located at <http://www.microchip.com/packaging>

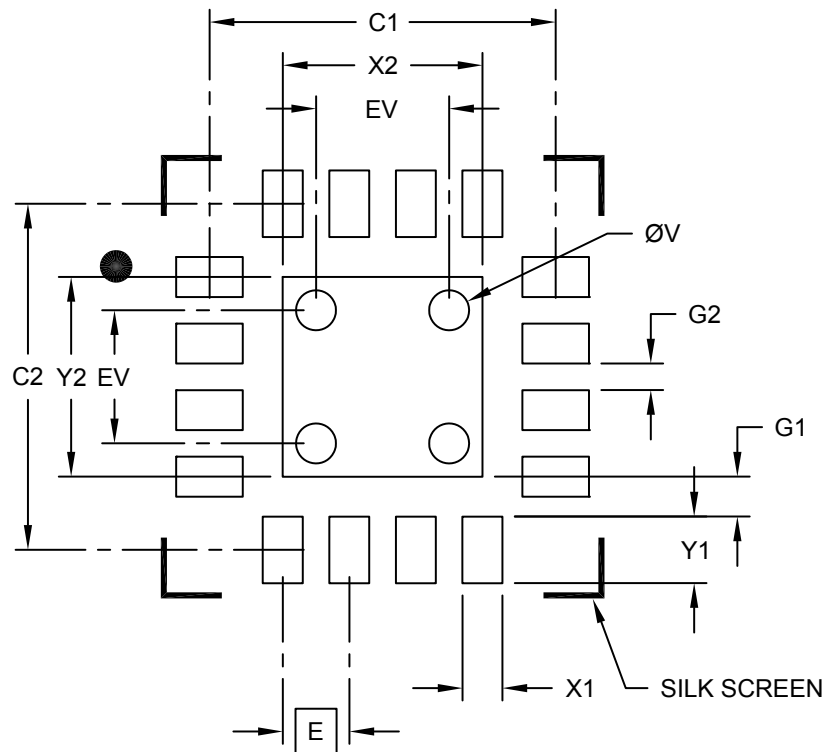

**RECOMMENDED LAND PATTERN**

Dimension Limits	Units	MILLIMETERS		
		MIN	NOM	MAX
Contact Pitch	E	0.50 BSC		
Optional Center Pad Width	X2			1.50
Optional Center Pad Length	Y2			1.50
Contact Pad Spacing	C1		2.60	
Contact Pad Spacing	C2		2.60	
Contact Pad Width (X16)	X1			0.30
Contact Pad Length (X16)	Y1			0.50
Contact Pad to Center Pad (X16)	G1	0.30		
Contact Pad to Contact Pad (X12)	G2	0.20		
Thermal Via Diameter	V		0.30	
Thermal Via Pitch	EV		1.00	

**Notes:**

- Dimensioning and tolerancing per ASME Y14.5M  
BSC: Basic Dimension. Theoretically exact value shown without tolerances.
- For best soldering results, thermal vias, if used, should be filled or tented to avoid solder loss during reflow process

**Package Outlines and Dimensions**

**16-Lead Plastic Quad Flat, No Lead Package (7N) - 4x4x1.0 mm Body [VQFN]  
Wettable Flanks (Stepped), 0.40 mm Terminal Length**

**Note:** For the most current package drawings, please see the Microchip Packaging Specification located at <http://www.microchip.com/packaging>

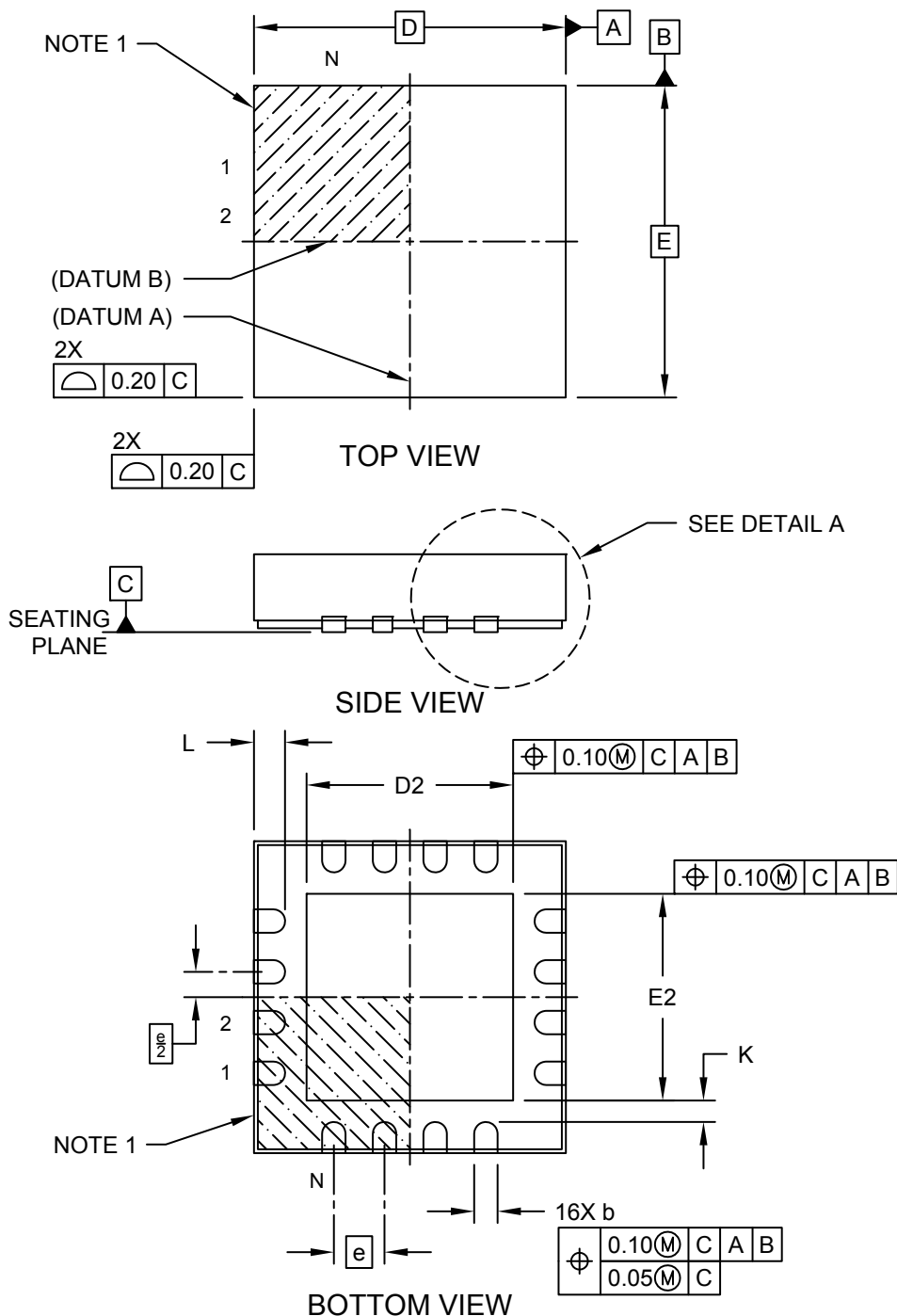



---



---

## Package Outlines and Dimensions

---



---

### 16-Lead Plastic Quad Flat, No Lead Package (7N) - 4x4x1.0 mm Body [VQFN] Wettable Flanks (Stepped), 0.40 mm Terminal Length

**Note:** For the most current package drawings, please see the Microchip Packaging Specification located at <http://www.microchip.com/packaging>

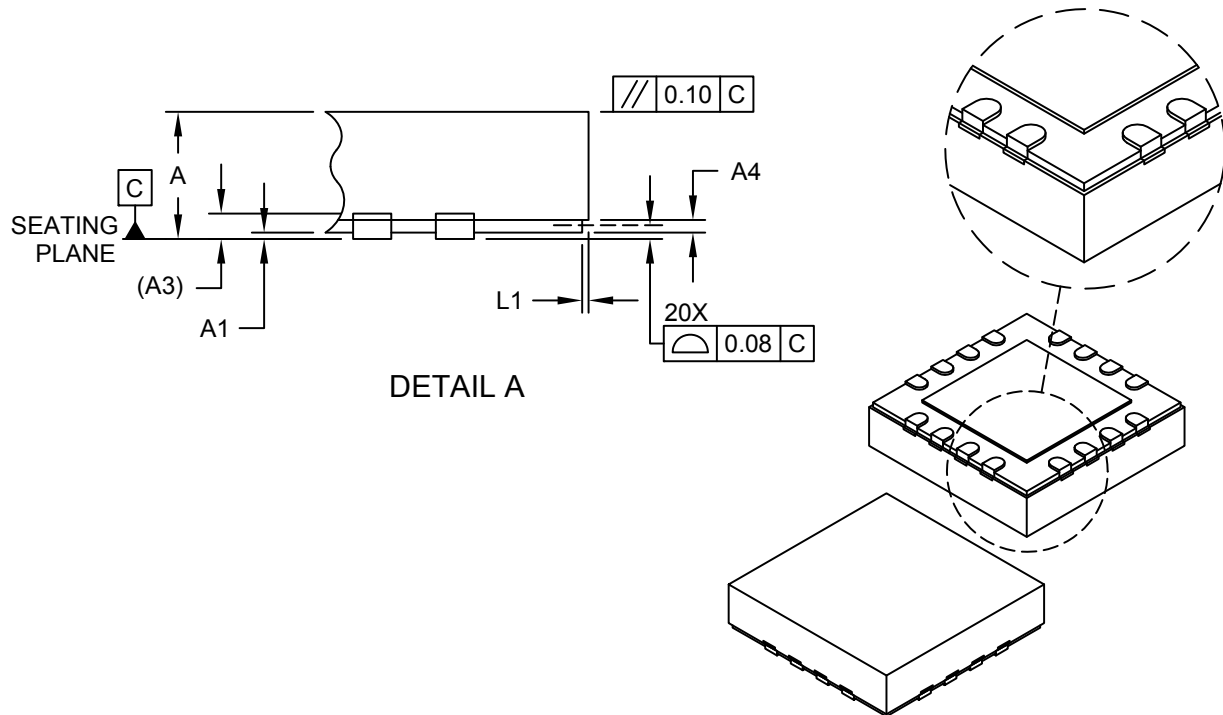

Dimension Limits	Units	MILLIMETERS		
		MIN	NOM	MAX
Number of Terminals	N	16		
Pitch	e	0.65 BSC		
Overall Height	A	0.80	0.90	1.00
Standoff	A1	0.00	0.02	0.05
Terminal Thickness	A3	0.20 REF		
Step Height	A4	0.05	0.12	0.19
Overall Width	E	4.00 BSC		
Exposed Pad Width	E2	2.50	2.65	2.80
Overall Length	D	4.00 BSC		
Exposed Pad Length	D2	2.50	2.65	2.80
Terminal Width	b	0.25	0.30	0.35
Terminal Length	L	0.30	0.40	0.50
Step Length	L1	0.035	0.060	0.085
Terminal-to-Exposed Pad	K	0.20	-	-

**Notes:**

1. Pin 1 visual index feature may vary, but must be located within the hatched area.
2. Package is saw singulated
3. Dimensioning and tolerancing per ASME Y14.5M
  - BSC: Basic Dimension. Theoretically exact value shown without tolerances.
  - REF: Reference Dimension, usually without tolerance, for information purposes only.

**Footprint Outlines and Dimensions**

**16-Lead Plastic Quad Flat, No Lead Package (7N) - 4x4x1.0 mm Body [VQFN]  
Wettable Flanks (Stepped), 0.40 mm Terminal Length**

**Note:** For the most current package drawings, please see the Microchip Packaging Specification located at <http://www.microchip.com/packaging>

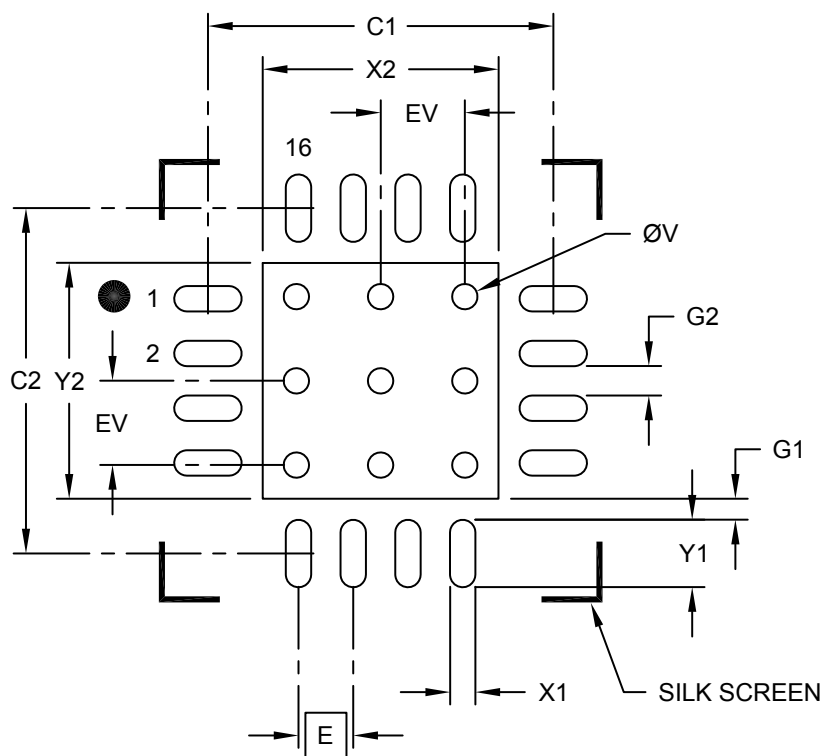

**RECOMMENDED LAND PATTERN**

Dimension Limits	Units	MILLIMETERS		
		MIN	NOM	MAX
Contact Pitch	E	0.65 BSC		
Optional Center Pad Width	X2			2.80
Optional Center Pad Length	Y2			2.80
Contact Pad Spacing	C1	4.10		
Contact Pad Spacing	C2	4.10		
Contact Pad Width (X16)	X1			0.30
Contact Pad Length (X16)	Y1			0.80
Contact Pad to Center Pad (X16)	G1	0.25		
Contact Pad to Contact Pad (X12)	G2	0.35		
Thermal Via Diameter	V	0.30		
Thermal Via Pitch	EV	1.00		

**Notes:**

1. Dimensioning and tolerancing per ASME Y14.5M  
BSC: Basic Dimension. Theoretically exact value shown without tolerances.
2. For best soldering results, thermal vias, if used, should be filled or tented to avoid solder loss during reflow process

**Package Outlines and Dimensions**

**20-Lead Very Thin Plastic Quad Flat, No Lead Package (LXX) - 3x3x0.9 mm Body [VQFN] Internal Flip Chip, No Exposed Pad**

**Note:** For the most current package drawings, please see the Microchip Packaging Specification located at <http://www.microchip.com/packaging>

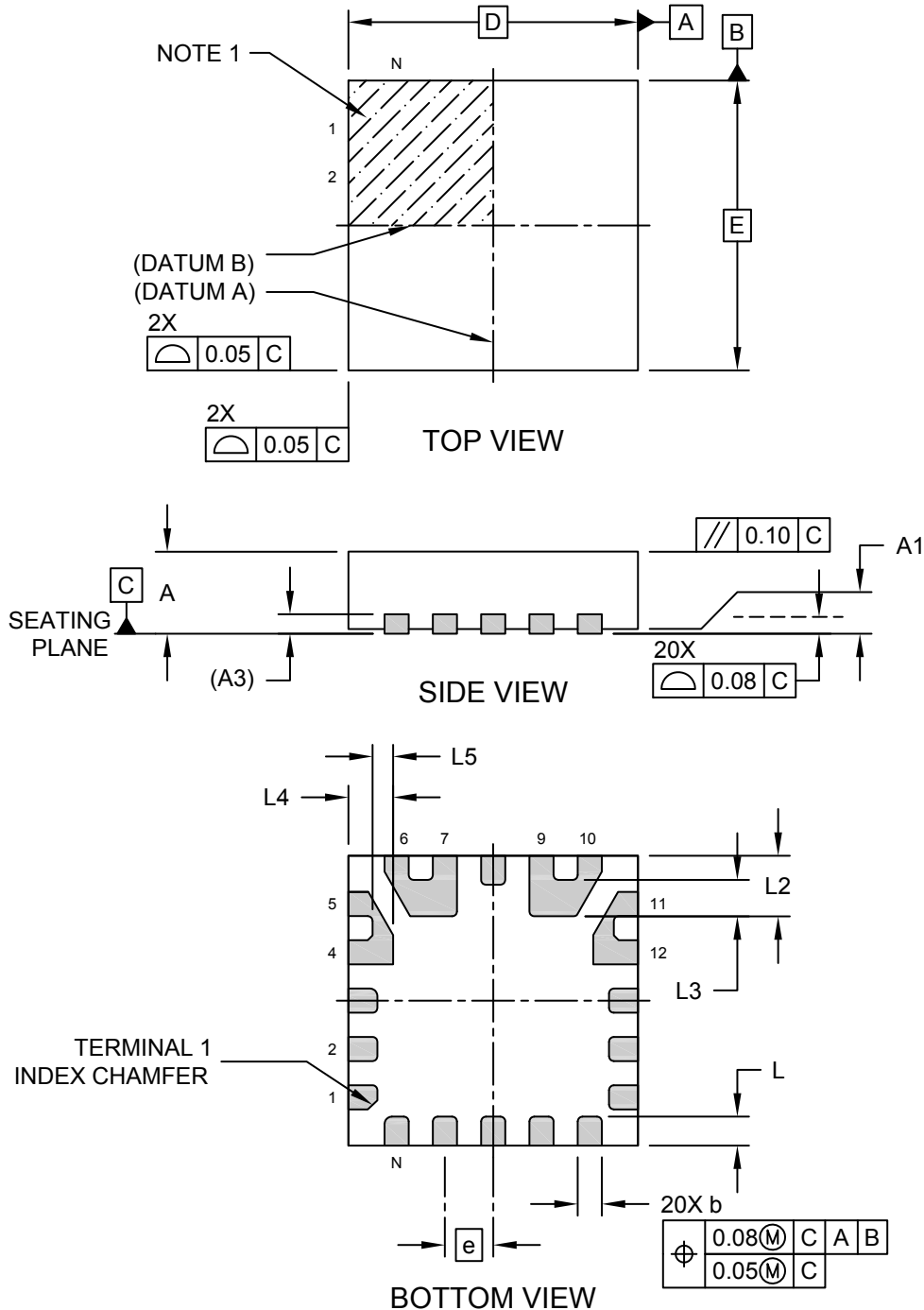

**Package Outlines and Dimensions**

**20-Lead Very Thin Plastic Quad Flat, No Lead Package (LXX) - 3x3x0.9 mm Body [VQFN]  
Internal Flip Chip, No Exposed Pad**

**Note:** For the most current package drawings, please see the Microchip Packaging Specification located at <http://www.microchip.com/packaging>

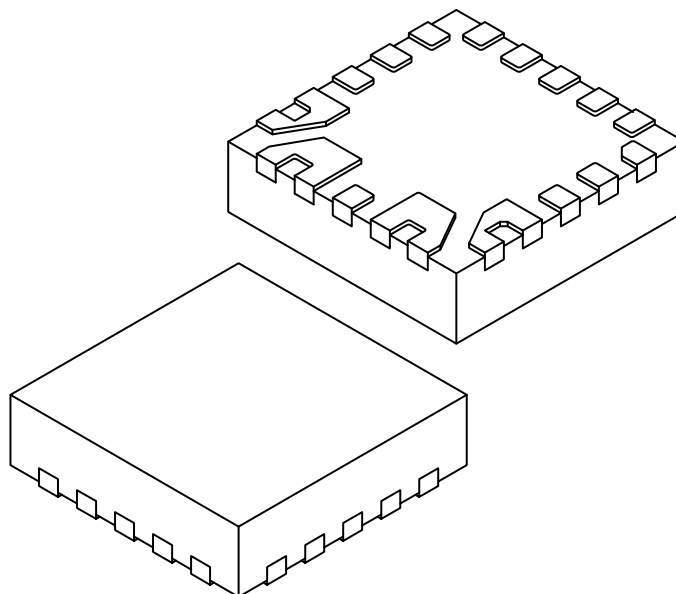

Dimension Limits	Units	MILLIMETERS		
		MIN	NOM	MAX
Number of Terminals	N	20		
Pitch	e	0.50 BSC		
Overall Height	A	0.80	0.85	0.90
Standoff	A1	0.00	0.02	0.05
Terminal Thickness	A3	0.203 REF		
Overall Length	D	3.00 BSC		
Overall Width	E	3.00 BSC		
Terminal Length	L	0.25	0.30	0.35
Terminal Length	L2	0.58	0.63	0.68
Terminal Length	L3	0.33	0.38	0.43
Terminal Length	L4	0.41	0.46	0.51
Terminal Length	L5	0.16	0.21	0.26
Terminal Width	b	0.20	0.25	0.30

**Notes:**

1. Pin 1 visual index feature may vary, but must be located within the hatched area.
2. Package is saw singulated
3. Dimensioning and tolerancing per ASME Y14.5M

BSC: Basic Dimension. Theoretically exact value shown without tolerances.

REF: Reference Dimension, usually without tolerance, for information purposes only.

---



---

## Footprint Outlines and Dimensions

---



---

### 20-Lead Very Thin Plastic Quad Flat, No Lead Package (LXX) - 3x3x0.9 mm Body [VQFN] Internal Flip Chip, No Exposed Pad

**Note:** For the most current package drawings, please see the Microchip Packaging Specification located at <http://www.microchip.com/packaging>

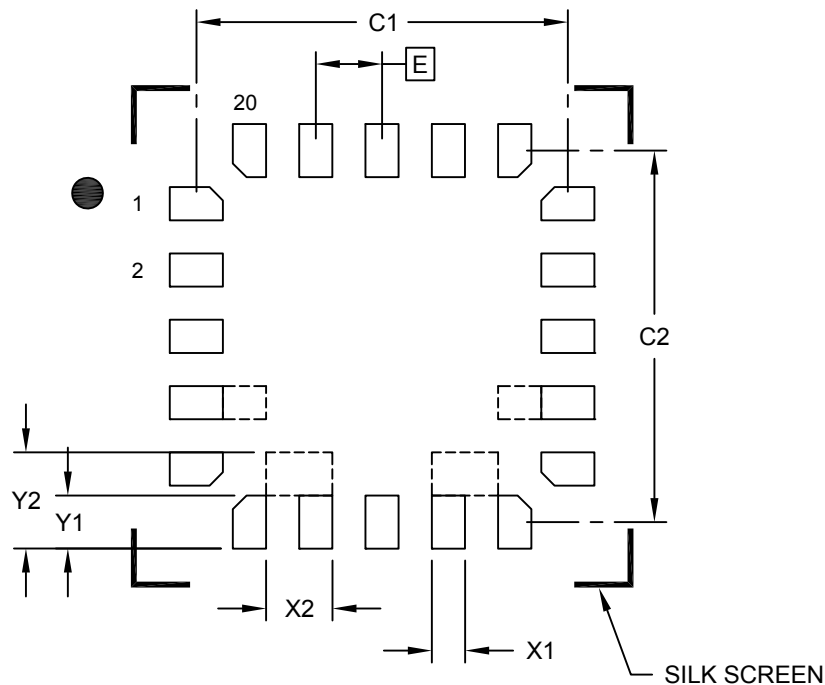

### RECOMMENDED LAND PATTERN

Dimension Limits	Units	MILLIMETERS		
		MIN	NOM	MAX
Contact Pitch	E	0.50 BSC		
Contact Pad Spacing	C1		2.80	
Contact Pad Spacing	C2		2.80	
Contact Pad Width (X20)	X1			0.27
Contact Pad Length (X20)	Y1			0.42
Optional Extended Pad Width (X2)	X2			0.52
Optional Extended Pad Length (X4)	Y2			0.75

**Notes:**

1. Dimensioning and tolerancing per ASME Y14.5M

BSC: Basic Dimension. Theoretically exact value shown without tolerances.

Microchip Technology Drawing C04-2421A

**Package Outlines and Dimensions**

**20-Lead Plastic Quad Flat, No Lead Package (6N) - 4x4x1.0 mm Body [VQFN]  
Wettable Flanks (Stepped), 0.40 mm Terminal Length**

**Note:** For the most current package drawings, please see the Microchip Packaging Specification located at <http://www.microchip.com/packaging>

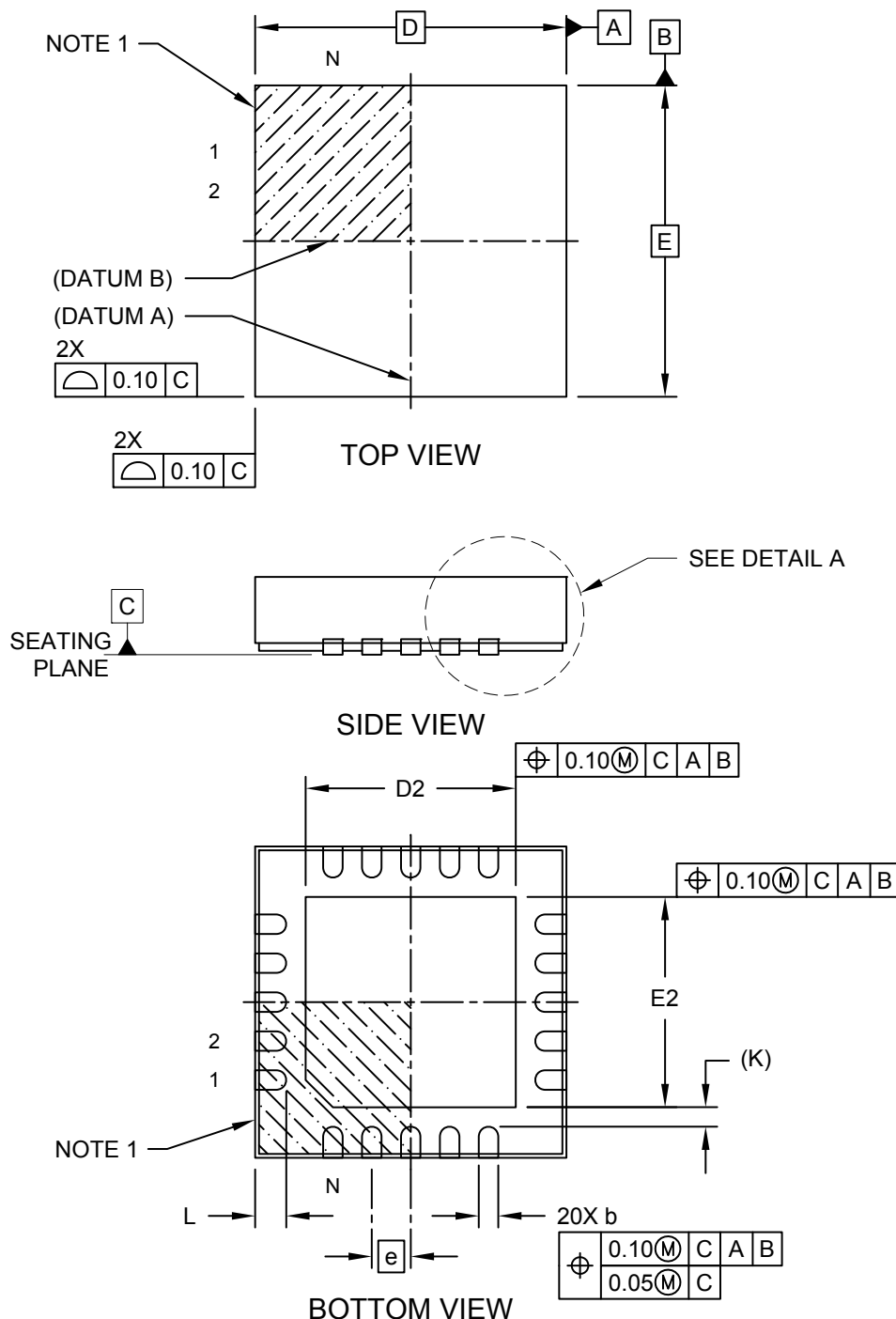

---



---

## Package Outlines and Dimensions

---



---

### 20-Lead Plastic Quad Flat, No Lead Package (6N) - 4x4x1.0 mm Body [VQFN] Wettable Flanks (Stepped), 0.40 mm Terminal Length

**Note:** For the most current package drawings, please see the Microchip Packaging Specification located at <http://www.microchip.com/packaging>

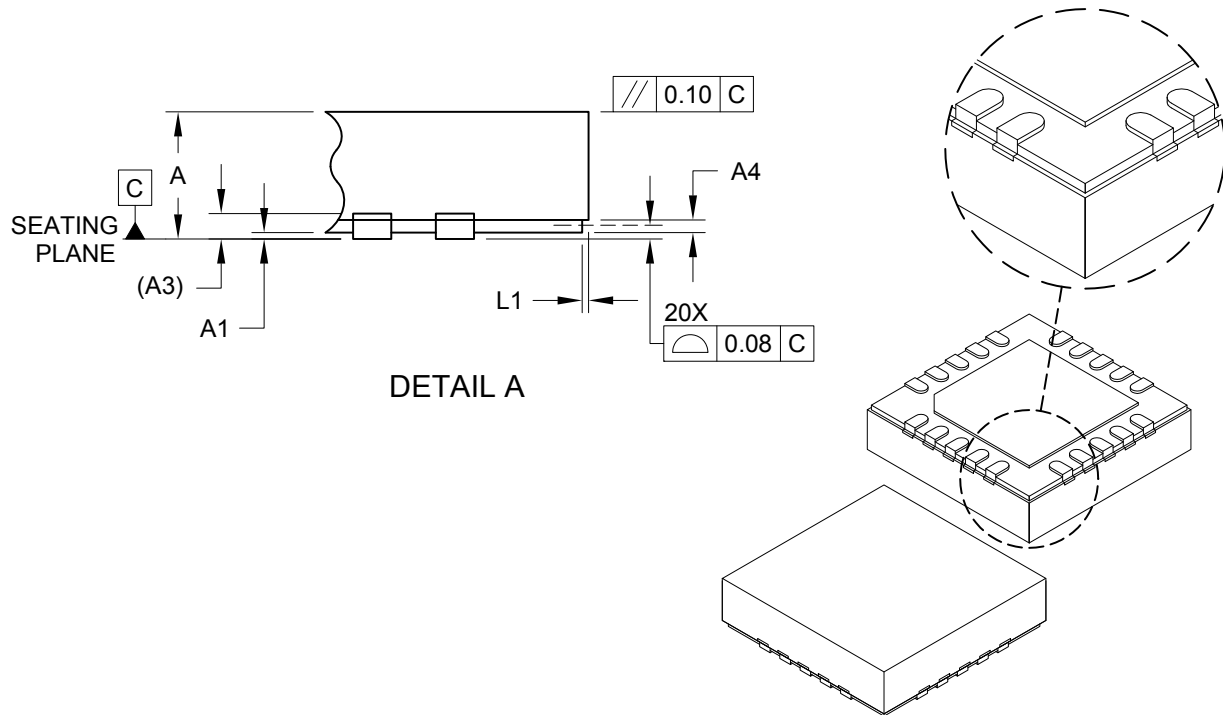

Dimension Limits	Units	MILLIMETERS		
		MIN	NOM	MAX
Number of Terminals	N	20		
Pitch	e	0.50 BSC		
Overall Height	A	0.80	0.90	1.00
Standoff	A1	0.00	0.02	0.05
Terminal Thickness	A3	0.20 REF		
Step Height	A4	0.05	0.12	0.19
Overall Width	E	4.00 BSC		
Exposed Pad Width	E2	2.60	2.70	2.80
Overall Length	D	4.00 BSC		
Exposed Pad Length	D2	2.60	2.70	2.80
Terminal Width	b	0.20	0.25	0.30
Terminal Length	L	0.30	0.40	0.50
Step Length	L1	0.035	0.060	0.085
Terminal-to-Exposed Pad	K	0.25 REF		

**Notes:**

1. Pin 1 visual index feature may vary, but must be located within the hatched area.
2. Package is saw singulated
3. Dimensioning and tolerancing per ASME Y14.5M
  - BSC: Basic Dimension. Theoretically exact value shown without tolerances.
  - REF: Reference Dimension, usually without tolerance, for information purposes only.

**Footprint Outlines and Dimensions**

**20-Lead Plastic Quad Flat, No Lead Package (6N) - 4x4x1.0 mm Body [VQFN]  
Wettable Flanks (Stepped), 0.40 mm Terminal Length**

**Note:** For the most current package drawings, please see the Microchip Packaging Specification located at <http://www.microchip.com/packaging>

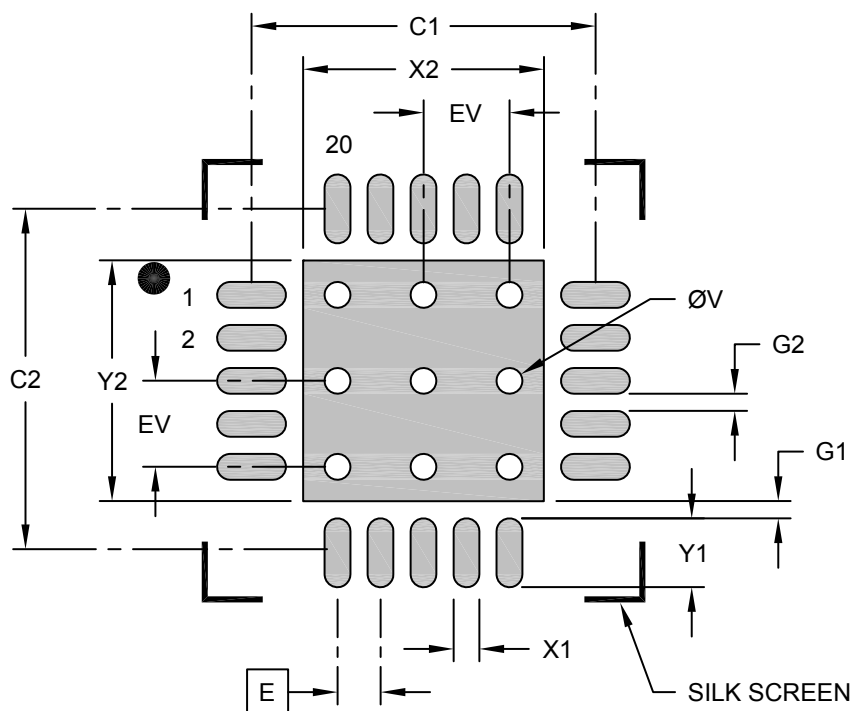

**RECOMMENDED LAND PATTERN**

Dimension Limits	Units	MILLIMETERS		
		MIN	NOM	MAX
Contact Pitch	E	0.50 BSC		
Optional Center Pad Width	X2			2.80
Optional Center Pad Length	Y2			2.80
Contact Pad Spacing	C1		4.00	
Contact Pad Spacing	C2		4.00	
Contact Pad Width (X20)	X1			0.30
Contact Pad Length (X20)	Y1			0.80
Contact Pad to Center Pad (X20)	G1	0.25		
Contact Pad to Contact Pad (X16)	G2	0.20		
Thermal Via Diameter	V		0.30	
Thermal Via Pitch	EV		1.00	

**Notes:**

1. Dimensioning and tolerancing per ASME Y14.5M  
BSC: Basic Dimension. Theoretically exact value shown without tolerances.
2. For best soldering results, thermal vias, if used, should be filled or tented to avoid solder loss during reflow process



**Package Outlines and Dimensions**

**20-Lead Plastic Quad Flat, No Lead Package (ML) – 5x5x1.0 mm Body [VQFN]  
With 0.40 mm Contact Length**

**Note:** For the most current package drawings, please see the Microchip Packaging Specification located at <http://www.microchip.com/packaging>

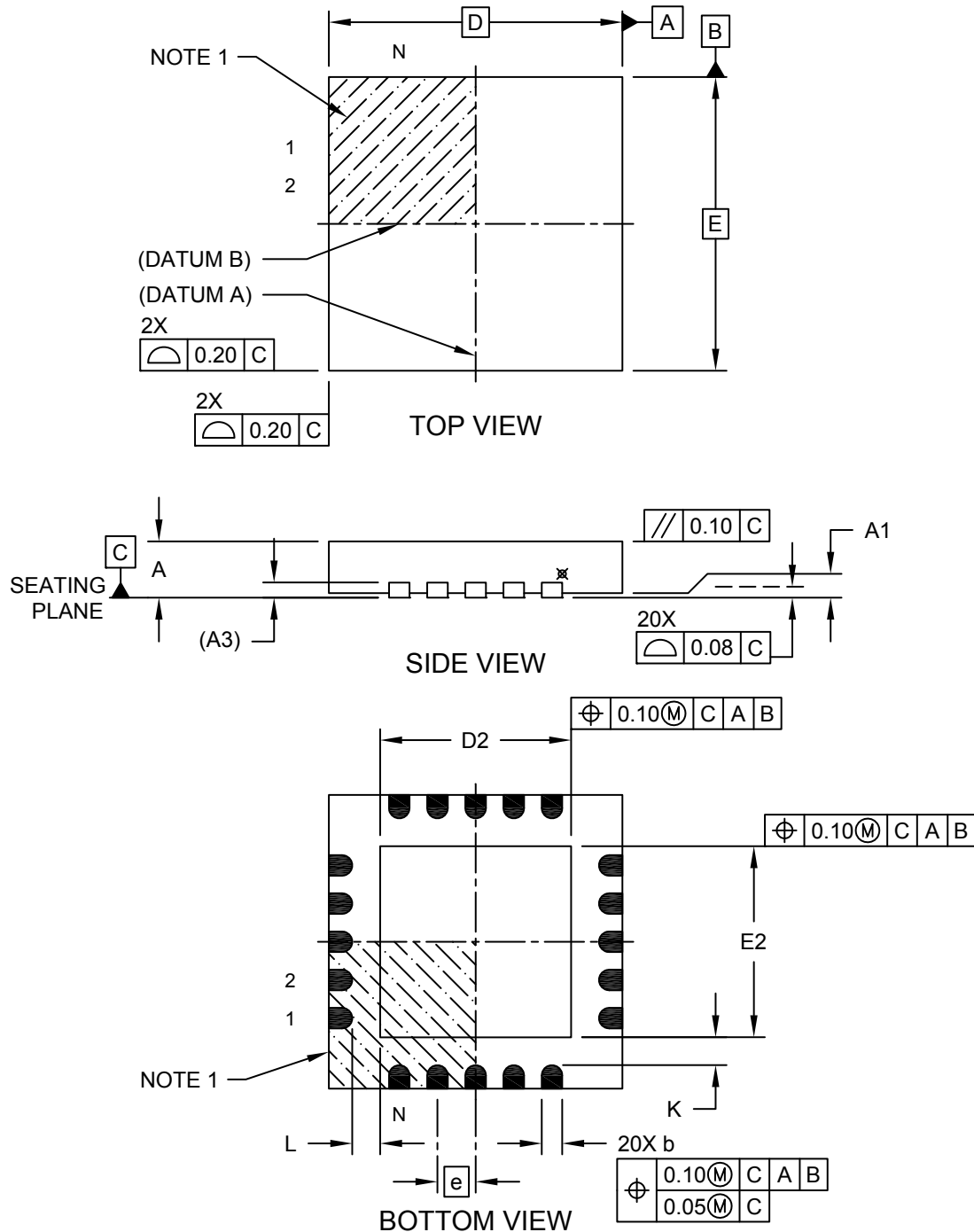

**Package Outlines and Dimensions**

**20-Lead Plastic Quad Flat, No Lead Package (ML) – 5x5x1.0 mm Body [VQFN]  
With 0.40 mm Contact Length**

**Note:** For the most current package drawings, please see the Microchip Packaging Specification located at <http://www.microchip.com/packaging>

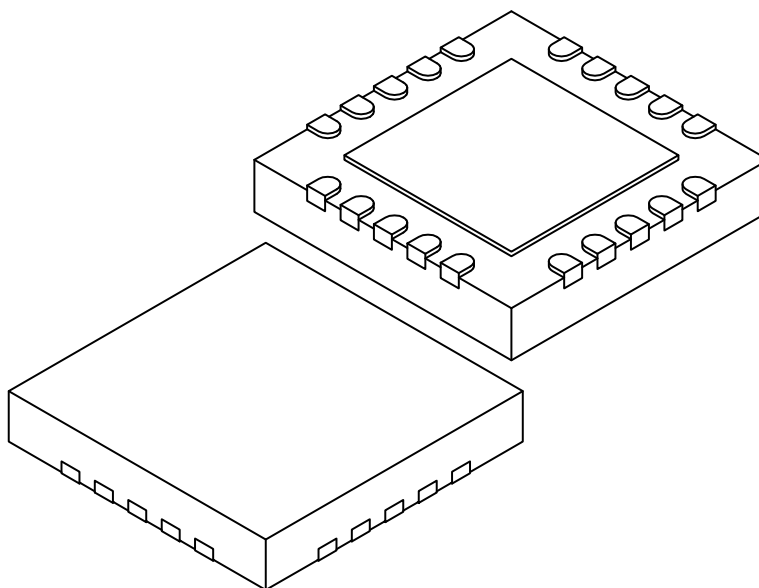

Dimension Limits	Units	MILLIMETERS		
		MIN	NOM	MAX
Number of Terminals	N	20		
Pitch	e	0.65 BSC		
Overall Height	A	0.80	0.90	1.00
Standoff	A1	0.00	0.02	0.05
Contact Thickness	(A3)	0.20 REF		
Overall Length	D	5.00 BSC		
Exposed Pad Length	D2	3.15	3.25	3.35
Overall Width	E	5.00 BSC		
Exposed Pad Width	E2	3.15	3.25	3.35
Contact Width	b	0.25	0.30	0.35
Contact Length	L	0.35	0.40	0.45
Contact-to-Exposed Pad	K	0.20	-	-

**Notes:**

- Pin 1 visual index feature may vary, but must be located within the hatched area.
- Package is saw singulated
- Dimensioning and tolerancing per ASME Y14.5M
  - BSC: Basic Dimension. Theoretically exact value shown without tolerances.
  - REF: Reference Dimension, usually without tolerance, for information purposes only.

---



---

## Footprint Outlines and Dimensions

---



---

### 20-Lead Plastic Quad Flat, No Lead Package (ML) – 5x5x1.0 mm Body [VQFN] With 0.40 mm Contact Length

**Note:** For the most current package drawings, please see the Microchip Packaging Specification located at <http://www.microchip.com/packaging>

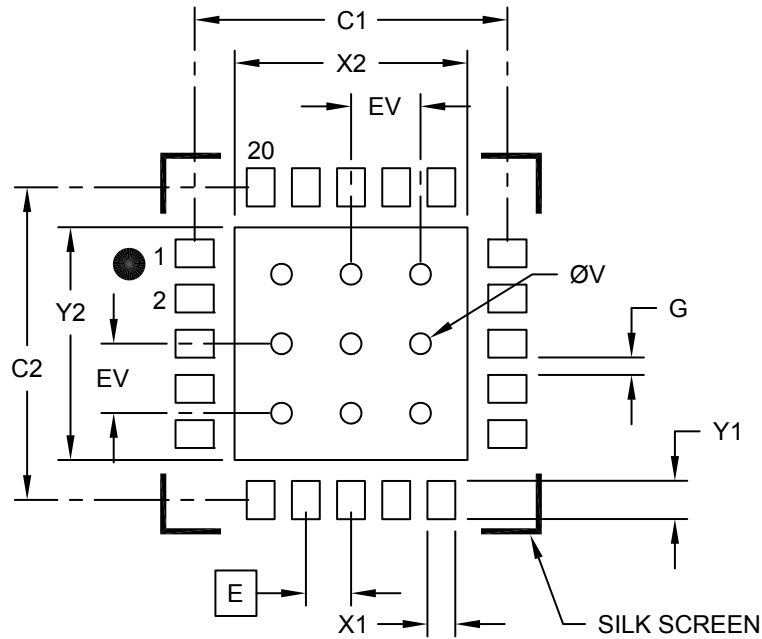

### RECOMMENDED LAND PATTERN

Dimension Limits	Units	MILLIMETERS		
		MIN	NOM	MAX
Contact Pitch	E	0.65 BSC		
Optional Center Pad Width	W2			3.35
Optional Center Pad Length	T2			3.35
Contact Pad Spacing	C1		4.50	
Contact Pad Spacing	C2		4.50	
Contact Pad Width (X20)	X1			0.40
Contact Pad Length (X20)	Y1			0.55
Distance Between Pads	G	0.20		
Thermal Via Diameter	V		0.30	
Thermal Via Pitch	EV		1.00	

**Notes:**

1. Dimensioning and tolerancing per ASME Y14.5M  
BSC: Basic Dimension. Theoretically exact value shown without tolerances.
2. For best soldering results, thermal vias, if used, should be filled or tented to avoid solder loss during reflow process

**Package Outlines and Dimensions**

**20-Lead Plastic Quad Flat, No Lead Package (MQ) – 5x5x1.0 mm Body [VQFN]  
With 0.40 mm Contact Length**

**Note:** For the most current package drawings, please see the Microchip Packaging Specification located at <http://www.microchip.com/packaging>

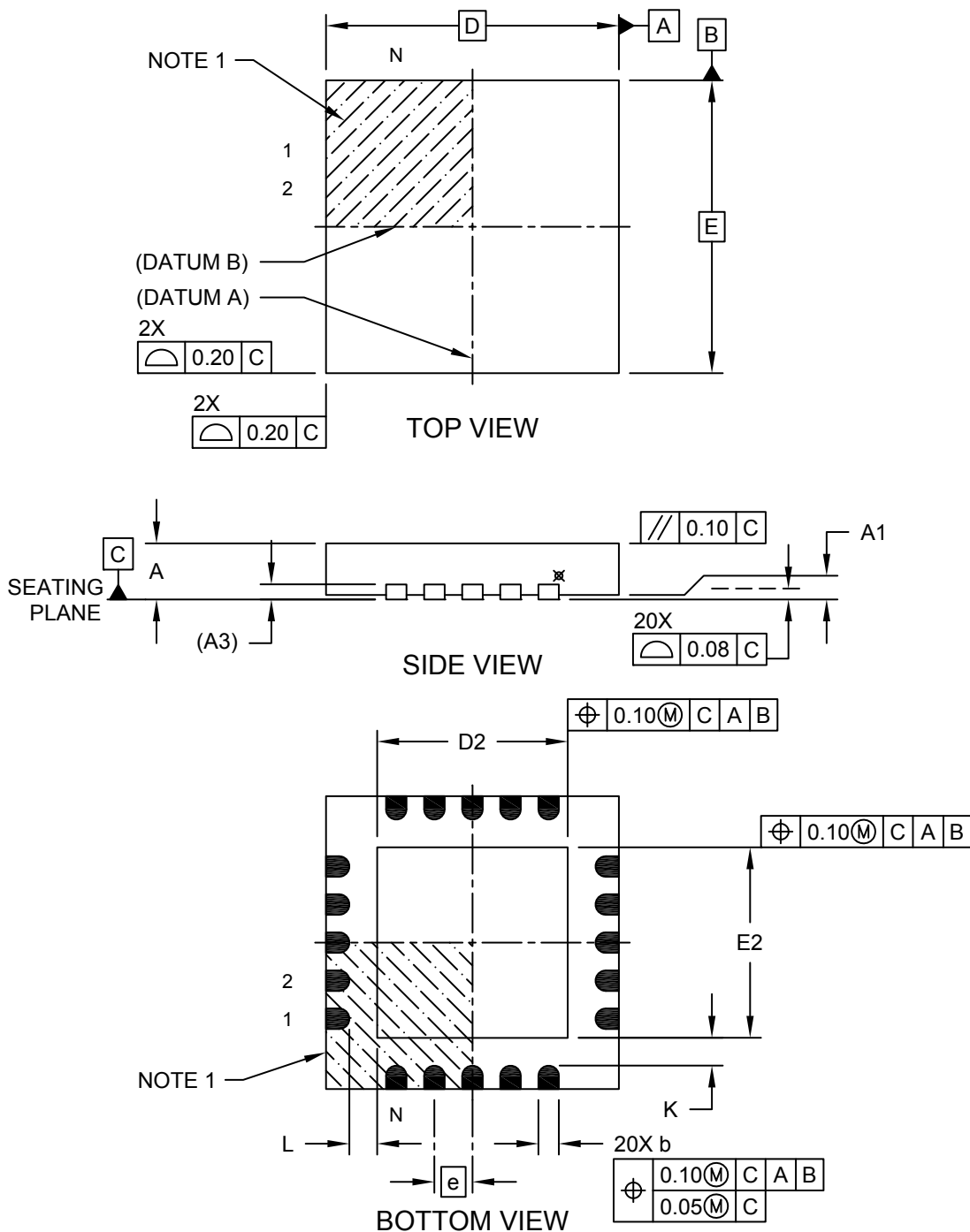

---



---

## Package Outlines and Dimensions

---



---

### 20-Lead Plastic Quad Flat, No Lead Package (MQ) – 5x5x1.0 mm Body [VQFN] With 0.40 mm Contact Length

**Note:** For the most current package drawings, please see the Microchip Packaging Specification located at <http://www.microchip.com/packaging>

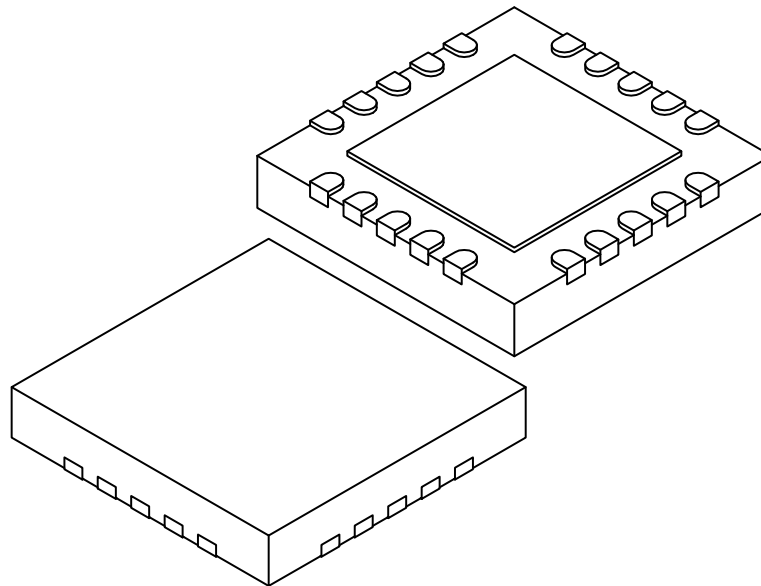

Dimension Limits	Units	MILLIMETERS		
		MIN	NOM	MAX
Number of Terminals	N	20		
Pitch	e	0.65 BSC		
Overall Height	A	0.80	0.90	1.00
Standoff	A1	0.00	0.02	0.05
Contact Thickness	(A3)	0.20 REF		
Overall Length	D	5.00 BSC		
Exposed Pad Length	D2	3.15	3.25	3.35
Overall Width	E	5.00 BSC		
Exposed Pad Width	E2	3.15	3.25	3.35
Contact Width	b	0.25	0.30	0.35
Contact Length	L	0.35	0.40	0.45
Contact-to-Exposed Pad	K	0.20	-	-

**Notes:**

1. Pin 1 visual index feature may vary, but must be located within the hatched area.
2. Package is saw singulated
3. Dimensioning and tolerancing per ASME Y14.5M
  - BSC: Basic Dimension. Theoretically exact value shown without tolerances.
  - REF: Reference Dimension, usually without tolerance, for information purposes only.

**Footprint Outlines and Dimensions**

**20-Lead Plastic Quad Flat, No Lead Package (MQ) – 5x5x1.0 mm Body [VQFN]  
With 0.40 mm Contact Length**

**Note:** For the most current package drawings, please see the Microchip Packaging Specification located at <http://www.microchip.com/packaging>

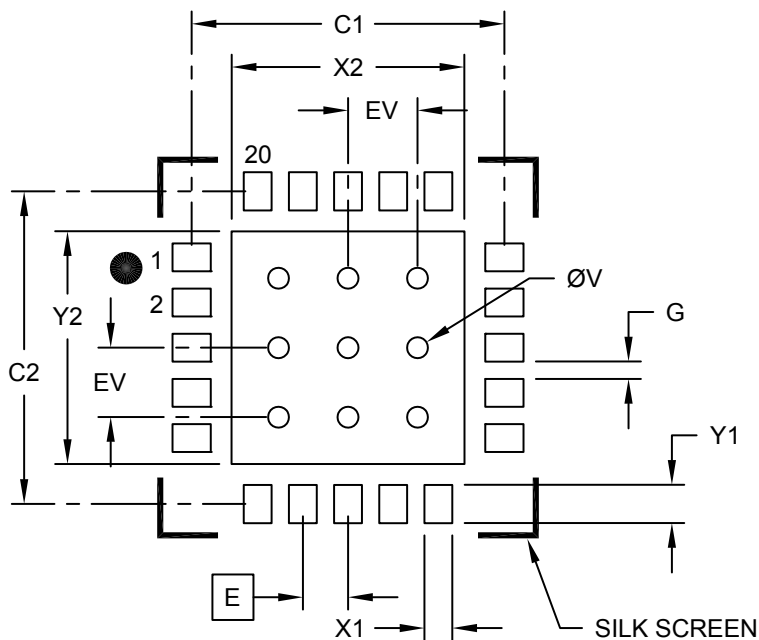

**RECOMMENDED LAND PATTERN**

Dimension Limits	Units	MILLIMETERS		
		MIN	NOM	MAX
Contact Pitch	E	0.65 BSC		
Optional Center Pad Width	W2			3.35
Optional Center Pad Length	T2			3.35
Contact Pad Spacing	C1		4.50	
Contact Pad Spacing	C2		4.50	
Contact Pad Width (X20)	X1			0.40
Contact Pad Length (X20)	Y1			0.55
Distance Between Pads	G	0.20		
Thermal Via Diameter	V		0.30	
Thermal Via Pitch	EV		1.00	

**Notes:**

1. Dimensioning and tolerancing per ASME Y14.5M  
BSC: Basic Dimension. Theoretically exact value shown without tolerances.
2. For best soldering results, thermal vias, if used, should be filled or tented to avoid solder loss during reflow process

**Package Outlines and Dimensions**

**24-Lead Very Thin Plastic Quad Flat, No Lead Package (NVA) - 3x4 mm Body [VQFN]  
With Multiple Exposed Pads and Wettable Flanks**

**Note:** For the most current package drawings, please see the Microchip Packaging Specification located at <http://www.microchip.com/packaging>

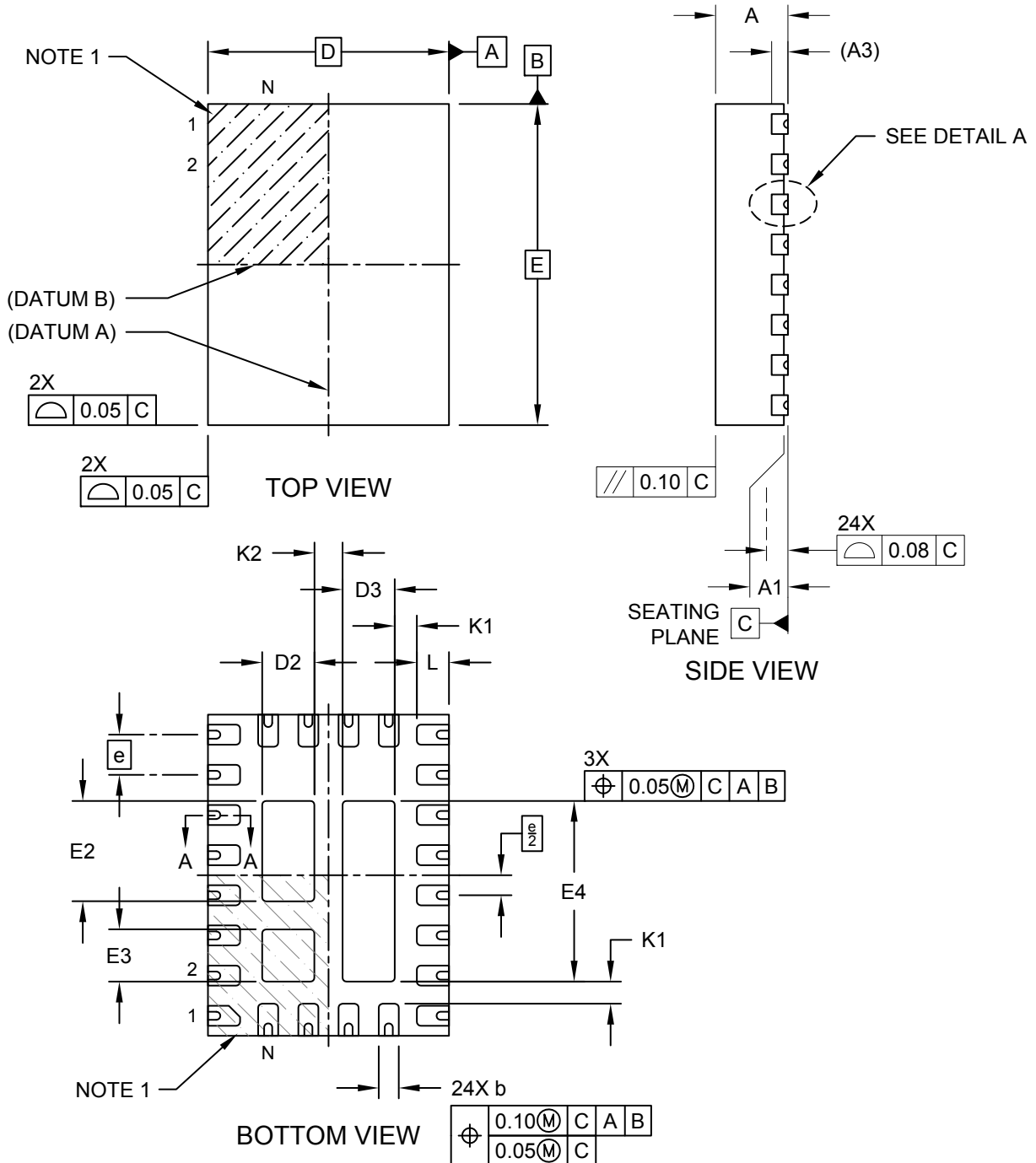

**Package Outlines and Dimensions**

**24-Lead Very Thin Plastic Quad Flat, No Lead Package (NVA) - 3x4 mm Body [VQFN]  
With Multiple Exposed Pads and Wettable Flanks**

**Note:** For the most current package drawings, please see the Microchip Packaging Specification located at <http://www.microchip.com/packaging>

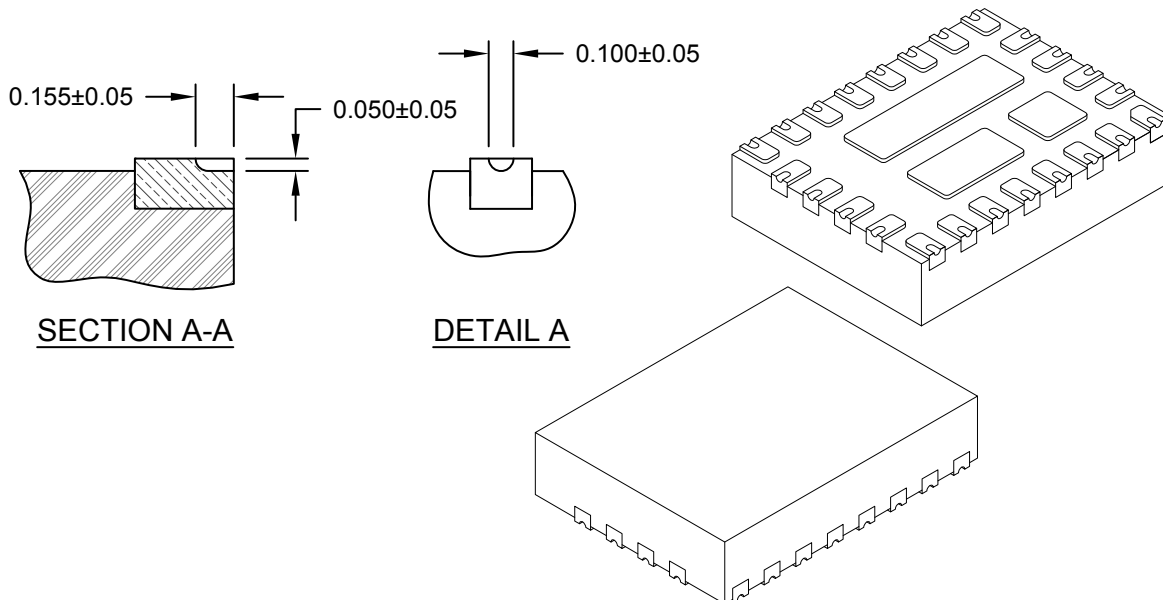

		MILLIMETERS		
Units		MIN	NOM	MAX
Dimension Limits				
Number of Terminals	N	24		
Pitch	e	0.50 BSC		
Overall Height	A	0.80	0.85	0.90
Standoff	A1	0.00	0.02	0.05
Terminal Thickness	A3	0.203 REF		
Overall Length	D	3.00 BSC		
Exposed Pad Width	D2	0.60	0.65	0.70
Exposed Pad Width	D3	0.60	0.65	0.70
Overall Width	E	4.00 BSC		
Exposed Pad Length	E2	1.15	1.25	1.35
Exposed Pad Length	E3	0.55	0.65	0.75
Exposed Pad Length	E4	1.75	2.25	2.75
Terminal Width	b	0.20	0.25	0.30
Terminal Length	L	0.30	0.40	0.45
Terminal-to-Exposed-Pad	K1	0.20	-	-
Terminal-to-Exposed-Pad	K2	0.30	-	-

**Notes:**

1. Pin 1 visual index feature may vary, but must be located within the hatched area.
2. Package is saw singulated
3. Dimensioning and tolerancing per ASME Y14.5M

BSC: Basic Dimension. Theoretically exact value shown without tolerances.

REF: Reference Dimension, usually without tolerance, for information purposes only.



---



---

## Footprint Outlines and Dimensions

---



---

### 24-Lead Very Thin Plastic Quad Flat, No Lead Package (NVA) - 3x4 mm Body [VQFN] With Multiple Exposed Pads

**Note:** For the most current package drawings, please see the Microchip Packaging Specification located at <http://www.microchip.com/packaging>

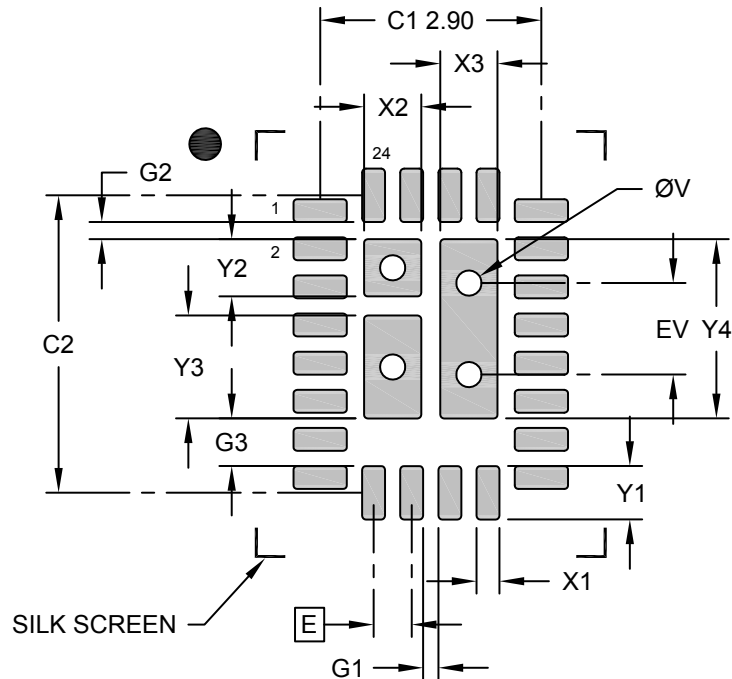

**RECOMMENDED LAND PATTERN**

Dimension Limits	Units	MILLIMETERS		
		MIN	NOM	MAX
Contact Pitch	E	0.50 BSC		
Contact Pad Spacing	C1		2.90	
Contact Pad Spacing	C2		3.90	
Contact Pad Width (X24)	X1			0.30
Contact Pad Length (X24)	Y1			0.70
Center Pad Width	X2			0.75
Center Pad Width (X2)	X3			0.75
Center Pad Length	Y2			0.75
Center Pad Length	Y3			1.35
Center Pad Length	Y4			2.35
Contact Pad to Center Pad (X24)	G1	0.20		
Contact Pad to Center Pad (X4)	G2	0.23		
Contact Pad to Center Pad (X4)	G3	0.63		
Thermal Via Diameter	V		0.33	
Thermal Via Pitch	EV		1.20	

**Notes:**

1. Dimensioning and tolerancing per ASME Y14.5M  
BSC: Basic Dimension. Theoretically exact value shown without tolerances.
2. For best soldering results, thermal vias, if used, should be filled or tented to avoid solder loss during reflow process

Microchip Technology Drawing C04-3212A

**Package Outlines and Dimensions**

**24-Lead Very Thin Plastic Quad Flat, No Lead Package (MJ) – 4x4x0.9 mm Body [VQFN]**

**Note:** For the most current package drawings, please see the Microchip Packaging Specification located at <http://www.microchip.com/packaging>

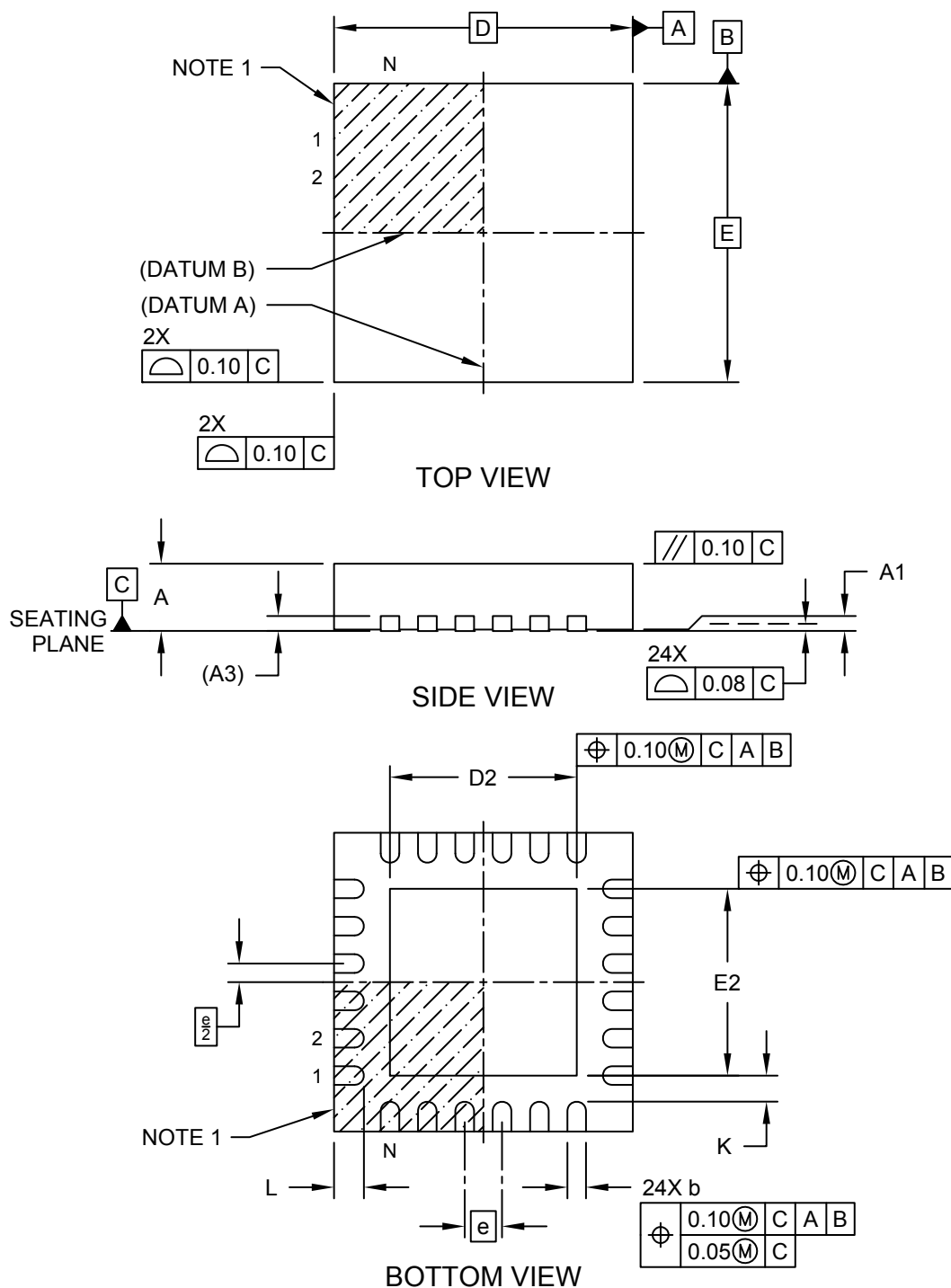

---



---

## Package Outlines and Dimensions

---



---

### 24-Lead Very Thin Plastic Quad Flat, No Lead Package (MJ) – 4x4x0.9 mm Body [VQFN]

**Note:** For the most current package drawings, please see the Microchip Packaging Specification located at <http://www.microchip.com/packaging>

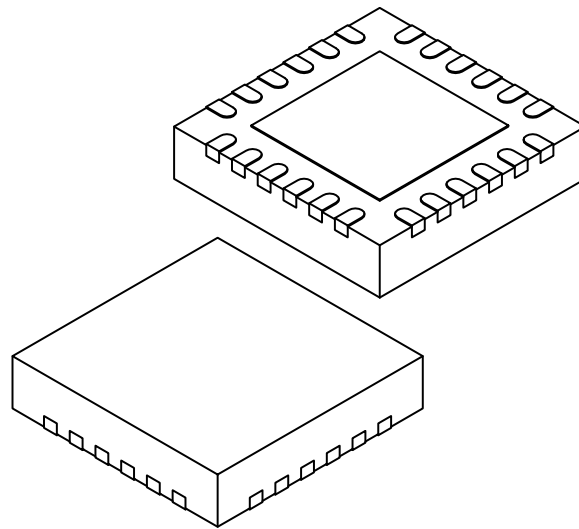

Dimension Limits	Units	MILLIMETERS		
		MIN	NOM	MAX
Number of Terminals	N	24		
Pitch	e	0.50 BSC		
Overall Height	A	0.80	0.85	0.90
Standoff	A1	0.00	0.02	0.05
Terminal Thickness	A3	0.20 REF		
Overall Width	E	4.00 BSC		
Exposed Pad Width	E2	2.40	2.50	2.60
Overall Length	D	4.00 BSC		
Exposed Pad Length	D2	2.40	2.50	2.60
Terminal Width	b	0.20	0.25	0.30
Terminal Length	L	0.30	0.40	0.50
Terminal-to-Exposed Pad	K	0.20	-	-

**Notes:**

1. Pin 1 visual index feature may vary, but must be located within the hatched area.
2. Package is saw singulated
3. Dimensioning and tolerancing per ASME Y14.5M

BSC: Basic Dimension. Theoretically exact value shown without tolerances.

REF: Reference Dimension, usually without tolerance, for information purposes only.

**Footprint Outlines and Dimensions**

**24-Lead Very Thin Plastic Quad Flat, No Lead Package (MJ) – 4x4x0.9 mm Body [VQFN]**

**Note:** For the most current package drawings, please see the Microchip Packaging Specification located at <http://www.microchip.com/packaging>

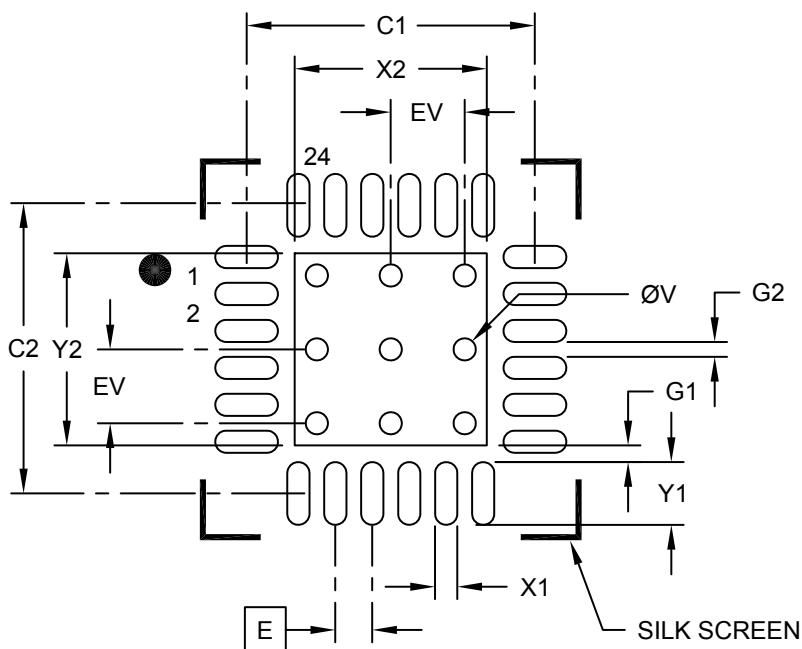

**RECOMMENDED LAND PATTERN**

Dimension Limits	Units	MILLIMETERS		
		MIN	NOM	MAX
Contact Pitch	E	0.50 BSC		
Optional Center Pad Width	X2			2.60
Optional Center Pad Length	Y2			2.60
Contact Pad Spacing	C1		3.90	
Contact Pad Spacing	C2		3.90	
Contact Pad Width (X24)	X1			0.30
Contact Pad Length (X24)	Y1			0.85
Contact Pad to Center Pad (X24)	G1	0.23		
Contact Pad to Contact Pad (X20)	G2	0.20		
Thermal Via Diameter	V		0.30	
Thermal Via Pitch	EV		1.00	

**Notes:**

- Dimensioning and tolerancing per ASME Y14.5M  
BSC: Basic Dimension. Theoretically exact value shown without tolerances.
- For best soldering results, thermal vias, if used, should be filled or tented to avoid solder loss during reflow process

**Package Outlines and Dimensions**

**24-Lead Very Thin Plastic Quad Flat, No Lead Package (MJ) – 4x4x0.9 mm Body [VQFN]  
SMSC Legacy S4QFN**

**Note:** For the most current package drawings, please see the Microchip Packaging Specification located at <http://www.microchip.com/packaging>

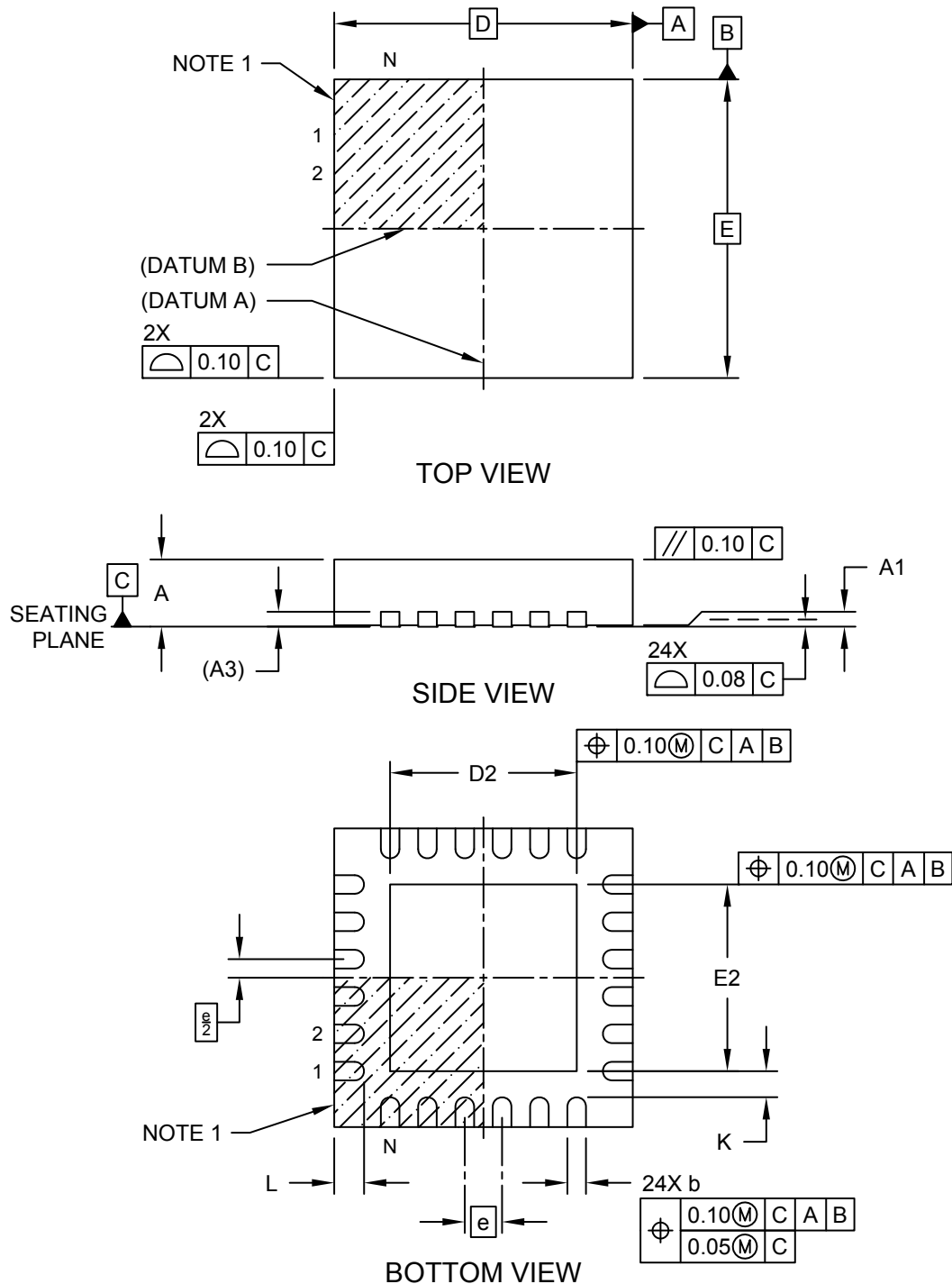

**Package Outlines and Dimensions**

**24-Lead Very Thin Plastic Quad Flat, No Lead Package (MJ) – 4x4x0.9 mm Body [VQFN]  
SMSC Legacy S4QFN**

**Note:** For the most current package drawings, please see the Microchip Packaging Specification located at <http://www.microchip.com/packaging>

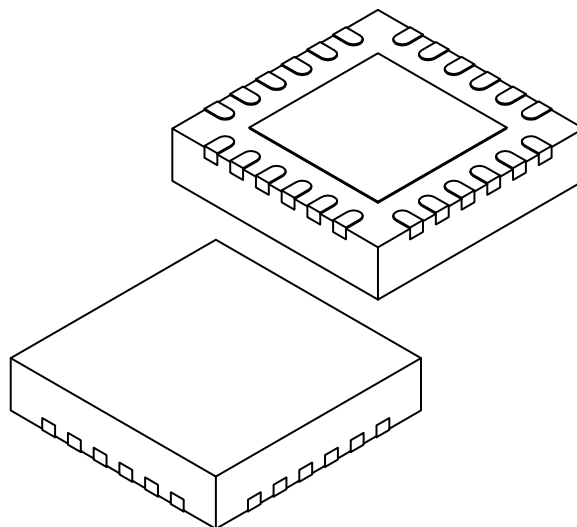

Dimension Limits	Units	MILLIMETERS		
		MIN	NOM	MAX
Number of Terminals	N	24		
Pitch	e	0.50 BSC		
Overall Height	A	0.80	0.90	1.00
Standoff	A1	0.00	0.02	0.05
Terminal Thickness	A3	0.20 REF		
Overall Width	E	4.00 BSC		
Exposed Pad Width	E2	2.40	2.50	2.60
Overall Length	D	4.00 BSC		
Exposed Pad Length	D2	2.40	2.50	2.60
Terminal Width	b	0.18	0.25	0.30
Terminal Length	L	0.35	0.40	0.45
Terminal-to-Exposed Pad	K	0.25	-	-

**Notes:**

- Pin 1 visual index feature may vary, but must be located within the hatched area.
- Package is saw singulated
- Dimensioning and tolerancing per ASME Y14.5M
  - BSC: Basic Dimension. Theoretically exact value shown without tolerances.
  - REF: Reference Dimension, usually without tolerance, for information purposes only.

---



---

## Footprint Outlines and Dimensions

---



---

### 24-Lead Very Thin Plastic Quad Flat, No Lead Package (MJ) – 4x4x0.9 mm Body [VQFN] SMSC Legacy S4QFN

**Note:** For the most current package drawings, please see the Microchip Packaging Specification located at <http://www.microchip.com/packaging>

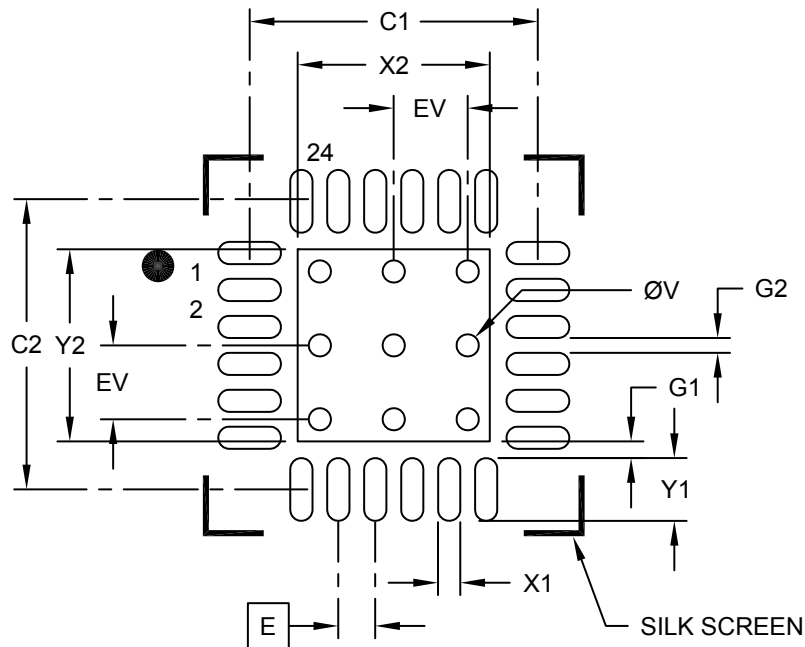

### RECOMMENDED LAND PATTERN

Dimension Limits	Units	MILLIMETERS		
		MIN	NOM	MAX
Contact Pitch	E	0.50 BSC		
Optional Center Pad Width	X2			2.60
Optional Center Pad Length	Y2			2.60
Contact Pad Spacing	C1		3.90	
Contact Pad Spacing	C2		3.90	
Contact Pad Width (X24)	X1			0.30
Contact Pad Length (X24)	Y1			0.85
Contact Pad to Center Pad (X24)	G1	0.23		
Contact Pad to Contact Pad (X20)	G2	0.20		
Thermal Via Diameter	V		0.30	
Thermal Via Pitch	EV		1.00	

**Notes:**

1. Dimensioning and tolerancing per ASME Y14.5M  
BSC: Basic Dimension. Theoretically exact value shown without tolerances.
2. For best soldering results, thermal vias, if used, should be filled or tented to avoid solder loss during reflow process

**Package Outlines and Dimensions**

**24-Lead Plastic Quad Flat, No Lead Package (LY) – 5x5x1.0 mm Body [QFN or VQFN]**

**Note:** For the most current package drawings, please see the Microchip Packaging Specification located at <http://www.microchip.com/packaging>

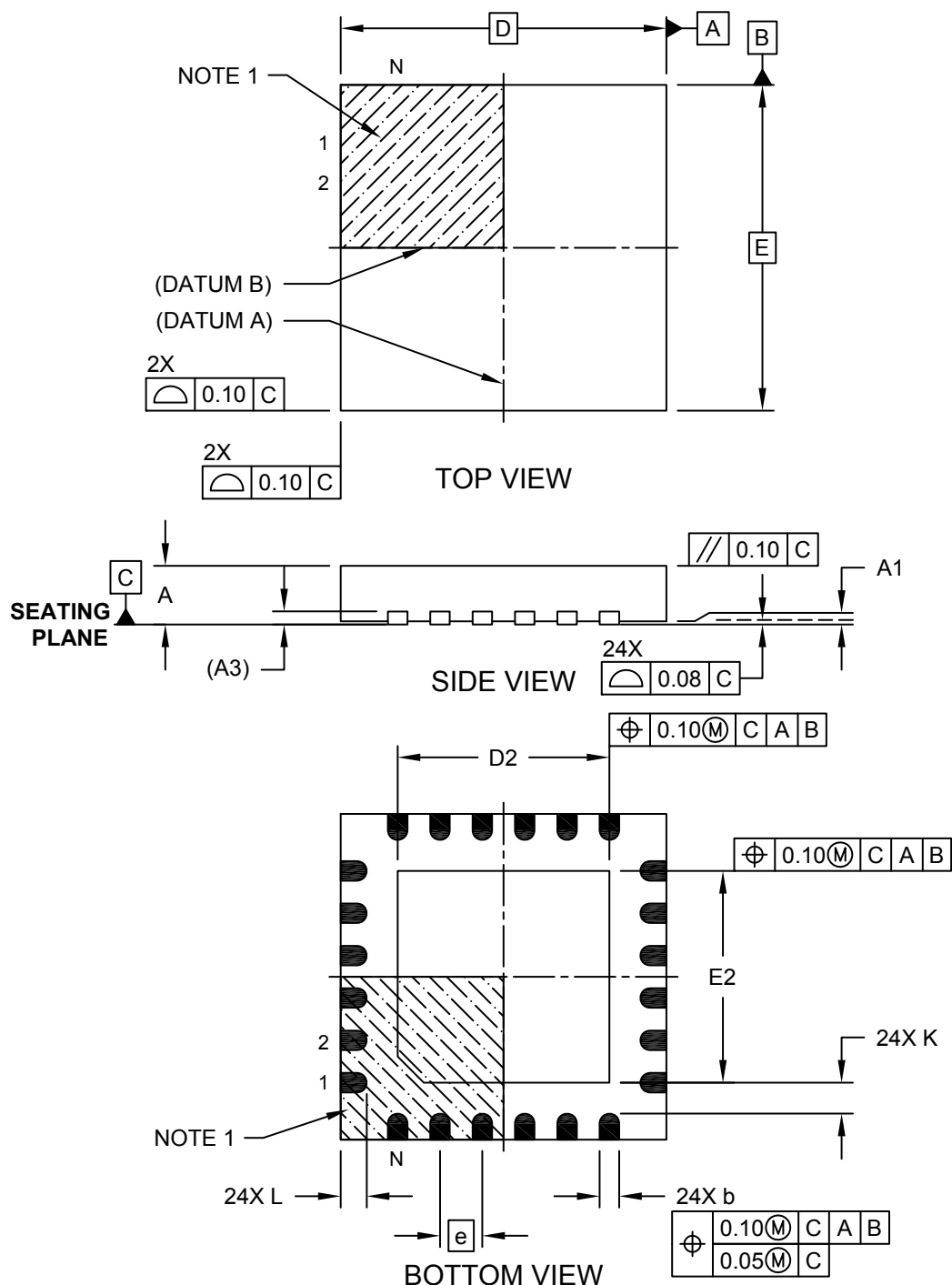



---



---

## Package Outlines and Dimensions

---



---

### 24-Lead Plastic Quad Flat, No Lead Package (LY) – 5x5x1.0 mm Body [QFN or VQFN]

**Note:** For the most current package drawings, please see the Microchip Packaging Specification located at <http://www.microchip.com/packaging>

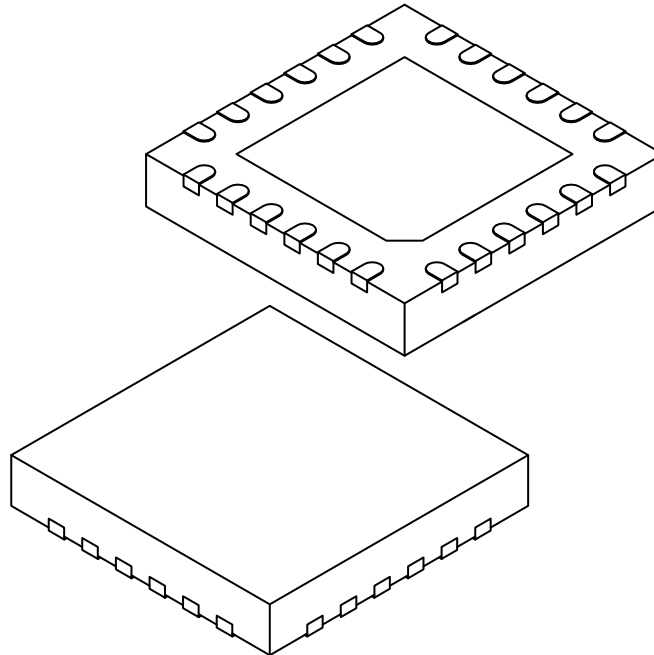

Dimension Limits	Units	MILLIMETERS		
		MIN	NOM	MAX
Number of Terminals	N	24		
Pitch	e	0.65 BSC		
Overall Height	A	0.80	0.90	1.00
Standoff	A1	0.00	0.02	0.05
Terminal Thickness	(A3)	0.20 REF		
Overall Width	E	5.00 BSC		
Exposed Pad Width	E2	3.20	3.25	3.30
Overall Length	D	5.00 BSC		
Exposed Pad Length	D2	3.20	3.25	3.30
Terminal Width	b	0.25	0.30	0.35
Terminal Length	L	0.35	0.40	0.45
Terminal-to-Exposed Pad	K	0.20	-	-

**Notes:**

1. Pin 1 visual index feature may vary, but must be located within the hatched area.
2. Package is saw singulated.
3. Dimensioning and tolerancing per ASME Y14.5M.
  - BSC: Basic Dimension. Theoretically exact value shown without tolerances.
  - REF: Reference Dimension, usually without tolerance, for information purposes only.

**Footprint Outlines and Dimensions**

**24-Lead Plastic Quad Flat, No Lead Package (LY) – 5x5x1.0 mm Body [QFN or VQFN]**

**Note:** For the most current package drawings, please see the Microchip Packaging Specification located at <http://www.microchip.com/packaging>

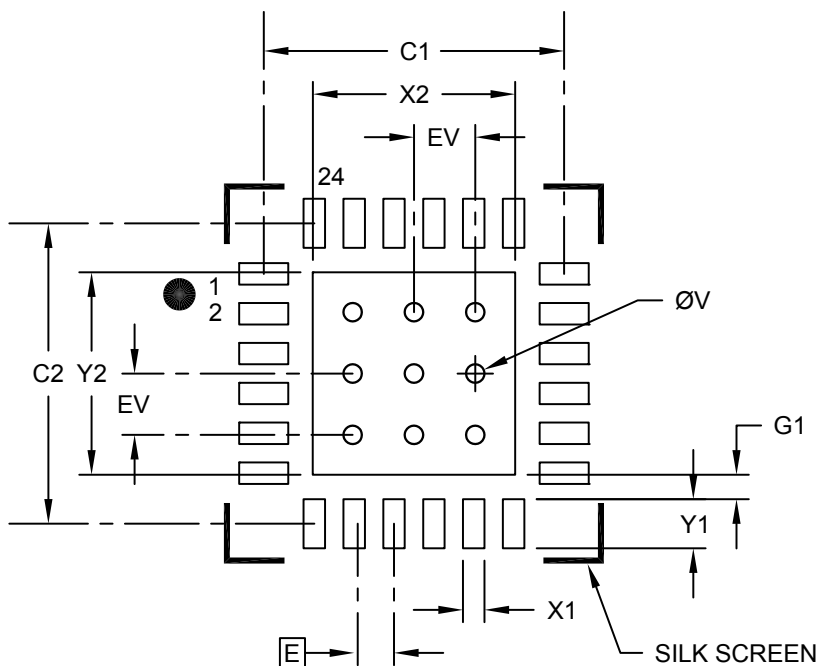

**RECOMMENDED LAND PATTERN**

Dimension Limits	Units	MILLIMETERS		
		MIN	NOM	MAX
Contact Pitch	E	0.65 BSC		
Center Pad Width	X2			3.30
Center Pad Length	Y2			3.30
Contact Pad Spacing	C1		4.90	
Contact Pad Spacing	C2		4.90	
Contact Pad Width (X24)	X1			0.35
Contact Pad Length (X24)	Y1			0.80
Contact Pad to Center Pad (X24)	G1	0.20		
Thermal Via Diameter	V		0.30	
Thermal Via Pitch	EV		1.00	

Notes:

1. Dimensioning and tolerancing per ASME Y14.5M

BSC: Basic Dimension. Theoretically exact value shown without tolerances.

Microchip Technology Drawing C04-2364A

**Package Outlines and Dimensions**

**28-Lead Very Thin Plastic Quad Flat Pack, No Lead Package (PV) 5x5 mm Body [VQFN] With Rectangular Exposed Pad**

**Note:** For the most current package drawings, please see the Microchip Packaging Specification located at <http://www.microchip.com/packaging>

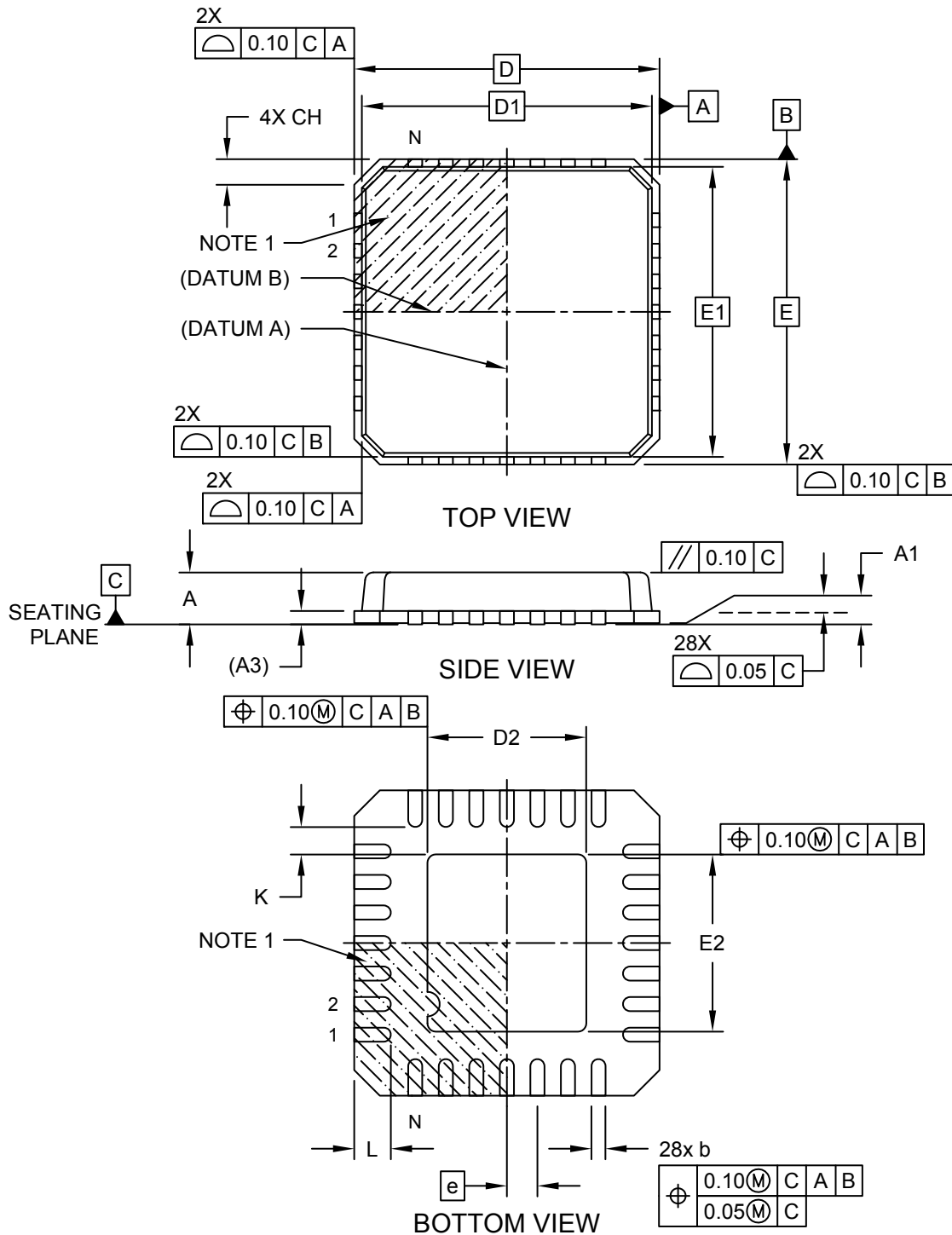

Microchip Technology Drawing C04-334A Sheet 1 of 2

**Package Outlines and Dimensions**

**28-Lead Very Thin Plastic Quad Flat Pack, No Lead Package (PV) 5x5 mm Body [VQFN]  
With Rectangular Exposed Pad**

**Note:** For the most current package drawings, please see the Microchip Packaging Specification located at <http://www.microchip.com/packaging>

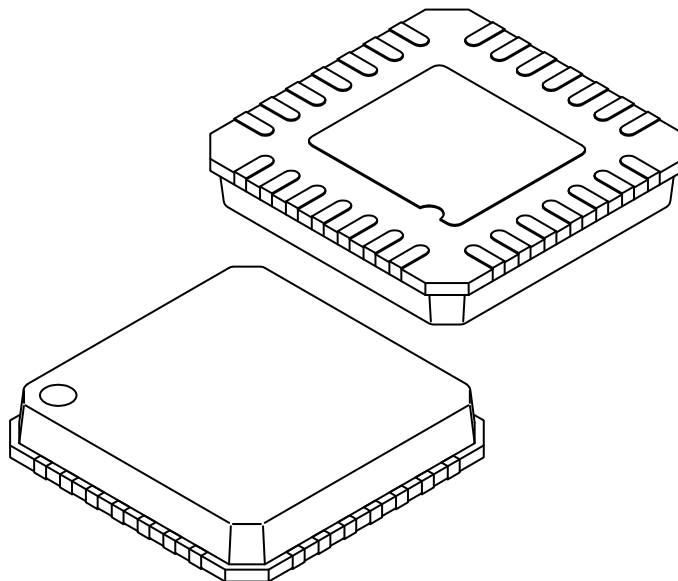

Dimension Limits	Units	MILLIMETERS		
		MIN	NOM	MAX
Number of Terminals	N	28		
Pitch	e	0.50 BSC		
Overall Height	A	0.80	0.85	0.90
Standoff	A1	0.00	0.01	0.05
Terminal Thickness	(A3)	0.20 REF		
Overall Width	D	5.00 BSC		
Molded Cap Width	D1	4.75 BSC		
Exposed Pad Width	D2	2.50	2.60	2.70
Overall Length	E	5.00 BSC		
Molded Cap Length	E1	4.75 BSC		
Exposed Pad Length	E2	2.80	2.90	3.00
Corner Chamfer	CH	0.24	0.42	0.60
Terminal Width	b	0.18	0.23	0.30
Terminal Length	L	0.50	0.60	0.70
Terminal-to-Exposed-Pad	K	0.20	-	-

**Notes:**

1. Pin 1 visual index feature may vary, but must be located within the hatched area.
2. Package is punch singulated
3. Dimensioning and tolerancing per ASME Y14.5M

BSC: Basic Dimension. Theoretically exact value shown without tolerances.

REF: Reference Dimension, usually without tolerance, for information purposes only.

---



---

## Footprint Outlines and Dimensions

---



---

### 28-Lead Very Thin Plastic Quad Flat, No Lead Package (PV) - 5x5 mm Body [VQFN] With Rectangular Exposed Pad

**Note:** For the most current package drawings, please see the Microchip Packaging Specification located at <http://www.microchip.com/packaging>

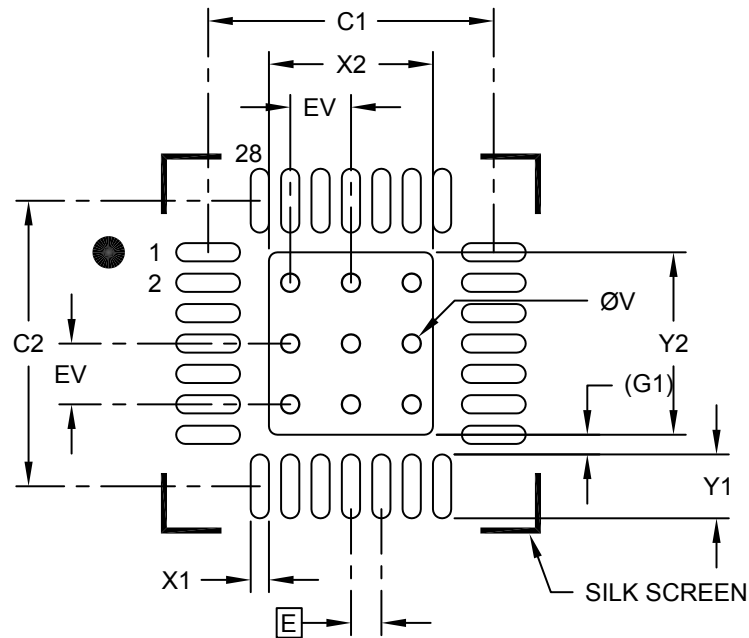

### RECOMMENDED LAND PATTERN

	Units	MILLIMETERS		
		MIN	NOM	MAX
	Dimension Limits			
Contact Pitch	E	0.50 BSC		
Optional Center Pad Width	X2			2.70
Optional Center Pad Length	Y2			3.00
Contact Pad Spacing	C1		4.70	
Contact Pad Spacing	C2		4.70	
Contact Pad Width (X28)	X1			0.30
Contact Pad Length (X28)	Y1			1.05
Contact Pad to Center Pad (X28)	(G1)	0.475 REF		
Thermal Via Diameter	V		0.30	
Thermal Via Pitch	EV		1.00	

**Notes:**

1. Dimensioning and tolerancing per ASME Y14.5M

BSC: Basic Dimension. Theoretically exact value shown without tolerances.

Microchip Technology Drawing C04-2334A

## Package Outlines and Dimensions

### 28-Lead Plastic Quad Flat, No Lead Package (MQ) – 5x5x0.9 mm Body [QFN or VQFN]

**Note:** For the most current package drawings, please see the Microchip Packaging Specification located at <http://www.microchip.com/packaging>

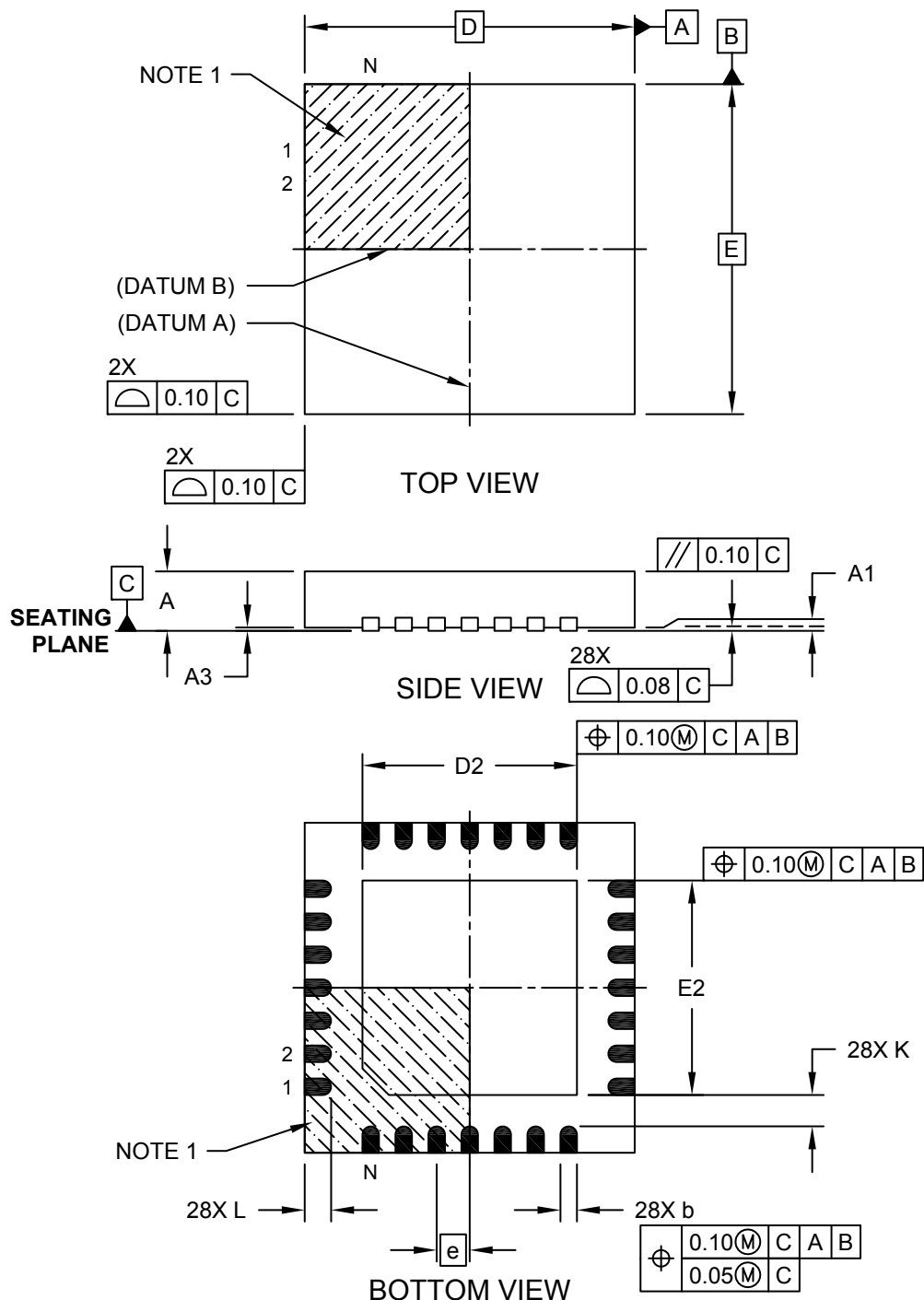

---



---

## Package Outlines and Dimensions

---



---

### 28-Lead Plastic Quad Flat, No Lead Package (MQ) – 5x5x0.9 mm Body [QFN or VQFN]

**Note:** For the most current package drawings, please see the Microchip Packaging Specification located at <http://www.microchip.com/packaging>

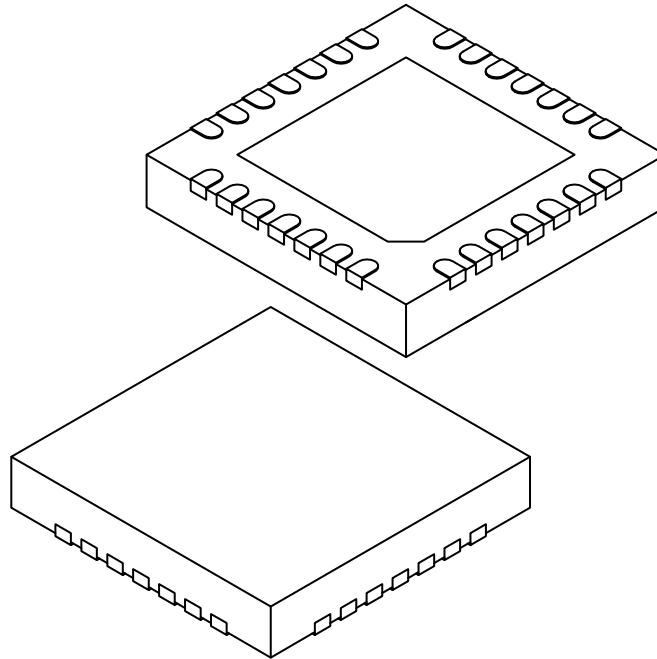

Dimension Limits	Units	MILLIMETERS		
		MIN	NOM	MAX
Number of Pins	N	28		
Pitch	e	0.50 BSC		
Overall Height	A	0.80	0.90	1.00
Standoff	A1	0.00	0.02	0.05
Contact Thickness	A3	0.20 REF		
Overall Width	E	5.00 BSC		
Exposed Pad Width	E2	3.15	3.25	3.35
Overall Length	D	5.00 BSC		
Exposed Pad Length	D2	3.15	3.25	3.35
Contact Width	b	0.18	0.25	0.30
Contact Length	L	0.35	0.40	0.45
Contact-to-Exposed Pad	K	0.20	-	-

**Notes:**

1. Pin 1 visual index feature may vary, but must be located within the hatched area.
2. Package is saw singulated.
3. Dimensioning and tolerancing per ASME Y14.5M.
  - BSC: Basic Dimension. Theoretically exact value shown without tolerances.
  - REF: Reference Dimension, usually without tolerance, for information purposes only.

**Footprint Outlines and Dimensions**

**28-Lead Plastic Quad Flat, No Lead Package (MQ) – 5x5x0.9 mm Body  
[QFN or VQFN]**

**Note:** For the most current package drawings, please see the Microchip Packaging Specification located at <http://www.microchip.com/packaging>

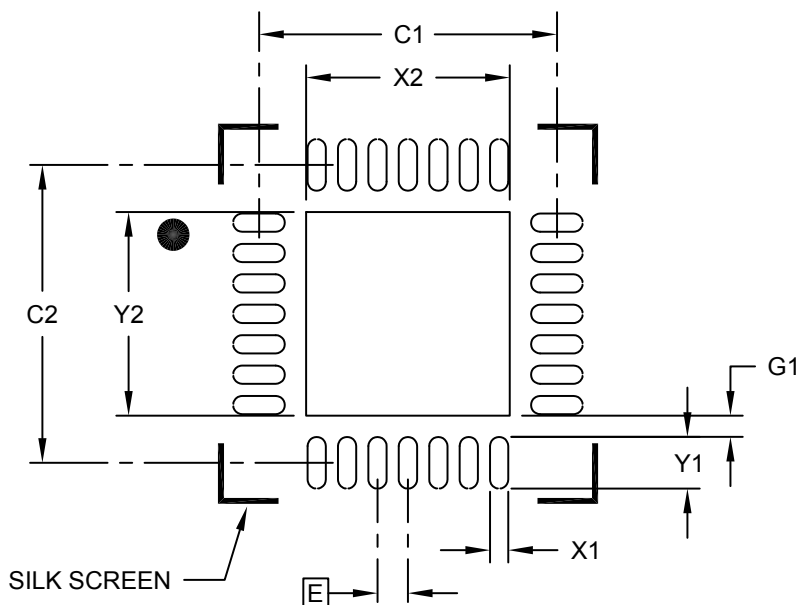

**RECOMMENDED LAND PATTERN**

Dimension Limits	Units	MILLIMETERS		
		MIN	NOM	MAX
Contact Pitch	E	0.50 BSC		
Optional Center Pad Width	W2			3.35
Optional Center Pad Length	T2			3.35
Contact Pad Spacing	C1		4.90	
Contact Pad Spacing	C2		4.90	
Contact Pad Width (X28)	X1			0.30
Contact Pad Length (X28)	Y1			0.85
Contact Pad Length (X28)	G1	0.35		

**Notes:**

1. Dimensioning and tolerancing per ASME Y14.5M

BSC: Basic Dimension. Theoretically exact value shown without tolerances.

Microchip Technology Drawing No. C04-2140A



**Package Outlines and Dimensions**

**28-Lead Plastic Quad Flat, No Lead Package (MQY) – 5x5x0.9 mm Body [QFN or VQFN]**

**Note:** For the most current package drawings, please see the Microchip Packaging Specification located at <http://www.microchip.com/packaging>

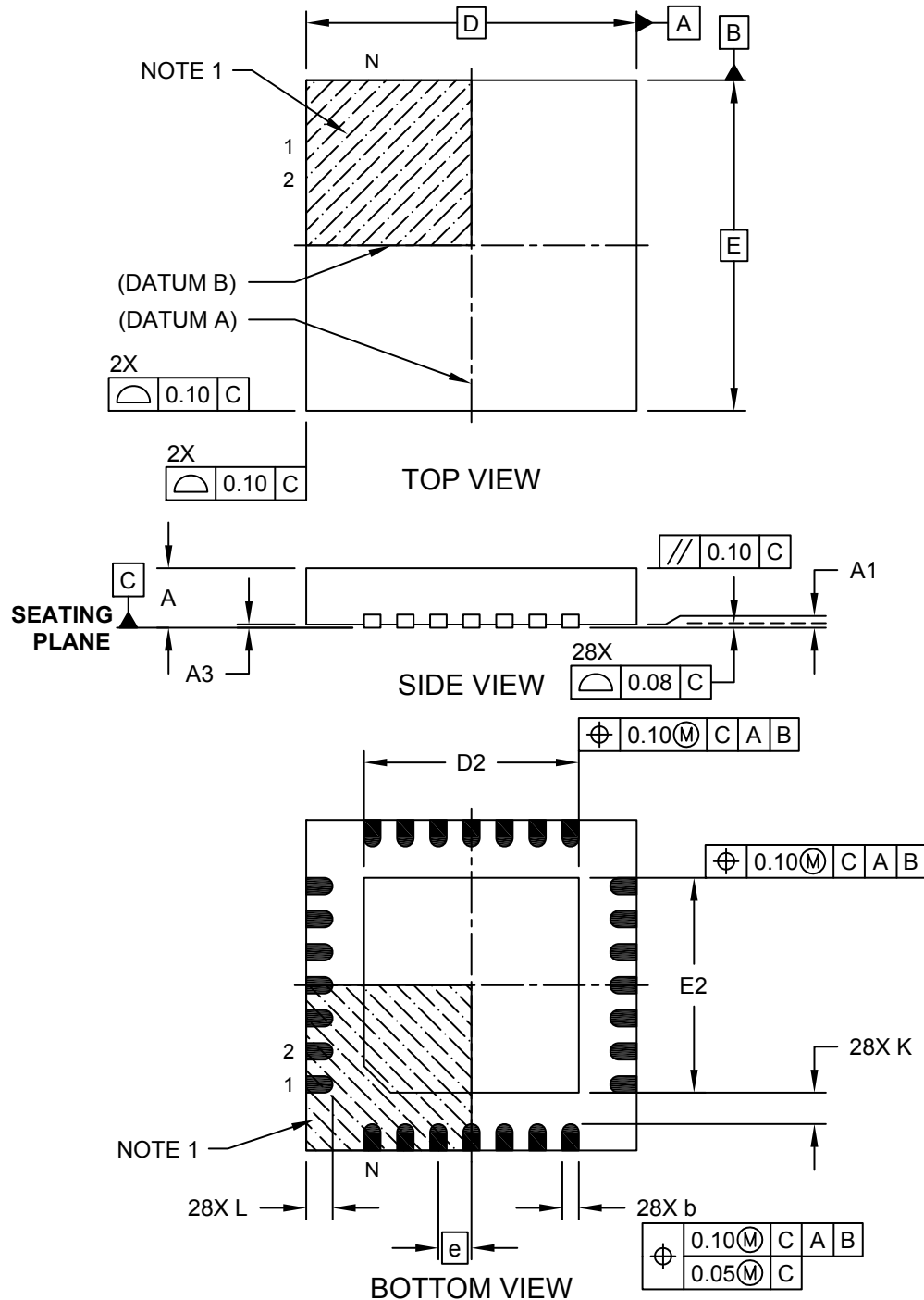

**Package Outlines and Dimensions**

**28-Lead Plastic Quad Flat, No Lead Package (MQY) – 5x5x0.9 mm Body [QFN or VQFN]**

**Note:** For the most current package drawings, please see the Microchip Packaging Specification located at <http://www.microchip.com/packaging>

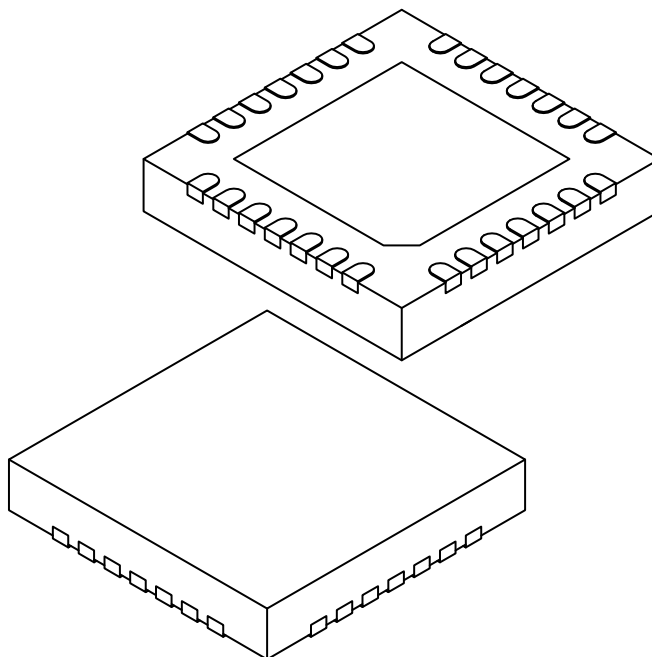

Dimension Limits	Units	MILLIMETERS		
		MIN	NOM	MAX
Number of Pins	N	28		
Pitch	e	0.50 BSC		
Overall Height	A	0.80	0.90	1.00
Standoff	A1	0.00	0.02	0.05
Contact Thickness	A3	0.20 REF		
Overall Width	E	5.00 BSC		
Exposed Pad Width	E2	3.15	3.25	3.35
Overall Length	D	5.00 BSC		
Exposed Pad Length	D2	3.15	3.25	3.35
Contact Width	b	0.18	0.25	0.30
Contact Length	L	0.35	0.40	0.45
Contact-to-Exposed Pad	K	0.20	-	-

**Notes:**

- Pin 1 visual index feature may vary, but must be located within the hatched area.
- Package is saw singulated.
- Dimensioning and tolerancing per ASME Y14.5M.
  - BSC: Basic Dimension. Theoretically exact value shown without tolerances.
  - REF: Reference Dimension, usually without tolerance, for information purposes only.

---



---

## Footprint Outlines and Dimensions

---



---

### 28-Lead Plastic Quad Flat, No Lead Package (MQY) – 5x5x0.9 mm Body [QFN or VQFN]

**Note:** For the most current package drawings, please see the Microchip Packaging Specification located at <http://www.microchip.com/packaging>

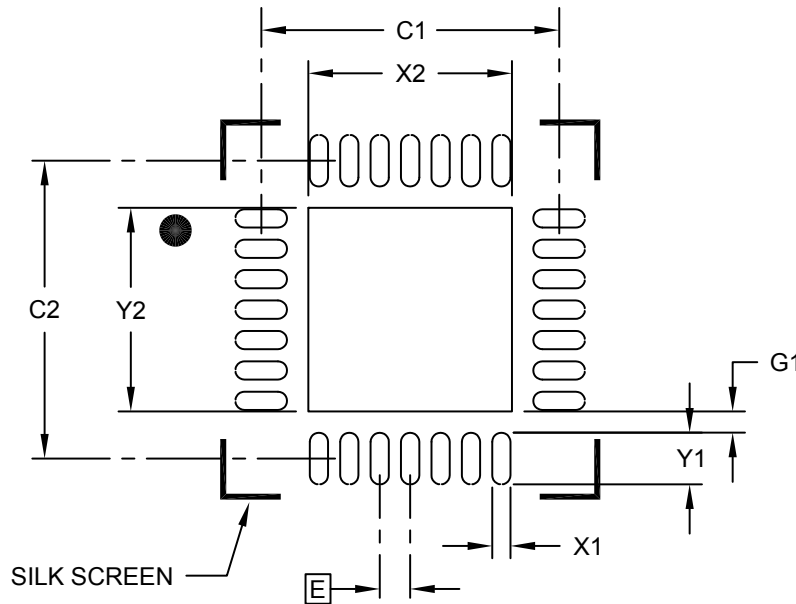

**RECOMMENDED LAND PATTERN**

Dimension Limits	Units	MILLIMETERS		
		MIN	NOM	MAX
Contact Pitch	E	0.50 BSC		
Optional Center Pad Width	W2			3.35
Optional Center Pad Length	T2			3.35
Contact Pad Spacing	C1		4.90	
Contact Pad Spacing	C2		4.90	
Contact Pad Width (X28)	X1			0.30
Contact Pad Length (X28)	Y1			0.85
Contact Pad Length (X28)	G1	0.35		

**Notes:**

1. Dimensioning and tolerancing per ASME Y14.5M

BSC: Basic Dimension. Theoretically exact value shown without tolerances.

Microchip Technology Drawing No. C04-2140A

**Package Outlines and Dimensions**

**28-Lead Very Thin Plastic Quad Flat, No Lead Package (5N) - 6x6x1.0 mm Body [VQFN]  
4.10x4.10 mm Exposed Pad, Wettable Flanks (Stepped)**

**Note:** For the most current package drawings, please see the Microchip Packaging Specification located at <http://www.microchip.com/packaging>

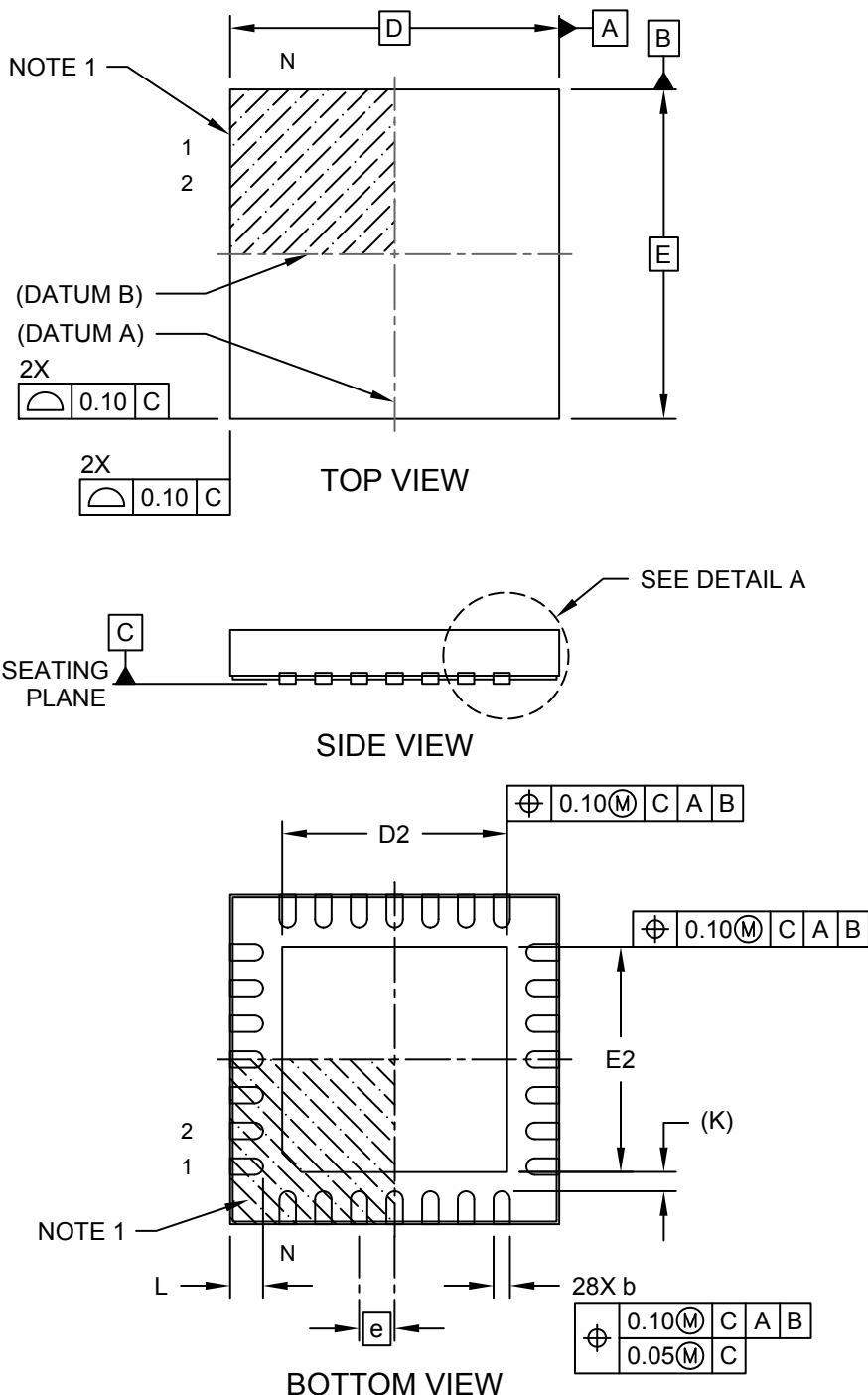

---



---

## Package Outlines and Dimensions

---



---

### 28-Lead Very Thin Plastic Quad Flat, No Lead Package (5N) - 6x6x1.0 mm Body [VQFN] 4.10x4.10 mm Exposed Pad, Wettable Flanks (Stepped)

**Note:** For the most current package drawings, please see the Microchip Packaging Specification located at <http://www.microchip.com/packaging>

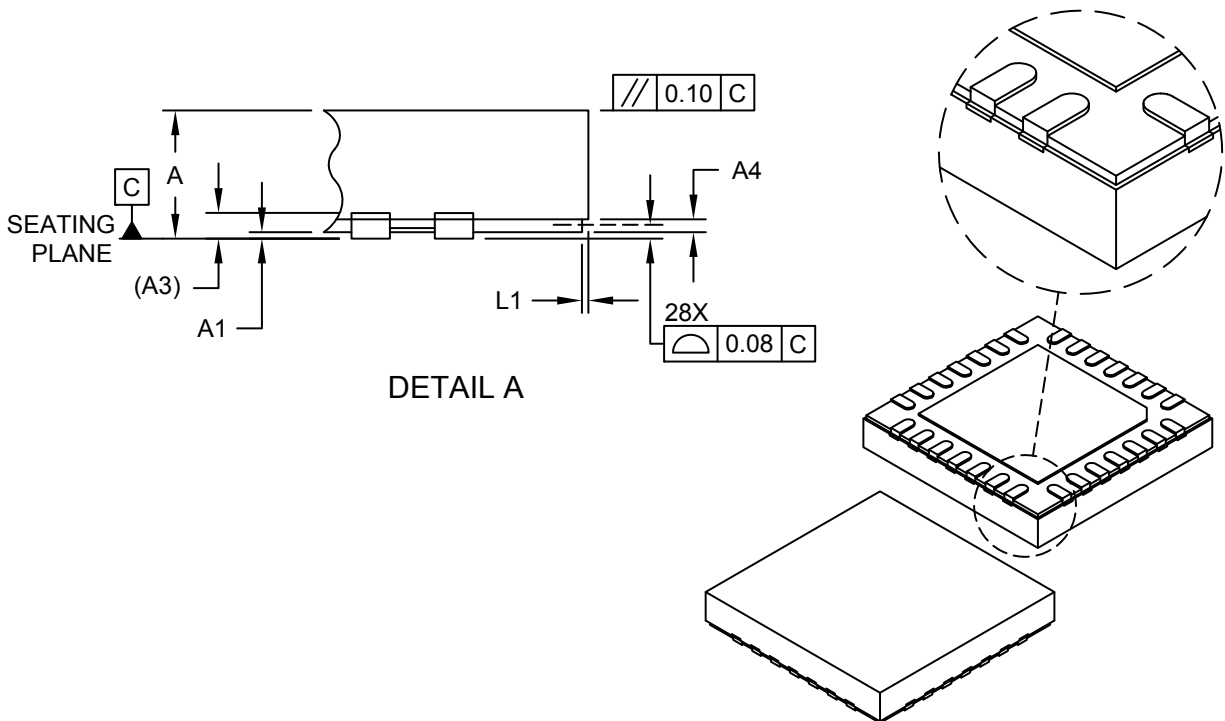

Dimension Limits	Units	MILLIMETERS		
		MIN	NOM	MAX
Number of Terminals	N	28		
Pitch	e	0.65 BSC		
Overall Height	A	0.80	0.90	1.00
Standoff	A1	0.00	0.02	0.05
Terminal Thickness	A3	0.20 REF		
Step Height	A4	0.05	0.12	0.19
Overall Width	E	6.00 BSC		
Exposed Pad Width	E2	4.00	4.10	4.20
Overall Length	D	6.00 BSC		
Exposed Pad Length	D2	4.00	4.10	4.20
Terminal Width	b	0.25	0.30	0.35
Terminal Length	L	0.50	0.60	0.70
Step Length	L1	0.035	0.060	0.085
Terminal-to-Exposed Pad	K	0.35 REF		

**Notes:**

1. Pin 1 visual index feature may vary, but must be located within the hatched area.
2. Package is saw singulated
3. Dimensioning and tolerancing per ASME Y14.5M

BSC: Basic Dimension. Theoretically exact value shown without tolerances.

REF: Reference Dimension, usually without tolerance, for information purposes only.

**Footprint Outlines and Dimensions**

**28-Lead Very Thin Plastic Quad Flat, No Lead Package (5N) - 6x6x1.0 mm Body [VQFN]  
4.10x4.10 mm Exposed Pad, Wettable Flanks (Stepped)**

**Note:** For the most current package drawings, please see the Microchip Packaging Specification located at <http://www.microchip.com/packaging>

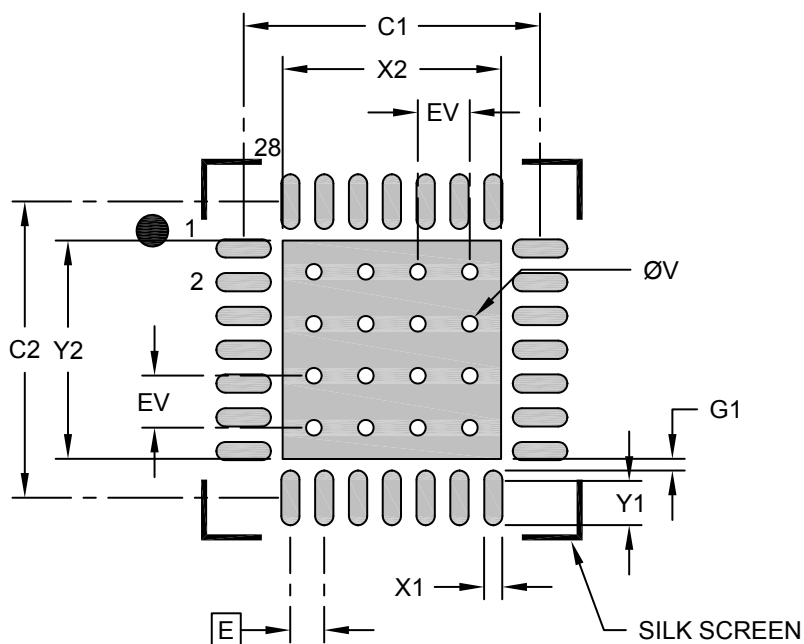

**RECOMMENDED LAND PATTERN**

Dimension Limits	Units	MILLIMETERS		
		MIN	NOM	MAX
Contact Pitch	E	0.65 BSC		
Optional Center Pad Width	X2			3.80
Optional Center Pad Length	Y2			3.80
Contact Pad Spacing	C1		5.90	
Contact Pad Spacing	C2		5.90	
Contact Pad Width (X28)	X1			0.35
Contact Pad Length (X28)	Y1			0.85
Contact Pad to Center Pad (X28)	G1	0.20		
Thermal Via Diameter	V		0.30	
Thermal Via Pitch	EV		1.00	

**Notes:**

1. Dimensioning and tolerancing per ASME Y14.5M  
BSC: Basic Dimension. Theoretically exact value shown without tolerances.
2. For best soldering results, thermal vias, if used, should be filled or tented to avoid solder loss during reflow process

**Package Outlines and Dimensions**

**28-Lead Very Thin Plastic Quad Flat, No Lead Package (4N) - 6x6x1.0 mm Body [VQFN]  
3.70x3.70 mm Exposed Pad, Wettable Flanks (Stepped)**

**Note:** For the most current package drawings, please see the Microchip Packaging Specification located at <http://www.microchip.com/packaging>

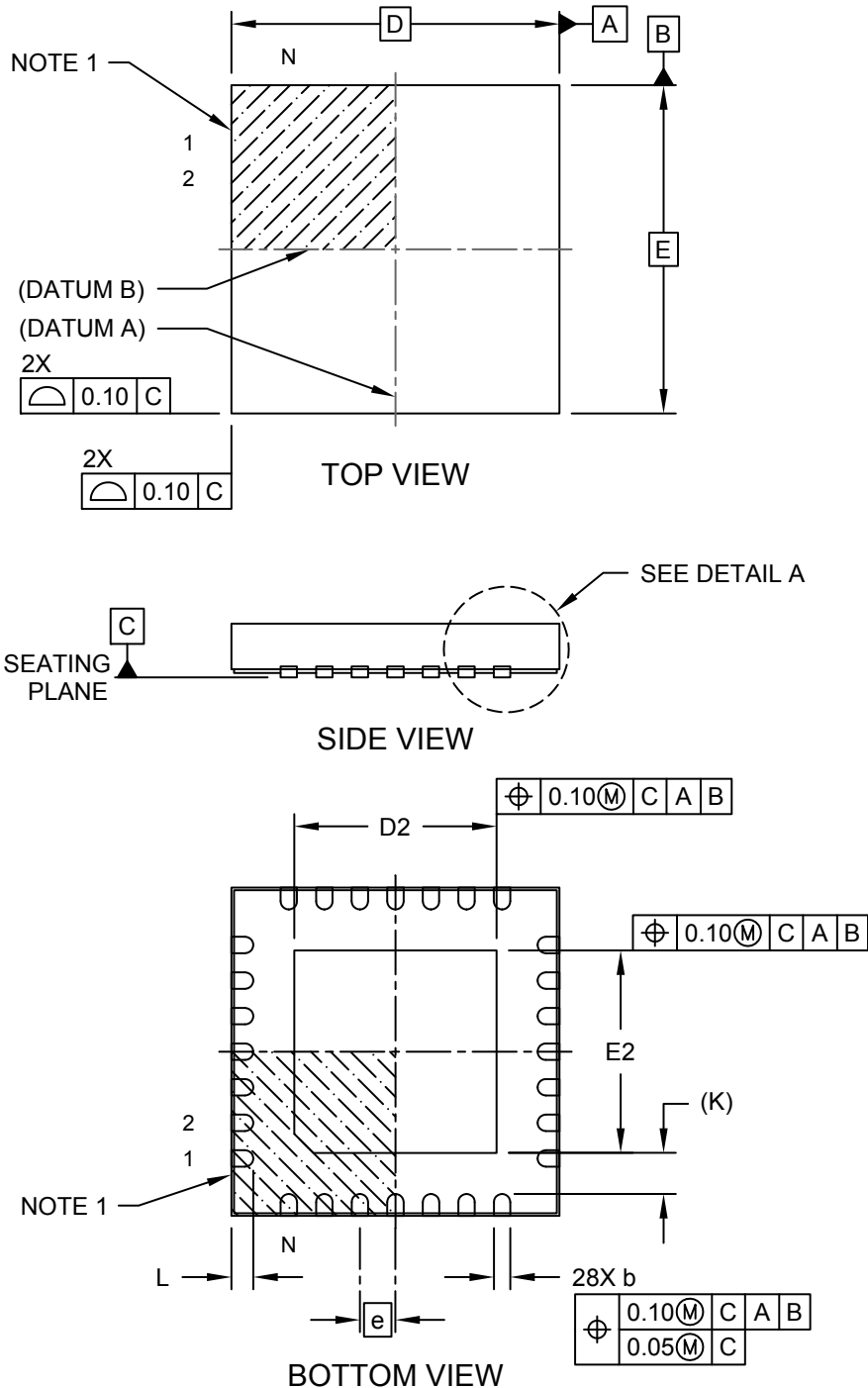

## Package Outlines and Dimensions

### 28-Lead Very Thin Plastic Quad Flat, No Lead Package (4N) - 6x6x1.0 mm Body [VQFN] 3.70x3.70 mm Exposed Pad, Wettable Flanks (Stepped)

**Note:** For the most current package drawings, please see the Microchip Packaging Specification located at <http://www.microchip.com/packaging>

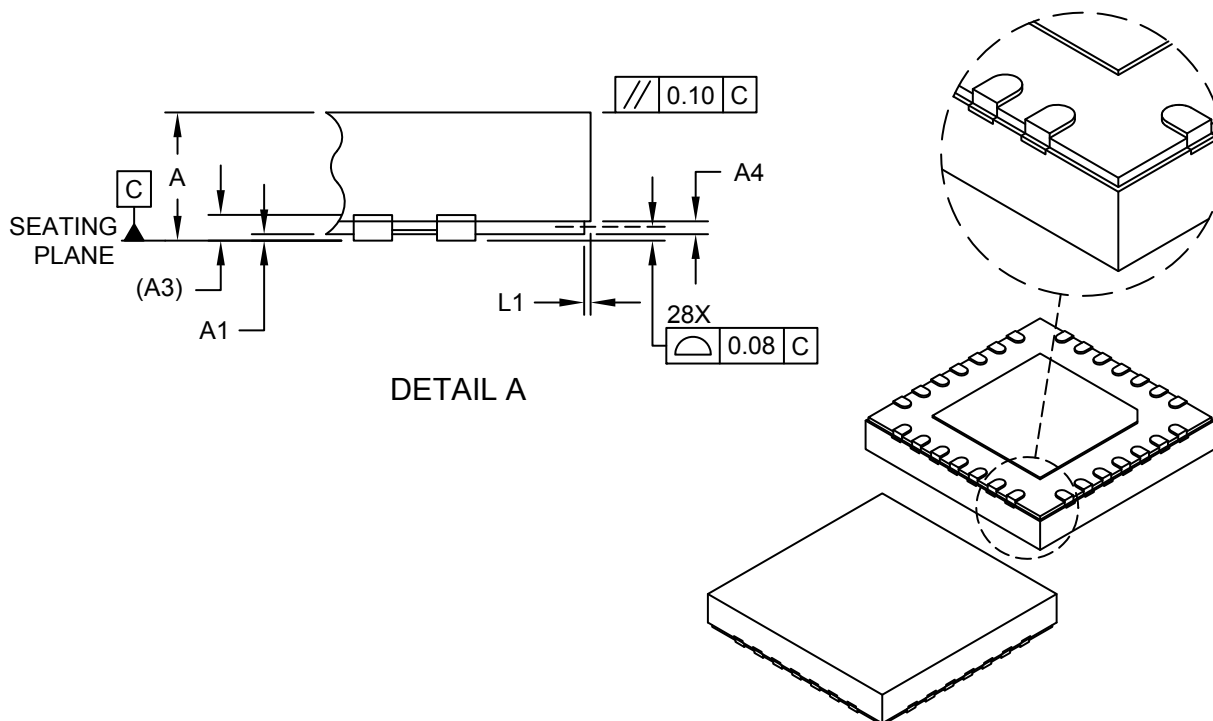

Dimension Limits	Units	MILLIMETERS		
		MIN	NOM	MAX
Number of Terminals	N	28		
Pitch	e	0.65 BSC		
Overall Height	A	0.80	0.90	1.00
Standoff	A1	0.00	0.02	0.05
Terminal Thickness	A3	0.20 REF		
Step Height	A4	0.05	0.12	0.19
Overall Width	E	6.00 BSC		
Exposed Pad Width	E2	3.60	3.70	3.80
Overall Length	D	6.00 BSC		
Exposed Pad Length	D2	3.60	3.70	3.80
Terminal Width	b	0.23	0.30	0.35
Terminal Length	L	0.30	0.40	0.50
Step Length	L1	0.035	0.060	0.085
Terminal-to-Exposed Pad	K	0.75 REF		

**Notes:**

1. Pin 1 visual index feature may vary, but must be located within the hatched area.
2. Package is saw singulated
3. Dimensioning and tolerancing per ASME Y14.5M

BSC: Basic Dimension. Theoretically exact value shown without tolerances.

REF: Reference Dimension, usually without tolerance, for information purposes only.



---



---

## Footprint Outlines and Dimensions

---



---

### 28-Lead Very Thin Plastic Quad Flat, No Lead Package (4N) - 6x6x1.0 mm Body [VQFN] 3.70x3.70 mm Exposed Pad, Wettable Flanks (Stepped)

**Note:** For the most current package drawings, please see the Microchip Packaging Specification located at <http://www.microchip.com/packaging>

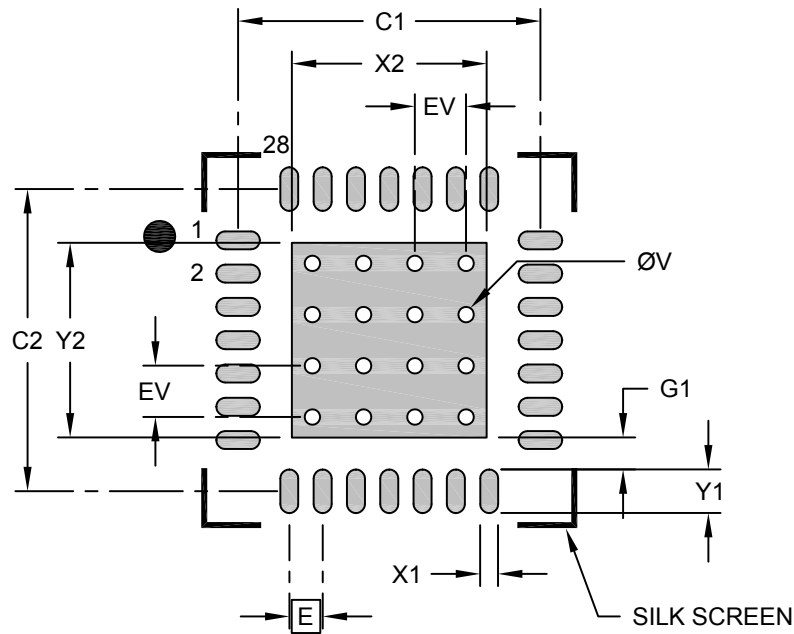

### RECOMMENDED LAND PATTERN

		Units	MILLIMETERS		
Dimension Limits			MIN	NOM	MAX
Contact Pitch	E		0.65 BSC		
Optional Center Pad Width	X2				3.80
Optional Center Pad Length	Y2				3.80
Contact Pad Spacing	C1			5.90	
Contact Pad Spacing	C2			5.90	
Contact Pad Width (X28)	X1				0.35
Contact Pad Length (X28)	Y1				0.85
Contact Pad to Center Pad (X28)	G1	0.20			
Thermal Via Diameter	V			0.30	
Thermal Via Pitch	EV			1.00	

**Notes:**

1. Dimensioning and tolerancing per ASME Y14.5M  
BSC: Basic Dimension. Theoretically exact value shown without tolerances.
2. For best soldering results, thermal vias, if used, should be filled or tented to avoid solder loss during reflow process

**Package Outlines and Dimensions**

**28-Lead Very Thin Plastic Quad Flat, No Lead Package (9PX) - 5x5 mm Body [VQFN]  
With Stepped Wettable Flanks, 3.25x3.25mm Exposed Pad**

**Note:** For the most current package drawings, please see the Microchip Packaging Specification located at <http://www.microchip.com/packaging>

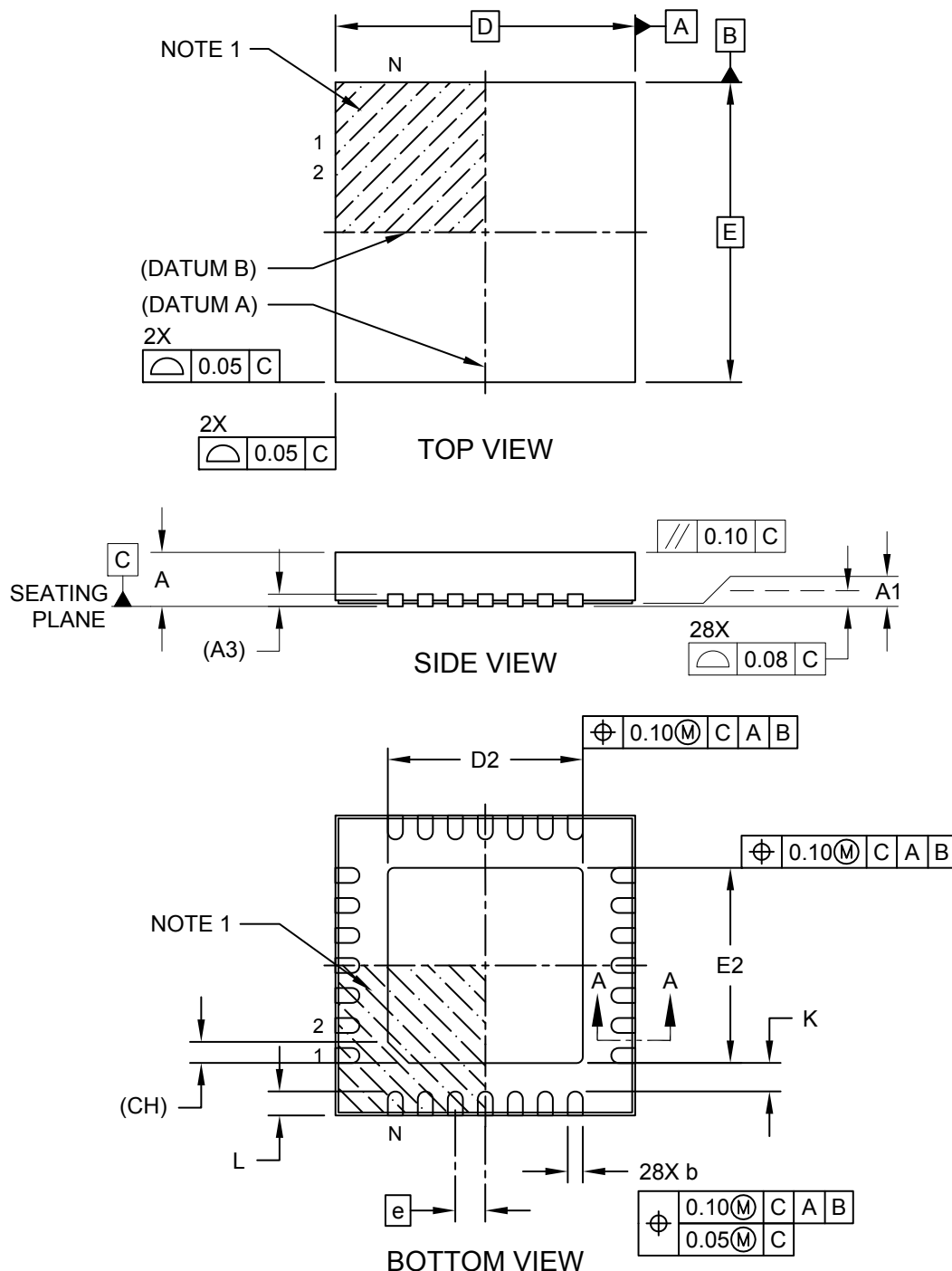

---



---

## Package Outlines and Dimensions

---



---

### 28-Lead Very Thin Plastic Quad Flat, No Lead Package (9PX) - 5x5 mm Body [VQFN] With Stepped Wettable Flanks, 3.25x3.25mm Exposed Pad

**Note:** For the most current package drawings, please see the Microchip Packaging Specification located at <http://www.microchip.com/packaging>

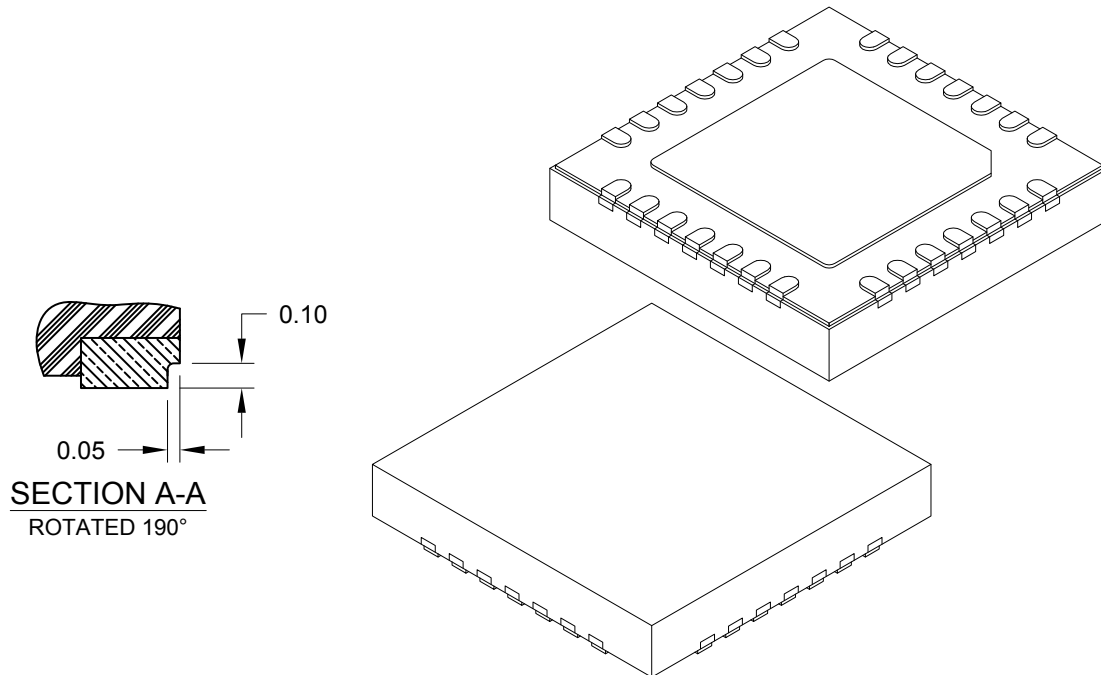

Dimension Limits	Units	MILLIMETERS		
		MIN	NOM	MAX
Number of Terminals	N	28		
Pitch	e	0.50 BSC		
Overall Height	A	0.80	0.85	0.90
Standoff	A1	0.00	0.02	0.05
Terminal Thickness	A3	0.203 REF		
Overall Length	D	5.00 BSC		
Exposed Pad Length	D2	3.15	3.25	3.35
Overall Width	E	5.00 BSC		
Exposed Pad Width	E2	3.15	3.25	3.35
Terminal Width	b	0.20	0.25	0.30
Terminal Length	L	0.35	0.40	0.45
Terminal-to-Exposed-Pad	K	0.20	-	-
Exposed Pad Chamfer	CH	0.35 REF		

**Notes:**

1. Pin 1 visual index feature may vary, but must be located within the hatched area.
2. Package is saw singulated
3. Dimensioning and tolerancing per ASME Y14.5M

BSC: Basic Dimension. Theoretically exact value shown without tolerances.

REF: Reference Dimension, usually without tolerance, for information purposes only.

**Footprint Outlines and Dimensions**

**28-Lead Very Thin Plastic Quad Flat, No Lead Package (9PX) - 5x5 mm Body [VQFN]  
With Stepped Wettable Flanks, 3.25x3.25mm Exposed Pad**

**Note:** For the most current package drawings, please see the Microchip Packaging Specification located at <http://www.microchip.com/packaging>

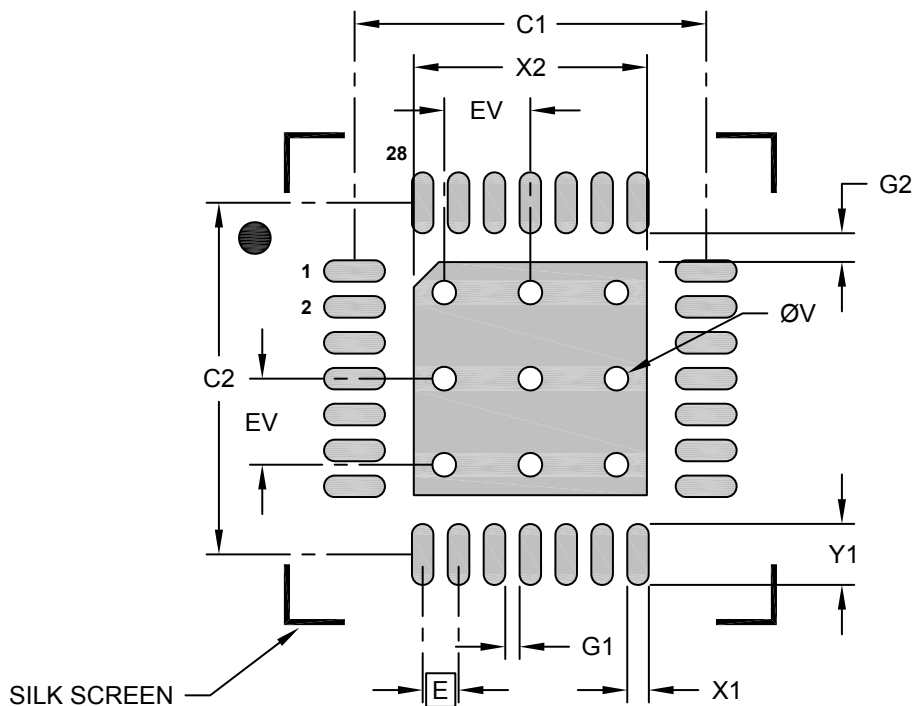

**RECOMMENDED LAND PATTERN**

Dimension Limits	Units	MILLIMETERS		
		MIN	NOM	MAX
Contact Pitch	E	0.50 BSC		
Optional Center Pad Width	X2			2.80
Optional Center Pad Length	Y2			2.80
Contact Pad Spacing	C1		3.25	
Contact Pad Spacing	C2		3.25	
Contact Pad Width (X28)	X1			0.30
Contact Pad Length (X28)	Y1			0.85
Contact Pad to Contact Pad (X24)	G1	0.20		
Contact Pad to Center Pad (X28)	G2	0.40		
Thermal Via Diameter	V		0.33	
Thermal Via Pitch	EV		1.20	

**Notes:**

1. Dimensioning and tolerancing per ASME Y14.5M  
BSC: Basic Dimension. Theoretically exact value shown without tolerances.
2. For best soldering results, thermal vias, if used, should be filled or tented to avoid solder loss during reflow process

**Package Outlines and Dimensions**

**32-Lead Very Thin Plastic Quad Flat, No Lead Package (RN) - 5x5 mm Body [VQFN]  
With 3.3x3.3 mm Exposed Pad, Punch Singulated; Formerly called QFN**

**Note:** For the most current package drawings, please see the Microchip Packaging Specification located at <http://www.microchip.com/packaging>

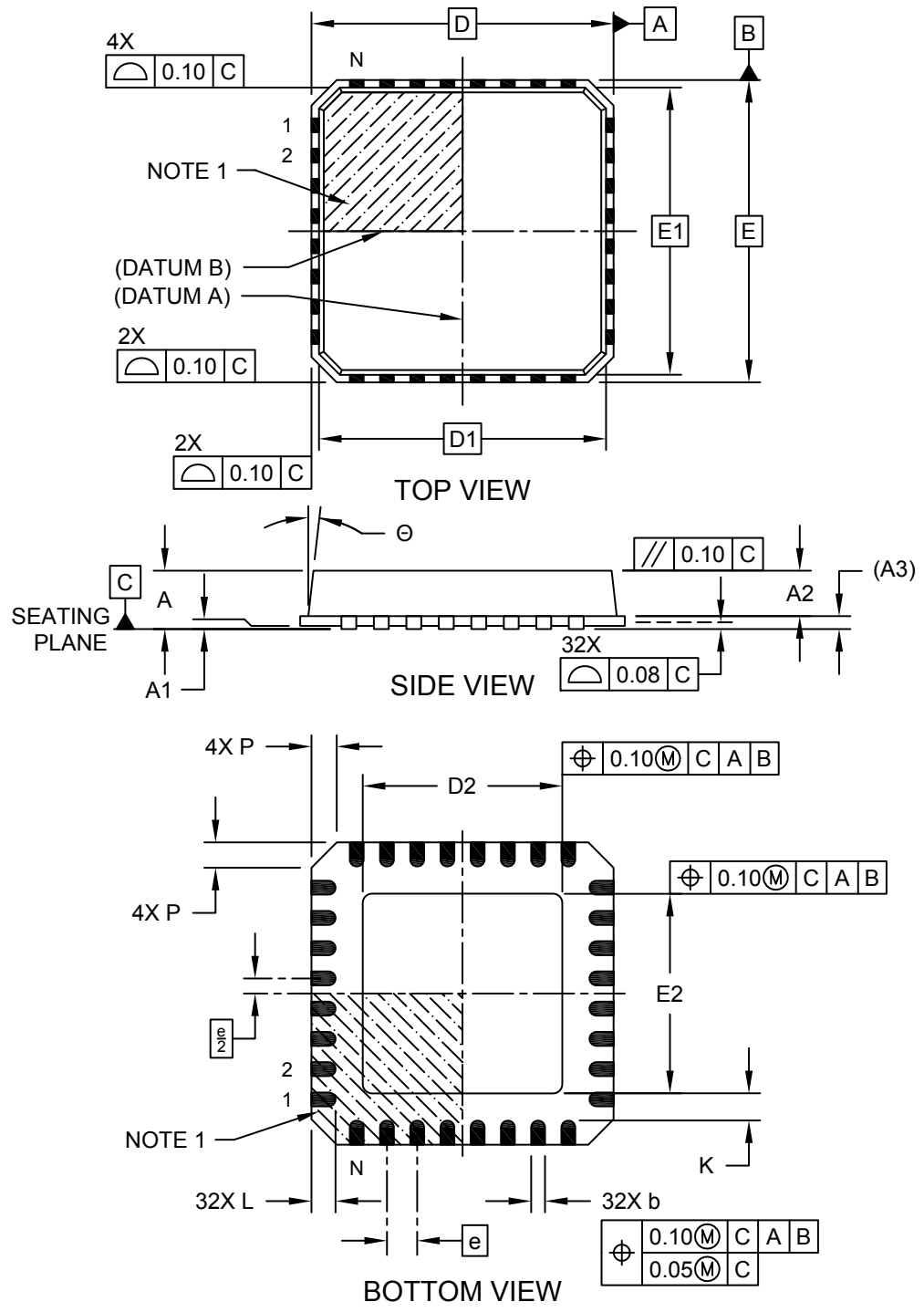

**Package Outlines and Dimensions**

**32-Lead Very Thin Plastic Quad Flat, No Lead Package (RN) - 5x5 mm Body [VQFN]  
With 3.3x3.3 mm Exposed Pad, Punch Singulated; Formerly called QFN**

**Note:** For the most current package drawings, please see the Microchip Packaging Specification located at <http://www.microchip.com/packaging>

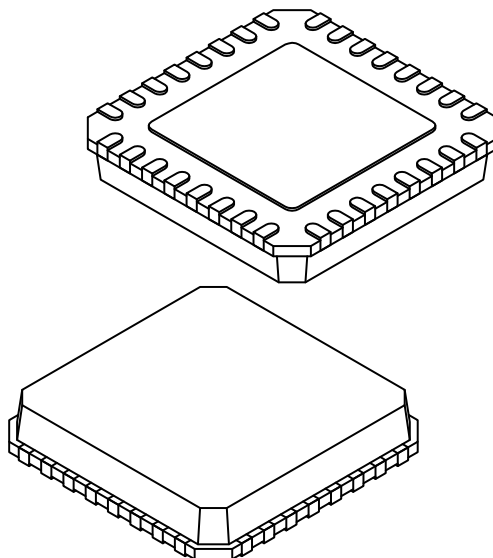

Units		MILLIMETERS		
Dimension Limits		MIN	NOM	MAX
Number of Terminals	N	32		
Pitch	e	0.50 BSC		
Overall Height	A	0.80	0.85	0.90
Standoff	A1	0.00	0.02	0.05
Mold Cap Height	A2	0.60	0.65	0.70
Terminal Thickness	(A3)	0.20 REF		
Overall Length	D	5.00 BSC		
Mold Cap length	D1	4.75 BSC		
Exposed Pad Length	D2	3.20	3.30	3.40
Overall Width	E	5.00 BSC		
Mold Cap Width	E1	4.75 BSC		
Exposed Pad Width	E2	3.20	3.30	3.40
Chamfer	P	0.24	0.42	0.60
Terminal Width	b	0.18	0.23	0.30
Terminal Length	L	0.30	0.40	0.50
Terminal-to-Exposed-Pad	K	0.25	-	-
Mold Draft Angle	Θ	0°	-	14°

**Notes:**

1. Pin 1 visual index feature may vary, but must be located within the hatched area.
2. Package is punch singulated
3. Dimensioning and tolerancing per ASME Y14.5M

BSC: Basic Dimension. Theoretically exact value shown without tolerances.

REF: Reference Dimension, usually without tolerance, for information purposes only.

---



---

## Footprint Outlines and Dimensions

---



---

### 32-Lead Very Thin Plastic Quad Flat, No Lead Package (RN) - 5x5 mm Body [VQFN] With 3.3x3.3 mm Exposed Pad, Punch Singulated; Formerly called QFN

**Note:** For the most current package drawings, please see the Microchip Packaging Specification located at <http://www.microchip.com/packaging>

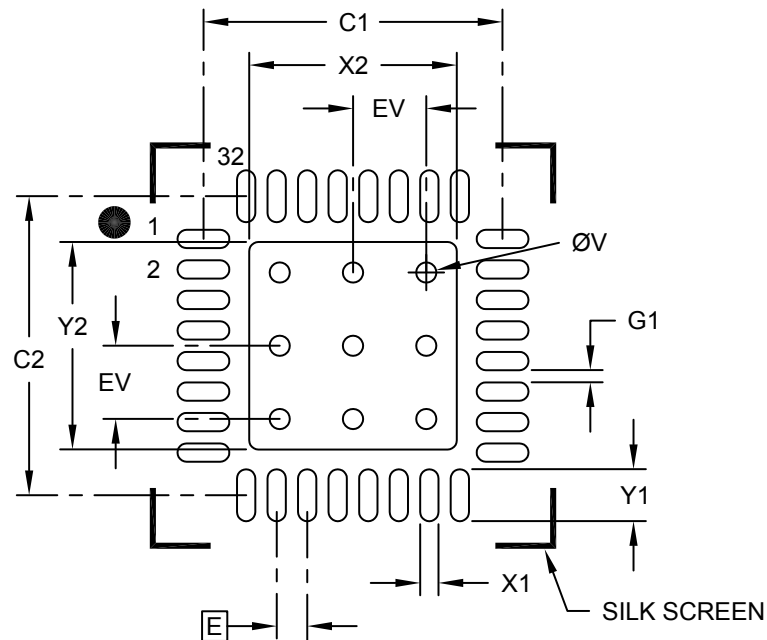

### RECOMMENDED LAND PATTERN

Dimension Limits	Units	MILLIMETERS		
		MIN	NOM	MAX
Contact Pitch	E	0.50 BSC		
Optional Center Pad Width	X2			3.40
Optional Center Pad Length	Y2			3.40
Contact Pad Spacing	C1		4.90	
Contact Pad Spacing	C2		4.90	
Contact Pad Width (X32)	X1			0.30
Contact Pad Length (X32)	Y1			0.85
Space Between Contacts (X28)	G1	0.20		
Thermal Via Diameter	V		0.33	
Thermal Via Pitch	EV		1.20	

**Notes:**

1. Dimensioning and tolerancing per ASME Y14.5M  
BSC: Basic Dimension. Theoretically exact value shown without tolerances.
2. For best soldering results, thermal vias, if used, should be filled or tented to avoid solder loss during reflow process

**Package Outlines and Dimensions**

**32-Lead Very Thin Plastic Quad Flat, No Lead Package (MQ) - 5x5x0.9 mm Body [VQFN]  
SMSC LEGACY SQFN**

**Note:** For the most current package drawings, please see the Microchip Packaging Specification located at <http://www.microchip.com/packaging>

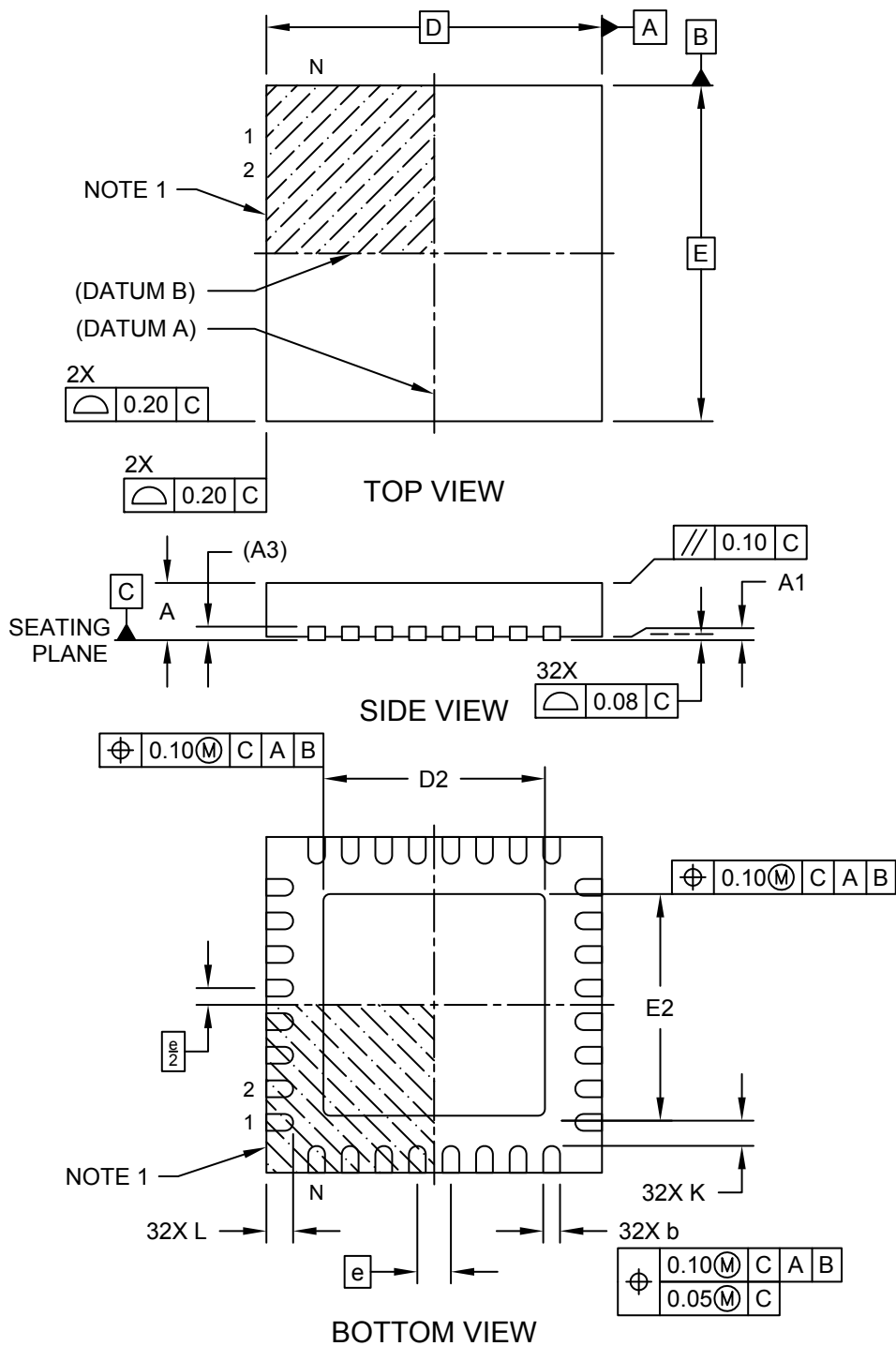



---



---

## Package Outlines and Dimensions

---



---

### 32-Lead Very Thin Plastic Quad Flat, No Lead Package (MQ) - 5x5x0.9 mm Body [VQFN] SMSC LEGACY SQFN

**Note:** For the most current package drawings, please see the Microchip Packaging Specification located at <http://www.microchip.com/packaging>

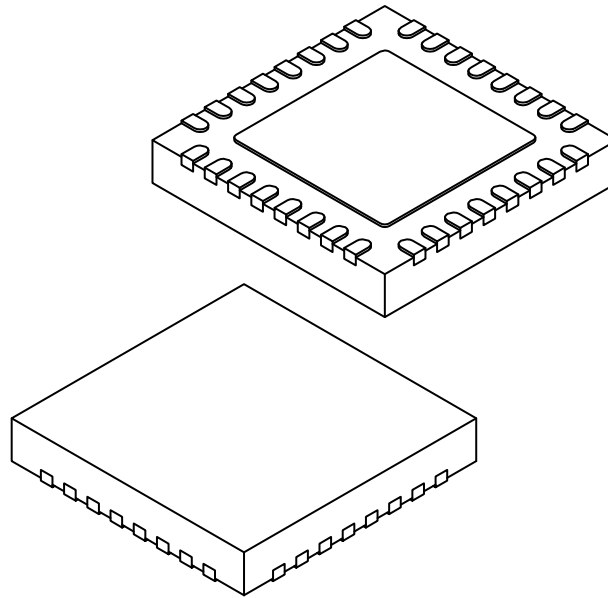

		Units	MILLIMETERS		
Dimension Limits			MIN	NOM	MAX
Number of Terminals	N		32		
Pitch	e		0.50 BSC		
Overall Height	A		0.80	0.90	1.00
Standoff	A1		0.00	0.02	0.05
Terminal Thickness	A3		0.20 REF		
Overall Width	E		5.00 BSC		
Exposed Pad Width	E2		3.20	3.30	3.40
Overall Length	D		5.00 BSC		
Exposed Pad Length	D2		3.20	3.30	3.40
Terminal Width	b		0.18	0.25	0.30
Terminal Length	L		0.35	0.40	0.45
Terminal-to-Exposed-Pad	K		0.20	-	-

**Notes:**

1. Pin 1 visual index feature may vary, but must be located within the hatched area.
2. Package is saw singulated
3. Dimensioning and tolerancing per ASME Y14.5M
  - BSC: Basic Dimension. Theoretically exact value shown without tolerances.
  - REF: Reference Dimension, usually without tolerance, for information purposes only.

**Footprint Outlines and Dimensions**

**32-Lead Very Thin Plastic Quad Flat, No Lead Package (MQ) - 5x5mm Body [VQFN]  
SMSC LEGACY SQFN**

**Note:** For the most current package drawings, please see the Microchip Packaging Specification located at <http://www.microchip.com/packaging>

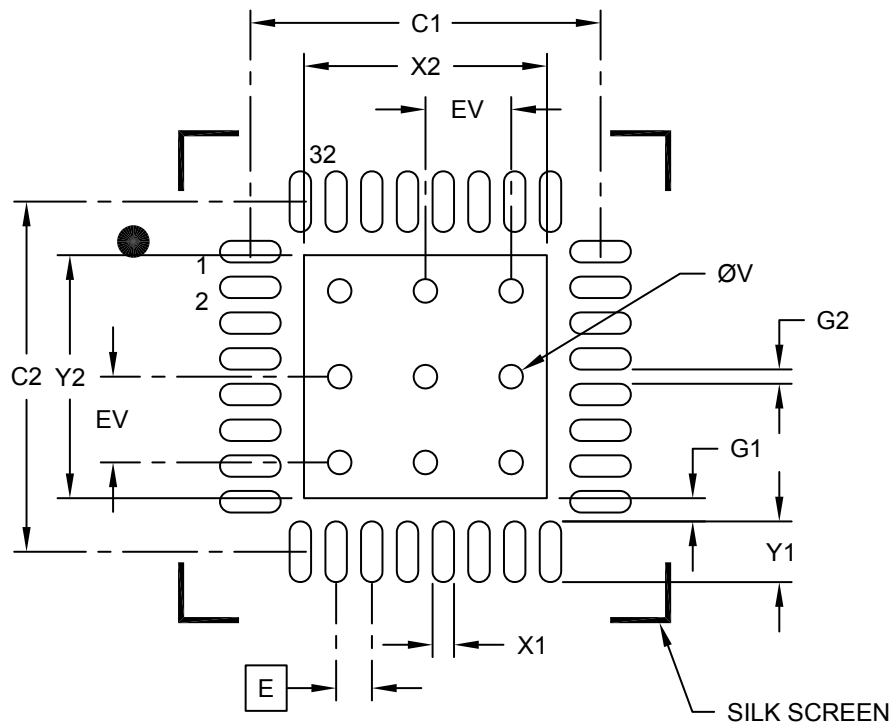

**RECOMMENDED LAND PATTERN**

Dimension Limits	Units	MILLIMETERS		
		MIN	NOM	MAX
Contact Pitch	E	0.50 BSC		
Optional Center Pad Width	X2			3.40
Optional Center Pad Length	Y2			3.40
Contact Pad Spacing	C1		4.90	
Contact Pad Spacing	C2		4.90	
Contact Pad Width (X32)	X1			0.30
Contact Pad Length (X32)	Y1			0.85
Contact Pad to Center Pad (X32)	G1	0.33		
Contact Pad to Contact Pad (X28)	G2	0.20		
Thermal Via Diameter	V		0.33	
Thermal Via Pitch	EV		1.20	

**Notes:**

1. Dimensioning and tolerancing per ASME Y14.5M  
BSC: Basic Dimension. Theoretically exact value shown without tolerances.
2. For best soldering results, thermal vias, if used, should be filled or tented to avoid solder loss during reflow process

**Package Outlines and Dimensions**

**32-Lead Very Thin Plastic Quad Flat, No Lead Package (S8) - 5x5x0.9 mm Body [VQFN]  
With 3.7x3.7 mm Exposed Pad**

**Note:** For the most current package drawings, please see the Microchip Packaging Specification located at <http://www.microchip.com/packaging>

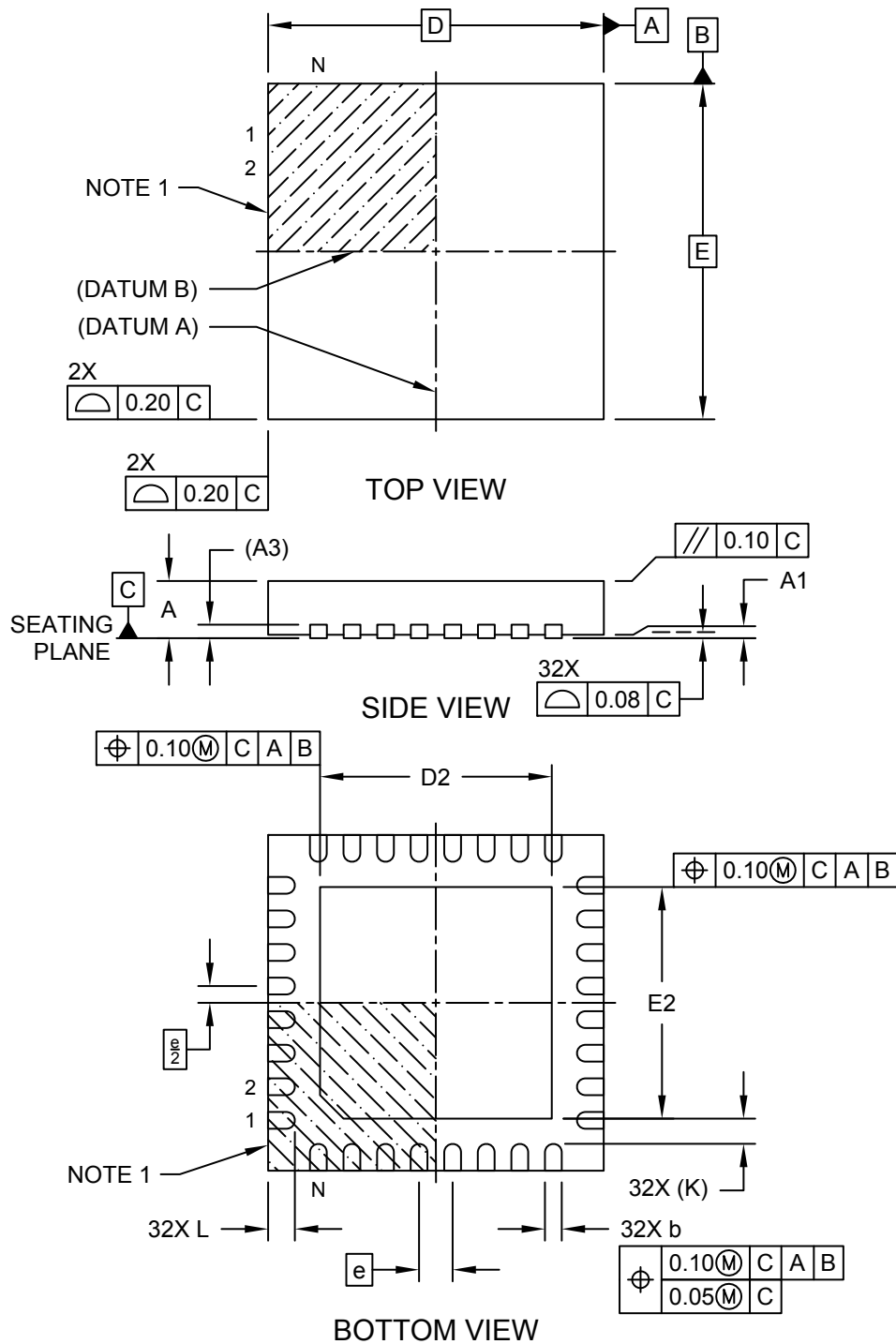

**Package Outlines and Dimensions**

**32-Lead Very Thin Plastic Quad Flat, No Lead Package (S8) - 5x5x0.9 mm Body [VQFN]  
With 3.7x3.7 mm Exposed Pad**

**Note:** For the most current package drawings, please see the Microchip Packaging Specification located at <http://www.microchip.com/packaging>

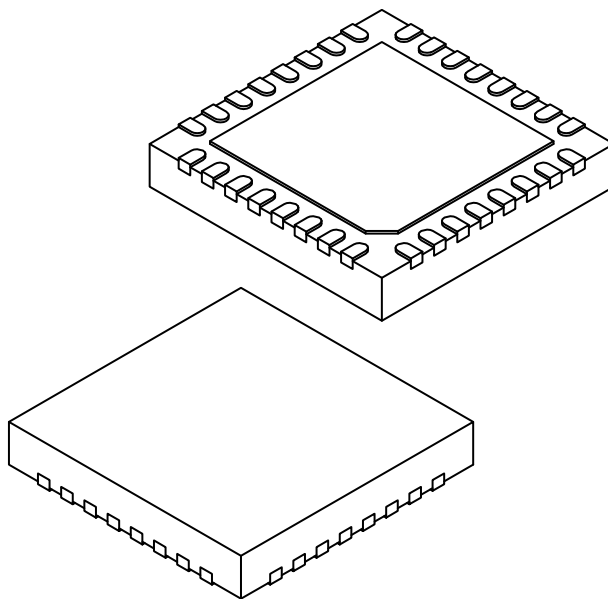

		Units	MILLIMETERS		
Dimension Limits			MIN	NOM	MAX
Number of Terminals	N		32		
Pitch	e		0.50 BSC		
Overall Height	A	0.80	0.85	0.90	
Standoff	A1	0.00	0.02	0.05	
Terminal Thickness	A3	0.20 REF			
Overall Width	E	5.00 BSC			
Exposed Pad Width	E2	3.60	3.70	3.80	
Overall Length	D	5.00 BSC			
Exposed Pad Length	D2	3.60	3.70	3.80	
Terminal Width	b	0.18	0.25	0.30	
Terminal Length	L	0.30	0.40	0.50	
Terminal-to-Exposed-Pad	K	0.25 REF			

**Notes:**

1. Pin 1 visual index feature may vary, but must be located within the hatched area.
2. Package is saw singulated
3. Dimensioning and tolerancing per ASME Y14.5M

BSC: Basic Dimension. Theoretically exact value shown without tolerances.

REF: Reference Dimension, usually without tolerance, for information purposes only.

---



---

## Footprint Outlines and Dimensions

---



---

### 32-Lead Very Thin Plastic Quad Flat, No Lead Package (S8) - 5x5 mm Body [VQFN] With 3.7x3.7 mm Exposed Pad

**Note:** For the most current package drawings, please see the Microchip Packaging Specification located at <http://www.microchip.com/packaging>

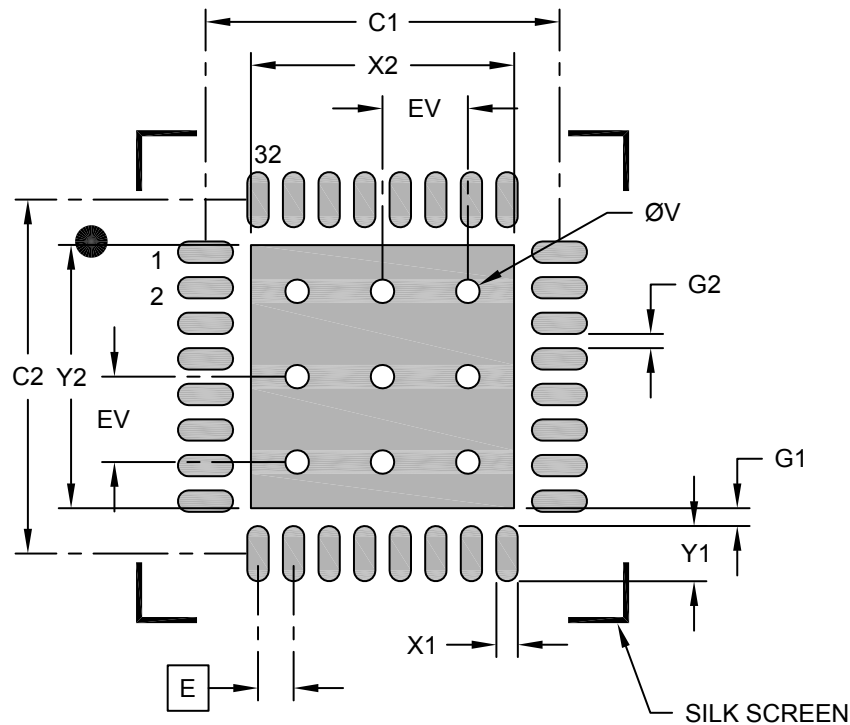

**RECOMMENDED LAND PATTERN**

	Units	MILLIMETERS		
		MIN	NOM	MAX
	Dimension Limits			
Contact Pitch	E	0.50 BSC		
Optional Center Pad Width	X2			3.70
Optional Center Pad Length	Y2			3.70
Contact Pad Spacing	C1		4.98	
Contact Pad Spacing	C2		4.98	
Contact Pad Width (X32)	X1			0.30
Contact Pad Length (X32)	Y1			0.78
Contact Pad to Center Pad (X32)	G1	0.25		
Contact Pad to Contact Pad (X28)	G2	0.20		
Thermal Via Diameter	V		0.33	
Thermal Via Pitch	EV		1.20	

**Notes:**

1. Dimensioning and tolerancing per ASME Y14.5M  
BSC: Basic Dimension. Theoretically exact value shown without tolerances.
2. For best soldering results, thermal vias, if used, should be filled or tented to avoid solder loss during reflow process

**Package Outlines and Dimensions**

**32-Lead Very Thin Plastic Quad Flat, No Lead Package (P5A) - 5x5x0.9 mm Body [VQFN] With 3.5x3.5 mm Exposed Pad**

**Note:** For the most current package drawings, please see the Microchip Packaging Specification located at <http://www.microchip.com/packaging>

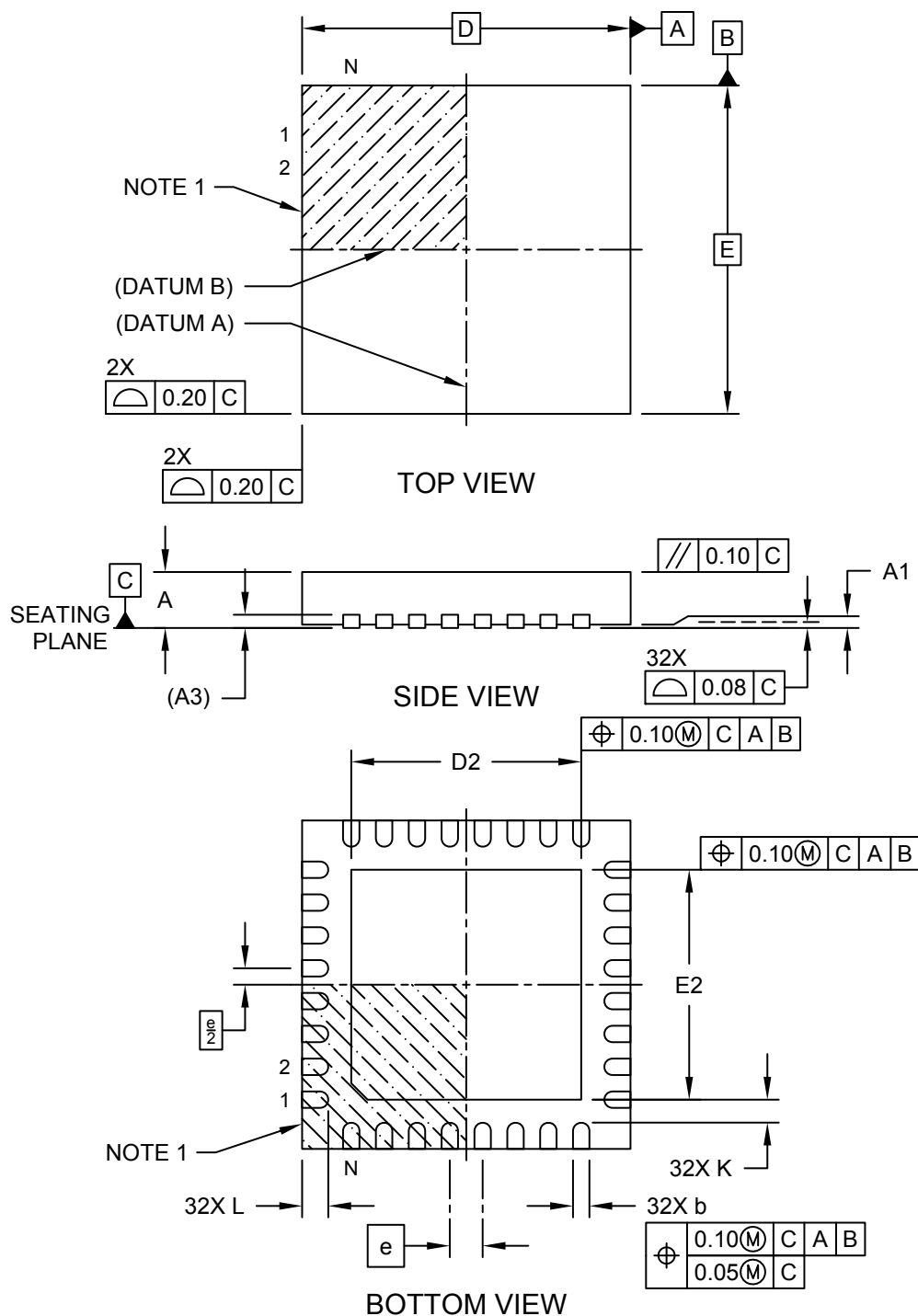

---



---

## Package Outlines and Dimensions

---



---

### 32-Lead Very Thin Plastic Quad Flat, No Lead Package (P5A) - 5x5x0.9 mm Body [VQFN] With 3.5x3.5 mm Exposed Pad

**Note:** For the most current package drawings, please see the Microchip Packaging Specification located at <http://www.microchip.com/packaging>

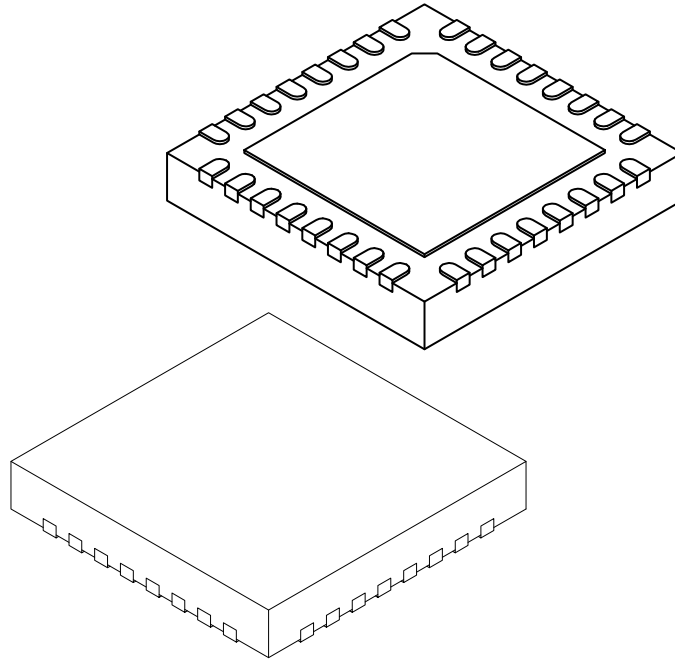

		Units	MILLIMETERS		
Dimension Limits			MIN	NOM	MAX
Number of Terminals	N		32		
Pitch	e		0.50 BSC		
Overall Height	A		0.80	0.85	0.90
Standoff	A1		0.00	0.02	0.05
Terminal Thickness	A3		0.20 REF		
Overall Width	E		5.00 BSC		
Exposed Pad Width	E2		3.40	3.50	3.60
Overall Length	D		5.00 BSC		
Exposed Pad Length	D2		3.40	3.50	3.60
Terminal Width	b		0.18	0.25	0.30
Terminal Length	L		0.35	0.40	0.45
Terminal-to-Exposed-Pad	K		0.20	-	-

**Notes:**

1. Pin 1 visual index feature may vary, but must be located within the hatched area.
2. Package is saw singulated
3. Dimensioning and tolerancing per ASME Y14.5M

BSC: Basic Dimension. Theoretically exact value shown without tolerances.

REF: Reference Dimension, usually without tolerance, for information purposes only.

**Footprint Outlines and Dimensions**

**32-Lead Very Thin Plastic Quad Flat, No Lead Package (P5A) - 5x5x0.9 mm Body [VQFN] With 3.5x3.5 mm Exposed Pad**

**Note:** For the most current package drawings, please see the Microchip Packaging Specification located at <http://www.microchip.com/packaging>

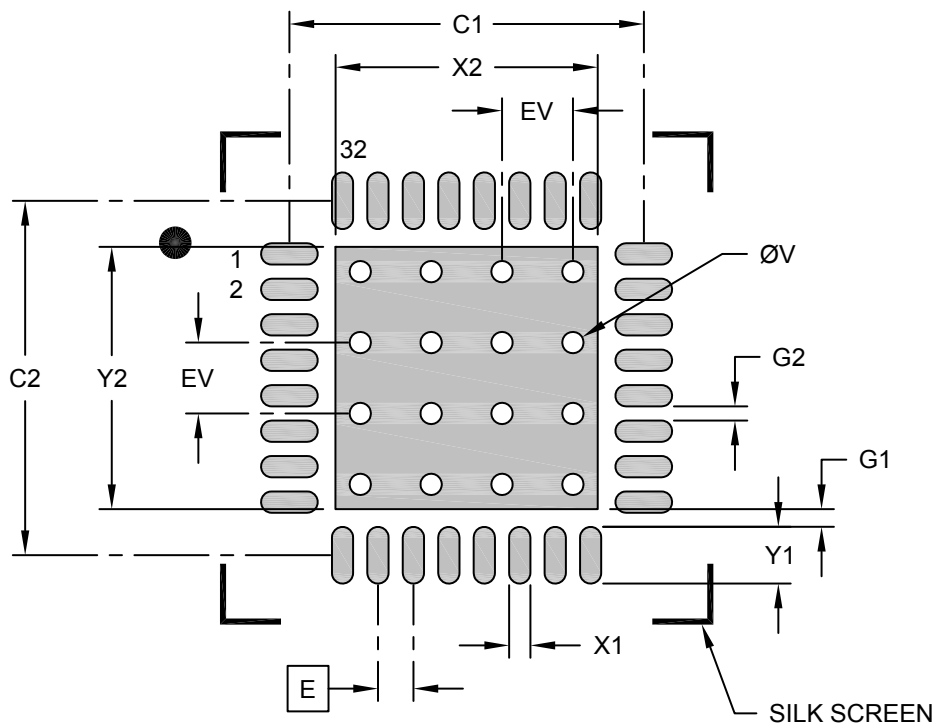

**RECOMMENDED LAND PATTERN**

Dimension Limits	Units	MILLIMETERS		
		MIN	NOM	MAX
Contact Pitch	E	0.50 BSC		
Optional Center Pad Width	X2			3.70
Optional Center Pad Length	Y2			3.70
Contact Pad Spacing	C1		5.00	
Contact Pad Spacing	C2		5.00	
Contact Pad Width (X32)	X1			0.30
Contact Pad Length (X32)	Y1			0.80
Contact Pad to Center Pad (X32)	G1	0.25		
Contact Pad to Contact Pad (X28)	G2	0.20		
Thermal Via Diameter	V		0.30	
Thermal Via Pitch	EV		1.00	

**Notes:**

1. Dimensioning and tolerancing per ASME Y14.5M  
BSC: Basic Dimension. Theoretically exact value shown without tolerances.
2. For best soldering results, thermal vias, if used, should be filled or tented to avoid solder loss during reflow process



**Package Outlines and Dimensions**

**32-Lead Very Thin Plastic Quad Flat, No Lead Package (PHA) - 6x6 mm Body [VQFN] Wettable Flanks, Multiple Exposed Pads**

**Note:** For the most current package drawings, please see the Microchip Packaging Specification located at <http://www.microchip.com/packaging>

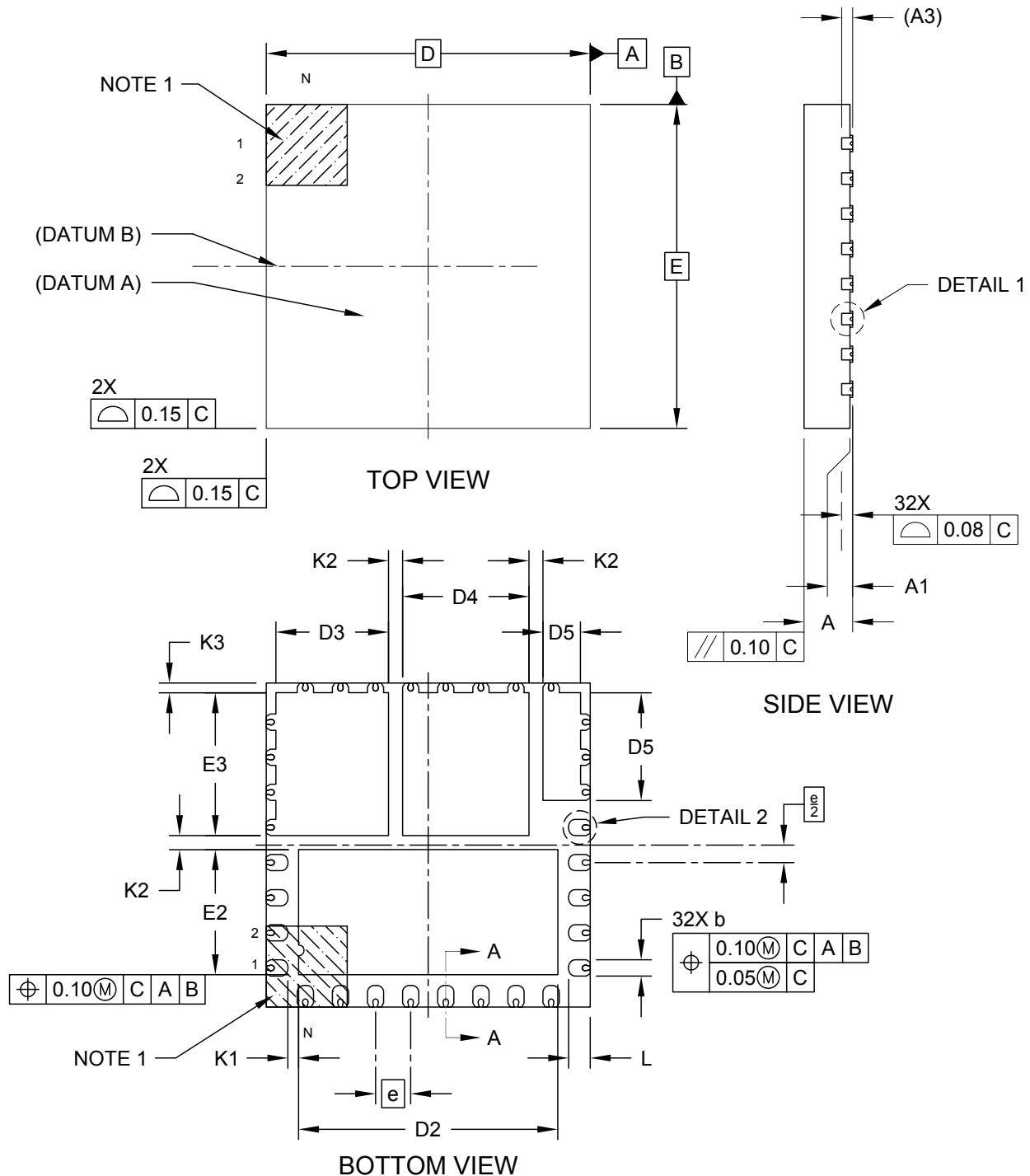

**Package Outlines and Dimensions**

**32-Lead Very Thin Plastic Quad Flat, No Lead Package (PHA) - 6x6 mm Body [VQFN]  
Wettable Flanks, Multiple Exposed Pads**

**Note:** For the most current package drawings, please see the Microchip Packaging Specification located at <http://www.microchip.com/packaging>

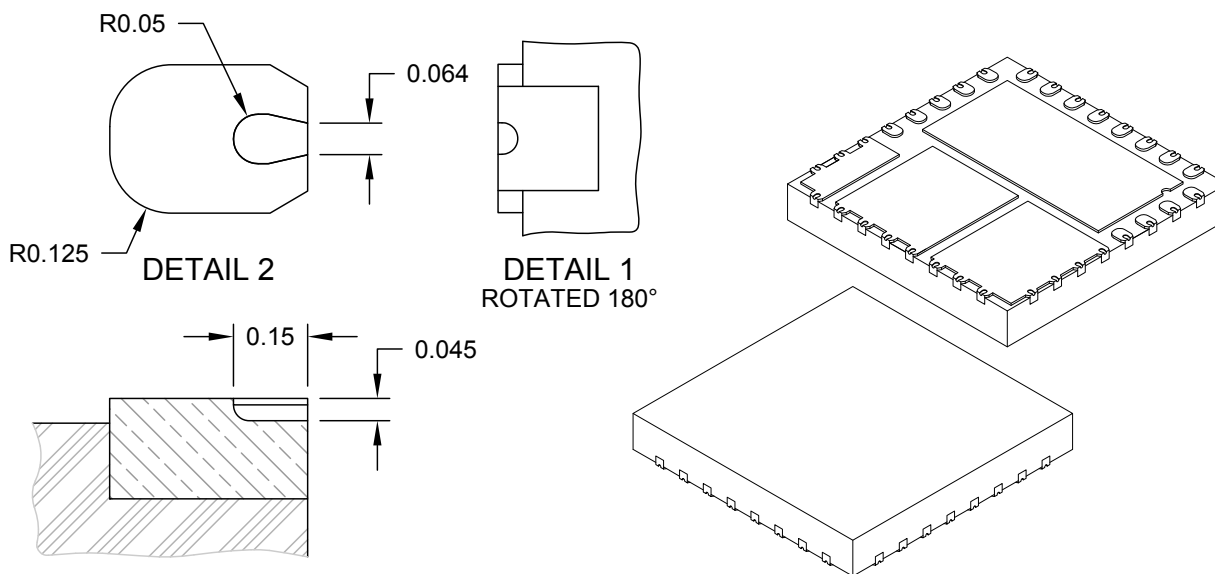

**SECTION A-A**

Dimension Limits	Units	MILLIMETERS		
		MIN	NOM	MAX
Number of Terminals	N	32		
Pitch	e	0.65 BSC		
Overall Height	A	0.80	0.85	0.90
Standoff	A1	0.00	0.02	0.05
Terminal Thickness	A3	0.203 REF		
Overall Length	D	6.00 BSC		
Overall Width	E	6.00 BSC		
Exposed Pad Length	D2	4.70	4.80	4.90
Exposed Pad Width	E2	2.215	2.315	2.415
Exposed Pad Length	D3	1.985	2.085	2.185
Exposed Pad Width	E3	2.545	2.645	2.745
Exposed Pad Length	D4	2.240	2.340	2.440
Exposed Pad Length	D5	0.595	0.695	0.795
Exposed Pad Width	E5	1.895	1.995	2.095
Terminal Width	b	0.25	0.30	0.35
Terminal Length	L	0.30	0.40	0.50
Terminal-to-Exposed Pad	K1	0.20	-	-
Exposed Pad-to-Exposed Pad	K2	0.20	0.26	-
Package Edgel-to-Exposed Pad	K3	0.18	-	-

**Notes:**

- Pin 1 visual index feature may vary, but must be located within the hatched area.
- Package is saw singulated
- Dimensioning and tolerancing per ASME Y14.5M

BSC: Basic Dimension. Theoretically exact value shown without tolerances.

REF: Reference Dimension, usually without tolerance, for information purposes only.

Microchip Technology Drawing C04-1196A Sheet 2 of 2

---



---

## Footprint Outlines and Dimensions

---



---

### 32-Lead Very Thin Plastic Quad Flat, No Lead Package (PHA) - 6x6 mm Body [VQFN] Wettable Flanks, Multiple Exposed Pads

**Note:** For the most current package drawings, please see the Microchip Packaging Specification located at <http://www.microchip.com/packaging>

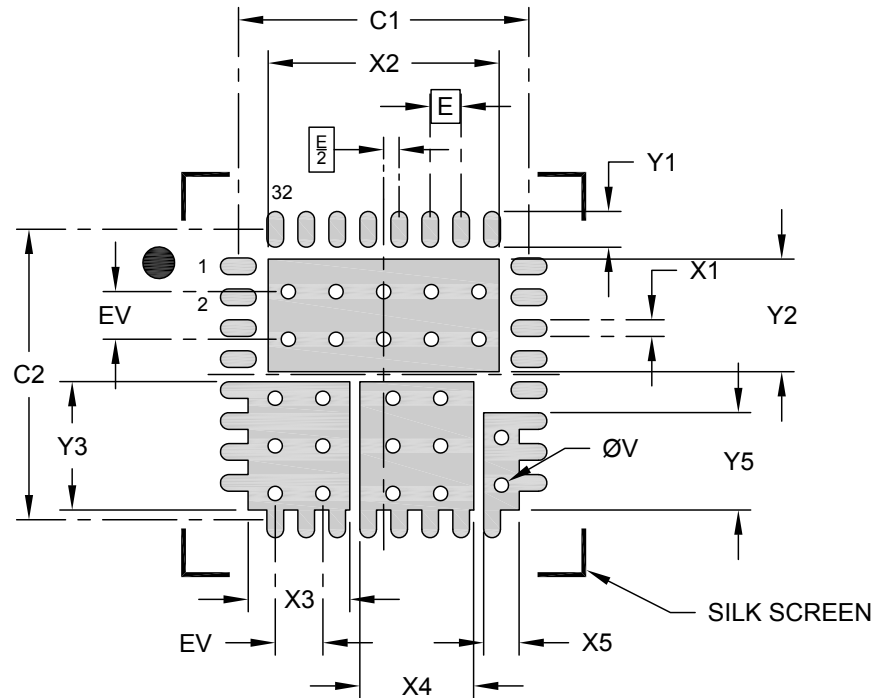

### RECOMMENDED LAND PATTERN

Dimension Limits	Units	MILLIMETERS		
		MIN	NOM	MAX
Contact Pitch	E	0.65 BSC		
Contact Pad Width (X32)	X1			0.35
Contact Pad Length (X32)	Y1			0.75
Contact Pad Spacing	C1	6.10		
Contact Pad Spacing	C2	6.10		
Inner Pad Length	X2			4.85
Inner Pad Width	Y2			2.36
Inner Pad Length	X3			2.13
Inner Pad Width	Y3			2.69
Inner Pad Length	X4			2.39
Inner Pad Length	X5			0.74
Inner Pad Width	Y5			2.04
Thermal Via Diameter (X26)	V	0.30		
Thermal Via Pitch	EV	1.00		

**Notes:**

- Dimensioning and tolerancing per ASME Y14.5M  
BSC: Basic Dimension. Theoretically exact value shown without tolerances.
- For best soldering results, thermal vias, if used, should be filled or tented to avoid solder loss during reflow process

**Package Outlines and Dimensions**

**36-Terminal Very Thin Plastic Quad Flatpack No-Lead (M2) - 6x6x1.0mm Body [VQFN]  
SMSC Legacy "Sawn Quad Flatpack No-Lead [SQFN]"**

**Note:** For the most current package drawings, please see the Microchip Packaging Specification located at <http://www.microchip.com/packaging>

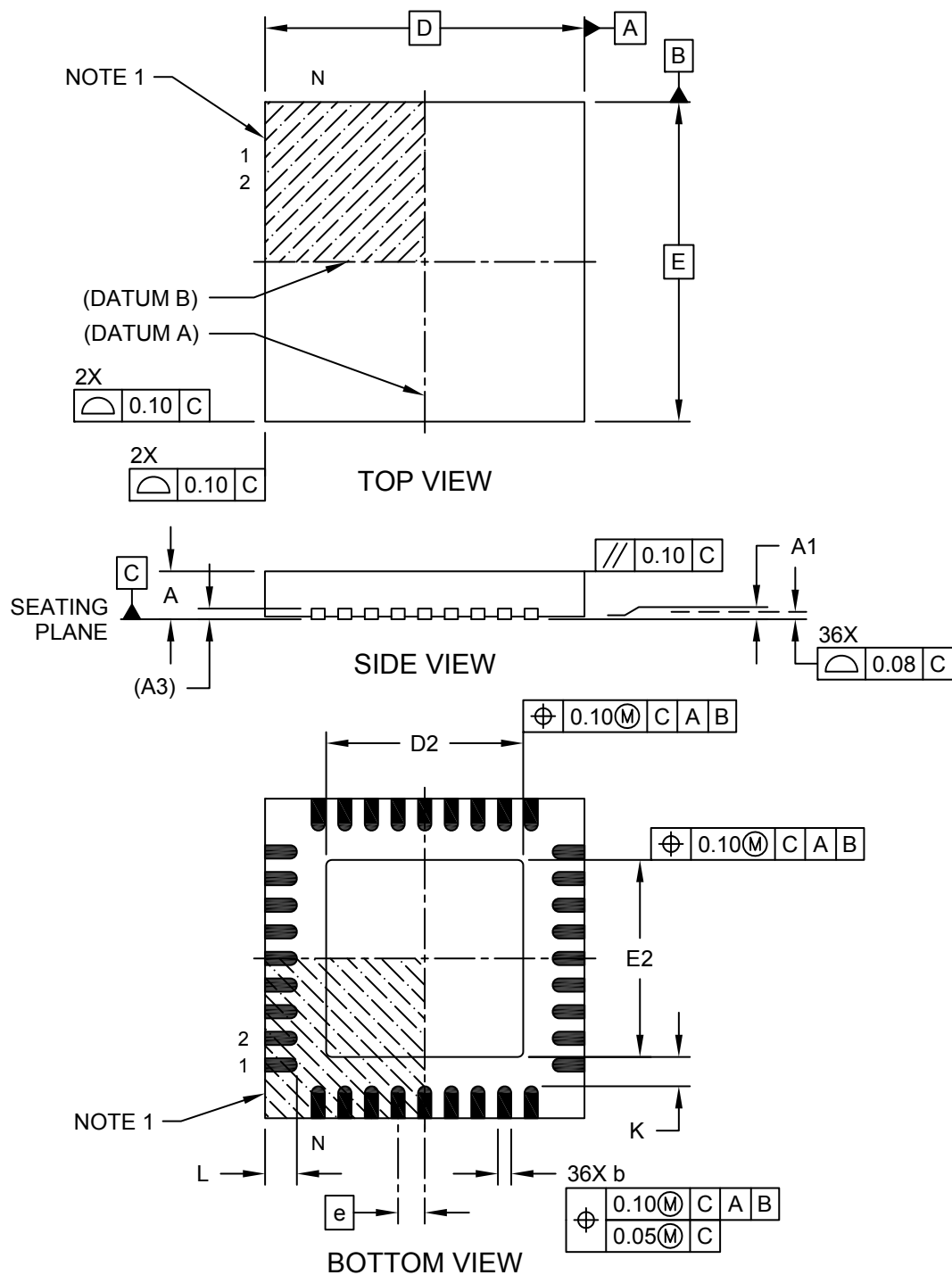

---



---

## Package Outlines and Dimensions

---



---

### 36-Terminal Very Thin Plastic Quad Flatpack No-Lead (M2) - 6x6x1.0mm Body [VQFN] SMSC Legacy "Sawn Quad Flatpack No-Lead [SQFN]"

**Note:** For the most current package drawings, please see the Microchip Packaging Specification located at <http://www.microchip.com/packaging>

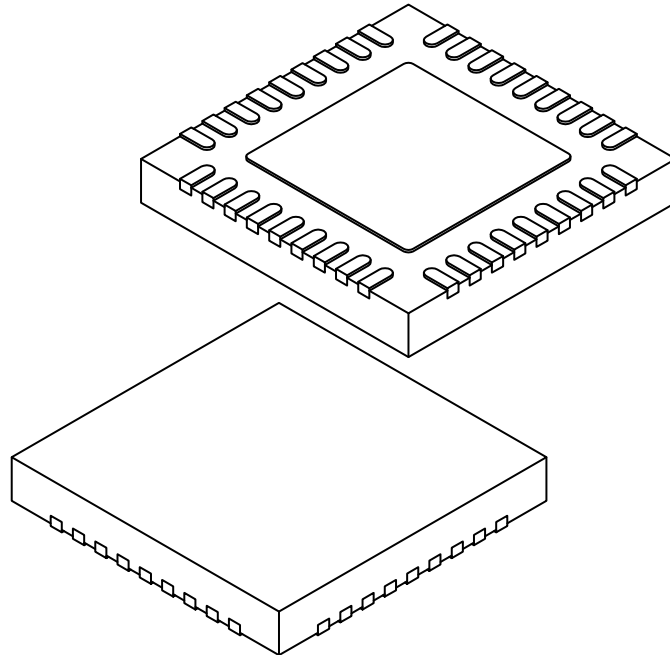

		Units	MILLIMETERS		
Dimension Limits			MIN	NOM	MAX
Number of Terminals	N		36		
Pitch	e		0.50 BSC		
Overall Height	A	0.80	0.90	1.00	
Standoff	A1	0.00	0.02	0.05	
Terminal Thickness	A3	0.20 REF			
Overall Width	E	6.00 BSC			
Exposed Pad Width	E2	3.60	3.70	3.80	
Overall Length	D	6.00 BSC			
Exposed Pad Length	D2	3.60	3.70	3.80	
Terminal Width	b	0.18	0.25	0.30	
Terminal Length	L	0.50	0.60	0.75	
Terminal-to-Exposed-Pad	K	0.45	0.55	-	

**Notes:**

1. Pin 1 visual index feature may vary, but must be located within the hatched area.
2. Package is saw singulated
3. Dimensioning and tolerancing per ASME Y14.5M

BSC: Basic Dimension. Theoretically exact value shown without tolerances.

REF: Reference Dimension, usually without tolerance, for information purposes only.

**Footprint Outlines and Dimensions**

**36-Terminal Very Thin Plastic Quad Flatpack No-Lead (M2) - 6x6x0.9 mm Body [VQFN]  
SMSC Legacy "Sawn Quad Flatpack No-Lead [SQFN]"**

**Note:** For the most current package drawings, please see the Microchip Packaging Specification located at <http://www.microchip.com/packaging>

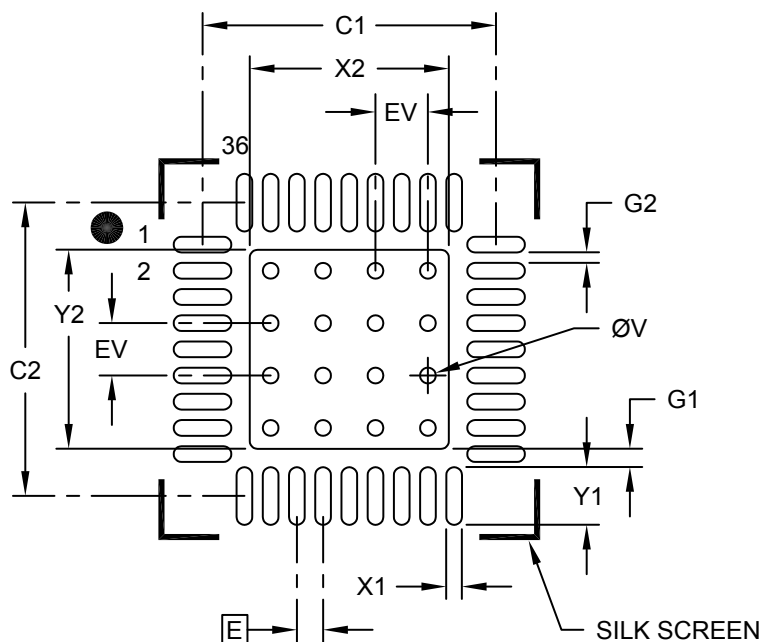

**RECOMMENDED LAND PATTERN**

Dimension Limits	Units	MILLIMETERS		
		MIN	NOM	MAX
Contact Pitch	E	0.50 BSC		
Optional Center Pad Width	X2			3.80
Optional Center Pad Length	Y2			3.80
Contact Pad Spacing	C1		5.60	
Contact Pad Spacing	C2		5.60	
Contact Pad Width (X36)	X1			0.30
Contact Pad Length (X36)	Y1			1.10
Contact Pad to Center Pad (X36)	G1	0.35		
Space Between Contact Pads (X32)	G2	0.20		
Thermal Via Diameter	V		0.30	
Thermal Via Pitch	EV		1.00	

Notes:

- Dimensioning and tolerancing per ASME Y14.5M  
BSC: Basic Dimension. Theoretically exact value shown without tolerances.
- For best soldering results, thermal vias, if used, should be filled or tented to avoid solder loss during reflow process

**Package Outlines and Dimensions**

**36-Terminal Very Thin Plastic Quad Flatpack No-Lead (AEN) - 6x6x1.0 mm Body [VQFN]  
SMSC Legacy "Sawn Quad Flatpack No-Lead [SQFN]"**

**Note:** For the most current package drawings, please see the Microchip Packaging Specification located at <http://www.microchip.com/packaging>

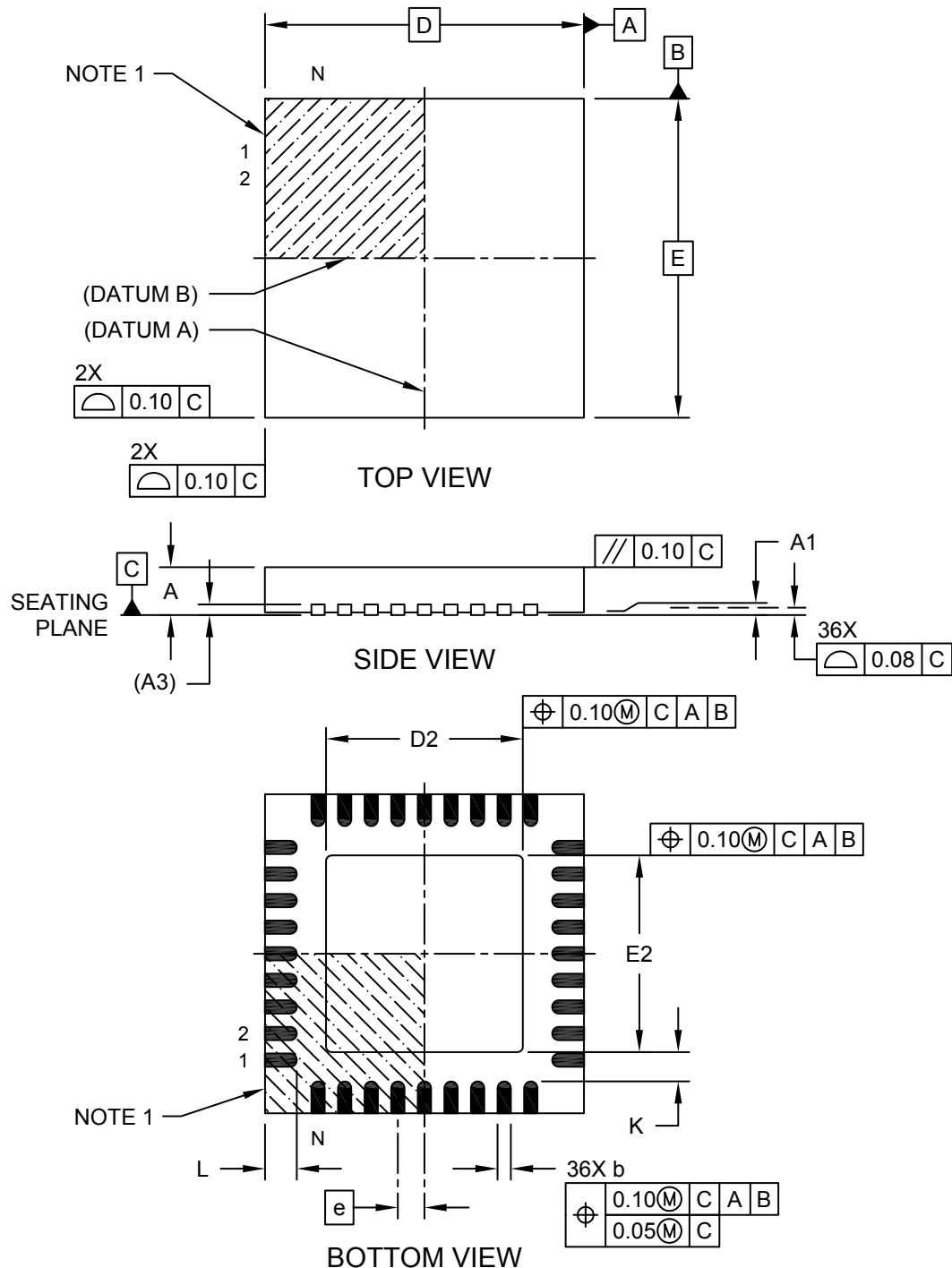

**Package Outlines and Dimensions**

**36-Terminal Very Thin Plastic Quad Flatpack No-Lead (AEN) - 6x6x1.0 mm Body [VQFN]  
SMSC Legacy "Sawn Quad Flatpack No-Lead [SQFN]"**

**Note:** For the most current package drawings, please see the Microchip Packaging Specification located at <http://www.microchip.com/packaging>

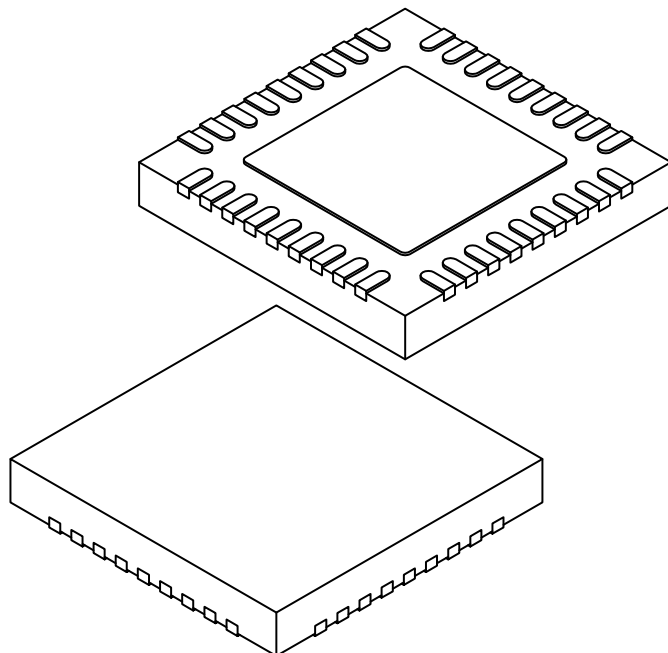

		MILLIMETERS		
Dimension Limits		MIN	NOM	MAX
Number of Terminals	N	36		
Pitch	e	0.50 BSC		
Overall Height	A	0.80	0.90	1.00
Standoff	A1	0.00	0.02	0.05
Terminal Thickness	A3	0.20 REF		
Overall Width	E	6.00 BSC		
Exposed Pad Width	E2	3.60	3.70	3.80
Overall Length	D	6.00 BSC		
Exposed Pad Length	D2	3.60	3.70	3.80
Terminal Width	b	0.18	0.25	0.30
Terminal Length	L	0.50	0.60	0.75
Terminal-to-Exposed-Pad	K	0.45	0.55	-

Notes:

1. Pin 1 visual index feature may vary, but must be located within the hatched area.
2. Package is saw singulated
3. Dimensioning and tolerancing per ASME Y14.5M

BSC: Basic Dimension. Theoretically exact value shown without tolerances.

REF: Reference Dimension, usually without tolerance, for information purposes only.



---



---

## Footprint Outlines and Dimensions

---



---

### 36-Terminal Very Thin Plastic Quad Flatpack No-Lead (AEN) - 6x6x0.9 mm Body [VQFN] SMSC Legacy "Sawn Quad Flatpack No-Lead [SQFN]"

**Note:** For the most current package drawings, please see the Microchip Packaging Specification located at <http://www.microchip.com/packaging>

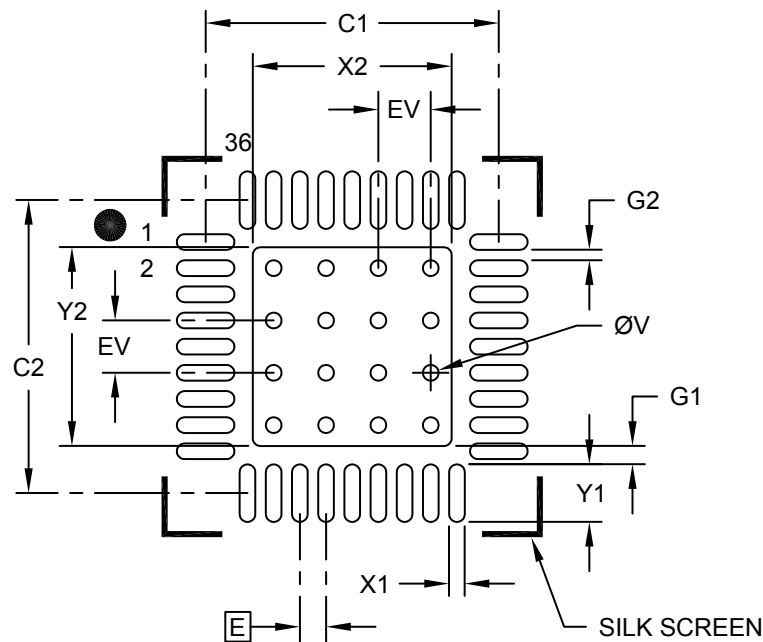

### RECOMMENDED LAND PATTERN

	Units	MILLIMETERS		
		MIN	NOM	MAX
	Dimension Limits			
Contact Pitch	E	0.50 BSC		
Optional Center Pad Width	X2			3.80
Optional Center Pad Length	Y2			3.80
Contact Pad Spacing	C1		5.60	
Contact Pad Spacing	C2		5.60	
Contact Pad Width (X36)	X1			0.30
Contact Pad Length (X36)	Y1			1.10
Contact Pad to Center Pad (X36)	G1	0.35		
Space Between Contact Pads (X32)	G2	0.20		
Thermal Via Diameter	V		0.30	
Thermal Via Pitch	EV		1.00	

**Notes:**

1. Dimensioning and tolerancing per ASME Y14.5M  
BSC: Basic Dimension. Theoretically exact value shown without tolerances.
2. For best soldering results, thermal vias, if used, should be filled or tented to avoid solder loss during reflow process

**Package Outlines and Dimensions**

**40-Lead Very Thin Quad Flat, No Lead Package (NPA) – 5.0x6.5 mm body [VQFN]  
With Dimpled Wettable Flanks**

**Note:** For the most current package drawings, please see the Microchip Packaging Specification located at <http://www.microchip.com/packaging>

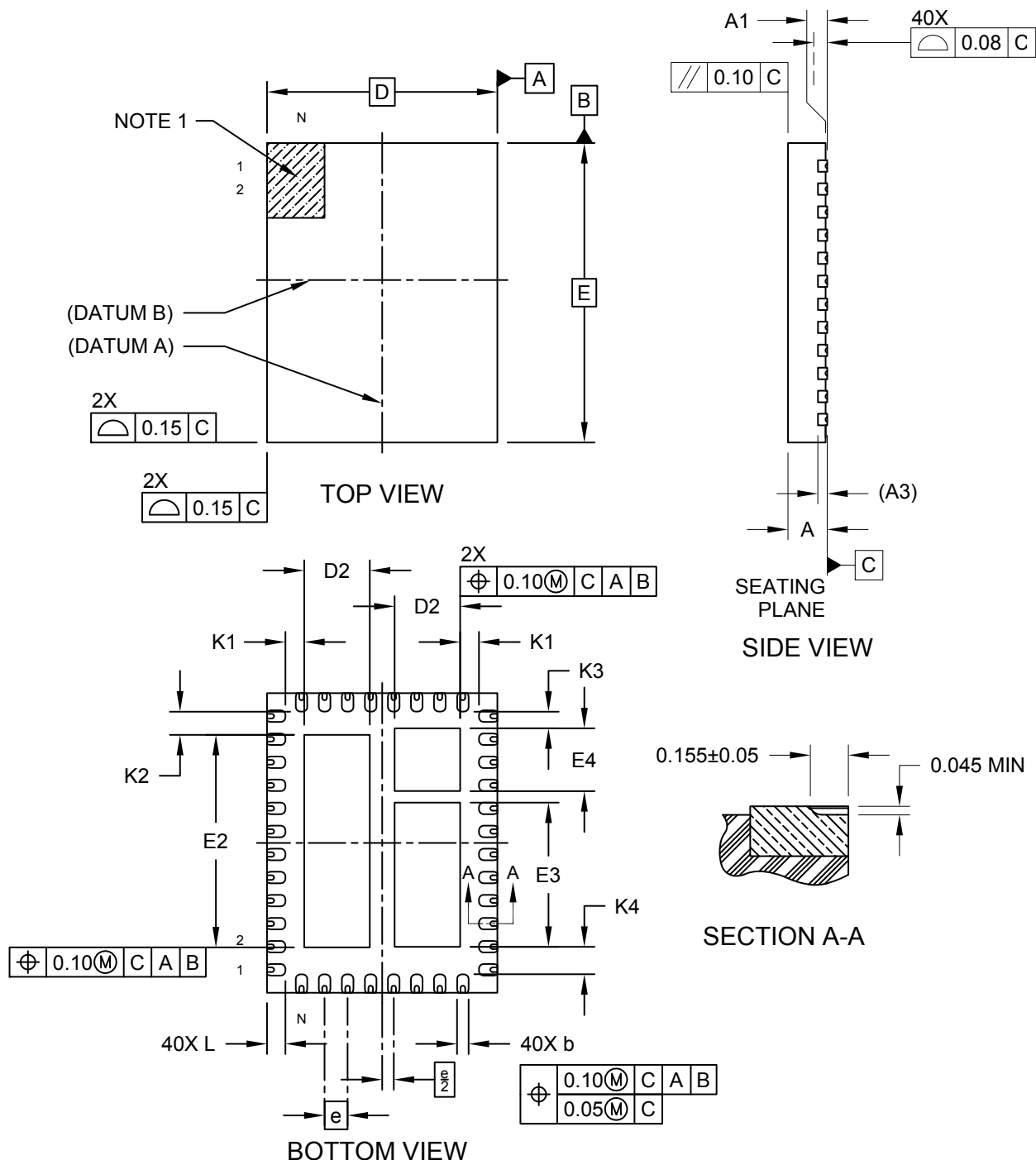

---



---

## Package Outlines and Dimensions

---



---

### 40-Lead Very Thin Quad Flat, No Lead Package (NPA) – 5.0x6.5 mm body [VQFN] With Dimpled Wettable Flanks

**Note:** For the most current package drawings, please see the Microchip Packaging Specification located at <http://www.microchip.com/packaging>

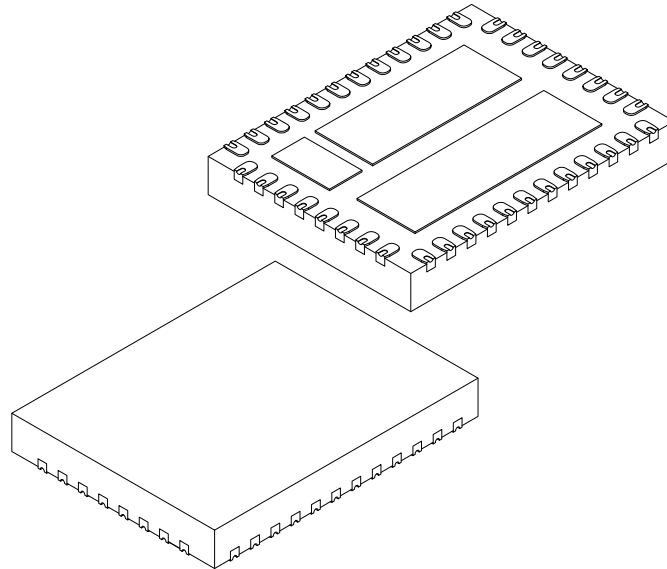

		Units	MILLIMETERS		
Dimension Limits			MIN	NOM	MAX
Number of Terminals	N		40		
Pitch	e		0.50 BSC		
Overall Height	A	0.80	0.85	0.90	
Standoff	A1	0.00	0.02	0.05	
Terminal Thickness	A3	0.203 REF			
Overall Length	D	5.00 BSC			
Exposed Pad Length	D2	1.32	1.42	1.52	
Overall Width	E	6.50 BSC			
Exposed Pad Width	E2	4.51	4.61	4.71	
Exposed Pad Width	E3	3.03	3.13	3.23	
Exposed Pad Width	E4	1.26	1.36	1.46	
Terminal Width	b	0.18	0.25	0.30	
Terminal Length	L	0.30	0.40	0.50	
Terminal-to-Exposed-Pad	K1	-	0.409	-	
Terminal-to-Exposed-Pad	K2	-	0.505	-	
Terminal-to-Exposed-Pad	K3	-	0.363	-	
Terminal-to-Exposed-Pad	K4	-	0.595	-	

**Notes:**

1. Pin 1 visual index feature may vary, but must be located within the hatched area.
2. Package is saw singulated
3. Dimensioning and tolerancing per ASME Y14.5M

BSC: Basic Dimension. Theoretically exact value shown without tolerances.

REF: Reference Dimension, usually without tolerance, for information purposes only.

**Footprint Outlines and Dimensions**

**40-Lead Very Thin Quad Flat, No Lead Package (NPA) – 5.0x6.5 mm body [VQFN]  
With Dimpled Wettable Flanks**

**Note:** For the most current package drawings, please see the Microchip Packaging Specification located at <http://www.microchip.com/packaging>

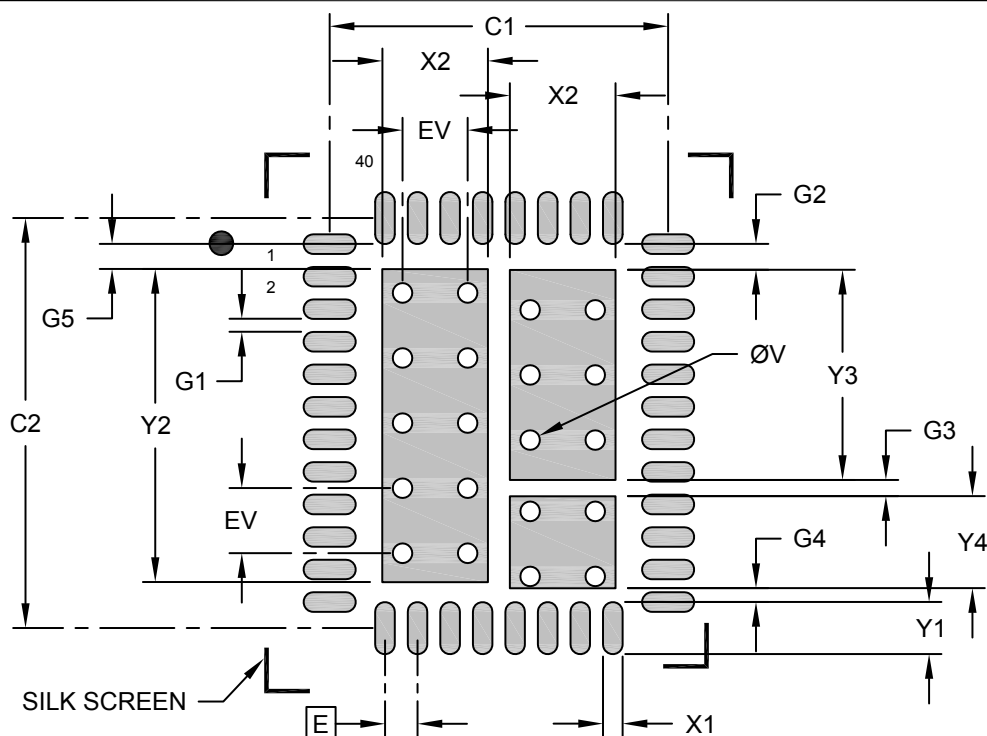

**RECOMMENDED LAND PATTERN**

Dimension Limits	Units	MILLIMETERS		
		MIN	NOM	MAX
Contact Pitch	E	0.50 BSC		
Contact Pad Width (X40)	X1			0.30
Contact Pad Length (X40)	Y1			0.80
Contact Pad Spacing	C1		5.20	
Contact Pad Spacing	C2		6.30	
Exposed Pad Width	X2			1.62
Exposed Pad Length	Y2			4.81
Exposed Pad Length	Y3			3.23
Exposed Pad Length	Y4			1.41
Pad to Pad	G1	0.20		
Pad to Pad	G2	0.40		
Pad to Pad	G3	0.25		
Pad to Pad	G4	0.20		
Pad to Pad	G5	0.38		
Thermal Via Diameter	V		0.30	
Thermal Via Pitch	EV		1.00	

**Notes:**

1. Dimensioning and tolerancing per ASME Y14.5M  
BSC: Basic Dimension. Theoretically exact value shown without tolerances.
2. For best soldering results, thermal vias, if used, should be filled or tented to avoid solder loss during reflow process

Microchip Technology Drawing C04-3206A

**Package Outlines and Dimensions**

**40-Lead Very Thin Plastic Quad Flat, No Lead Package (NHX) - 5x5 mm Body [VQFN]  
With 3.7x3.7 mm Exposed Pad and Wettable Flanks**

**Note:** For the most current package drawings, please see the Microchip Packaging Specification located at <http://www.microchip.com/packaging>

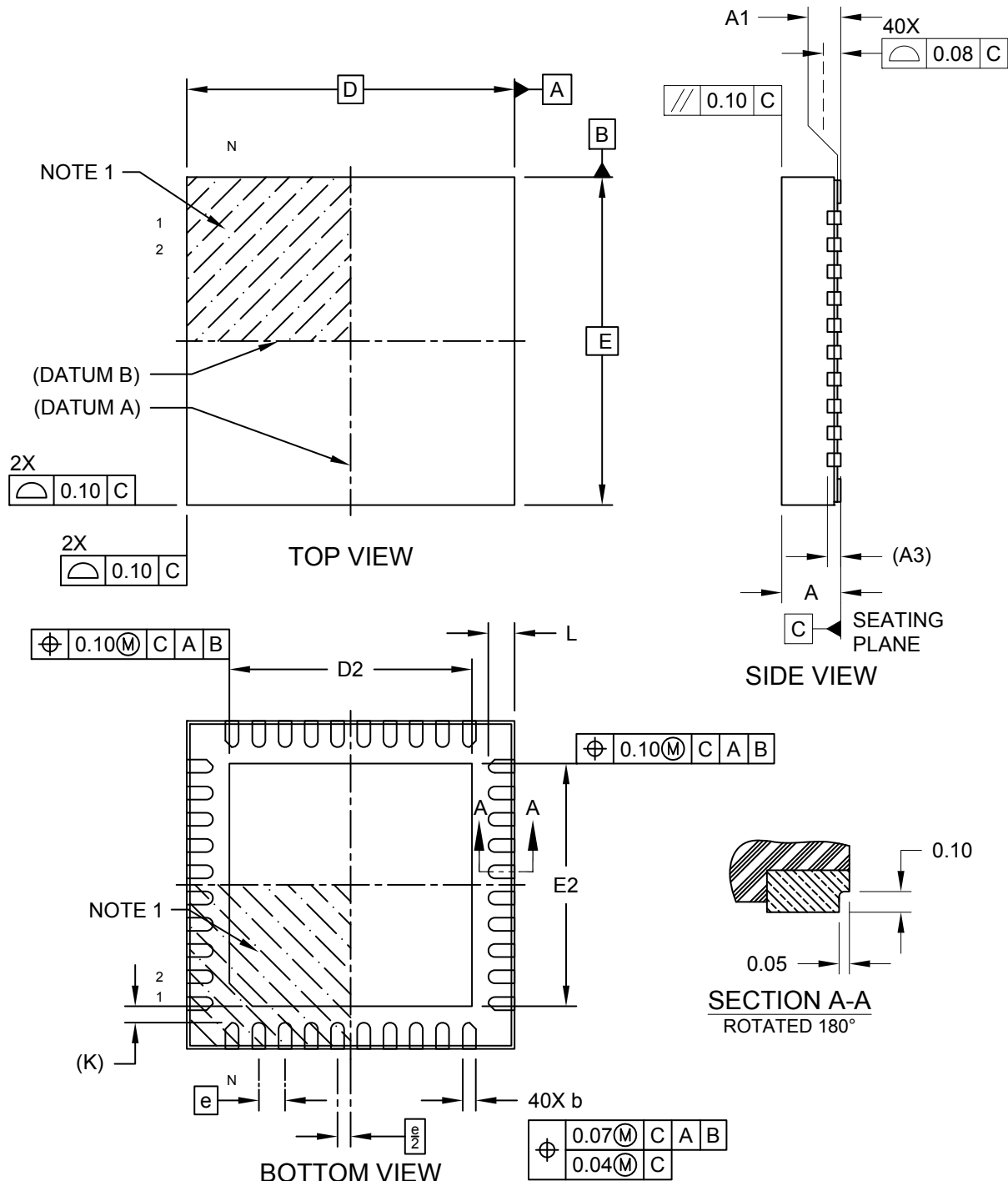

**Package Outlines and Dimensions**

**40-Lead Very Thin Plastic Quad Flat, No Lead Package (NHX) - 5x5 mm Body [VQFN]  
With 3.7x3.7 mm Exposed Pad and Wettable Flanks**

**Note:** For the most current package drawings, please see the Microchip Packaging Specification located at <http://www.microchip.com/packaging>

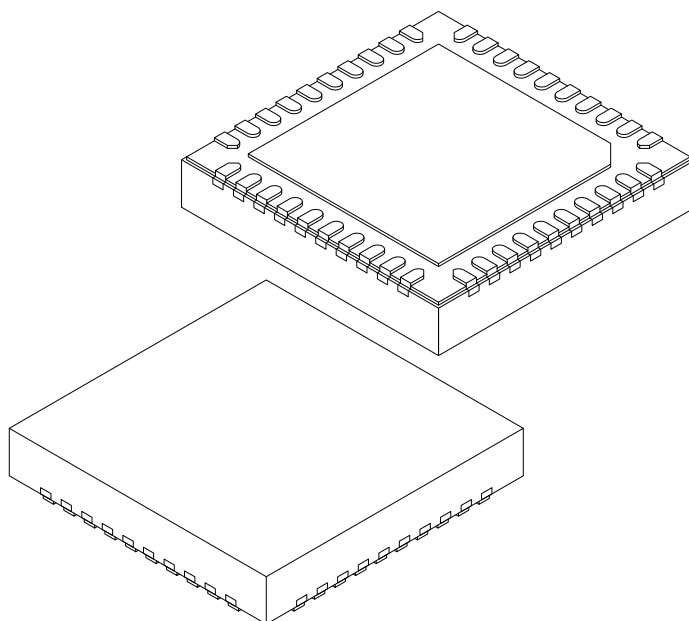

Units		MILLIMETERS		
Dimension Limits		MIN	NOM	MAX
Number of Terminals	N	40		
Pitch	e	0.40 BSC		
Overall Height	A	0.80	0.85	0.90
Standoff	A1	0.00	0.02	0.05
Terminal Thickness	A3	0.203 REF		
Overall Length	D	5.00 BSC		
Exposed Pad Length	D2	3.60	3.70	3.80
Overall Width	E	5.00 BSC		
Exposed Pad Width	E2	3.60	3.70	3.80
Terminal Width	b	0.15	0.20	0.25
Terminal Length	L	0.30	0.40	0.50
Terminal-to-Exposed-Pad	K	0.25 REF		

**Notes:**

1. Pin 1 visual index feature may vary, but must be located within the hatched area.
2. Package is saw singulated
3. Dimensioning and tolerancing per ASME Y14.5M

BSC: Basic Dimension. Theoretically exact value shown without tolerances.

REF: Reference Dimension, usually without tolerance, for information purposes only.

---



---

## Footprint Outlines and Dimensions

---



---

### 40-Lead Very Thin Plastic Quad Flat, No Lead Package (NHX) - 5x5 mm Body [VQFN] With 3.7x3.7 mm Exposed Pad and Wettable Flanks

**Note:** For the most current package drawings, please see the Microchip Packaging Specification located at <http://www.microchip.com/packaging>

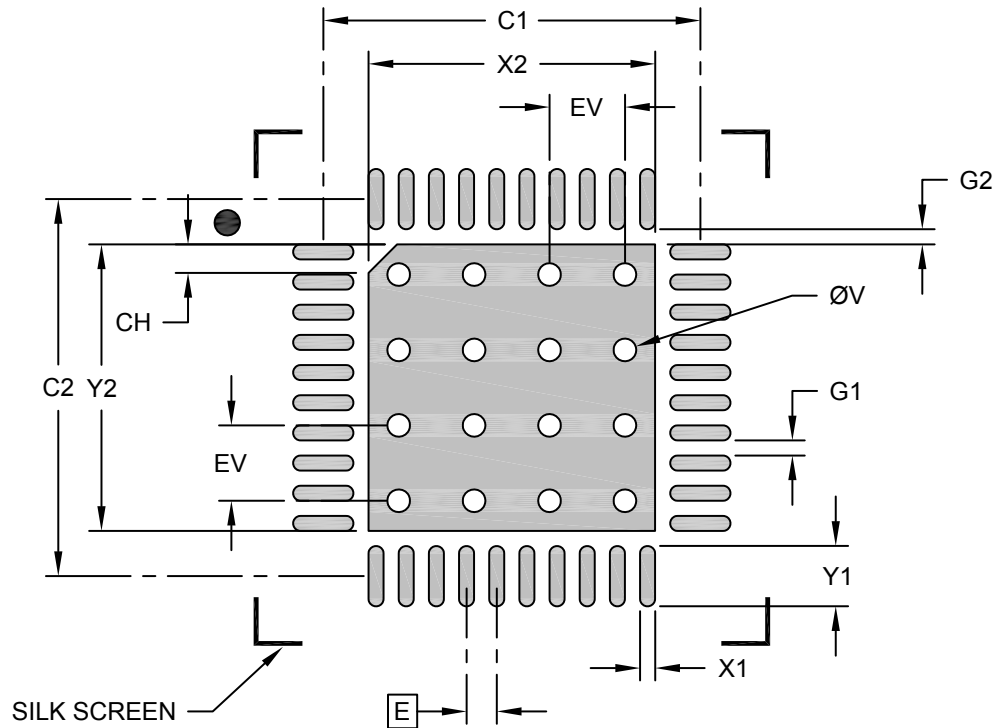

**RECOMMENDED LAND PATTERN**

Dimension Limits	Units	MILLIMETERS		
		MIN	NOM	MAX
Contact Pitch	E	0.40 BSC		
Optional Center Pad Width	X2			3.80
Optional Center Pad Length	Y2			3.80
Chamfer	CH		0.38	
Contact Pad Spacing	C1		5.00	
Contact Pad Spacing	C2		5.00	
Contact Pad Width (X40)	X1			0.20
Contact Pad Length (X40)	Y1			0.80
Contact Pad to Pad (X36)	G1	0.20		
Contact Pad to Center Pad (X40)	G2	0.20		
Thermal Via Diameter	V		0.30	
Thermal Via Pitch	EV		1.00	

**Notes:**

- Dimensioning and tolerancing per ASME Y14.5M  
BSC: Basic Dimension. Theoretically exact value shown without tolerances.
- For best soldering results, thermal vias, if used, should be filled or tented to avoid solder loss during reflow process

**Package Outlines and Dimensions**

**40-Lead Very Thin Plastic Quad Flat, No Lead Package (UW) - 6x6 mm Body [VQFN]  
Saw Singulated; ISSC Legacy Package**

**Note:** For the most current package drawings, please see the Microchip Packaging Specification located at <http://www.microchip.com/packaging>

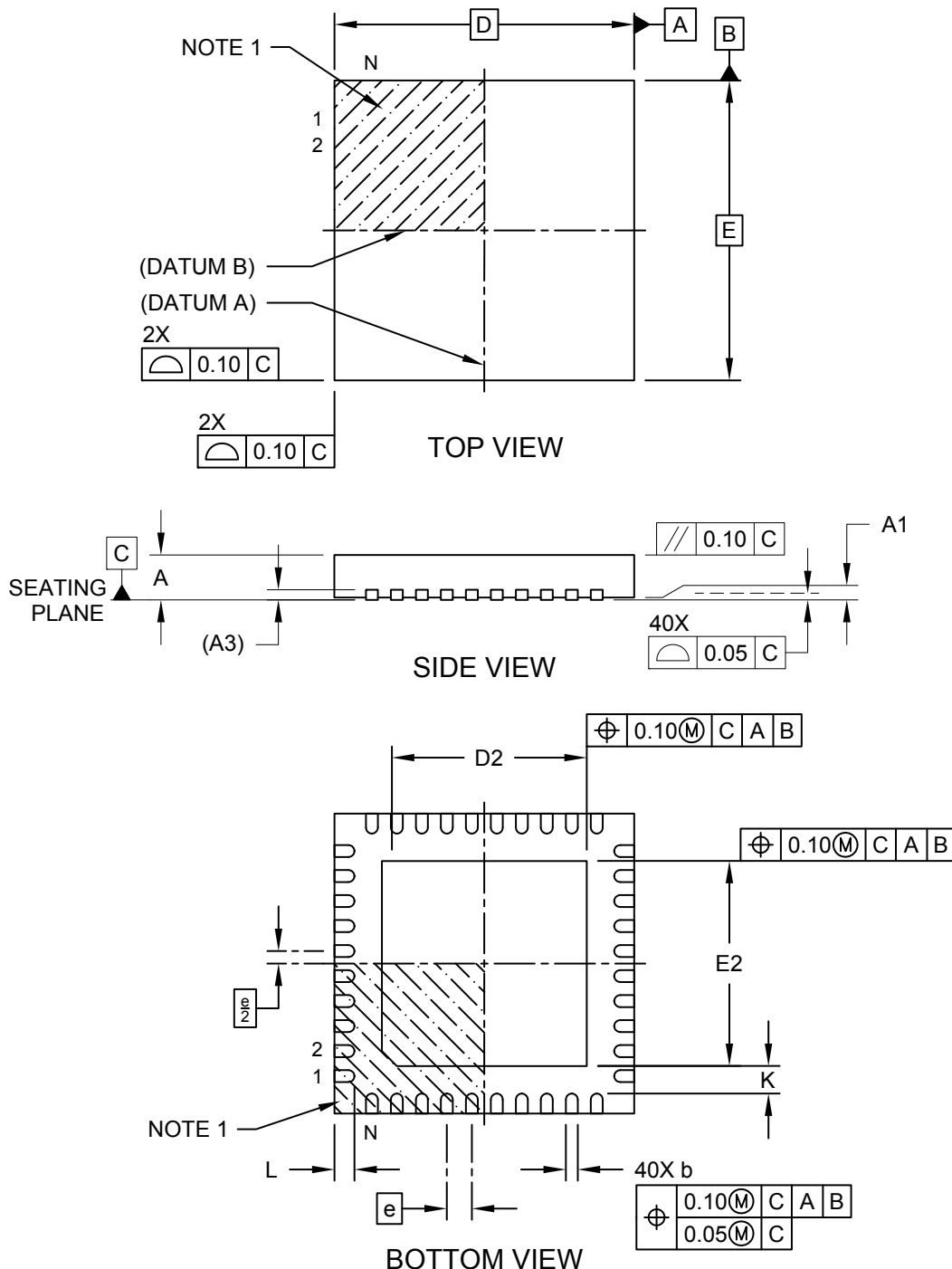



---



---

## Package Outlines and Dimensions

---



---

### 40-Lead Very Thin Plastic Quad Flat, No Lead Package (UW) - 6x6 mm Body [VQFN] Saw Singulated; ISSC Legacy Package

**Note:** For the most current package drawings, please see the Microchip Packaging Specification located at <http://www.microchip.com/packaging>

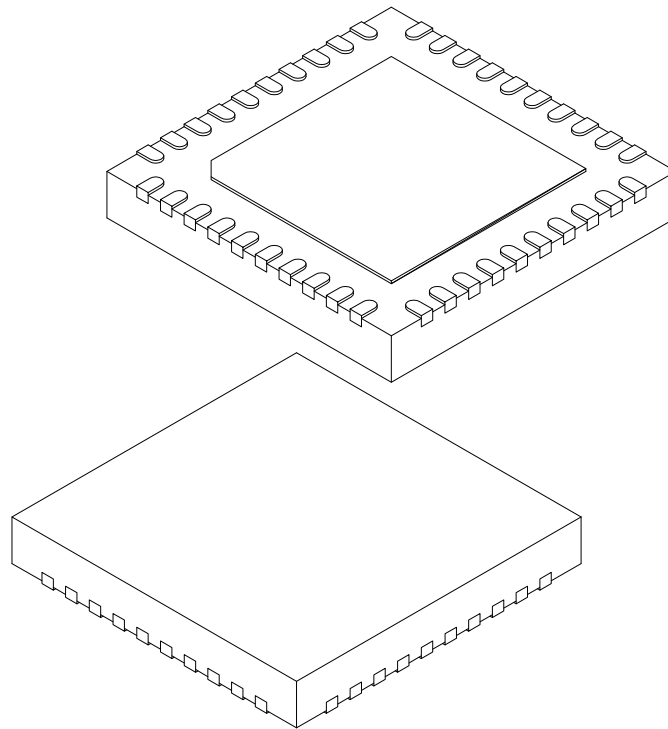

Dimension Limits	Units	MILLIMETERS		
		MIN	NOM	MAX
Number of Terminals	N	40		
Pitch	e	0.50 BSC		
Overall Height	A	0.80	0.85	0.90
Standoff	A1	0.00	0.02	0.05
Terminal Thickness	A3	0.203 REF		
Overall Length	D	6.00 BSC		
Exposed Pad Length	D2	3.95	4.10	4.25
Overall Width	E	6.00 BSC		
Exposed Pad Width	E2	3.95	4.10	4.25
Terminal Width	b	0.18	0.24	0.30
Terminal Length	L	0.30	0.40	0.50
Terminal-to-Exposed-Pad	K	0.20	-	-

**Notes:**

1. Pin 1 visual index feature may vary, but must be located within the hatched area.
2. Package is saw singulated
3. Dimensioning and tolerancing per ASME Y14.5M
  - BSC: Basic Dimension. Theoretically exact value shown without tolerances.
  - REF: Reference Dimension, usually without tolerance, for information purposes only.

**Footprint Outlines and Dimensions**

**40-Lead Very Thin Plastic Quad Flat, No Lead Package (UW) - 6x6 mm Body [VQFN]  
Saw Singulated; ISSC Legacy Package**

**Note:** For the most current package drawings, please see the Microchip Packaging Specification located at <http://www.microchip.com/packaging>

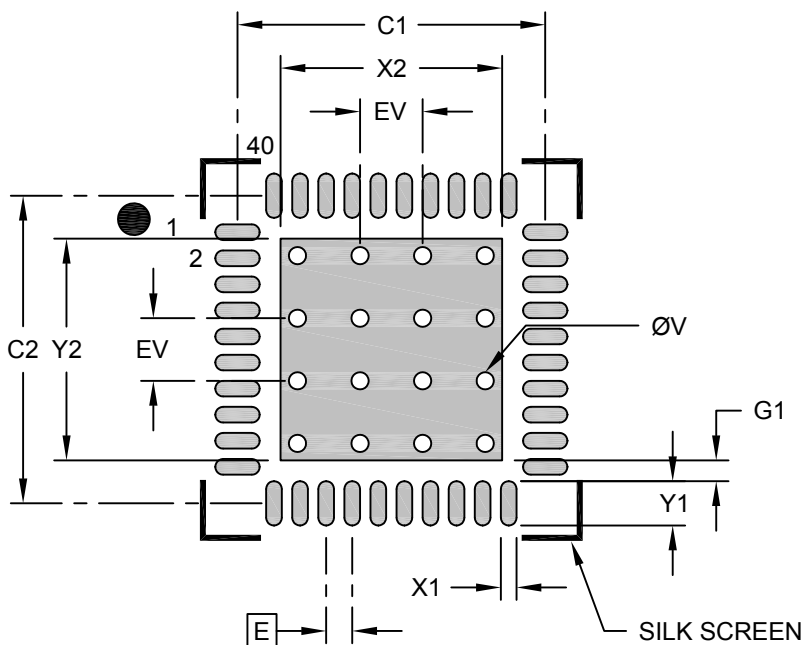

**RECOMMENDED LAND PATTERN**

Dimension Limits	Units	MILLIMETERS		
		MIN	NOM	MAX
Contact Pitch	E	0.50 BSC		
Optional Center Pad Width	X2			4.25
Optional Center Pad Length	Y2			4.25
Contact Pad Spacing	C1		5.90	
Contact Pad Spacing	C2		5.90	
Contact Pad Width (X40)	X1			0.30
Contact Pad Length (X40)	Y1			0.85
Contact Pad to Center Pad (X40)	G1	0.20		
Thermal Via Diameter	V		0.33	
Thermal Via Pitch	EV		1.20	

**Notes:**

1. Dimensioning and tolerancing per ASME Y14.5M  
BSC: Basic Dimension. Theoretically exact value shown without tolerances.
2. For best soldering results, thermal vias, if used, should be filled or tented to avoid solder loss during reflow process

**Package Outlines and Dimensions**

**40-Lead Very Thin Plastic Quad Flat, No Lead Package (VM) - 6x6 mm Body [VQFN]  
With 4.62x4.62 Exposed Pad; ISSC Legacy Package**

**Note:** For the most current package drawings, please see the Microchip Packaging Specification located at <http://www.microchip.com/packaging>

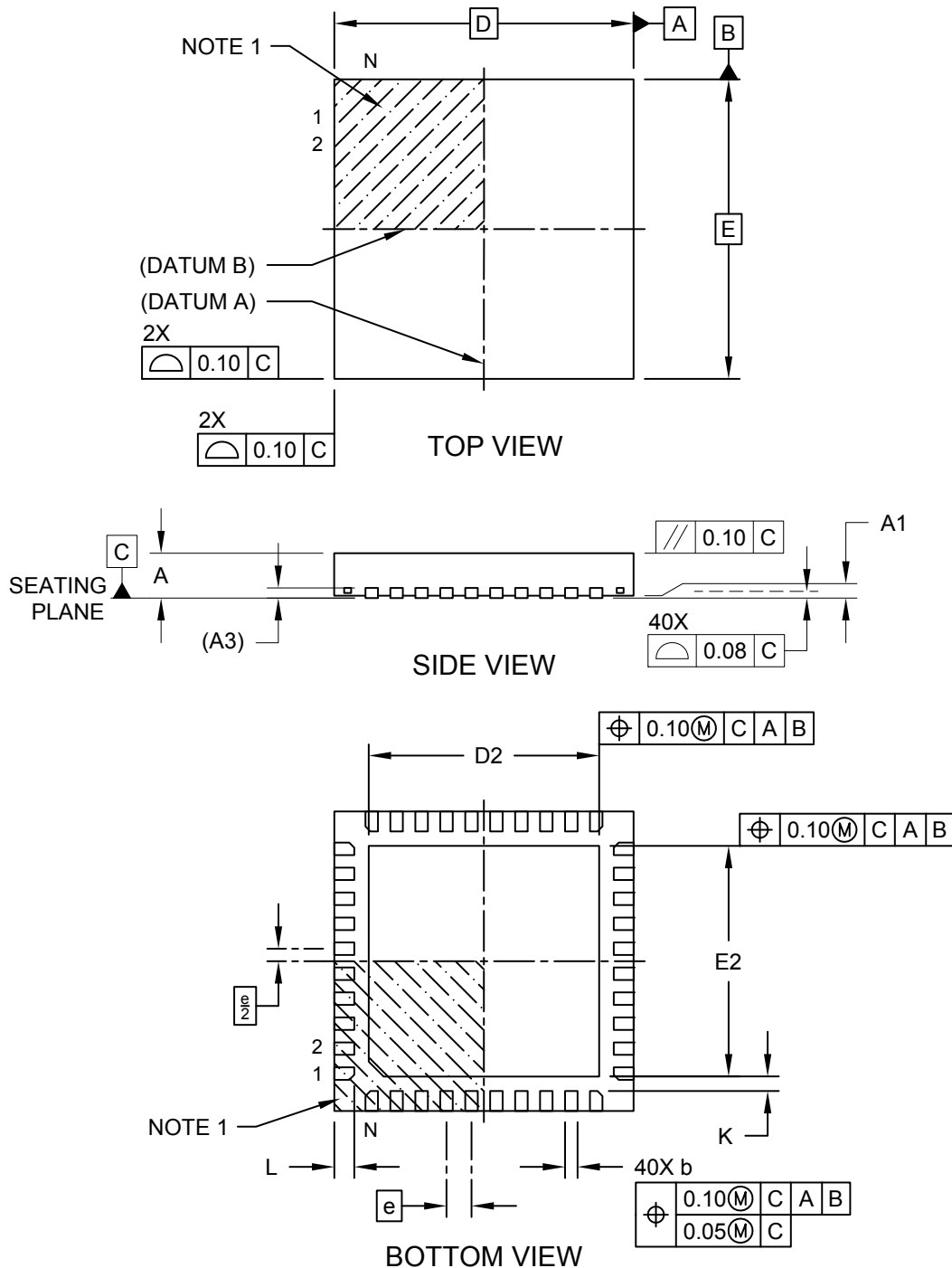

**Package Outlines and Dimensions**

**40-Lead Very Thin Plastic Quad Flat, No Lead Package (VM) - 6x6 mm Body [VQFN]  
With 4.62x4.62 Exposed Pad; ISSC Legacy Package**

**Note:** For the most current package drawings, please see the Microchip Packaging Specification located at <http://www.microchip.com/packaging>

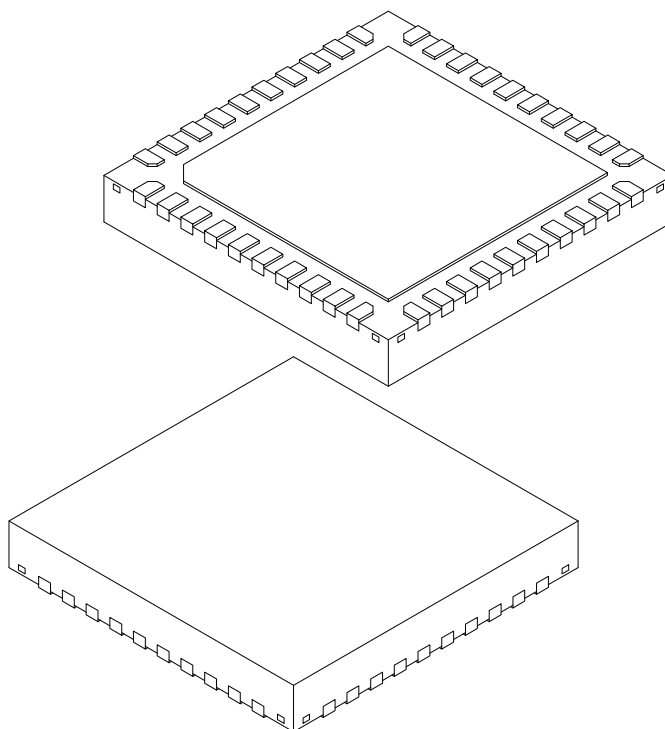

Dimension Limits	Units	MILLIMETERS		
		MIN	NOM	MAX
Number of Terminals	N	40		
Pitch	e	0.50 BSC		
Overall Height	A	0.80	0.85	0.90
Standoff	A1	0.00	0.02	0.05
Terminal Thickness	A3	0.203 REF		
Overall Length	D	6.00 BSC		
Exposed Pad Length	D2	4.52	4.62	4.72
Overall Width	E	6.00 BSC		
Exposed Pad Width	E2	4.52	4.62	4.72
Terminal Width	b	0.20	0.25	0.30
Terminal Length	L	0.35	0.40	0.45
Terminal-to-Exposed-Pad	K	0.20	-	-

**Notes:**

1. Pin 1 visual index feature may vary, but must be located within the hatched area.
2. Package is saw singulated
3. Dimensioning and tolerancing per ASME Y14.5M

BSC: Basic Dimension. Theoretically exact value shown without tolerances.

REF: Reference Dimension, usually without tolerance, for information purposes only.

---



---

## Footprint Outlines and Dimensions

---



---

### 40-Lead Very Thin Plastic Quad Flat, No Lead Package (VM) - 6x6 mm Body [VQFN] With 4.62x4.62 Exposed Pad; ISSC Legacy Package

**Note:** For the most current package drawings, please see the Microchip Packaging Specification located at <http://www.microchip.com/packaging>

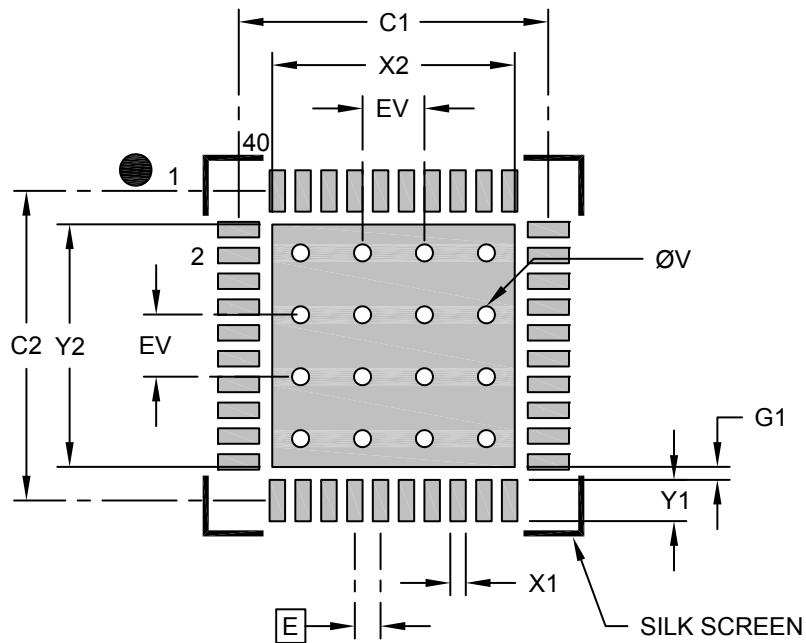

### RECOMMENDED LAND PATTERN

Dimension Limits	Units	MILLIMETERS		
		MIN	NOM	MAX
Contact Pitch	E	0.50 BSC		
Optional Center Pad Width	X2			4.70
Optional Center Pad Length	Y2			4.70
Contact Pad Spacing	C1		6.00	
Contact Pad Spacing	C2		6.00	
Contact Pad Width (X20)	X1			0.30
Contact Pad Length (X20)	Y1			0.80
Contact Pad to Center Pad (X20)	G1	0.20		
Thermal Via Diameter	V		0.33	
Thermal Via Pitch	EV		1.20	

**Notes:**

- Dimensioning and tolerancing per ASME Y14.5M  
BSC: Basic Dimension. Theoretically exact value shown without tolerances.
- For best soldering results, thermal vias, if used, should be filled or tented to avoid solder loss during reflow process

**Package Outlines and Dimensions**

**40-Lead Very Thin Plastic Quad Flat, No Lead Package (PQA) - 6x6 mm Body [VQFN]  
With 4.1x4.1 mm Exposed Pad**

**Note:** For the most current package drawings, please see the Microchip Packaging Specification located at <http://www.microchip.com/packaging>

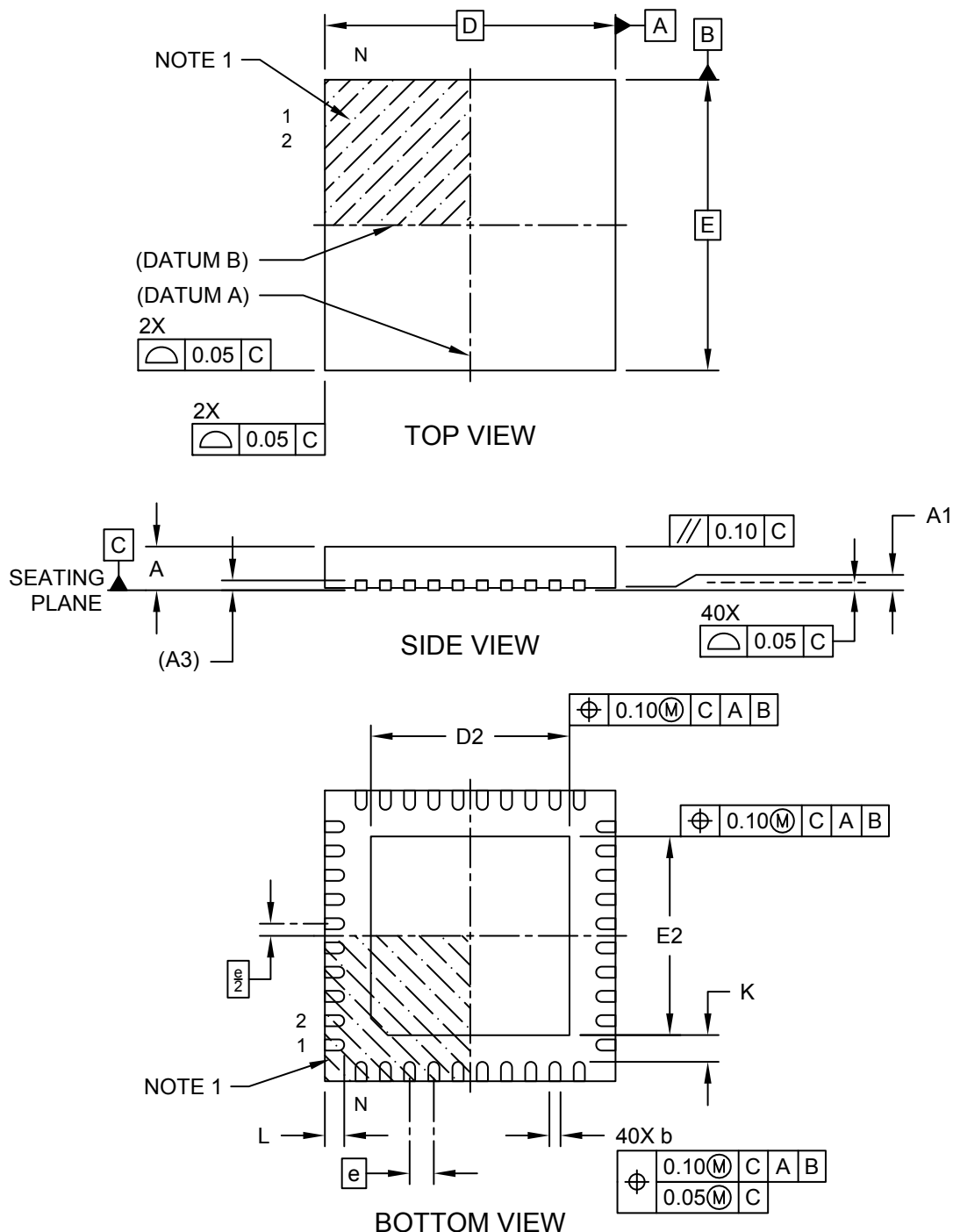

---



---

## Package Outlines and Dimensions

---



---

### 40-Lead Very Thin Plastic Quad Flat, No Lead Package (PQA) - 6x6 mm Body [VQFN] With 4.1x4.1 mm Exposed Pad

**Note:** For the most current package drawings, please see the Microchip Packaging Specification located at <http://www.microchip.com/packaging>

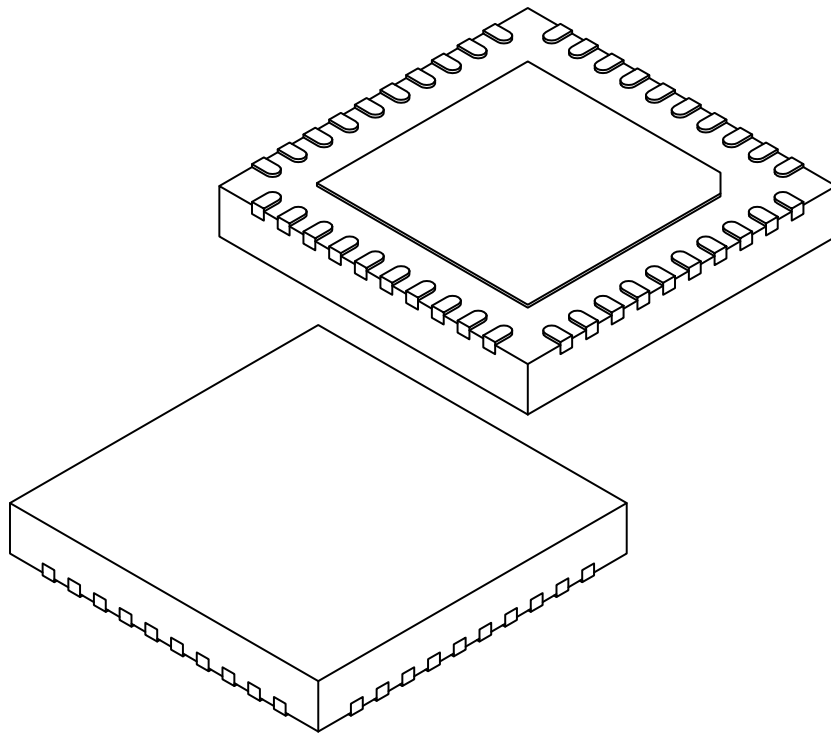

		Units	MILLIMETERS		
		Dimension Limits	MIN	NOM	MAX
Number of Terminals	N	40			
Pitch	e	0.50 BSC			
Overall Height	A	0.80	0.85	0.90	
Standoff	A1	0.00	0.02	0.05	
Terminal Thickness	A3	0.203 REF			
Overall Length	D	6.00 BSC			
Exposed Pad Length	D2	4.05	4.10	4.15	
Overall Width	E	6.00 BSC			
Exposed Pad Width	E2	4.05	4.10	4.15	
Terminal Width	b	0.18	0.23	0.28	
Terminal Length	L	0.35	0.40	0.45	
Terminal-to-Exposed-Pad	K	0.20	-	-	

**Notes:**

1. Pin 1 visual index feature may vary, but must be located within the hatched area.
2. Package is saw singulated
3. Dimensioning and tolerancing per ASME Y14.5M
  - BSC: Basic Dimension. Theoretically exact value shown without tolerances.
  - REF: Reference Dimension, usually without tolerance, for information purposes only.

**Footprint Outlines and Dimensions**

**40-Lead Very Thin Plastic Quad Flat, No Lead Package (PQA) - 6x6 mm Body [VQFN]  
With 4.1x4.1 mm Exposed Pad**

**Note:** For the most current package drawings, please see the Microchip Packaging Specification located at <http://www.microchip.com/packaging>

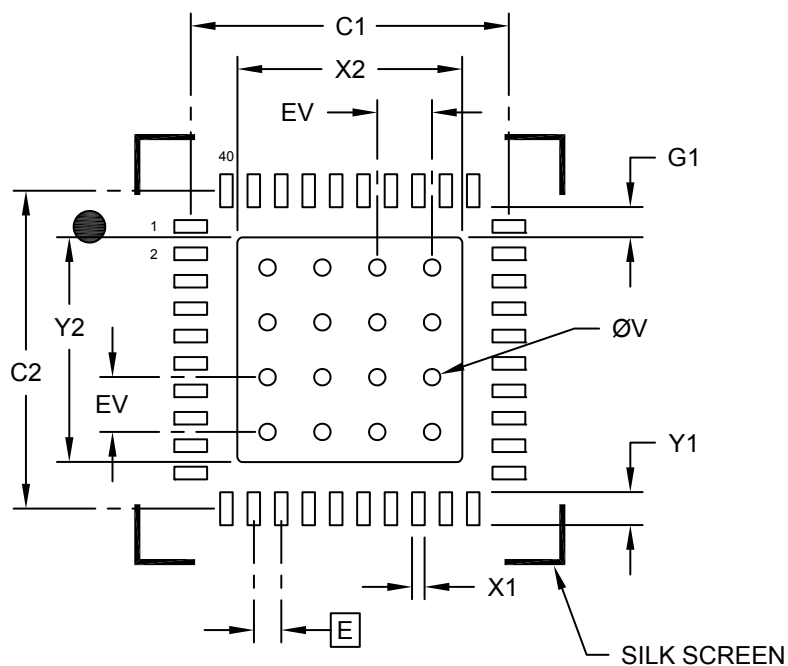

**RECOMMENDED LAND PATTERN**

Dimension Limits	Units	MILLIMETERS		
		MIN	NOM	MAX
Contact Pitch	E	0.50 BSC		
Center Pad Width	X2			4.10
Center Pad Length	Y2			4.10
Contact Pad Spacing	C1		5.80	
Contact Pad Spacing	C2		5.80	
Contact Pad Width (X40)	X1			0.23
Contact Pad Length (X40)	Y1			0.60
Contact Pad to Center Pad (X20)	G1	0.20		
Thermal Via Diameter	V		0.30	
Thermal Via Pitch	EV		1.00	

**Notes:**

1. Dimensioning and tolerancing per ASME Y14.5M  
BSC: Basic Dimension. Theoretically exact value shown without tolerances.
2. For best soldering results, thermal vias should be filled or tented to avoid solder loss during reflow process



**Package Outlines and Dimensions**

**44-Lead Very Thin Plastic Quad Flat, No Lead Package (PGA) - 7x7x0.9 mm Body [VQFN] With 5.1x5.1 mm Exposed Pad**

**Note:** For the most current package drawings, please see the Microchip Packaging Specification located at <http://www.microchip.com/packaging>

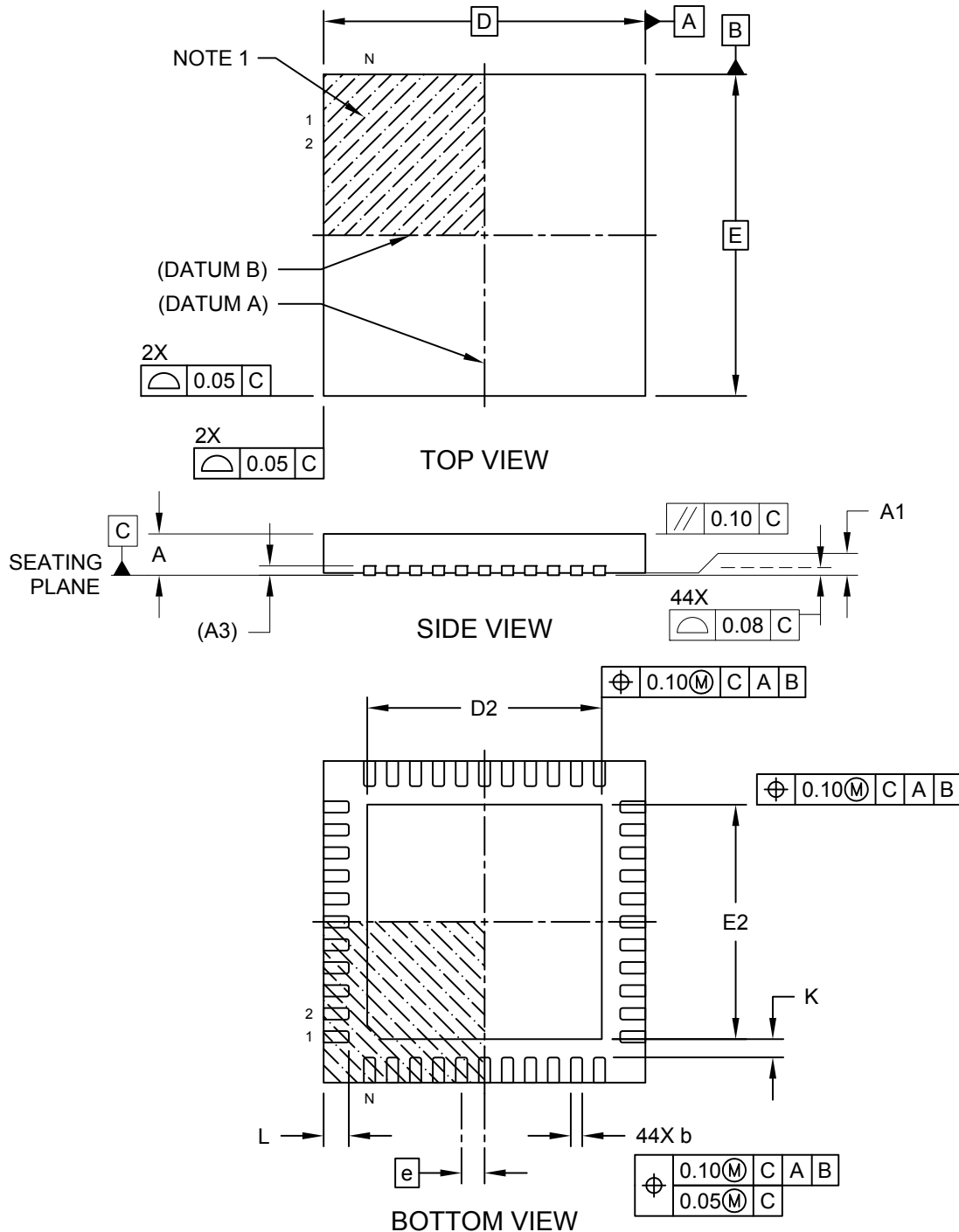

Microchip Technology Drawing C04-1213A Sheet 1 of 2

**Package Outlines and Dimensions**

**44-Lead Very Thin Plastic Quad Flat, No Lead Package (PGA) - 7x7x0.9 mm Body [VQFN]  
With 5.1x5.1 mm Exposed Pad**

**Note:** For the most current package drawings, please see the Microchip Packaging Specification located at <http://www.microchip.com/packaging>

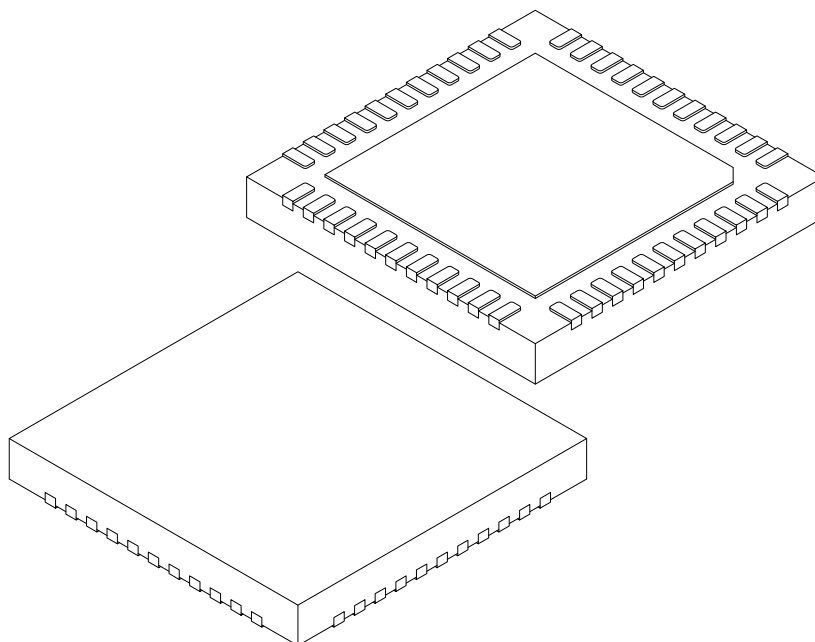

		Units	MILLIMETERS		
Dimension Limits			MIN	NOM	MAX
Number of Terminals	N		44		
Pitch	e		0.50 BSC		
Overall Height	A	0.80	0.85	0.90	
Standoff	A1	0.00	0.02	0.05	
Terminal Thickness	A3	0.203 REF			
Overall Length	D	7.00 BSC			
Exposed Pad Length	D2	5.05	5.10	5.15	
Overall Width	E	7.00 BSC			
Exposed Pad Width	E2	5.05	5.10	5.15	
Terminal Width	b	0.20	0.25	0.30	
Terminal Length	L	0.50	0.55	0.60	
Terminal-to-Exposed-Pad	K	0.20	-	-	

**Notes:**

- Pin 1 visual index feature may vary, but must be located within the hatched area.
- Package is saw singulated
- Dimensioning and tolerancing per ASME Y14.5M

BSC: Basic Dimension. Theoretically exact value shown without tolerances.

REF: Reference Dimension, usually without tolerance, for information purposes only.

---



---

## Footprint Outlines and Dimensions

---



---

### 44-Lead Very Thin Plastic Quad Flat, No Lead Package (PGA) - 7x7x0.9 mm Body [VQFN] With 5.1x5.1 mm Exposed Pad

**Note:** For the most current package drawings, please see the Microchip Packaging Specification located at <http://www.microchip.com/packaging>

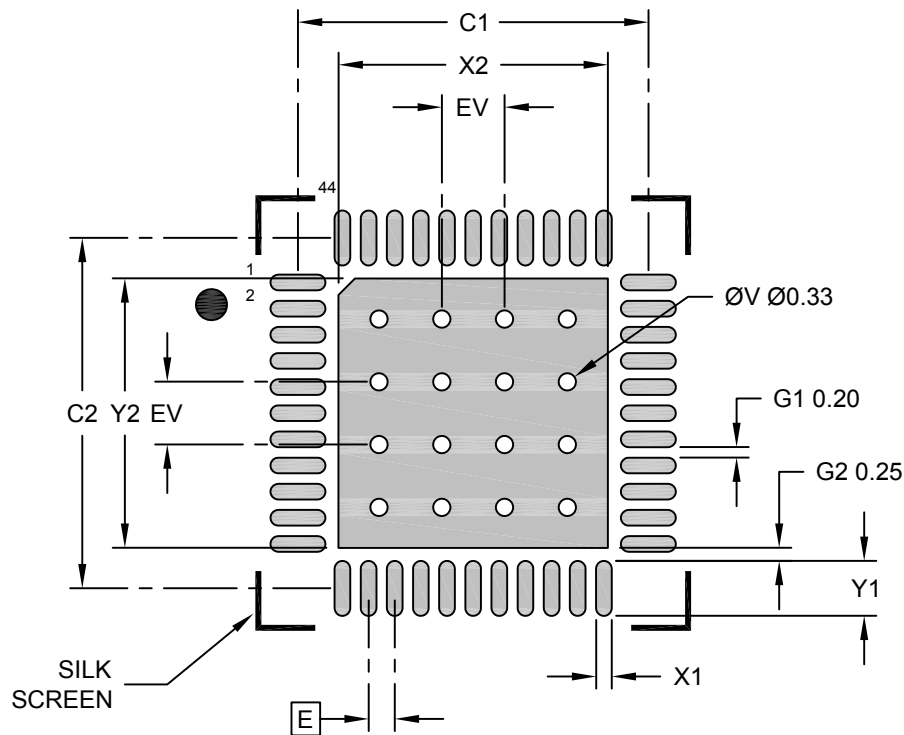

### RECOMMENDED LAND PATTERN

Units		MILLIMETERS		
Dimension Limits		MIN	NOM	MAX
Contact Pitch	E	0.50 BSC		
Optional Center Pad Width	X2			5.15
Optional Center Pad Length	Y2			5.15
Contact Pad Spacing	C1		6.70	
Contact Pad Spacing	C2		6.70	
Contact Pad Width (X44)	X1			0.30
Contact Pad Length (X44)	Y1			1.05
Contact Pad to Contact Pad (X40)	G1	0.20		
Contact Pad to Center Pad (X44)	G2	0.25		
Thermal Via Diameter	V		0.33	
Thermal Via Pitch	EV		1.20	

**Notes:**

1. Dimensioning and tolerancing per ASME Y14.5M  
BSC: Basic Dimension. Theoretically exact value shown without tolerances.
2. For best soldering results, thermal vias, if used, should be filled or tented to avoid solder loss during reflow process

Microchip Technology Drawing C04-3213A

**Package Outlines and Dimensions**

**44-Lead Very Thin Plastic Quad Flat, No Lead Package (3N) - 8x8x1.0 mm Body [VQFN] With Wettable Flanks (Stepped)**

**Note:** For the most current package drawings, please see the Microchip Packaging Specification located at <http://www.microchip.com/packaging>

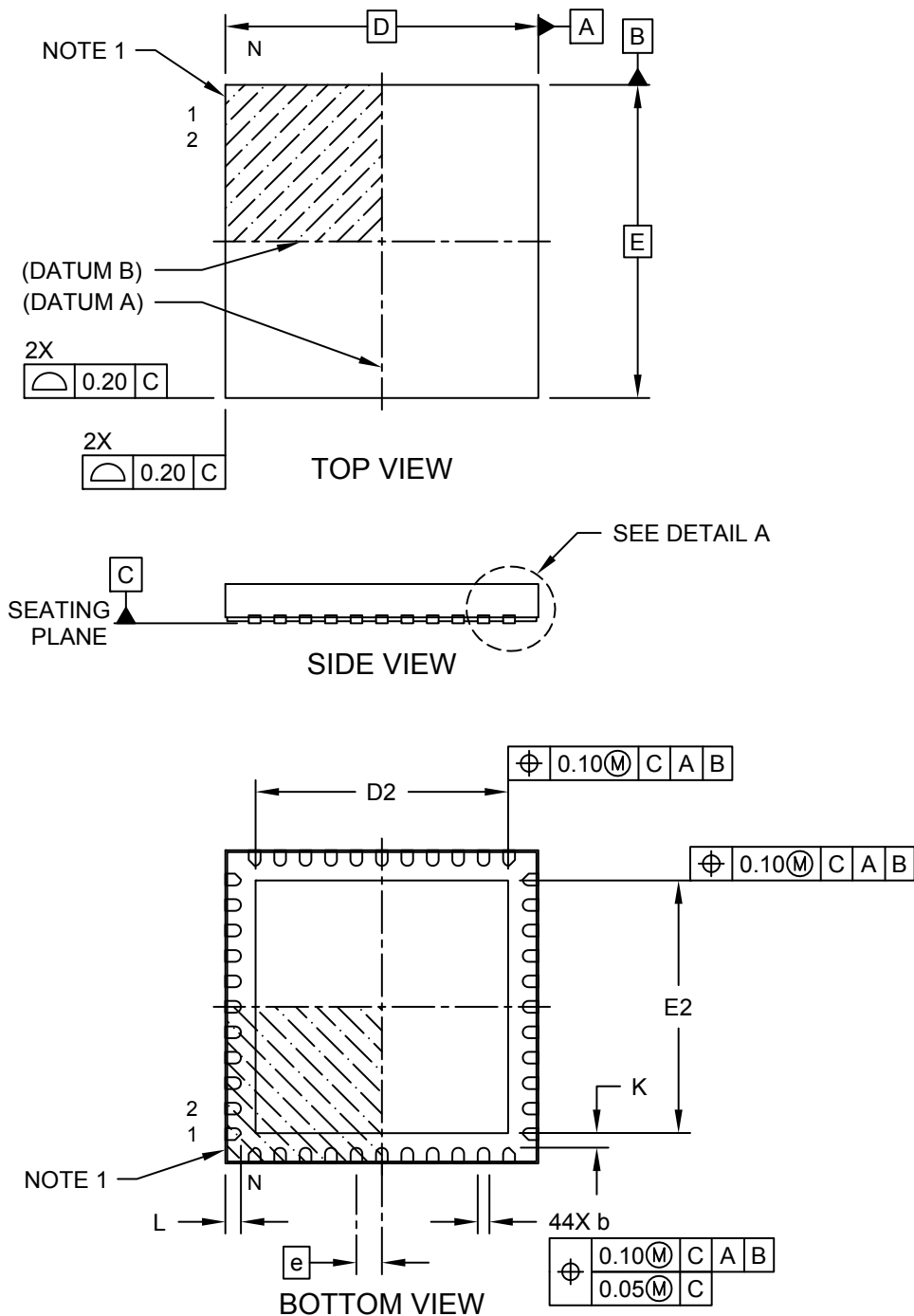

---



---

## Package Outlines and Dimensions

---



---

### 44-Lead Very Thin Plastic Quad Flat, No Lead Package (3N) - 8x8x1.0 mm Body [VQFN] With Wettable Flanks (Stepped)

**Note:** For the most current package drawings, please see the Microchip Packaging Specification located at <http://www.microchip.com/packaging>

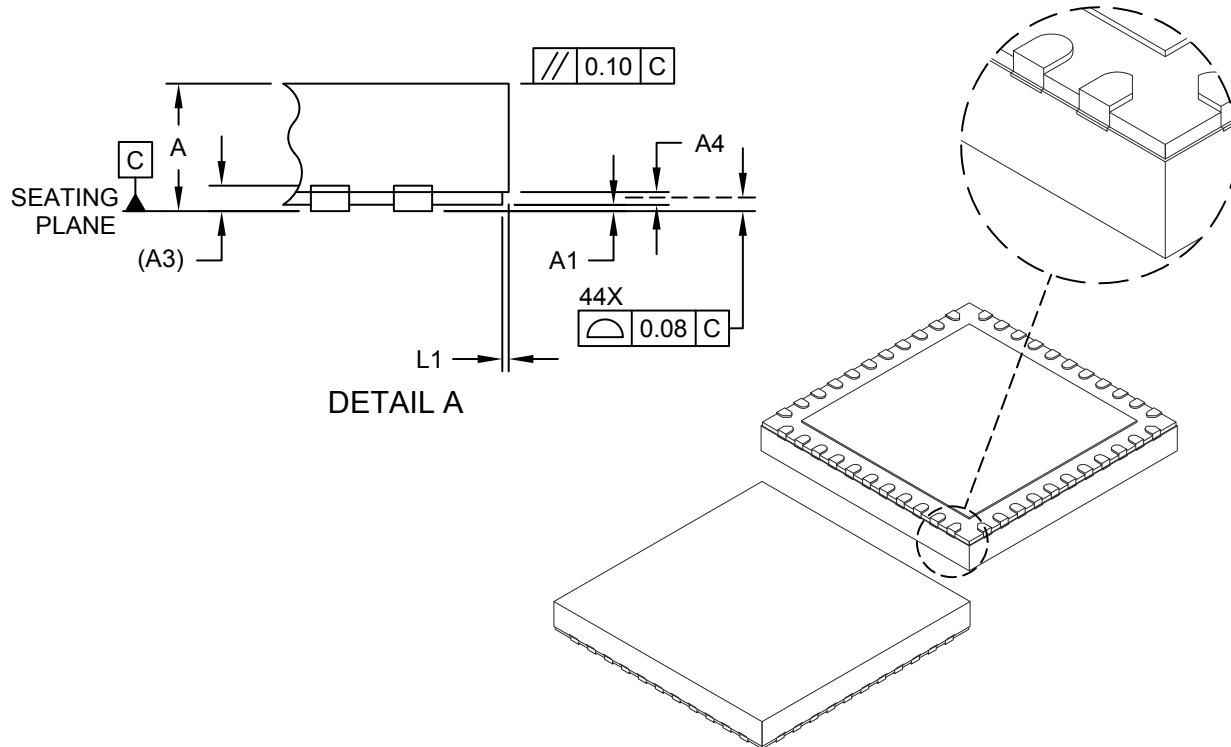

		MILLIMETERS		
Units				
Dimension Limits		MIN	NOM	MAX
Number of Terminals	N	44		
Pitch	e	0.65 BSC		
Overall Height	A	0.80	0.90	1.00
Standoff	A1	0.00	0.02	0.05
Terminal Thickness	A3	0.20 REF		
Step Height	A4	0.05	0.12	0.19
Overall Length	D	8.00 BSC		
Exposed Pad Length	D2	6.25	6.45	6.60
Overall Width	E	8.00 BSC		
Exposed Pad Width	E2	6.25	6.45	6.60
Terminal Width	b	0.20	0.30	0.35
Terminal Length	L	0.30	0.40	0.50
Step Length	L1	0.035	0.060	0.085
Terminal-to-Exposed-Pad	K	0.20	-	-

**Notes:**

1. Pin 1 visual index feature may vary, but must be located within the hatched area.
2. Package is saw singulated
3. Dimensioning and tolerancing per ASME Y14.5M
  - BSC: Basic Dimension. Theoretically exact value shown without tolerances.
  - REF: Reference Dimension, usually without tolerance, for information purposes only.

**Package Outlines and Dimensions**

**44-Lead Very Thin Plastic Quad Flat, No Lead Package (3N) - 8x8x1.0 mm Body [VQFN] With Wettable Flanks (Stepped)**

**Note:** For the most current package drawings, please see the Microchip Packaging Specification located at <http://www.microchip.com/packaging>

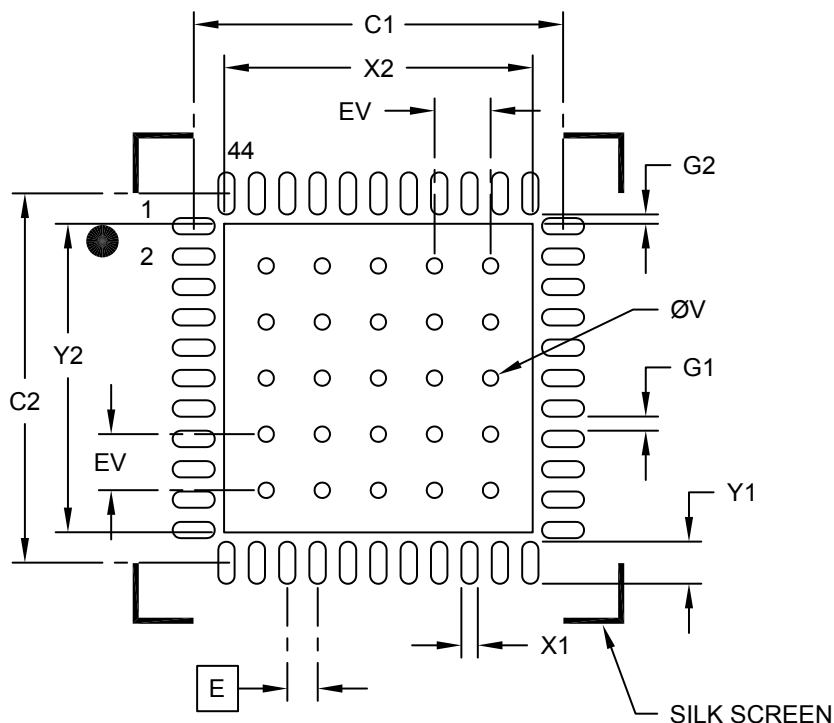

**RECOMMENDED LAND PATTERN**

Dimension Limits	Units	MILLIMETERS		
		MIN	NOM	MAX
Contact Pitch	E	0.65 BSC		
Optional Center Pad Width	X2			6.60
Optional Center Pad Length	Y2			6.60
Contact Pad Spacing	C1		7.90	
Contact Pad Spacing	C2		7.90	
Contact Pad Width (X44)	X1			0.35
Contact Pad Length (X44)	Y1			0.90
Contact Pad to Pad (X40)	G1	0.30		
Contact Pad to Center Pad (X44)	G2	0.20		
Thermal Via Diameter	V		0.33	
Thermal Via Pitch	EV		1.20	

**Notes:**

1. Dimensioning and tolerancing per ASME Y14.5M  
BSC: Basic Dimension. Theoretically exact value shown without tolerances.
2. For best soldering results, thermal vias, if used, should be filled or tented to avoid solder loss during reflow process

**Package Outlines and Dimensions**

**44-Lead Plastic Quad Flat, No Lead Package (ML) - 8x8 mm Body [QFN or VQFN]**

**Note:** For the most current package drawings, please see the Microchip Packaging Specification located at <http://www.microchip.com/packaging>

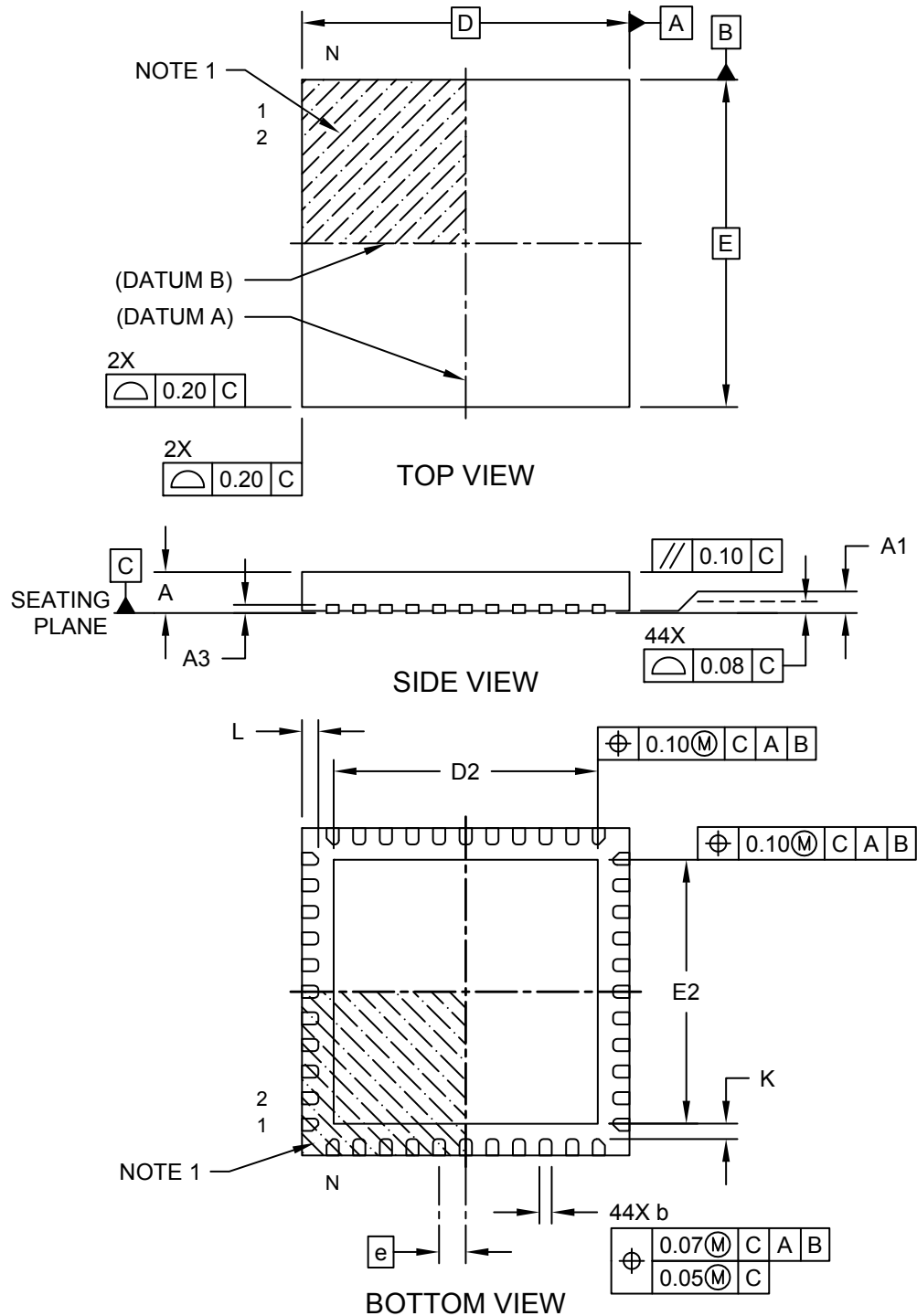

**Package Outlines and Dimensions**

**44-Lead Plastic Quad Flat, No Lead Package (ML) - 8x8 mm Body [QFN or VQFN]**

**Note:** For the most current package drawings, please see the Microchip Packaging Specification located at <http://www.microchip.com/packaging>

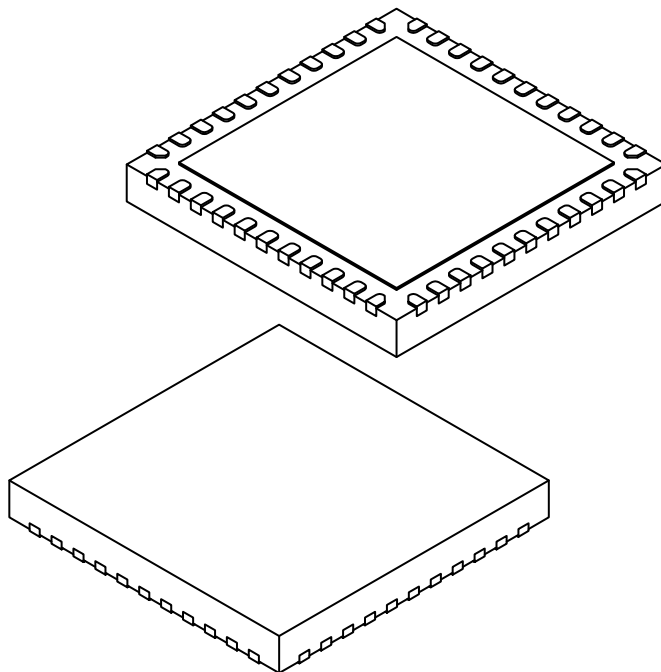

		Units	MILLIMETERS		
Dimension Limits			MIN	NOM	MAX
Number of Pins	N		44		
Pitch	e		0.65 BSC		
Overall Height	A	0.80	0.90	1.00	
Standoff	A1	0.00	0.02	0.05	
Terminal Thickness	A3	0.20 REF			
Overall Width	E	8.00 BSC			
Exposed Pad Width	E2	6.25	6.45	6.60	
Overall Length	D	8.00 BSC			
Exposed Pad Length	D2	6.25	6.45	6.60	
Terminal Width	b	0.20	0.30	0.35	
Terminal Length	L	0.30	0.40	0.50	
Terminal-to-Exposed-Pad	K	0.20	-	-	

Notes:

1. Pin 1 visual index feature may vary, but must be located within the hatched area.
2. Package is saw singulated
3. Dimensioning and tolerancing per ASME Y14.5M

BSC: Basic Dimension. Theoretically exact value shown without tolerances.

REF: Reference Dimension, usually without tolerance, for information purposes only.



---



---

## Footprint Outlines and Dimensions

---



---

### 44-Lead Plastic Quad Flat, No Lead Package (ML) - 8x8 mm Body [QFN or VQFN]

**Note:** For the most current package drawings, please see the Microchip Packaging Specification located at <http://www.microchip.com/packaging>

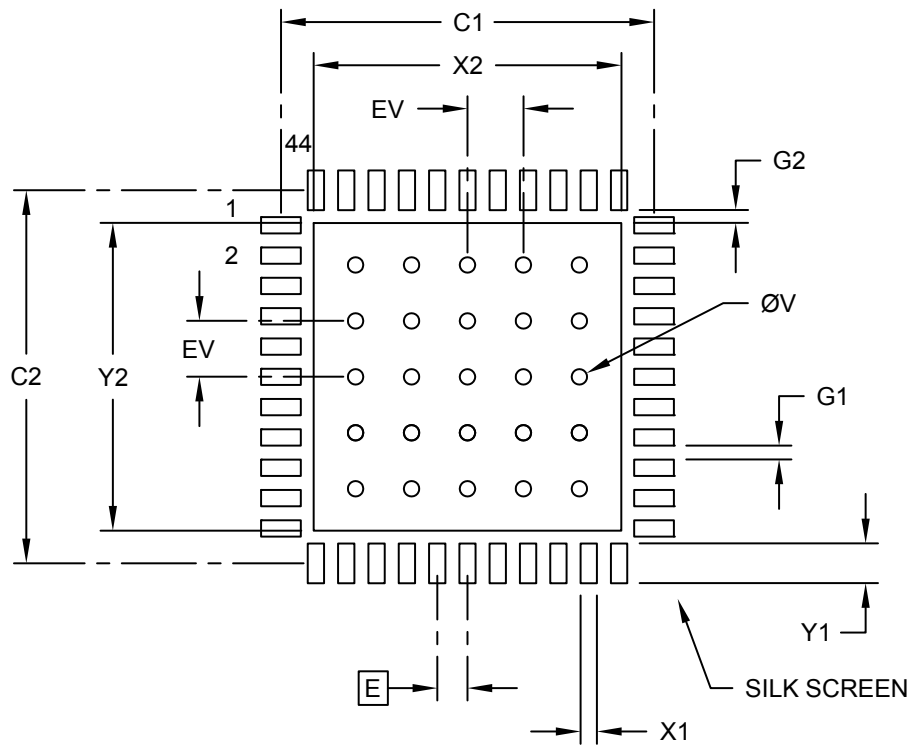

### RECOMMENDED LAND PATTERN

	Units	MILLIMETERS		
		MIN	NOM	MAX
Dimension Limits				
Contact Pitch	E	0.65 BSC		
Optional Center Pad Width	X2			6.60
Optional Center Pad Length	Y2			6.60
Contact Pad Spacing	C1		8.00	
Contact Pad Spacing	C2		8.00	
Contact Pad Width (X44)	X1			0.35
Contact Pad Length (X44)	Y1			0.85
Contact Pad to Contact Pad (X40)	G1	0.30		
Contact Pad to Center Pad (X44)	G2	0.28		
Thermal Via Diameter	V		0.33	
Thermal Via Pitch	EV		1.20	

**Notes:**

1. Dimensioning and tolerancing per ASME Y14.5M  
 BSC: Basic Dimension. Theoretically exact value shown without tolerances.
2. For best soldering results, thermal vias, if used, should be filled or tented to avoid solder loss during reflow process

**Package Outlines and Dimensions**

**48-Lead Very Thin Plastic Quad Flat, No Lead Package (UV) - 5x6.5 mm Body [VQFN]  
Saw Singulated; ISSC Legacy Package**

**Note:** For the most current package drawings, please see the Microchip Packaging Specification located at <http://www.microchip.com/packaging>

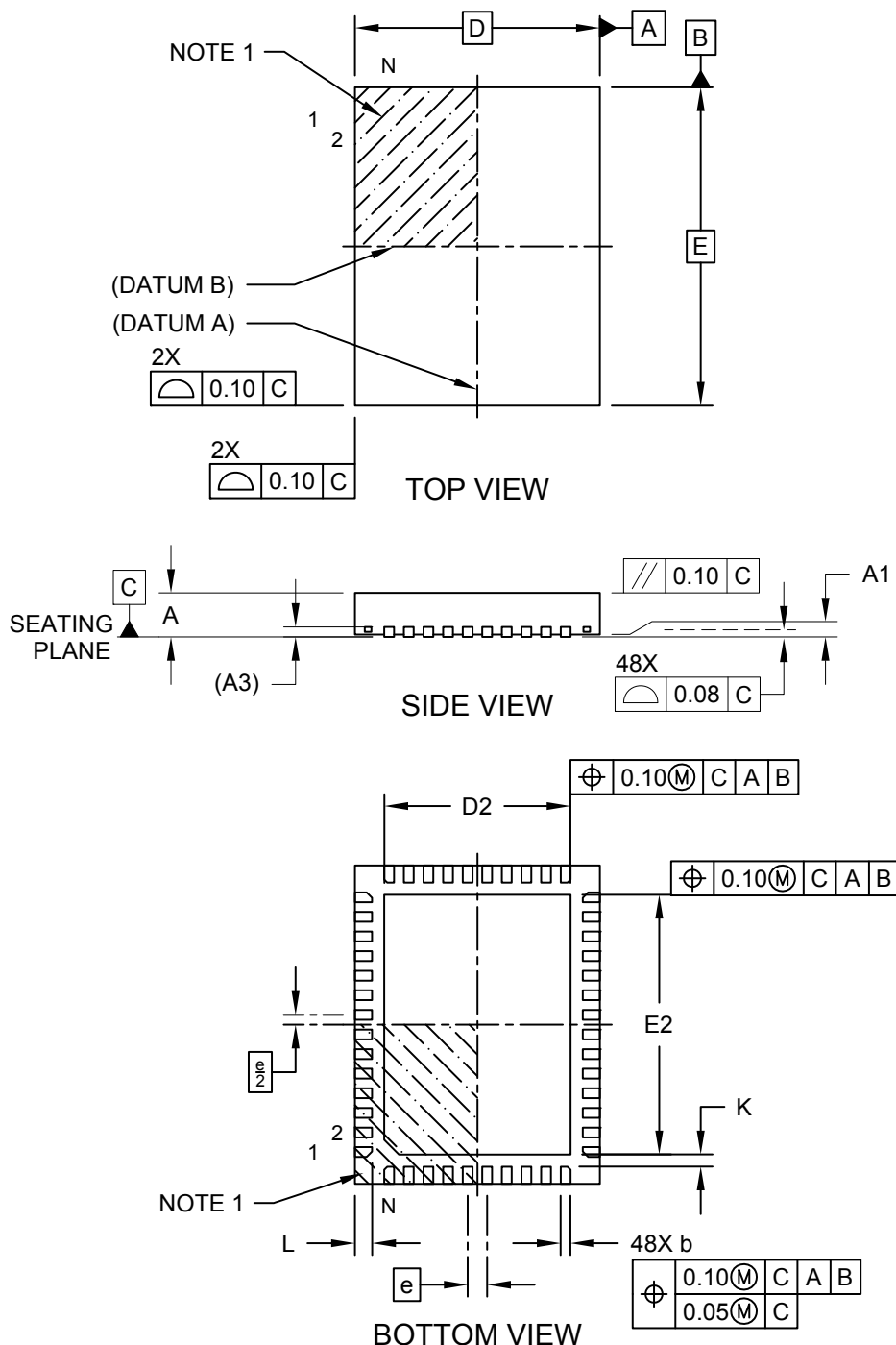

---



---

## Package Outlines and Dimensions

---



---

### 48-Lead Very Thin Plastic Quad Flat, No Lead Package (UV) - 5x6.5 mm Body [VQFN] Saw Singulated; ISSC Legacy Package

**Note:** For the most current package drawings, please see the Microchip Packaging Specification located at <http://www.microchip.com/packaging>

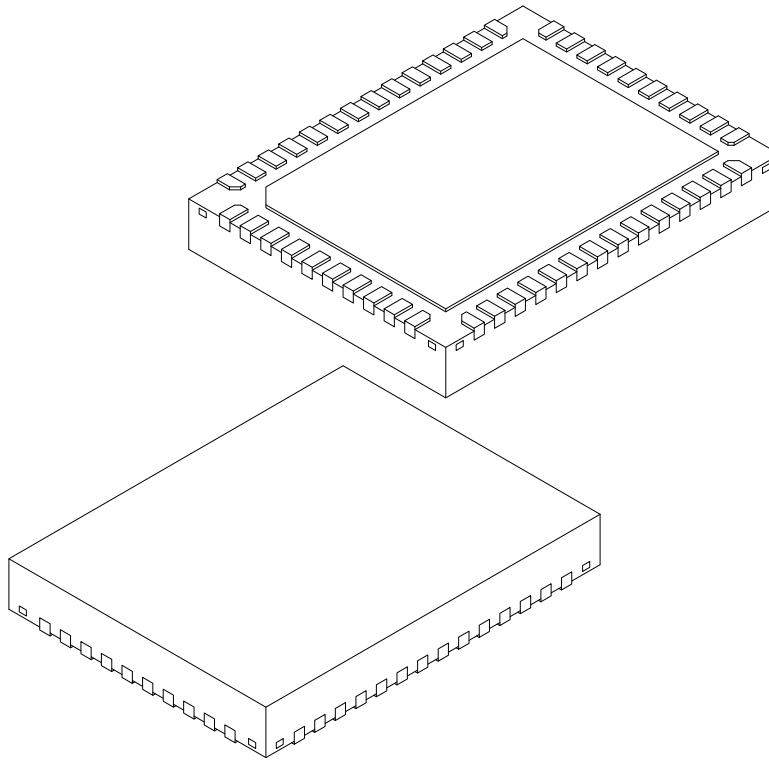

		Units	MILLIMETERS		
		Dimension Limits	MIN	NOM	MAX
Number of Terminals	N	48			
Pitch	e	0.40 BSC			
Overall Height	A	0.80	0.85	0.90	
Standoff	A1	0.00	0.02	0.05	
Terminal Thickness	A3	0.203 REF			
Overall Length	D	5.00 BSC			
Exposed Pad Length	D2	3.70	3.80	3.90	
Overall Width	E	5.00 BSC			
Exposed Pad Width	E2	5.20	5.30	5.40	
Terminal Width	b	0.15	0.20	0.25	
Terminal Length	L	0.30	0.35	0.40	
Terminal-to-Exposed-Pad	K	0.20	-	-	

**Notes:**

1. Pin 1 visual index feature may vary, but must be located within the hatched area.
2. Package is saw singulated
3. Dimensioning and tolerancing per ASME Y14.5M
  - BSC: Basic Dimension. Theoretically exact value shown without tolerances.
  - REF: Reference Dimension, usually without tolerance, for information purposes only.

**Footprint Outlines and Dimensions**

**48-Lead Very Thin Plastic Quad Flat, No Lead Package (UV) - 5x6.5 mm Body [VQFN] Saw Singulated; ISSC Legacy Package**

**Note:** For the most current package drawings, please see the Microchip Packaging Specification located at <http://www.microchip.com/packaging>

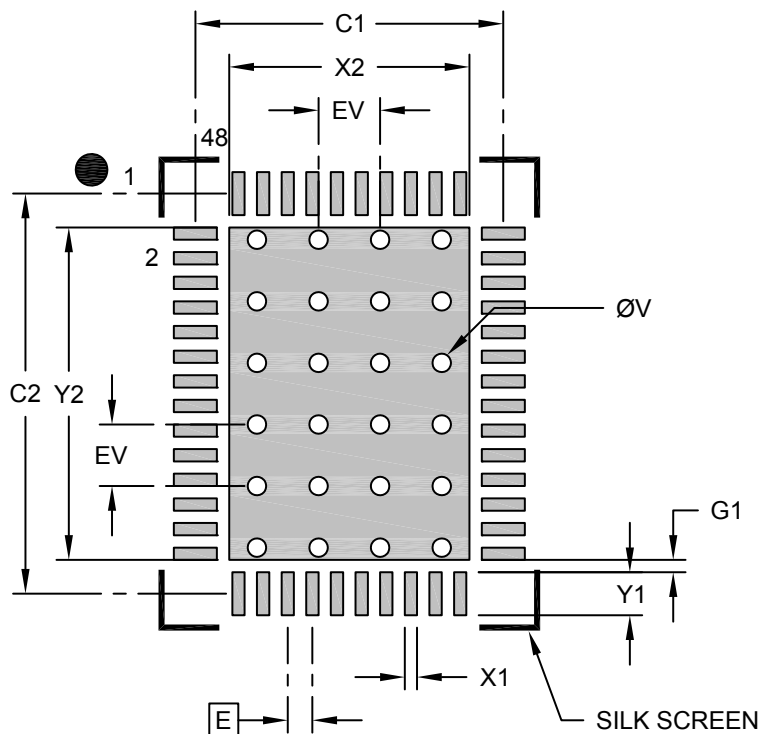

**RECOMMENDED LAND PATTERN**

Dimension Limits	Units	MILLIMETERS		
		MIN	NOM	MAX
Contact Pitch	E	0.40 BSC		
Optional Center Pad Width	X2			3.90
Optional Center Pad Length	Y2			5.40
Contact Pad Spacing	C1		5.00	
Contact Pad Spacing	C2		6.50	
Contact Pad Width (X48)	X1			0.20
Contact Pad Length (X48)	Y1			0.70
Contact Pad to Center Pad (X48)	G1	0.20		
Thermal Via Diameter	V		0.30	
Thermal Via Pitch	EV		1.00	

**Notes:**

1. Dimensioning and tolerancing per ASME Y14.5M  
BSC: Basic Dimension. Theoretically exact value shown without tolerances.
2. For best soldering results, thermal vias, if used, should be filled or tented to avoid solder loss during reflow process

**Package Outlines and Dimensions**

**48-Lead Very Thin Plastic Quad Flat, No Lead Package (VN) - 6x6 mm Body [VQFN]  
Saw Singulated; ISSC Legacy Package**

**Note:** For the most current package drawings, please see the Microchip Packaging Specification located at <http://www.microchip.com/packaging>

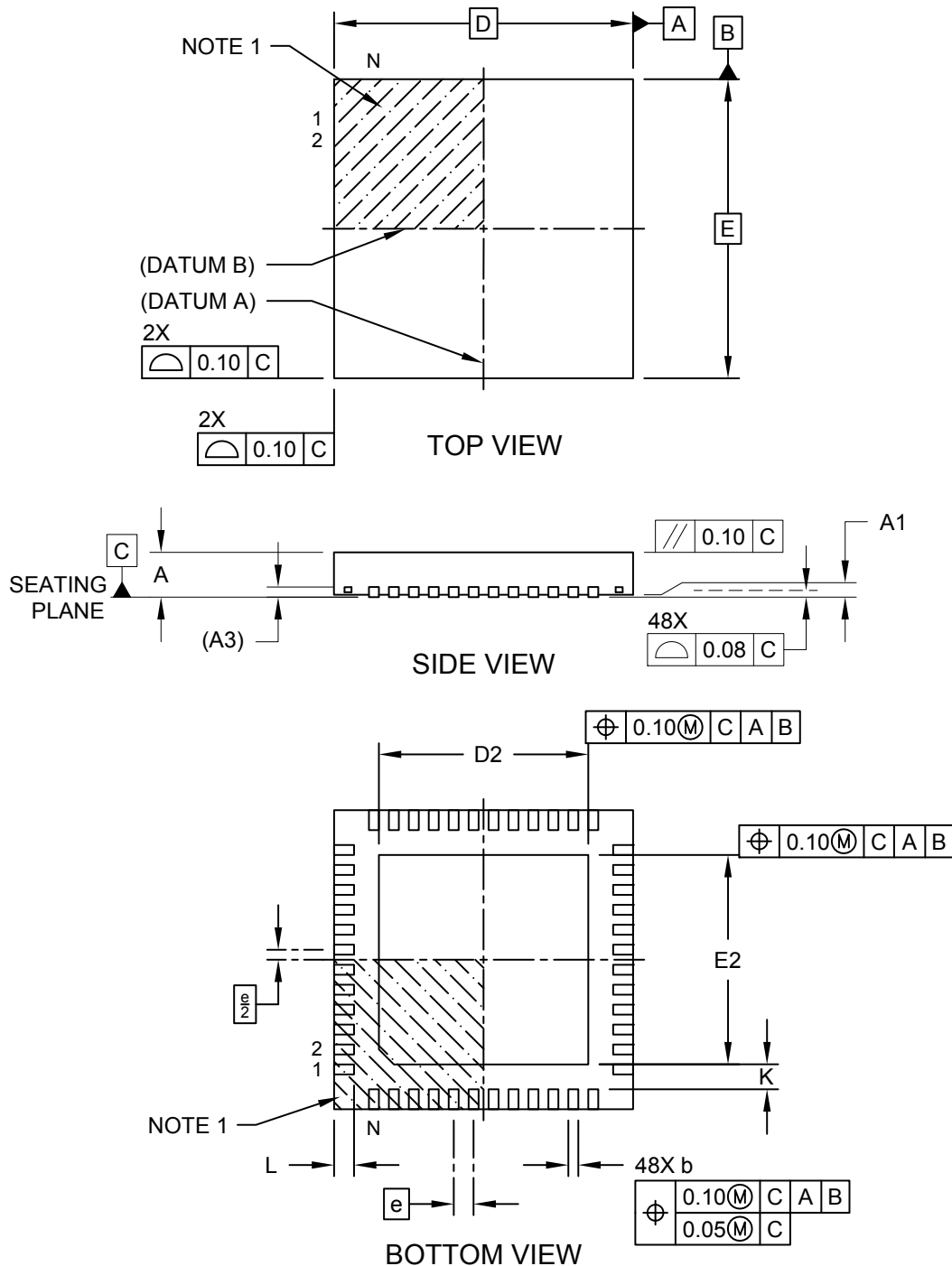

**Package Outlines and Dimensions**

**48-Lead Very Thin Plastic Quad Flat, No Lead Package (VN) - 6x6 mm Body [VQFN]  
Saw Singulated; ISSC Legacy Package**

**Note:** For the most current package drawings, please see the Microchip Packaging Specification located at <http://www.microchip.com/packaging>

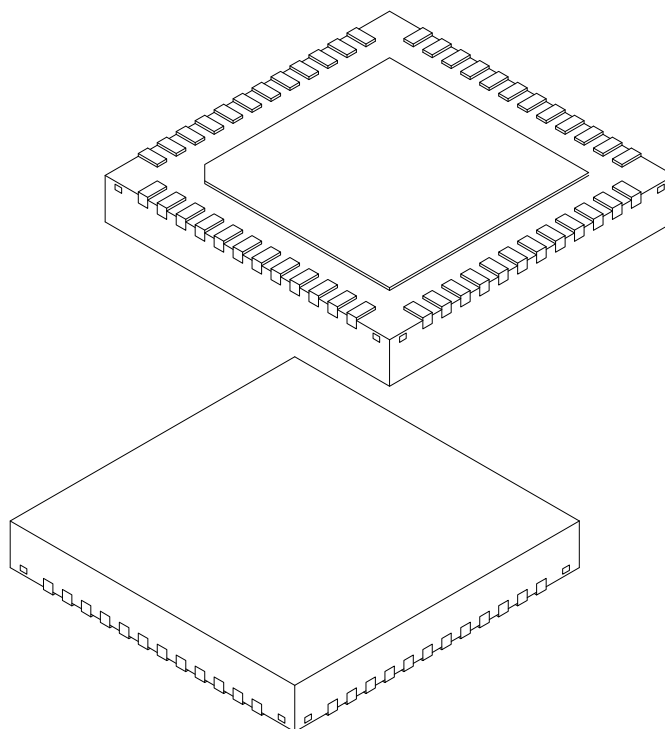

		Units	MILLIMETERS		
Dimension Limits			MIN	NOM	MAX
Number of Terminals	N		48		
Pitch	e		0.40 BSC		
Overall Height	A	0.80	0.85	0.90	
Standoff	A1	0.00	0.02	0.05	
Terminal Thickness	A3	0.203 REF			
Overall Length	D	6.00 BSC			
Exposed Pad Length	D2	4.10	4.20	4.30	
Overall Width	E	6.00 BSC			
Exposed Pad Width	E2	4.10	4.20	4.30	
Terminal Width	b	0.15	0.20	0.25	
Terminal Length	L	0.35	0.40	0.45	
Terminal-to-Exposed-Pad	K	0.20	-	-	

**Notes:**

1. Pin 1 visual index feature may vary, but must be located within the hatched area.
2. Package is saw singulated
3. Dimensioning and tolerancing per ASME Y14.5M

BSC: Basic Dimension. Theoretically exact value shown without tolerances.

REF: Reference Dimension, usually without tolerance, for information purposes only.

---



---

## Footprint Outlines and Dimensions

---



---

### 48-Lead Very Thin Plastic Quad Flat, No Lead Package (VN) - 6x6 mm Body [VQFN] Saw Singulated; ISSC Legacy Package

**Note:** For the most current package drawings, please see the Microchip Packaging Specification located at <http://www.microchip.com/packaging>

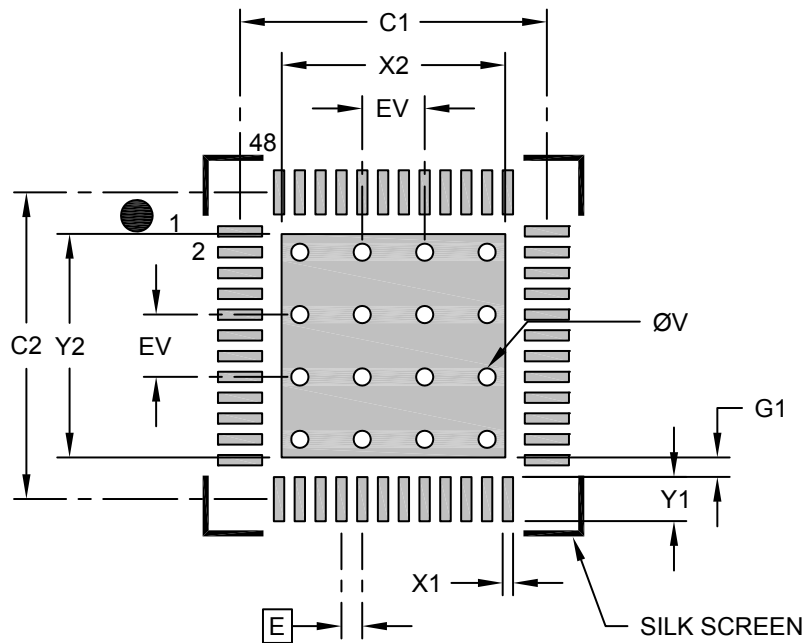

### RECOMMENDED LAND PATTERN

Dimension	Units	MILLIMETERS		
		MIN	NOM	MAX
Contact Pitch	E	0.40 BSC		
Optional Center Pad Width	X2			4.30
Optional Center Pad Length	Y2			4.30
Contact Pad Spacing	C1		5.90	
Contact Pad Spacing	C2		5.90	
Contact Pad Width (X48)	X1			0.20
Contact Pad Length (X48)	Y1			0.85
Contact Pad to Center Pad (X48)	G1	0.20		
Thermal Via Diameter	V		0.33	
Thermal Via Pitch	EV		1.20	

**Notes:**

1. Dimensioning and tolerancing per ASME Y14.5M  
BSC: Basic Dimension. Theoretically exact value shown without tolerances.
2. For best soldering results, thermal vias, if used, should be filled or tented to avoid solder loss during reflow process

**Package Outlines and Dimensions**

**48-Lead Very Thin Plastic Quad Flat, No Lead Package (VSX) - 6x6 mm Body [VQFN] With 4.3x4.3mm Exposed Pad**

**Note:** For the most current package drawings, please see the Microchip Packaging Specification located at <http://www.microchip.com/packaging>

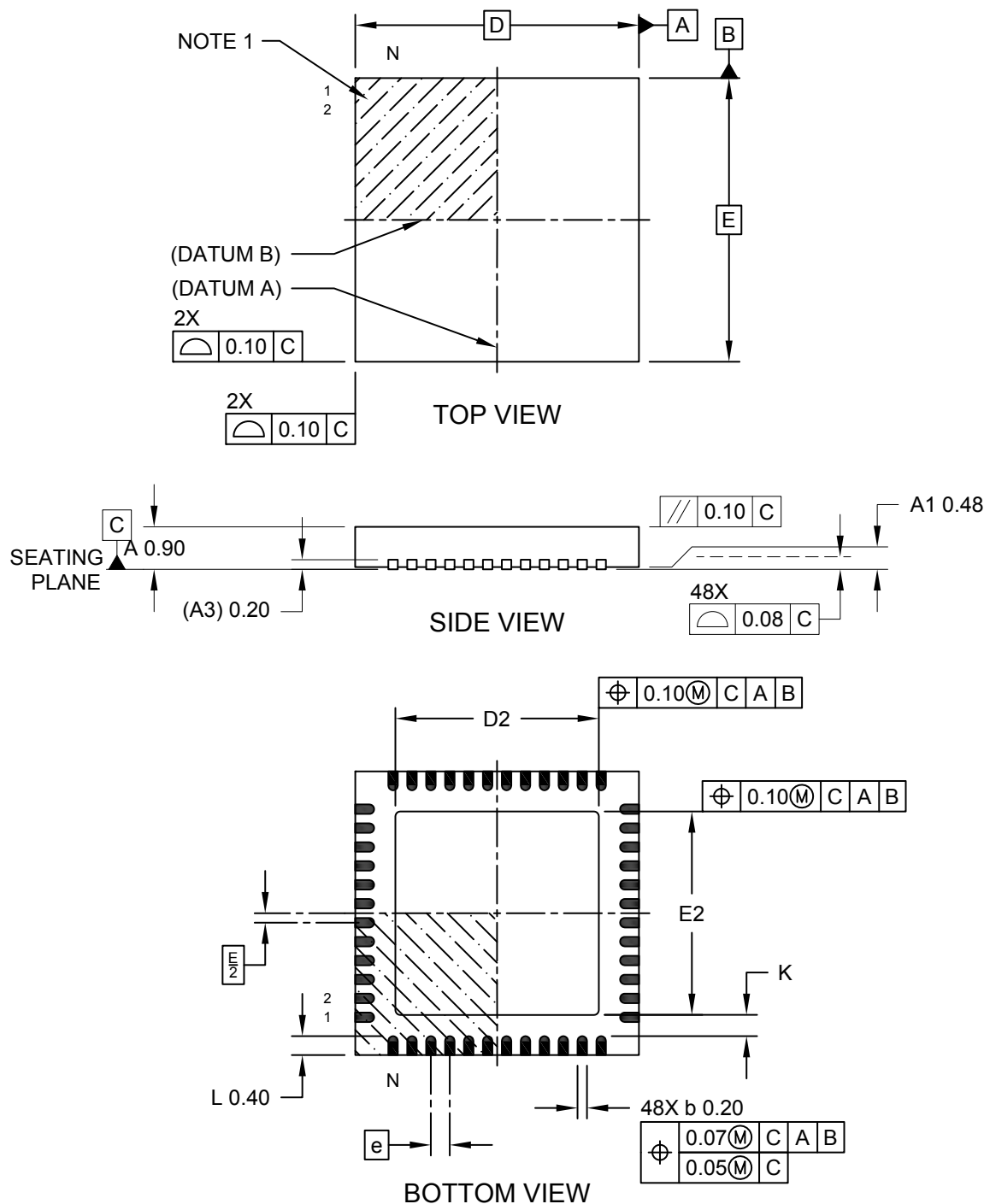



---



---

## Package Outlines and Dimensions

---



---

### 48-Lead Very Thin Plastic Quad Flat, No Lead Package (VSX) - 6x6 mm Body [VQFN] With 4.3x4.3mm Exposed Pad

**Note:** For the most current package drawings, please see the Microchip Packaging Specification located at <http://www.microchip.com/packaging>

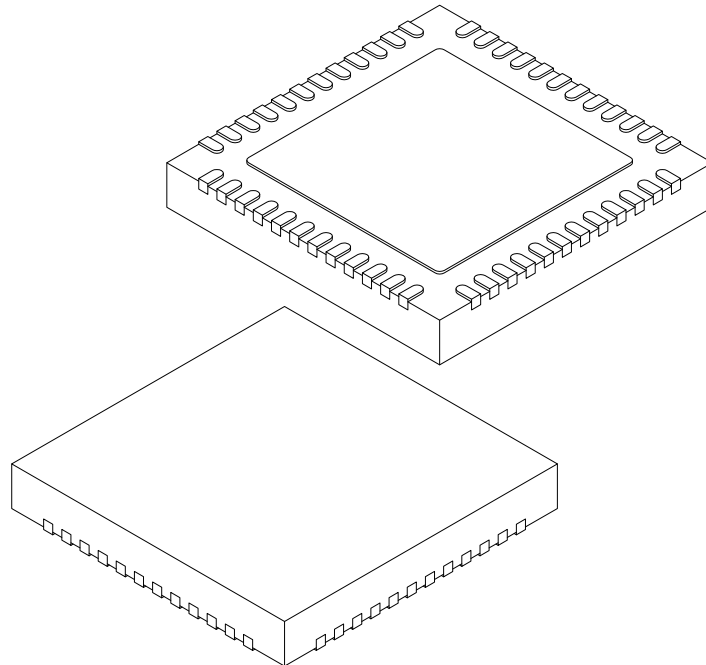

		Units	MILLIMETERS		
Dimension Limits			MIN	NOM	MAX
Number of Terminals	N		48		
Pitch	e		0.40 BSC		
Overall Height	A	0.80	0.85	0.90	
Standoff	A1	0.00	0.02	0.05	
Terminal Thickness	A3	0.203 REF			
Overall Length	D	6.00 BSC			
Exposed Pad Length	D2	4.20	4.30	4.40	
Overall Width	E	6.00 BSC			
Exposed Pad Width	E2	4.20	4.30	4.40	
Terminal Width	b	0.15	0.20	0.25	
Terminal Length	L	0.35	0.40	0.45	
Terminal-to-Exposed-Pad	K	0.35	0.45	-	

**Notes:**

1. Pin 1 visual index feature may vary, but must be located within the hatched area.
2. Package is saw singulated
3. Dimensioning and tolerancing per ASME Y14.5M

BSC: Basic Dimension. Theoretically exact value shown without tolerances.

REF: Reference Dimension, usually without tolerance, for information purposes only.

**Footprint Outlines and Dimensions**

**48-Lead Very Thin Plastic Quad Flat, No Lead Package (VSX) - 6x6 mm Body [VQFN]  
With 4.3x4.3mm Exposed Pad**

**Note:** For the most current package drawings, please see the Microchip Packaging Specification located at <http://www.microchip.com/packaging>

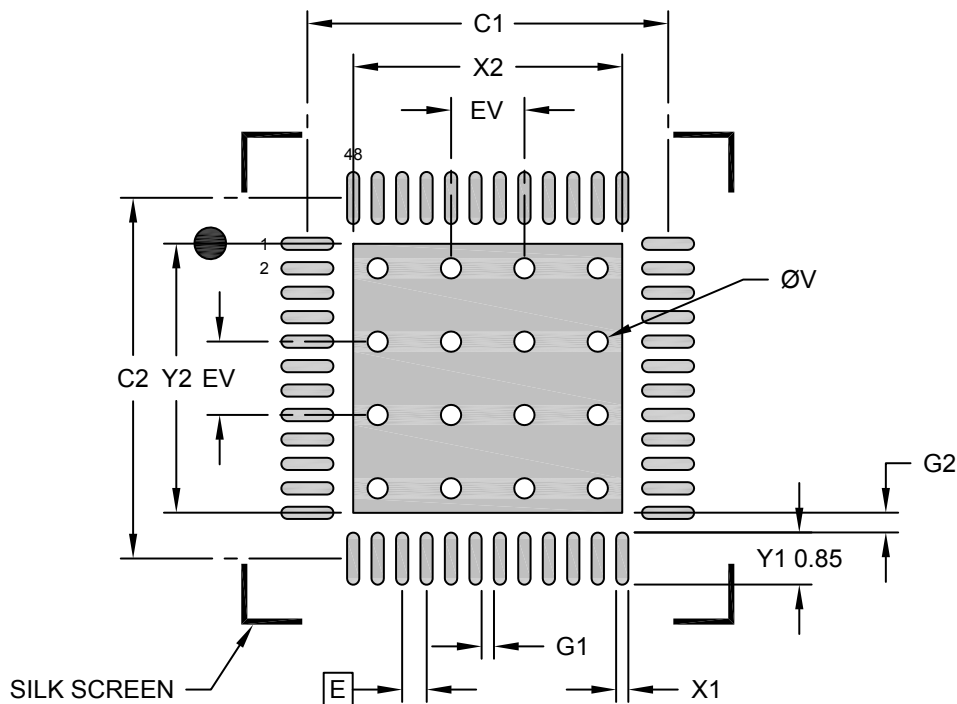

**RECOMMENDED LAND PATTERN**

Dimension Limits	Units	MILLIMETERS		
		MIN	NOM	MAX
Contact Pitch	E	0.40 BSC		
Optional Center Pad Width	X2			2.80
Optional Center Pad Length	Y2			2.80
Contact Pad Spacing	C1	4.40		
Contact Pad Spacing	C2	4.40		
Contact Pad Width (X48)	X1			0.20
Contact Pad Length (X48)	Y1			0.85
Contact Pad to Contact Pad (X44)	G1	0.20		
Contact Pad to Center Pad (X48)	G2	0.33		
Thermal Via Diameter	V		0.33	
Thermal Via Pitch	EV		1.20	

**Notes:**

1. Dimensioning and tolerancing per ASME Y14.5M  
BSC: Basic Dimension. Theoretically exact value shown without tolerances.
2. For best soldering results, thermal vias, if used, should be filled or tented to avoid solder loss during reflow process

**Package Outlines and Dimensions**

**48-Lead Very Thin Plastic Quad Flat, No Lead Package (UY) - 7x7 mm Body [VQFN]  
Saw Singulated; ISSC Legacy Package**

**Note:** For the most current package drawings, please see the Microchip Packaging Specification located at <http://www.microchip.com/packaging>

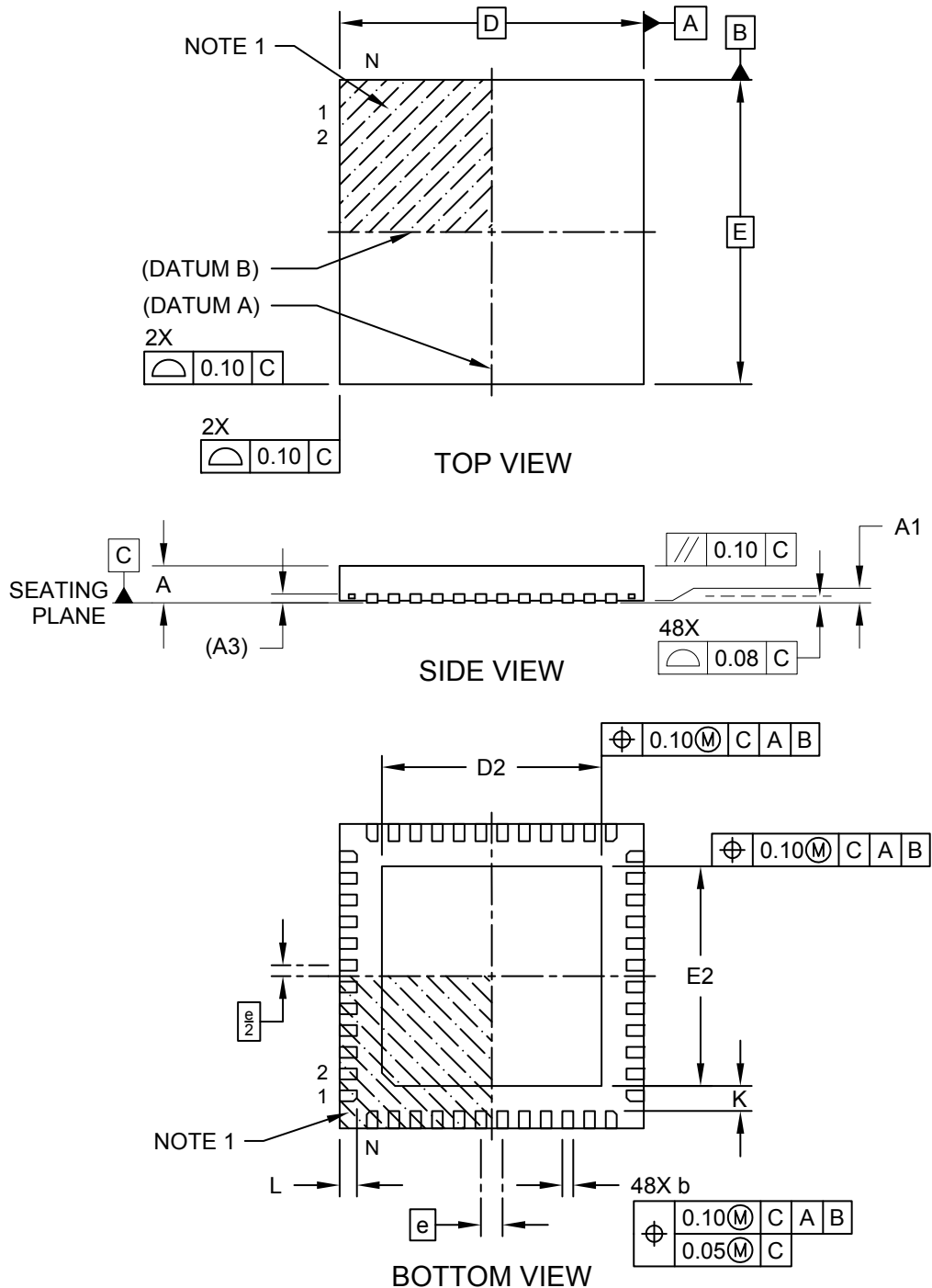

**Package Outlines and Dimensions**

**48-Lead Very Thin Plastic Quad Flat, No Lead Package (UY) - 7x7 mm Body [VQFN]  
Saw Singulated; ISSC Legacy Package**

**Note:** For the most current package drawings, please see the Microchip Packaging Specification located at <http://www.microchip.com/packaging>

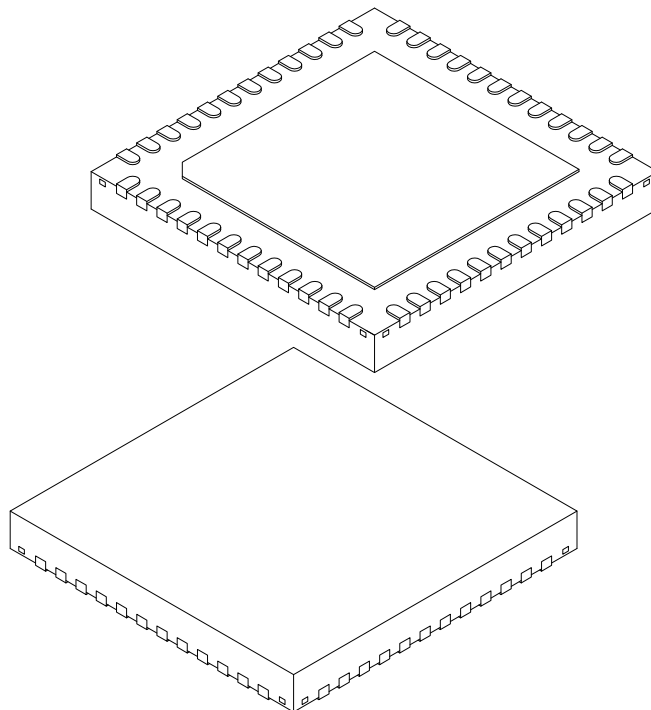

Units		MILLIMETERS		
Dimension Limits		MIN	NOM	MAX
Number of Terminals	N	48		
Pitch	e	0.50 BSC		
Overall Height	A	0.8	0.85	0.90
Standoff	A1	0.00	0.02	0.05
Terminal Thickness	A3	0.203 REF		
Overall Length	D	7.00 BSC		
Exposed Pad Length	D2	4.95	5.05	5.15
Overall Width	E	7.00 BSC		
Exposed Pad Width	E2	4.95	5.05	5.15
Terminal Width	b	0.20	0.25	0.30
Terminal Length	L	0.35	0.40	0.45
Terminal-to-Exposed-Pad	K	0.20	-	-

**Notes:**

1. Pin 1 visual index feature may vary, but must be located within the hatched area.
2. Package is saw singulated
3. Dimensioning and tolerancing per ASME Y14.5M

BSC: Basic Dimension. Theoretically exact value shown without tolerances.

REF: Reference Dimension, usually without tolerance, for information purposes only.

---



---

## Footprint Outlines and Dimensions

---



---

### 48-Lead Very Thin Plastic Quad Flat, No Lead Package (UY) - 7x7 mm Body [VQFN] Saw Singulated; ISSC Legacy Package

**Note:** For the most current package drawings, please see the Microchip Packaging Specification located at <http://www.microchip.com/packaging>

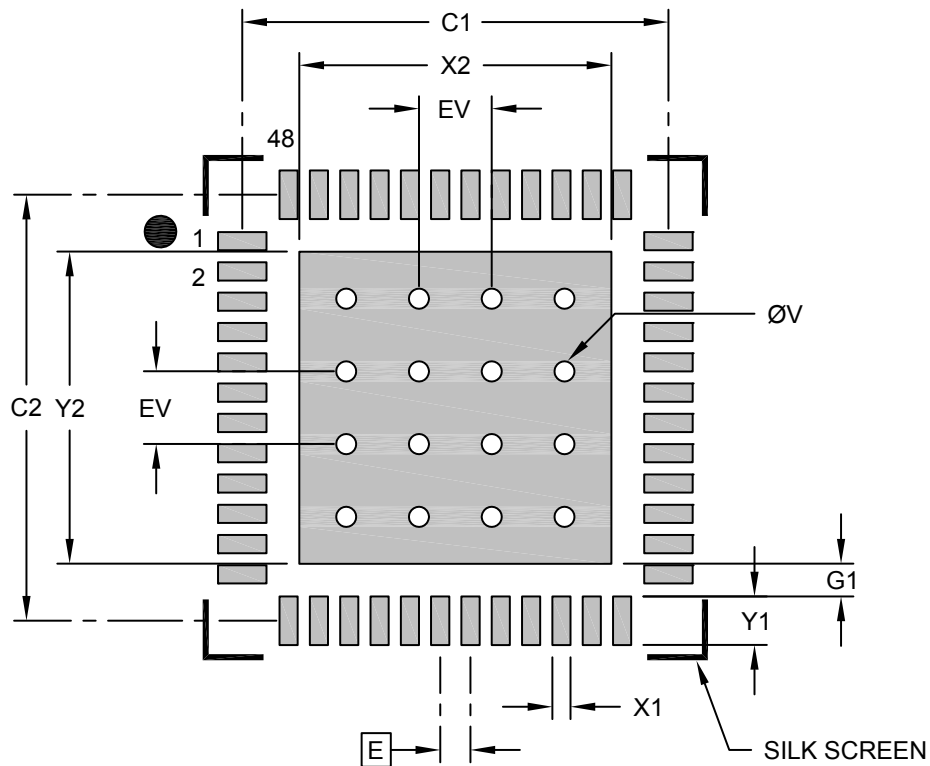

### RECOMMENDED LAND PATTERN

Dimension Limits	Units	MILLIMETERS		
		MIN	NOM	MAX
Contact Pitch	E	0.50 BSC		
Optional Center Pad Width	X2			5.15
Optional Center Pad Length	Y2			5.15
Contact Pad Spacing	C1		7.00	
Contact Pad Spacing	C2		7.00	
Contact Pad Width (X48)	X1			0.30
Contact Pad Length (X48)	Y1			0.80
Contact Pad to Center Pad (X48)	G1	0.20		
Thermal Via Diameter	V		0.33	
Thermal Via Pitch	EV		1.20	

**Notes:**

- Dimensioning and tolerancing per ASME Y14.5M  
BSC: Basic Dimension. Theoretically exact value shown without tolerances.
- For best soldering results, thermal vias, if used, should be filled or tented to avoid solder loss during reflow process

**Package Outlines and Dimensions**

**48-Lead Very Thin Plastic Quad Flat, No Lead Package (VT) - 7x7 mm Body [VQFN]  
Saw Singulated; ISSC Legacy Package**

**Note:** For the most current package drawings, please see the Microchip Packaging Specification located at <http://www.microchip.com/packaging>

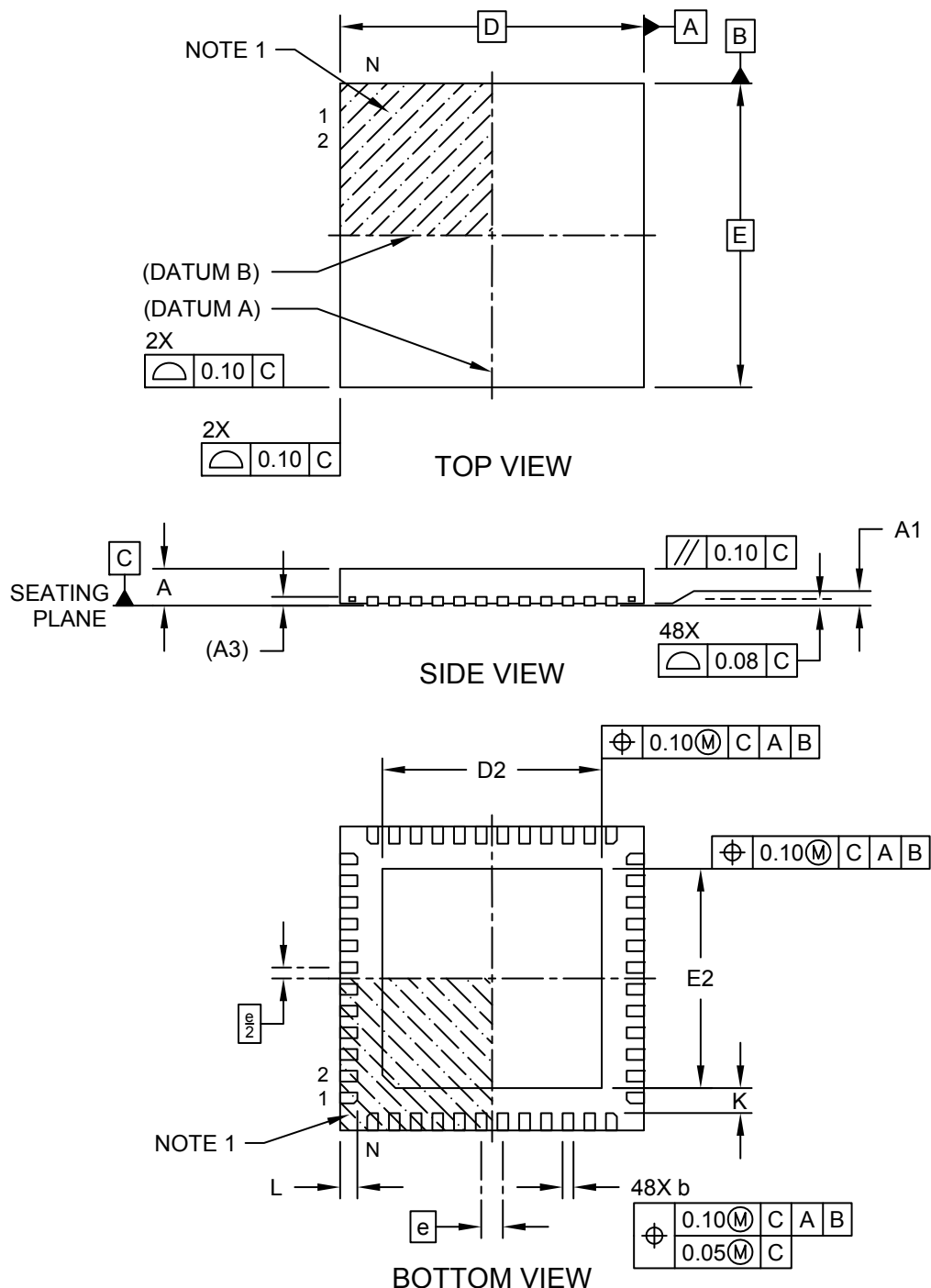

---



---

## Package Outlines and Dimensions

---



---

### 48-Lead Very Thin Plastic Quad Flat, No Lead Package (VT) - 7x7 mm Body [VQFN] Saw Singulated; ISSC Legacy Package

**Note:** For the most current package drawings, please see the Microchip Packaging Specification located at <http://www.microchip.com/packaging>

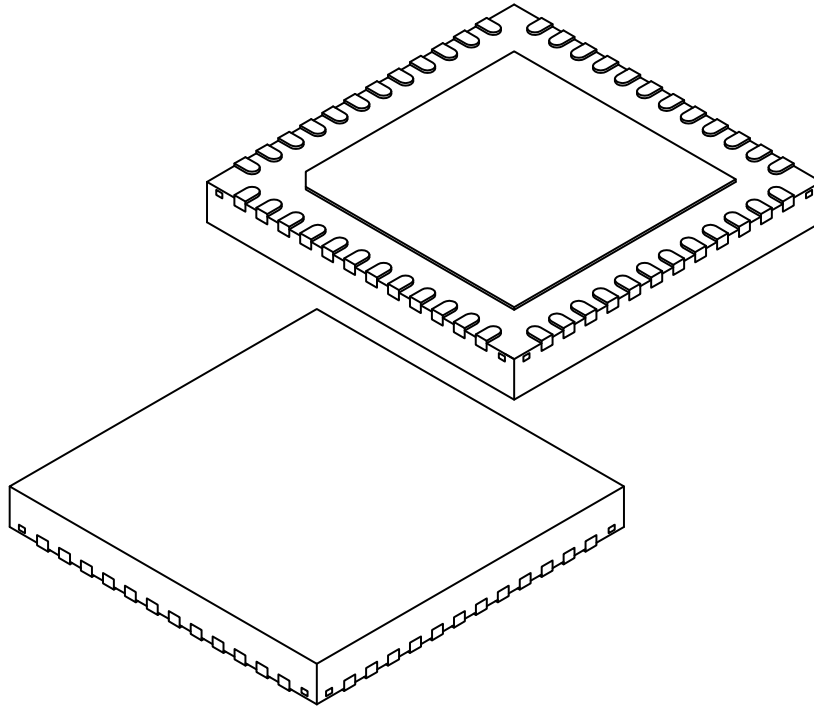

		Units	MILLIMETERS		
		Dimension Limits	MIN	NOM	MAX
Number of Terminals	N	48			
Pitch	e	0.50 BSC			
Overall Height	A	0.8	0.85	0.90	
Standoff	A1	0.00	0.02	0.05	
Terminal Thickness	A3	0.203 REF			
Overall Length	D	7.00 BSC			
Exposed Pad Length	D2	4.95	5.05	5.15	
Overall Width	E	7.00 BSC			
Exposed Pad Width	E2	4.95	5.05	5.15	
Terminal Width	b	0.20	0.25	0.30	
Terminal Length	L	0.35	0.40	0.45	
Terminal-to-Exposed-Pad	K	0.20	-	-	

**Notes:**

1. Pin 1 visual index feature may vary, but must be located within the hatched area.
2. Package is saw singulated
3. Dimensioning and tolerancing per ASME Y14.5M

BSC: Basic Dimension. Theoretically exact value shown without tolerances.

REF: Reference Dimension, usually without tolerance, for information purposes only.

**Footprint Outlines and Dimensions**

**48-Lead Very Thin Plastic Quad Flat, No Lead Package (VT) - 7x7 mm Body [VQFN]  
Saw Singulated; ISSC Legacy Package**

**Note:** For the most current package drawings, please see the Microchip Packaging Specification located at <http://www.microchip.com/packaging>

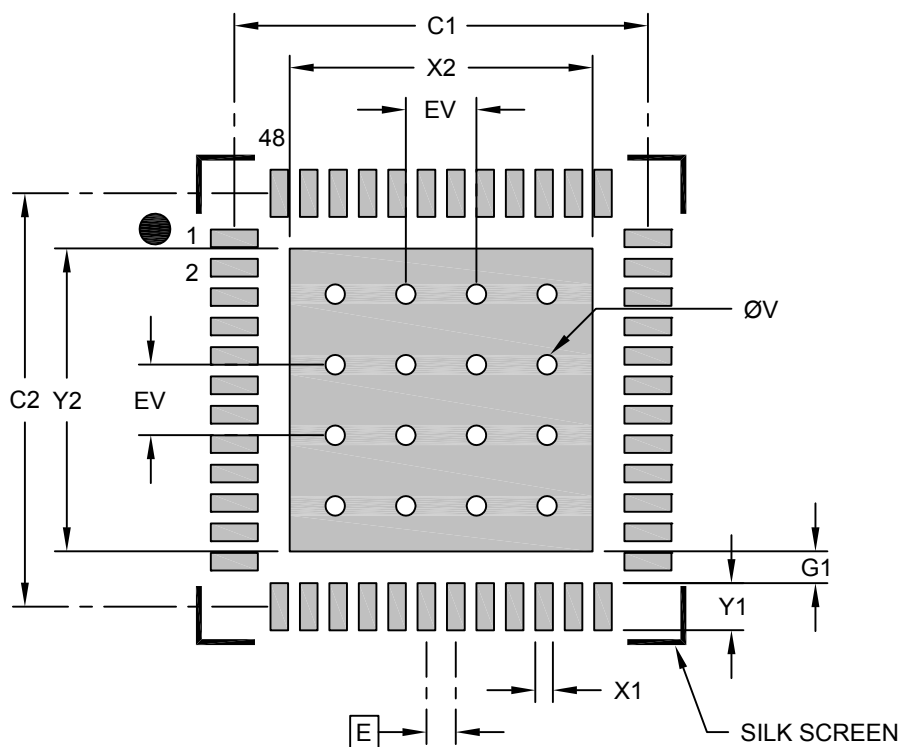

**RECOMMENDED LAND PATTERN**

Dimension Limits	Units	MILLIMETERS		
		MIN	NOM	MAX
Contact Pitch	E	0.50 BSC		
Optional Center Pad Width	X2			5.15
Optional Center Pad Length	Y2			5.15
Contact Pad Spacing	C1		7.00	
Contact Pad Spacing	C2		7.00	
Contact Pad Width (X48)	X1			0.30
Contact Pad Length (X48)	Y1			0.80
Contact Pad to Center Pad (X48)	G1	0.20		
Thermal Via Diameter	V		0.33	
Thermal Via Pitch	EV		1.20	

**Notes:**

1. Dimensioning and tolerancing per ASME Y14.5M  
BSC: Basic Dimension. Theoretically exact value shown without tolerances.
2. For best soldering results, thermal vias, if used, should be filled or tented to avoid solder loss during reflow process



**Package Outlines and Dimensions**

**48-Lead Very Thin Quad Flat, No Lead Package [ML] - 7x7x1.0 mm Body [VQFN]  
With 4.1x4.1 mm Exposed Pad**

**Note:** For the most current package drawings, please see the Microchip Packaging Specification located at <http://www.microchip.com/packaging>

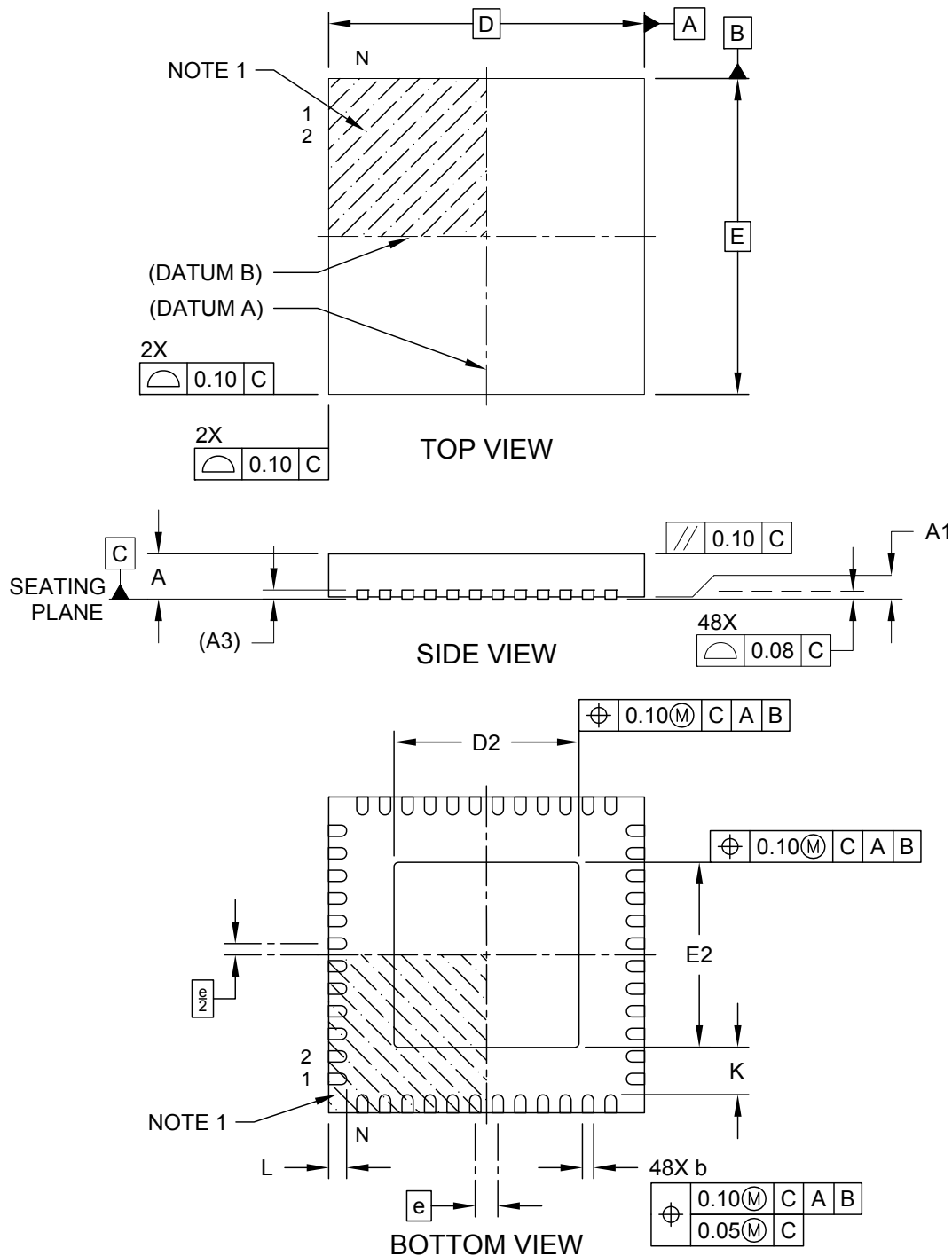

**Package Outlines and Dimensions**

**48-Lead Very Thin Quad Flat, No Lead Package [ML] - 7x7x1.0 mm Body [VQFN]  
With 4.1x4.1 mm Exposed Pad**

**Note:** For the most current package drawings, please see the Microchip Packaging Specification located at <http://www.microchip.com/packaging>

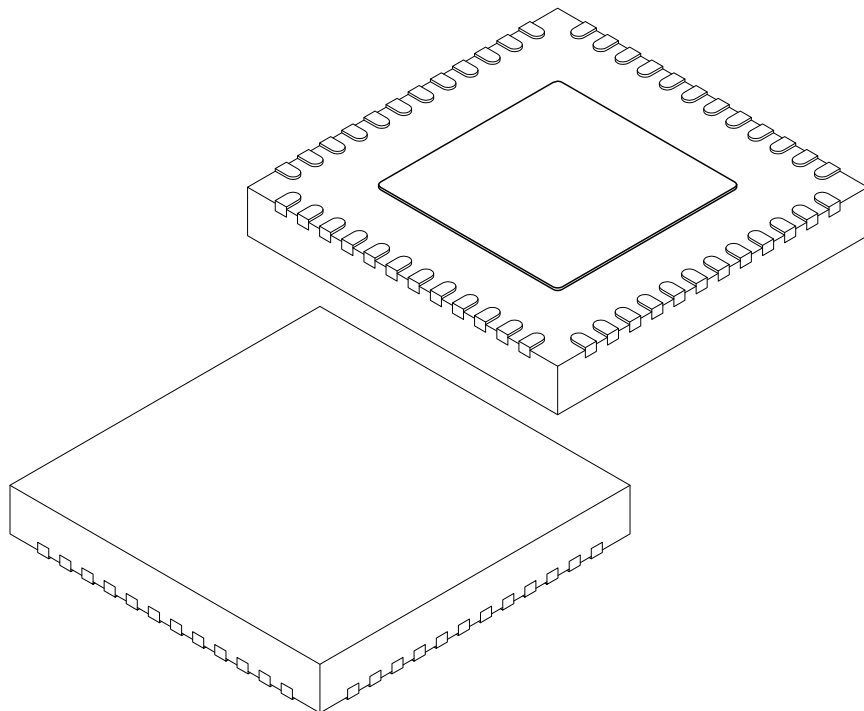

Dimension Limits	Units	MILLIMETERS		
		MIN	NOM	MAX
Number of Terminals	N	48		
Pitch	e	0.50 BSC		
Overall Height	A	0.80	0.90	1.00
Standoff	A1	0.00	0.02	0.05
Terminal Thickness	A3	0.20 REF		
Overall Length	D	7.00 BSC		
Exposed Pad Length	D2	4.00	4.10	4.20
Overall Width	E	7.00 BSC		
Exposed Pad Width	E2	4.00	4.10	4.20
Terminal Width	b	0.18	0.25	0.30
Terminal Length	L	0.30	0.40	0.50
Terminal-to-Exposed-Pad	K	0.20	-	-

**Notes:**

- Pin 1 visual index feature may vary, but must be located within the hatched area.
- Package is saw singulated
- Dimensioning and tolerancing per ASME Y14.5M

BSC: Basic Dimension. Theoretically exact value shown without tolerances.

REF: Reference Dimension, usually without tolerance, for information purposes only.

---



---

## Footprint Outlines and Dimensions

---



---

### 48-Lead Very Thin Quad Flat, No Lead Package [ML] - 7x7x1.0 mm Body [VQFN] With 4.1x4.1 mm Exposed Pad

**Note:** For the most current package drawings, please see the Microchip Packaging Specification located at <http://www.microchip.com/packaging>

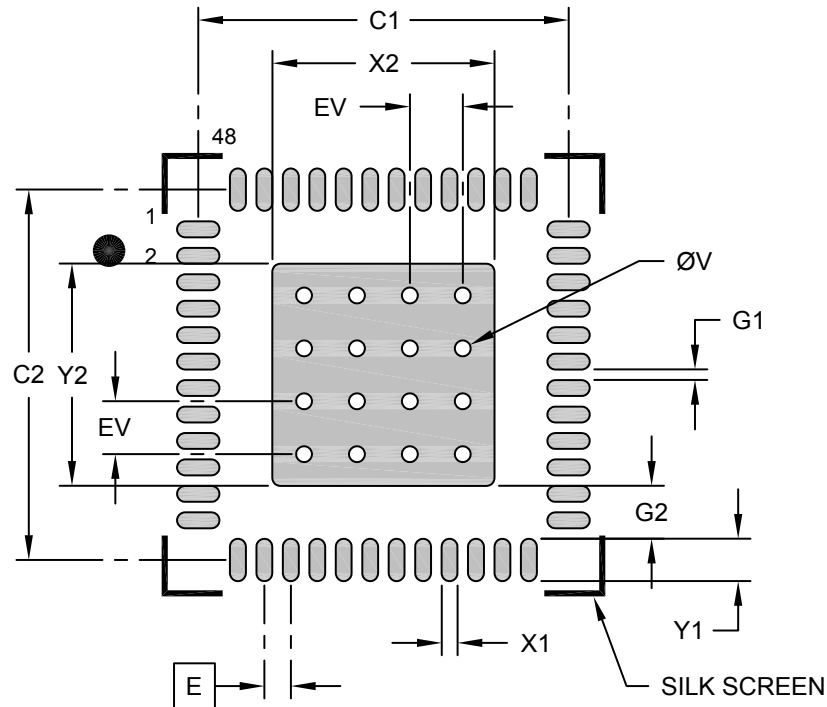

### RECOMMENDED LAND PATTERN

	Units	MILLIMETERS		
		MIN	NOM	MAX
Dimension Limits				
Contact Pitch	E	0.50 BSC		
Optional Center Pad Width	X2			4.20
Optional Center Pad Length	Y2			4.20
Contact Pad Spacing	C1		7.00	
Contact Pad Spacing	C2		7.00	
Contact Pad Width (X48)	X1			0.30
Contact Pad Length (X48)	Y1			0.80
Contact Pad to Contact Pad (X44)	G1	0.20		
Contact Pad to Center Pad (X48)	G2	1.00		
Thermal Via Diameter	V		0.30	
Thermal Via Pitch	EV		1.00	

**Notes:**

1. Dimensioning and tolerancing per ASME Y14.5M  
BSC: Basic Dimension. Theoretically exact value shown without tolerances.
2. For best soldering results, thermal vias, if used, should be filled or tented to avoid solder loss during reflow process

**Package Outlines and Dimensions**

**48-Lead Very Thin Quad Flat, No Lead Package [Y3X] - 7x7x1.0 mm Body [VQFN]  
With 4.1x4.1 mm Exposed Pad**

**Note:** For the most current package drawings, please see the Microchip Packaging Specification located at <http://www.microchip.com/packaging>

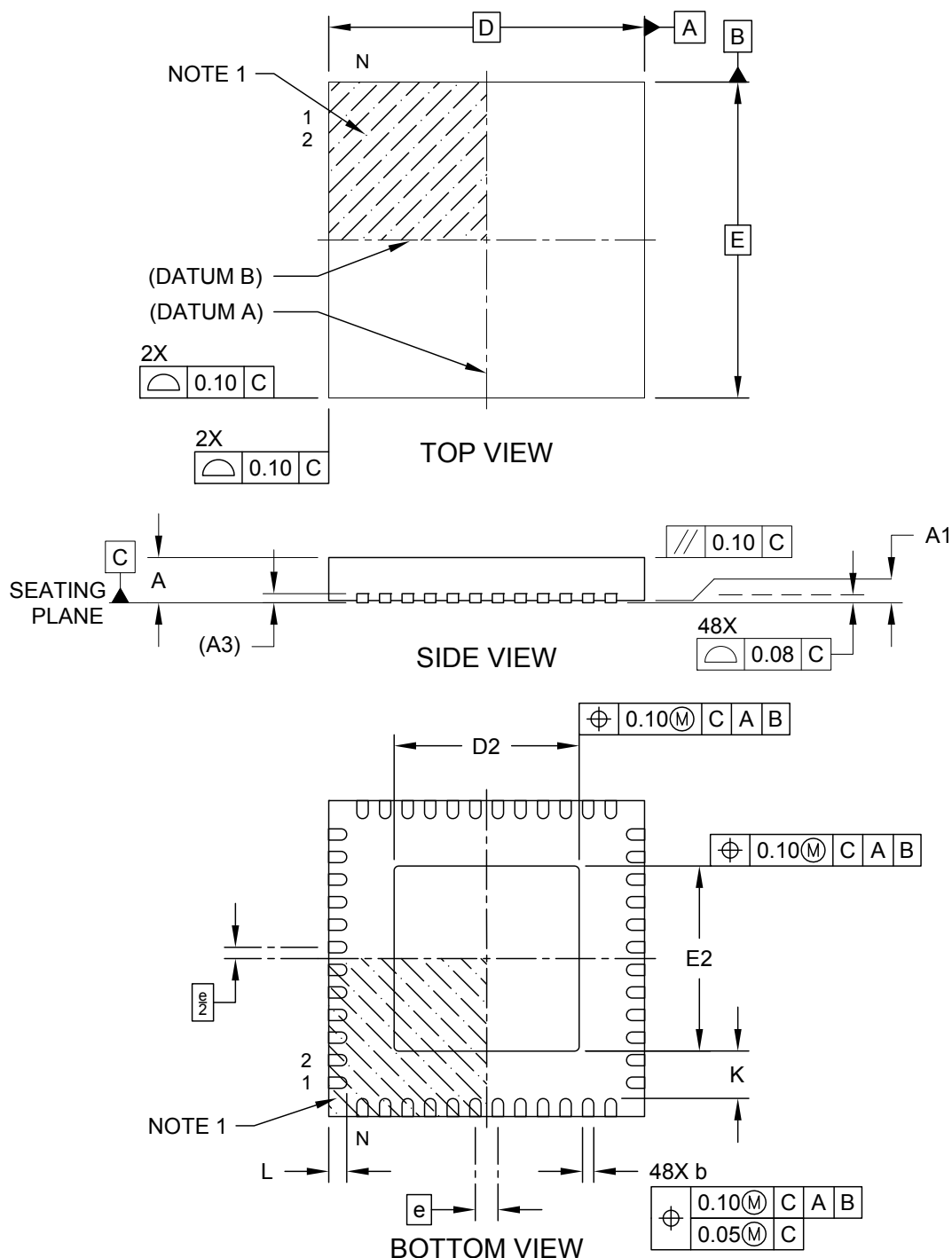

---



---

## Package Outlines and Dimensions

---



---

### 48-Lead Very Thin Quad Flat, No Lead Package [Y3X] - 7x7x1.0 mm Body [VQFN] With 4.1x4.1 mm Exposed Pad

**Note:** For the most current package drawings, please see the Microchip Packaging Specification located at <http://www.microchip.com/packaging>

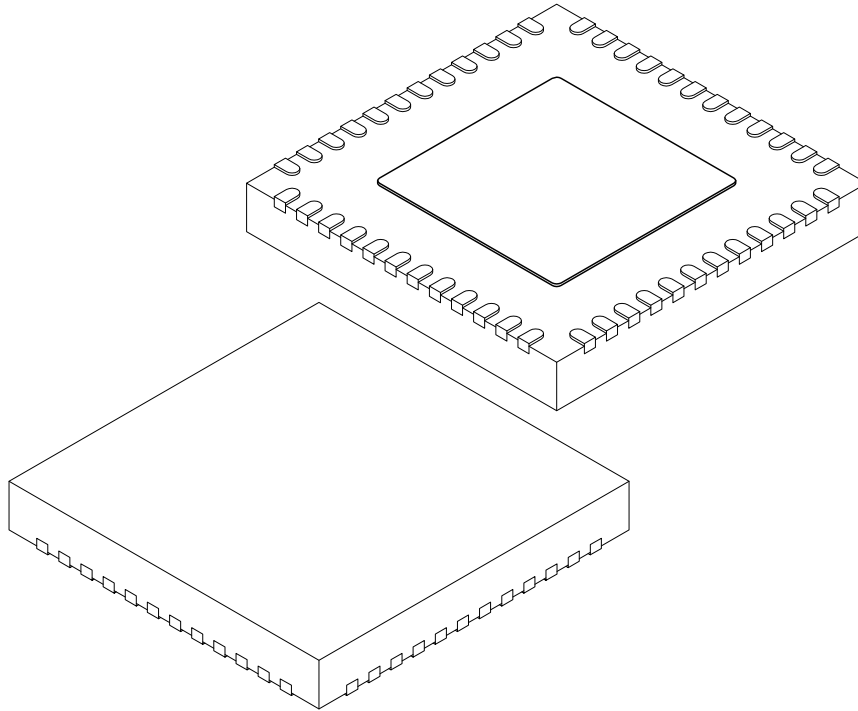

Dimension Limits	Units	MILLIMETERS		
		MIN	NOM	MAX
Number of Terminals	N	48		
Pitch	e	0.50 BSC		
Overall Height	A	0.80	0.90	1.00
Standoff	A1	0.00	0.02	0.05
Terminal Thickness	A3	0.20 REF		
Overall Length	D	7.00 BSC		
Exposed Pad Length	D2	4.00	4.10	4.20
Overall Width	E	7.00 BSC		
Exposed Pad Width	E2	4.00	4.10	4.20
Terminal Width	b	0.18	0.25	0.30
Terminal Length	L	0.30	0.40	0.50
Terminal-to-Exposed-Pad	K	0.20	-	-

**Notes:**

1. Pin 1 visual index feature may vary, but must be located within the hatched area.
2. Package is saw singulated
3. Dimensioning and tolerancing per ASME Y14.5M

BSC: Basic Dimension. Theoretically exact value shown without tolerances.

REF: Reference Dimension, usually without tolerance, for information purposes only.

**Footprint Outlines and Dimensions**

**48-Lead Very Thin Quad Flat, No Lead Package [Y3X] - 7x7x1.0 mm Body [VQFN]  
With 4.1x4.1 mm Exposed Pad**

**Note:** For the most current package drawings, please see the Microchip Packaging Specification located at <http://www.microchip.com/packaging>

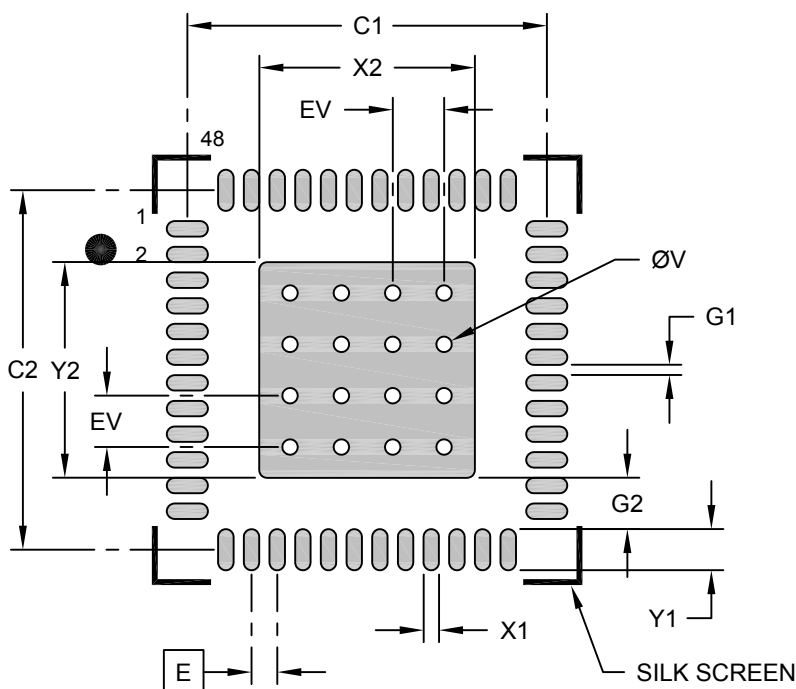

**RECOMMENDED LAND PATTERN**

Dimension Limits	Units	MILLIMETERS		
		MIN	NOM	MAX
Contact Pitch	E	0.50 BSC		
Optional Center Pad Width	X2			4.20
Optional Center Pad Length	Y2			4.20
Contact Pad Spacing	C1		7.00	
Contact Pad Spacing	C2		7.00	
Contact Pad Width (X48)	X1			0.30
Contact Pad Length (X48)	Y1			0.80
Contact Pad to Contact Pad (X44)	G1	0.20		
Contact Pad to Center Pad (X48)	G2	1.00		
Thermal Via Diameter	V		0.30	
Thermal Via Pitch	EV		1.00	

**Notes:**

1. Dimensioning and tolerancing per ASME Y14.5M  
BSC: Basic Dimension. Theoretically exact value shown without tolerances.
2. For best soldering results, thermal vias, if used, should be filled or tented to avoid solder loss during reflow process

**Package Outlines and Dimensions**

**48-Lead Very Thin Quad Flat, No Lead Package [ML] - 7x7x1.0 mm Body [VQFN]  
With 5.3x5.3 mm Exposed Pad**

**Note:** For the most current package drawings, please see the Microchip Packaging Specification located at <http://www.microchip.com/packaging>

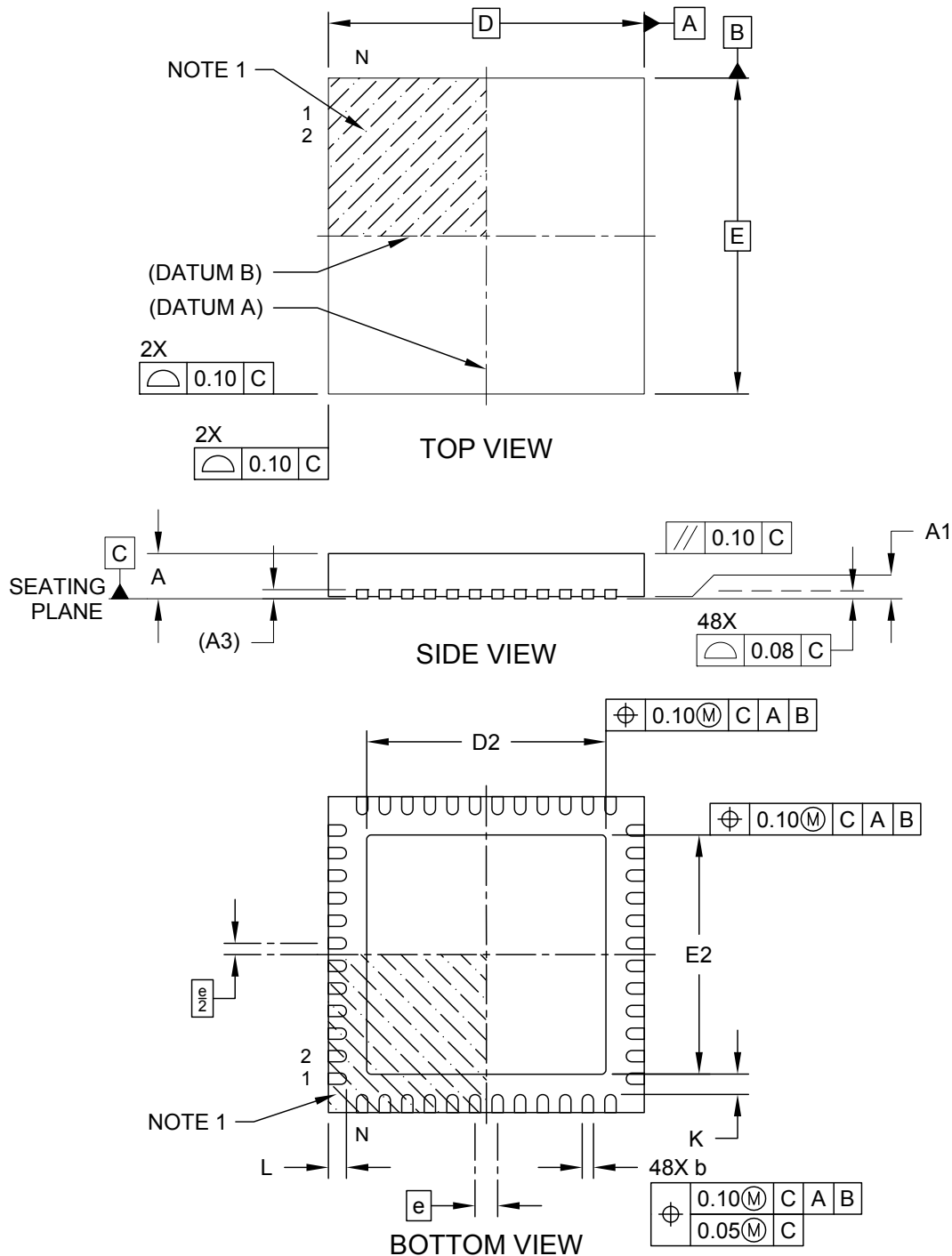

**Package Outlines and Dimensions**

**48-Lead Very Thin Quad Flat, No Lead Package [ML] - 7x7x1.0 mm Body [VQFN]  
With 5.3x5.3 mm Exposed Pad**

**Note:** For the most current package drawings, please see the Microchip Packaging Specification located at <http://www.microchip.com/packaging>

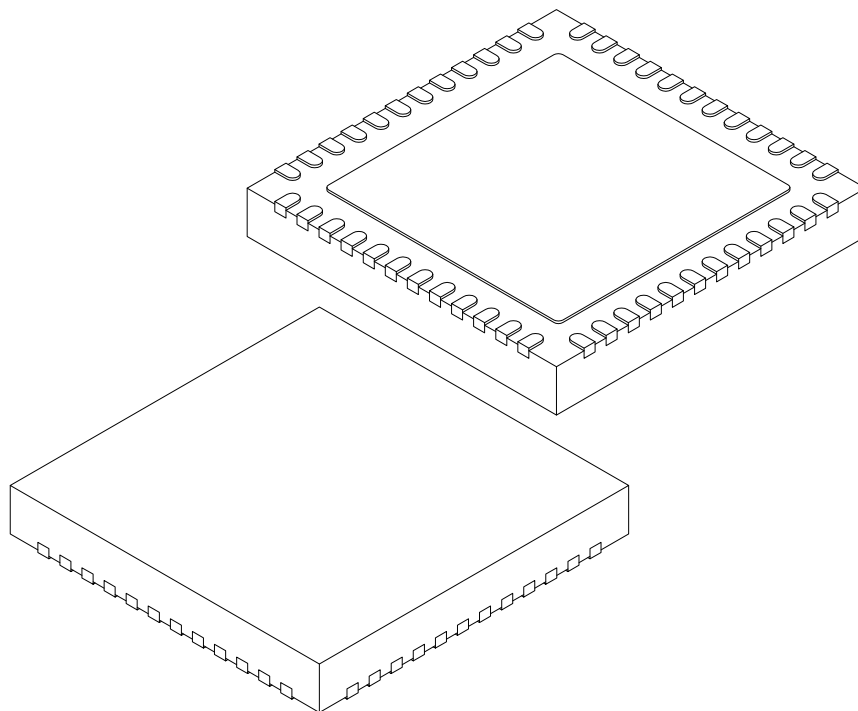

		Units	MILLIMETERS		
Dimension Limits			MIN	NOM	MAX
Number of Terminals	N		48		
Pitch	e		0.50 BSC		
Overall Height	A	0.80	0.90	1.00	
Standoff	A1	0.00	0.02	0.05	
Terminal Thickness	A3	0.20 REF			
Overall Length	D	7.00 BSC			
Exposed Pad Length	D2	5.20	5.30	5.40	
Overall Width	E	7.00 BSC			
Exposed Pad Width	E2	5.20	5.30	5.40	
Terminal Width	b	0.18	0.25	0.30	
Terminal Length	L	0.30	0.40	0.50	
Terminal-to-Exposed-Pad	K	0.20	-	-	

**Notes:**

- Pin 1 visual index feature may vary, but must be located within the hatched area.
- Package is saw singulated
- Dimensioning and tolerancing per ASME Y14.5M

BSC: Basic Dimension. Theoretically exact value shown without tolerances.

REF: Reference Dimension, usually without tolerance, for information purposes only.



---



---

## Footprint Outlines and Dimensions

---



---

### 48-Lead Very Thin Quad Flat, No Lead Package [ML] - 7x7x1.0 mm Body [VQFN] With 5.3x5.3 mm Exposed Pad

**Note:** For the most current package drawings, please see the Microchip Packaging Specification located at <http://www.microchip.com/packaging>

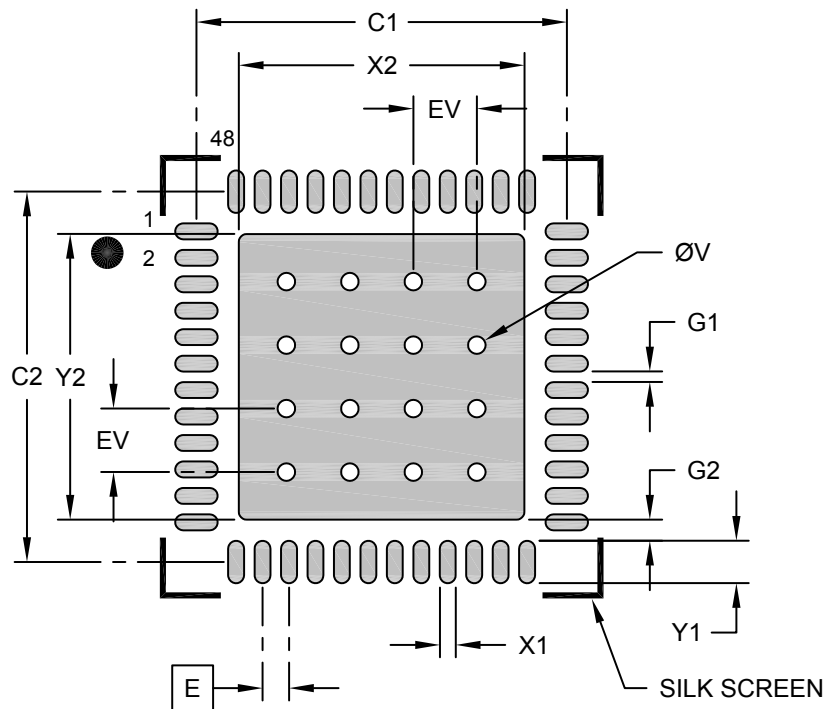

### RECOMMENDED LAND PATTERN

Dimension Limits	Units	MILLIMETERS		
		MIN	NOM	MAX
Contact Pitch	E	0.50 BSC		
Optional Center Pad Width	X2			5.40
Optional Center Pad Length	Y2			5.40
Contact Pad Spacing	C1		7.00	
Contact Pad Spacing	C2		7.00	
Contact Pad Width (X48)	X1			0.30
Contact Pad Length (X48)	Y1			0.80
Contact Pad to Contact Pad (X44)	G1	0.20		
Contact Pad to Center Pad (X48)	G2	0.40		
Thermal Via Diameter	V		0.33	
Thermal Via Pitch	EV		1.20	

**Notes:**

- Dimensioning and tolerancing per ASME Y14.5M  
BSC: Basic Dimension. Theoretically exact value shown without tolerances.
- For best soldering results, thermal vias, if used, should be filled or tented to avoid solder loss during reflow process

Package Outlines and Dimensions

**48-Lead Very Thin Quad Flat, No Lead Package [Y9X] - 7x7x1.0 mm Body [VQFN]  
With 5.3x5.3 mm Exposed Pad**

Note: For the most current package drawings, please see the Microchip Packaging Specification located at <http://www.microchip.com/packaging>

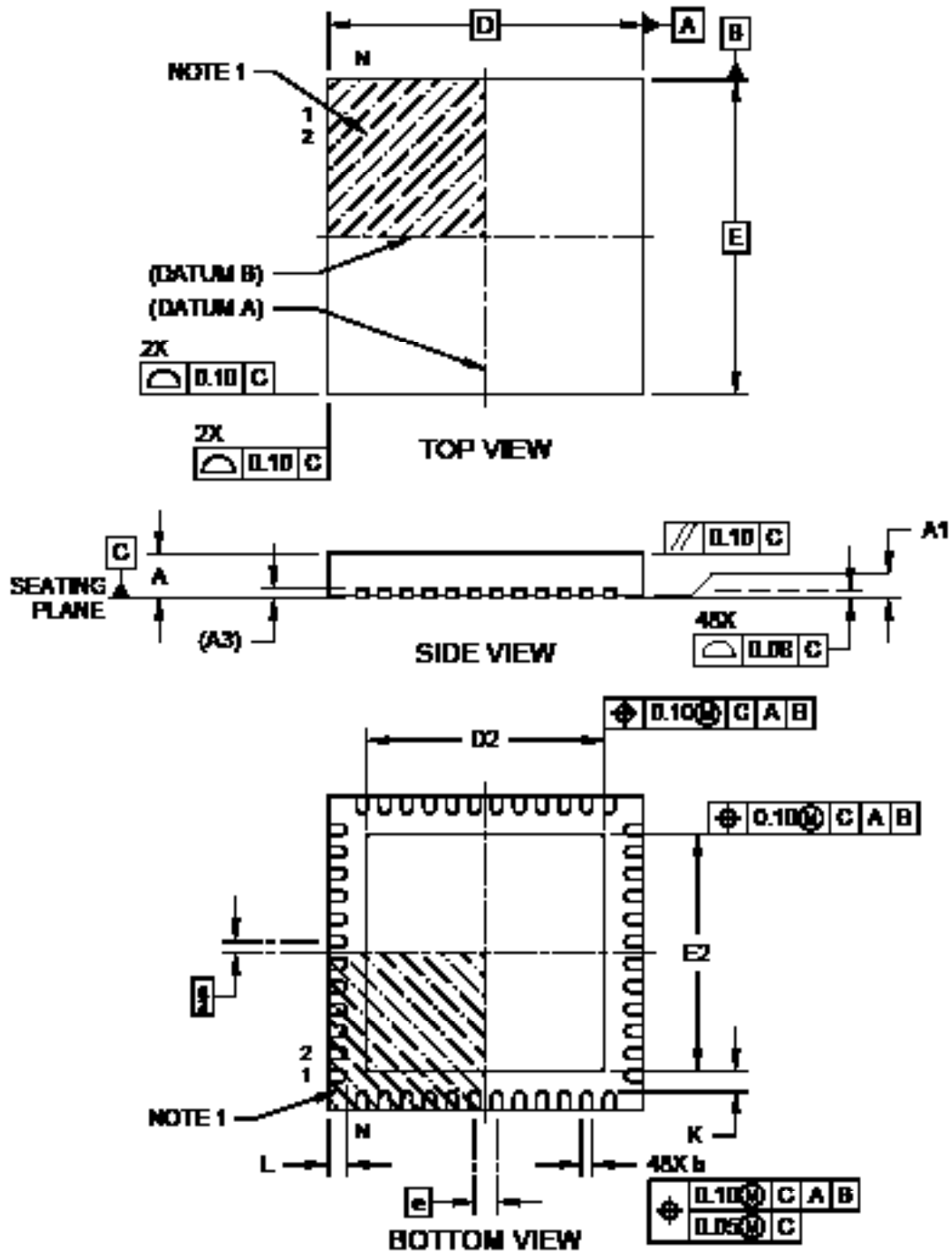

---



---

## Package Outlines and Dimensions

---



---

### 48-Lead Very Thin Quad Flat, No Lead Package [Y9X] - 7x7x1.0 mm Body [VQFN] With 5.3x5.3 mm Exposed Pad

**Note:** For the most current package drawings, please see the Microchip Packaging Specification located at <http://www.microchip.com/packaging>

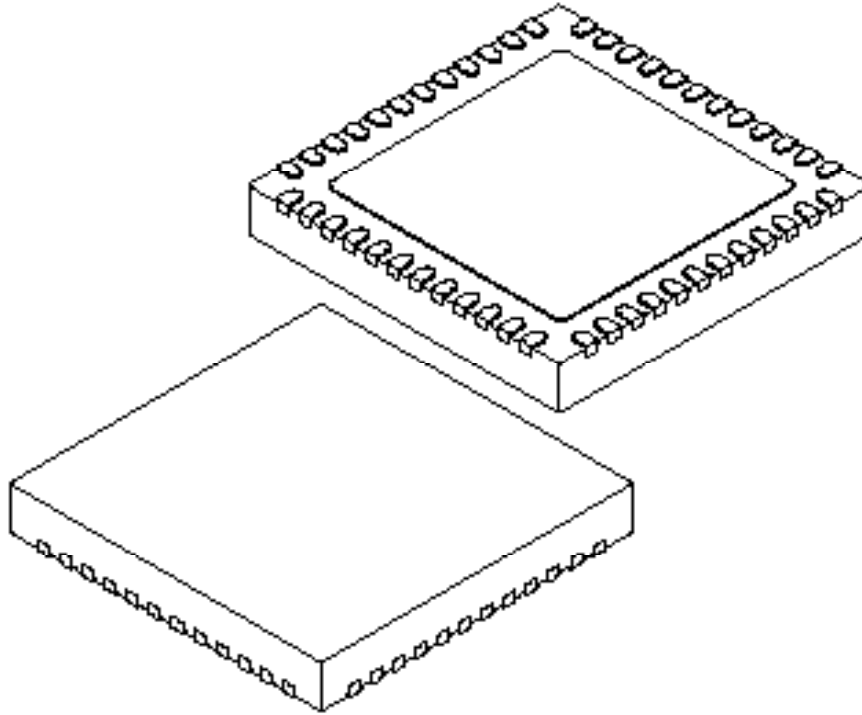

Dimension Limits	Units	MILLIMETERS		
		MIN	NCM	MAX
Number of Terminals	N	48		
Pitch	e	0.50 BSC		
Overall Height	A	0.80	0.90	1.00
Standoff	A1	0.00	0.02	0.05
Terminal Thickness	A3	0.20 REF		
Overall Length	D	7.00 BSC		
Exposed Pad Length	D2	5.20	5.30	5.40
Overall Width	E	7.00 BSC		
Exposed Pad Width	E2	5.20	5.30	5.40
Terminal Width	b	0.18	0.25	0.30
Terminal Length	L	0.30	0.40	0.50
Terminal-to-Exposed-Pad	K	0.20	-	-

**Notes:**

1. Pin 1 visual index feature may vary, but must be located within the hatched area.
2. Package is saw singulated.
3. Dimensioning and tolerancing per ASME Y14.5M

BSC: Basic Dimension. Theoretically exact value shown without tolerances.

REF: Reference Dimension, usually without tolerance, for information purposes only.

**Footprint Outlines and Dimensions**

**48-Lead Very Thin Quad Flat, No Lead Package [Y9X] - 7x7x1.0 mm Body [VQFN]  
With 5.3x5.3 mm Exposed Pad**

**Note:** For the most current package drawings, please see the Microchip Packaging Specification located at <http://www.microchip.com/packaging>

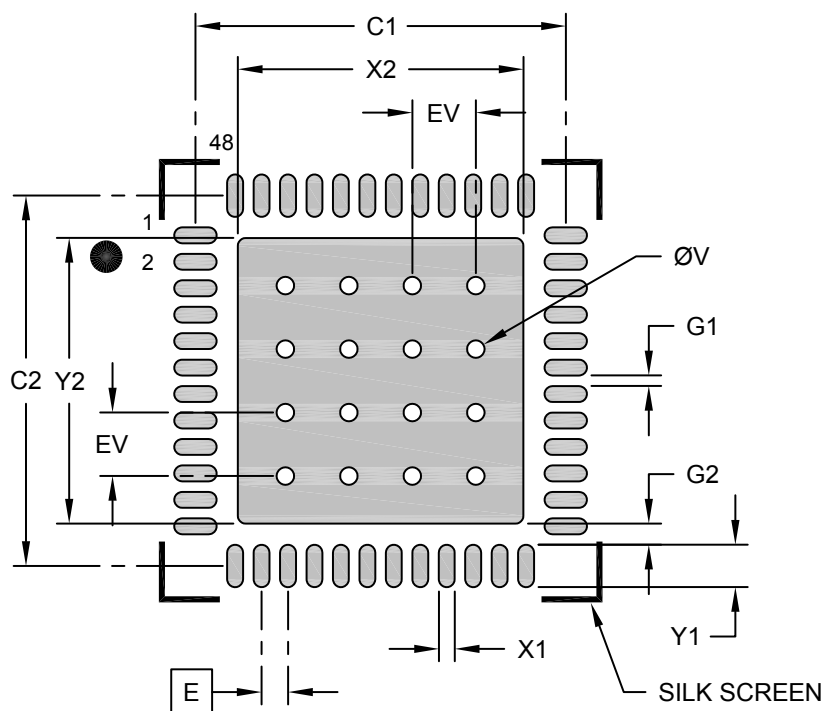

**RECOMMENDED LAND PATTERN**

Dimension Limits	Units	MILLIMETERS		
		MIN	NOM	MAX
Contact Pitch	E	0.50 BSC		
Optional Center Pad Width	X2			5.40
Optional Center Pad Length	Y2			5.40
Contact Pad Spacing	C1		7.00	
Contact Pad Spacing	C2		7.00	
Contact Pad Width (X48)	X1			0.30
Contact Pad Length (X48)	Y1			0.80
Contact Pad to Contact Pad (X44)	G1	0.20		
Contact Pad to Center Pad (X48)	G2	0.40		
Thermal Via Diameter	V		0.33	
Thermal Via Pitch	EV		1.20	

**Notes:**

1. Dimensioning and tolerancing per ASME Y14.5M  
BSC: Basic Dimension. Theoretically exact value shown without tolerances.
2. For best soldering results, thermal vias, if used, should be filled or tented to avoid solder loss during reflow process

**Package Outlines and Dimensions**

**48-Lead Plastic Quad Flat, No Lead Package (RS) - 7x7 mm Body [VQFN]  
With Exposed Pad; Punch Singulated (AIS Package HZH)**

**Note:** For the most current package drawings, please see the Microchip Packaging Specification located at <http://www.microchip.com/packaging>

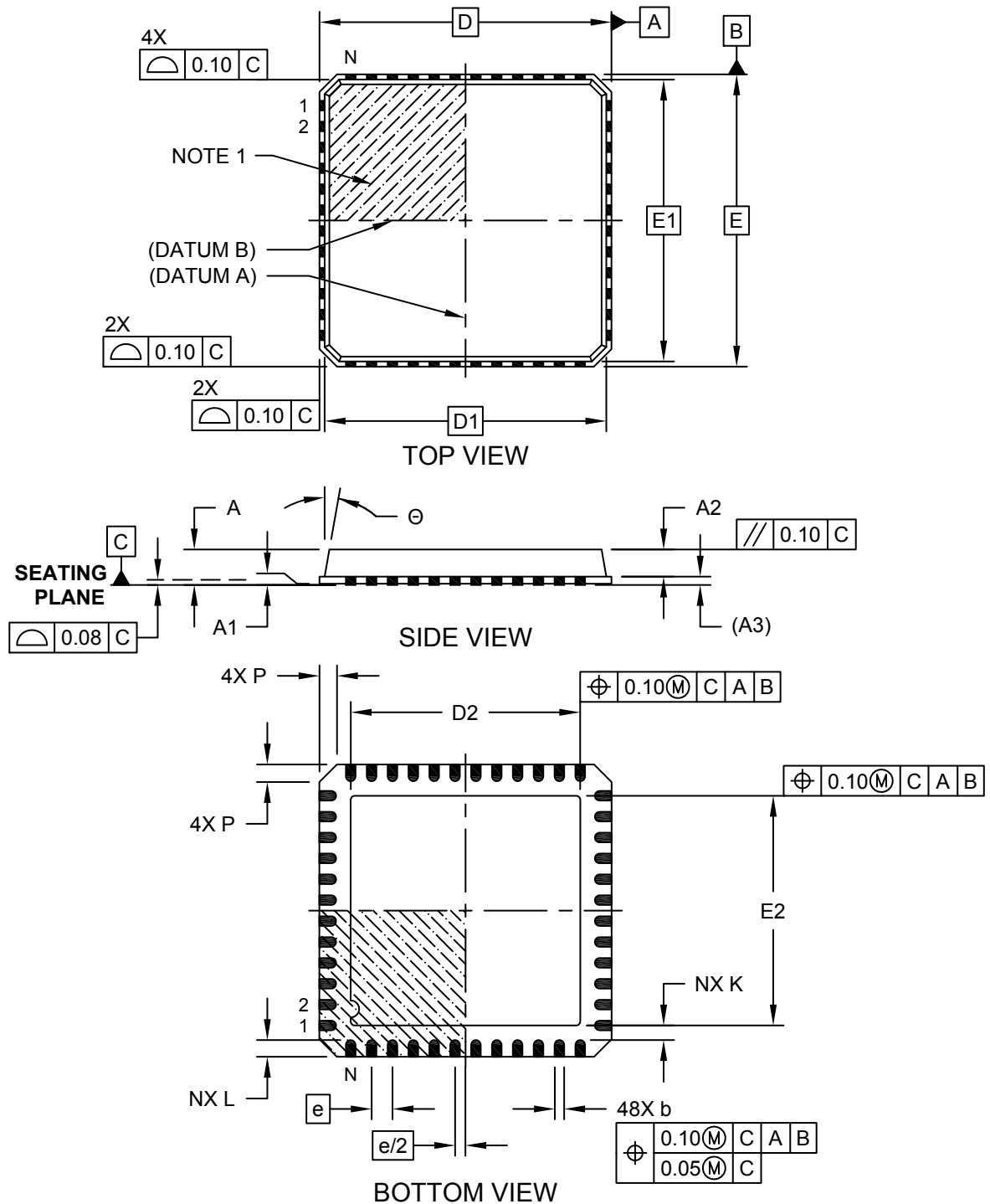

**Package Outlines and Dimensions**

**48-Lead Plastic Quad Flat, No Lead Package (RS) - 7x7 mm Body [VQFN]  
With Exposed Pad; Punch Singulated (AIS Package HZH)**

**Note:** For the most current package drawings, please see the Microchip Packaging Specification located at <http://www.microchip.com/packaging>

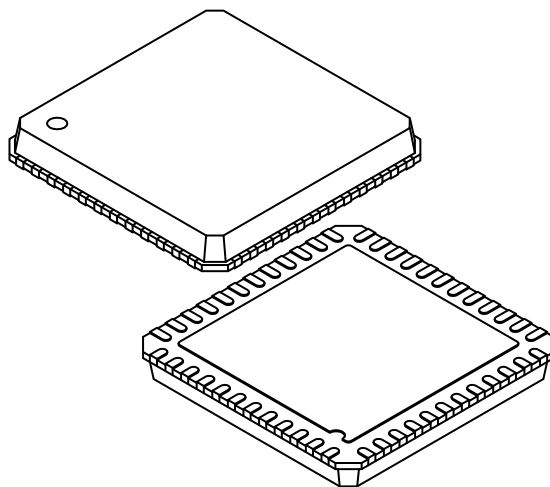

		Units	MILLIMETERS		
Dimension Limits			MIN	NOM	MAX
Number of Terminals	N		48		
Pitch	e		0.50 BSC		
Overall Height	A		0.80	0.85	0.90
Standoff	A1		0.00	0.01	0.05
Mold Cap Height	A2		0.60	0.65	0.70
Terminal Thickness	(A3)		0.20 REF		
Overall Width	E		7.00 BSC		
Molded Top Width	E1		6.75 BSC		
Exposed Pad Width	E2		(See Exposed Pad Variations)		
Overall Length	D		7.00 BSC		
Molded Top Length	D1		6.75 BSC		
Exposed Pad Length	D2		(See Exposed Pad Variations)		
Corner Chamfer	P		0.24	0.42	0.60
Terminal Width	b		0.18	0.23	0.30
Terminal Length	L		0.30	0.40	0.50
Terminal-to-Exposed-Pad	K		0.20	-	-
Mold Draft Angle	θ		0°	-	12°

Exposed Pad Variations						
Symbol	D2			E2		
Variant	MIN	NOM	MAX	MIN	NOM	MAX
C	4.00	4.10	4.20	4.00	4.10	4.20
G	5.00	5.10	5.20	5.00	5.10	5.20
H	5.20	5.30	5.40	5.20	5.30	5.40
K	5.40	5.50	5.60	5.40	5.50	5.60

Notes:

1. Pin 1 visual index feature may vary, but must be located within the hatched area.
2. Package is punch singulated
3. Dimensioning and tolerancing per ASME Y14.5M

BSC: Basic Dimension. Theoretically exact value shown without tolerances.

REF: Reference Dimension, usually without tolerance, for information purposes only.

---



---

## Footprint Outlines and Dimensions

---



---

### 48-Lead Plastic Quad Flat, No Lead Package (RS) - 7x7 mm Body [VQFN] With Exposed Pad; Punch Singulated (AIS Package HZH)

**Note:** For the most current package drawings, please see the Microchip Packaging Specification located at <http://www.microchip.com/packaging>

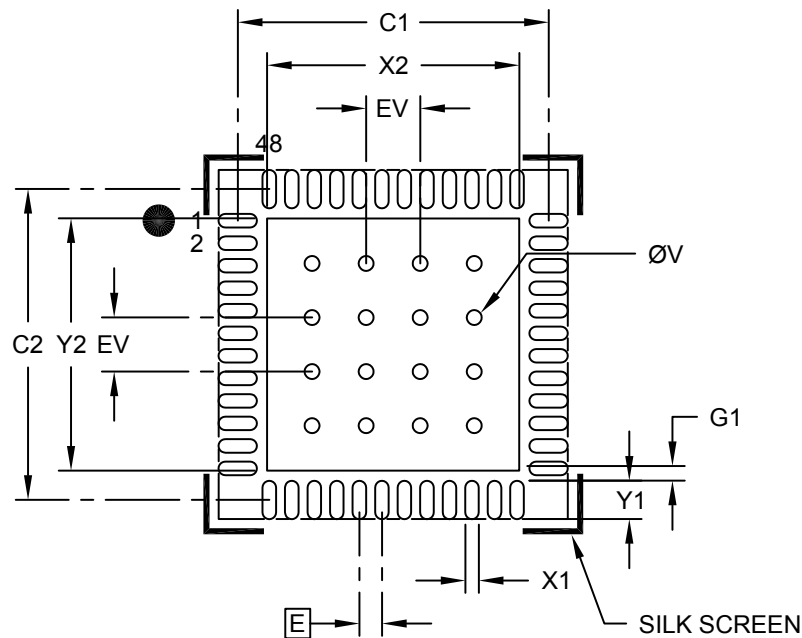

### RECOMMENDED LAND PATTERN

	Units	MILLIMETERS		
		MIN	NOM	MAX
Contact Pitch	E	0.50 BSC		
Optional Center Pad Width	X2	See Center Pad Variations		
Optional Center Pad Length	Y2	See Center Pad Variations		
Contact Pad Spacing	C1	6.90		
Contact Pad Spacing	C2	6.90		
Contact Pad Width (X48)	X1			0.30
Contact Pad Length (X48)	Y1			0.85
Contact Pad to Center Pad (X48)	G1	0.20		
Thermal Via Diameter	V	0.33		
Thermal Via Pitch	EV	1.20		

Center Pad Variations						
Symbol	X2			Y2		
	MIN	NOM	MAX	MIN	NOM	MAX
C			4.20			4.20
G			5.20			5.20
H			5.40			5.40
K			5.60			5.60

**Notes:**

- Dimensioning and tolerancing per ASME Y14.5M  
BSC: Basic Dimension. Theoretically exact value shown without tolerances.
- For best soldering results, thermal vias, if used, should be filled or tented to avoid solder loss during reflow process

**Package Outlines and Dimensions**

**48-Lead Very Thin Plastic Quad Flat, No Lead Package (VQ) - 7x7 mm Body [VQFN]  
With 5.3 mm Exposed Pad; Punch Singulated**

**Note:** For the most current package drawings, please see the Microchip Packaging Specification located at <http://www.microchip.com/packaging>

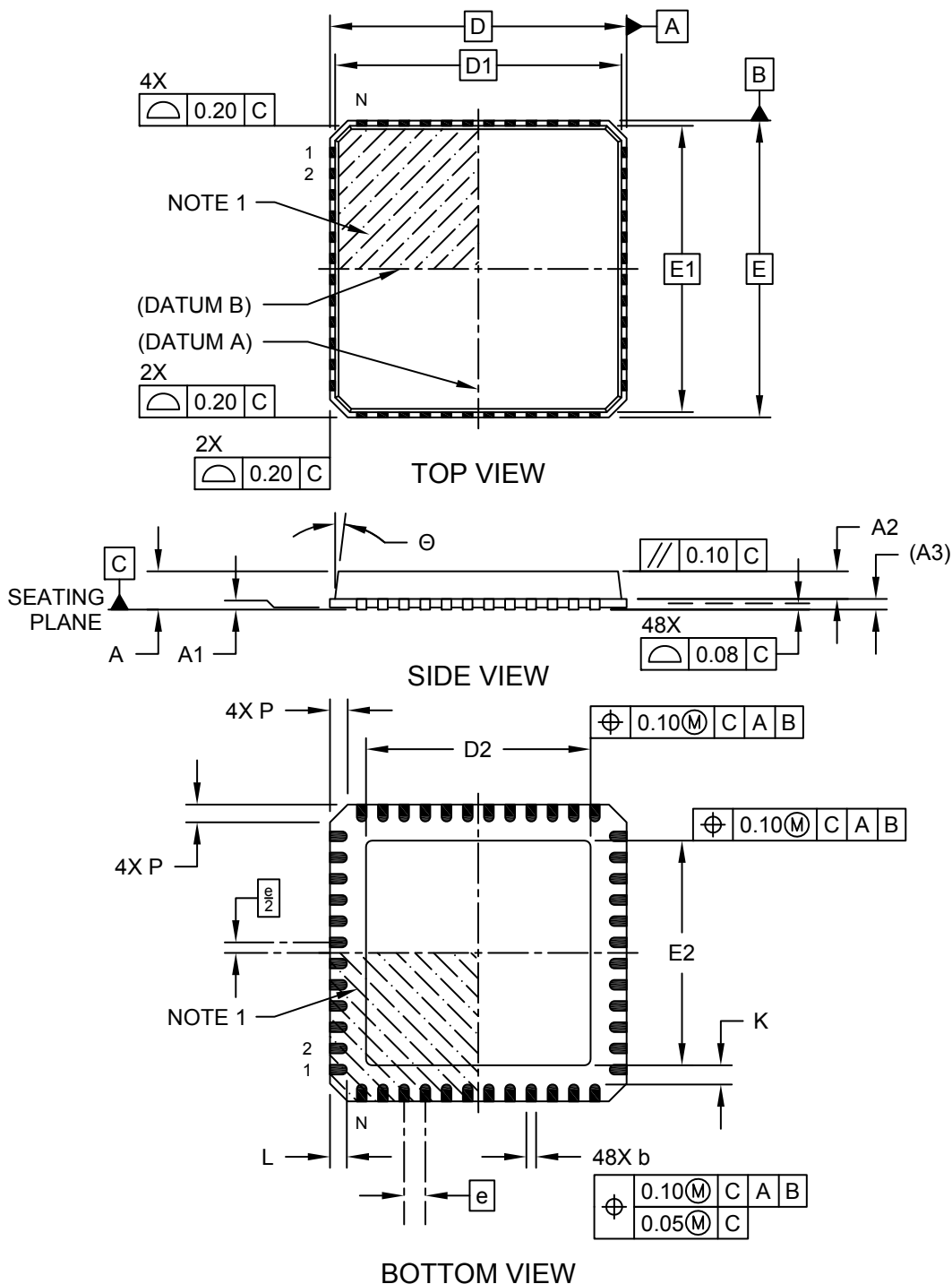



---



---

## Package Outlines and Dimensions

---



---

### 48-Lead Very Thin Plastic Quad Flat, No Lead Package (VQ) - 7x7 mm Body [VQFN] With 5.3 mm Exposed Pad; Punch Singulated

**Note:** For the most current package drawings, please see the Microchip Packaging Specification located at <http://www.microchip.com/packaging>

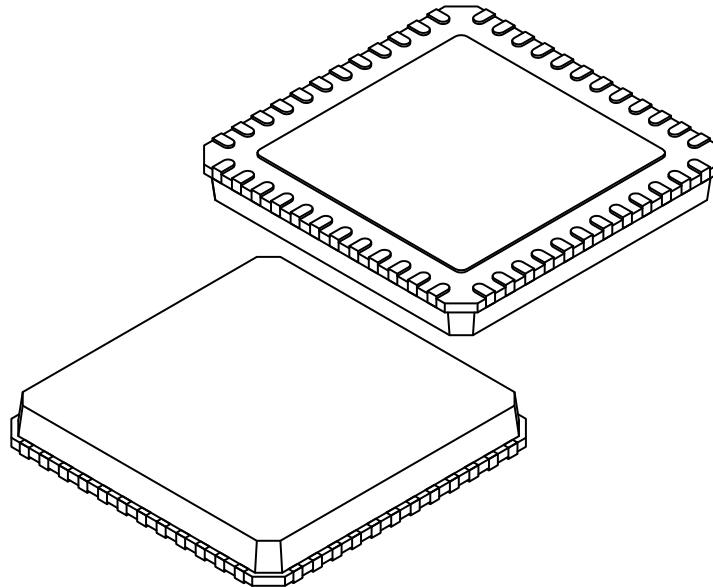

		Units	MILLIMETERS		
Dimension Limits			MIN	NOM	MAX
Number of Terminals	N		48		
Pitch	e		0.50 BSC		
Overall Height	A	0.80	0.85	0.90	
Standoff	A1	0.00	0.02	0.05	
Mold Cap Thickness	A2	0.60	0.65	0.70	
Terminal Thickness	(A3)		0.20 REF		
Overall Length	D		7.00 BSC		
Mold Cap Length	D1		6.75 BSC		
Exposed Pad Length	D2	5.20	5.30	5.40	
Overall Width	E		7.00 BSC		
Mold Cap Width	E1		6.75 BSC		
Exposed Pad Width	E2	5.20	5.30	5.40	
Corner Chamfer	P	0.24	0.42	0.60	
Terminal Width	b	0.18	0.23	0.30	
Terminal Length	L	0.30	0.40	0.50	
Terminal-to-Exposed-Pad	K	0.20	-	-	
Mold Cap Draft Angle	Θ	0°	-	14°	

**Notes:**

1. Pin 1 visual index feature may vary, but must be located within the hatched area.
2. Package is punch singulated
3. Dimensioning and tolerancing per ASME Y14.5M
  - BSC: Basic Dimension. Theoretically exact value shown without tolerances.
  - REF: Reference Dimension, usually without tolerance, for information purposes only.

**Footprint Outlines and Dimensions**

**48-Lead Very Thin Plastic Quad Flat, No Lead Package (VQ) - 7x7 mm Body [VQFN]  
With 5.3 mm Exposed Pad; Punch Singulated**

**Note:** For the most current package drawings, please see the Microchip Packaging Specification located at <http://www.microchip.com/packaging>

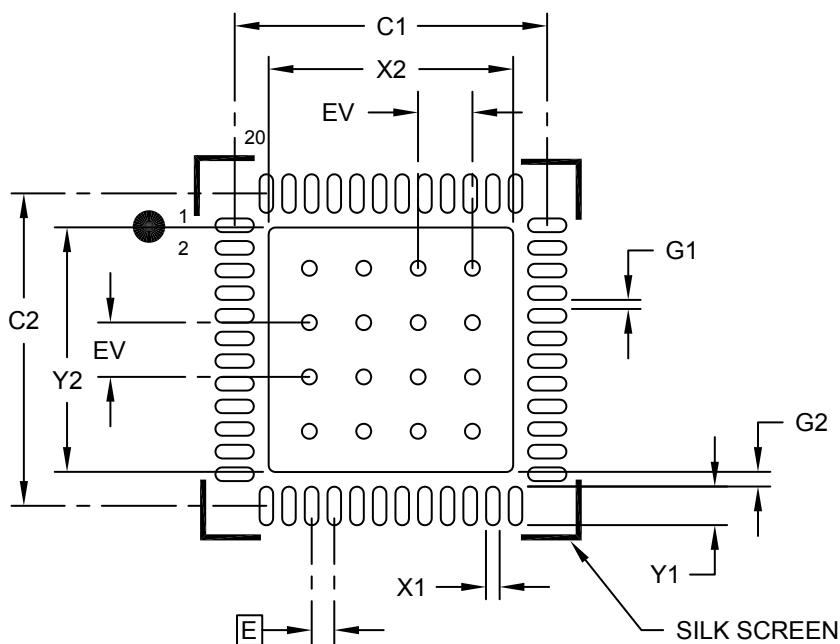

**RECOMMENDED LAND PATTERN**

Dimension Limits	Units	MILLIMETERS		
		MIN	NOM	MAX
Contact Pitch	E	0.50 BSC		
Optional Center Pad Width	X2			5.40
Optional Center Pad Length	Y2			5.40
Contact Pad Spacing	C1		6.90	
Contact Pad Spacing	C2		6.90	
Contact Pad Width (X48)	X1			0.30
Contact Pad Length (X48)	Y1			0.85
Space Between Pads (X44)	G1	0.20		
Contact Pad to Center Pad (X48)	G2	0.20		
Thermal Via Diameter	V		0.33	
Thermal Via Pitch	EV		1.20	

**Notes:**

1. Dimensioning and tolerancing per ASME Y14.5M  
BSC: Basic Dimension. Theoretically exact value shown without tolerances.
2. For best soldering results, thermal vias, if used, should be filled or tented to avoid solder loss during reflow process

**Package Outlines and Dimensions**

**52-Lead Very Thin Plastic Quad Flat, No-Lead Package (8HX) - 8x8 mm Body [VQFN] With 6.6x6.6 mm Exposed Pad**

**Note:** For the most current package drawings, please see the Microchip Packaging Specification located at <http://www.microchip.com/packaging>

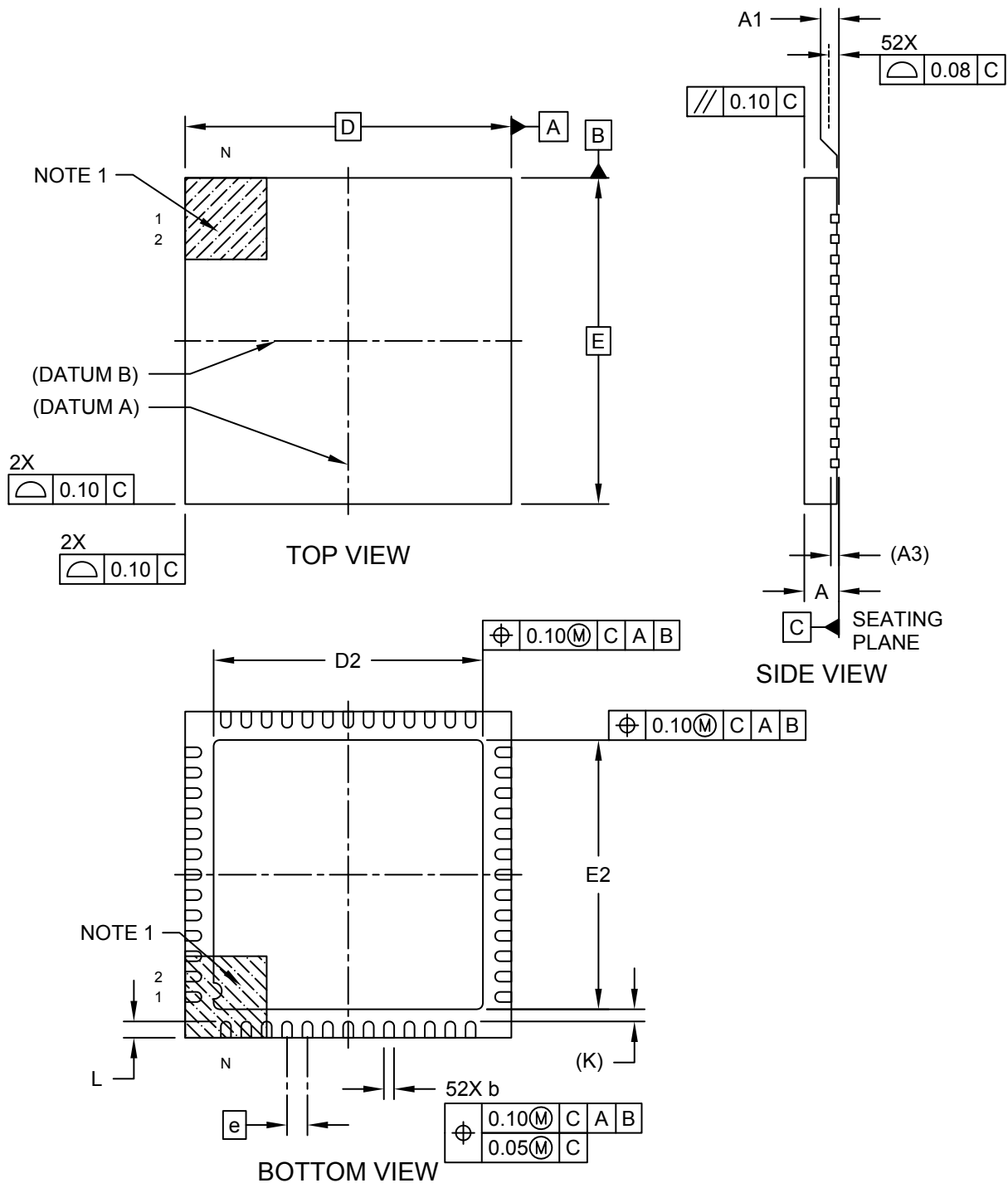

**Package Outlines and Dimensions**

**52-Lead Very Thin Plastic Quad Flat, No-Lead Package (8HX) - 8x8 mm Body [VQFN]  
With 6.6x6.6 mm Exposed Pad**

**Note:** For the most current package drawings, please see the Microchip Packaging Specification located at <http://www.microchip.com/packaging>

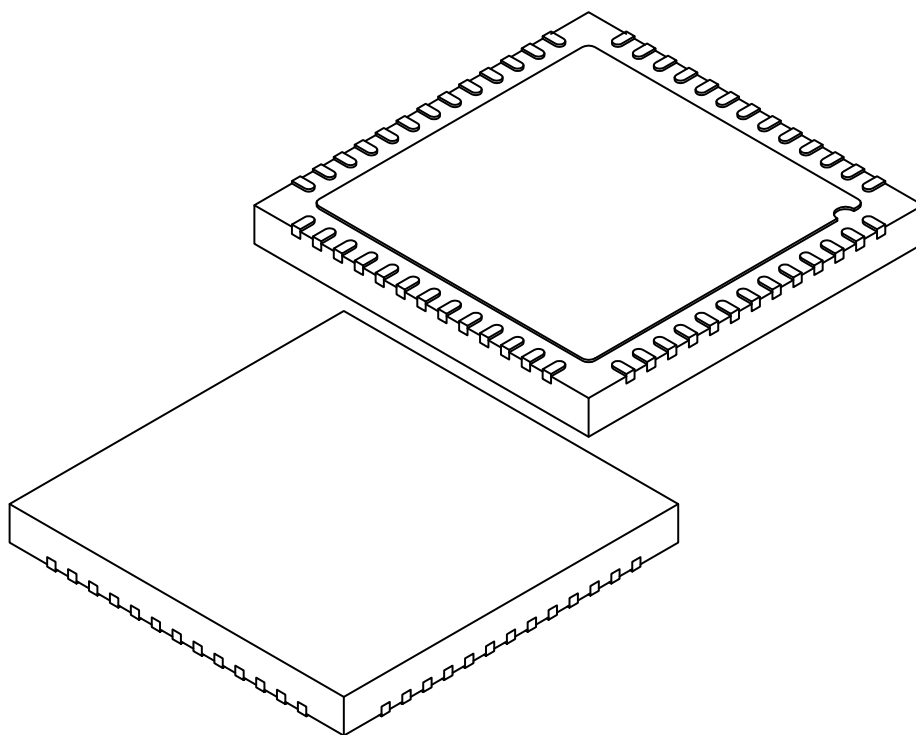

Dimension Limits	Units	MILLIMETERS		
		MIN	NOM	MAX
Number of Terminals	N	52		
Pitch	e	0.50 BSC		
Overall Height	A	0.80	0.85	0.90
Standoff	A1	0.00	0.02	0.05
Terminal Thickness	A3	0.20 REF		
Overall Length	D	8.00 BSC		
Exposed Pad Length	D2	6.50	6.60	6.70
Overall Width	E	8.00 BSC		
Exposed Pad Width	E2	6.50	6.60	6.70
Terminal Width	b	0.18	0.25	0.30
Terminal Length	L	0.35	0.40	0.45
Terminal-to-Exposed-Pad	K	0.30 REF		

**Notes:**

1. Pin 1 visual index feature may vary, but must be located within the hatched area.
2. Package is saw singulated
3. Dimensioning and tolerancing per ASME Y14.5M
  - BSC: Basic Dimension. Theoretically exact value shown without tolerances.
  - REF: Reference Dimension, usually without tolerance, for information purposes only.

---



---

## Footprint Outlines and Dimensions

---



---

### 52-Lead Very Thin Plastic Quad Flat, No-Lead Package (8HX) - 8x8 mm Body [VQFN] With 6.6x6.6 mm Exposed Pad

**Note:** For the most current package drawings, please see the Microchip Packaging Specification located at <http://www.microchip.com/packaging>

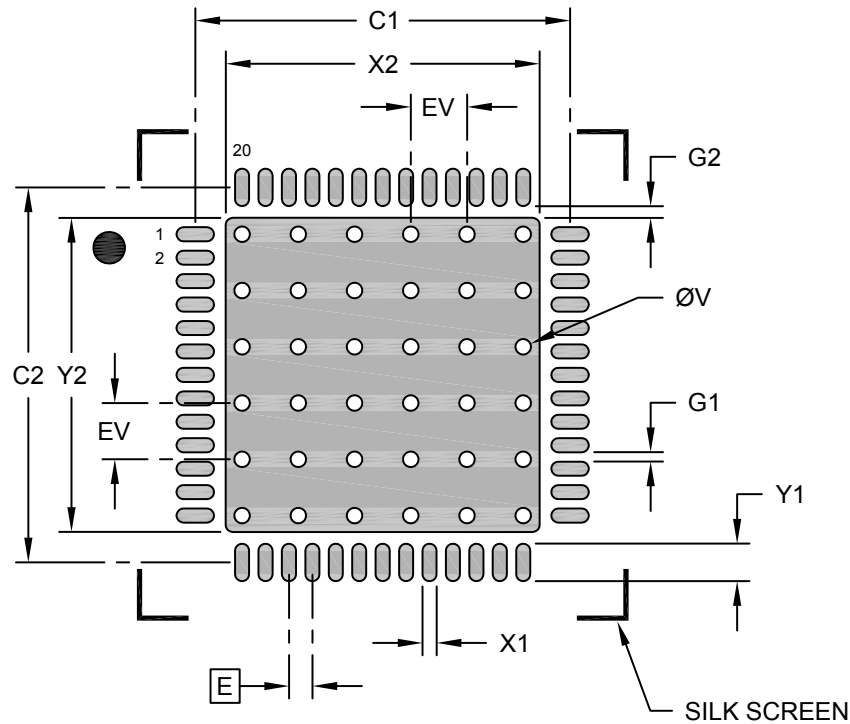

### RECOMMENDED LAND PATTERN

Dimension Limits	Units	MILLIMETERS		
		MIN	NOM	MAX
Contact Pitch	E	0.50 BSC		
Optional Center Pad Width	X2			6.70
Optional Center Pad Length	Y2			6.70
Contact Pad Spacing	C1		8.00	
Contact Pad Spacing	C2		8.00	
Contact Pad Width (X52)	X1			0.30
Contact Pad Length (X52)	Y1			0.80
Contact Pad to Contact Pad (X48)	G1	0.30		
Contact Pad to Center Pad (X52)	G2	0.25		
Thermal Via Diameter	V		0.33	
Thermal Via Pitch	EV		1.20	

**Notes:**

1. Dimensioning and tolerancing per ASME Y14.5M  
BSC: Basic Dimension. Theoretically exact value shown without tolerances.
2. For best soldering results, thermal vias, if used, should be filled or tented to avoid solder loss during reflow process

**Package Outlines and Dimensions**

**56-Lead Very Thin Plastic Quad Flat, No Lead Package (VU) - 7x7 mm Body [VQFN]**

**Note:** For the most current package drawings, please see the Microchip Packaging Specification located at <http://www.microchip.com/packaging>

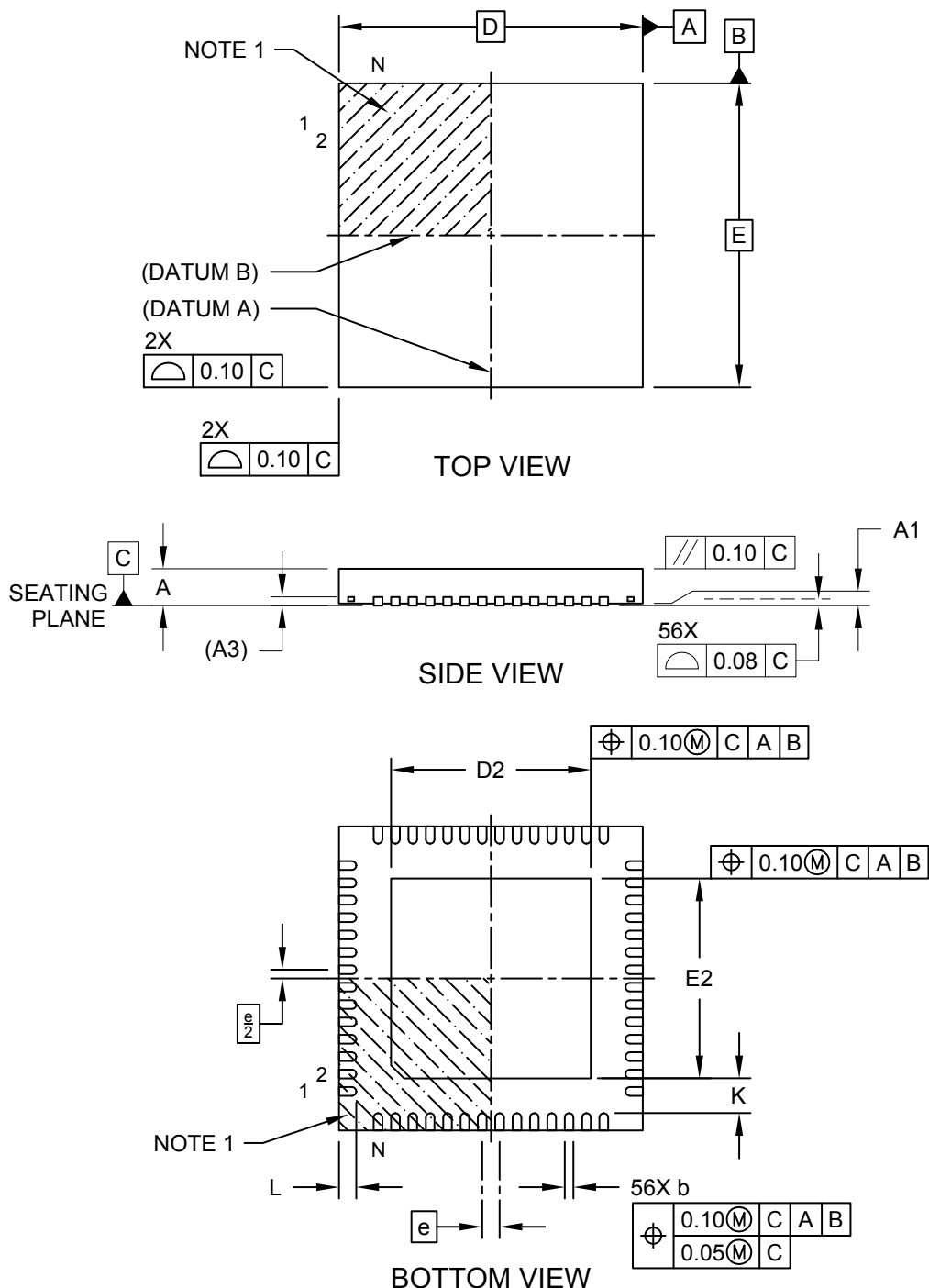

---



---

## Package Outlines and Dimensions

---



---

### 56-Lead Very Thin Plastic Quad Flat, No Lead Package (VU) - 7x7 mm Body [VQFN]

**Note:** For the most current package drawings, please see the Microchip Packaging Specification located at <http://www.microchip.com/packaging>

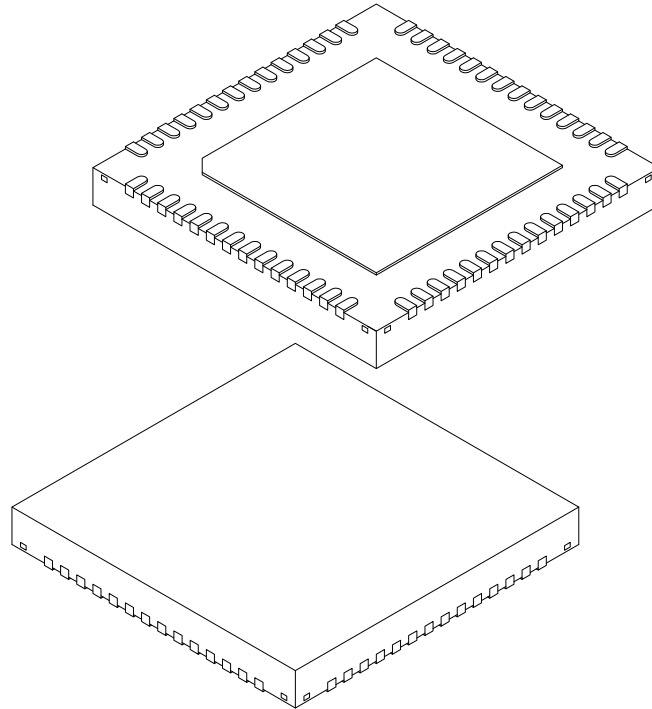

Units		MILLIMETERS		
Dimension Limits		MIN	NOM	MAX
Number of Terminals	N	56		
Pitch	e	0.40 BSC		
Overall Height	A	0.8	0.85	0.90
Standoff	A1	0.00	0.02	0.05
Terminal Thickness	A3	0.203 REF		
Overall Length	D	7.00 BSC		
Exposed Pad Length	D2	4.50	4.60	4.70
Overall Width	E	7.00 BSC		
Exposed Pad Width	E2	4.50	4.60	4.70
Terminal Width	b	0.15	0.20	0.25
Terminal Length	L	0.35	0.40	0.45
Terminal-to-Exposed-Pad	K	0.20	-	-

**Notes:**

1. Pin 1 visual index feature may vary, but must be located within the hatched area.
2. Package is saw singulated
3. Dimensioning and tolerancing per ASME Y14.5M

BSC: Basic Dimension. Theoretically exact value shown without tolerances.

REF: Reference Dimension, usually without tolerance, for information purposes only.

**Footprint Outlines and Dimensions**

**56-Lead Very Thin Plastic Quad Flat, No Lead Package (VU) - 7x7 mm Body [VQFN]**

**Note:** For the most current package drawings, please see the Microchip Packaging Specification located at <http://www.microchip.com/packaging>

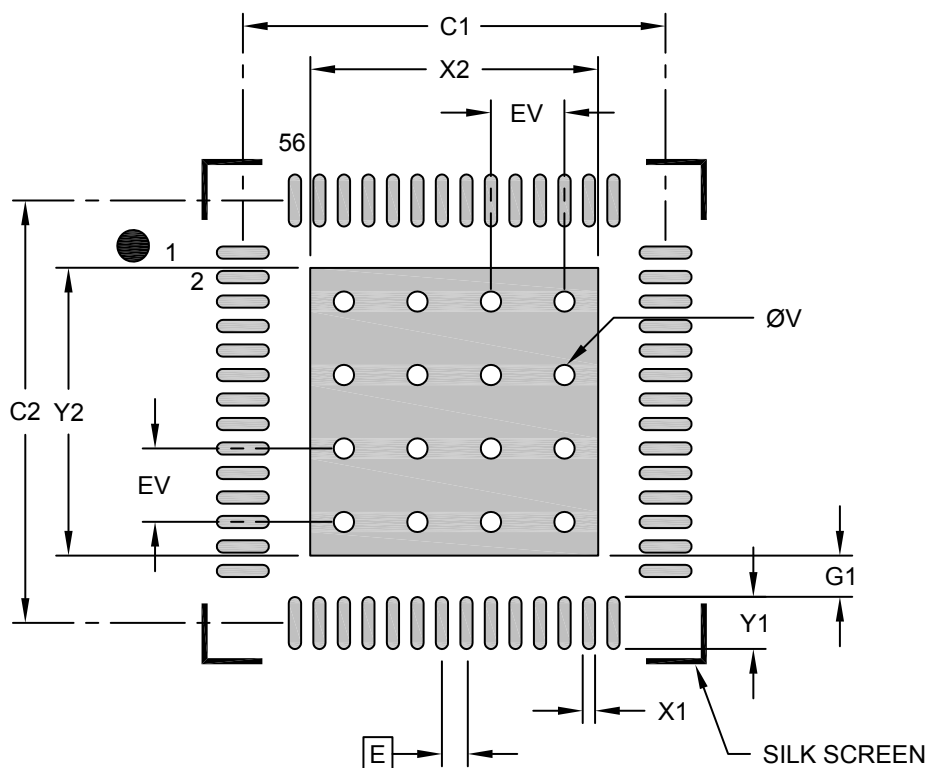

**RECOMMENDED LAND PATTERN**

Dimension	Units	MILLIMETERS		
		MIN	NOM	MAX
Contact Pitch	E	0.40 BSC		
Optional Center Pad Width	X2			4.70
Optional Center Pad Length	Y2			4.70
Contact Pad Spacing	C1		6.90	
Contact Pad Spacing	C2		6.90	
Contact Pad Width (X56)	X1			0.20
Contact Pad Length (X56)	Y1			0.85
Contact Pad to Center Pad (X56)	G1	0.20		
Thermal Via Diameter	V		0.33	
Thermal Via Pitch	EV		1.20	

**Notes:**

1. Dimensioning and tolerancing per ASME Y14.5M  
BSC: Basic Dimension. Theoretically exact value shown without tolerances.
2. For best soldering results, thermal vias, if used, should be filled or tented to avoid solder loss during reflow process



**Package Outlines and Dimensions**

**56-Lead Very Thin Plastic Quad Flat, No Lead Package (2G) - 7x7 mm Body [VQFN]**

**Note:** For the most current package drawings, please see the Microchip Packaging Specification located at <http://www.microchip.com/packaging>

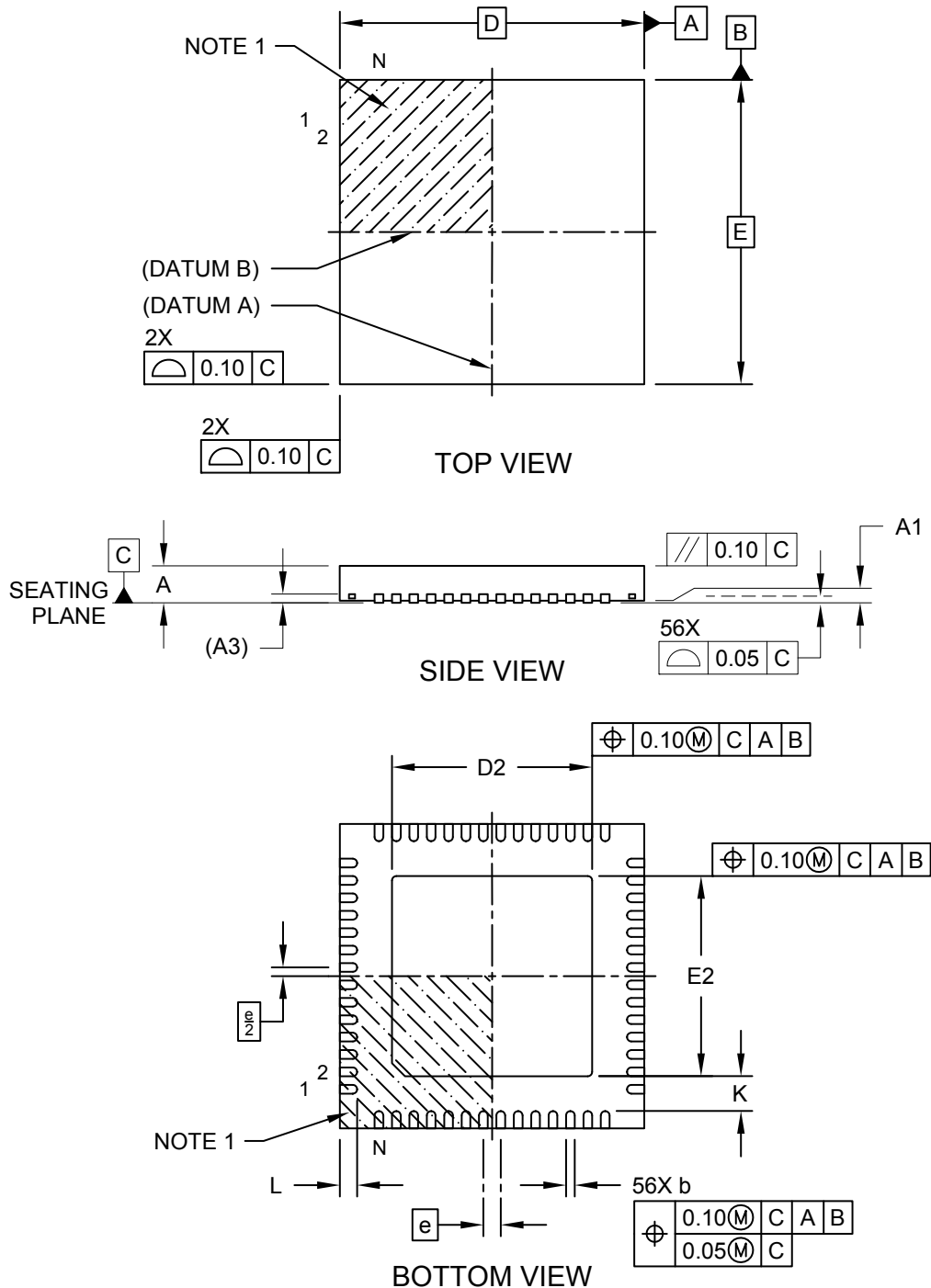

**Package Outlines and Dimensions**

**56-Lead Very Thin Plastic Quad Flat, No Lead Package (2G) - 7x7 mm Body [VQFN]**

**Note:** For the most current package drawings, please see the Microchip Packaging Specification located at <http://www.microchip.com/packaging>

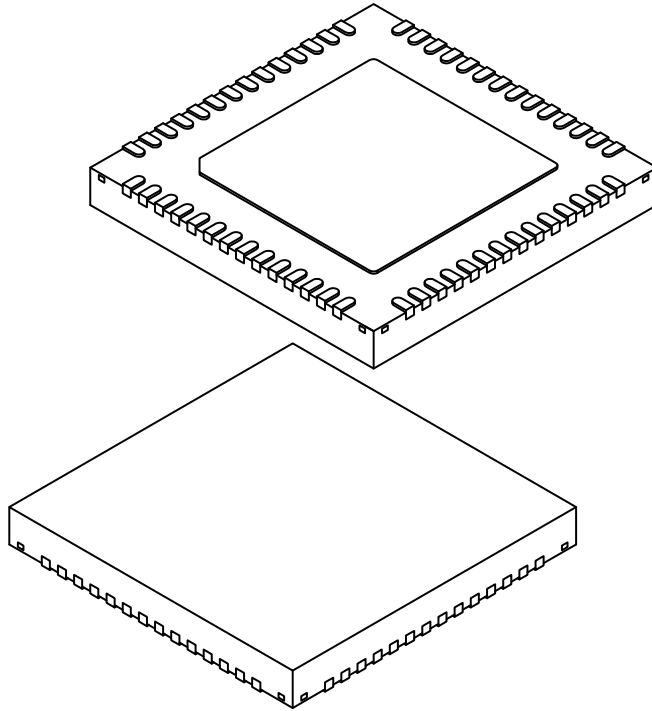

Dimension Limits		Units	MILLIMETERS		
			MIN	NOM	MAX
Number of Terminals	N		56		
Pitch	e		0.40 BSC		
Overall Height	A	0.80	0.85	0.90	
Standoff	A1	0.00	0.02	0.05	
Terminal Thickness	A3	0.20 REF			
Overall Length	D	7.00 BSC			
Exposed Pad Length	D2	4.50	4.60	4.70	
Overall Width	E	7.00 BSC			
Exposed Pad Width	E2	4.50	4.60	4.70	
Terminal Width	b	0.15	0.20	0.30	
Terminal Length	L	0.35	0.40	0.45	
Terminal-to-Exposed-Pad	K	0.70	-	-	

**Notes:**

1. Pin 1 visual index feature may vary, but must be located within the hatched area.
2. Package is saw singulated
3. Dimensioning and tolerancing per ASME Y14.5M

BSC: Basic Dimension. Theoretically exact value shown without tolerances.

REF: Reference Dimension, usually without tolerance, for information purposes only.

---



---

## Footprint Outlines and Dimensions

---



---

### 56-Lead Very Thin Plastic Quad Flat, No Lead Package (2G) - 7x7 mm Body [VQFN]

**Note:** For the most current package drawings, please see the Microchip Packaging Specification located at <http://www.microchip.com/packaging>

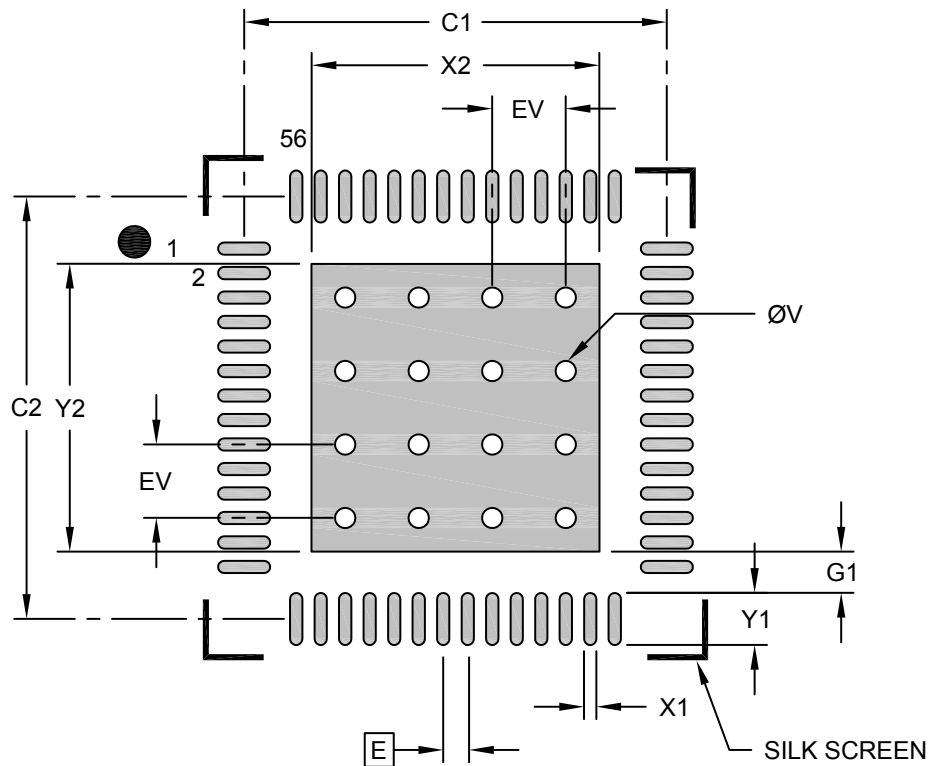

#### RECOMMENDED LAND PATTERN

Dimension Limits	Units	MILLIMETERS		
		MIN	NOM	MAX
Contact Pitch	E	0.40 BSC		
Optional Center Pad Width	X2			4.70
Optional Center Pad Length	Y2			4.70
Contact Pad Spacing	C1		6.90	
Contact Pad Spacing	C2		6.90	
Contact Pad Width (X56)	X1			0.20
Contact Pad Length (X56)	Y1			0.85
Contact Pad to Center Pad (X56)	G1	0.20		
Thermal Via Diameter	V		0.33	
Thermal Via Pitch	EV		1.20	

**Notes:**

1. Dimensioning and tolerancing per ASME Y14.5M  
     BSC: Basic Dimension. Theoretically exact value shown without tolerances.
2. For best soldering results, thermal vias, if used, should be filled or tented to avoid solder loss during reflow process

**Package Outlines and Dimensions**

**56-Lead Very Thin Plastic Quad Flat, No Lead Package (UZ) - 7x7 mm Body [VQFN]  
Saw Singulated; ISSC Legacy Package**

**Note:** For the most current package drawings, please see the Microchip Packaging Specification located at <http://www.microchip.com/packaging>

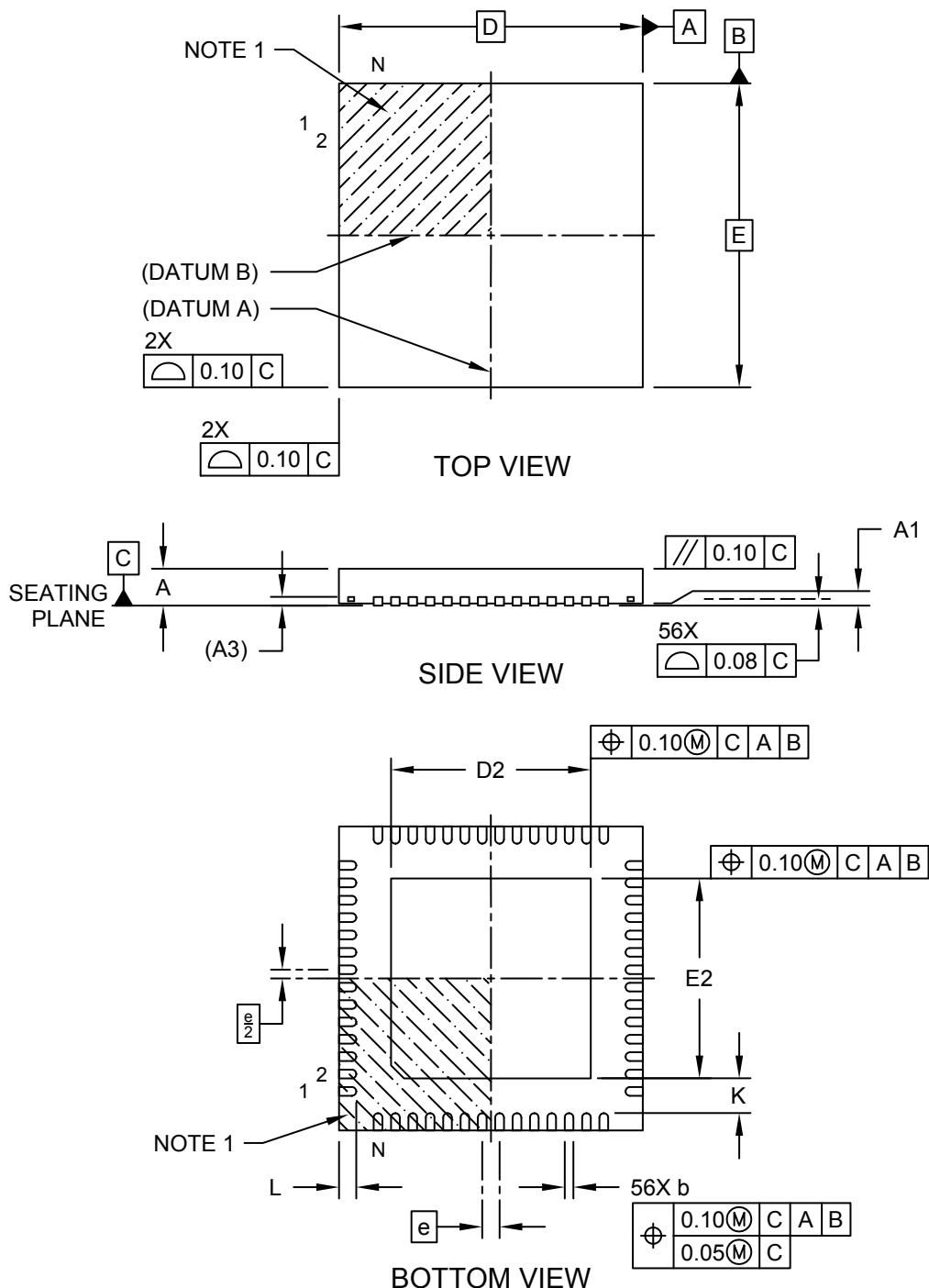

---



---

## Package Outlines and Dimensions

---



---

### 56-Lead Very Thin Plastic Quad Flat, No Lead Package (UZ) - 7x7 mm Body [VQFN] Saw Singulated; ISSC Legacy Package

**Note:** For the most current package drawings, please see the Microchip Packaging Specification located at <http://www.microchip.com/packaging>

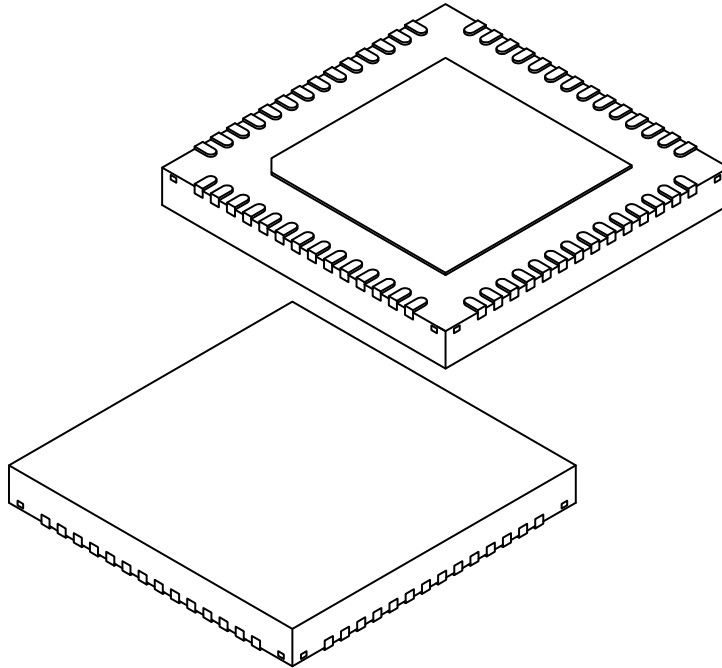

Dimension Limits		MILLIMETERS		
		MIN	NOM	MAX
Number of Terminals	N	56		
Pitch	e	0.40 BSC		
Overall Height	A	0.8	0.85	0.90
Standoff	A1	0.00	0.02	0.05
Terminal Thickness	A3	0.203 REF		
Overall Length	D	7.00 BSC		
Exposed Pad Length	D2	4.50	4.60	4.70
Overall Width	E	7.00 BSC		
Exposed Pad Width	E2	4.50	4.60	4.70
Terminal Width	b	0.15	0.20	0.25
Terminal Length	L	0.35	0.40	0.45
Terminal-to-Exposed-Pad	K	0.20	-	-

**Notes:**

1. Pin 1 visual index feature may vary, but must be located within the hatched area.
2. Package is saw singulated
3. Dimensioning and tolerancing per ASME Y14.5M

BSC: Basic Dimension. Theoretically exact value shown without tolerances.

REF: Reference Dimension, usually without tolerance, for information purposes only.

**Footprint Outlines and Dimensions**

**56-Lead Very Thin Plastic Quad Flat, No Lead Package (UZ) - 7x7 mm Body [VQFN]  
Saw Singulated; ISSC Legacy Package**

**Note:** For the most current package drawings, please see the Microchip Packaging Specification located at <http://www.microchip.com/packaging>

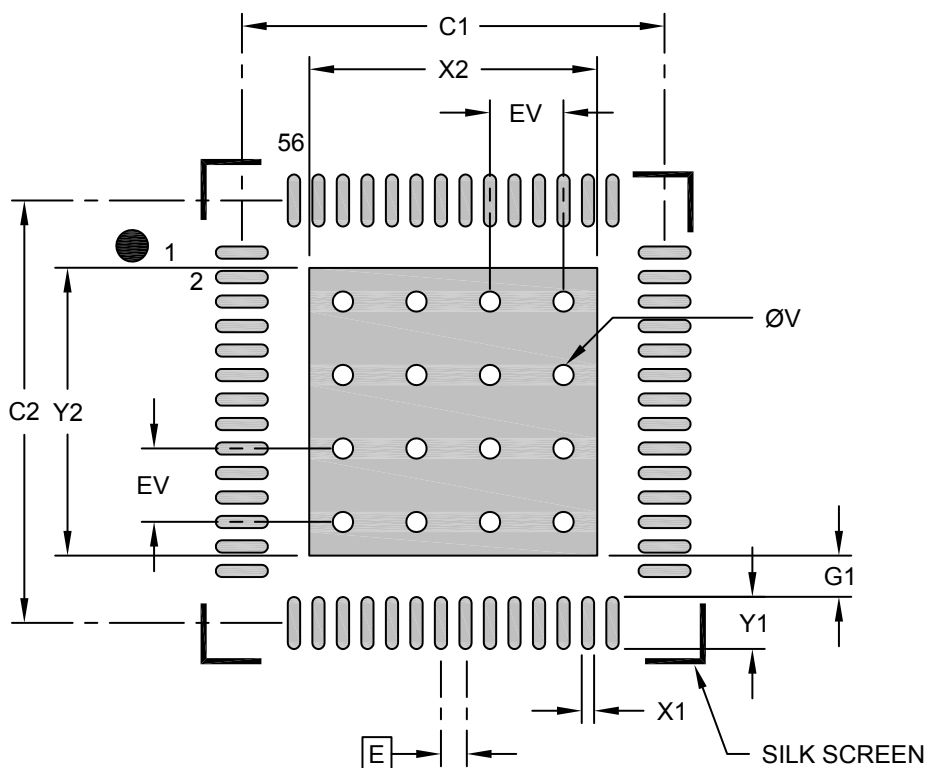

**RECOMMENDED LAND PATTERN**

Dimension Limits	Units	MILLIMETERS		
		MIN	NOM	MAX
Contact Pitch	E	0.40 BSC		
Optional Center Pad Width	X2			4.70
Optional Center Pad Length	Y2			4.70
Contact Pad Spacing	C1		6.90	
Contact Pad Spacing	C2		6.90	
Contact Pad Width (X56)	X1			0.20
Contact Pad Length (X56)	Y1			0.85
Contact Pad to Center Pad (X56)	G1	0.20		
Thermal Via Diameter	V		0.33	
Thermal Via Pitch	EV		1.20	

**Notes:**

1. Dimensioning and tolerancing per ASME Y14.5M  
BSC: Basic Dimension. Theoretically exact value shown without tolerances.
2. For best soldering results, thermal vias, if used, should be filled or tented to avoid solder loss during reflow process

**Package Outlines and Dimensions**

**56-Lead Very Thin Plastic Quad Flat, No Lead Package (VW) - 8x8 mm Body [VQFN]  
Saw Singulated; ISSC Legacy Package**

**Note:** For the most current package drawings, please see the Microchip Packaging Specification located at <http://www.microchip.com/packaging>

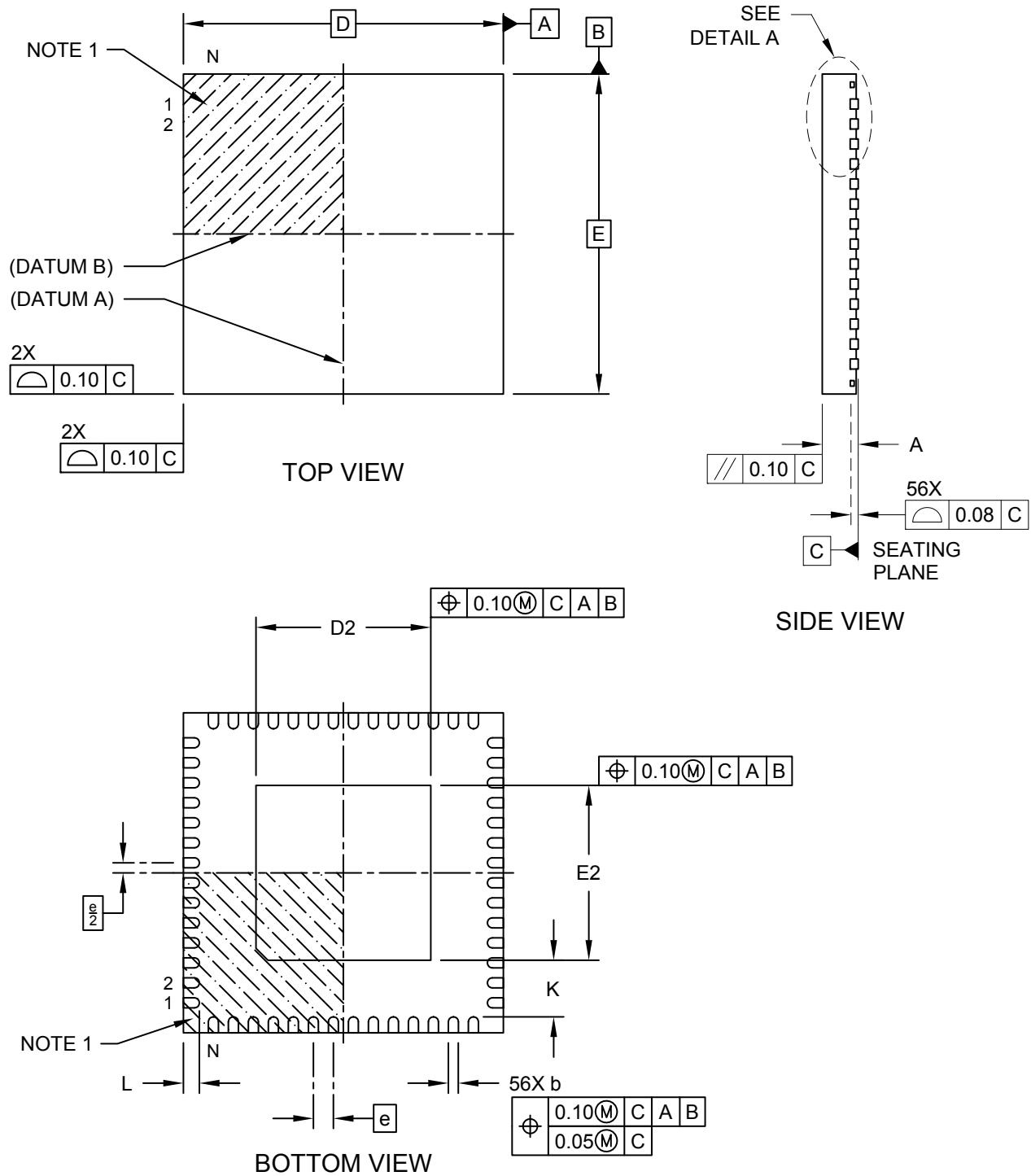

**Package Outlines and Dimensions**

**56-Lead Very Thin Plastic Quad Flat, No Lead Package (VW) - 8x8 mm Body [VQFN]  
Saw Singulated; ISSC Legacy Package**

**Note:** For the most current package drawings, please see the Microchip Packaging Specification located at <http://www.microchip.com/packaging>

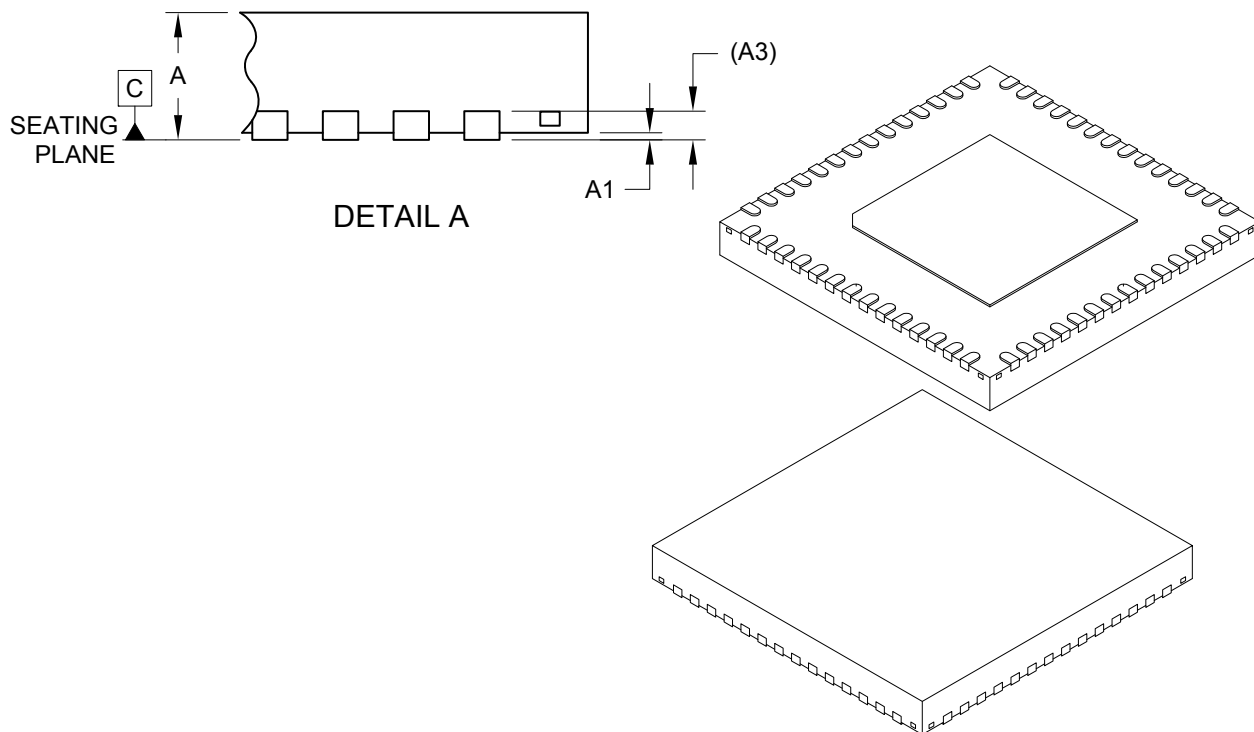

		Units	MILLIMETERS		
Dimension Limits			MIN	NOM	MAX
Number of Terminals	N		56		
Pitch	e		0.50 BSC		
Overall Height	A	0.80	0.85	0.90	
Standoff	A1	0.00	0.02	0.05	
Terminal Thickness	A3	0.203 REF			
Overall Length	D	8.00 BSC			
Exposed Pad Length	D2	4.27	4.37	4.47	
Overall Width	E	8.00 BSC			
Exposed Pad Width	E2	4.27	4.37	4.47	
Terminal Width	b	0.20	0.25	0.30	
Terminal Length	L	0.35	0.40	0.45	
Terminal-to-Exposed-Pad	K	0.20	-	-	

**Notes:**

1. Pin 1 visual index feature may vary, but must be located within the hatched area.
2. Package is saw singulated
3. Dimensioning and tolerancing per ASME Y14.5M

BSC: Basic Dimension. Theoretically exact value shown without tolerances.

REF: Reference Dimension, usually without tolerance, for information purposes only.



---



---

## Footprint Outlines and Dimensions

---



---

### 56-Lead Very Thin Plastic Quad Flat, No Lead Package (VW) - 8x8 mm Body [VQFN] Saw Singulated; ISSC Legacy Package

**Note:** For the most current package drawings, please see the Microchip Packaging Specification located at <http://www.microchip.com/packaging>

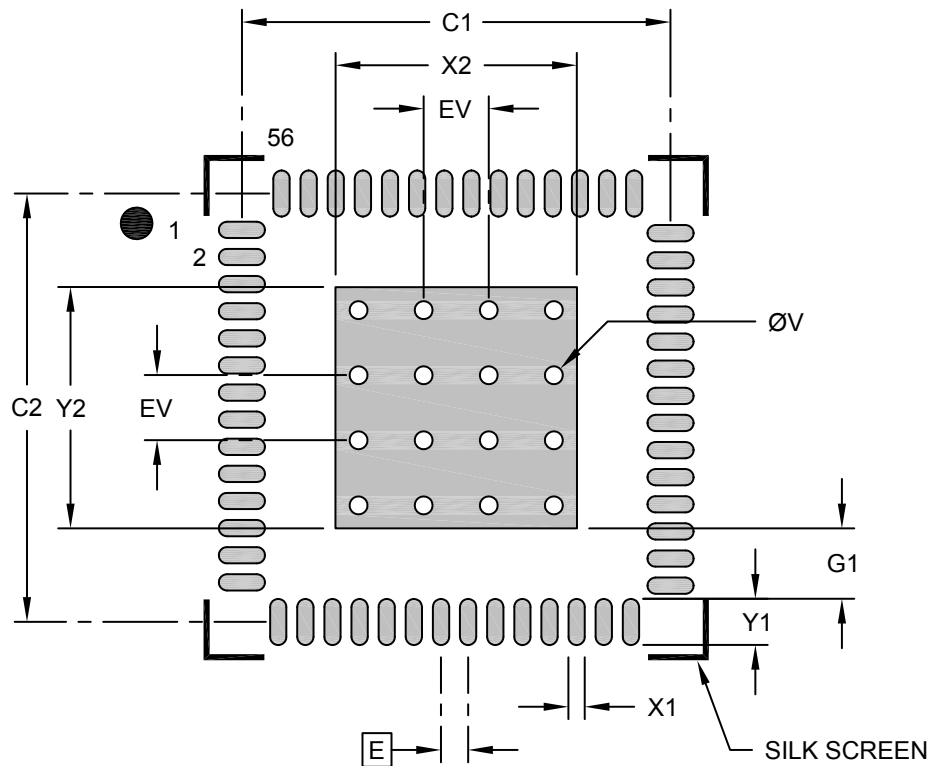

#### RECOMMENDED LAND PATTERN

Dimension Limits	Units	MILLIMETERS		
		MIN	NOM	MAX
Contact Pitch	E	0.50 BSC		
Optional Center Pad Width	X2			4.45
Optional Center Pad Length	Y2			4.45
Contact Pad Spacing	C1		7.90	
Contact Pad Spacing	C2		7.90	
Contact Pad Width (X56)	X1			0.30
Contact Pad Length (X56)	Y1			0.85
Contact Pad to Center Pad (X56)	G1	0.20		
Thermal Via Diameter	V		0.33	
Thermal Via Pitch	EV		1.20	

**Notes:**

1. Dimensioning and tolerancing per ASME Y14.5M  
BSC: Basic Dimension. Theoretically exact value shown without tolerances.
2. For best soldering results, thermal vias, if used, should be filled or tented to avoid solder loss during reflow process

**Package Outlines and Dimensions**

**56L Very Thin Quad Flat, No Lead Package (P6) - 8x8 mm Body [VQFN]  
With 5.2x5.2 mm Exposed Pad; Punch Singulated**

**Note:** For the most current package drawings, please see the Microchip Packaging Specification located at <http://www.microchip.com/packaging>

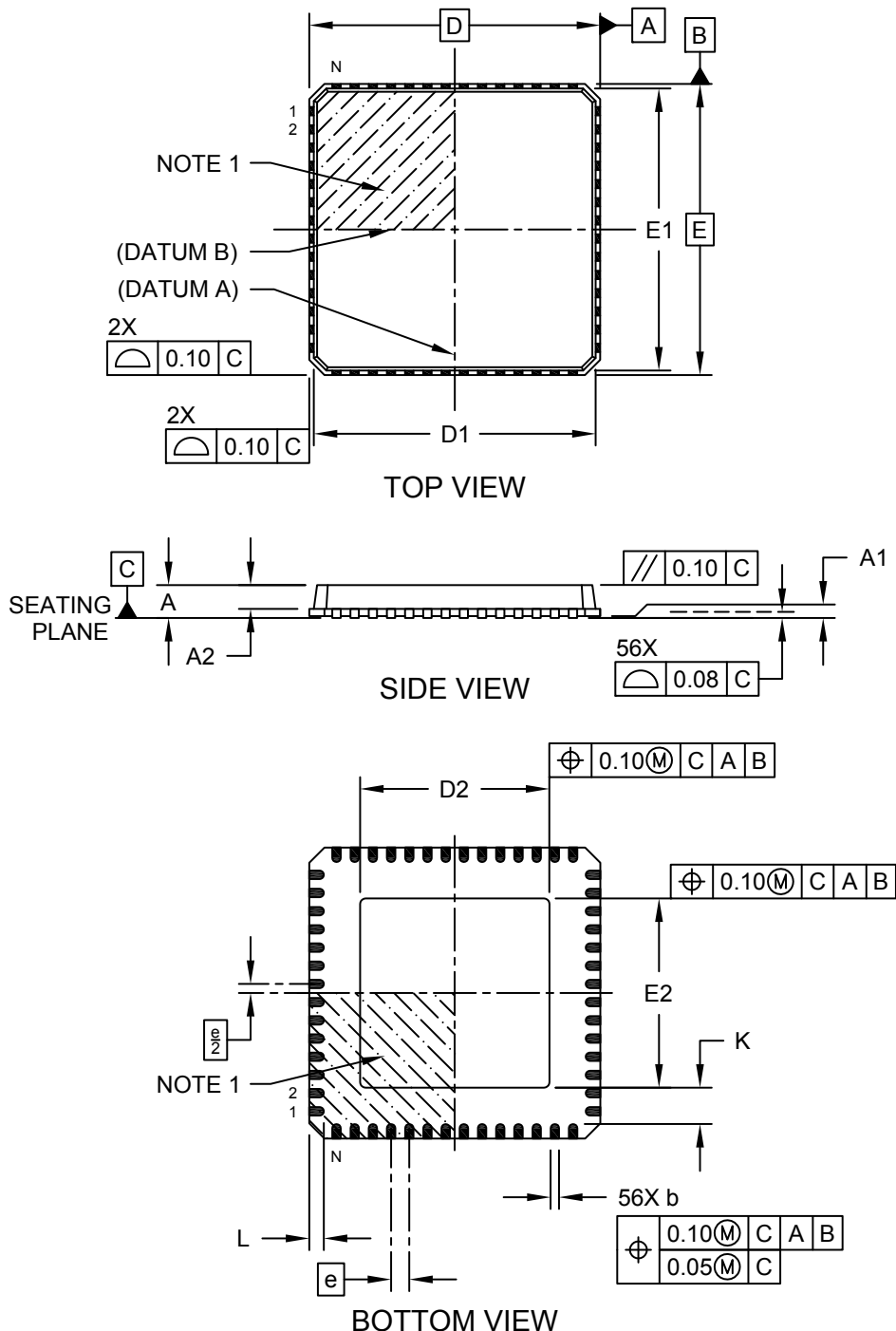

---



---

## Package Outlines and Dimensions

---



---

### 56L Very Thin Quad Flat, No Lead Package (P6) - 8x8 mm Body [VQFN] With 5.2x5.2 mm Exposed Pad; Punch Singulated

**Note:** For the most current package drawings, please see the Microchip Packaging Specification located at <http://www.microchip.com/packaging>

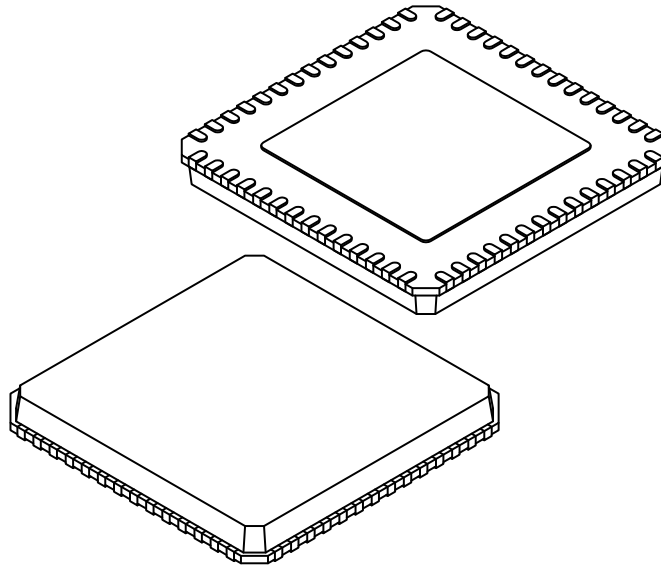

		Units	MILLIMETERS		
Dimension Limits			MIN	NOM	MAX
Number of Terminals	N		56		
Pitch	e		0.50 BSC		
Overall Height	A		0.80	0.85	0.90
Standoff	A1		0.00	0.02	0.05
Mold Cap Thickness	A2		-	-	0.70
Overall Length	D		8.00 BSC		
Molded Top Length	D1		7.65	7.75	7.85
Exposed Pad Length	D2		5.10	5.20	5.30
Overall Width	E		8.00 BSC		
Molded Top Width	E1		7.65	7.75	7.85
Exposed Pad Width	E2		5.10	5.20	5.30
Terminal Width	b		0.18	0.23	0.30
Terminal Length	L		0.30	0.40	0.50
Terminal-to-Exposed-Pad	K		0.70	-	-

**Notes:**

1. Pin 1 visual index feature may vary, but must be located within the hatched area.
2. Package is punch singulated
3. Dimensioning and tolerancing per ASME Y14.5M
  - BSC: Basic Dimension. Theoretically exact value shown without tolerances.
  - REF: Reference Dimension, usually without tolerance, for information purposes only.

**Footprint Outlines and Dimensions**

**56L Very Thin Quad Flat, No Lead Package (P6) - 8x8 mm Body [VQFN]  
With 5.2x5.2 mm Exposed Pad; Punch Singulated**

**Note:** For the most current package drawings, please see the Microchip Packaging Specification located at <http://www.microchip.com/packaging>

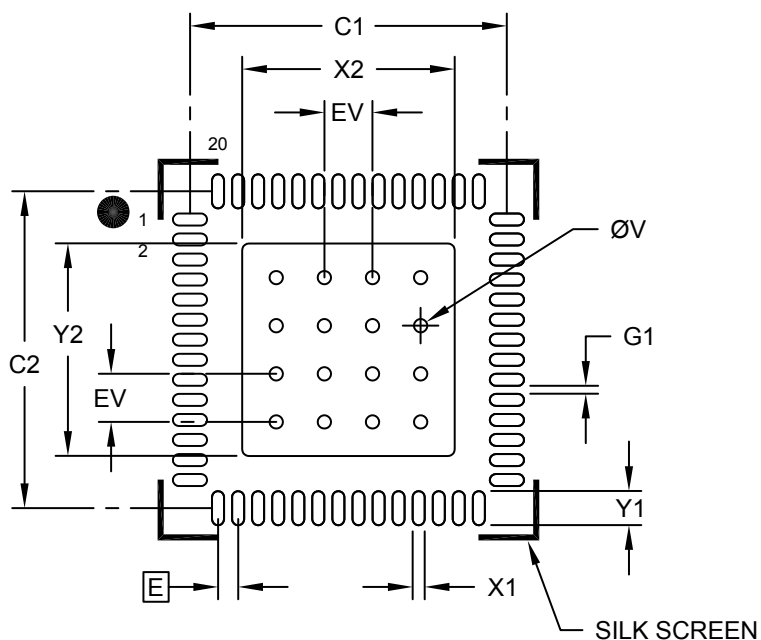

**RECOMMENDED LAND PATTERN**

Dimension Limits	Units	MILLIMETERS		
		MIN	NOM	MAX
Contact Pitch	E	0.50 BSC		
Optional Center Pad Width	X2			5.30
Optional Center Pad Length	Y2			5.30
Contact Pad Spacing	C1		7.90	
Contact Pad Spacing	C2		7.90	
Contact Pad Width (X56)	X1			0.30
Contact Pad Length (X56)	Y1			0.85
Contact Pad to Center Pad (X52)	G1	0.20		
Thermal Via Diameter	V		0.33	
Thermal Via Pitch	EV		1.20	

**Notes:**

- Dimensioning and tolerancing per ASME Y14.5M  
BSC: Basic Dimension. Theoretically exact value shown without tolerances.
- For best soldering results, thermal vias, if used, should be filled or tented to avoid solder loss during reflow process

**Package Outlines and Dimensions**

**56L Very Thin Quad Flat, No Lead Package (RT) - 8x8 mm Body [VQFN]  
With 5.9x5.9 mm Exposed Pad; Punch Singulated**

**Note:** For the most current package drawings, please see the Microchip Packaging Specification located at <http://www.microchip.com/packaging>

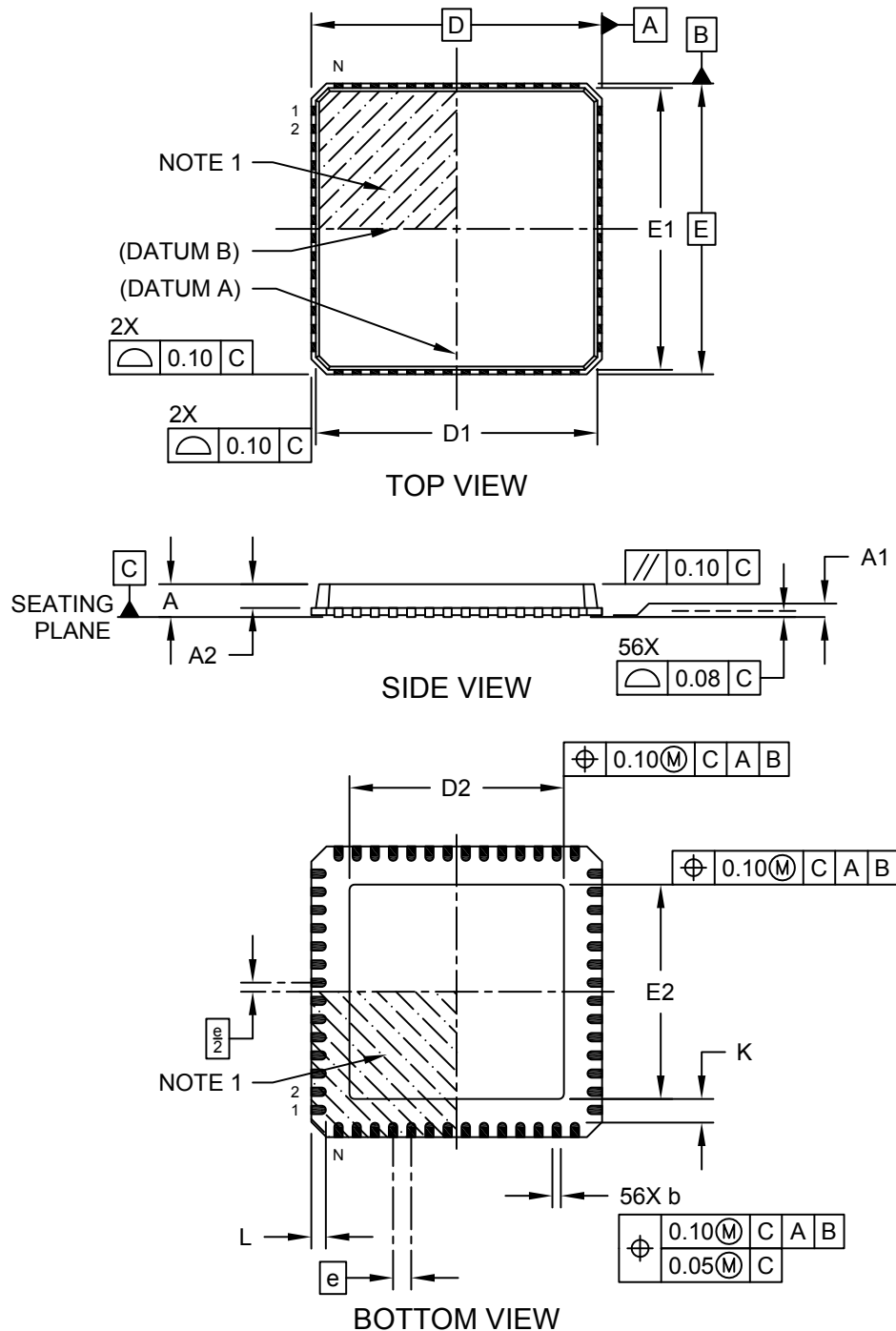

**Package Outlines and Dimensions**

**56L Very Thin Quad Flat, No Lead Package (RT) - 8x8 mm Body [VQFN]  
With 5.9x5.9 mm Exposed Pad; Punch Singulated**

**Note:** For the most current package drawings, please see the Microchip Packaging Specification located at <http://www.microchip.com/packaging>

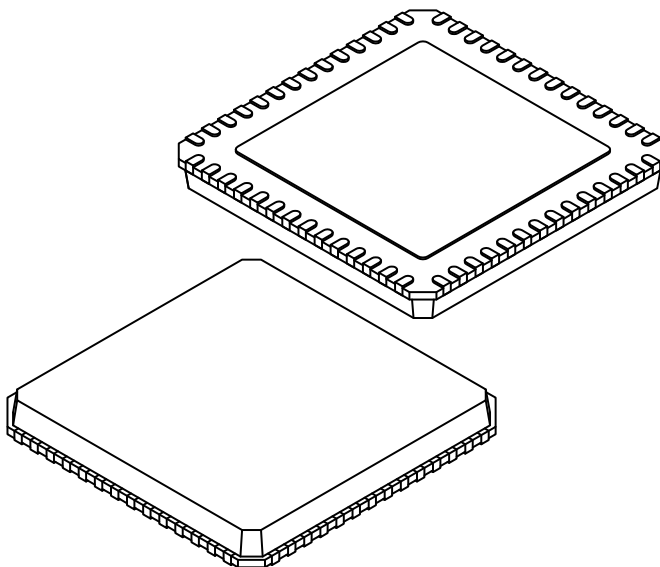

		Units	MILLIMETERS		
Dimension Limits			MIN	NOM	MAX
Number of Terminals	N		56		
Pitch	e		0.50 BSC		
Overall Height	A	0.70	0.85	1.00	
Standoff	A1	0.00	0.02	0.05	
Mold Cap Thickness	A2	-	-	0.90	
Overall Length	D		8.00 BSC		
Molded Top Length	D1	7.65	7.75	7.85	
Exposed Pad Length	D2	5.80	5.90	6.00	
Overall Width	E		8.00 BSC		
Molded Top Width	E1	7.65	7.75	7.85	
Exposed Pad Width	E2	5.80	5.90	6.00	
Terminal Width	b	0.18	0.23	0.30	
Terminal Length	L	0.30	0.40	0.50	
Terminal-to-Exposed-Pad	K	0.20	-	-	

**Notes:**

1. Pin 1 visual index feature may vary, but must be located within the hatched area.
2. Package is punch singulated
3. Dimensioning and tolerancing per ASME Y14.5M

BSC: Basic Dimension. Theoretically exact value shown without tolerances.

REF: Reference Dimension, usually without tolerance, for information purposes only.

---



---

## Footprint Outlines and Dimensions

---



---

### 56L Very Thin Quad Flat, No Lead Package (RT) - 8x8 mm Body [VQFN] With 5.9x5.9 mm Exposed Pad; Punch Singulated

**Note:** For the most current package drawings, please see the Microchip Packaging Specification located at <http://www.microchip.com/packaging>

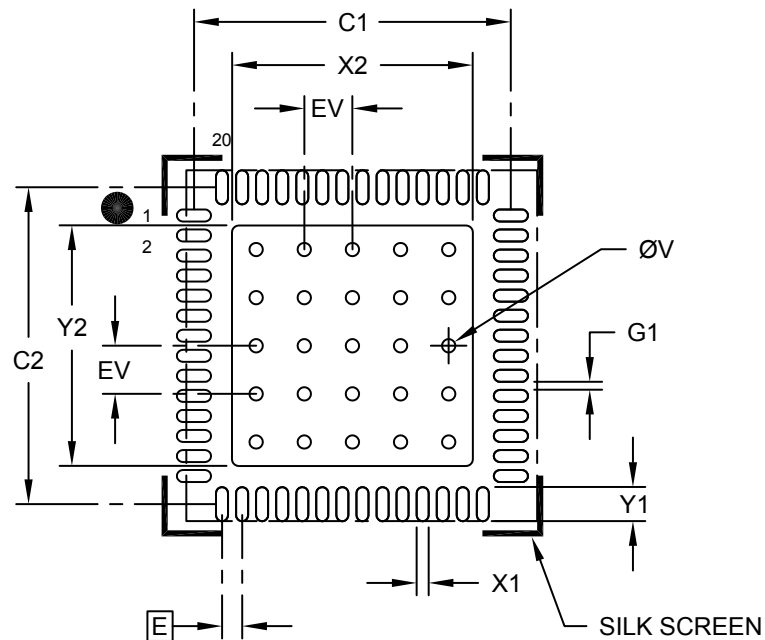

### RECOMMENDED LAND PATTERN

Dimension Limits	Units	MILLIMETERS		
		MIN	NOM	MAX
Contact Pitch	E	0.50 BSC		
Optional Center Pad Width	X2			5.90
Optional Center Pad Length	Y2			5.90
Contact Pad Spacing	C1		7.90	
Contact Pad Spacing	C2		7.90	
Contact Pad Width (X56)	X1			0.28
Contact Pad Length (X56)	Y1			0.69
Contact Pad to Center Pad (X52)	G1	0.20		
Thermal Via Diameter	V		0.33	
Thermal Via Pitch	EV		1.20	

**Notes:**

- Dimensioning and tolerancing per ASME Y14.5M  
BSC: Basic Dimension. Theoretically exact value shown without tolerances.
- For best soldering results, thermal vias, if used, should be filled or tented to avoid solder loss during reflow process

**Package Outlines and Dimensions**

**64-Lead Very Thin Plastic Quad Flat, No Lead Package (3S) - 9x9 mm Body [VQFN]  
With 0.95 mm Package Height**

**Note:** For the most current package drawings, please see the Microchip Packaging Specification located at <http://www.microchip.com/packaging>

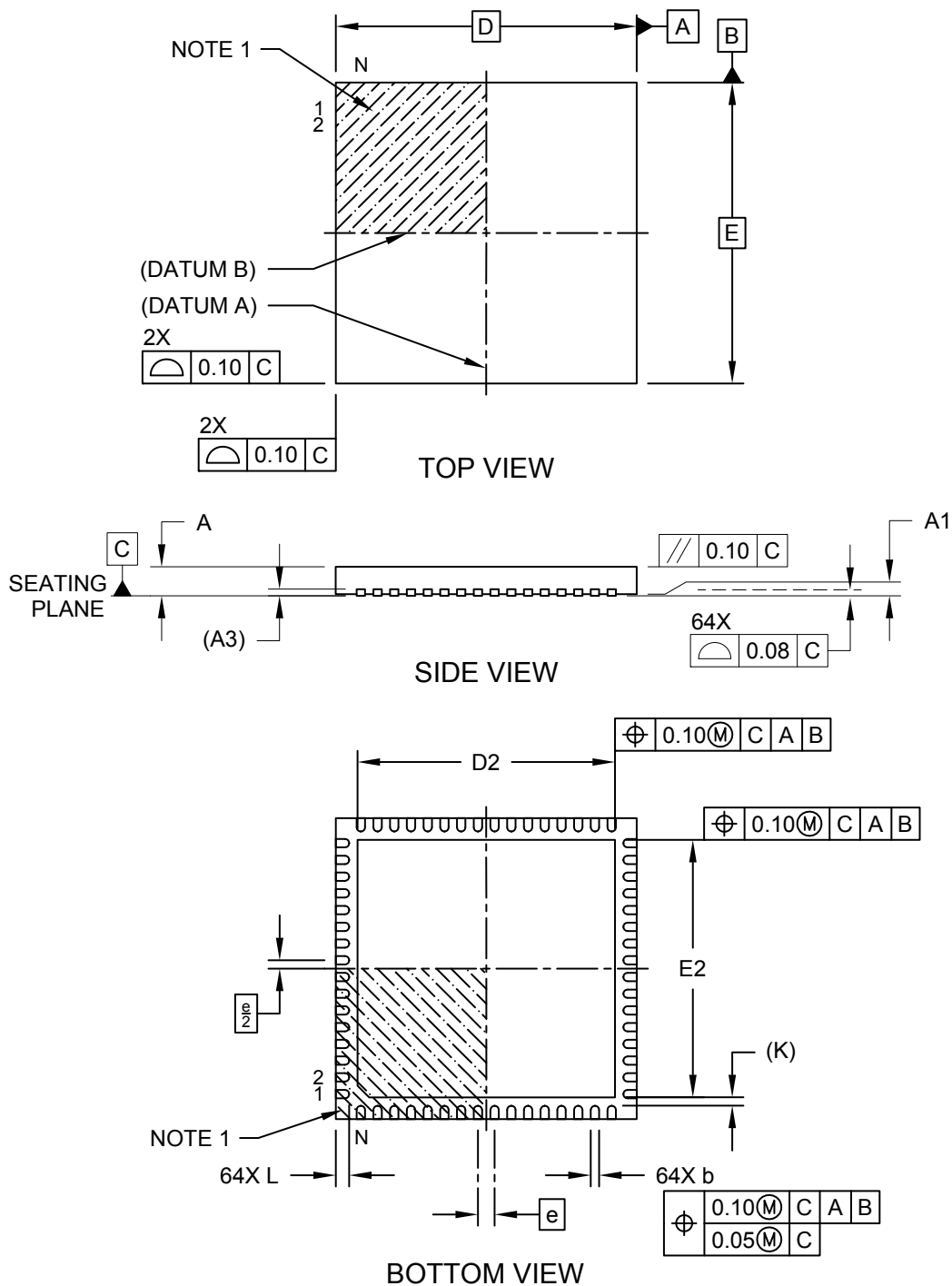



---



---

## Package Outlines and Dimensions

---



---

### 64-Lead Very Thin Plastic Quad Flat, No Lead Package (3S) - 9x9 mm Body [VQFN] With 0.95 mm Package Height

**Note:** For the most current package drawings, please see the Microchip Packaging Specification located at <http://www.microchip.com/packaging>

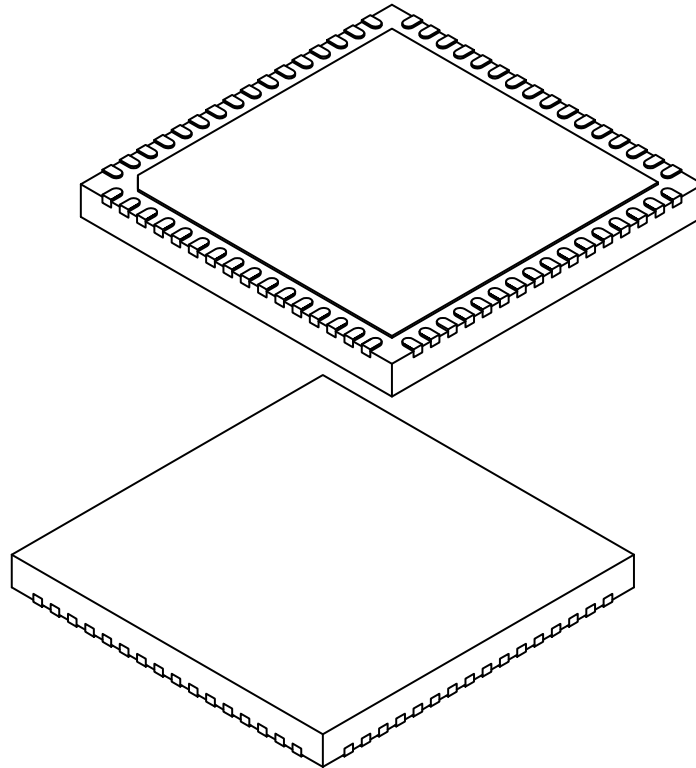

		Units	MILLIMETERS		
Dimension Limits			MIN	NOM	MAX
Number of Terminals	N		64		
Pitch	e		0.50 BSC		
Overall Height	A	0.80	0.87	0.95	
Standoff	A1	0.00	0.02	0.05	
Terminal Thickness	A3	0.20 REF			
Overall Length	D	9.00 BSC			
Exposed Pad Length	D2	7.60	7.70	7.80	
Overall Width	E	9.00 BSC			
Exposed Pad Width	E2	7.60	7.70	7.80	
Terminal Width	b	0.20	0.25	0.30	
Terminal Length	L	0.30	0.40	0.50	
Terminal-to-Exposed-Pad	K	0.25 REF			

**Notes:**

1. Pin 1 visual index feature may vary, but must be located within the hatched area.
2. Package is saw singulated
3. Dimensioning and tolerancing per ASME Y14.5M

BSC: Basic Dimension. Theoretically exact value shown without tolerances.

REF: Reference Dimension, usually without tolerance, for information purposes only.

**Footprint Outlines and Dimensions**

**64-Lead Very Thin Plastic Quad Flat, No Lead Package (3S) - 9x9 mm Body [VQFN]  
With 0.95 mm Package Height**

**Note:** For the most current package drawings, please see the Microchip Packaging Specification located at <http://www.microchip.com/packaging>

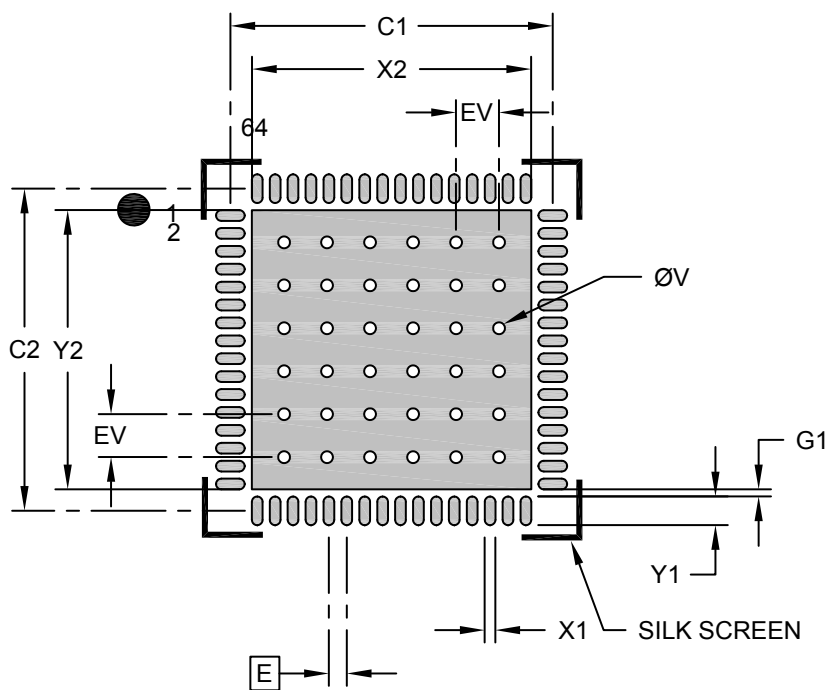

**RECOMMENDED LAND PATTERN**

Dimension Limits	Units	MILLIMETERS		
		MIN	NOM	MAX
Contact Pitch	E	0.50 BSC		
Optional Center Pad Width	X2			7.80
Optional Center Pad Length	Y2			7.80
Contact Pad Spacing	C1		9.00	
Contact Pad Spacing	C2		9.00	
Contact Pad Width (X64)	X1			0.30
Contact Pad Length (X64)	Y1			0.80
Contact Pad to Center Pad (X64)	G1	0.20		
Thermal Via Diameter	V		0.33	
Thermal Via Pitch	EV		1.20	

**Notes:**

1. Dimensioning and tolerancing per ASME Y14.5M  
BSC: Basic Dimension. Theoretically exact value shown without tolerances.
2. For best soldering results, thermal vias, if used, should be filled or tented to avoid solder loss during reflow process

**Package Outlines and Dimensions**

**64-Lead Very Thin Plastic Quad Flat No Lead Package (9JX) - 9x9 mm Body [VQFN]  
With 6x6 mm Exposed Pad**

**Note:** For the most current package drawings, please see the Microchip Packaging Specification located at <http://www.microchip.com/packaging>

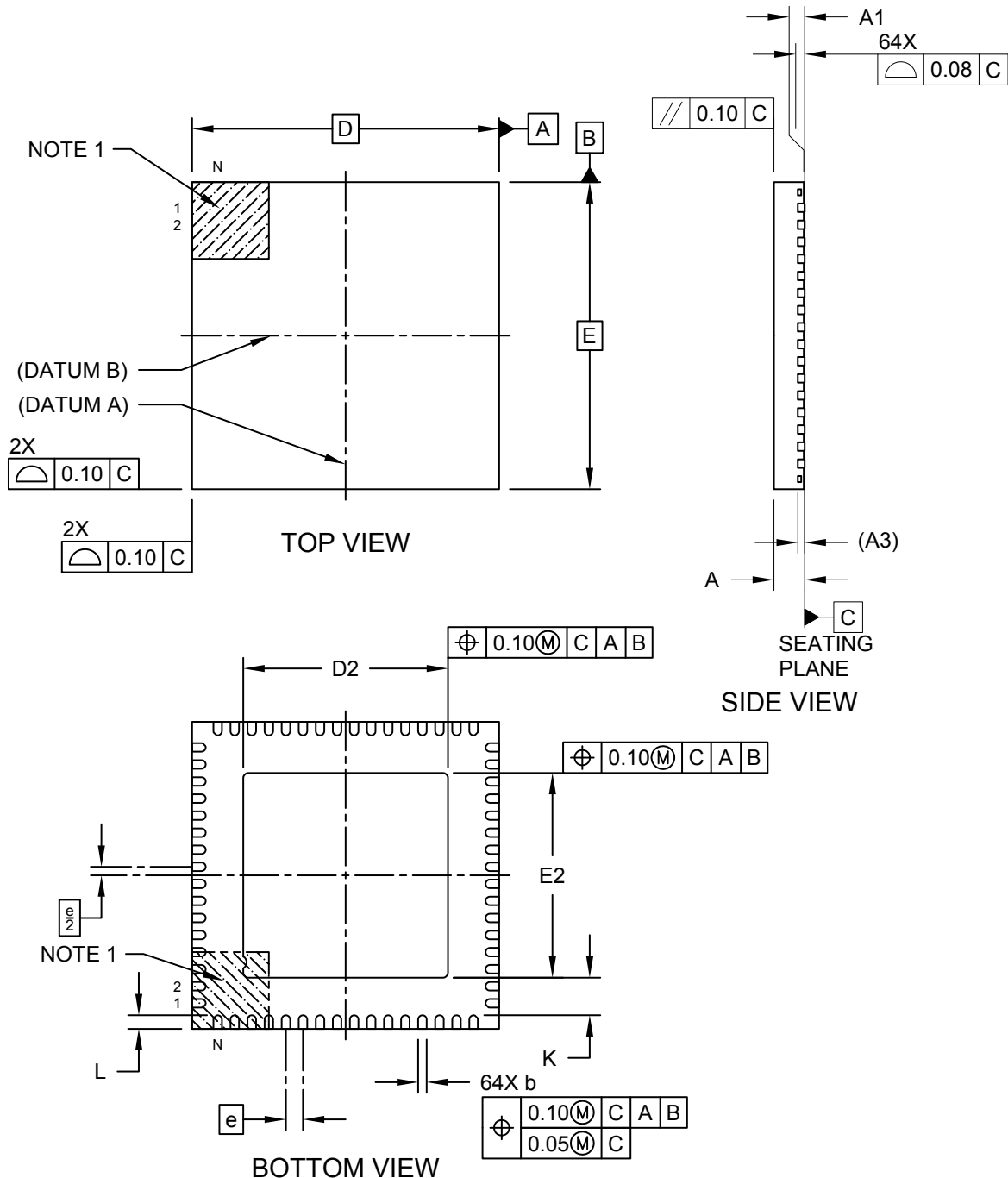

**Package Outlines and Dimensions**

**64-Lead Very Thin Plastic Quad Flat No Lead Package (9JX) - 9x9 mm Body [VQFN]  
With 6x6 mm Exposed Pad**

**Note:** For the most current package drawings, please see the Microchip Packaging Specification located at <http://www.microchip.com/packaging>

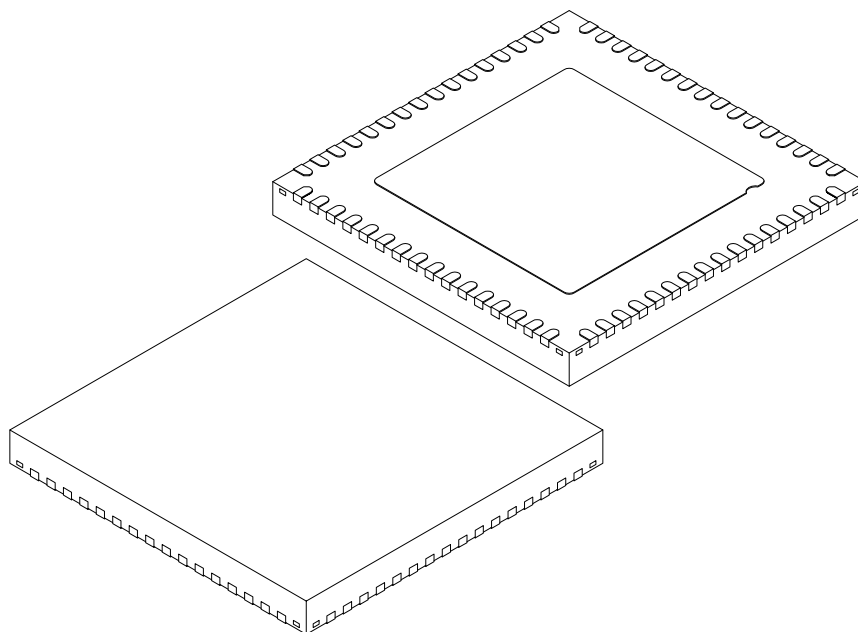

Dimension Limits	Units	MILLIMETERS		
		MIN	NOM	MAX
Number of Terminals	N	64		
Pitch	e	0.50 BSC		
Overall Height	A	0.80	0.85	0.90
Standoff	A1	0.00	0.02	0.05
Terminal Thickness	A3	0.20 REF		
Overall Length	D	9.00 BSC		
Exposed Pad Length	D2	5.90	6.00	6.10
Overall Width	E	9.00 BSC		
Exposed Pad Width	E2	5.90	6.00	6.10
Terminal Width	b	0.18	0.25	0.30
Terminal Length	L	0.35	0.40	0.45
Terminal-to-Exposed-Pad	K	-	1.10	-

Notes:

1. Pin 1 visual index feature may vary, but must be located within the hatched area.
2. Package is saw singulated
3. Dimensioning and tolerancing per ASME Y14.5M

BSC: Basic Dimension. Theoretically exact value shown without tolerances.

REF: Reference Dimension, usually without tolerance, for information purposes only.

---



---

## Footprint Outlines and Dimensions

---



---

### 64-Lead Very Thin Plastic Quad Flat No Lead Package (9JX) - 9x9 mm Body [VQFN] With 6x6 mm Exposed Pad

**Note:** For the most current package drawings, please see the Microchip Packaging Specification located at <http://www.microchip.com/packaging>

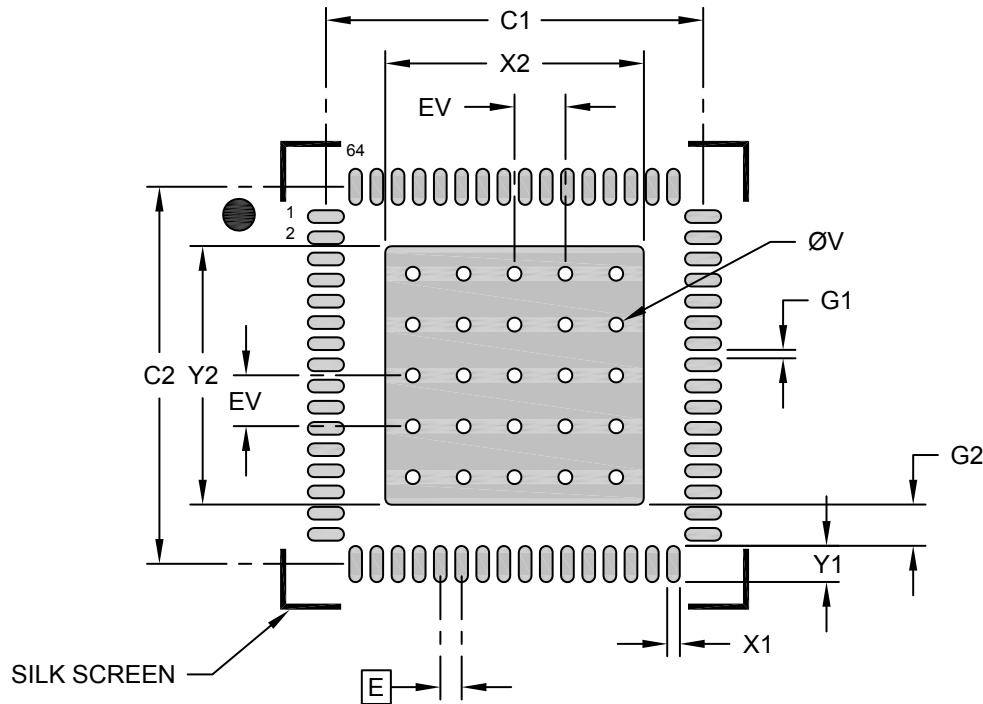

### RECOMMENDED LAND PATTERN

Dimension Limits	Units	MILLIMETERS		
		MIN	NOM	MAX
Contact Pitch	E	0.50 BSC		
Center Pad Width	X2			6.10
Center Pad Length	Y2			6.10
Contact Pad Spacing	C1		8.90	
Contact Pad Spacing	C2		8.90	
Contact Pad Width (X64)	X1			0.30
Contact Pad Length (X64)	Y1			0.85
Contact Pad to Contact Pad (X60)	G1	0.20		
Contact Pad to Center Pad (X64)	G2	0.20		
Thermal Via Diameter	V		0.33	
Thermal Via Pitch	EV		1.20	

**Notes:**

1. Dimensioning and tolerancing per ASME Y14.5M  
     BSC: Basic Dimension. Theoretically exact value shown without tolerances.
2. For best soldering results, thermal vias, if used, should be filled or tented to avoid solder loss during reflow process

**Package Outlines and Dimensions**

**64-Lead Very Thin Plastic Quad Flat, No Lead Package (RG) - 9x9 mm Body [VQFN]  
Punch Singulated**

**Note:** For the most current package drawings, please see the Microchip Packaging Specification located at <http://www.microchip.com/packaging>

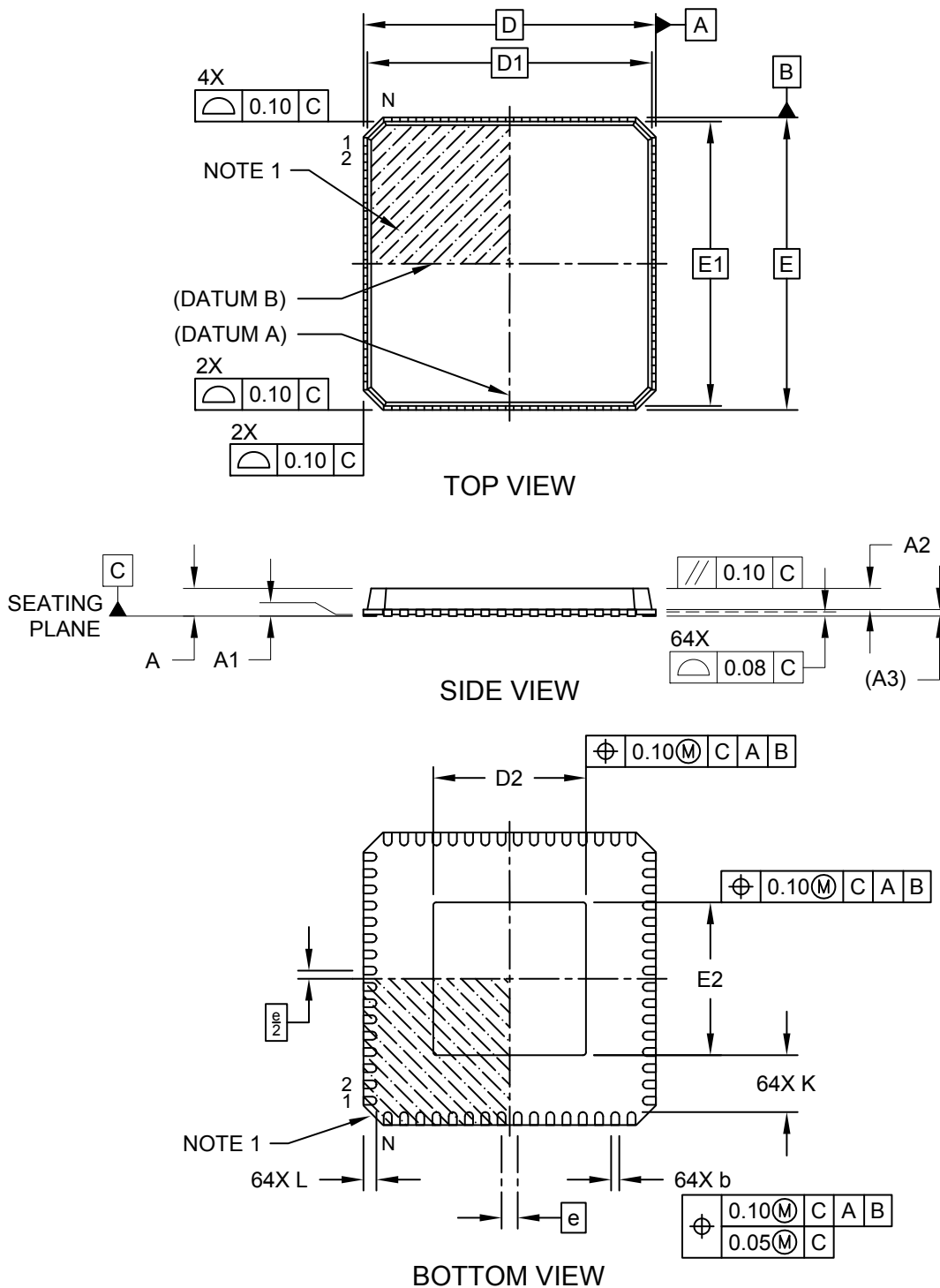

---



---

## Package Outlines and Dimensions

---



---

### 64-Lead Very Thin Plastic Quad Flat, No Lead Package (RG) - 9x9 mm Body [VQFN] With 4.7x4.7 mm Exposed Pad; Punch Singulated

**Note:** For the most current package drawings, please see the Microchip Packaging Specification located at <http://www.microchip.com/packaging>

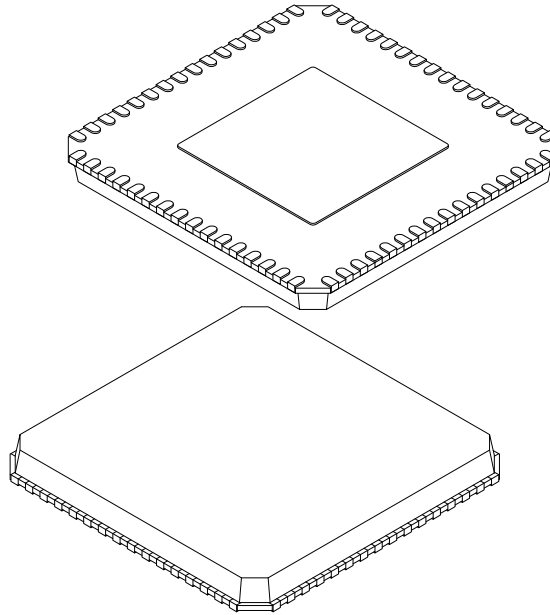

		MILLIMETERS		
Units				
Dimension Limits		MIN	NOM	MAX
Number of Terminals	N	64		
Pitch	e	0.50 BSC		
Overall Height	A	0.80	0.85	1.00
Standoff	A1	0.00	0.02	0.05
Mold Cap Thickness	A2	0.65	-	0.80
Terminal Thickness	(A3)	0.20 REF		
Overall Length	D	9.00 BSC		
Mold Top Length	D1	8.75 BSC		
Exposed Pad Length	D2	4.60	4.70	4.80
Overall Width	E	9.00 BSC		
Mold Top Width	E1	8.75 BSC		
Exposed Pad Width	E2	4.60	4.70	4.80
Terminal Width	b	0.18	0.25	0.30
Terminal Length	L	0.30	0.40	0.50
Terminal-to-Exposed-Pad	K	1.55	-	-

**Notes:**

1. Pin 1 visual index feature may vary, but must be located within the hatched area.
2. Package is saw singulated
3. Dimensioning and tolerancing per ASME Y14.5M

BSC: Basic Dimension. Theoretically exact value shown without tolerances.

REF: Reference Dimension, usually without tolerance, for information purposes only.

**Package Outlines and Dimensions**

**64-Lead Very Thin Plastic Quad Flat, No Lead Package (RG) - 9x9 mm Body [VQFN]  
With 6.0x6.0 mm Exposed Pad; Punch Singulated**

**Note:** For the most current package drawings, please see the Microchip Packaging Specification located at <http://www.microchip.com/packaging>

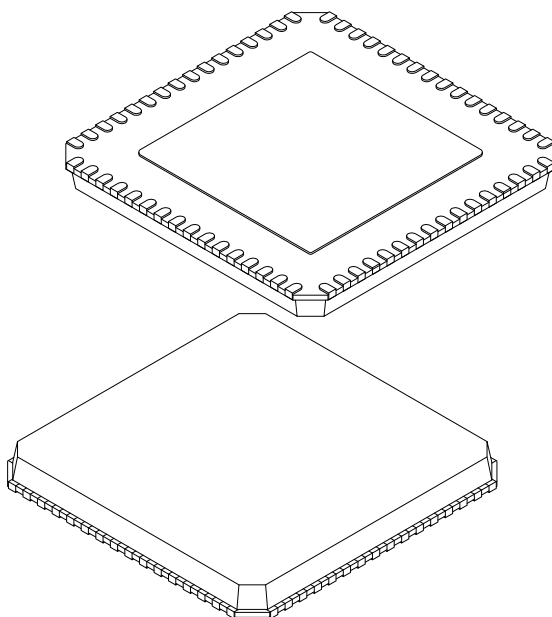

		MILLIMETERS		
Units		MIN	NOM	MAX
Dimension Limits				
Number of Terminals	N	64		
Pitch	e	0.50 BSC		
Overall Height	A	0.80	0.85	1.00
Standoff	A1	0.00	0.02	0.05
Mold Cap Thickness	A2	0.65	-	0.80
Terminal Thickness	(A3)	0.20 REF		
Overall Length	D	9.00 BSC		
Mold Top Length	D1	8.75 BSC		
Exposed Pad Length	D2	5.90	6.00	6.10
Overall Width	E	9.00 BSC		
Mold Top Width	E1	8.75 BSC		
Exposed Pad Width	E2	5.90	6.00	6.10
Terminal Width	b	0.18	0.25	0.30
Terminal Length	L	0.30	0.40	0.50
Terminal-to-Exposed-Pad	K	0.90	-	-

Notes:

- Pin 1 visual index feature may vary, but must be located within the hatched area.
- Package is saw singulated
- Dimensioning and tolerancing per ASME Y14.5M

BSC: Basic Dimension. Theoretically exact value shown without tolerances.

REF: Reference Dimension, usually without tolerance, for information purposes only.



---



---

## Package Outlines and Dimensions

---



---

### 64-Lead Very Thin Plastic Quad Flat, No Lead Package (RG) - 9x9 mm Body [VQFN] With 7.3x7.3 mm Exposed Pad; Punch Singulated

**Note:** For the most current package drawings, please see the Microchip Packaging Specification located at <http://www.microchip.com/packaging>

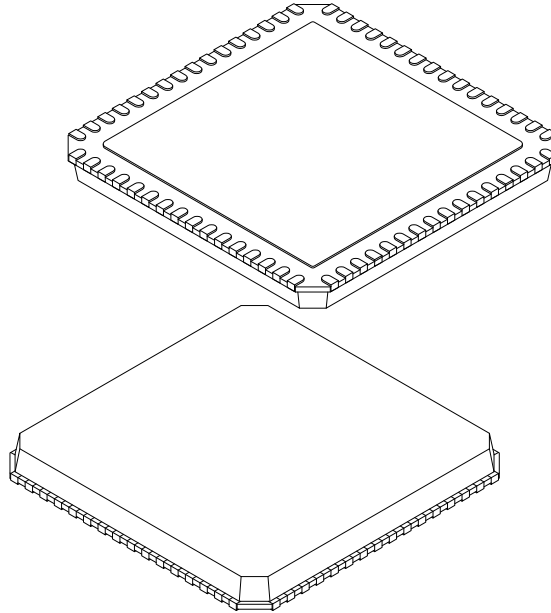

		MILLIMETERS		
		MIN	NOM	MAX
Units				
Dimension Limits				
Number of Terminals	N	64		
Pitch	e	0.50 BSC		
Overall Height	A	0.80	0.85	1.00
Standoff	A1	0.00	0.02	0.05
Mold Cap Thickness	A2	0.65	-	0.80
Terminal Thickness	(A3)	0.20 REF		
Overall Length	D	9.00 BSC		
Mold Top Length	D1	8.75 BSC		
Exposed Pad Length	D2	7.20	7.30	7.40
Overall Width	E	9.00 BSC		
Mold Top Width	E1	8.75 BSC		
Exposed Pad Width	E2	7.20	7.30	7.40
Terminal Width	b	0.18	0.25	0.30
Terminal Length	L	0.30	0.40	0.50
Terminal-to-Exposed-Pad	K	1.55	-	-

**Notes:**

1. Pin 1 visual index feature may vary, but must be located within the hatched area.
2. Package is saw singulated
3. Dimensioning and tolerancing per ASME Y14.5M

BSC: Basic Dimension. Theoretically exact value shown without tolerances.

REF: Reference Dimension, usually without tolerance, for information purposes only.

**Package Outlines and Dimensions**

**64-Lead Very Thin Plastic Quad Flat, No Lead Package (MR) – 9x9x0.9 mm Body [VQFN]  
With 7.15 x 7.15 Exposed Pad [Also called QFN]**

**Note:** For the most current package drawings, please see the Microchip Packaging Specification located at <http://www.microchip.com/packaging>

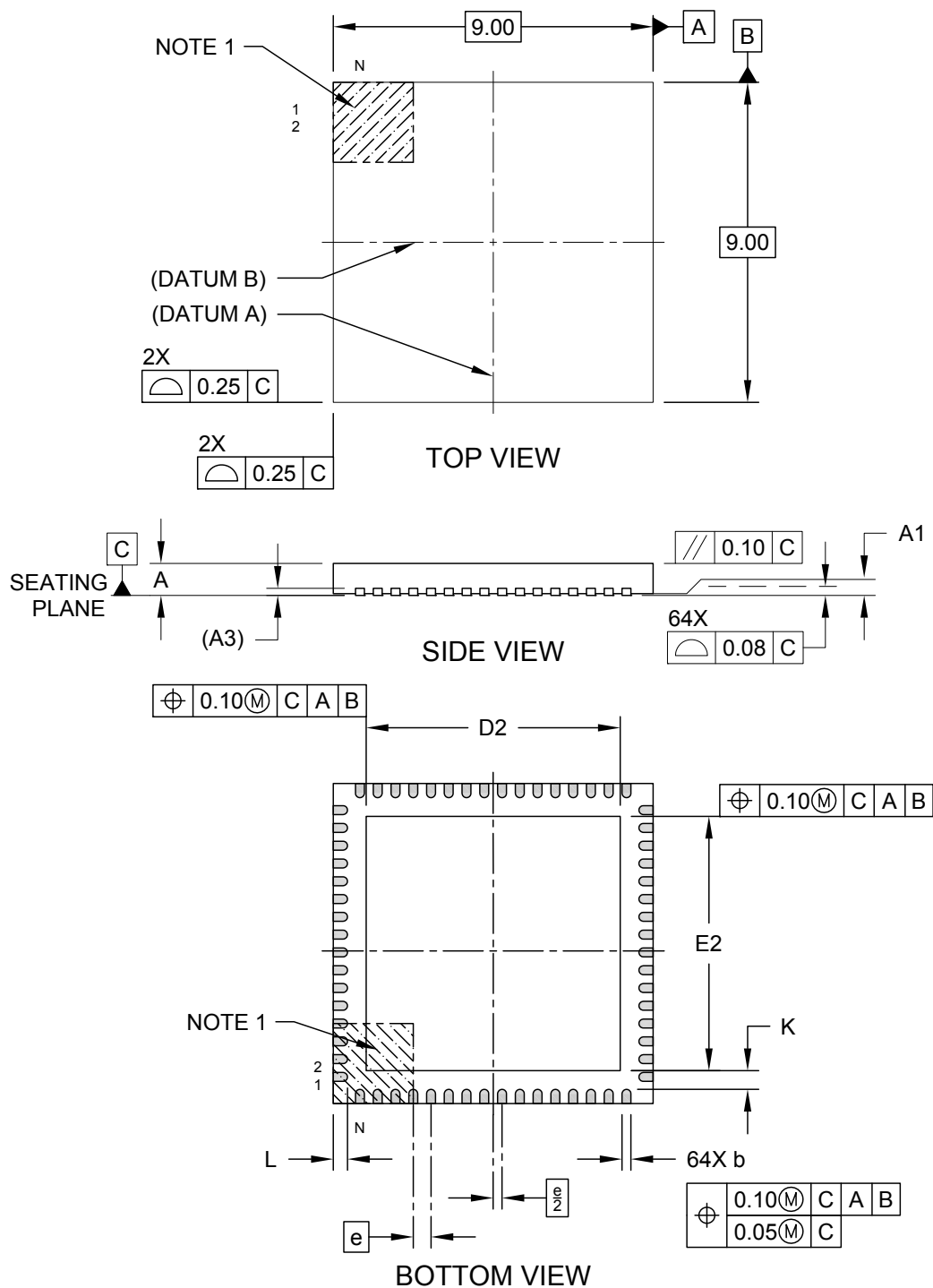

---



---

## Package Outlines and Dimensions

---



---

### 64-Lead Very Thin Plastic Quad Flat, No Lead Package (MR) – 9x9x0.9 mm Body [VQFN] With 7.15 x 7.15 Exposed Pad [Also called QFN]

**Note:** For the most current package drawings, please see the Microchip Packaging Specification located at <http://www.microchip.com/packaging>

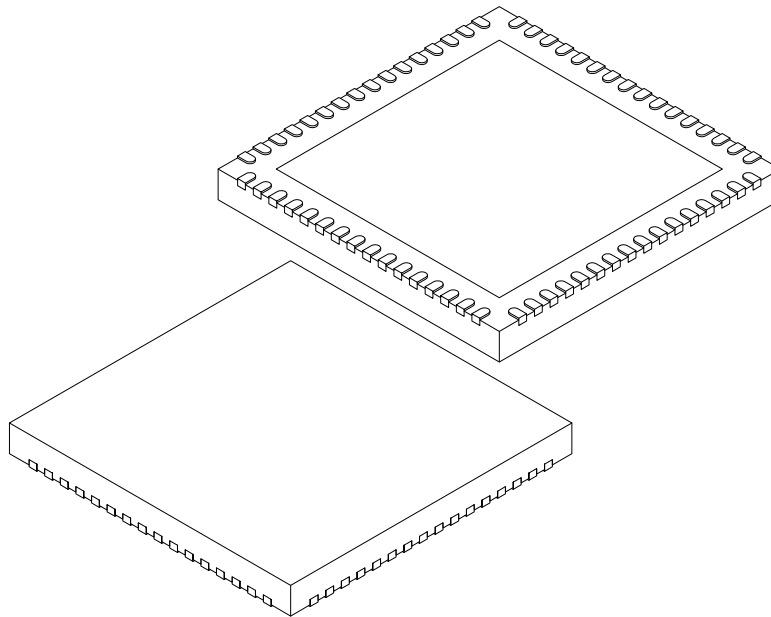

		Units	MILLIMETERS		
Dimension Limits			MIN	NOM	MAX
Number of Pins	N		64		
Pitch	e		0.50 BSC		
Overall Height	A	0.80	0.90	1.00	
Standoff	A1	0.00	0.02	0.05	
Contact Thickness	A3	0.20 REF			
Overall Width	E	9.00 BSC			
Exposed Pad Width	E2	7.05	7.15	7.25	
Overall Length	D	9.00 BSC			
Exposed Pad Length	D2	7.05	7.15	7.25	
Contact Width	b	0.18	0.25	0.30	
Contact Length	L	0.30	0.40	0.50	
Contact-to-Exposed Pad	K	0.20	-	-	

**Notes:**

1. Pin 1 visual index feature may vary, but must be located within the hatched area.
2. Package is saw singulated
3. Dimensioning and tolerancing per ASME Y14.5M

BSC: Basic Dimension. Theoretically exact value shown without tolerances.

REF: Reference Dimension, usually without tolerance, for information purposes only.

**Footprint Outlines and Dimensions**

**64-Lead Very Thin Plastic Quad Flat, No Lead Package (MR) – 9x9x0.9 mm Body [VQFN]  
With 7.15 x 7.15 Exposed Pad [Also called QFN]**

**Note:** For the most current package drawings, please see the Microchip Packaging Specification located at <http://www.microchip.com/packaging>

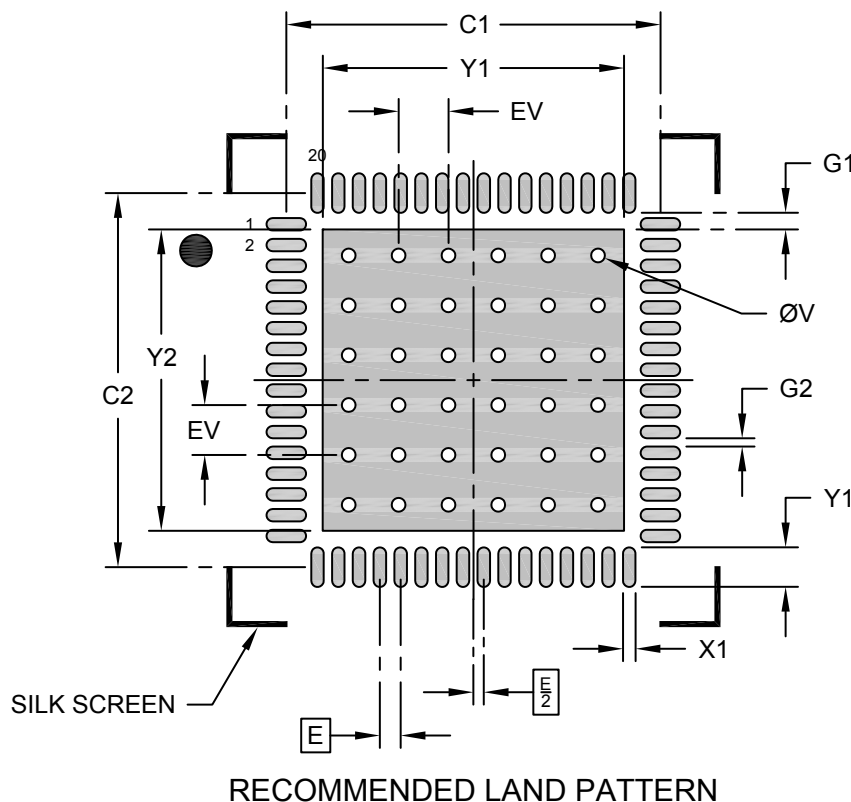

Dimension Limits	Units	MILLIMETERS		
		MIN	NOM	MAX
Contact Pitch	E	0.50 BSC		
Optional Center Pad Width	X2			7.25
Optional Center Pad Length	Y2			7.25
Contact Pad Spacing	C1		9.00	
Contact Pad Spacing	C2		9.00	
Contact Pad Width (X64)	X1			0.30
Contact Pad Length (X64)	Y1			0.95
Contact Pad to Center Pad (X64)	G1	0.40		
Spacing Between Contact Pads (X60)	G2	0.20		
Thermal Via Diameter	V		0.33	
Thermal Via Pitch	EV		1.20	

**Notes:**

- Dimensioning and tolerancing per ASME Y14.5M  
BSC: Basic Dimension. Theoretically exact value shown without tolerances.
- For best soldering results, thermal vias, if used, should be filled or tented to avoid solder loss during reflow process

**Package Outlines and Dimensions**

**64-Lead Very Thin Plastic Quad Flat, No Lead Package (R4X) – 9x9x0.9 mm Body [VQFN]  
With 7.15 x 7.15 Exposed Pad [Also called QFN]**

**Note:** For the most current package drawings, please see the Microchip Packaging Specification located at <http://www.microchip.com/packaging>

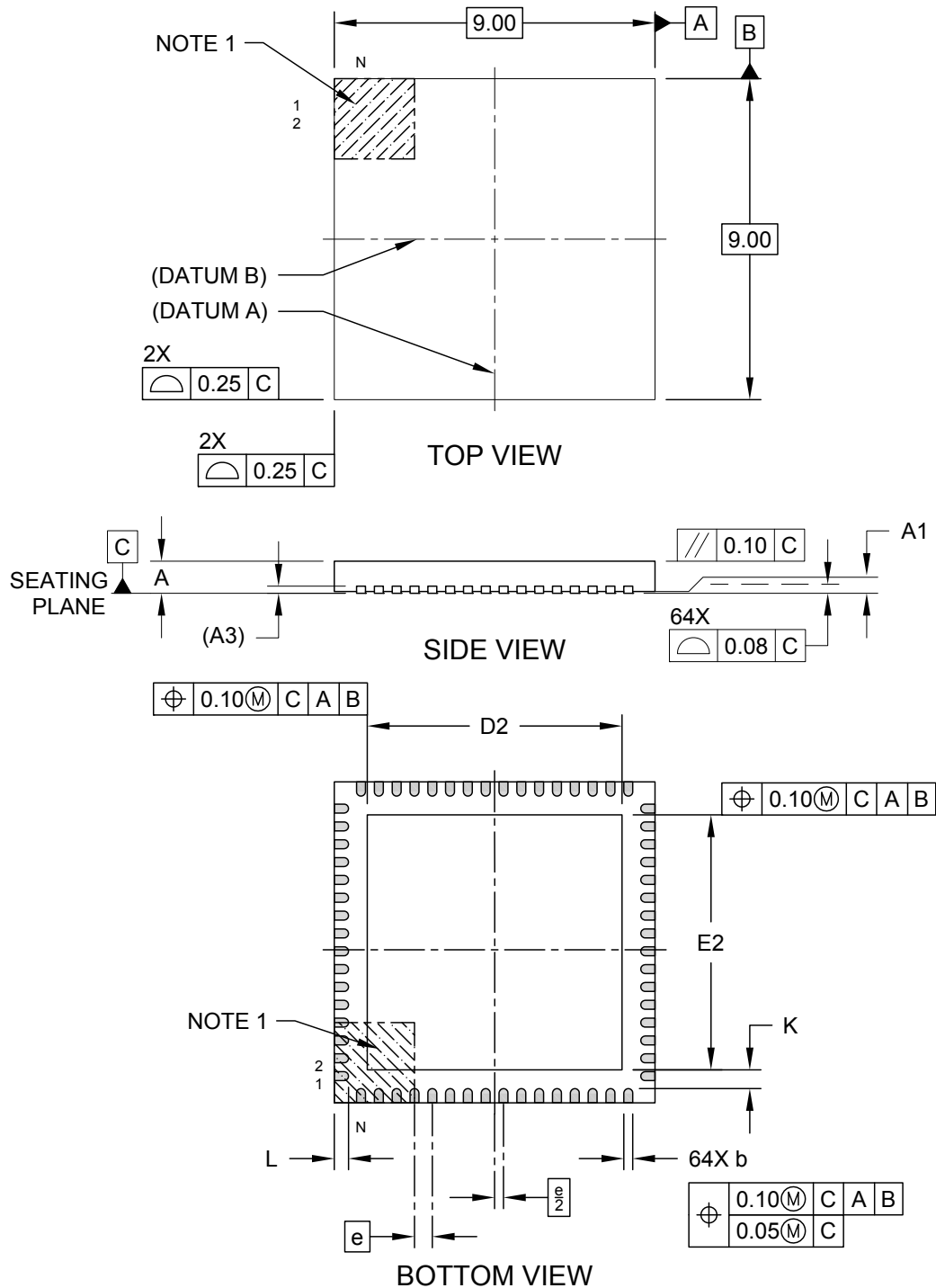

**Package Outlines and Dimensions**

**64-Lead Very Thin Plastic Quad Flat, No Lead Package (R4X) – 9x9x0.9 mm Body [VQFN]  
With 7.15 x 7.15 Exposed Pad [Also called QFN]**

**Note:** For the most current package drawings, please see the Microchip Packaging Specification located at <http://www.microchip.com/packaging>

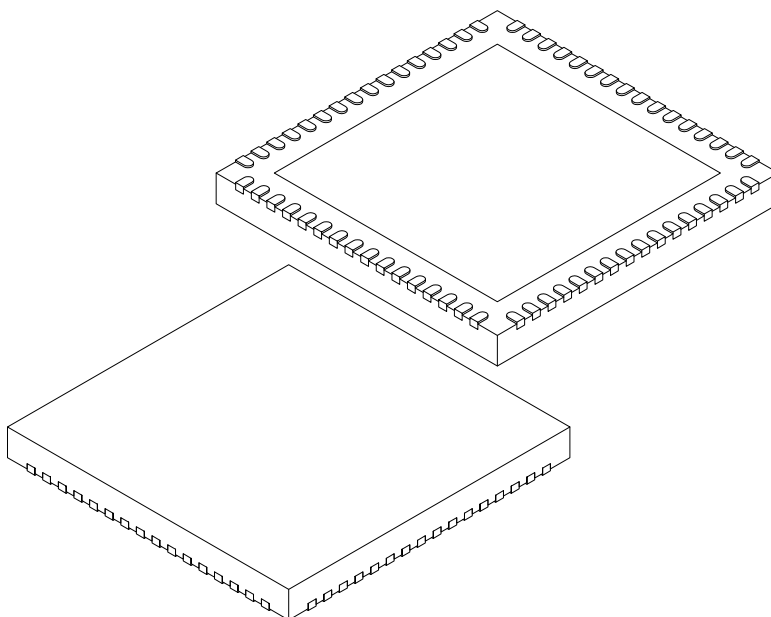

Dimension Limits	Units	MILLIMETERS		
		MIN	NOM	MAX
Number of Pins	N	64		
Pitch	e	0.50 BSC		
Overall Height	A	0.80	0.90	1.00
Standoff	A1	0.00	0.02	0.05
Contact Thickness	A3	0.20 REF		
Overall Width	E	9.00 BSC		
Exposed Pad Width	E2	7.05	7.15	7.25
Overall Length	D	9.00 BSC		
Exposed Pad Length	D2	7.05	7.15	7.25
Contact Width	b	0.18	0.25	0.30
Contact Length	L	0.30	0.40	0.50
Contact-to-Exposed Pad	K	0.20	-	-

**Notes:**

- Pin 1 visual index feature may vary, but must be located within the hatched area.
- Package is saw singulated
- Dimensioning and tolerancing per ASME Y14.5M
  - BSC: Basic Dimension. Theoretically exact value shown without tolerances.
  - REF: Reference Dimension, usually without tolerance, for information purposes only.

---



---

## Footprint Outlines and Dimensions

---



---

### 64-Lead Very Thin Plastic Quad Flat, No Lead Package (R4X) – 9x9x0.9 mm Body [VQFN] With 7.15 x 7.15 Exposed Pad [Also called QFN]

**Note:** For the most current package drawings, please see the Microchip Packaging Specification located at <http://www.microchip.com/packaging>

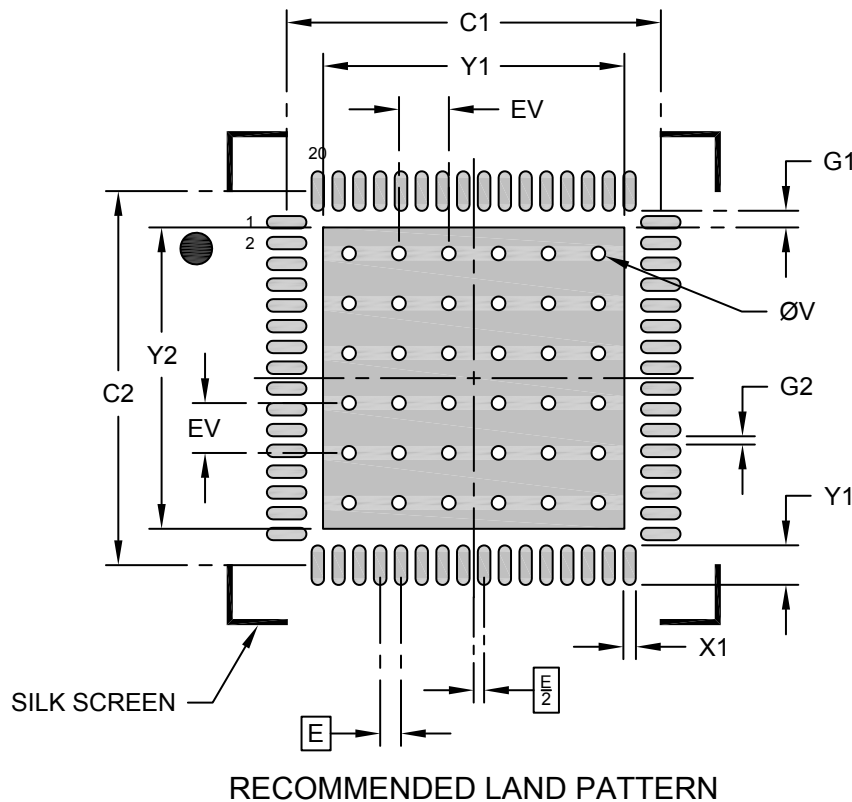

Dimension Limits	Units	MILLIMETERS		
		MIN	NOM	MAX
Contact Pitch	E	0.50 BSC		
Optional Center Pad Width	X2			7.25
Optional Center Pad Length	Y2			7.25
Contact Pad Spacing	C1		9.00	
Contact Pad Spacing	C2		9.00	
Contact Pad Width (X64)	X1			0.30
Contact Pad Length (X64)	Y1			0.95
Contact Pad to Center Pad (X64)	G1	0.40		
Spacing Between Contact Pads (X60)	G2	0.20		
Thermal Via Diameter	V		0.33	
Thermal Via Pitch	EV		1.20	

**Notes:**

1. Dimensioning and tolerancing per ASME Y14.5M  
BSC: Basic Dimension. Theoretically exact value shown without tolerances.
2. For best soldering results, thermal vias, if used, should be filled or tented to avoid solder loss during reflow process

## Package Outlines and Dimensions

### 68-Lead Very Thin Plastic Quad Flat, No Lead Package (VY) - 8x8 mm Body [VQFN] with 6.2x6.2 Exposed Pad; Saw Singulated; ISSC Legacy Package

**Note:** For the most current package drawings, please see the Microchip Packaging Specification located at <http://www.microchip.com/packaging>

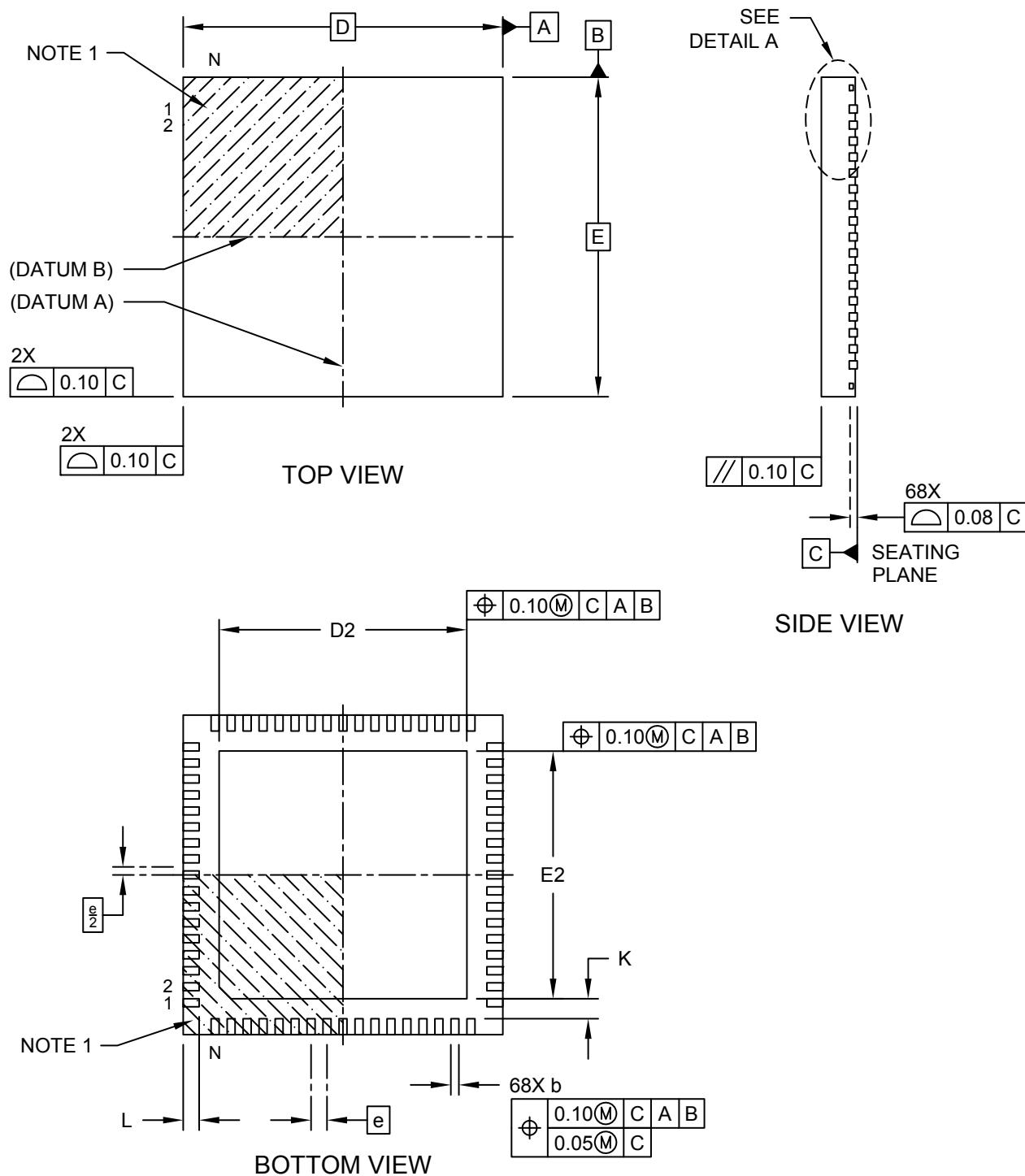

Microchip Technology Drawing C04-354A Sheet 1 of 2



---



---

## Package Outlines and Dimensions

---



---

### 68-Lead Very Thin Plastic Quad Flat, No Lead Package (VY) - 8x8 mm Body [VQFN] with 6.2x6.2 Exposed Pad; Saw Singulated; ISSC Legacy Package

**Note:** For the most current package drawings, please see the Microchip Packaging Specification located at <http://www.microchip.com/packaging>

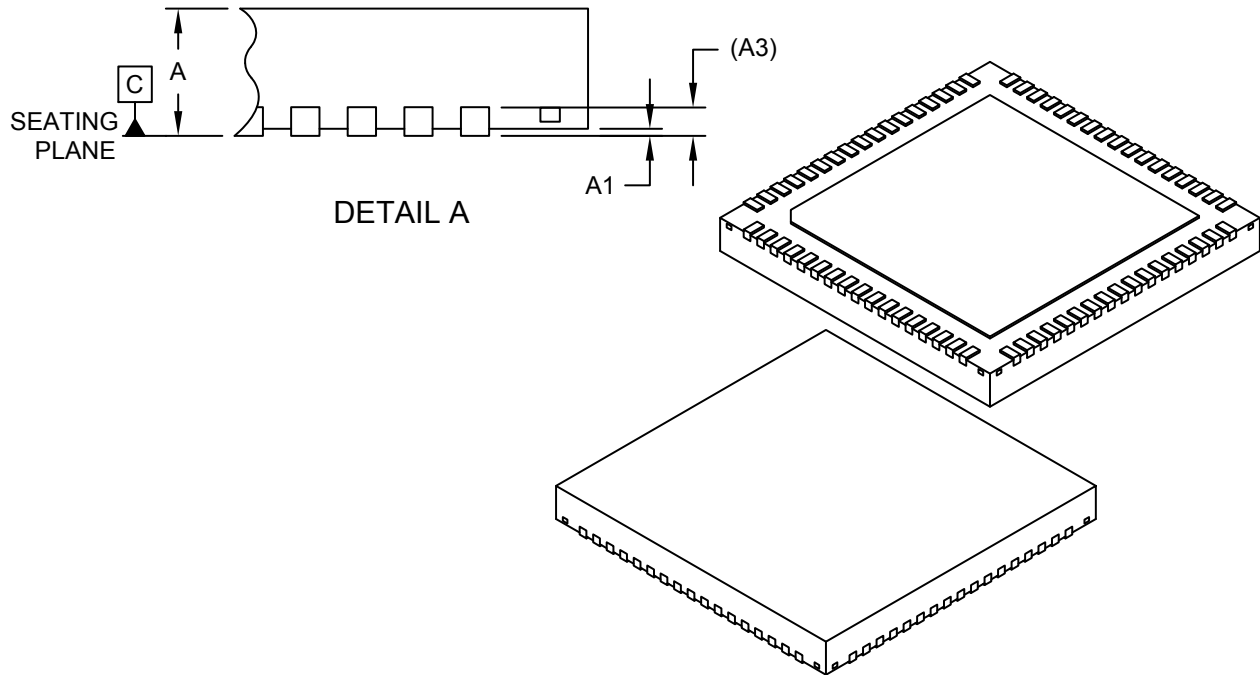

		Units	MILLIMETERS		
Dimension Limits			MIN	NOM	MAX
Number of Terminals	N		68		
Pitch	e		0.40 BSC		
Overall Height	A	0.80	0.85	0.90	
Standoff	A1	0.00	0.02	0.05	
Terminal Thickness	A3	0.203 REF			
Overall Length	D	8.00 BSC			
Exposed Pad Length	D2	6.10	6.20	6.30	
Overall Width	E	8.00 BSC			
Exposed Pad Width	E2	6.10	6.20	6.30	
Terminal Width	b	0.15	0.20	0.25	
Terminal Length	L	0.35	0.40	0.45	
Terminal-to-Exposed-Pad	K	0.20	-	-	

**Notes:**

1. Pin 1 visual index feature may vary, but must be located within the hatched area.
2. Package is saw singulated
3. Dimensioning and tolerancing per ASME Y14.5M
  - BSC: Basic Dimension. Theoretically exact value shown without tolerances.
  - REF: Reference Dimension, usually without tolerance, for information purposes only.

**Footprint Outlines and Dimensions**

**68-Lead Very Thin Plastic Quad Flat, No Lead Package (VY) - 8x8 mm Body [VQFN] with 6.2x6.2 Exposed Pad; Saw Singulated; ISSC Legacy Package**

**Note:** For the most current package drawings, please see the Microchip Packaging Specification located at <http://www.microchip.com/packaging>

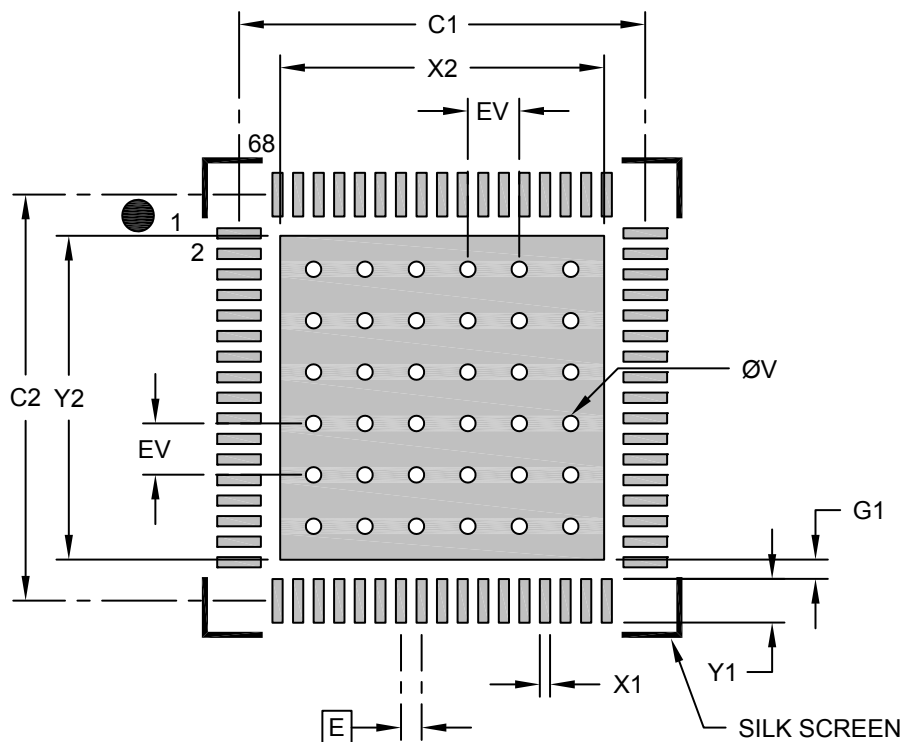

**RECOMMENDED LAND PATTERN**

Dimension Limits	Units	MILLIMETERS		
		MIN	NOM	MAX
Contact Pitch	E	0.40 BSC		
Optional Center Pad Width	X2			6.30
Optional Center Pad Length	Y2			6.30
Contact Pad Spacing	C1		7.90	
Contact Pad Spacing	C2		7.90	
Contact Pad Width (X68)	X1			0.20
Contact Pad Length (X68)	Y1			0.85
Contact Pad to Center Pad (X68)	G1	0.20		
Thermal Via Diameter	V		0.30	
Thermal Via Pitch	EV		1.00	

**Notes:**

1. Dimensioning and tolerancing per ASME Y14.5M  
BSC: Basic Dimension. Theoretically exact value shown without tolerances.
2. For best soldering results, thermal vias, if used, should be filled or tented to avoid solder loss during reflow process

## Package Outlines and Dimensions

### 72-Lead Plastic Quad Flat, No Lead Package (NQ) - 10x10x1.0mm Body [VQFN] 6.0x6.0mm Exposed Pad, 0.40mm Terminal Length

**Note:** For the most current package drawings, please see the Microchip Packaging Specification located at <http://www.microchip.com/packaging>

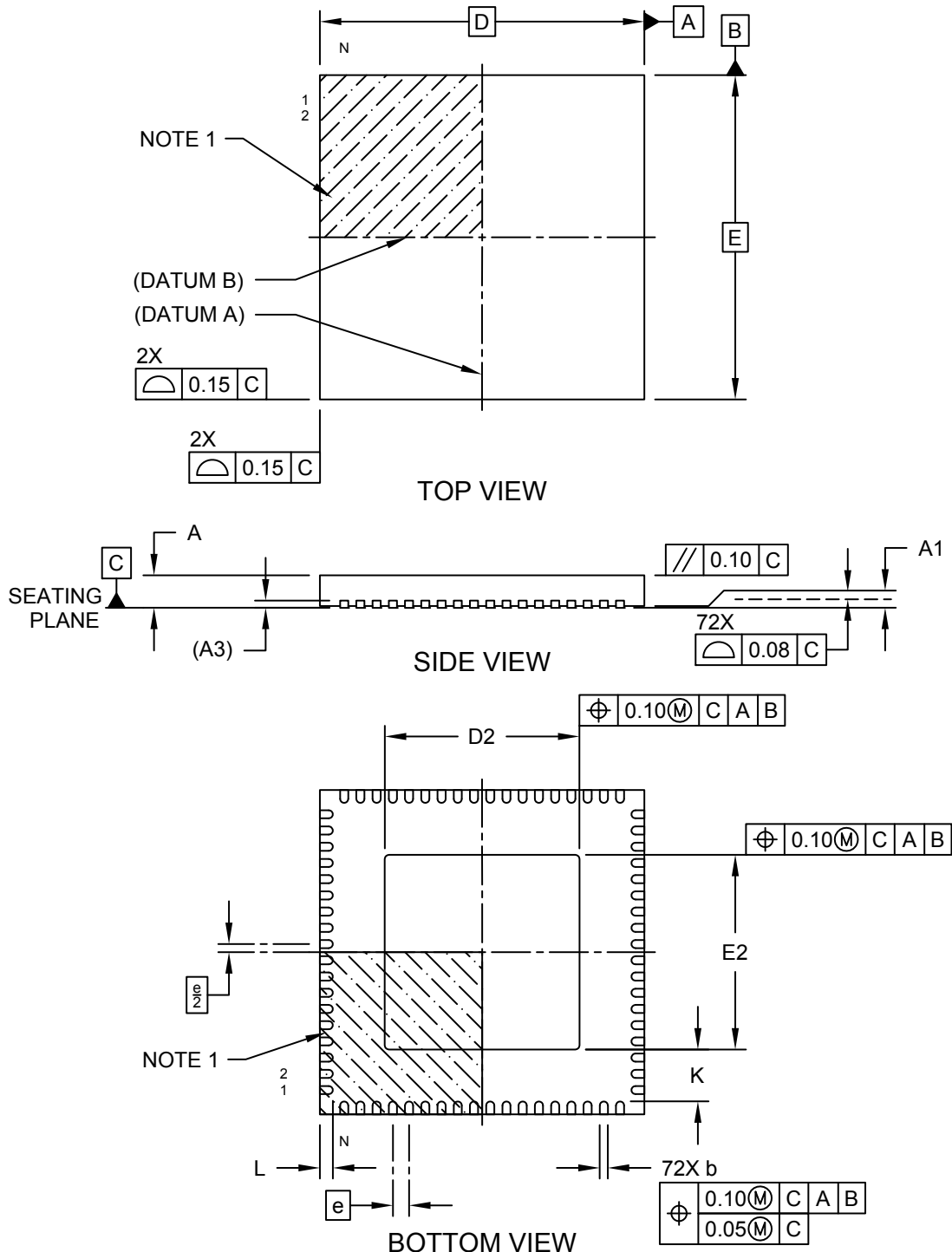

Microchip Technology Drawing C04-202A Sheet 1 of 2

**Package Outlines and Dimensions**

**72-Lead Plastic Quad Flat, No Lead Package (NQ) - 10x10x1.0mm Body [VQFN]  
6.0x6.0mm Exposed Pad, 0.40mm Terminal Length**

**Note:** For the most current package drawings, please see the Microchip Packaging Specification located at <http://www.microchip.com/packaging>

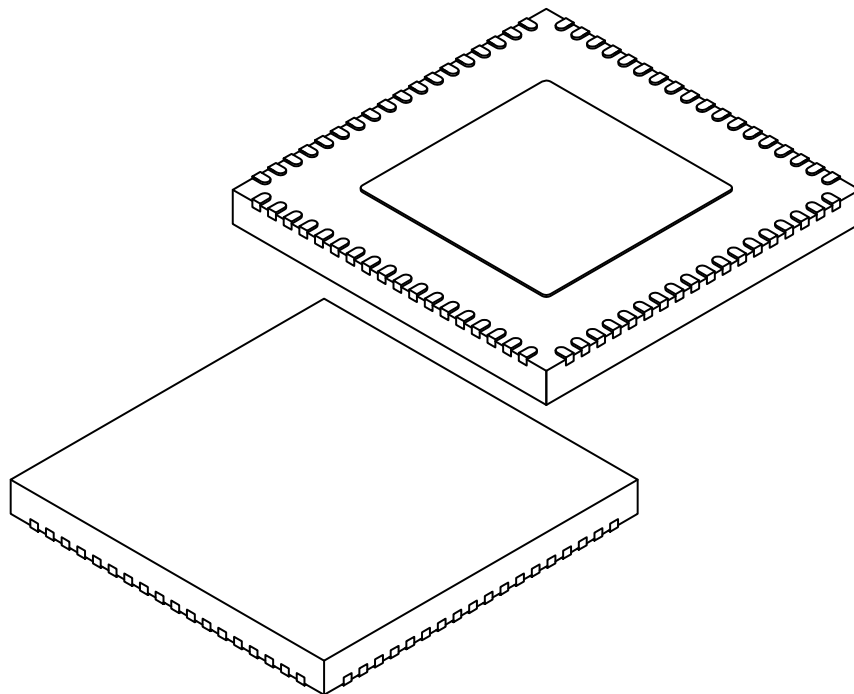

		Units	MILLIMETERS		
Dimension Limits			MIN	NOM	MAX
Number of Terminals	N		72		
Pitch	e		0.50 BSC		
Overall Height	A	0.80	0.90	1.00	
Standoff	A1	0.00	0.02	0.05	
Contact Thickness	A3	0.20 REF			
Overall Width	E	10.00 BSC			
Exposed Pad Width	E2	5.90	6.00	6.10	
Overall Length	D	10.00 BSC			
Exposed Pad Length	D2	5.90	6.00	6.10	
Contact Width	b	0.18	0.25	0.30	
Contact Length	L	0.30	0.40	0.50	
Contact-to-Exposed Pad	K	1.50	1.60	-	

**Notes:**

1. Pin 1 visual index feature may vary, but must be located within the hatched area.
2. Package is saw singulated
3. Dimensioning and tolerancing per ASME Y14.5M

BSC: Basic Dimension. Theoretically exact value shown without tolerances.

REF: Reference Dimension, usually without tolerance, for information purposes only.

---



---

## Footprint Outlines and Dimensions

---



---

### 72-Lead Plastic Quad Flat, No Lead Package (NQ) - 10x10x1.0mm Body [VQFN] 6.0x6.0mm Exposed Pad, 0.40mm Terminal Length

**Note:** For the most current package drawings, please see the Microchip Packaging Specification located at <http://www.microchip.com/packaging>

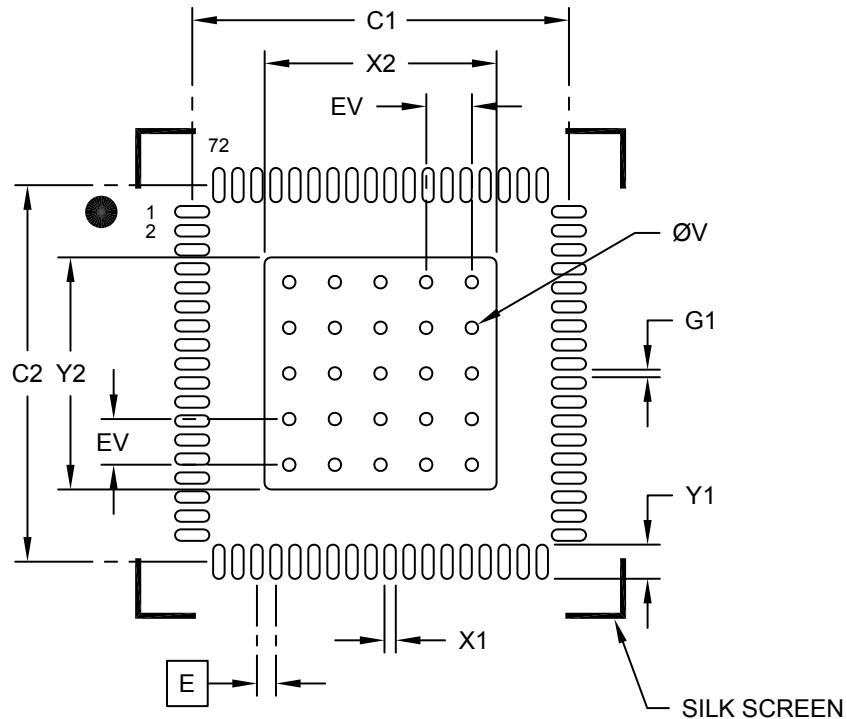

### RECOMMENDED LAND PATTERN

Dimension Limits	Units	MILLIMETERS		
		MIN	NOM	MAX
Contact Pitch	E	0.50 BSC		
Optional Center Pad Width	X2			6.10
Optional Center Pad Length	Y2			6.10
Contact Pad Spacing	C1		9.90	
Contact Pad Spacing	C2		9.90	
Contact Pad Width (X72)	X1			0.30
Contact Pad Length (X72)	Y1			0.90
Contact Pad to Center Pad (X68)	G1	0.20		
Thermal Via Diameter	V		0.33	
Thermal Via Pitch	EV		1.20	

**Notes:**

1. Dimensioning and tolerancing per ASME Y14.5M  
BSC: Basic Dimension. Theoretically exact value shown without tolerances.
2. For best soldering results, thermal vias, if used, should be filled or tented to avoid solder loss during reflow process

**Package Outlines and Dimensions**

**72-Lead Plastic Quad Flat, No Lead Package (6E) - 10x10 mm Body [VQFN]  
6.0x6.0 mm Exposed Pad; Punch Singulated, Dimpled Terminals (Also called QFN)**

**Note:** For the most current package drawings, please see the Microchip Packaging Specification located at <http://www.microchip.com/packaging>

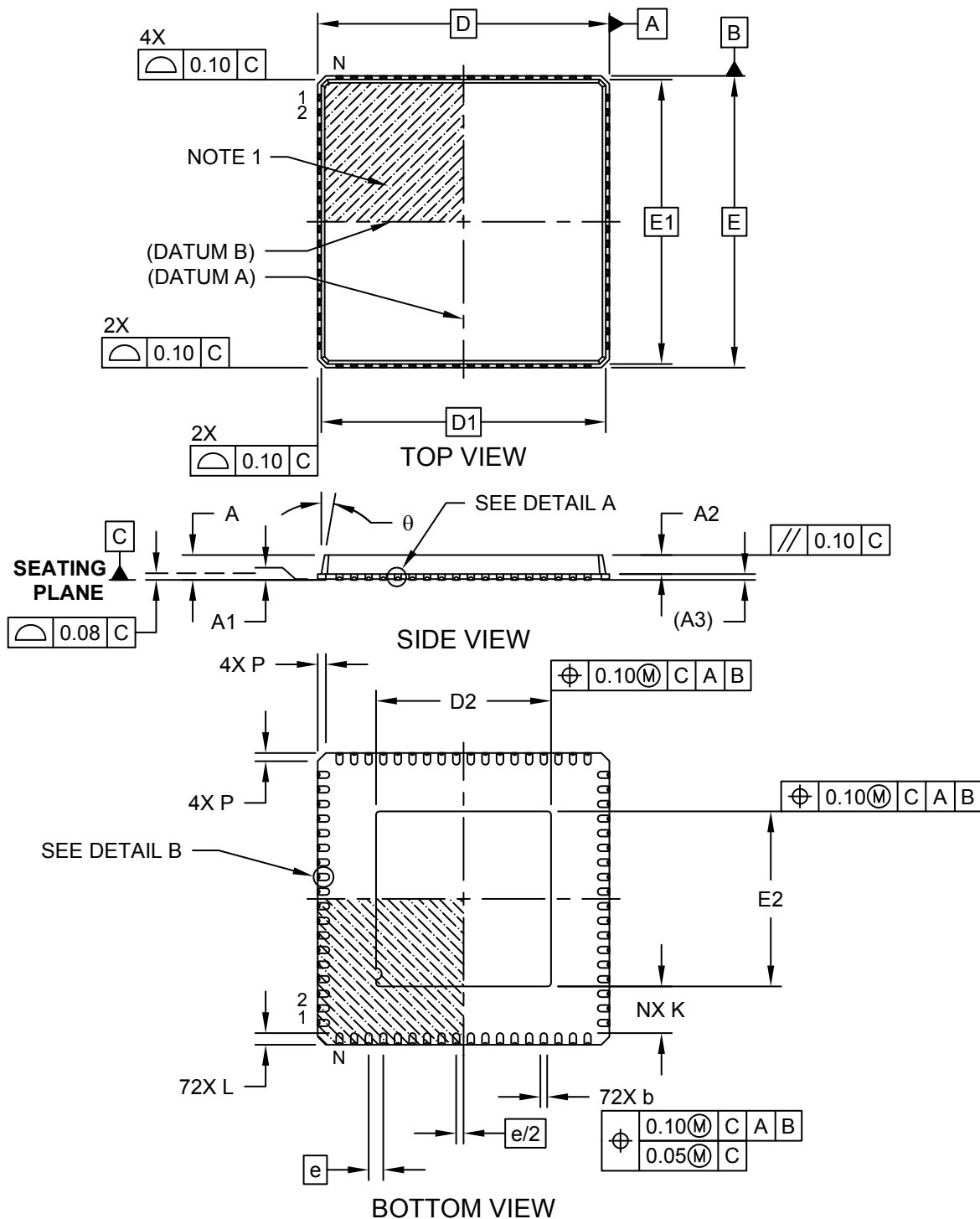

---



---

## Package Outlines and Dimensions

---



---

### 72-Lead Plastic Quad Flat, No Lead Package (6E) - 10x10 mm Body [VQFN] 6.0x6.0 mm Exposed Pad; Punch Singulated, Dimpled Terminals (Also called QFN)

**Note:** For the most current package drawings, please see the Microchip Packaging Specification located at <http://www.microchip.com/packaging>

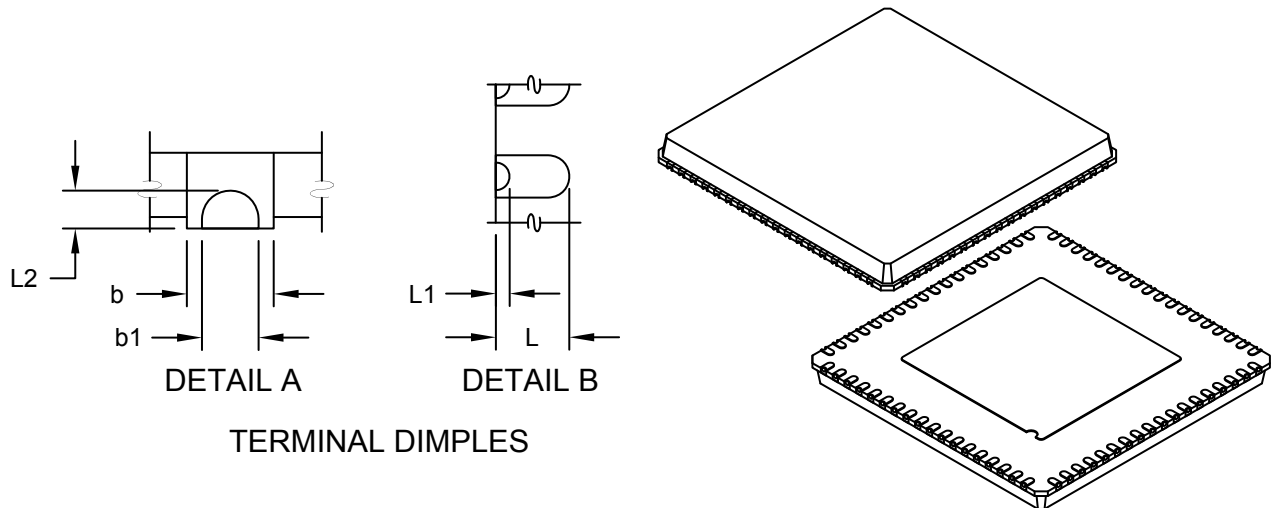

TERMINAL DIMPLES

		Units	MILLIMETERS		
		Dimension Limits	MIN	NOM	MAX
Number of Pins	N		72		
Pitch	e		0.50 BSC		
Overall Height	A		0.80	0.85	0.90
Standoff	A1		0.00	0.01	0.05
Mold Cap Height	A2		0.60	0.65	0.70
Terminal Thickness	A3		0.20 REF		
Overall Width	E		10.00 BSC		
Molded Top Width	E1		9.75 BSC		
Exposed Pad Width	E2		5.90	6.00	6.10
Overall Length	D		10.00 BSC		
Molded Top Length	D1		9.75 BSC		
Exposed Pad Length	D2		5.90	6.00	6.10
Corner Chamfer	P		0.24	0.42	0.60
Terminal Width	b		0.18	0.23	0.30
Terminal Dimple Width	b1		0.10	0.15	0.20
Terminal Length	L		0.30	0.40	0.50
Terminal Dimple Length (side)	L1		0.05	0.15	0.25
Terminal Dimple Length (bottom)	L2		0.05	0.10	0.15
Terminal-to-Exposed-Pad	K		0.20	-	-
Mold Draft Angle	$\theta$		0°	-	12°

**Notes:**

1. Pin 1 visual index feature may vary, but must be located within the hatched area.
2. Package is punch singulated
3. Dimensioning and tolerancing per ASME Y14.5M

BSC: Basic Dimension. Theoretically exact value shown without tolerances.

REF: Reference Dimension, usually without tolerance, for information purposes only.

**Footprint Outlines and Dimensions**

**72-Lead Plastic Quad Flat, No Lead Package (6E) - 10x10 mm Body [VQFN]  
6.0x6.0 mm Exposed Pad; Punch Singulated, Dimpled Terminals (Also called QFN)**

**Note:** For the most current package drawings, please see the Microchip Packaging Specification located at <http://www.microchip.com/packaging>

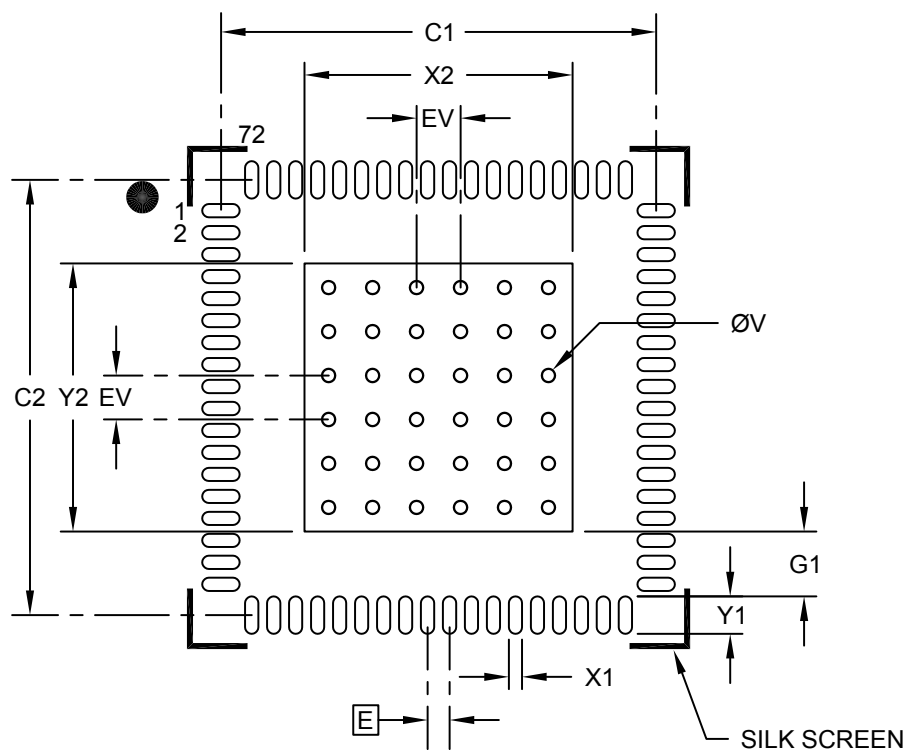

**RECOMMENDED LAND PATTERN**

Dimension Limits	Units	MILLIMETERS		
		MIN	NOM	MAX
Contact Pitch	E	0.50 BSC		
Optional Center Pad Width	X2			6.10
Optional Center Pad Length	Y2			6.10
Contact Pad Spacing	C1		9.90	
Contact Pad Spacing	C2		9.90	
Contact Pad Width (X72)	X1			0.30
Contact Pad Length (X72)	Y1			0.85
Contact Pad to Center Pad (X72)	G1	0.20		
Thermal Via Diameter	V		0.30	
Thermal Via Pitch	EV		1.00	

**Notes:**

1. Dimensioning and tolerancing per ASME Y14.5M  
BSC: Basic Dimension. Theoretically exact value shown without tolerances.
2. For best soldering results, thermal vias, if used, should be "filled" or "tented" to avoid solder loss during reflow process



**Package Outlines and Dimensions**

**76-Lead Very Thin Plastic Quad Flat, No Lead Package (QBA) - 9x9 mm Body [VQFN]  
With 5x5 mm Exposed Pad**

**Note:** For the most current package drawings, please see the Microchip Packaging Specification located at <http://www.microchip.com/packaging>

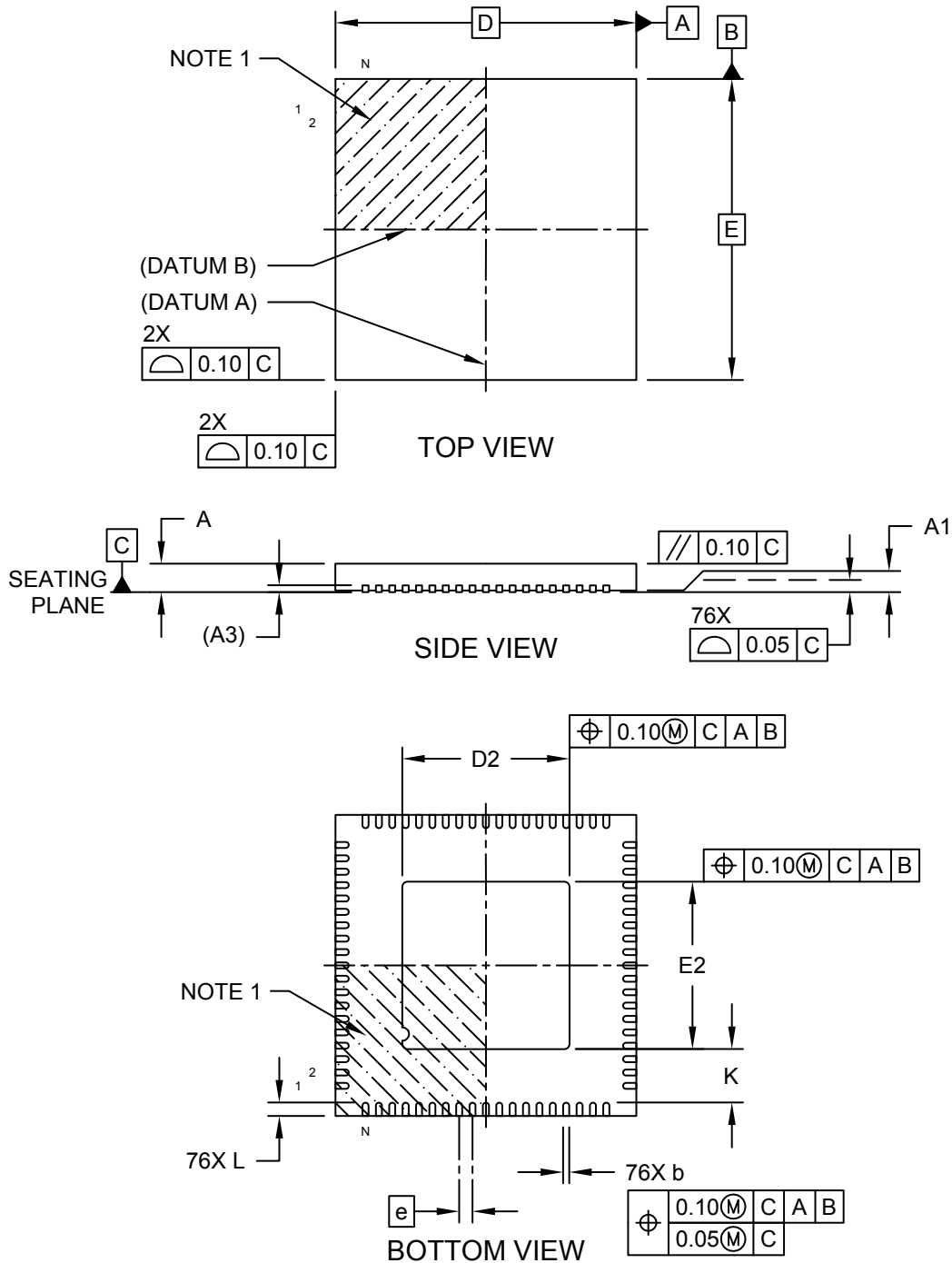

**Package Outlines and Dimensions**

**76-Lead Very Thin Plastic Quad Flat, No Lead Package (QBA) - 9x9 mm Body [VQFN]  
With 5x5 mm Exposed Pad**

**Note:** For the most current package drawings, please see the Microchip Packaging Specification located at <http://www.microchip.com/packaging>

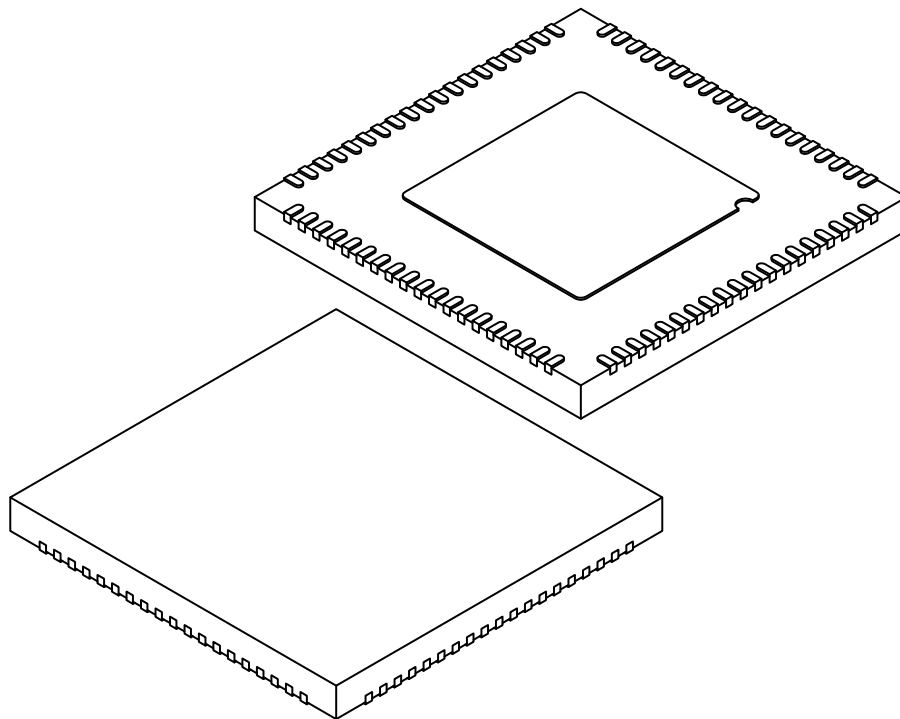

Dimension Limits	Units	MILLIMETERS		
		MIN	NOM	MAX
Number of Terminals	N	76		
Pitch	e	0.40 BSC		
Overall Height	A	0.80	0.85	0.9
Standoff	A1	0.00	0.02	0.05
Terminal Thickness	A3	0.20 REF		
Overall Length	D	9.00 BSC		
Exposed Pad Length	D2	4.90	5.00	5.10
Overall Width	E	9.00 BSC		
Exposed Pad Width	E2	4.90	5.00	5.10
Terminal Width	b	0.13	0.18	0.23
Terminal Length	L	0.35	0.40	0.45
Terminal-to-Exposed-Pad	K	0.20	-	-

**Notes:**

1. Pin 1 visual index feature may vary, but must be located within the hatched area.
2. Package is saw singulated
3. Dimensioning and tolerancing per ASME Y14.5M

BSC: Basic Dimension. Theoretically exact value shown without tolerances.

REF: Reference Dimension, usually without tolerance, for information purposes only.

---



---

## Footprint Outlines and Dimensions

---



---

### 76-Lead Very Thin Plastic Quad Flat, No Lead Package (QBA) - 9x9 mm Body [VQFN] With 5x5 mm Exposed Pad

**Note:** For the most current package drawings, please see the Microchip Packaging Specification located at <http://www.microchip.com/packaging>

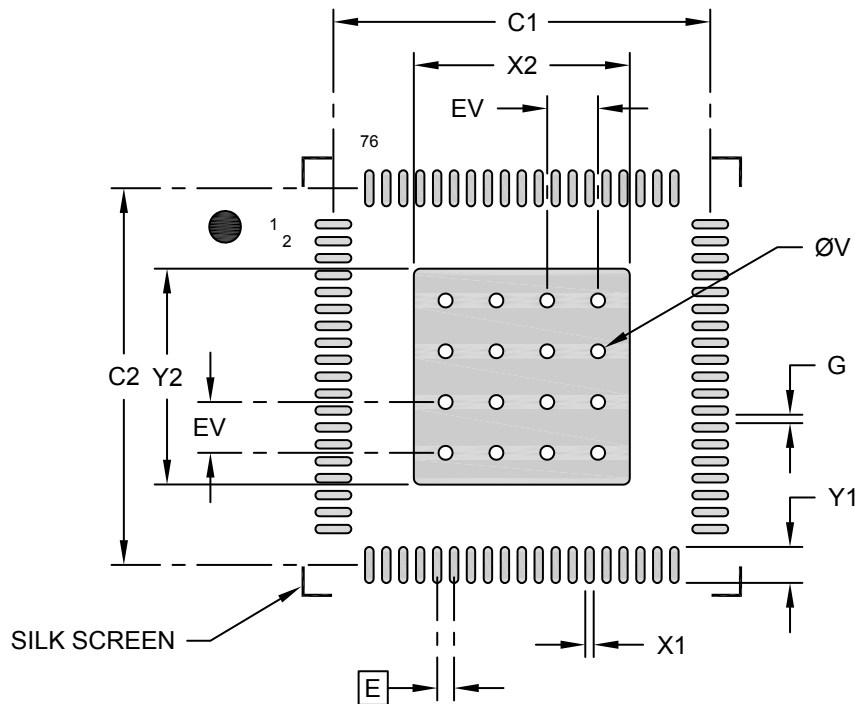

### RECOMMENDED LAND PATTERN

Dimension Limits	Units	MILLIMETERS		
		MIN	NOM	MAX
Contact Pitch	E	0.40 BSC		
Optional Center Pad Width	X2			5.10
Optional Center Pad Length	Y2			5.10
Contact Pad Spacing	C1		8.90	
Contact Pad Spacing	C2		8.90	
Contact Pad Width (X76)	X1			0.20
Contact Pad Length (X76)	Y1			0.85
Contact Pad to Contact Pad (X72)	G	0.20		
Thermal Via Diameter	V		0.33	
Thermal Via Pitch	EV		1.20	

**Notes:**

1. Dimensioning and tolerancing per ASME Y14.5M  
BSC: Basic Dimension. Theoretically exact value shown without tolerances.
2. For best soldering results, thermal vias, if used, should be filled or tented to avoid solder loss during reflow process

**Package Outlines and Dimensions**

**88-Lead Very Thin Plastic Quad Flat, No Lead Package (PJ) - 12x12 mm Body [VQFN]**

**Note:** For the most current package drawings, please see the Microchip Packaging Specification located at <http://www.microchip.com/packaging>

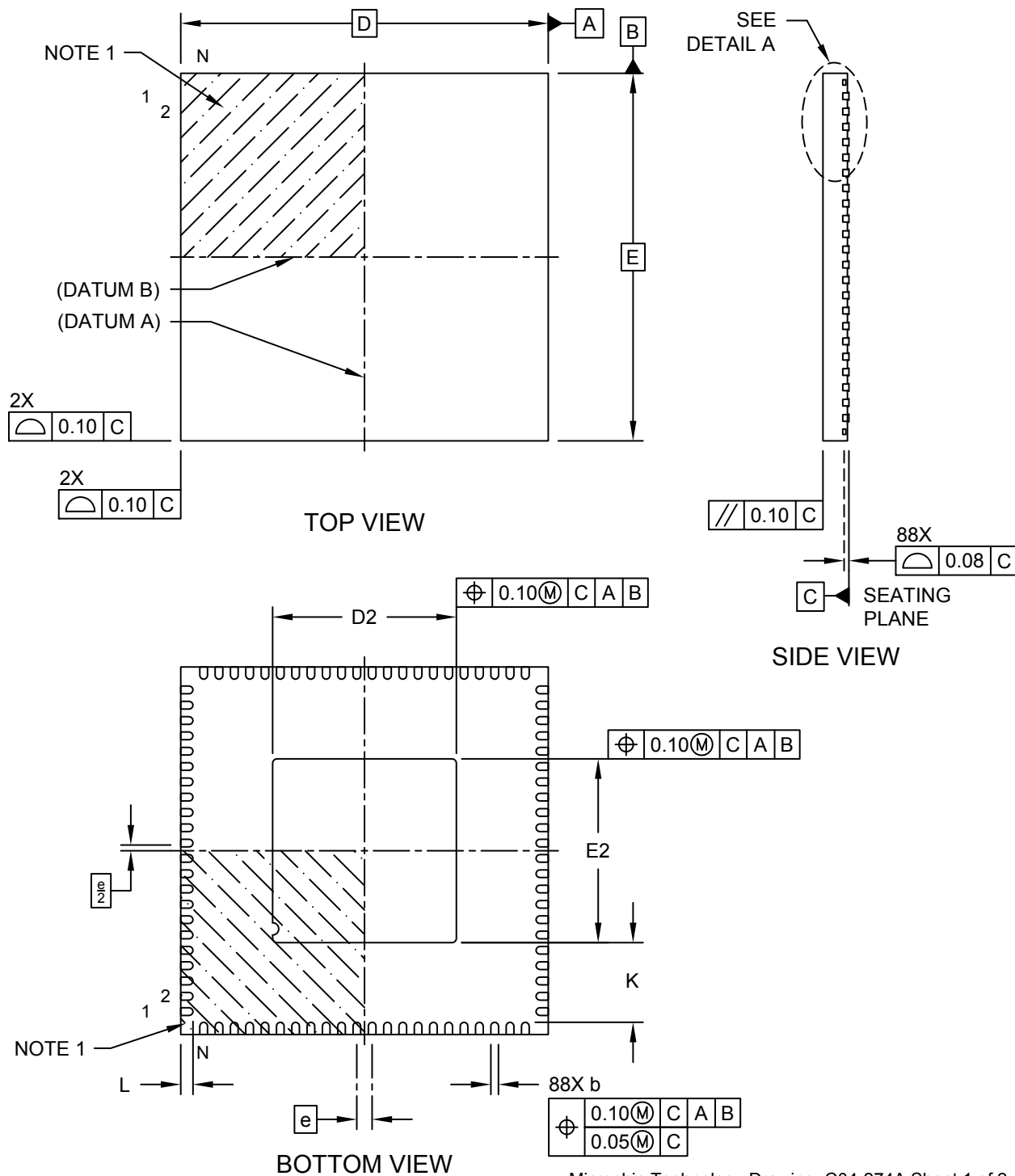

Microchip Technology Drawing C04-274A Sheet 1 of 2

---



---

## Package Outlines and Dimensions

---



---

### 88-Lead Very Thin Plastic Quad Flat, No Lead Package (PJ) - 12x12 mm Body [VQFN]

**Note:** For the most current package drawings, please see the Microchip Packaging Specification located at <http://www.microchip.com/packaging>

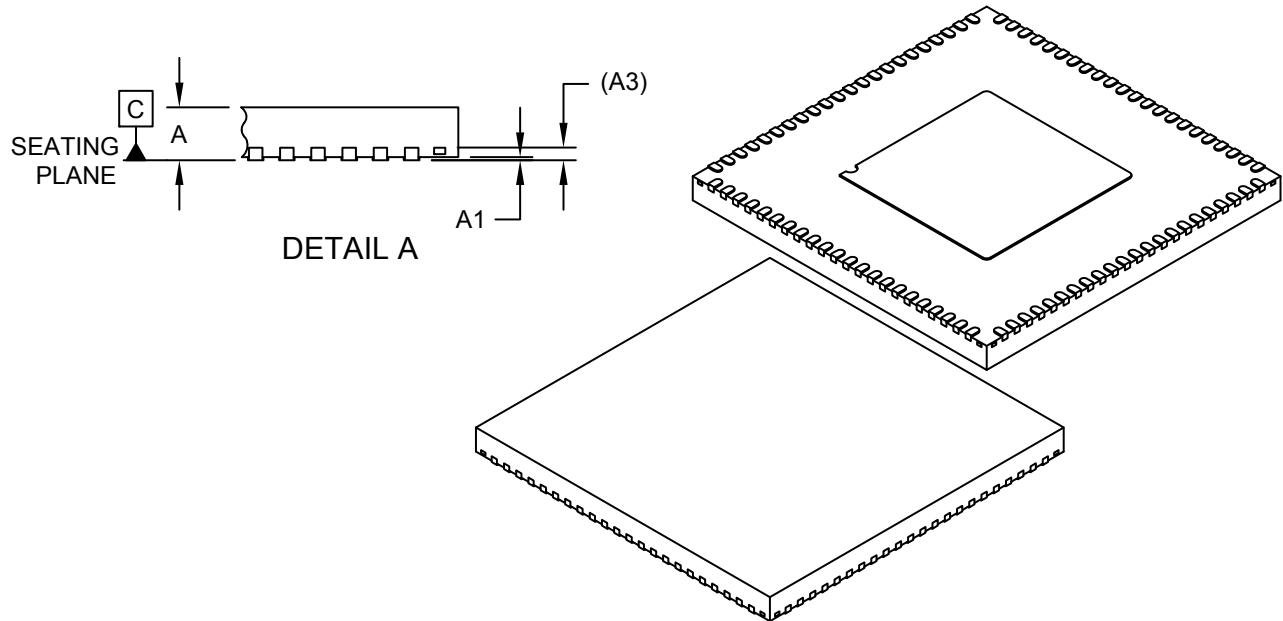

		Units	MILLIMETERS		
Dimension Limits			MIN	NOM	MAX
Number of Terminals	N		88		
Pitch	e		0.50 BSC		
Overall Height	A	0.80	0.85	0.90	
Standoff	A1	0.00	0.02	0.05	
Terminal Thickness	A3	0.203 REF			
Overall Length	D	12.00 BSC			
Exposed Pad Length	D2	5.90	6.00	6.10	
Overall Width	E	12.00 BSC			
Exposed Pad Width	E2	5.90	6.00	6.10	
Terminal Width	b	0.18	0.25	0.30	
Terminal Length	L	0.30	0.40	0.50	
Terminal-to-Exposed-Pad	K	2.50	-	-	

**Notes:**

1. Pin 1 visual index feature may vary, but must be located within the hatched area.
2. Package is saw singulated
3. Dimensioning and tolerancing per ASME Y14.5M

BSC: Basic Dimension. Theoretically exact value shown without tolerances.

REF: Reference Dimension, usually without tolerance, for information purposes only.

**Footprint Outlines and Dimensions**

**88-Lead Very Thin Plastic Quad Flat, No Lead Package (PJ) - 12x12 mm Body [VQFN]**

**Note:** For the most current package drawings, please see the Microchip Packaging Specification located at <http://www.microchip.com/packaging>

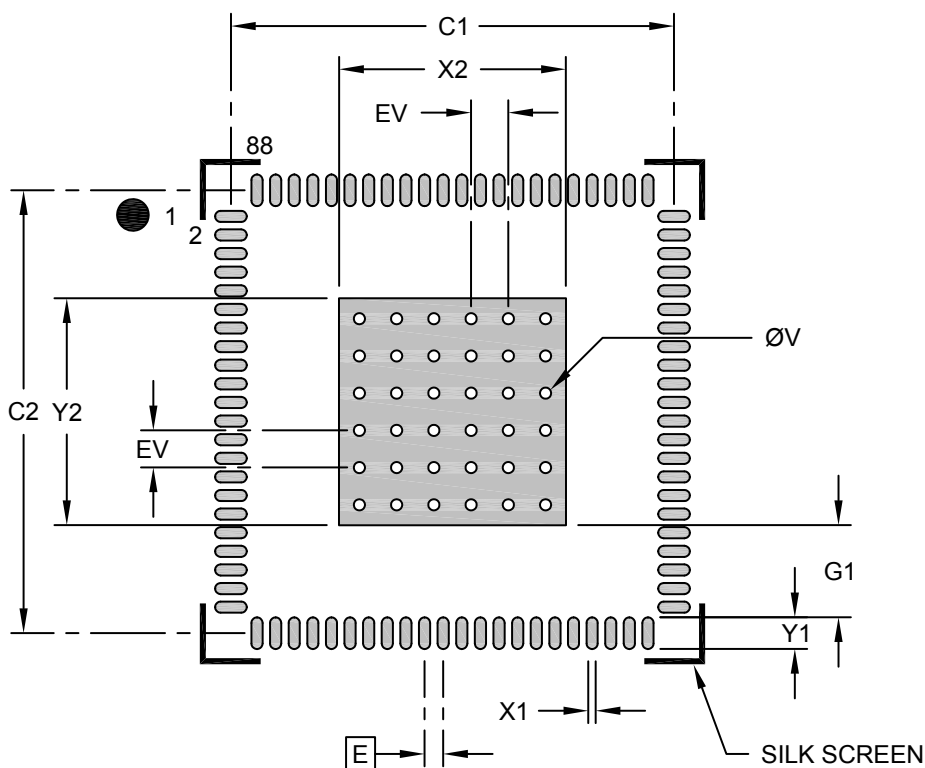

**RECOMMENDED LAND PATTERN**

Dimension Limits	Units	MILLIMETERS		
		MIN	NOM	MAX
Contact Pitch	E	0.50 BSC		
Optional Center Pad Width	X2			6.10
Optional Center Pad Length	Y2			6.10
Contact Pad Spacing	C1		11.90	
Contact Pad Spacing	C2		11.90	
Contact Pad Width (X88)	X1			0.30
Contact Pad Length (X88)	Y1			0.85
Contact Pad to Center Pad (X88)	G1	0.20		
Thermal Via Diameter	V		0.30	
Thermal Via Pitch	EV		1.00	

**Notes:**

- Dimensioning and tolerancing per ASME Y14.5M  
BSC: Basic Dimension. Theoretically exact value shown without tolerances.
- For best soldering results, thermal vias, if used, should be filled or tented to avoid solder loss during reflow process

**Package Outlines and Dimensions**

**88-Lead Very Thin Plastic Quad Flat, No Lead Package (KB) - 12x12x0.9 mm Body [VQFN] Punch Singulated, Wettable Flanks, 6.0x6.0mm Exposed Pad**

**Note:** For the most current package drawings, please see the Microchip Packaging Specification located at <http://www.microchip.com/packaging>

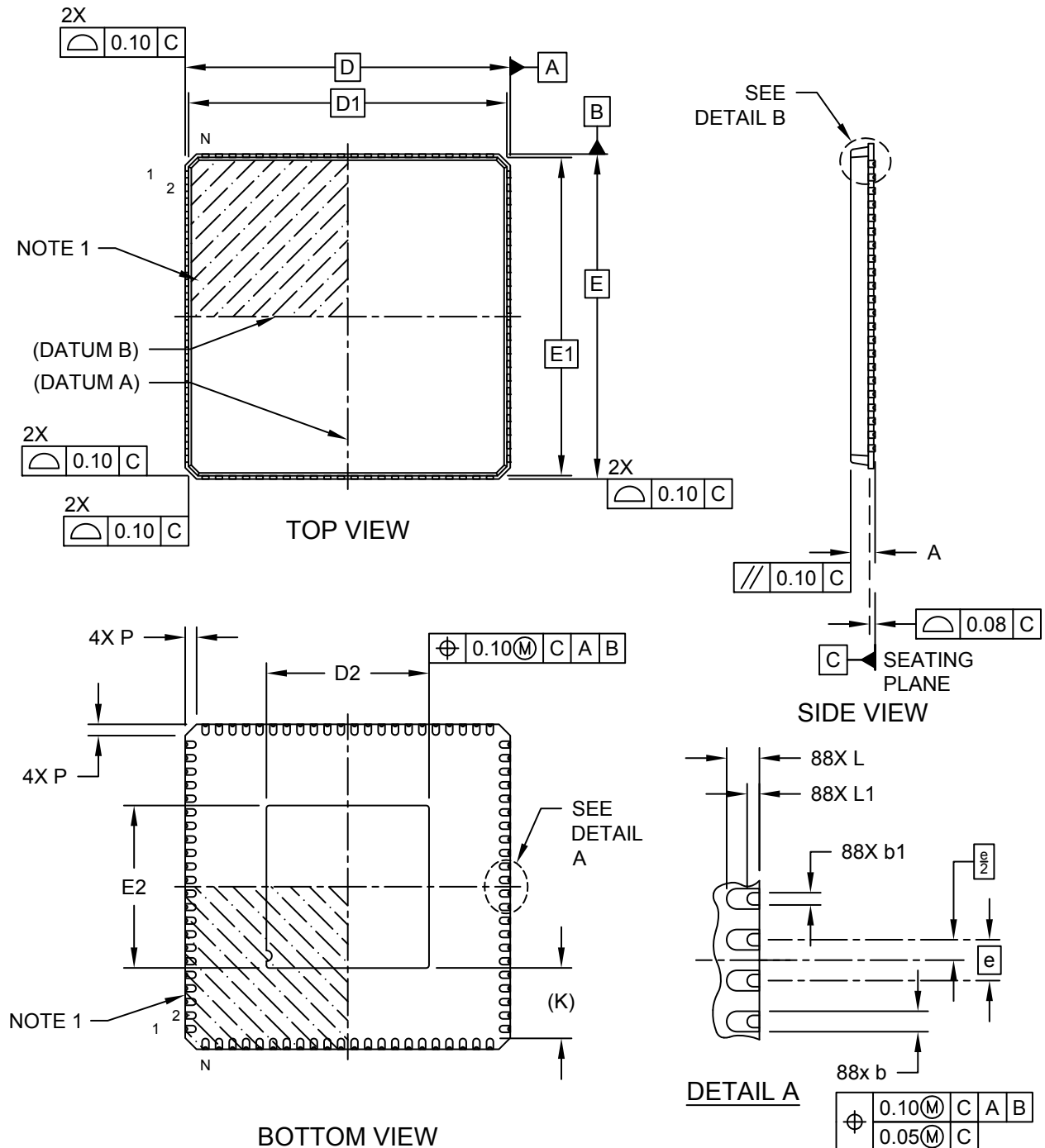

**Package Outlines and Dimensions**

**88-Lead Very Thin Plastic Quad Flat, No Lead Package (KB) - 12x12x0.9 mm Body [VQFN] Punch Singulated, Wettable Flanks, 6.0x6.0mm Exposed Pad**

**Note:** For the most current package drawings, please see the Microchip Packaging Specification located at <http://www.microchip.com/packaging>

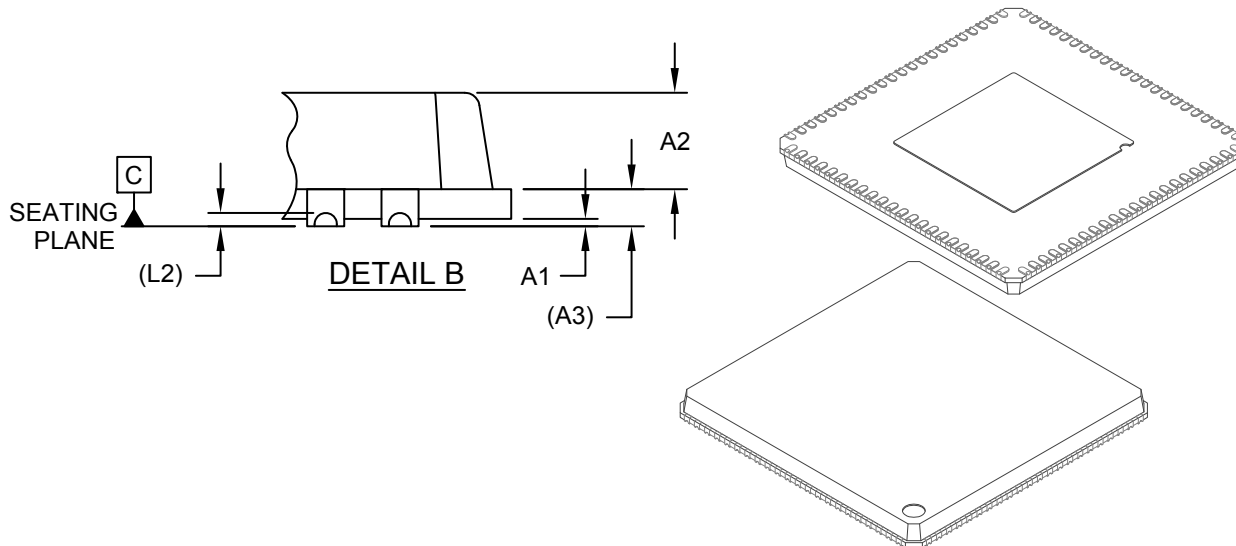

Dimension Limits	Units	MILLIMETERS		
		MIN	NOM	MAX
Number of Terminals	N	88		
Pitch	e	0.50 BSC		
Overall Height	A	0.80	0.85	0.90
Standoff	A1	0.00	0.01	0.05
Mold Cap Height	A2	0.60	0.65	0.70
Base Thickness	A3	0.20 REF		
Overall Length	D	12.00 BSC		
Mold Cap Length	D1	11.75 BSC		
Exposed Pad Length	D2	5.90	6.00	6.10
Overall Width	E	12.00 BSC		
Mold Cap Width	E1	11.75 BSC		
Exposed Pad Width	E2	5.90	6.00	6.10
Terminal Width	b	0.18	0.25	0.30
Dimple Width	b1	0.10	0.15	0.20
Terminal Length	L	0.30	0.40	0.50
Dimple Length	L1	0.05	0.15	0.25
Dimple Height	L2	0.09 REF		
Corner Chamfer	P	0.24	0.42	0.60
Terminal-to-Exposed-Pad	K	2.60 REF		

**Notes:**

1. Pin 1 visual index feature may vary, but must be located within the hatched area.
2. Package is punch singulated
3. Dimensioning and tolerancing per ASME Y14.5M

BSC: Basic Dimension. Theoretically exact value shown without tolerances.

REF: Reference Dimension, usually without tolerance, for information purposes only.



---



---

## Footprint Outlines and Dimensions

---



---

### 88-Lead Very Thin Plastic Quad Flat, No Lead Package (KB) - 12x12x0.9 mm Body [VQFN] Punch Singulated, Wettable Flanks, 6.0x6.0mm Exposed Pad

**Note:** For the most current package drawings, please see the Microchip Packaging Specification located at <http://www.microchip.com/packaging>

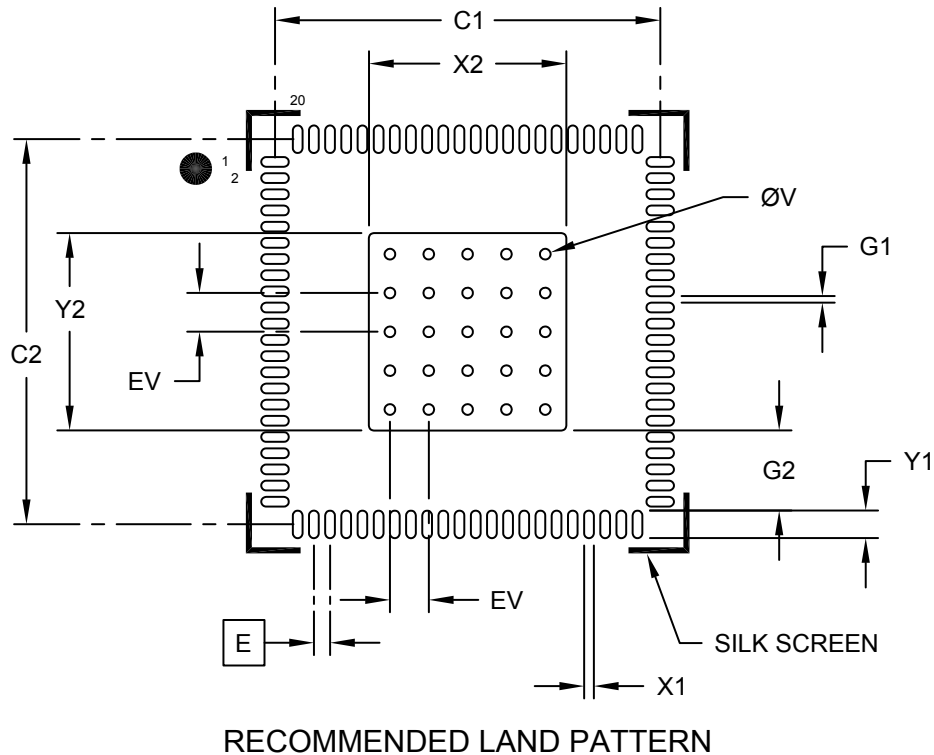

Dimension Limits	Units	MILLIMETERS		
		MIN	NOM	MAX
Contact Pitch	E	0.50 BSC		
Optional Center Pad Width	X2			6.90
Optional Center Pad Length	Y2			6.90
Contact Pad Spacing	C1		11.90	
Contact Pad Spacing	C2		11.90	
Contact Pad Width (X88)	X1			0.30
Contact Pad Length (X88)	Y1			0.80
Contact Pad to Pad (X84)	G1	0.20		
Contact Pad to Center Pad (X88)	G2		2.48	
Thermal Via Diameter	V		0.33	
Thermal Via Pitch	EV		1.20	

**Notes:**

1. Dimensioning and tolerancing per ASME Y14.5M  
BSC: Basic Dimension. Theoretically exact value shown without tolerances.
2. For best soldering results, thermal vias, if used, should be filled or tented to avoid solder loss during reflow process

**Package Outlines and Dimensions**

**100-Lead Very Thin Plastic Quad Flat, No Lead Package (KD) - 12x12 mm Body [VQFN]**

**Note:** For the most current package drawings, please see the Microchip Packaging Specification located at <http://www.microchip.com/packaging>

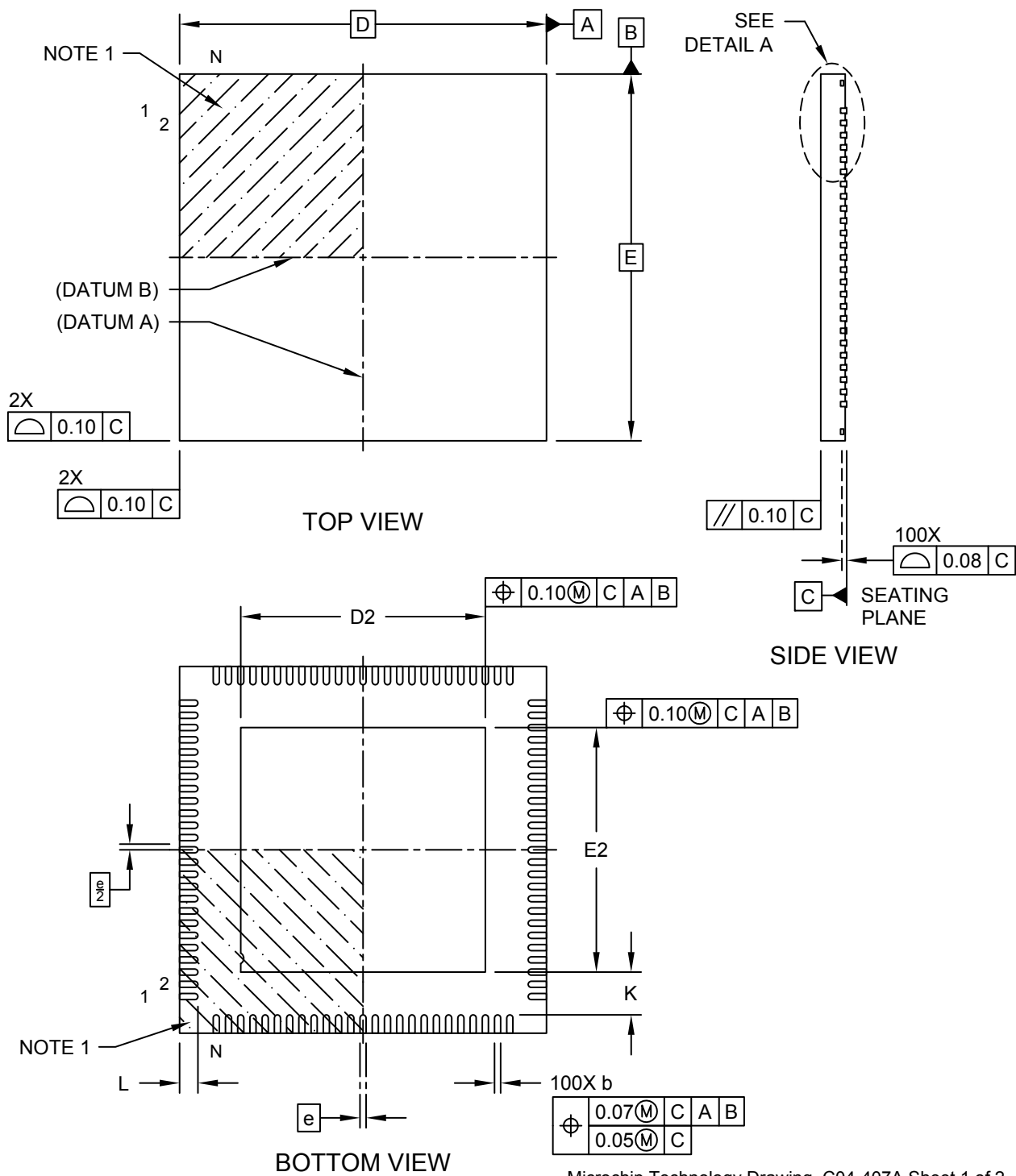

---



---

## Package Outlines and Dimensions

---



---

### 100-Lead Very Thin Plastic Quad Flat, No Lead Package (KD) - 12x12 mm Body [VQFN]

**Note:** For the most current package drawings, please see the Microchip Packaging Specification located at <http://www.microchip.com/packaging>

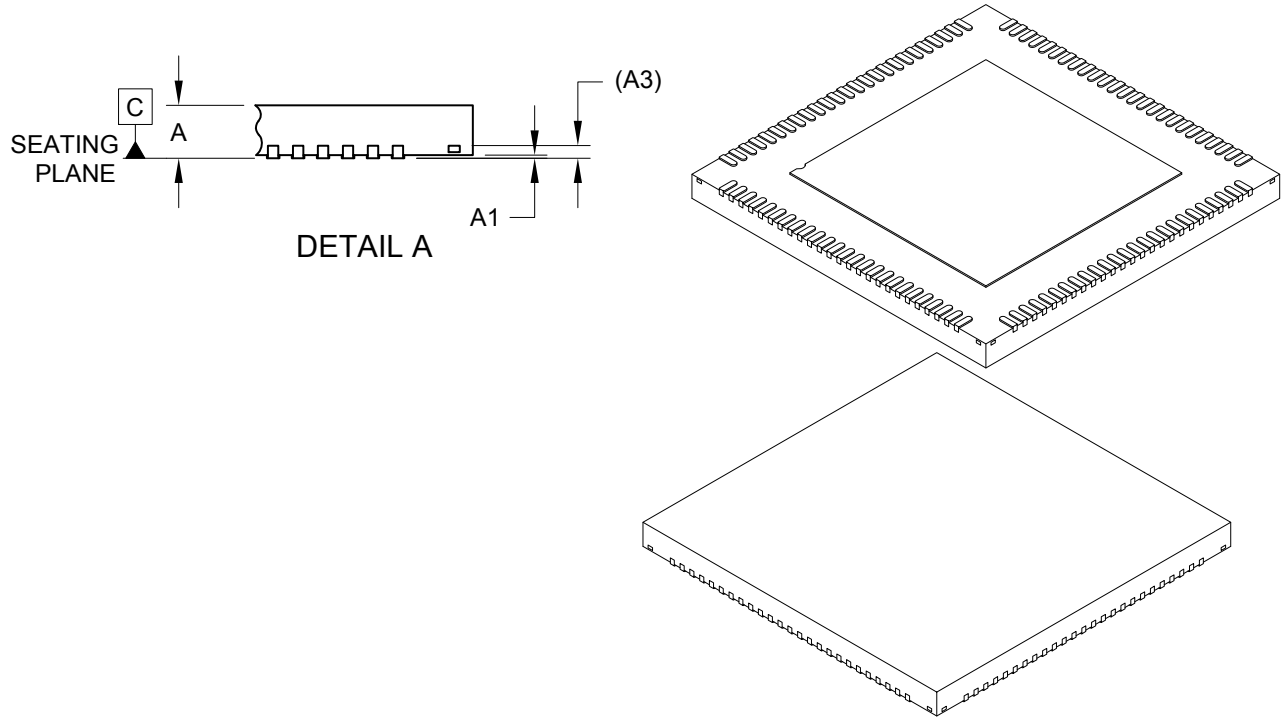

		Units	MILLIMETERS		
Dimension Limits			MIN	NOM	MAX
Number of Terminals	N		100		
Pitch	e		0.40 BSC		
Overall Height	A	0.80	0.85	0.90	
Standoff	A1	0.00	0.02	0.05	
Terminal Thickness	A3	0.203 REF			
Overall Length	D	12.00 BSC			
Exposed Pad Length	D2	7.90	8.00	8.10	
Overall Width	E	12.00 BSC			
Exposed Pad Width	E2	7.90	8.00	8.10	
Terminal Width	b	0.15	0.20	0.25	
Terminal Length	L	0.50	0.60	0.70	
Terminal-to-Exposed-Pad	K	1.30	-	-	

**Notes:**

1. Pin 1 visual index feature may vary, but must be located within the hatched area.
2. Package is saw singulated
3. Dimensioning and tolerancing per ASME Y14.5M

BSC: Basic Dimension. Theoretically exact value shown without tolerances.

REF: Reference Dimension, usually without tolerance, for information purposes only.

**Footprint Outlines and Dimensions**

**100-Lead Very Thin Plastic Quad Flat, No Lead Package (KD) - 12x12 mm Body [VQFN]**

**Note:** For the most current package drawings, please see the Microchip Packaging Specification located at <http://www.microchip.com/packaging>

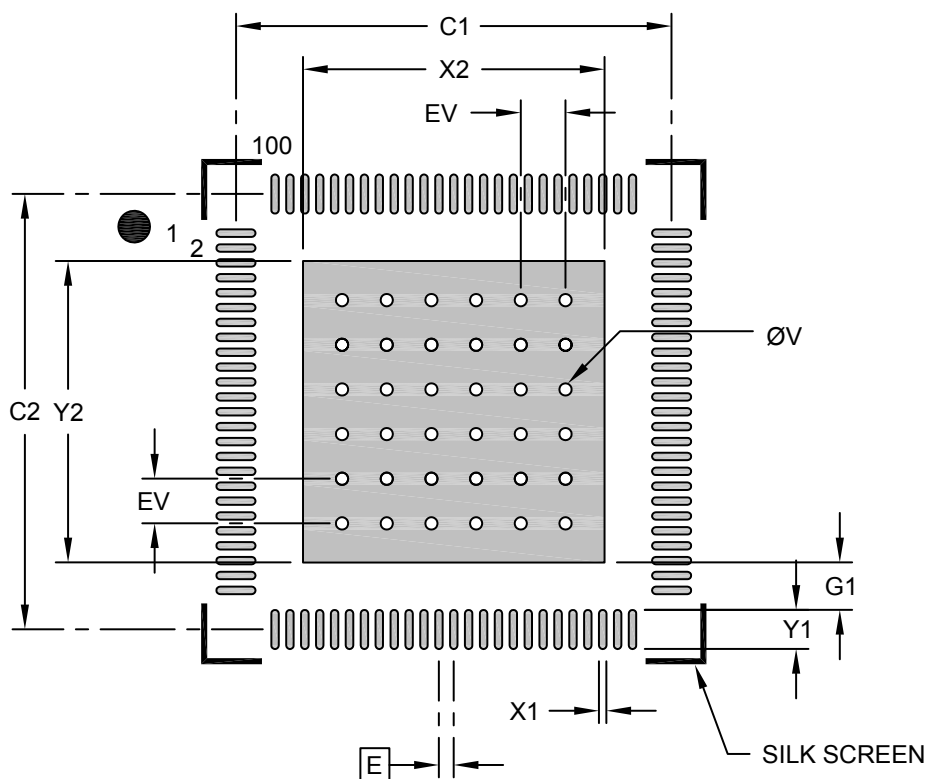

**RECOMMENDED LAND PATTERN**

Dimension Limits	Units	MILLIMETERS		
		MIN	NOM	MAX
Contact Pitch	E	0.40 BSC		
Optional Center Pad Width	X2			8.10
Optional Center Pad Length	Y2			8.10
Contact Pad Spacing	C1		11.70	
Contact Pad Spacing	C2		11.70	
Contact Pad Width (X100)	X1			0.20
Contact Pad Length (X100)	Y1			1.05
Contact Pad to Center Pad (X100)	G1	0.20		
Thermal Via Diameter	V		0.33	
Thermal Via Pitch	EV		1.20	

**Notes:**

1. Dimensioning and tolerancing per ASME Y14.5M  
BSC: Basic Dimension. Theoretically exact value shown without tolerances.
2. For best soldering results, thermal vias, if used, should be filled or tented to avoid solder loss during reflow process

## Package Outlines and Dimensions

### 132-Lead Very Thin Plastic Quad Flat, No Lead Package (NX) - 10x10x0.9 mm Body [VQFN] Dual Row Terminals, Punch Singulated

**Note:** For the most current package drawings, please see the Microchip Packaging Specification located at <http://www.microchip.com/packaging>

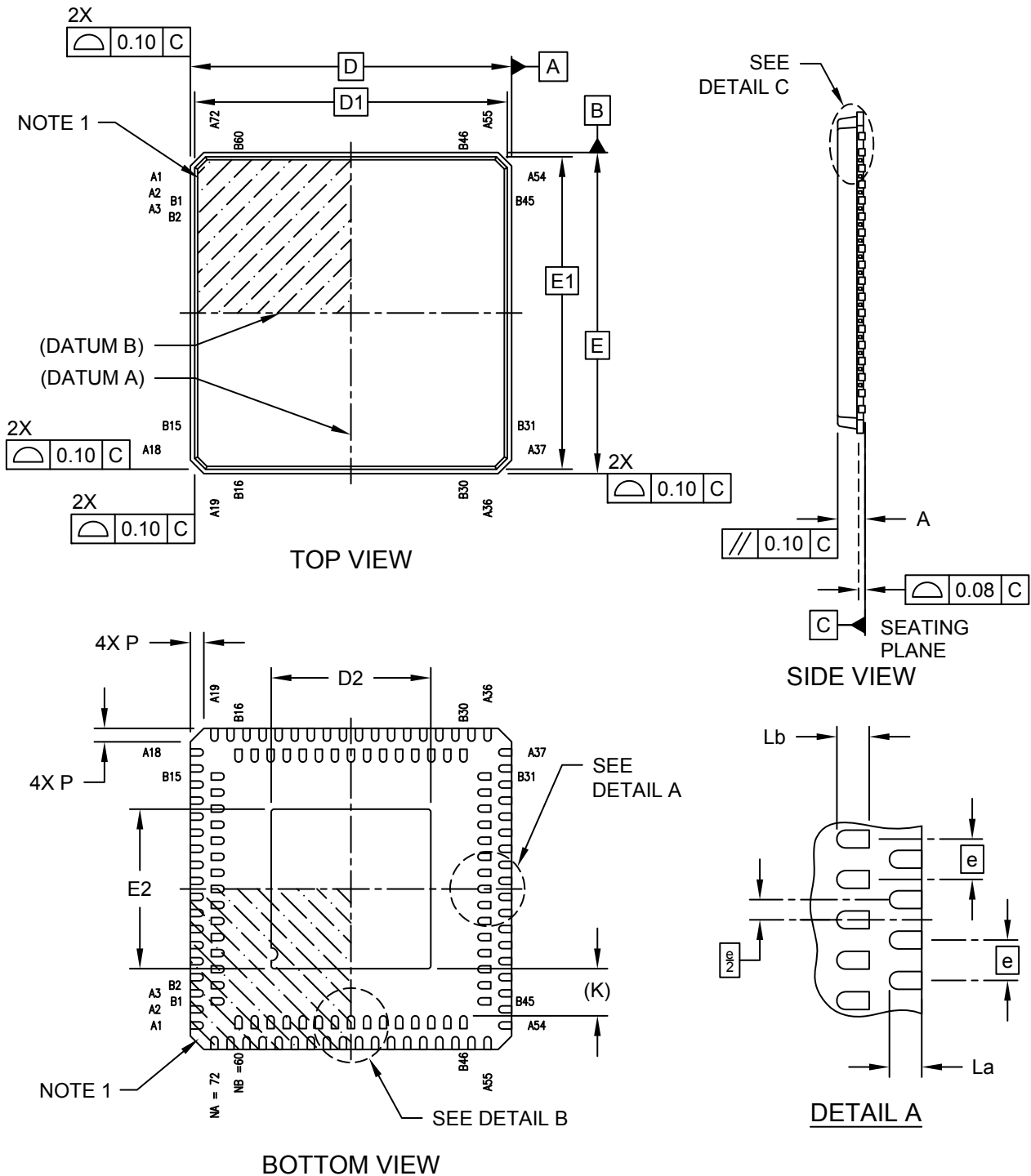

**Package Outlines and Dimensions**

**132-Lead Very Thin Plastic Quad Flat, No Lead Package (NX) - 10x10x0.9 mm Body [VQFN] Dual Row Terminals, Punch Singulated**

**Note:** For the most current package drawings, please see the Microchip Packaging Specification located at <http://www.microchip.com/packaging>

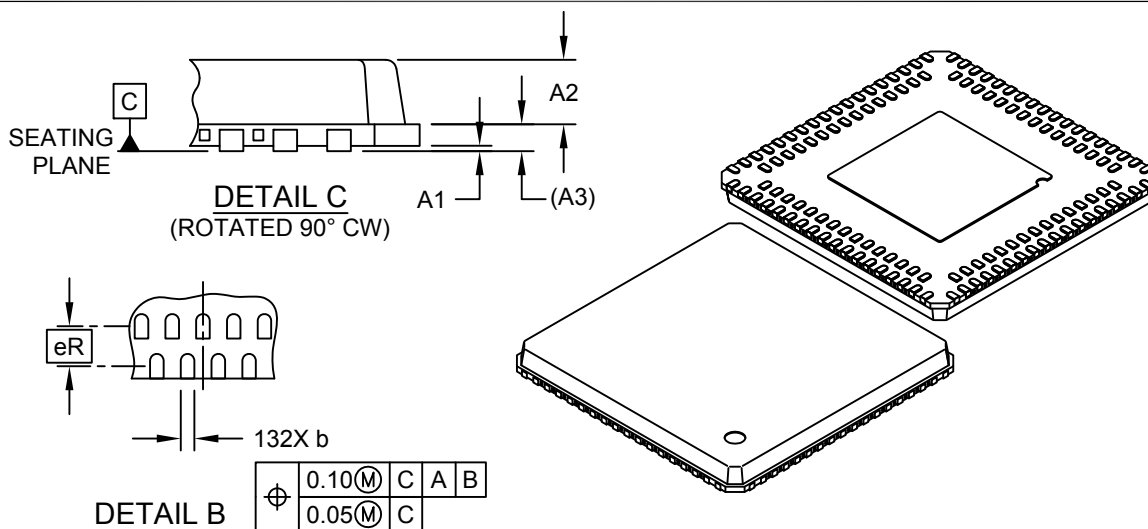

Dimension Limits	Units	MILLIMETERS		
		MIN	NOM	MAX
Number of Terminals	N	132		
Terminals in Outer Row A	NA	72		
Terminals in Inner Row B	NB	60		
Pitch	e	0.50 BSC		
Pitch Between Rows	eR	0.65 BSC		
Overall Height	A	0.80	0.85	0.90
Standoff	A1	0.00	0.01	0.05
Mold Cap Height	A2	0.55	0.60	0.65
Base Thickness	A3	0.25 REF		
Overall Length	D	10.00 BSC		
Mold Cap Length	D1	9.73 BSC		
Exposed Pad Length	D2	4.87	4.97	5.07
Overall Width	E	10.00 BSC		
Mold Cap Width	E1	9.73 BSC		
Exposed Pad Width	E2	4.87	4.97	5.07
Terminal Length, Outer Row	La	0.30	0.40	0.50
Terminal Length, Inner Row	Lb	0.30	0.40	0.50
Terminal Width	b	0.18	0.22	0.30
Terminal-to-Exposed-Pad	K	0.20 MIN REF		
Corner Chamfer	P	0.24	0.42	0.60

**Notes:**

1. Pin 1 visual index feature may vary, but must be located within the hatched area.
2. Package is punch singulated
3. Dimensioning and tolerancing per ASME Y14.5M

BSC: Basic Dimension. Theoretically exact value shown without tolerances.

REF: Reference Dimension, usually without tolerance, for information purposes only.

## Footprint Outlines and Dimensions

### 132-Lead Very Thin Plastic Quad Flat, No Lead Package (NX) - 10x10x0.9 mm Body [VQFN] Dual Row Terminals, Punch Singulated

**Note:** For the most current package drawings, please see the Microchip Packaging Specification located at <http://www.microchip.com/packaging>

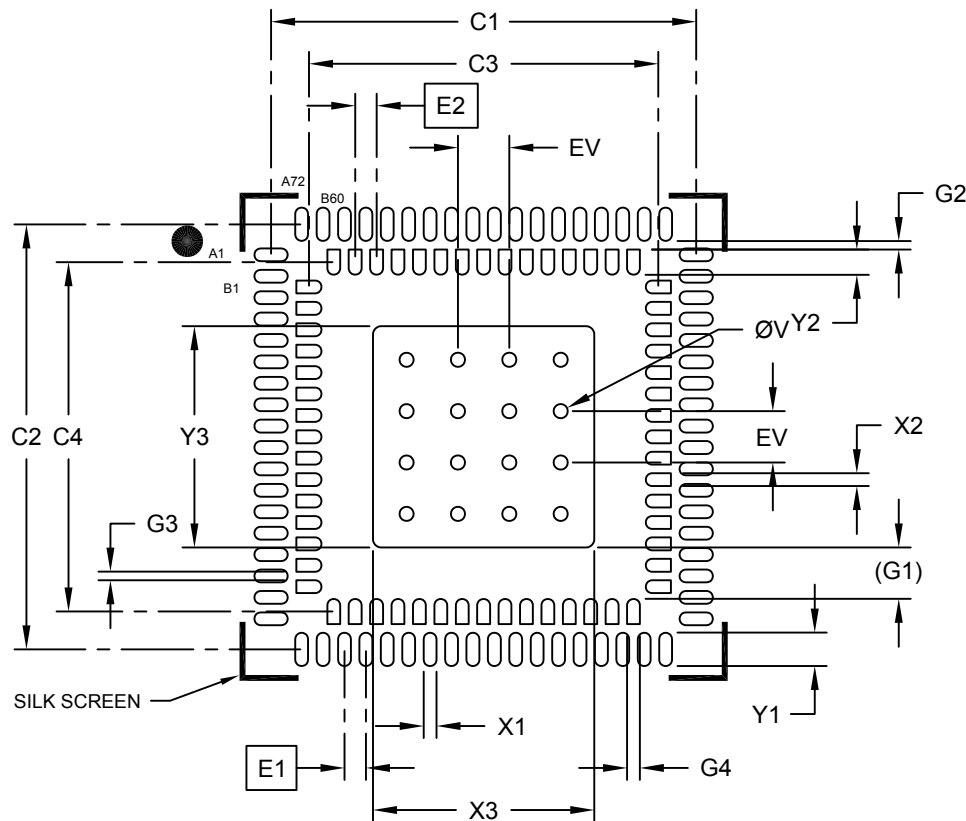

#### RECOMMENDED LAND PATTERN

Units		MILLIMETERS			Units		MILLIMETERS		
Dimension Limits		MIN	NOM	MAX	Dimension Limits		MIN	NOM	MAX
Outer Contact Pitch	E1	0.50 BSC			Inner Contact Pad Spacing	C4	8.16		
Inner Contact Pitch	E2	0.50 BSC			Outer Contact Pad Length (X72)	Y1	0.78		
Outer Contact Pad Width (X72)	X1	0.30			Inner Contact Pad Length (X60)	Y2	0.59		
Inner Contact Pad Width (X60)	X2	0.30			Contact Pad to Center Pad (X60)	G1	1.20 REF		
Optional Center Pad Width	X3	5.17			Inner Pad Row to Outer Pad Row	G2	0.20		
Optional Center Pad Length	Y3	5.17			Contact Pad to Contact Pad (X68)	G3	0.20		
Outer Contact Pad Spacing	C1	9.93			Contact Pad to Contact Pad (X56)	G4	0.20		
Outer Contact Pad Spacing	C2	9.93			Thermal Via Diameter	V	0.33		
Inner Contact Pad Spacing	C3	8.16			Thermal Via Pitch	EV	1.20		

**Notes:**

- Dimensioning and tolerancing per ASME Y14.5M  
BSC: Basic Dimension. Theoretically exact value shown without tolerances.  
REF: Reference Dimension. Provided for information only.
- For best soldering results, thermal vias, if used, should be filled or tented to avoid solder loss during reflow process

Microchip Technology Drawing C04-2360A



**MICROCHIP**

---

---

**Package Outlines and Dimensions**

---

---

NOTES:



---

---

**Package Outlines and Dimensions**

---

---

**WQFN**

**Package Outlines and Dimensions**

**16-Lead Very, Very Thin Plastic Quad Flat, No Lead Package (NGA) - 3x3 mm Body [WQFN] with 1.5x1.5 mm Exposed Pad**

**Note:** For the most current package drawings, please see the Microchip Packaging Specification located at <http://www.microchip.com/packaging>

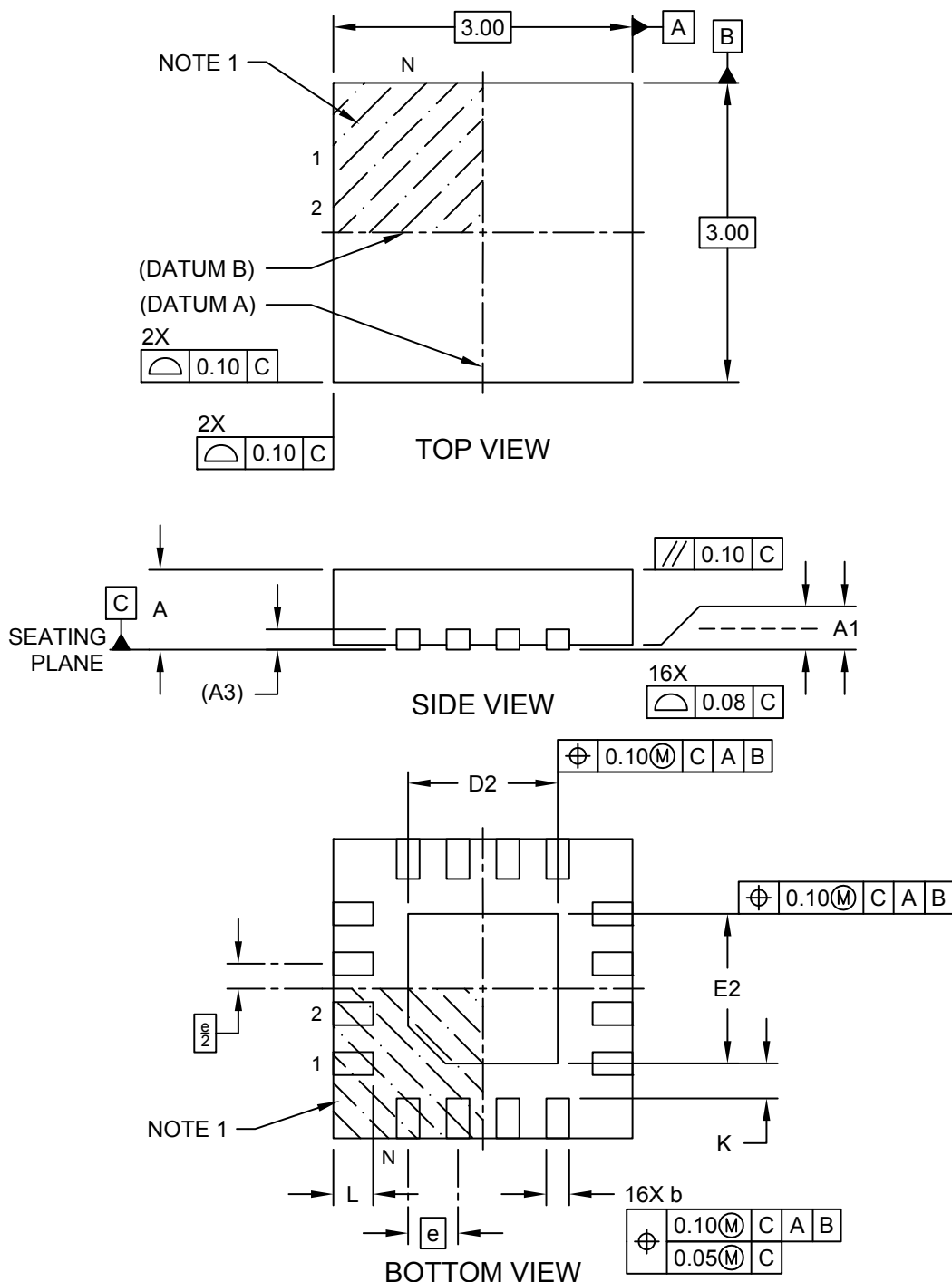

---



---

## Package Outlines and Dimensions

---



---

### 16-Lead Very, Very Thin Plastic Quad Flat, No Lead Package (NGA) - 3x3 mm Body [WQFN] with 1.5x1.5 mm Exposed Pad

**Note:** For the most current package drawings, please see the Microchip Packaging Specification located at <http://www.microchip.com/packaging>

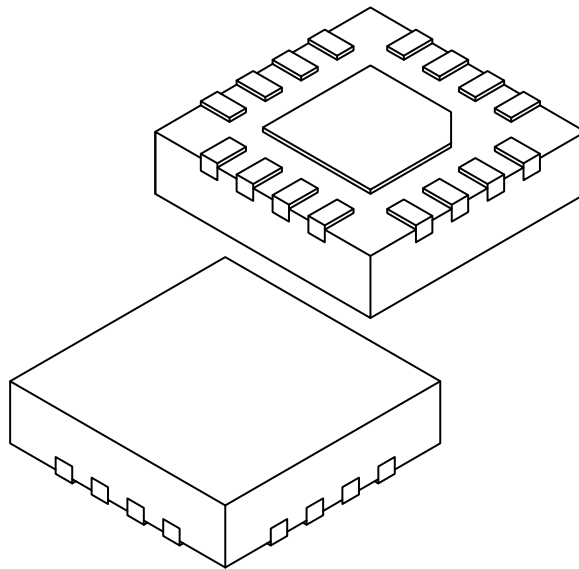

		Units	MILLIMETERS		
Dimension Limits			MIN	NOM	MAX
Number of Terminals	N		16		
Pitch	e		0.50 BSC		
Overall Height	A	0.70	0.75	0.80	
Standoff	A1	0.00	0.02	0.05	
Terminal Thickness	A3	0.203 REF			
Overall Length	D	3.00 BSC			
Exposed Pad Length	D2	1.40	1.50	1.60	
Overall Width	E	3.00 BSC			
Exposed Pad Width	E2	1.40	1.50	1.60	
Terminal Width	b	0.18	0.23	0.30	
Terminal Length	L	0.30	0.40	0.50	
Terminal-to-Exposed-Pad	K	0.20	-	-	

1. Pin 1 visual index feature may vary, but must be located within the hatched area.
2. Package is saw singulated
3. Dimensioning and tolerancing per ASME Y14.5M

BSC: Basic Dimension. Theoretically exact value shown without tolerances.

REF: Reference Dimension, usually without tolerance, for information purposes only.

**Footprint Outlines and Dimensions**

**16-Lead Very, Very Thin Plastic Quad Flat, No Lead Package (NGA) - 3x3 mm Body [WQFN] with 1.5x1.5 mm Exposed Pad**

**Note:** For the most current package drawings, please see the Microchip Packaging Specification located at <http://www.microchip.com/packaging>

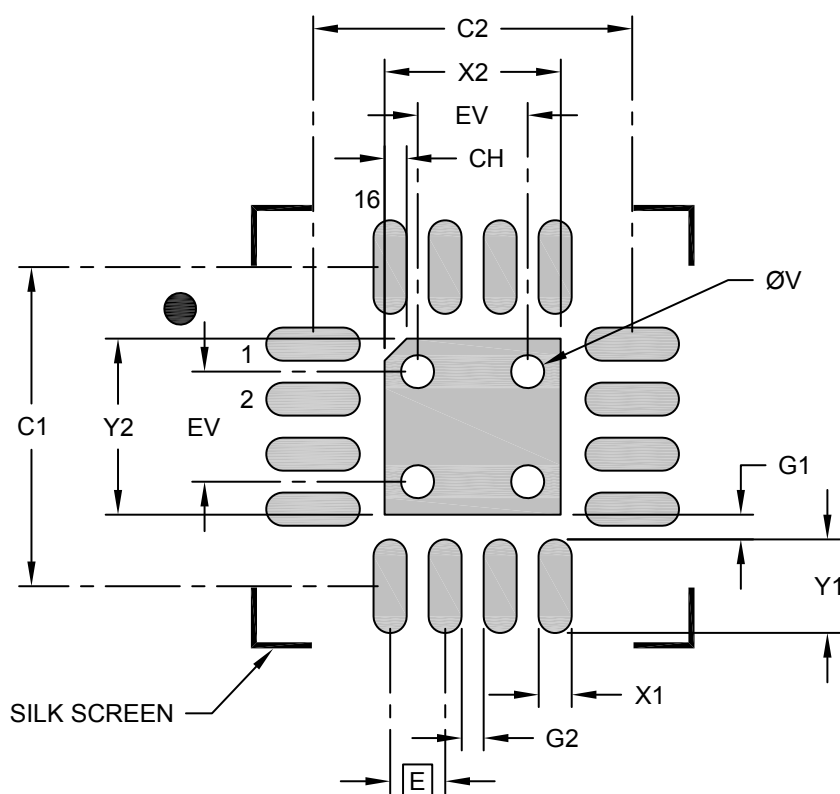

**RECOMMENDED LAND PATTERN**

Dimension	Units	MILLIMETERS		
	Dimension Limits	MIN	NOM	MAX
Contact Pitch	E	0.50 BSC		
Center Pad Width	X2			1.60
Center Pad Length	Y2			1.60
Center Pad Chamfer	CH			0.20
Contact Pad Spacing	C1		2.90	
Contact Pad Spacing	C2		2.90	
Contact Pad Width (X16)	X1			0.30
Contact Pad Length (X16)	Y1			0.85
Contact Pad to Center Pad (X16)	G1	0.23		
Contact Pad to Contact Pad (X12)	G2	0.20		
Thermal Via Diameter	V		0.30	
Thermal Via Pitch	EV		1.00	

**Notes:**

1. Dimensioning and tolerancing per ASME Y14.5M  
BSC: Basic Dimension. Theoretically exact value shown without tolerances.
2. For best soldering results, thermal vias, if used, should be filled or tented to avoid solder loss during reflow process

---

---

**Package Outlines and Dimensions**

---

---

**XQFN**

**Package Outlines and Dimensions**

**16-Lead Extremely Thin Quad Flat, No Lead Package (NL) - 3x3x0.5mm Body [XQFN]**

**Note:** For the most current package drawings, please see the Microchip Packaging Specification located at <http://www.microchip.com/packaging>

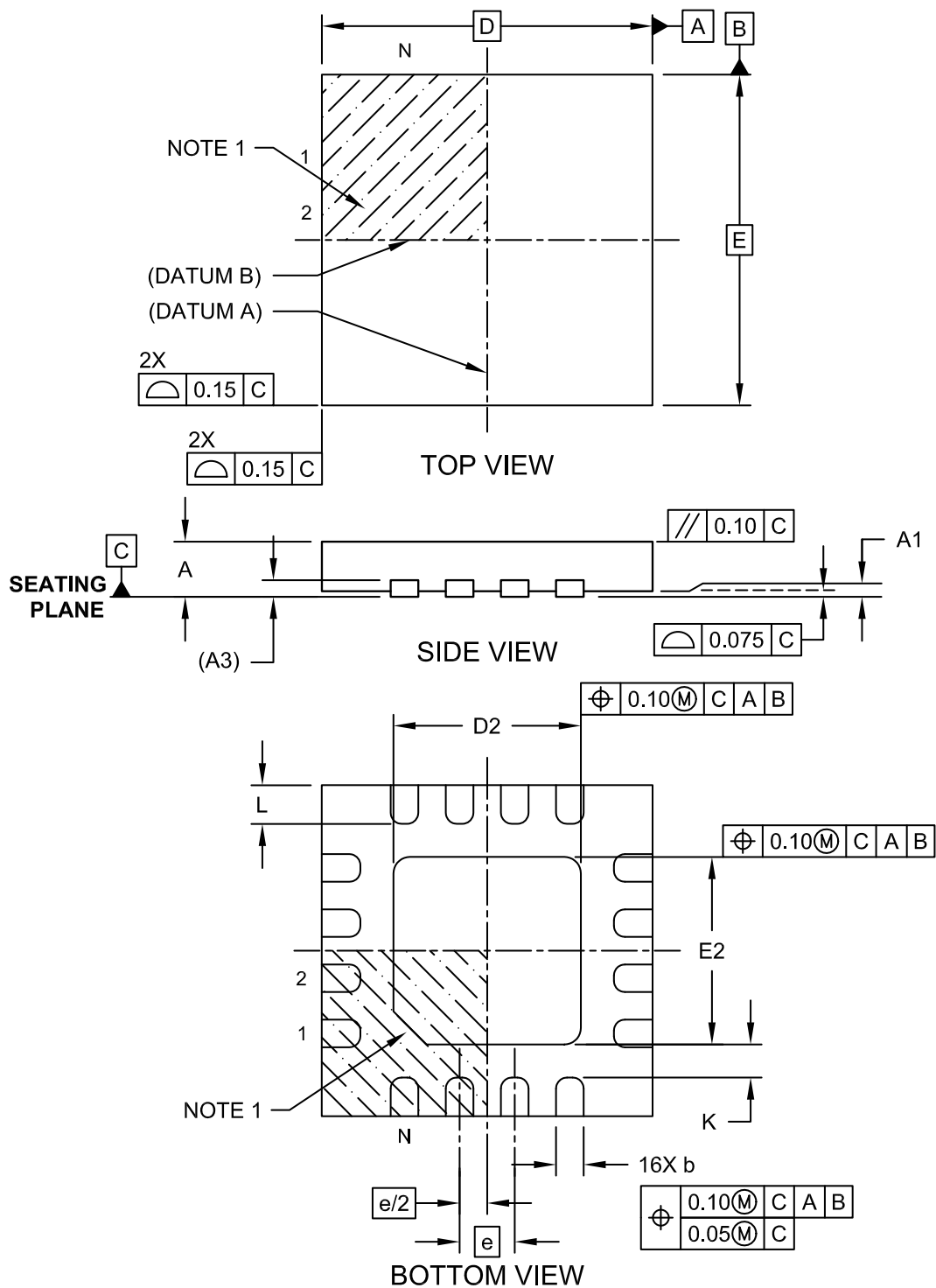

---



---

## Package Outlines and Dimensions

---



---

### 16-Lead Extremely Thin Quad Flat, No Lead Package (NL) - 3x3x0.5mm Body [XQFN]

**Note:** For the most current package drawings, please see the Microchip Packaging Specification located at <http://www.microchip.com/packaging>

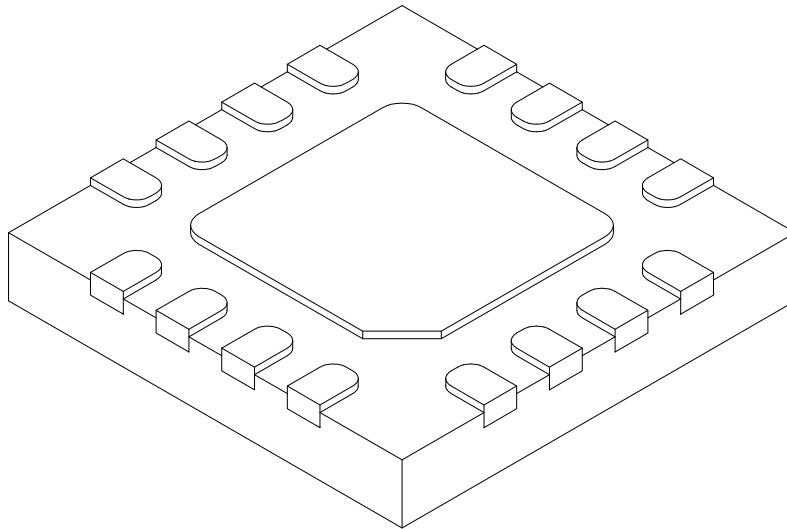

		Units	MILLIMETERS		
Dimension Limits			MIN	NOM	MAX
Number of Terminals	N		16		
Pitch	e		0.50 BSC		
Overall Height	A		0.40	0.45	0.50
Standoff	A1		0.00	0.02	0.05
Terminal Thickness	A3		0.15 REF		
Overall Width	E		3.00 BSC		
Exposed Pad Width	E2		1.65	1.70	1.75
Overall Length	D		3.00 BSC		
Exposed Pad Length	D2		1.65	1.70	1.75
Terminal Width	b		0.20	0.25	0.30
Terminal Length	L		0.30	0.35	0.40
Terminal-to-Exposed-Pad	K		0.20	-	-

**Notes:**

1. Pin 1 visual index feature may vary, but must be located within the hatched area.
2. Package is saw singulated
3. Dimensioning and tolerancing per ASME Y14.5M

BSC: Basic Dimension. Theoretically exact value shown without tolerances.

REF: Reference Dimension, usually without tolerance, for information purposes only.



**MICROCHIP**

---

---

**Package Outlines and Dimensions**

---

---

NOTES:



---

---

**Package Outlines and Dimensions**

---

---

**X2QFN**

**Package Outlines and Dimensions**

**10-Lead Super-Thin Plastic Quad Flat, No Lead Package (9X) - 1.5x1.5 mm Body [X2QFN]. 0.75x0.75 mm Exposed Pad**

**Note:** For the most current package drawings, please see the Microchip Packaging Specification located at <http://www.microchip.com/packaging>

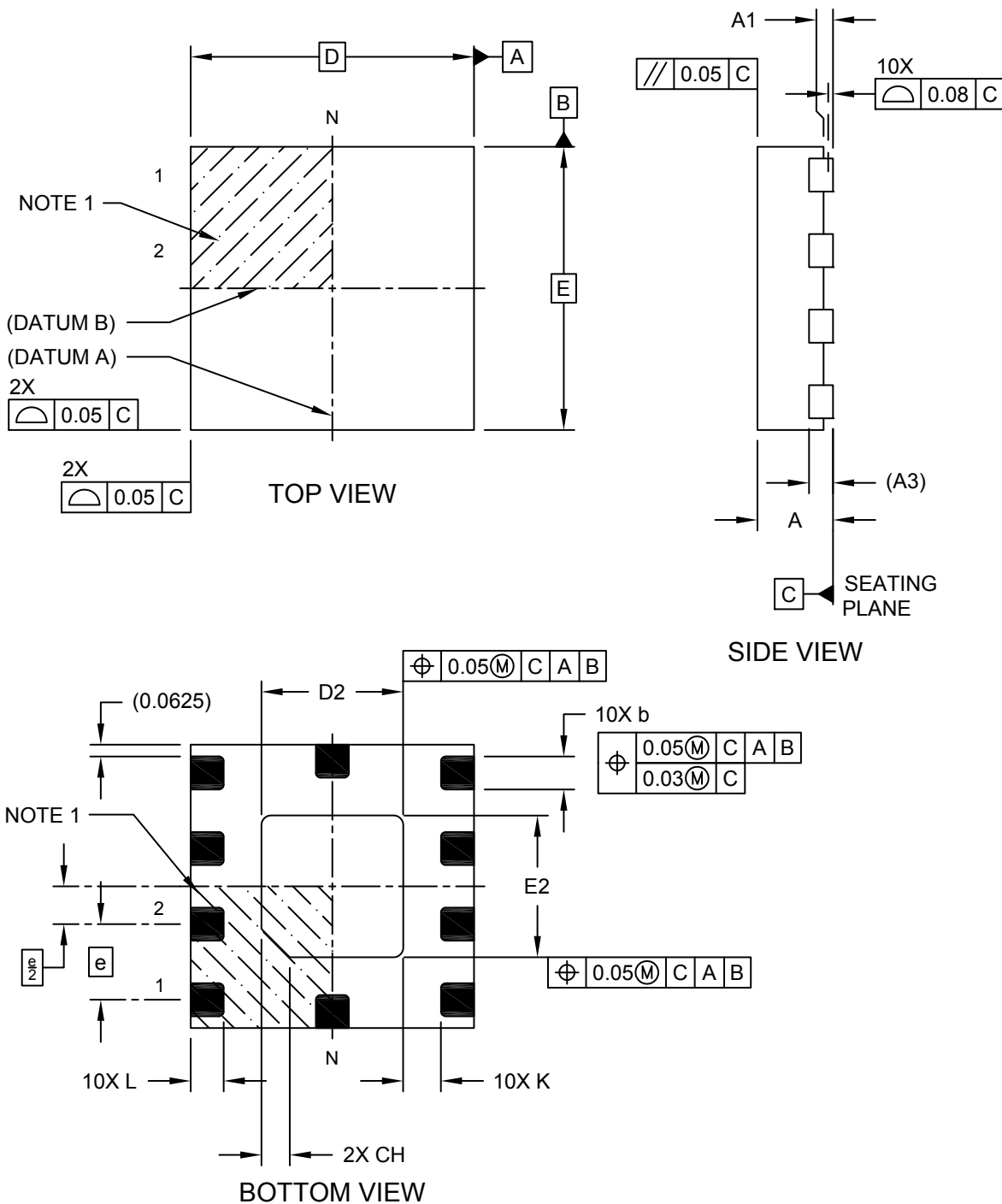

---



---

## Package Outlines and Dimensions

---



---

### 10-Lead Super-Thin Plastic Quad Flat, No Lead Package (9X) - 1.5x1.5 mm Body [X2QFN]. 0.75x0.75 mm Exposed Pad

**Note:** For the most current package drawings, please see the Microchip Packaging Specification located at <http://www.microchip.com/packaging>

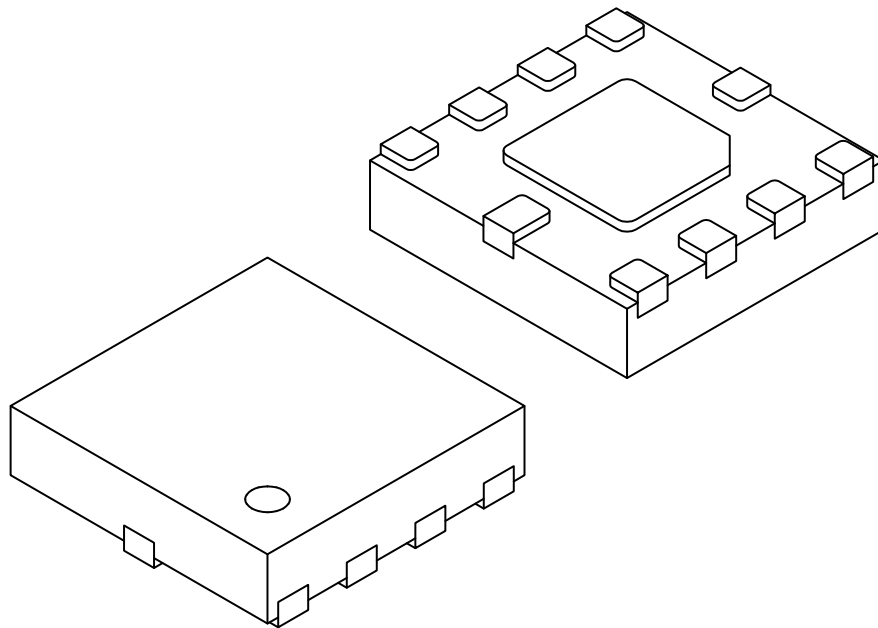

Dimension Limits	Units	MILLIMETERS		
		MIN	NOM	MAX
Number of Terminals	N	10		
Pitch	e	0.40 BSC		
Overall Height	A	0.30	0.35	0.40
Standoff	A1	0.00	0.02	0.05
Terminal Thickness	(A3)	0.127 REF		
Overall Width	E	1.50 BSC		
Exposed Pad Width	E2	0.70	0.75	0.80
Overall Length	D	1.50 BSC		
Exposed Pad Length	D2	0.70	0.75	0.80
Exposed Pad Corner Chamfer	CH	-	0.15	-
Terminal Width	b	0.125	0.175	0.225
Terminal Length	L	0.125	0.175	0.225
Terminal-to-Exposed-Pad	K	0.20	-	-

**Notes:**

1. Pin 1 visual index feature may vary, but must be located within the hatched area.
2. Package is saw singulated
3. Dimensioning and tolerancing per ASME Y14.5M
  - BSC: Basic Dimension. Theoretically exact value shown without tolerances.
  - REF: Reference Dimension, usually without tolerance, for information purposes only.

**Footprint Outlines and Dimensions**

**10-Lead Super-Thin Plastic Quad Flat, No Lead Package (9X) - 1.5x1.5 mm Body [X2QFN]. 0.75x0.75 mm Exposed Pad**

**Note:** For the most current package drawings, please see the Microchip Packaging Specification located at <http://www.microchip.com/packaging>

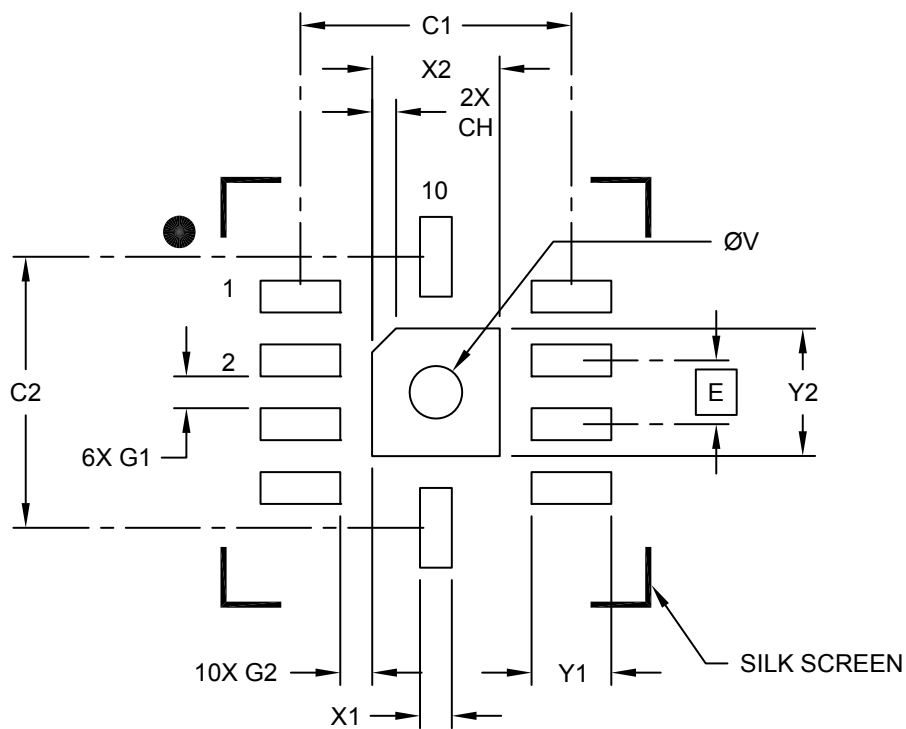

**RECOMMENDED LAND PATTERN**

Dimension Limits	Units	MILLIMETERS		
		MIN	NOM	MAX
Contact Pitch	E	0.40 BSC		
Optional Center Pad Width	X2			0.80
Optional Center Pad Length	Y2			0.80
Optional Center Pad Corner Chamfer	CH		0.15	
Contact Pad Spacing	C1		1.70	
Contact Pad Spacing	C2		1.70	
Contact Pad Width (X10)	X1			0.20
Contact Pad Length (X10)	Y1			0.50
Contact Pad to Pad (X6)	G1	0.20		
Contact Pad to Center Pad (X10)	G2	0.20		
Thermal Via Diameter	V		0.33	

Notes:

- Dimensioning and tolerancing per ASME Y14.5M  
BSC: Basic Dimension. Theoretically exact value shown without tolerances.
- For best soldering results, thermal vias, if used, should be filled or tented to avoid solder loss during reflow process

**Package Outlines and Dimensions**

**16-Lead Super Thin Plastic Quad Flat, No Lead Package (NT) - 2.5x2.5 mm Body [X2QFN]; SST Legacy Package (Q3CE/F)**

**Note:** For the most current package drawings, please see the Microchip Packaging Specification located at <http://www.microchip.com/packaging>

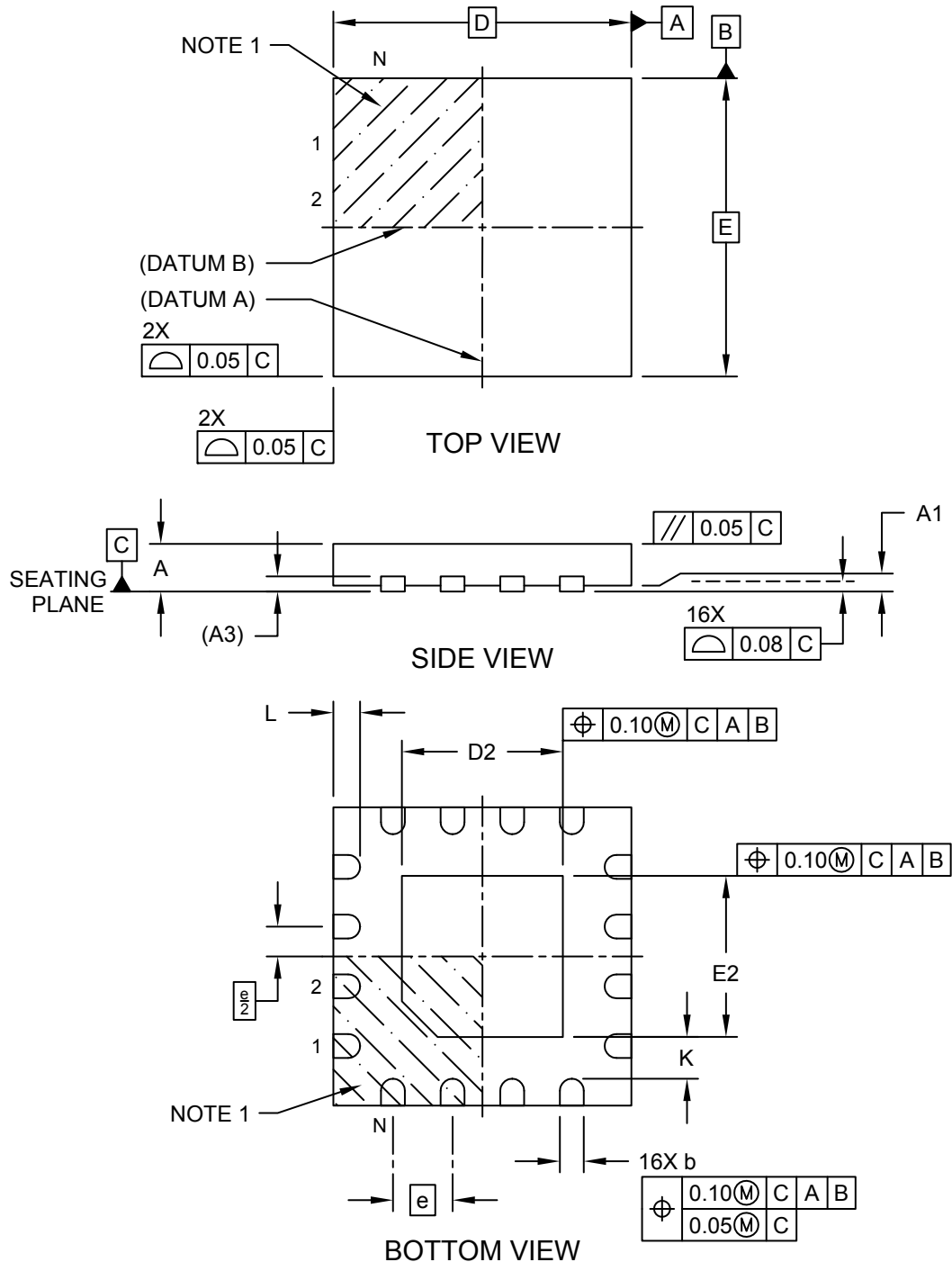

**Package Outlines and Dimensions**

**16-Lead Super Thin Plastic Quad Flat, No Lead Package (NT) - 2.5x2.5 mm Body [X2QFN]; SST Legacy Package (Q3CE/F)**

**Note:** For the most current package drawings, please see the Microchip Packaging Specification located at <http://www.microchip.com/packaging>

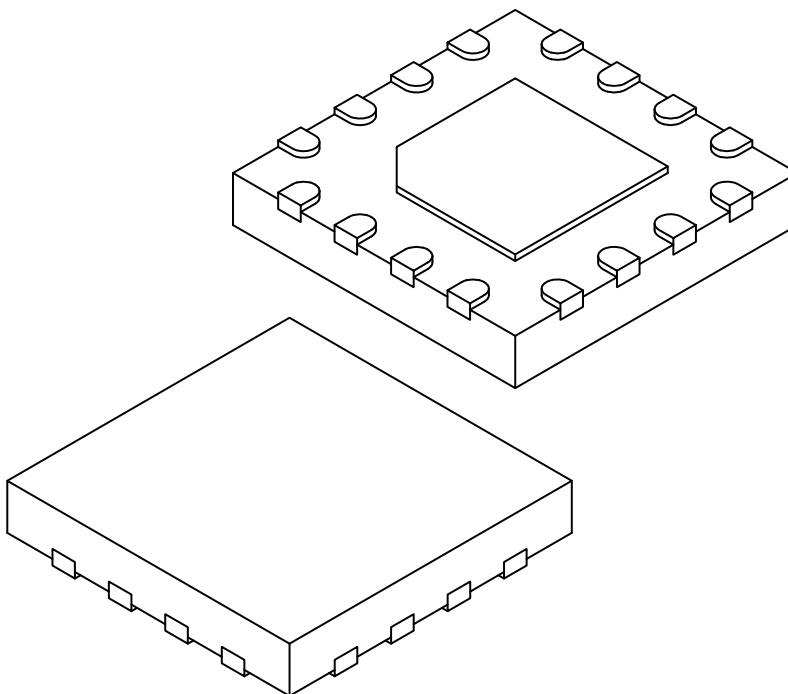

Dimension Limits	Units	MILLIMETERS		
		MIN	NOM	MAX
Number of Terminals	N	16		
Pitch	e	0.50 BSC		
Overall Height	A	0.34	0.37	0.40
Standoff	A1	0.00	0.02	0.05
Terminal Thickness	A3	0.127 REF		
Overall Length	D	2.50 BSC		
Exposed Pad Length	D2	1.25	1.35	1.45
Overall Width	E	2.50 BSC		
Exposed Pad Width	E2	1.25	1.35	1.45
Terminal Width	b	0.15	0.20	0.25
Terminal Length	L	0.175	0.225	0.275
Terminal-to-Exposed-Pad	K	0.20	-	-

**Notes:**

1. Pin 1 visual index feature may vary, but must be located within the hatched area.
2. Package is saw singulated
3. Dimensioning and tolerancing per ASME Y14.5M

BSC: Basic Dimension. Theoretically exact value shown without tolerances.

REF: Reference Dimension, usually without tolerance, for information purposes only.

---



---

## Footprint Outlines and Dimensions

---



---

### 16-Lead Super Thin Plastic Quad Flat, No Lead Package (NT) - 2.5x2.5 mm Body [X2QFN]; SST Legacy Package (Q3CE/F)

**Note:** For the most current package drawings, please see the Microchip Packaging Specification located at <http://www.microchip.com/packaging>

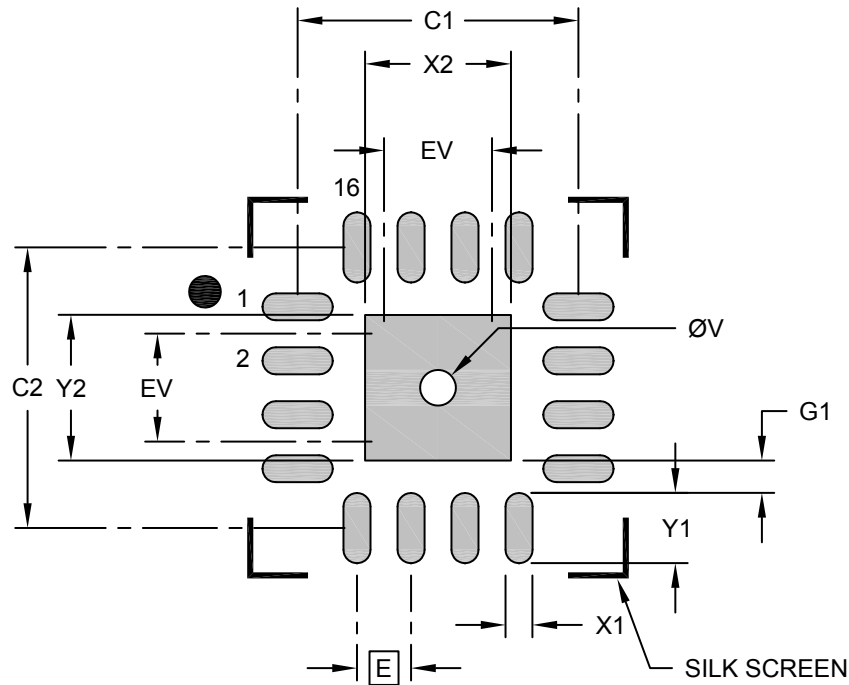

### RECOMMENDED LAND PATTERN

Dimension Limits	Units	MILLIMETERS		
		MIN	NOM	MAX
Contact Pitch	E	0.50 BSC		
Optional Center Pad Width	X2			1.35
Optional Center Pad Length	Y2			1.35
Contact Pad Spacing	C1		2.60	
Contact Pad Spacing	C2		2.60	
Contact Pad Width (X16)	X1			0.25
Contact Pad Length (X16)	Y1			0.65
Contact Pad to Center Pad (X16)	G1	0.20		
Thermal Via Diameter	V		0.33	

**Notes:**

- Dimensioning and tolerancing per ASME Y14.5M  
BSC: Basic Dimension. Theoretically exact value shown without tolerances.
- For best soldering results, thermal vias, if used, should be filled or tented to avoid solder loss during reflow process



**MICROCHIP**

---

---

**Package Outlines and Dimensions**

---

---

NOTES:



---

---

**Package Outlines and Dimensions**

---

---

**WTLA**

**Package Outlines and Dimensions**

**20-Terminal Very, Very Thin Leadless Array Package (TW) – 3x3x0.7 mm Body With Exposed Pad [WTLA]**

**Note:** For the most current package drawings, please see the Microchip Packaging Specification located at <http://www.microchip.com/packaging>

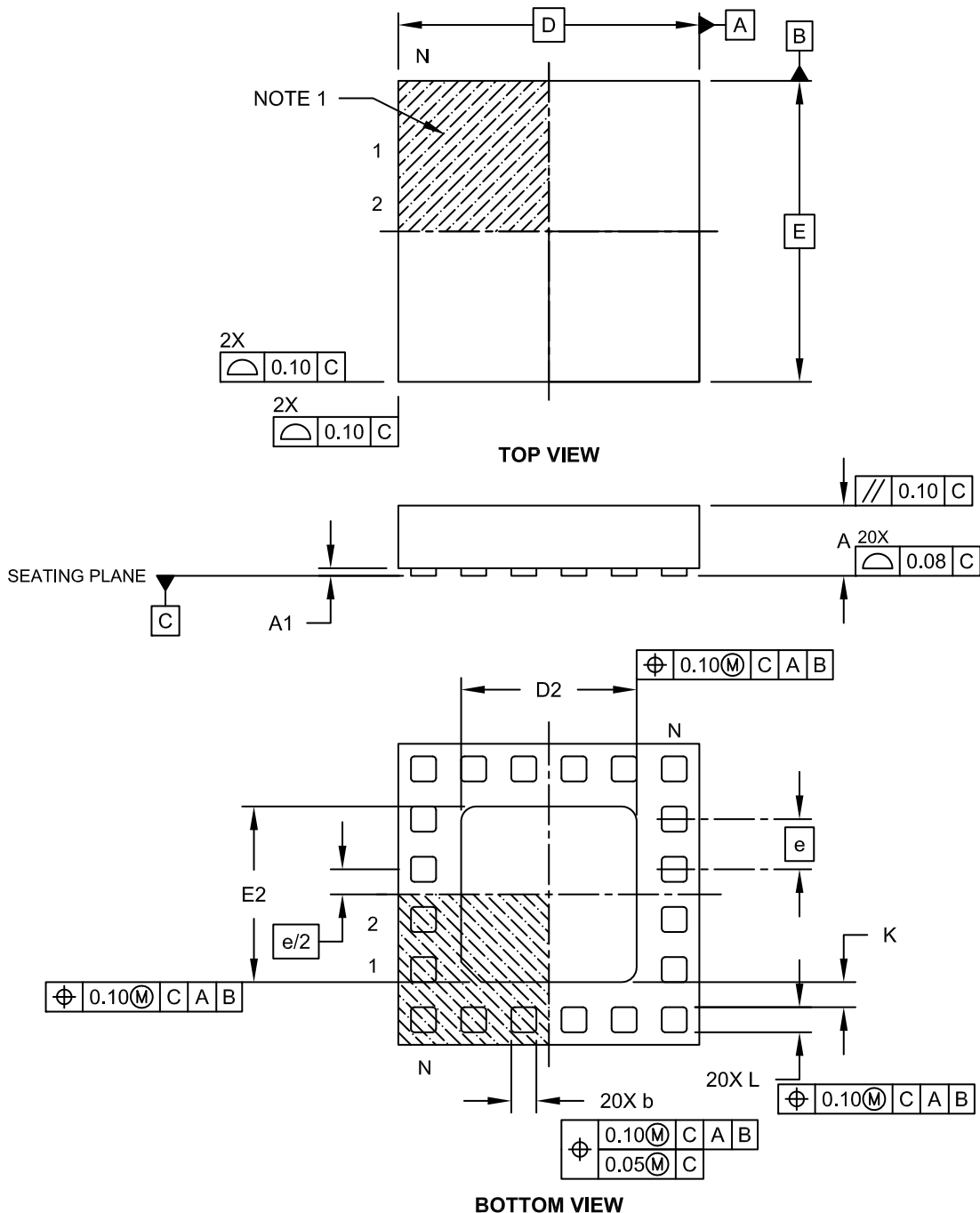

---



---

## Package Outlines and Dimensions

---



---

### 20-Terminal Very, Very Thin Leadless Array Package (TW) – 3x3x0.7 mm Body With Exposed Pad [WTLA]

**Note:** For the most current package drawings, please see the Microchip Packaging Specification located at <http://www.microchip.com/packaging>

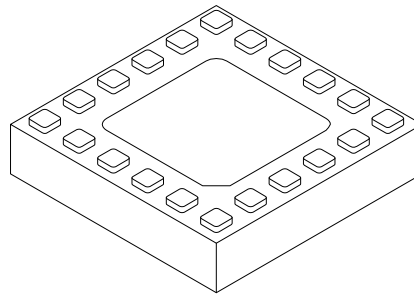

Dimension	Units Limits	MILLIMETERS		
		MIN	NOM	MAX
Number of Pins	N	20		
Pitch	e	0.50 BSC		
Overall Height	A	0.60	-	0.70
Standoff	A1	0.025	-	0.075
Overall Width	E	3.00 BSC		
Exposed Pad Width	E2	1.60	1.75	1.90
Overall Length	D	3.00 BSC		
Exposed Pad Length	D2	1.60	1.75	1.90
Contact Width	b	0.20	0.25	0.30
Contact Length	L	0.20	0.25	0.30
Contact-to-Exposed Pad	K	0.20	-	-

**Notes:**

1. Pin 1 visual index feature may vary, but must be located within the hatched area.
2. Package is saw singulated.
3. Dimensioning and tolerancing per ASME Y14.5M.

BSC: Basic Dimension. Theoretically exact value shown without tolerances.

REF: Reference Dimension, usually without tolerance, for information purposes only.



**MICROCHIP**

---

---

**Package Outlines and Dimensions**

---

---

NOTES:

---

---

**Package Outlines and Dimensions**

---

---

**VTLA**

**Package Outlines and Dimensions**

**36-Terminal Very Thin Thermal Leadless Array Package (TL) – 5x5x0.9 mm Body with Exposed Pad [VTLA]**

**Note:** For the most current package drawings, please see the Microchip Packaging Specification located at <http://www.microchip.com/packaging>

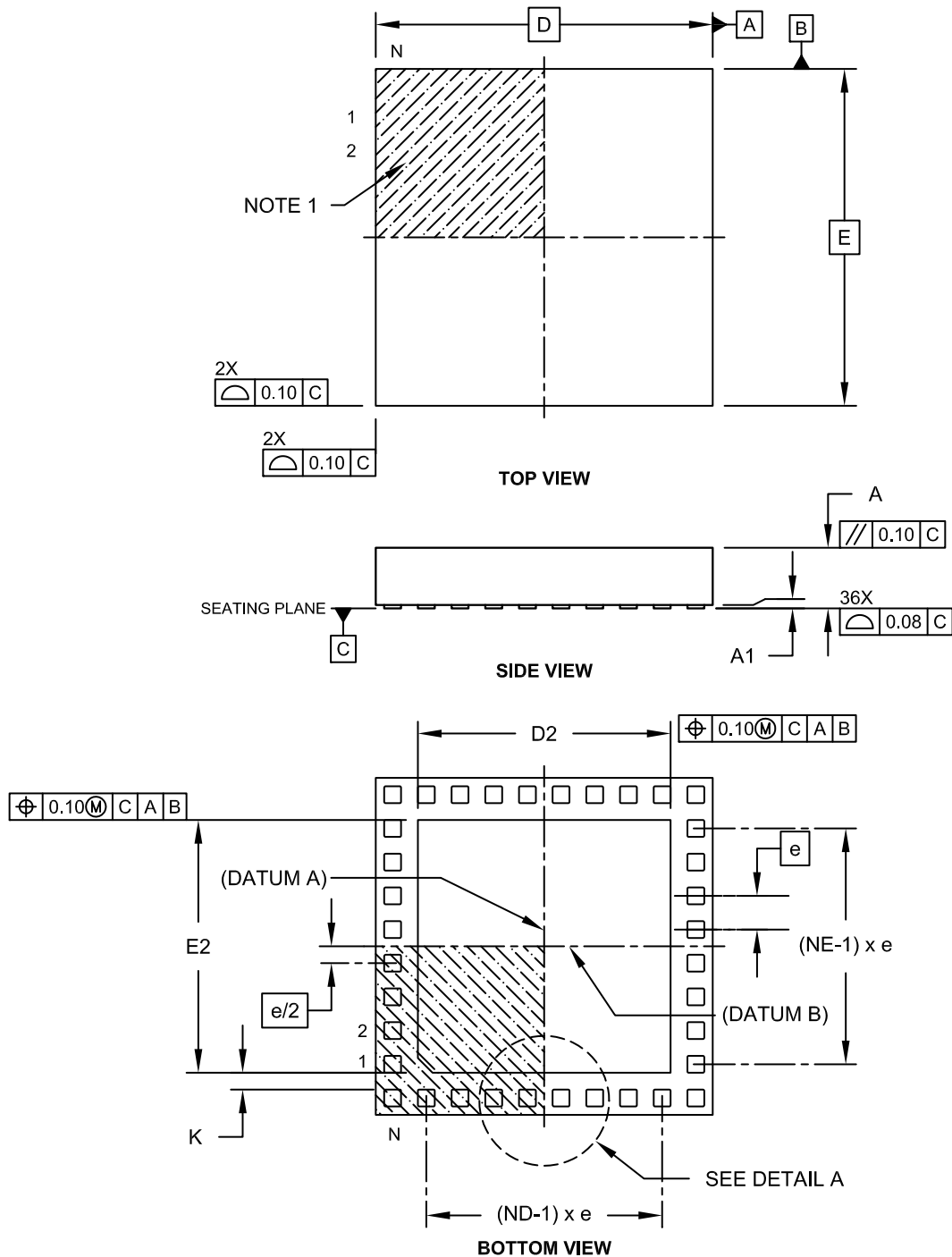

---



---

## Package Outlines and Dimensions

---



---

### 36-Terminal Very Thin Thermal Leadless Array Package (TL) – 5x5x0.9 mm Body with Exposed Pad [VTLA]

**Note:** For the most current package drawings, please see the Microchip Packaging Specification located at <http://www.microchip.com/packaging>

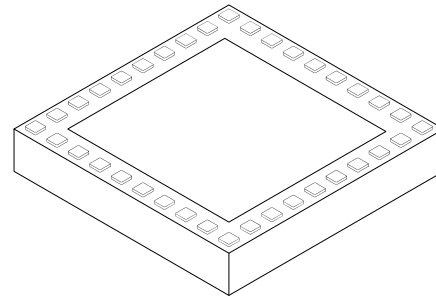
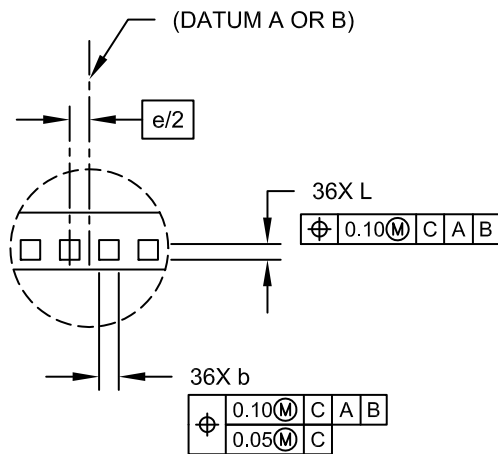

**DETAIL A**

Dimension	Units	MILLIMETERS		
		Limits	MIN	NOM
Number of Pins	N		36	
Number of Pins per Side	ND		10	
Number of Pins per Side	NE		8	
Pitch	e		0.50 BSC	
Overall Height	A	0.80	0.90	1.00
Standoff	A1	0.025	-	0.075
Overall Width	E		5.00 BSC	
Exposed Pad Width	E2	3.60	3.75	3.90
Overall Length	D		5.00 BSC	
Exposed Pad Length	D2	3.60	3.75	3.90
Contact Width	b	0.20	0.25	0.30
Contact Length	L	0.20	0.25	0.30
Contact-to-Exposed Pad	K	0.20	-	-

**Notes:**

1. Pin 1 visual index feature may vary, but must be located within the hatched area.
2. Package is saw singulated.
3. Dimensioning and tolerancing per ASME Y14.5M.

BSC: Basic Dimension. Theoretically exact value shown without tolerances.

REF: Reference Dimension, usually without tolerance, for information purposes only.

**Footprint Outlines and Dimensions**

**36-Lead Thermal Leadless Array Package (TL) – 5x5x0.9 mm Body with Exposed Pad [VTLA]**

**Note:** For the most current package drawings, please see the Microchip Packaging Specification located at <http://www.microchip.com/packaging>

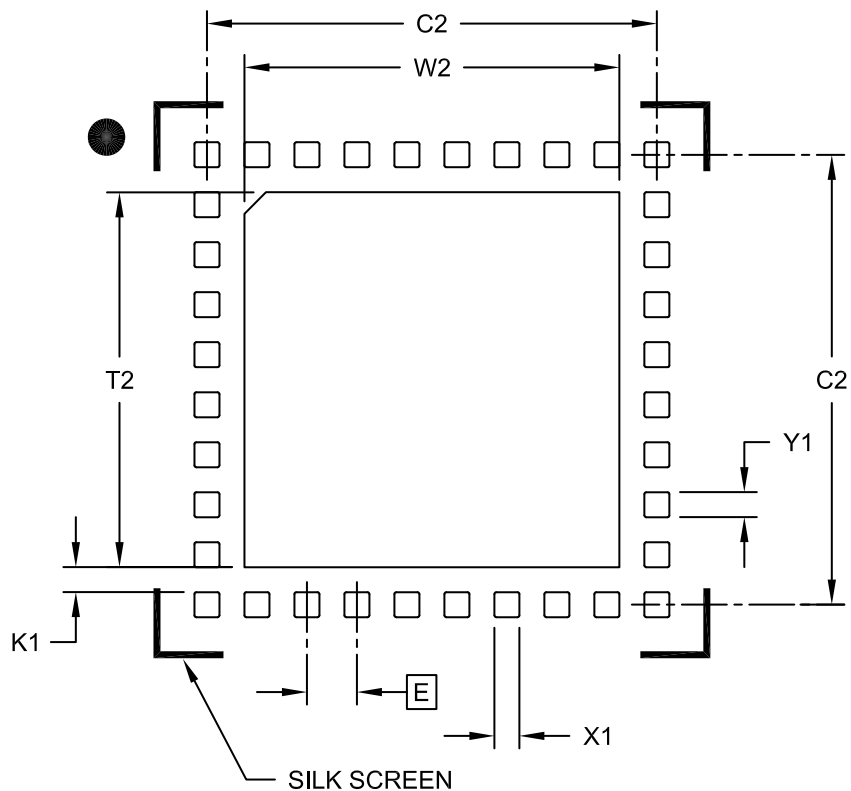

Dimension Limits	Units	MILLIMETERS		
		MIN	NOM	MAX
Contact Pitch	E	0.50 BSC		
Optional Center Pad Width	W2			3.75
Optional Center Pad Length	T2			3.75
Contact Pad Spacing	C1		4.50	
Contact Pad Spacing	C2		4.50	
Contact Pad Width (X36)	X1			0.25
Contact Pad Length (X36)	Y1			0.25
Distance Between Pads	K1	0.15	0.25	

Notes:

1. Dimensioning and tolerancing per ASME Y14.5M  
BSC: Basic Dimension. Theoretically exact value shown without tolerances.



**Package Outlines and Dimensions**

**44-Terminal Very Thin Leadless Array Package (TL) – 6x6x0.9 mm Body  
With Exposed Pad [VTLA]**

**Note:** For the most current package drawings, please see the Microchip Packaging Specification located at <http://www.microchip.com/packaging>

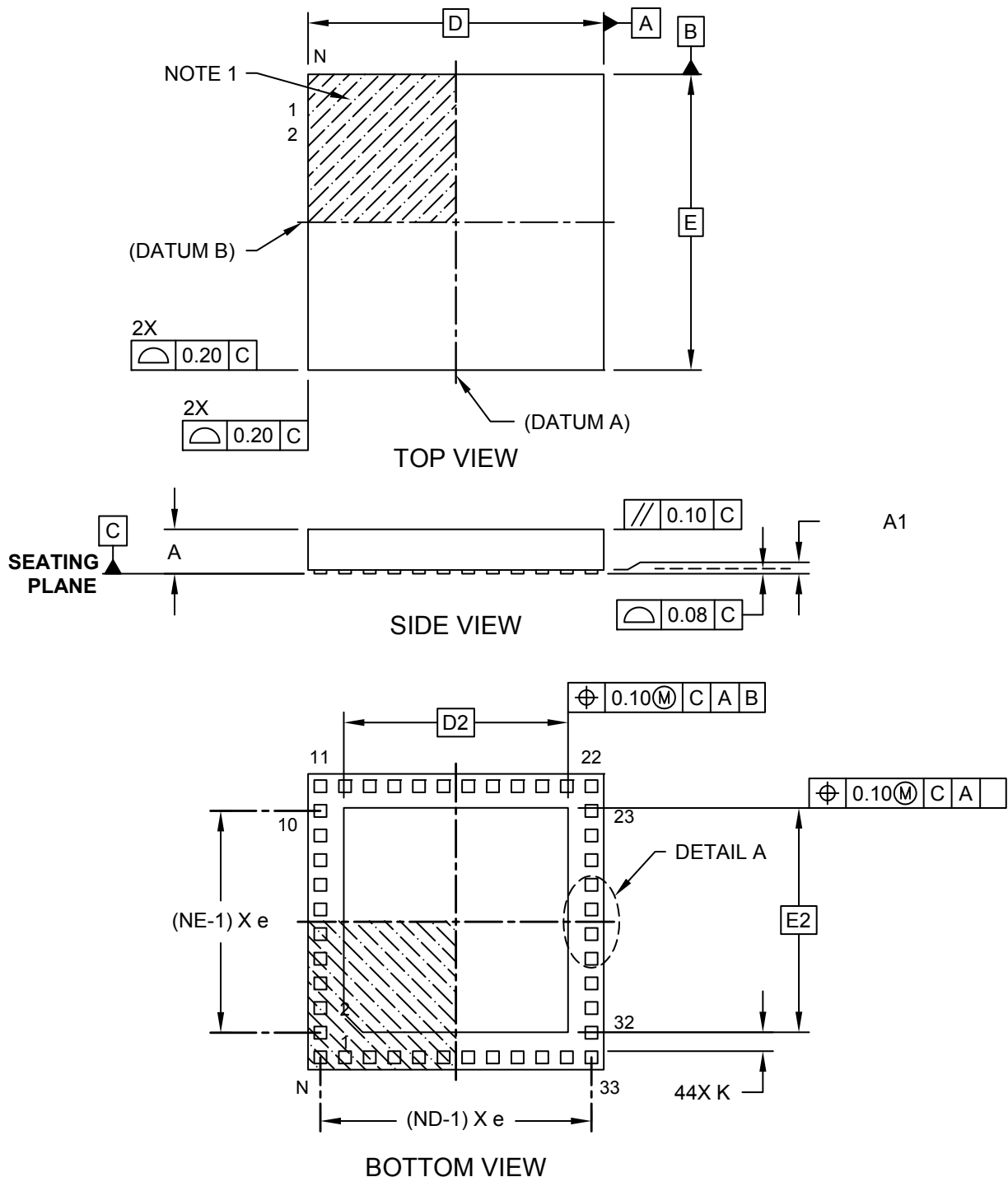

## Package Outlines and Dimensions

### 44-Terminal Very Thin Leadless Array Package (TL) – 6x6x0.9 mm Body With Exposed Pad [VTLA]

**Note:** For the most current package drawings, please see the Microchip Packaging Specification located at <http://www.microchip.com/packaging>

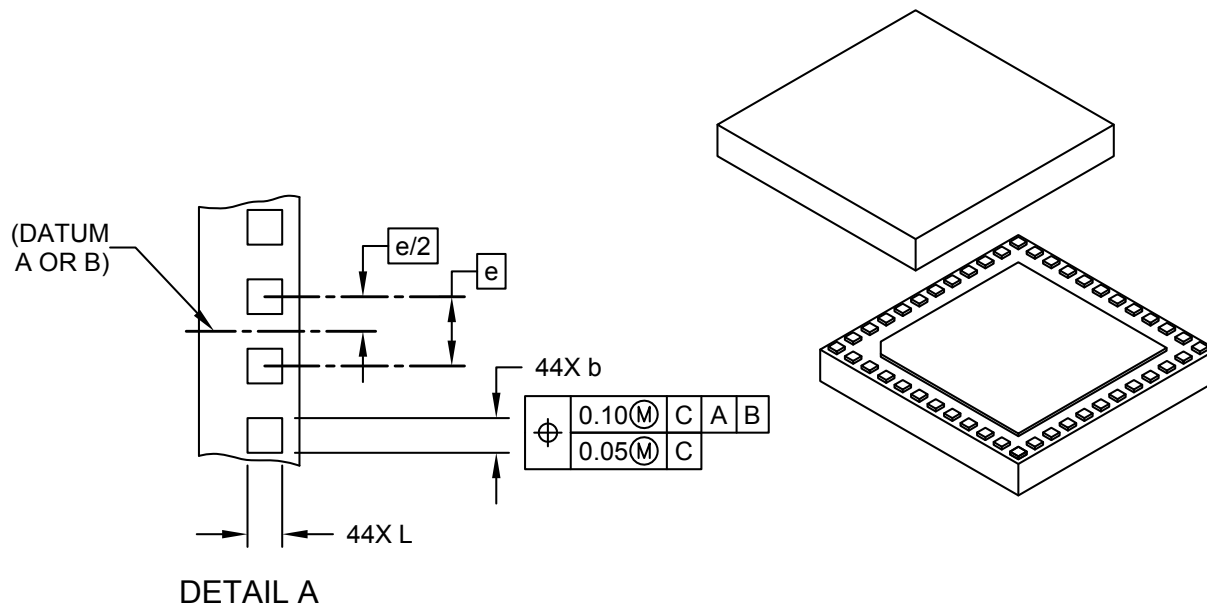

Dimension	Units	MILLIMETERS		
		Limits	MIN	NOM
Number of Terminals	N		44	
Number of Terminals per Side	ND		12	
Number of Terminals per Side	NE		10	
Pitch	e		0.50 BSC	
Overall Height	A	0.80	0.90	1.00
Standoff	A1	0.025	-	0.075
Overall Width	E		6.00 BSC	
Exposed Pad Width	E2	4.40	4.55	4.70
Overall Length	D		6.00 BSC	
Exposed Pad Length	D2	4.40	4.55	4.70
Terminal Width	b	0.20	0.25	0.30
Terminal Length	L	0.20	0.25	0.30
Terminal-to-Exposed Pad	K	0.20	-	-

**Notes:**

- Pin 1 visual index feature may vary, but must be located within the hatched area.
- Package is saw singulated.
- Dimensioning and tolerancing per ASME Y14.5M.

BSC: Basic Dimension. Theoretically exact value shown without tolerances.

REF: Reference Dimension, usually without tolerance, for information purposes only.

---



---

## Footprint Outlines and Dimensions

---



---

### 44-Terminal Very Thin Leadless Array Package (TL) – 6x6x0.9 mm Body With Exposed Pad [VTLA]

**Note:** For the most current package drawings, please see the Microchip Packaging Specification located at <http://www.microchip.com/packaging>

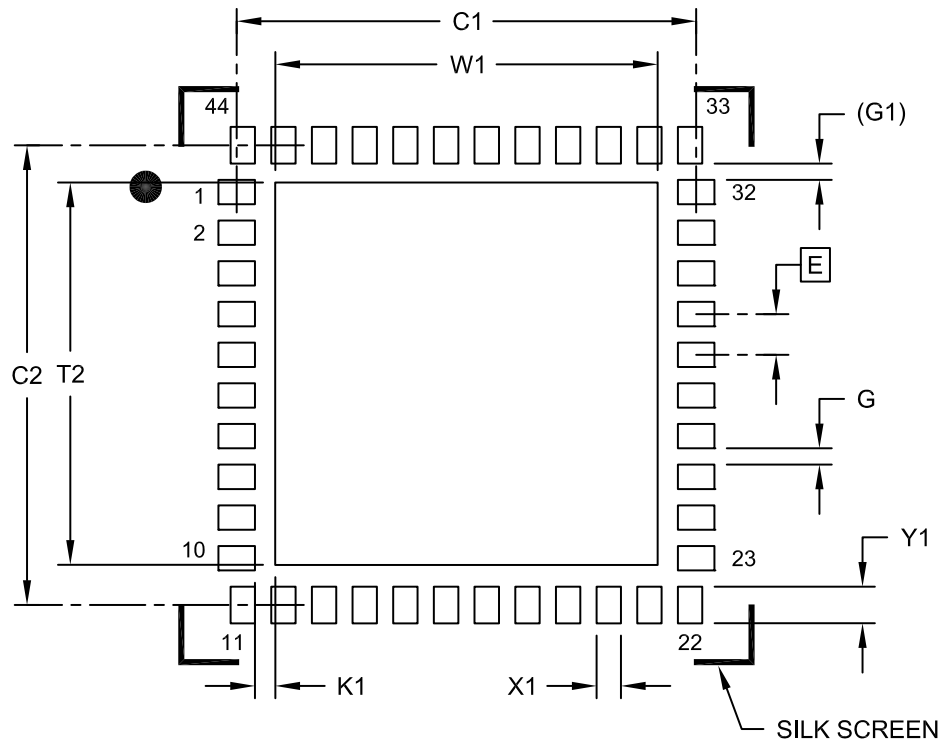

### RECOMMENDED LAND PATTERN

Dimension Limits	Units	MILLIMETERS		
		MIN	NOM	MAX
Terminal Pitch	E	0.50 BSC		
Optional Center Pad Width	W2			4.70
Optional Center Pad Length	T2			4.70
Terminal Pad Spacing	C1		5.65	
Terminal Pad Spacing	C2		5.65	
Terminal Pad Width (X44)	X1			0.30
Terminal Pad Length (X44)	Y1			0.45
Distance Between Pads	(G1)	0.20 REF.		
Distance Between Pads	G	0.20		
Distance Between Pads	K1	0.267		

**Notes:**

1. Dimensioning and tolerancing per ASME Y14.5M

BSC: Basic Dimension. Theoretically exact value shown without tolerances.

Microchip Technology Drawing No. C04-2157A

**Package Outlines and Dimensions**

**124-Terminal Very Thin Leadless Array Package (TL) – 9x9x0.9 mm Body [VTLA]**

**Note:** For the most current package drawings, please see the Microchip Packaging Specification located at <http://www.microchip.com/packaging>

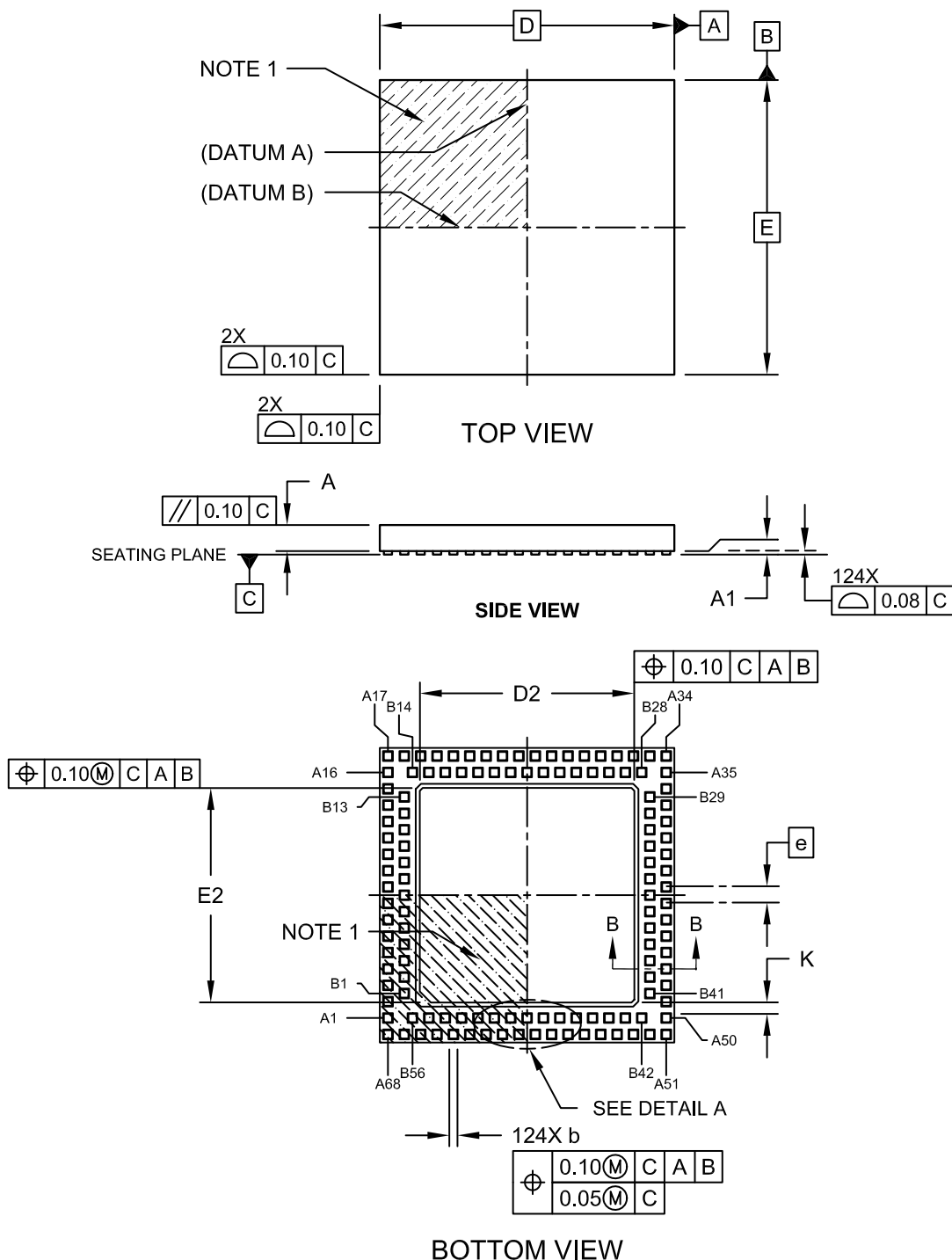

---



---

## Package Outlines and Dimensions

---



---

### 124-Terminal Very Thin Leadless Array Package (TL) – 9x9x0.9 mm Body [VTLA]

**Note:** For the most current package drawings, please see the Microchip Packaging Specification located at <http://www.microchip.com/packaging>

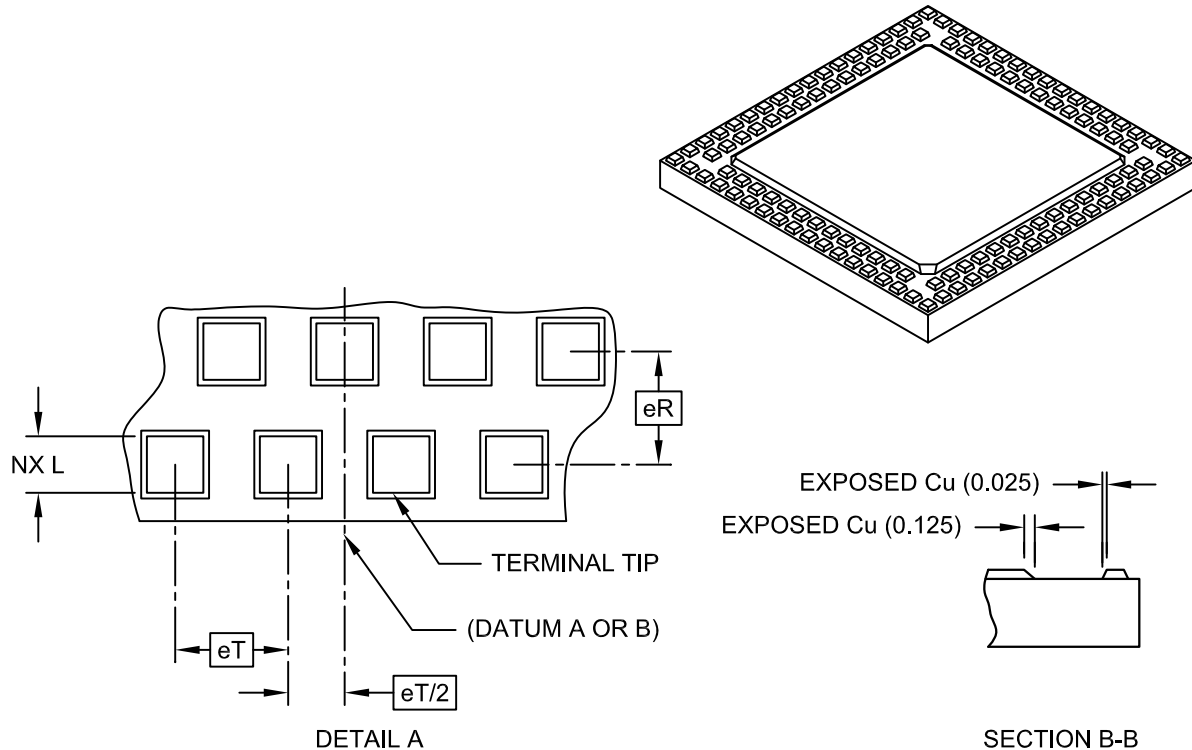

Dimension Limits	Units	MILLIMETERS		
		MIN	NOM	MAX
Number of Pins	N	124		
Pitch	eT	0.50 BSC		
Pitch (Inner to outer terminal ring)	eR	0.50 BSC		
Overall Height	A	0.80	0.85	0.90
Standoff	A1	0.00	-	0.05
Overall Width	E	9.00 BSC		
Exposed Pad Width	E2	6.40	6.55	6.70
Overall Length	D	9.00 BSC		
Exposed Pad Length	D2	6.40	6.55	6.70
Contact Width	b	0.20	0.25	0.30
Contact Length	L	0.20	0.25	0.30
Contact-to-Exposed Pad	K	0.20	-	-

**Notes:**

1. Pin 1 visual index feature may vary, but must be located within the hatched area.
2. Package is saw singulated.
3. Dimensioning and tolerancing per ASME Y14.5M.
  - BSC: Basic Dimension. Theoretically exact value shown without tolerances.
  - REF: Reference Dimension, usually without tolerance, for information purposes only.

**Footprint Outlines and Dimensions**

**124-Very Thin Leadless Array Package (TL) – 9x9x0.9 mm Body [VTLA]**

**Note:** For the most current package drawings, please see the Microchip Packaging Specification located at <http://www.microchip.com/packaging>

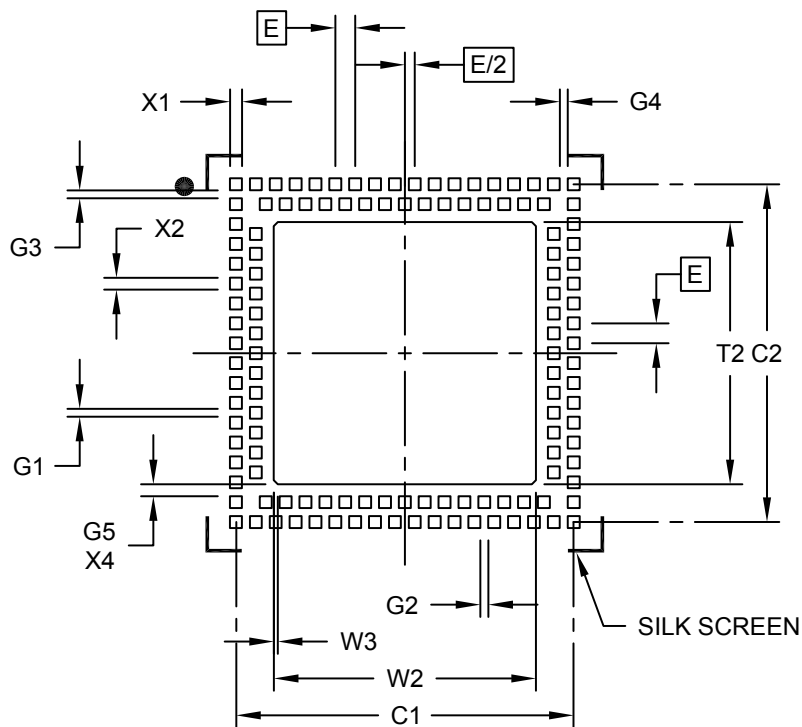

**RECOMMENDED LAND PATTERN**

Dimension Limits	Units	MILLIMETERS		
		MIN	NOM	MAX
Contact Pitch	E	0.50 BSC		
Pad Clearance	G1	0.20		
Pad Clearance	G2	0.20		
Pad Clearance	G3	0.20		
Pad Clearance	G4	0.20		
Contact to Center Pad Clearance (X4)	G5	0.30		
Optional Center Pad Width	T2			6.60
Optional Center Pad Length	W2			6.60
Optional Center Pad Chamfer (X4)	W3		0.10	
Contact Pad Spacing	C1		8.50	
Contact Pad Spacing	C2		8.50	
Contact Pad Width (X124)	X1			0.30
Contact Pad Length (X124)	X2			0.30

**Notes:**

1. Dimensioning and tolerancing per ASME Y14.5M

BSC: Basic Dimension. Theoretically exact value shown without tolerances.

Microchip Technology Drawing No. C04-2193A

---

---

**Package Outlines and Dimensions**

---

---

**MSOP**

**Package Outlines and Dimensions**

**8-Lead Plastic Micro Small Outline Package (MS) [MSOP]**

**Note:** For the most current package drawings, please see the Microchip Packaging Specification located at <http://www.microchip.com/packaging>

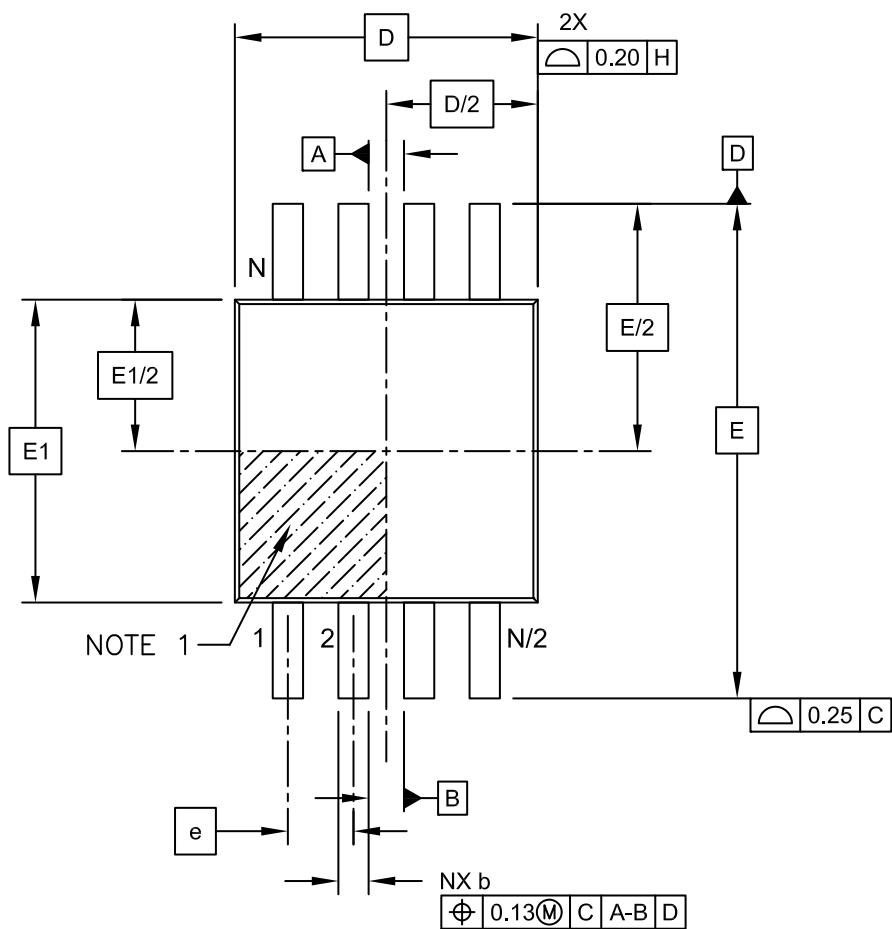

**TOP VIEW**

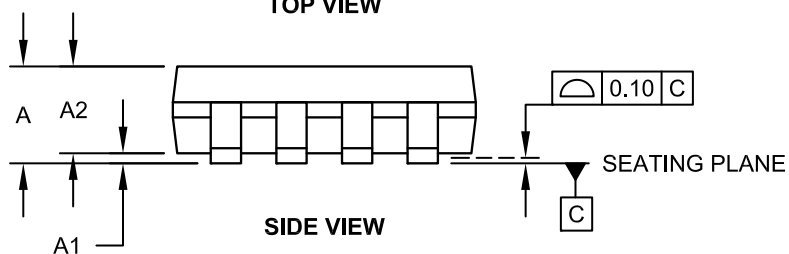

**SIDE VIEW**

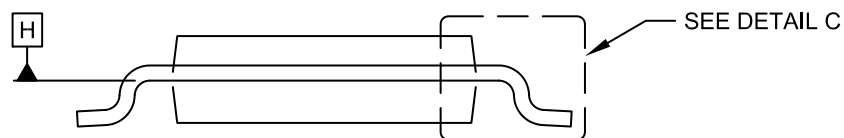

**END VIEW**



---



---

## Package Outlines and Dimensions

---



---

### 8-Lead Plastic Micro Small Outline Package (MS) [MSOP]

**Note:** For the most current package drawings, please see the Microchip Packaging Specification located at <http://www.microchip.com/packaging>

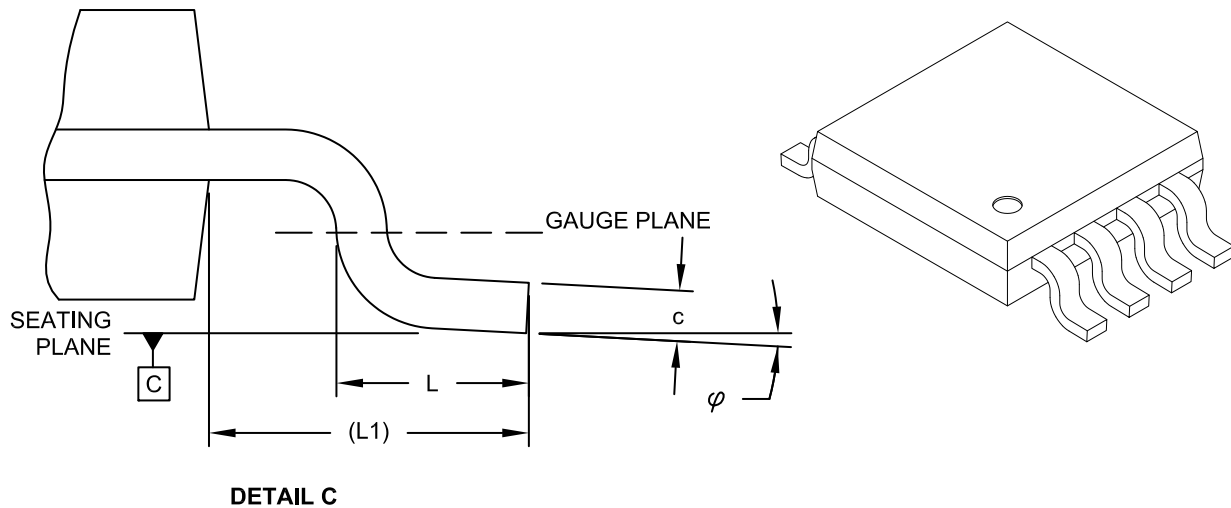

Dimension Limits	Units	MILLIMETERS		
		MIN	NOM	MAX
Number of Pins	N		8	
Pitch	e	0.65 BSC		
Overall Height	A	-	-	1.10
Molded Package Thickness	A2	0.75	0.85	0.95
Standoff	A1	0.00	-	0.15
Overall Width	E	4.90 BSC		
Molded Package Width	E1	3.00 BSC		
Overall Length	D	3.00 BSC		
Foot Length	L	0.40	0.60	0.80
Footprint	L1	0.95 REF		
Foot Angle	$\phi$	0°	-	8°
Lead Thickness	c	0.08	-	0.23
Lead Width	b	0.22	-	0.40

**Notes:**

1. Pin 1 visual index feature may vary, but must be located within the hatched area.
2. Dimensions D and E1 do not include mold flash or protrusions. Mold flash or protrusions shall not exceed 0.15mm per side.
3. Dimensioning and tolerancing per ASME Y14.5M.
  - BSC: Basic Dimension. Theoretically exact value shown without tolerances.
  - REF: Reference Dimension, usually without tolerance, for information purposes only.

**Footprint Outlines and Dimensions**

8-Lead Plastic Micro Small Outline Package (MS) [MSOP]

**Note:** For the most current package drawings, please see the Microchip Packaging Specification located at <http://www.microchip.com/packaging>

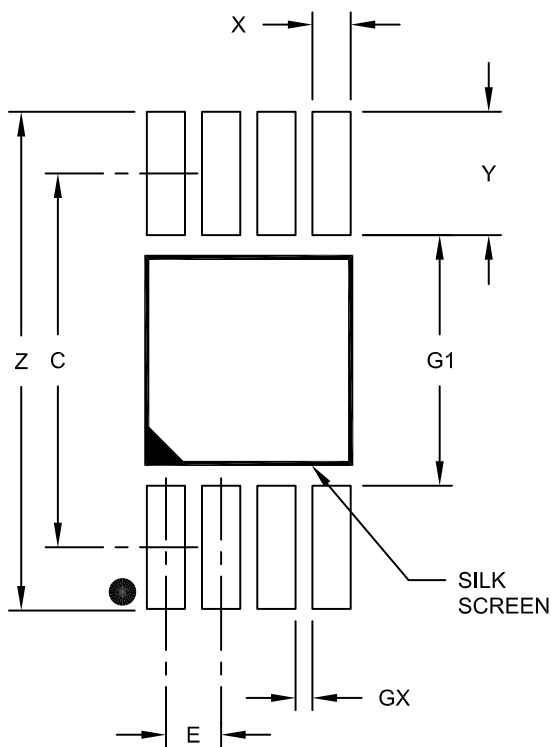

RECOMMENDED LAND PATTERN

Dimension Limits	Units	MILLIMETERS		
		MIN	NOM	MAX
Contact Pitch	E	0.65 BSC		
Contact Pad Spacing	C		4.40	
Overall Width	Z			5.85
Contact Pad Width (X8)	X1			0.45
Contact Pad Length (X8)	Y1			1.45
Distance Between Pads	G1	2.95		
Distance Between Pads	GX	0.20		

Notes:

1. Dimensioning and tolerancing per ASME Y14.5M

BSC: Basic Dimension. Theoretically exact value shown without tolerances.

Microchip Technology Drawing No. C04-2111A

**Package Outlines and Dimensions**

**8-Lead Plastic Micro Small Outline Package (UA) [MSOP]**

**Note:** For the most current package drawings, please see the Microchip Packaging Specification located at <http://www.microchip.com/packaging>

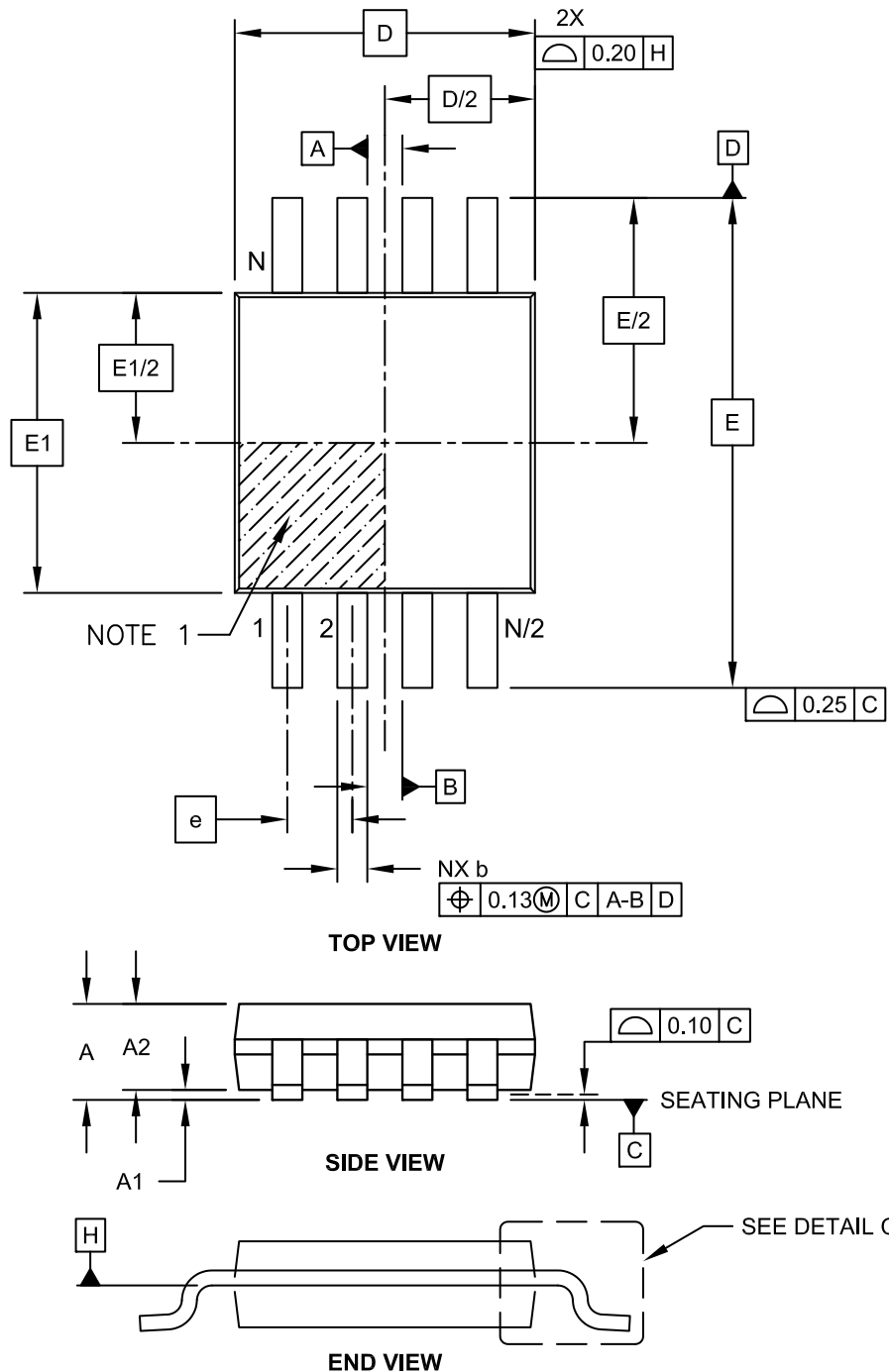

**Package Outlines and Dimensions**

**8-Lead Plastic Micro Small Outline Package (UA) [MSOP]**

**Note:** For the most current package drawings, please see the Microchip Packaging Specification located at <http://www.microchip.com/packaging>

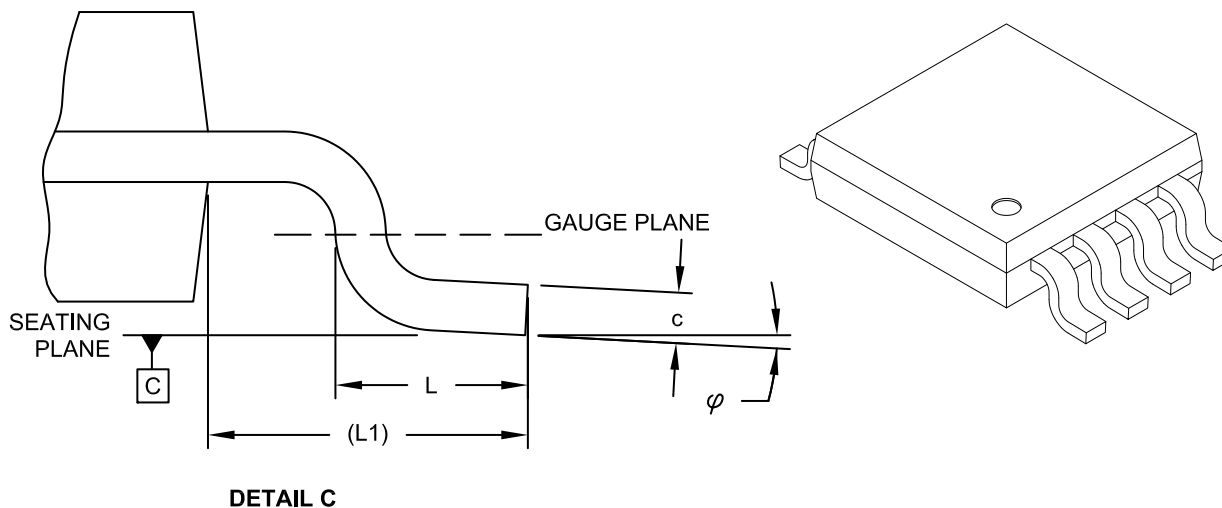

Dimension Limits	Units	MILLIMETERS		
		MIN	NOM	MAX
Number of Pins	N		8	
Pitch	e	0.65 BSC		
Overall Height	A	-	-	1.10
Molded Package Thickness	A2	0.75	0.85	0.95
Standoff	A1	0.00	-	0.15
Overall Width	E	4.90 BSC		
Molded Package Width	E1	3.00 BSC		
Overall Length	D	3.00 BSC		
Foot Length	L	0.40	0.60	0.80
Footprint	L1	0.95 REF		
Foot Angle	$\phi$	0°	-	8°
Lead Thickness	c	0.08	-	0.23
Lead Width	b	0.22	-	0.40

**Notes:**

- Pin 1 visual index feature may vary, but must be located within the hatched area.
- Dimensions D and E1 do not include mold flash or protrusions. Mold flash or protrusions shall not exceed 0.15mm per side.
- Dimensioning and tolerancing per ASME Y14.5M.  
 BSC: Basic Dimension. Theoretically exact value shown without tolerances.  
 REF: Reference Dimension, usually without tolerance, for information purposes only.

---



---

## Footprint Outlines and Dimensions

---



---

### 8-Lead Plastic Micro Small Outline Package (UA) [MSOP]

**Note:** For the most current package drawings, please see the Microchip Packaging Specification located at <http://www.microchip.com/packaging>

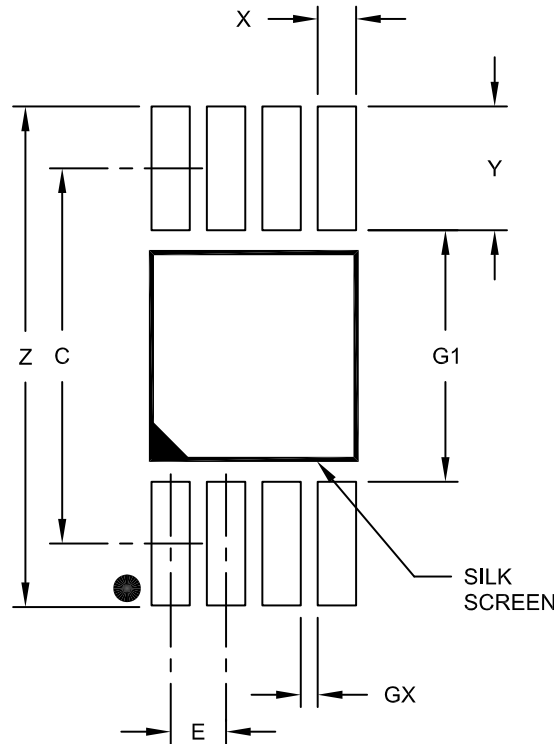

RECOMMENDED LAND PATTERN

Dimension Limits	Units	MILLIMETERS		
		MIN	NOM	MAX
Contact Pitch	E	0.65 BSC		
Contact Pad Spacing	C		4.40	
Overall Width	Z			5.85
Contact Pad Width (X8)	X1			0.45
Contact Pad Length (X8)	Y1			1.45
Distance Between Pads	G1	2.95		
Distance Between Pads	GX	0.20		

**Notes:**

1. Dimensioning and tolerancing per ASME Y14.5M

BSC: Basic Dimension. Theoretically exact value shown without tolerances.

Microchip Technology Drawing No. C04-2111A

**Package Outlines and Dimensions**

**10-Lead Plastic Micro Small Outline Package (MS) [MSOP]**

**Note:** For the most current package drawings, please see the Microchip Packaging Specification located at <http://www.microchip.com/packaging>

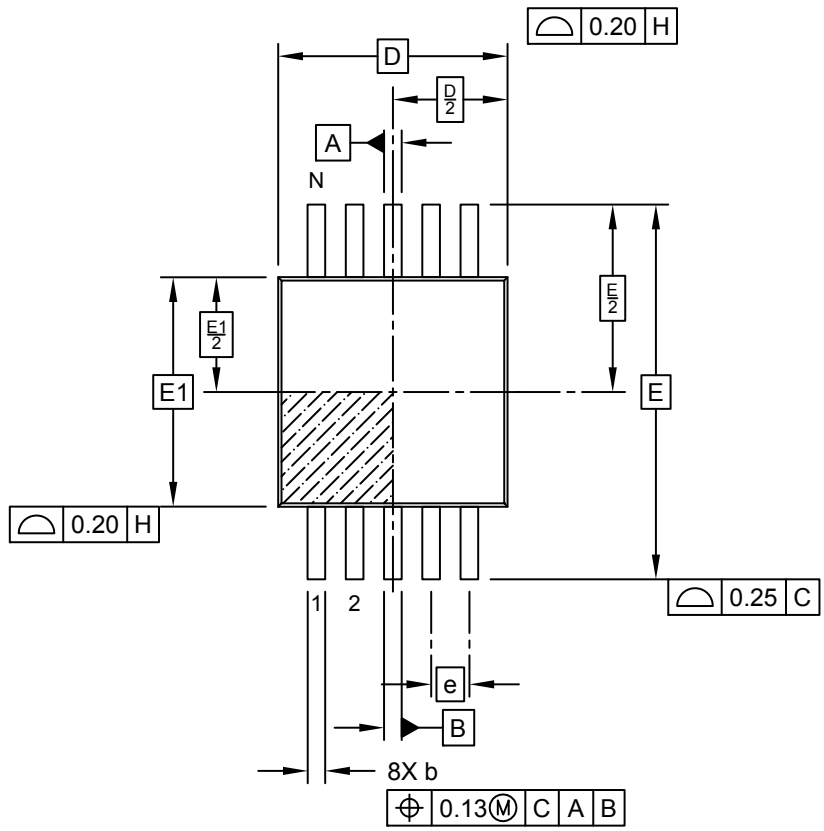

TOP VIEW

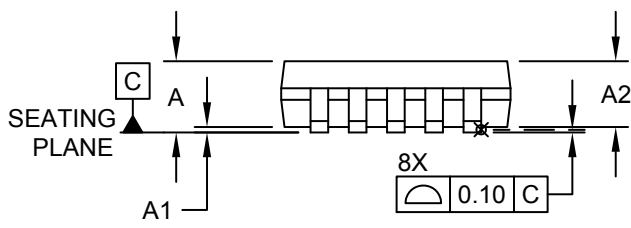

SIDE VIEW

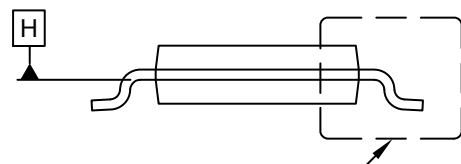

SEE DETAIL A  
END VIEW

---



---

## Package Outlines and Dimensions

---



---

### 10-Lead Plastic Micro Small Outline Package (MS) [MSOP]

**Note:** For the most current package drawings, please see the Microchip Packaging Specification located at <http://www.microchip.com/packaging>

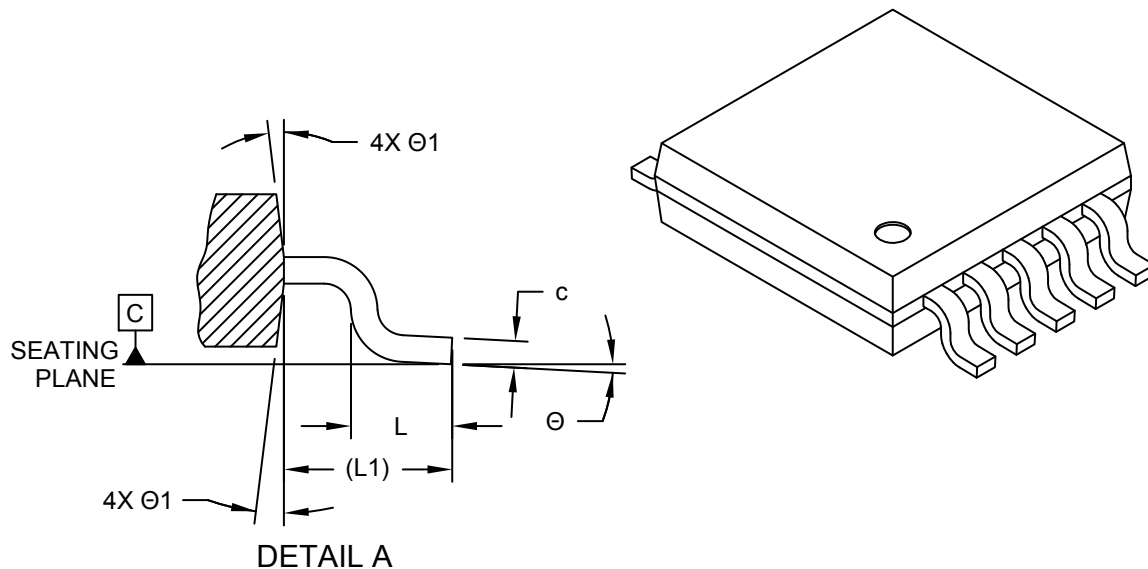

Dimension Limits	Units	MILLIMETERS		
		MIN	NOM	MAX
Number of Pins	N	10		
Pitch	e	0.50 BSC		
Overall Height	A	-	-	1.10
Molded Package Thickness	A2	0.75	0.85	0.95
Standoff	A1	0.00	-	0.15
Overall Width	E	4.90 BSC		
Molded Package Width	E1	3.00 BSC		
Overall Length	D	3.00 BSC		
Foot Length	L	0.40	0.60	0.80
Footprint	L1	0.95 REF		
Mold Draft Angle	Ø	0°	-	8°
Foot Angle	Ø1	5°	-	15°
Lead Thickness	c	0.08	-	0.23
Lead Width	b	0.15	-	0.33

**Notes:**

1. Pin 1 visual index feature may vary, but must be located within the hatched area.
2. Dimensions D and E1 do not include mold flash or protrusions. Mold flash or protrusions shall not exceed 0.15mm per side.
3. Dimensioning and tolerancing per ASME Y14.5M.
  - BSC: Basic Dimension. Theoretically exact value shown without tolerances.
  - REF: Reference Dimension, usually without tolerance, for information purposes only.

**Footprint Outlines and Dimensions**

**10-Lead Plastic Micro Small Outline Package (MS) [MSOP]**

**Note:** For the most current package drawings, please see the Microchip Packaging Specification located at <http://www.microchip.com/packaging>

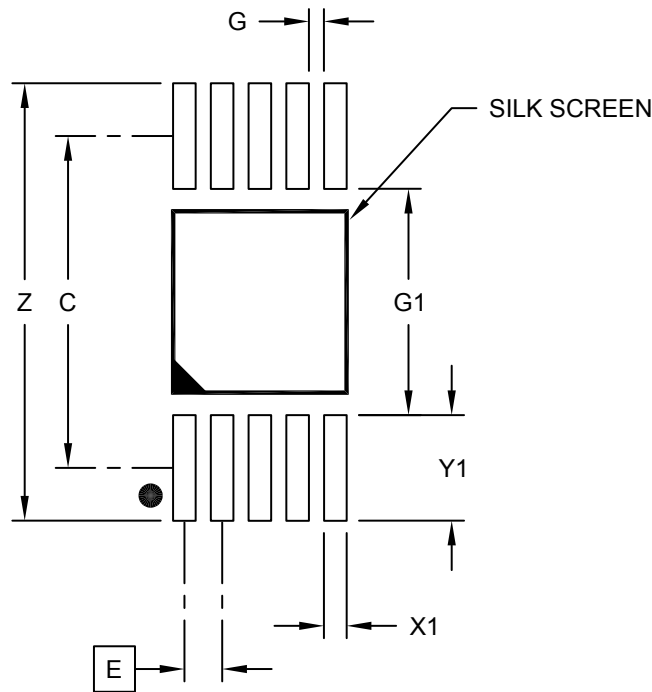

**RECOMMENDED LAND PATTERN**

Dimension Limits	Units	MILLIMETERS		
		MIN	NOM	MAX
Contact Pitch	E	0.50 BSC		
Contact Pad Spacing	C		4.40	
Overall Width	Z			5.80
Contact Pad Width (X10)	X1			0.30
Contact Pad Length (X10)	Y1			1.40
Distance Between Pads (X5)	G1	3.00		
Distance Between Pads (X8)	G	0.20		

**Notes:**

1. Dimensioning and tolerancing per ASME Y14.5M

BSC: Basic Dimension. Theoretically exact value shown without tolerances.



**Package Outlines and Dimensions**

**10-Lead Plastic Micro Small Outline Package (UN) [MSOP]**

**Note:** For the most current package drawings, please see the Microchip Packaging Specification located at <http://www.microchip.com/packaging>

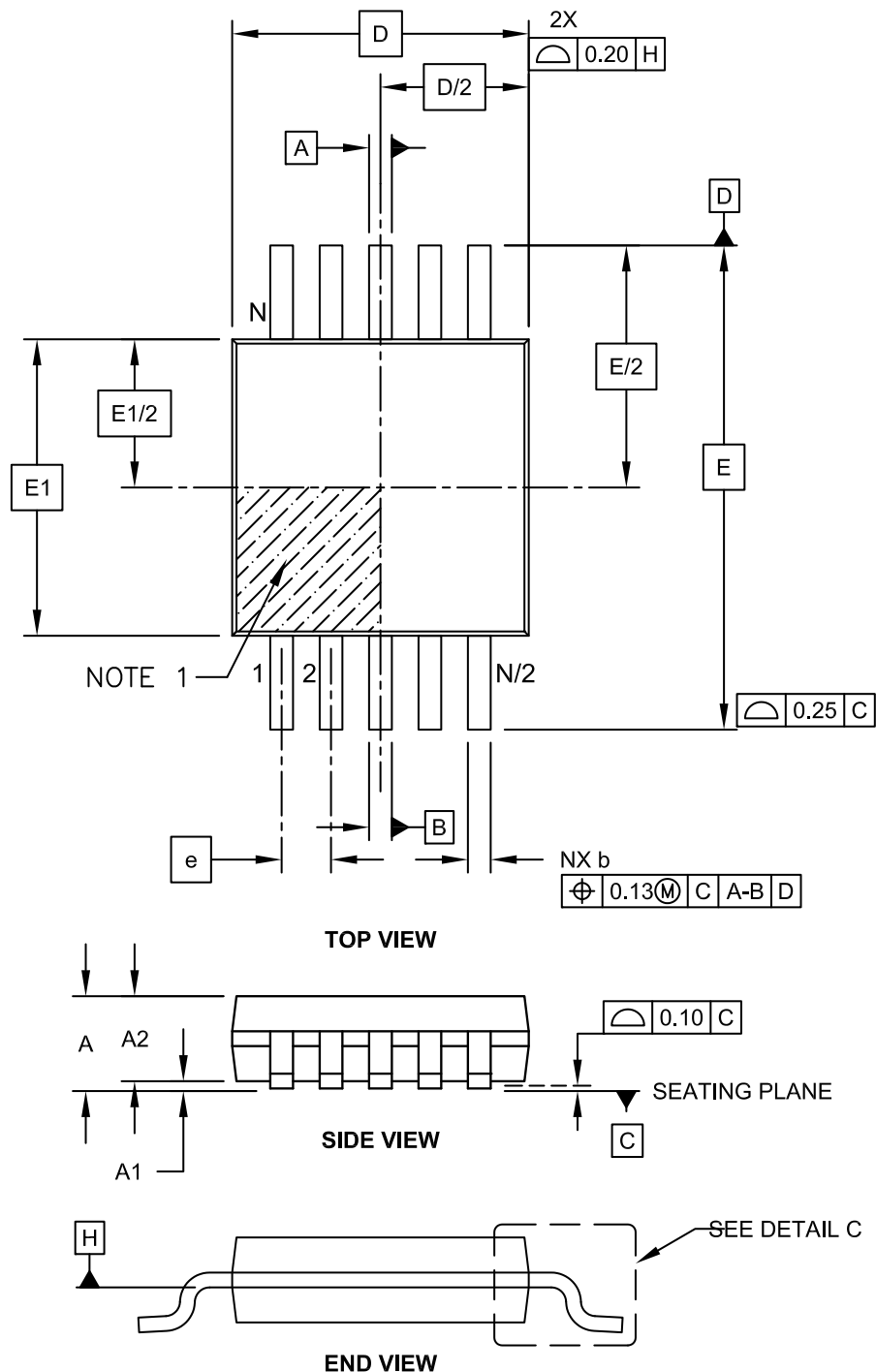

**Package Outlines and Dimensions**

**10-Lead Plastic Micro Small Outline Package (UN) [MSOP]**

**Note:** For the most current package drawings, please see the Microchip Packaging Specification located at <http://www.microchip.com/packaging>

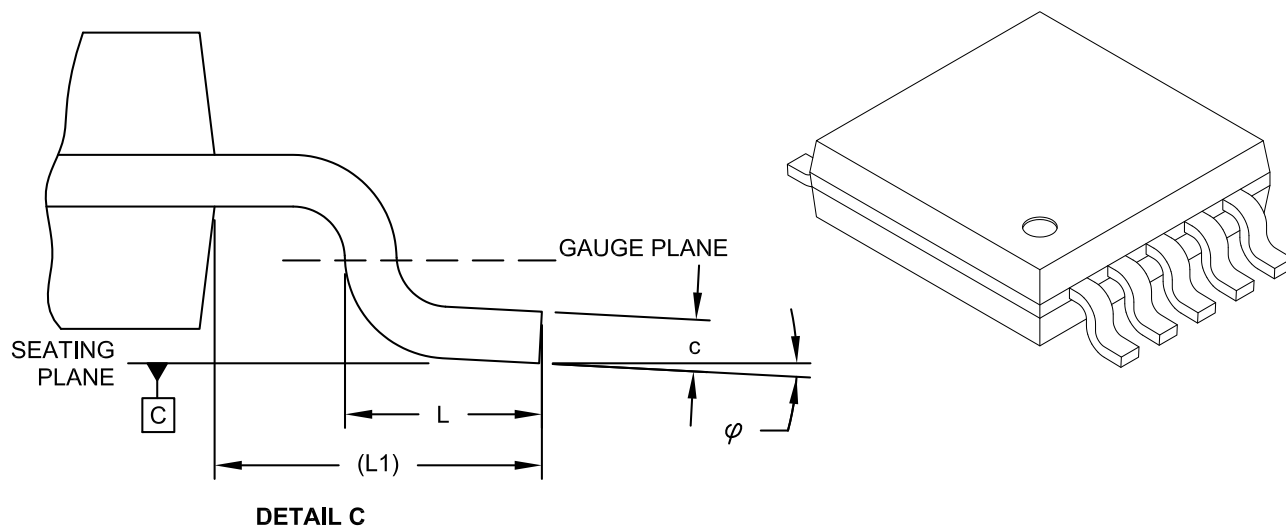

Dimension Limits	Units	MILLIMETERS		
		MIN	NOM	MAX
Number of Pins	N	10		
Pitch	e	0.50 BSC		
Overall Height	A	-	-	1.10
Molded Package Thickness	A2	0.75	0.85	0.95
Standoff	A1	0.00	-	0.15
Overall Width	E	4.90 BSC		
Molded Package Width	E1	3.00 BSC		
Overall Length	D	3.00 BSC		
Foot Length	L	0.40	0.60	0.80
Footprint	L1	0.95 REF		
Foot Angle	φ	0°	-	8°
Lead Thickness	c	0.08	-	0.23
Lead Width	b	0.15	-	0.33

**Notes:**

- Pin 1 visual index feature may vary, but must be located within the hatched area.
- Dimensions D and E1 do not include mold flash or protrusions. Mold flash or protrusions shall not exceed 0.15mm per side.
- Dimensioning and tolerancing per ASME Y14.5M.  
 BSC: Basic Dimension. Theoretically exact value shown without tolerances.  
 REF: Reference Dimension, usually without tolerance, for information purposes only.

---



---

## Footprint Outlines and Dimensions

---



---

### 10-Lead Plastic Micro Small Outline Package (UN) [MSOP]

**Note:** For the most current package drawings, please see the Microchip Packaging Specification located at <http://www.microchip.com/packaging>

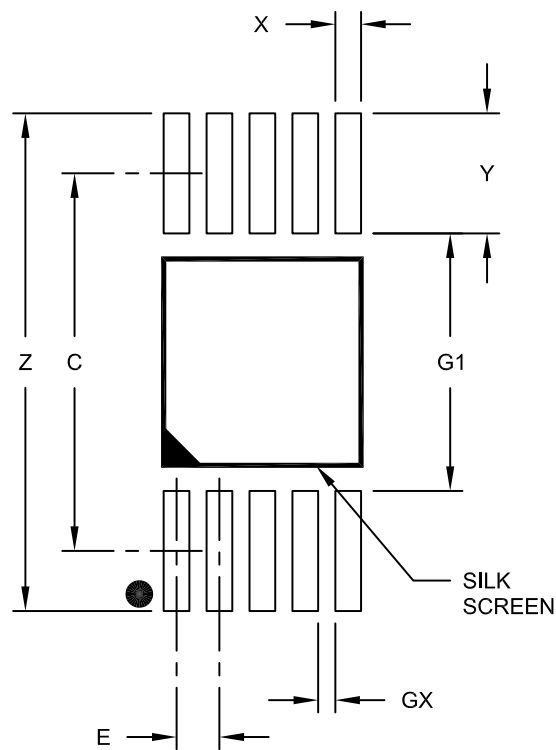

**RECOMMENDED LAND PATTERN**

Dimension Limits	Units	MILLIMETERS		
		MIN	NOM	MAX
Contact Pitch	E	0.50 BSC		
Contact Pad Spacing	C		4.40	
Overall Width	Z			5.80
Contact Pad Width (X10)	X1			0.30
Contact Pad Length (X10)	Y1			1.40
Distance Between Pads	G1	3.00		
Distance Between Pads	GX	0.20		

**Notes:**

1. Dimensioning and tolerancing per ASME Y14.5M

BSC: Basic Dimension. Theoretically exact value shown without tolerances.

Microchip Technology Drawing No. C04-2021A



**MICROCHIP**

---

---

**Package Outlines and Dimensions**

---

---

NOTES:

---

---

**Package Outlines and Dimensions**

---

---

**QSOP**

**Package Outlines and Dimensions**

**16-Lead Plastic Shrink Small Outline Narrow Body (QR) - .150" Body [QSOP]  
SMSC Legacy "SSOP" Package A2C**

**Note:** For the most current package drawings, please see the Microchip Packaging Specification located at <http://www.microchip.com/packaging>

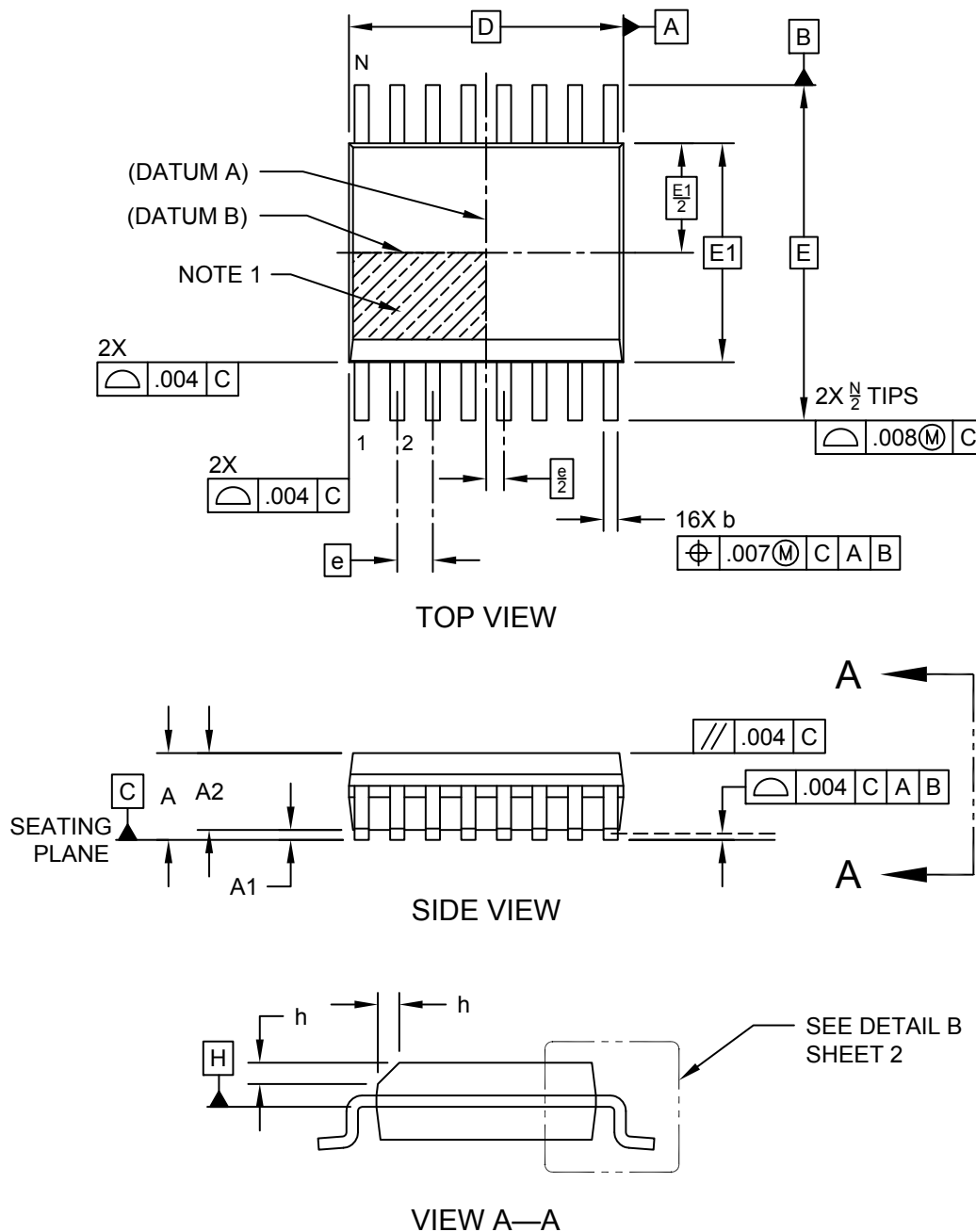

---



---

## Package Outlines and Dimensions

---



---

### 16-Lead Plastic Shrink Small Outline Narrow Body (QR) - .150" Body [QSOP] SMSC Legacy "SSOP" Package A2C

**Note:** For the most current package drawings, please see the Microchip Packaging Specification located at <http://www.microchip.com/packaging>

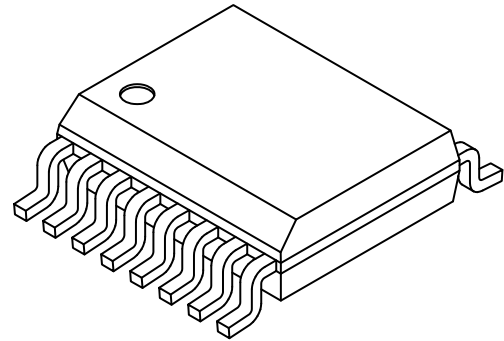
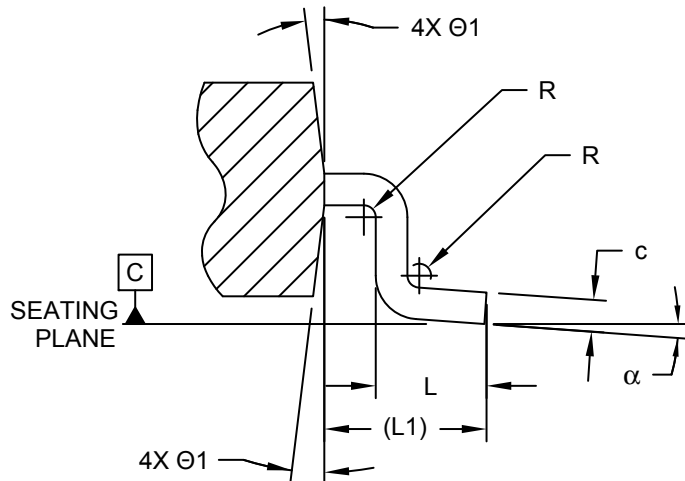

DETAIL B

Dimension Limits	Units	INCHES		
		MIN	NOM	MAX
Number of Pins	N	16		
Pitch	e	.025 BSC		
Overall Height	A	.053	-	.069
Standoff §	A1	.004	-	.010
Molded Package Height	A2	.049	-	.065
Overall Width	E	.236 BSC		
Molded Package Width	E1	.154 BSC		
Overall Length	D	.193 BSC		
Chamfer Distance	h	.010	-	.020
Lead Thickness	c	.006	-	.010
Lead Width	b	.008	.010	.012
Lead Bend Radius	R	.003	-	-
Footprint	(L1)	.041 REF		
Foot Length	L	.016	-	0.35
Foot Angle	α	0°	-	8°
Mold Draft Angle	Ø1	5°	-	15°

**Notes:**

1. Chamfer feature is optional. If it is not present, then a Pin 1 visual index feature must be located within the hatched area.
2. § Significant Characteristic
3. Dimensions D and E1 do not include mold flash or protrusions. Mold flash or protrusions shall not exceed .006" per side.
4. Dimensioning and tolerancing per ASME Y14.5M
  - BSC: Basic Dimension. Theoretically exact value shown without tolerances.
  - REF: Reference Dimension, usually without tolerance, for information purposes only.

**Footprint Outlines and Dimensions**

**16-Lead Plastic Shrink Small Outline Narrow Body (QR) - .150" Body [QSOP]  
SMSC Legacy "SSOP" Package A2C**

**Note:** For the most current package drawings, please see the Microchip Packaging Specification located at <http://www.microchip.com/packaging>

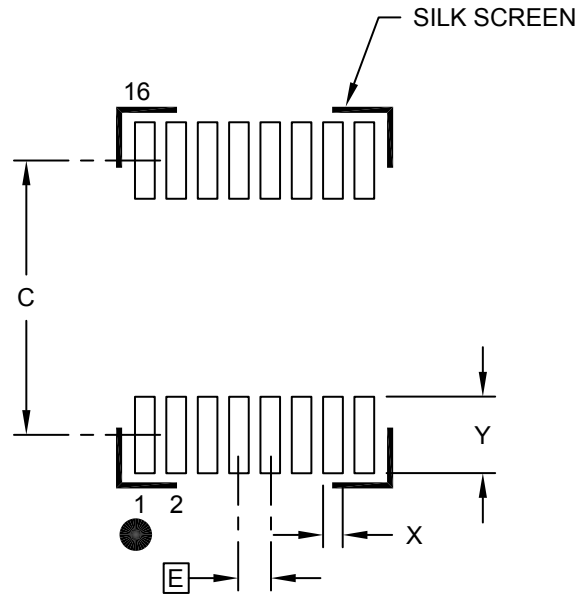

**RECOMMENDED LAND PATTERN**

Units		INCHES		
Dimension Limits		MIN	NOM	MAX
Contact Pitch	E	.025 BSC		
Contact Pad Spacing	C		.213	
Contact Pad Width (X16)	X			.016
Contact Pad Length (X16)	Y			.061

**Notes:**

1. Dimensioning and tolerancing per ASME Y14.5M

BSC: Basic Dimension. Theoretically exact value shown without tolerances.



**Package Outlines and Dimensions**

**24-Lead Plastic Shrink Small Outline Narrow Body (QR) - .150" Body [QSOP]  
SMSC Legacy "SSOP" Package C2C**

**Note:** For the most current package drawings, please see the Microchip Packaging Specification located at <http://www.microchip.com/packaging>

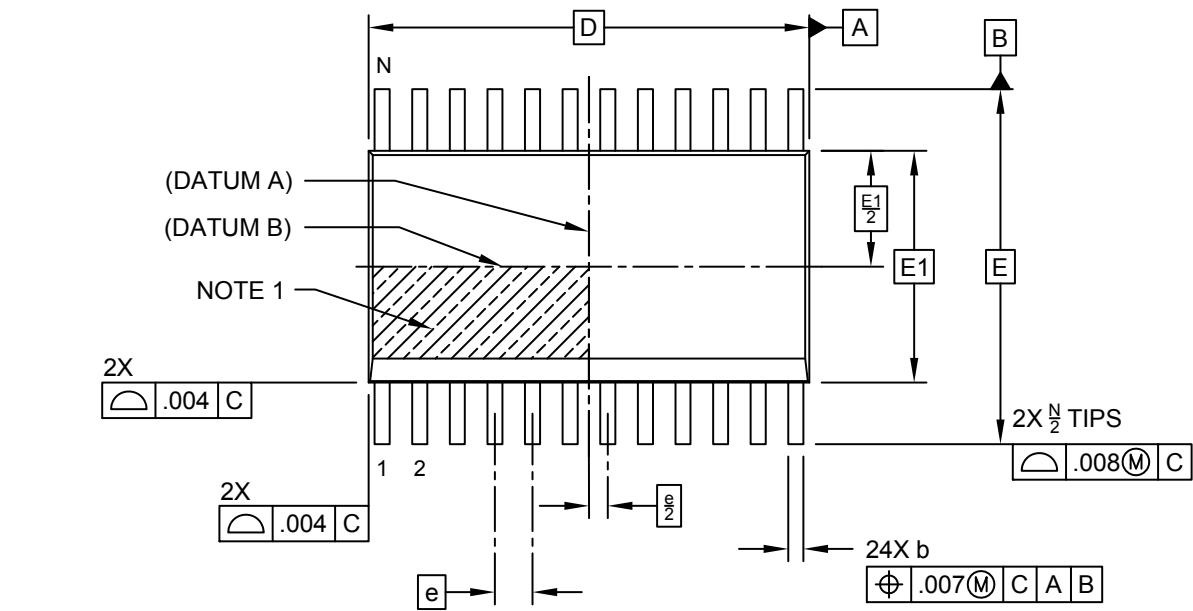

TOP VIEW

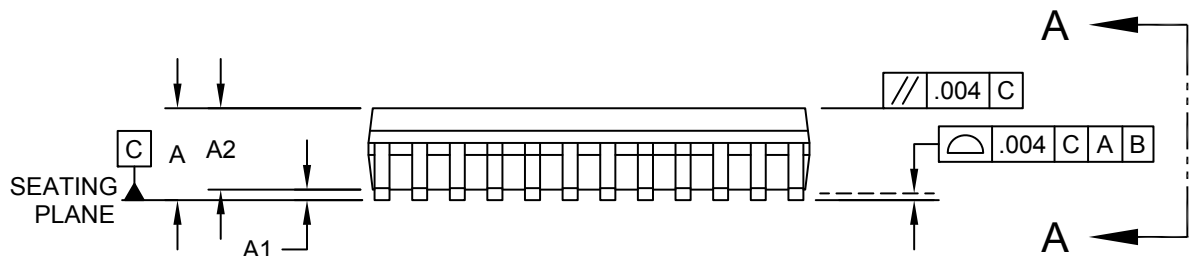

SIDE VIEW

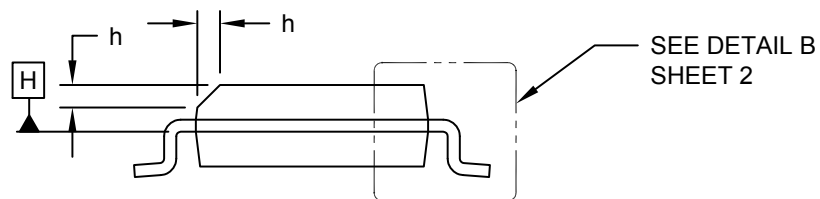

VIEW A—A

**Package Outlines and Dimensions**

**24-Lead Plastic Shrink Small Outline Narrow Body (QR) - .150" Body [QSOP]  
SMSC Legacy "SSOP" Package C2C**

**Note:** For the most current package drawings, please see the Microchip Packaging Specification located at <http://www.microchip.com/packaging>

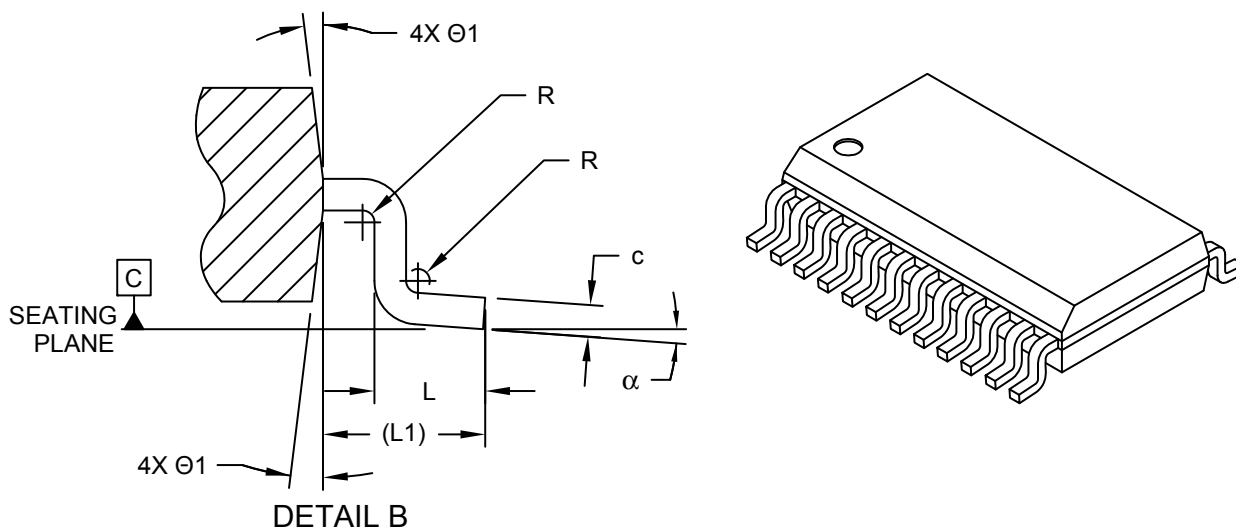

Dimension Limits	Units	INCHES		
		MIN	NOM	MAX
Number of Pins	N	24		
Pitch	e	.025 BSC		
Overall Height	A	.053	-	.069
Standoff §	A1	.004	-	.010
Molded Package Height	A2	.049	-	.065
Overall Width	E	.236 BSC		
Molded Package Width	E1	.154 BSC		
Overall Length	D	.341 BSC		
Chamfer Distance	h	.010	-	.020
Lead Thickness	c	.006	-	.010
Lead Width	b	.008	.010	.012
Lead Bend Radius	R	.003	-	-
Footprint	(L1)	.041 REF		
Foot Length	L	.016	-	.050
Foot Angle	α	0°	-	8°
Mold Draft Angle	Ø1	5°	-	15°

**Notes:**

1. Chamfer feature is optional. If it is not present, then a Pin 1 visual index feature must be located within the hatched area.
2. § Significant Characteristic
3. Dimensions D and E1 do not include mold flash or protrusions. Mold flash or protrusions shall not exceed .006" per side.
4. Dimensioning and tolerancing per ASME Y14.5M
  - BSC: Basic Dimension. Theoretically exact value shown without tolerances.
  - REF: Reference Dimension, usually without tolerance, for information purposes only.

## Footprint Outlines and Dimensions

### 24-Lead Plastic Shrink Small Outline Narrow Body (QR) - .150" Body [QSOP] SMSC Legacy "SSOP" Package C2C

**Note:** For the most current package drawings, please see the Microchip Packaging Specification located at <http://www.microchip.com/packaging>

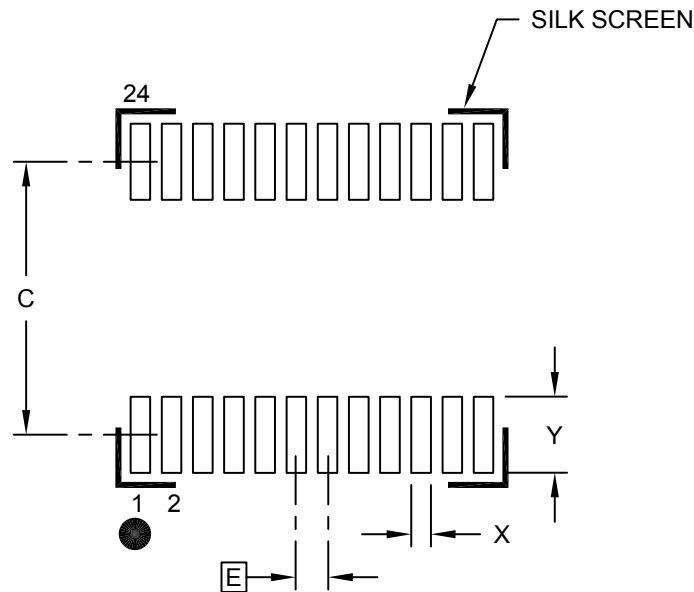

RECOMMENDED LAND PATTERN

	Units	INCHES		
		MIN	NOM	MAX
Dimension Limits				
Contact Pitch	E	.025 BSC		
Contact Pad Spacing	C		.213	
Contact Pad Width (X24)	X			.016
Contact Pad Length (X24)	Y			.061

**Notes:**

1. Dimensioning and tolerancing per ASME Y14.5M  
BSC: Basic Dimension. Theoretically exact value shown without tolerances.



**MICROCHIP**

---

---

**Package Outlines and Dimensions**

---

---

NOTES:

---

---

**Package Outlines and Dimensions**

---

---

**SSOP**

## Package Outlines and Dimensions

### 20-Lead Plastic Shrink Small Outline (SS) – 5.30 mm Body [SSOP]

**Note:** For the most current package drawings, please see the Microchip Packaging Specification located at <http://www.microchip.com/packaging>

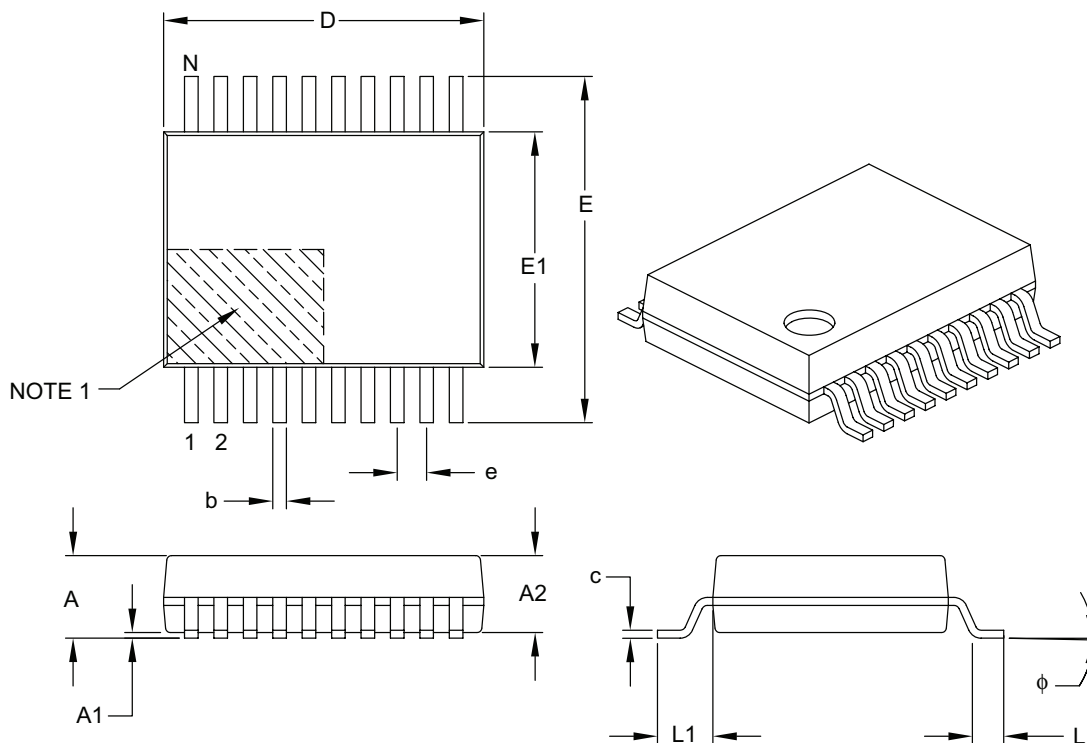

Dimension Limits	Units	MILLIMETERS		
		MIN	NOM	MAX
Number of Pins	N	20		
Pitch	e	0.65 BSC		
Overall Height	A	–	–	2.00
Molded Package Thickness	A2	1.65	1.75	1.85
Standoff	A1	0.05	–	–
Overall Width	E	7.40	7.80	8.20
Molded Package Width	E1	5.00	5.30	5.60
Overall Length	D	6.90	7.20	7.50
Foot Length	L	0.55	0.75	0.95
Footprint	L1	1.25 REF		
Lead Thickness	c	0.09	–	0.25
Foot Angle	$\phi$	0°	4°	8°
Lead Width	b	0.22	–	0.38

**Notes:**

- Pin 1 visual index feature may vary, but must be located within the hatched area.
- Dimensions D and E1 do not include mold flash or protrusions. Mold flash or protrusions shall not exceed 0.20 mm per side.
- Dimensioning and tolerancing per ASME Y14.5M.

BSC: Basic Dimension. Theoretically exact value shown without tolerances.

REF: Reference Dimension, usually without tolerance, for information purposes only.

Microchip Technology Drawing C04-072B

---



---

## Footprint Outlines and Dimensions

---



---

### 20-Lead Plastic Shrink Small Outline (SS) - 5.30 mm Body [SSOP]

**Note:** For the most current package drawings, please see the Microchip Packaging Specification located at <http://www.microchip.com/packaging>

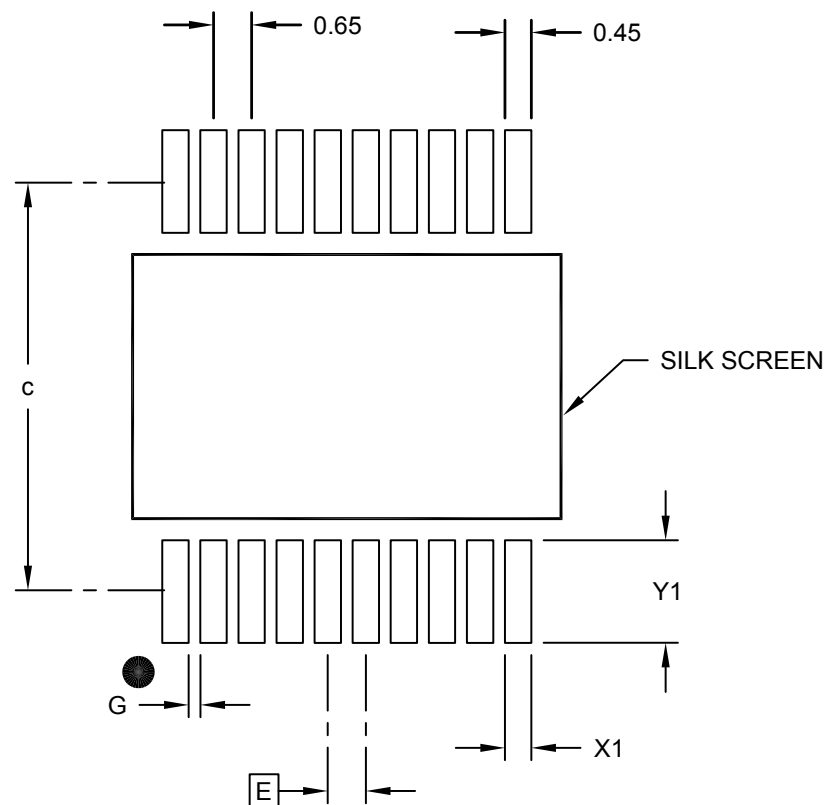

### RECOMMENDED LAND PATTERN

		MILLIMETERS		
		MIN	NOM	MAX
Contact Pitch	E	0.65 BSC		
Contact Pad Spacing	C		7.20	
Contact Pad Width (X20)	X1			0.45
Contact Pad Length (X20)	Y1			1.75
Distance Between Pads	G	0.20		

**Notes:**

1. Dimensioning and tolerancing per ASME Y14.5M  
 BSC: Basic Dimension. Theoretically exact value shown without tolerances.

**Package Outlines and Dimensions**

**24-Lead Plastic Shrink Small Outline (SS) – 5.30 mm Body [SSOP]**

**Note:** For the most current package drawings, please see the Microchip Packaging Specification located at <http://www.microchip.com/packaging>

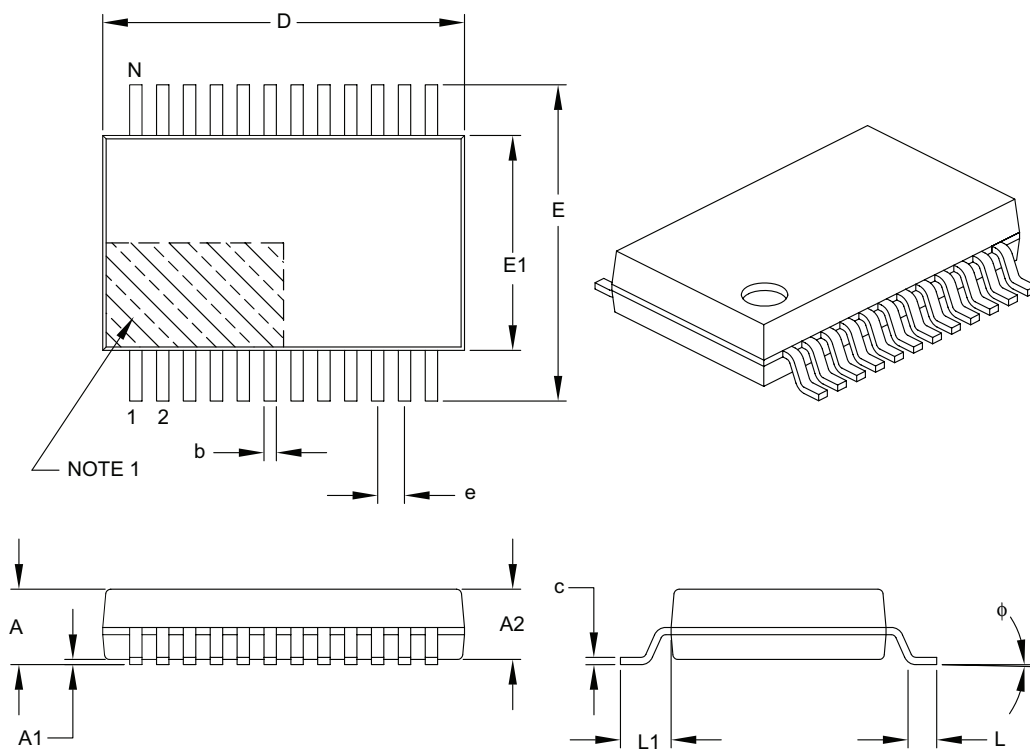

Dimension Limits	Units	MILLIMETERS		
		MIN	NOM	MAX
Number of Pins	N	24		
Pitch	e	0.65 BSC		
Overall Height	A	–	–	2.00
Molded Package Thickness	A2	1.65	1.75	1.85
Standoff	A1	0.05	–	–
Overall Width	E	7.40	7.80	8.20
Molded Package Width	E1	5.00	5.30	5.60
Overall Length	D	7.90	8.20	8.50
Foot Length	L	0.55	0.75	0.95
Footprint	L1	1.25 REF		
Lead Thickness	c	0.09	–	0.25
Foot Angle	φ	0°	4°	8°
Lead Width	b	0.22	–	0.38

**Notes:**

- Pin 1 visual index feature may vary, but must be located within the hatched area.
- Dimensions D and E1 do not include mold flash or protrusions. Mold flash or protrusions shall not exceed 0.20 mm per side.
- Dimensioning and tolerancing per ASME Y14.5M.

BSC: Basic Dimension. Theoretically exact value shown without tolerances.

REF: Reference Dimension, usually without tolerance, for information purposes only.

Microchip Technology Drawing C04-132B



---



---

## Package Outlines and Dimensions

---



---

### 24 Lead Plastic Shrink Small Outline (SS) - 5.30 mm Body [SSOP]

**Note:** For the most current package drawings, please see the Microchip Packaging Specification located at <http://www.microchip.com/packaging>

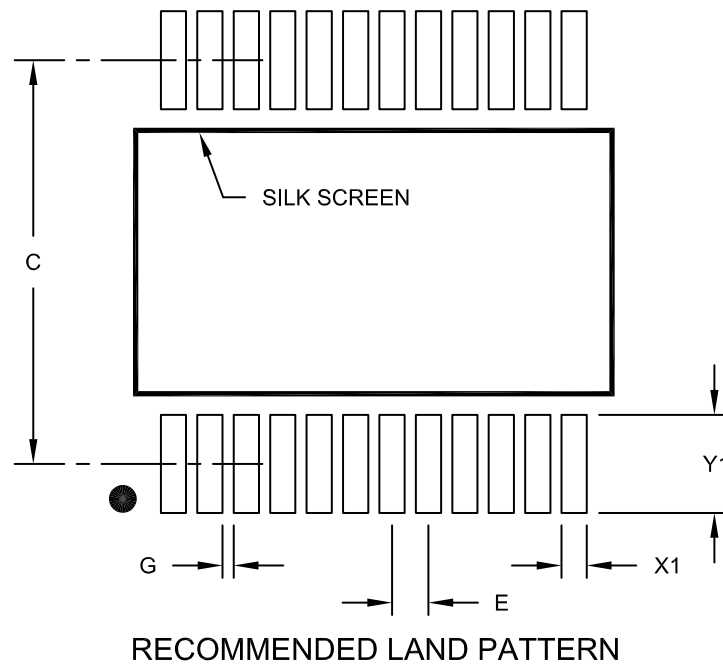

Dimension Limits	Units	MILLIMETERS		
		MIN	NOM	MAX
Contact Pitch	E	0.65 BSC		
Contact Pad Spacing	C		7.20	
Contact Pad Width (X24)	X1			0.45
Contact Pad Length (X24)	Y1			1.75
Distance Between Pads	G	0.20		

**Notes:**

1. Dimensioning and tolerancing per ASME Y14.5M

BSC: Basic Dimension. Theoretically exact value shown without tolerances.

Microchip Technology Drawing No. C04-2132A

**Package Outlines and Dimensions**

**28-Lead Plastic Shrink Small Outline (SS) – 5.30 mm Body [SSOP]**

**Note:** For the most current package drawings, please see the Microchip Packaging Specification located at <http://www.microchip.com/packaging>

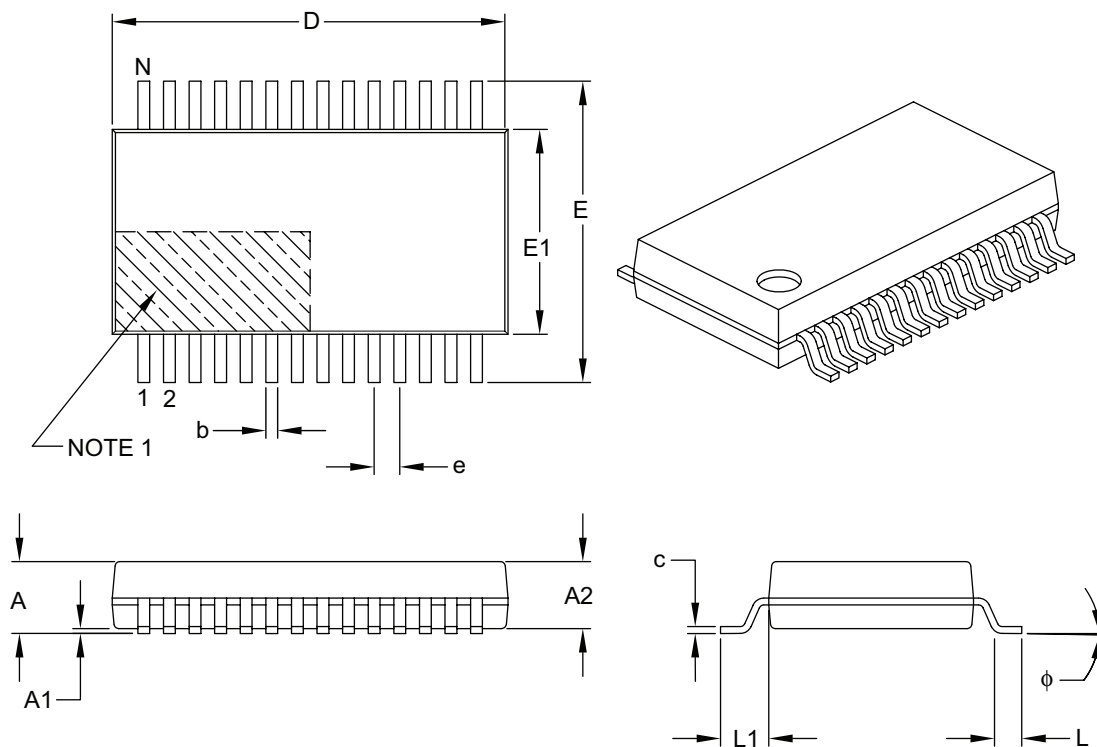

Dimension Limits	Units	MILLIMETERS		
		MIN	NOM	MAX
Number of Pins	N	28		
Pitch	e	0.65 BSC		
Overall Height	A	–	–	2.00
Molded Package Thickness	A2	1.65	1.75	1.85
Standoff	A1	0.05	–	–
Overall Width	E	7.40	7.80	8.20
Molded Package Width	E1	5.00	5.30	5.60
Overall Length	D	9.90	10.20	10.50
Foot Length	L	0.55	0.75	0.95
Footprint	L1	1.25 REF		
Lead Thickness	c	0.09	–	0.25
Foot Angle	φ	0°	4°	8°
Lead Width	b	0.22	–	0.38

**Notes:**

- Pin 1 visual index feature may vary, but must be located within the hatched area.
- Dimensions D and E1 do not include mold flash or protrusions. Mold flash or protrusions shall not exceed 0.20 mm per side.
- Dimensioning and tolerancing per ASME Y14.5M.

BSC: Basic Dimension. Theoretically exact value shown without tolerances.

REF: Reference Dimension, usually without tolerance, for information purposes only.

---



---

## Footprint Outlines and Dimensions

---



---

### 28-Lead Plastic Shrink Small Outline (SS) - 5.30 mm Body [SSOP]

**Note:** For the most current package drawings, please see the Microchip Packaging Specification located at <http://www.microchip.com/packaging>

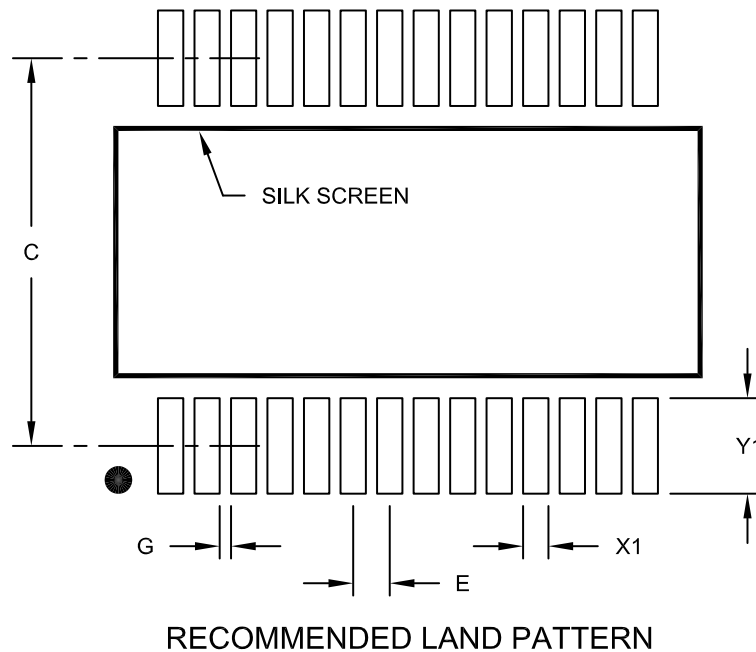

		Units	MILLIMETERS		
Dimension Limits			MIN	NOM	MAX
Contact Pitch	E		0.65 BSC		
Contact Pad Spacing	C			7.20	
Contact Pad Width (X28)	X1				0.45
Contact Pad Length (X28)	Y1				1.75
Distance Between Pads	G	0.20			

**Notes:**

1. Dimensioning and tolerancing per ASME Y14.5M

BSC: Basic Dimension. Theoretically exact value shown without tolerances.

Microchip Technology Drawing No. C04-2073A



**MICROCHIP**

---

---

**Package Outlines and Dimensions**

---

---

NOTES:

---

---

**Package Outlines and Dimensions**

---

---

**TSSOP**

**Package Outlines and Dimensions**

**8-Lead Plastic Thin Shrink Small Outline (ST) – 4.4 mm Body [TSSOP]**

**Note:** For the most current package drawings, please see the Microchip Packaging Specification located at <http://www.microchip.com/packaging>

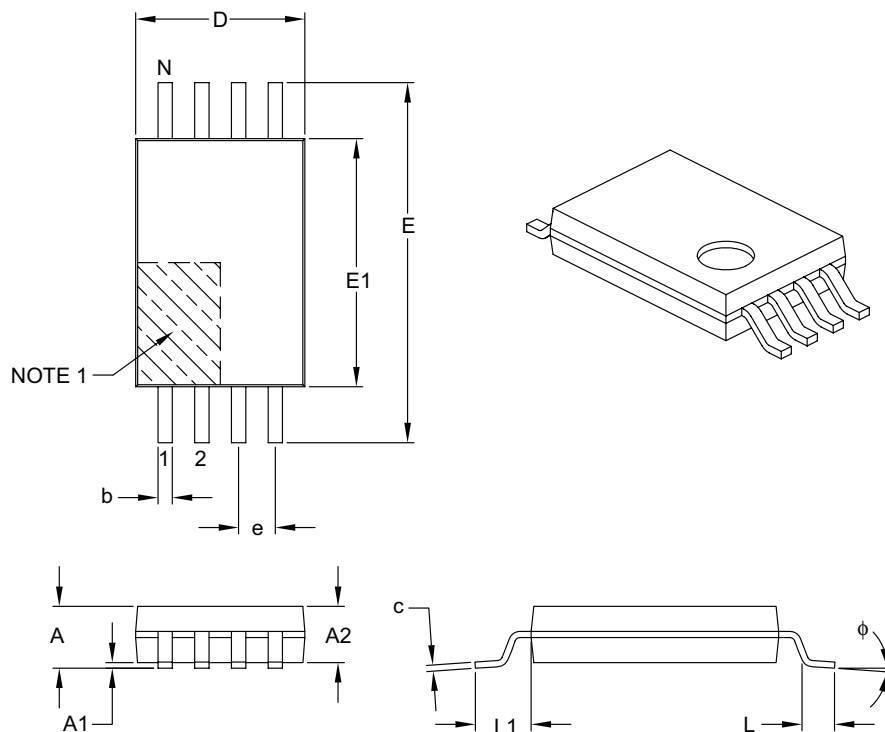

Dimension Limits	Units	MILLIMETERS		
		MIN	NOM	MAX
Number of Pins	N	8		
Pitch	e	0.65 BSC		
Overall Height	A	–	–	1.20
Molded Package Thickness	A2	0.80	1.00	1.05
Standoff	A1	0.05	–	0.15
Overall Width	E	6.40 BSC		
Molded Package Width	E1	4.30	4.40	4.50
Molded Package Length	D	2.90	3.00	3.10
Foot Length	L	0.45	0.60	0.75
Footprint	L1	1.00 REF		
Foot Angle	$\phi$	0°	–	8°
Lead Thickness	c	0.09	–	0.20
Lead Width	b	0.19	–	0.30

**Notes:**

- Pin 1 visual index feature may vary, but must be located within the hatched area.
- Dimensions D and E1 do not include mold flash or protrusions. Mold flash or protrusions shall not exceed 0.15 mm per side.
- Dimensioning and tolerancing per ASME Y14.5M.

BSC: Basic Dimension. Theoretically exact value shown without tolerances.

REF: Reference Dimension, usually without tolerance, for information purposes only.

---



---

## Footprint Outlines and Dimensions

---



---

### 8-Lead Plastic Thin Shrink Small Outline (ST) - 4.4 mm Body [TSSOP]

**Note:** For the most current package drawings, please see the Microchip Packaging Specification located at <http://www.microchip.com/packaging>

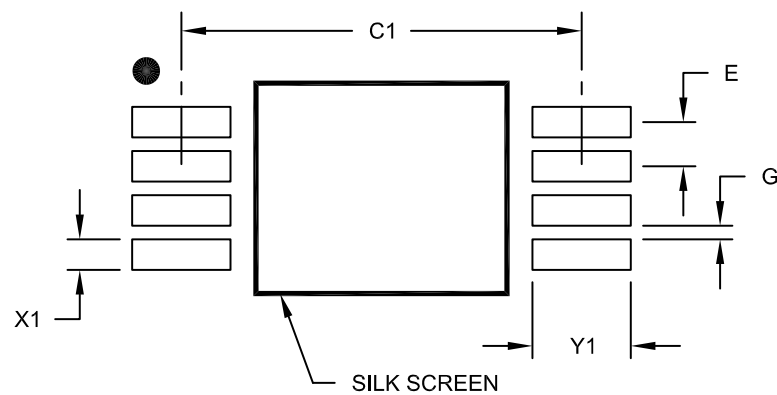

### RECOMMENDED LAND PATTERN

Units		MILLIMETERS		
Dimension Limits		MIN	NOM	MAX
Contact Pitch	E	0.65 BSC		
Contact Pad Spacing	C1		5.90	
Contact Pad Width (X8)	X1			0.45
Contact Pad Length (X8)	Y1			1.45
Distance Between Pads	G	0.20		

**Notes:**

1. Dimensioning and tolerancing per ASME Y14.5M

BSC: Basic Dimension. Theoretically exact value shown without tolerances.

Microchip Technology Drawing No. C04-2086A

**Package Outlines and Dimensions**

**14-Lead Plastic Thin Shrink Small Outline (ST) - 4.4 mm Body [TSSOP]**

**Note:** For the most current package drawings, please see the Microchip Packaging Specification located at <http://www.microchip.com/packaging>

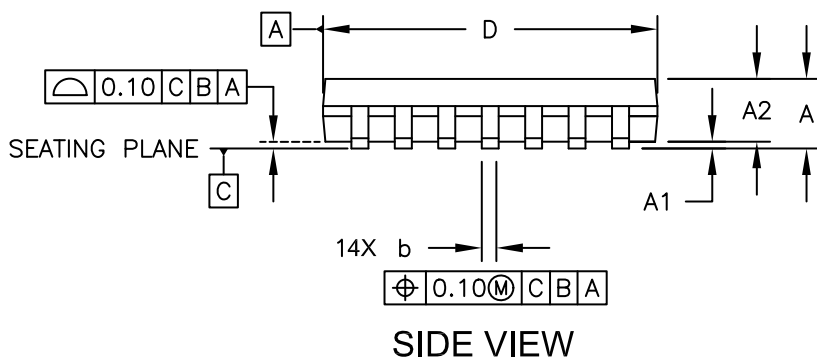
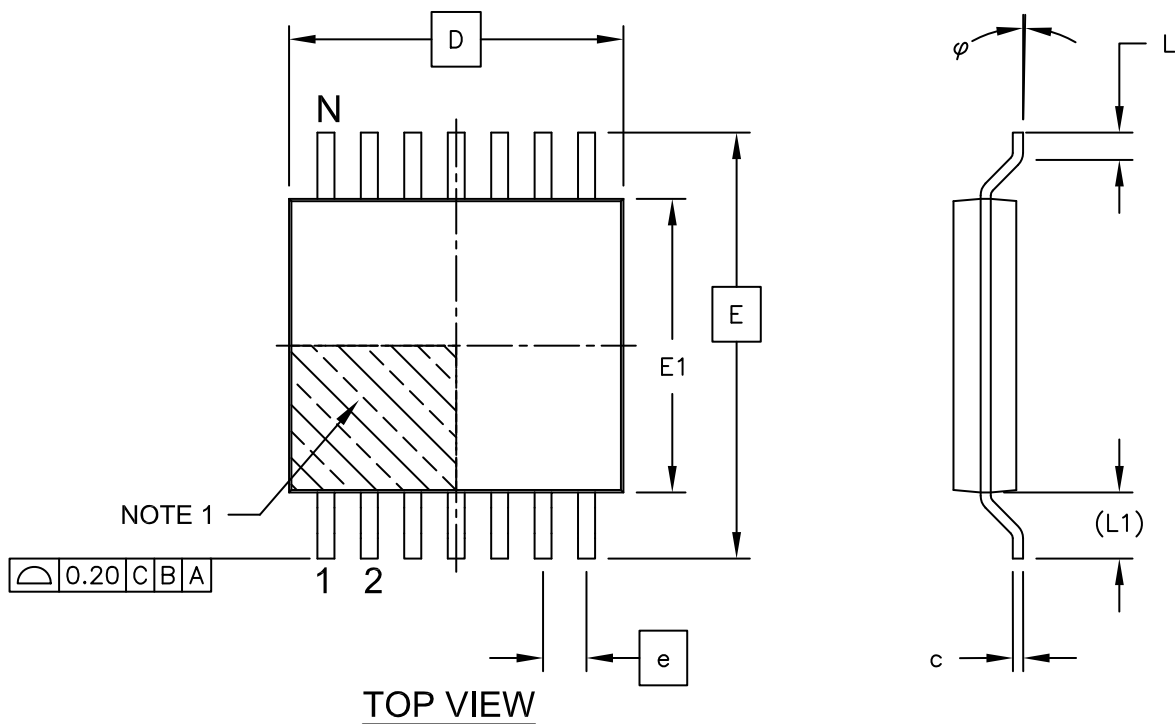



---



---

## Package Outlines and Dimensions

---



---

### 14-Lead Plastic Thin Shrink Small Outline (ST) - 4.4 mm Body [TSSOP]

**Note:** For the most current package drawings, please see the Microchip Packaging Specification located at <http://www.microchip.com/packaging>

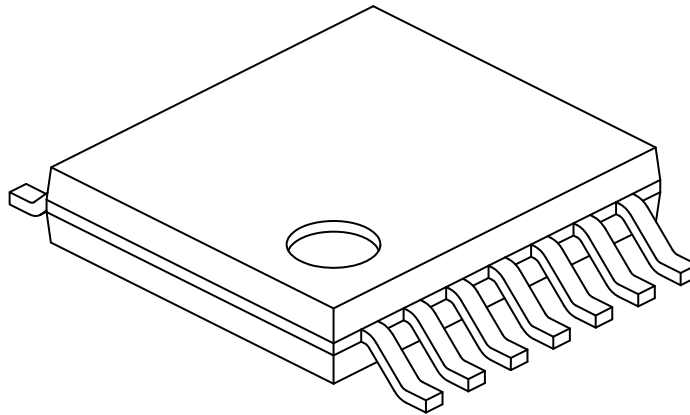

		Units	MILLIMETERS		
Dimension Limits			MIN	NOM	MAX
Number of Pins	N		14		
Pitch	e		0.65 BSC		
Overall Height	A	-	-	-	1.20
Molded Package Thickness	A2	0.80	1.00	1.05	
Standoff	A1	0.05	-	0.15	
Overall Width	E		6.40 BSC		
Molded Package Width	E1	4.30	4.40	4.50	
Molded Package Length	D	4.90	5.00	5.10	
Foot Length	L	0.45	0.60	0.75	
Footprint	(L1)		1.00 REF		
Foot Angle	$\varphi$	0°	-	8°	
Lead Thickness	c	0.09	-	0.20	
Lead Width	b	0.19	-	0.30	

**Notes:**

1. Pin 1 visual index feature may vary, but must be located within the hatched area.
2. Dimensions D and E1 do not include mold flash or protrusions. Mold flash or protrusions shall not exceed 0.15mm per side.
3. Dimensioning and tolerancing per ASME Y14.5M
  - BSC: Basic Dimension. Theoretically exact value shown without tolerances.
  - REF: Reference Dimension, usually without tolerance, for information purposes only.

**Footprint Outlines and Dimensions**

**14-Lead Plastic Thin Shrink Small Outline (ST) - 4.4 mm Body [TSSOP]**

**Note:** For the most current package drawings, please see the Microchip Packaging Specification located at <http://www.microchip.com/packaging>

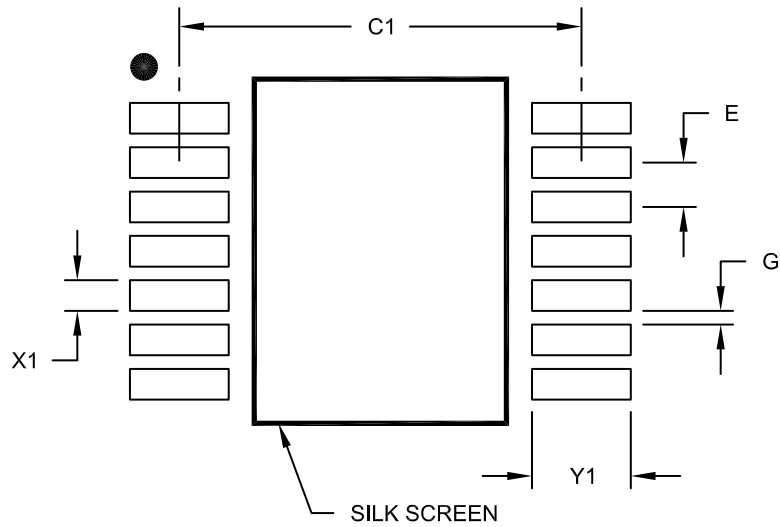

**RECOMMENDED LAND PATTERN**

Dimension Limits	Units	MILLIMETERS		
		MIN	NOM	MAX
Contact Pitch	E	0.65 BSC		
Contact Pad Spacing	C1		5.90	
Contact Pad Width (X14)	X1			0.45
Contact Pad Length (X14)	Y1			1.45
Distance Between Pads	G	0.20		

Notes:

1. Dimensioning and tolerancing per ASME Y14.5M

BSC: Basic Dimension. Theoretically exact value shown without tolerances.

Microchip Technology Drawing No. C04-2087A

**Package Outlines and Dimensions**

**16-Lead Plastic Thin Shrink Small Outline (ST) – 4.4 mm Body [TSSOP]**

**Note:** For the most current package drawings, please see the Microchip Packaging Specification located at <http://www.microchip.com/packaging>

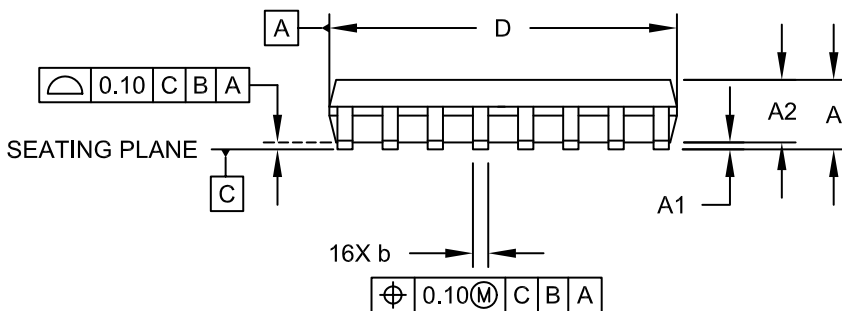
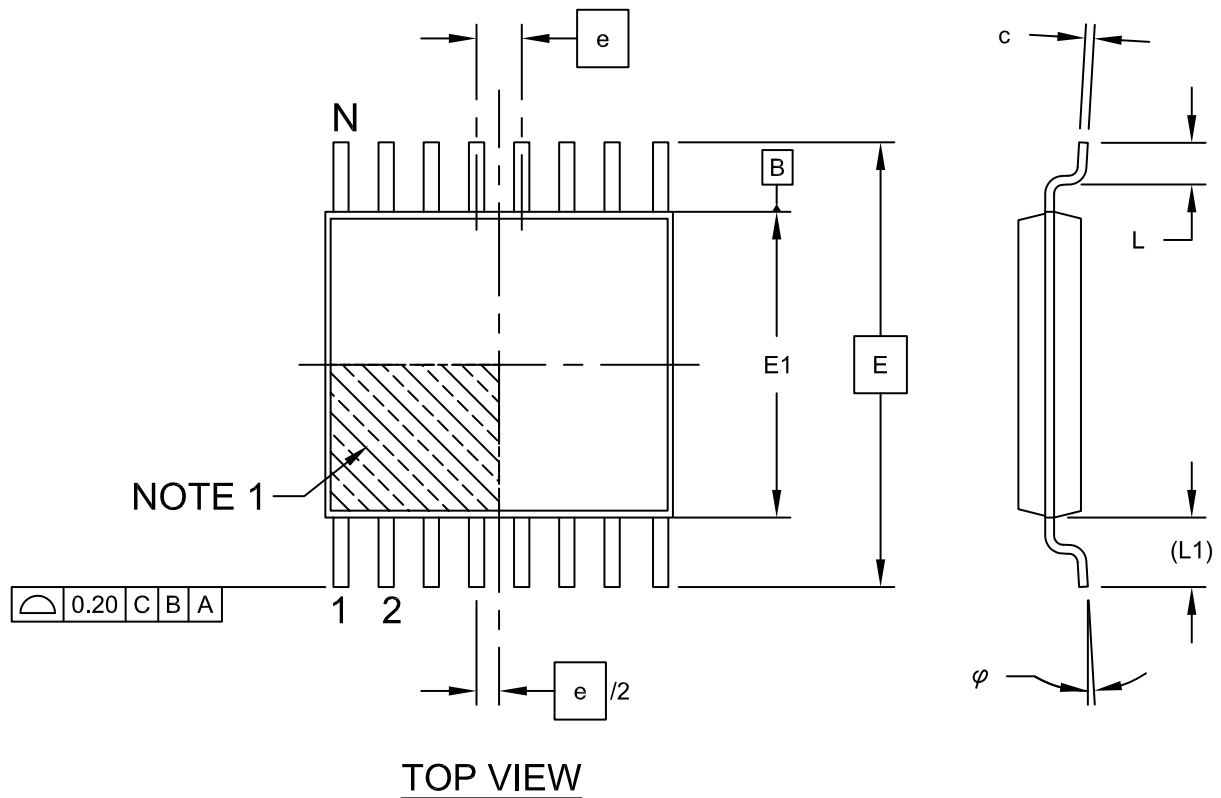

---



---

**Package Outlines and Dimensions**

---



---

**16-Lead Plastic Thin Shrink Small Outline (ST) – 4.4 mm Body [TSSOP]**

**Note:** For the most current package drawings, please see the Microchip Packaging Specification located at <http://www.microchip.com/packaging>

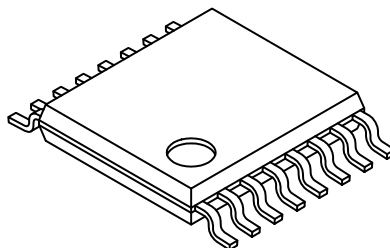

		MILLIMETERS		
Units				
Dimension Limits		MIN	NOM	MAX
Number of Pins	N	16		
Pitch	e	0.65 BSC		
Overall Height	A	-	-	1.20
Molded Package Thickness	A2	0.80	1.00	1.05
Standoff	A1	0.05	-	0.15
Overall Width	E	6.40 BSC		
Molded Package Width	E1	4.30	4.40	4.50
Molded Package Length	D	4.90	5.00	5.10
Foot Length	L	0.45	0.60	0.75
Footprint	(L1)	1.00 REF		
Foot Angle	$\varphi$	0°	-	8°
Lead Thickness	c	0.09	-	0.20
Lead Width	b	0.19	-	0.30

**Notes:**

1. Pin 1 visual index feature may vary, but must be located within the hatched area.
2. Dimensions D and E1 do not include mold flash or protrusions. Mold flash or protrusions shall not exceed 0.15mm per side.
3. Dimensioning and tolerancing per ASME Y14.5M
  - BSC: Basic Dimension. Theoretically exact value shown without tolerances.
  - REF: Reference Dimension, usually without tolerance, for information purposes only.

---



---

## Footprint Outlines and Dimensions

---



---

### 16-Lead Plastic Thin Shrink Small Outline (ST) – 4.4 mm Body [TSSOP]

**Note:** For the most current package drawings, please see the Microchip Packaging Specification located at <http://www.microchip.com/packaging>

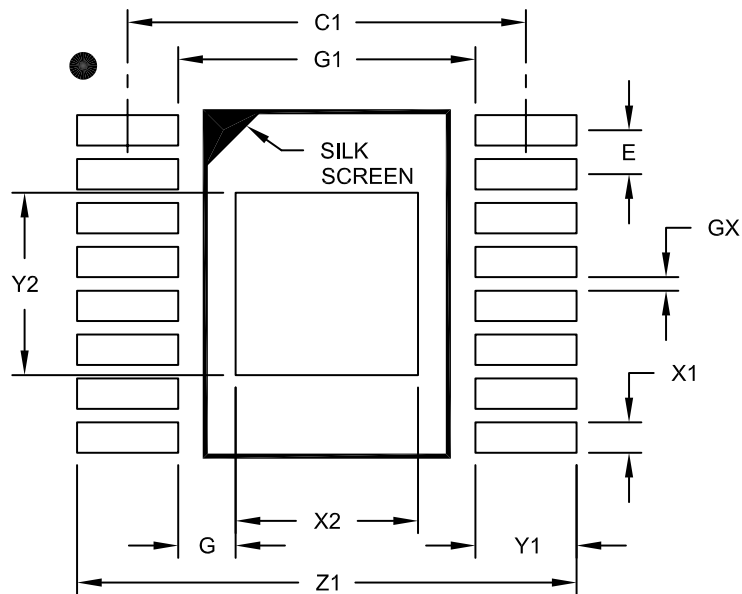

RECOMMENDED LAND PATTERN

Dimension Limits	Units	MILLIMETERS		
		MIN	NOM	MAX
Contact Pitch	E	0.65 BSC		
Optional Center Pad Length	Y2			2.70
Optional Center Pad Width	X2			2.70
Clearance Between Contact Pads	G1	4.40		
Contact Pad To Center Pad	G	0.73		
Contact Pad Spacing	C1		5.90	
Contact Pad Width (X16)	X1			0.45
Contact Pad Length (X16)	Y1			1.50
Distance Between Pads	GX	0.20		
Overall Width	Z1			7.40

**Notes:**

1. Dimensioning and tolerancing per ASME Y14.5M

BSC: Basic Dimension. Theoretically exact value shown without tolerances.

Microchip Technology Drawing No. C04-2068A

**Package Outlines and Dimensions**

**20-Lead Plastic Thin Shrink Small Outline (ST) - 4.4 mm Body [TSSOP]**

**Note:** For the most current package drawings, please see the Microchip Packaging Specification located at <http://www.microchip.com/packaging>

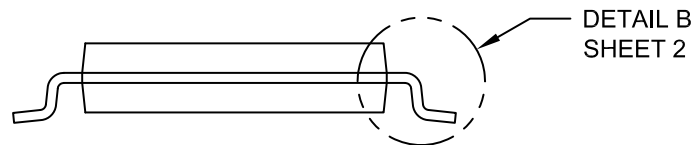
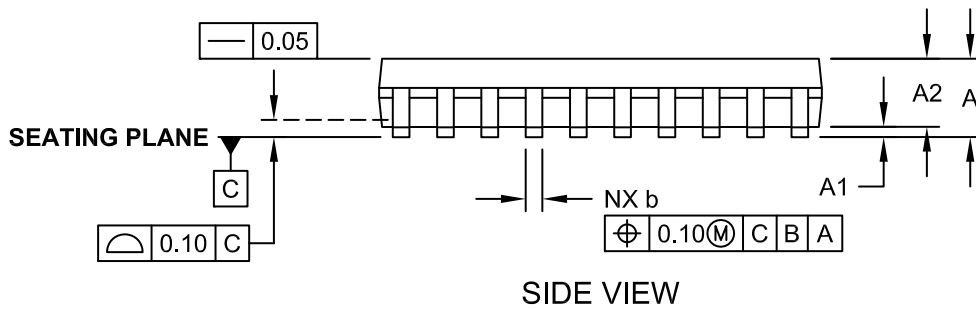
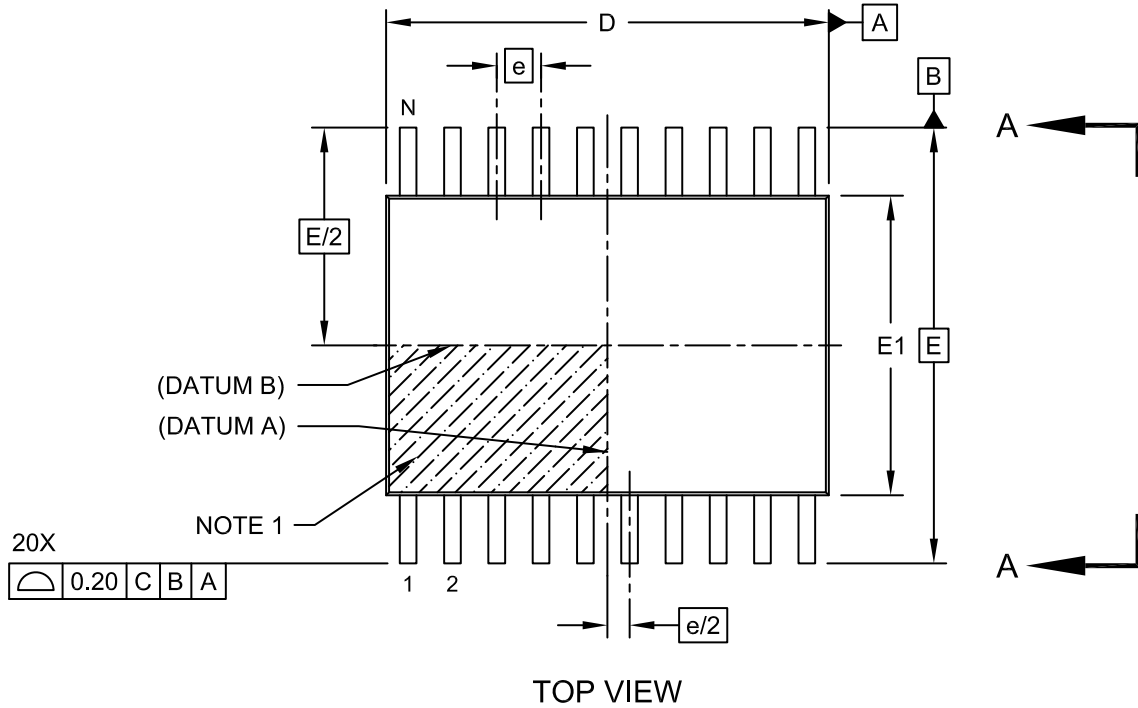

---



---

## Footprint Outlines and Dimensions

---



---

### 20-Lead Plastic Thin Shrink Small Outline (ST) - 4.4 mm Body [TSSOP]

**Note:** For the most current package drawings, please see the Microchip Packaging Specification located at <http://www.microchip.com/packaging>

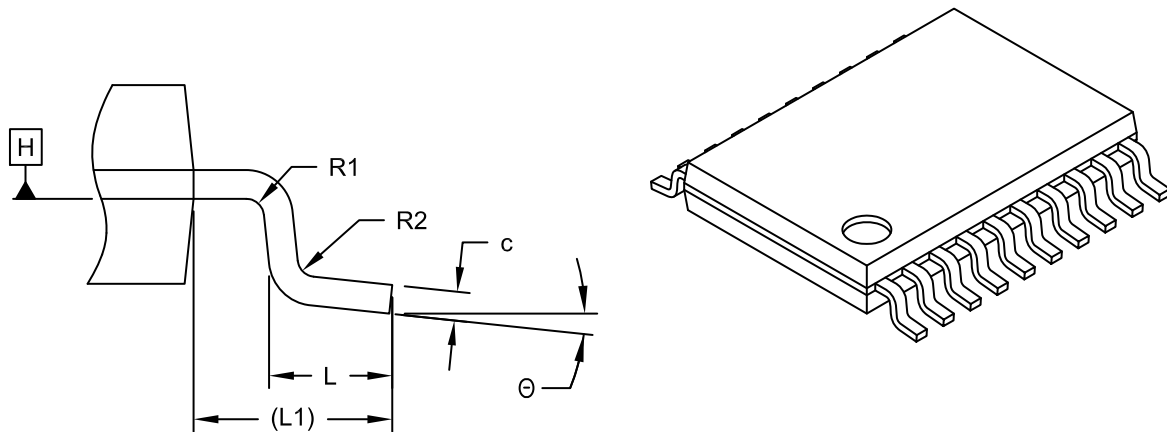

DETAIL B

Dimension Limits	Units	MILLIMETERS		
		MIN	NOM	MAX
Number of Pins	N	20		
Pitch	e	0.65 BSC		
Overall Height	A	-	-	1.20
Molded Package Thickness	A2	0.80	1.00	1.05
Standoff	A1	0.05	-	0.15
Overall Width	E	6.40 BSC		
Molded Package Width	E1	4.30	4.40	4.50
Molded Package Length	D	6.40	6.50	6.60
Foot Length	L	0.45	0.60	0.75
Footprint	L1	1.00 REF		
Foot Angle	Θ	0°	-	8°
Lead Width	b	0.19	-	0.30
Lead Thickness	c	0.09	-	0.20
Bend Radius	R1	0.09	-	-
Bend Radius	R2	0.09	-	-

Notes:

1. Pin 1 visual index feature may vary, but must be located within the hatched area.
2. Dimensions D and E1 do not include mold flash or protrusions. Mold flash or protrusions shall not exceed 0.15mm per side.
3. Dimensioning and tolerancing per ASME Y14.5M
  - BSC: Basic Dimension. Theoretically exact value shown without tolerances.
  - REF: Reference Dimension, usually without tolerance, for information purposes only.

**Footprint Outlines and Dimensions**

**20-Lead Plastic Thin Shrink Small Outline (ST) - 4.4 mm Body [TSSOP]**

**Note:** For the most current package drawings, please see the Microchip Packaging Specification located at <http://www.microchip.com/packaging>

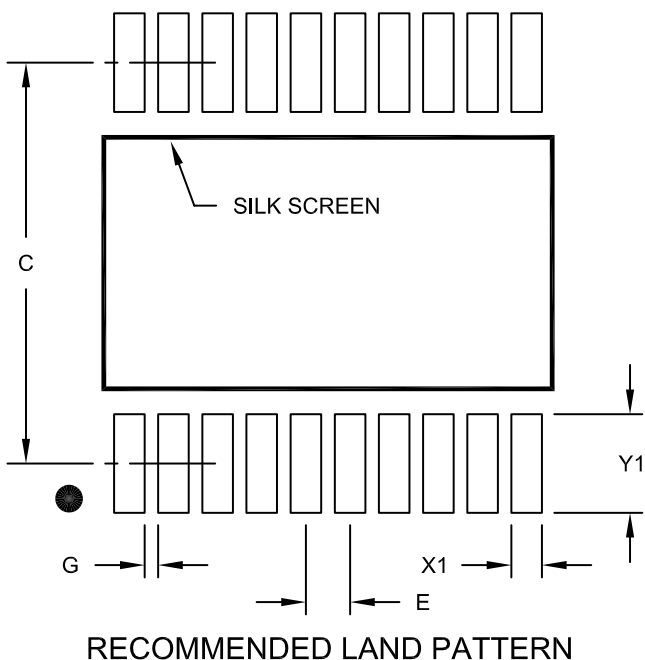

Dimension Limits	Units	MILLIMETERS		
		MIN	NOM	MAX
Contact Pitch	E	0.65 BSC		
Contact Pad Spacing	C		5.90	
Contact Pad Width (X20)	X1			0.45
Contact Pad Length (X20)	Y1			1.45
Distance Between Pads	G	0.20		

Notes:

1. Dimensioning and tolerancing per ASME Y14.5M

BSC: Basic Dimension. Theoretically exact value shown without tolerances.

Microchip Technology Drawing No. C04-2088A



**Package Outlines and Dimensions**

**38-Lead Thin Shrink Small Outline Package (SBX) - 4.4 mm Body [TSSOP]  
With 4.6x 3.2 mm Exposed Pad**

**Note:** For the most current package drawings, please see the Microchip Packaging Specification located at <http://www.microchip.com/packaging>

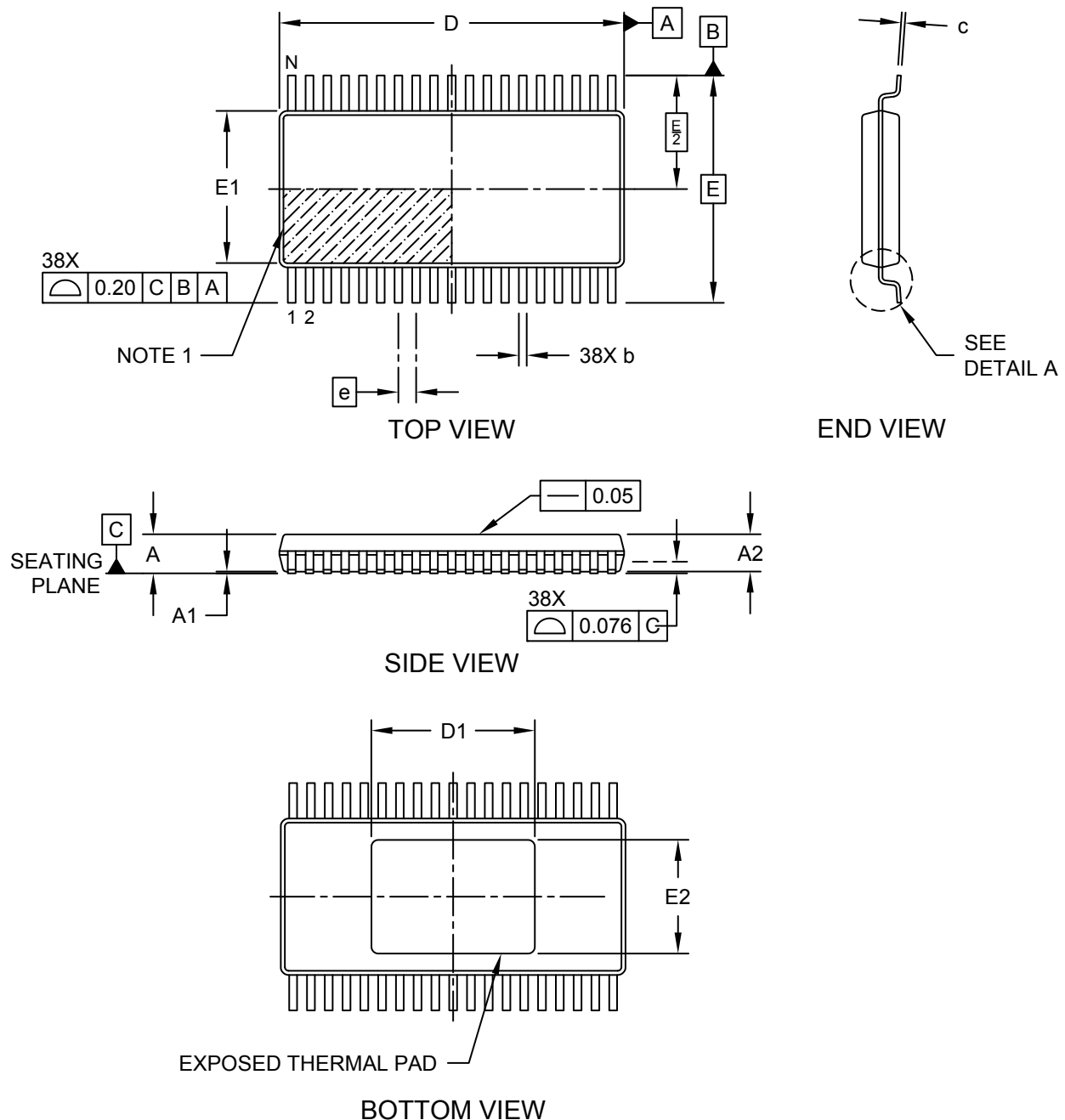

**Package Outlines and Dimensions**

**38-Lead Thin Shrink Small Outline Package (SBX) - 4.4 mm Body [TSSOP]  
With 4.6x 3.2 mm Exposed Pad**

**Note:** For the most current package drawings, please see the Microchip Packaging Specification located at <http://www.microchip.com/packaging>

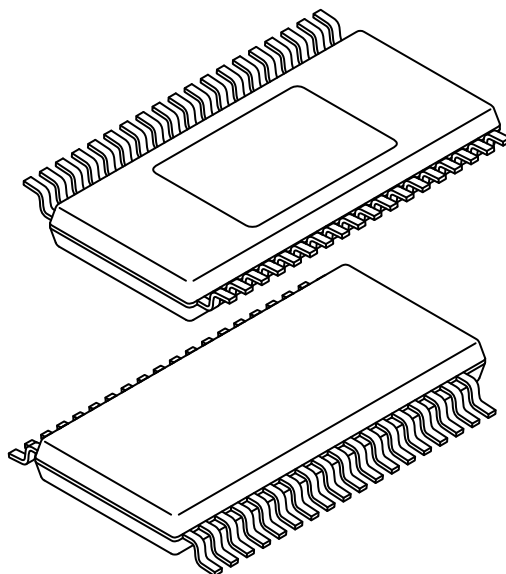
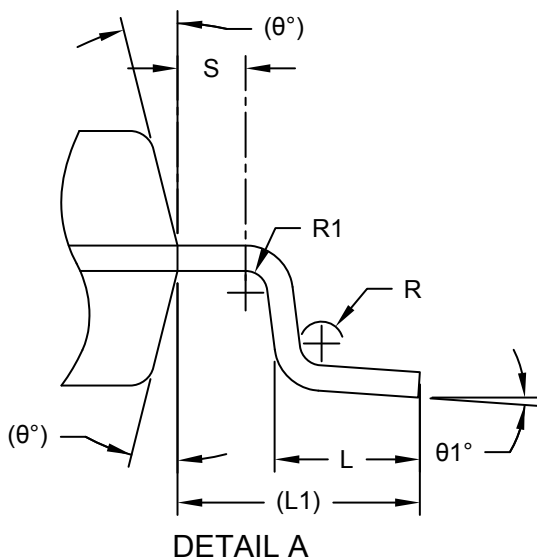

		Units	MILLIMETERS		
Dimension Limits			MIN	NOM	MAX
Number of Terminals	N		38		
Pitch	e		0.50 BSC		
Overall Height	A	-	-	-	1.10
Standoff	A1	0.05	-	-	0.15
Terminal Thickness	A2	0.85	0.90	-	0.95
Overall Length	D	9.60	9.70	-	9.80
Exposed Pad Length	D1	4.50	4.60	-	4.70
Overall Width	E		6.40 BSC		
Molded Package Width	E1	4.30	4.40	-	4.60
Exposed Pad Width	E2	3.10	3.20	-	3.30
Terminal Width	b	0.17	-	-	0.27
Terminal Width	c	0.09	-	-	0.20
Terminal Length	L	0.50	0.60	-	0.70
Terminal Length	L1		1.00 REF		
Lead Shoulder	S	0.20	-	-	-
Terminal Foot Angle	θ1	0°	-	-	8°
Mold Draft Angle	θ		14° REF		

**Notes:**

- Pin 1 visual index feature may vary, but must be located within the hatched area.
- Dimensioning and tolerancing per ASME Y14.5M

BSC: Basic Dimension. Theoretically exact value shown without tolerances.

REF: Reference Dimension, usually without tolerance, for information purposes only.

---



---

## Footprint Outlines and Dimensions

---



---

### 38-Lead Thin Shrink Small Outline Package (SBX) - 4.4 mm Body [TSSOP] With 4.6x 3.2 mm Exposed Pad

**Note:** For the most current package drawings, please see the Microchip Packaging Specification located at <http://www.microchip.com/packaging>

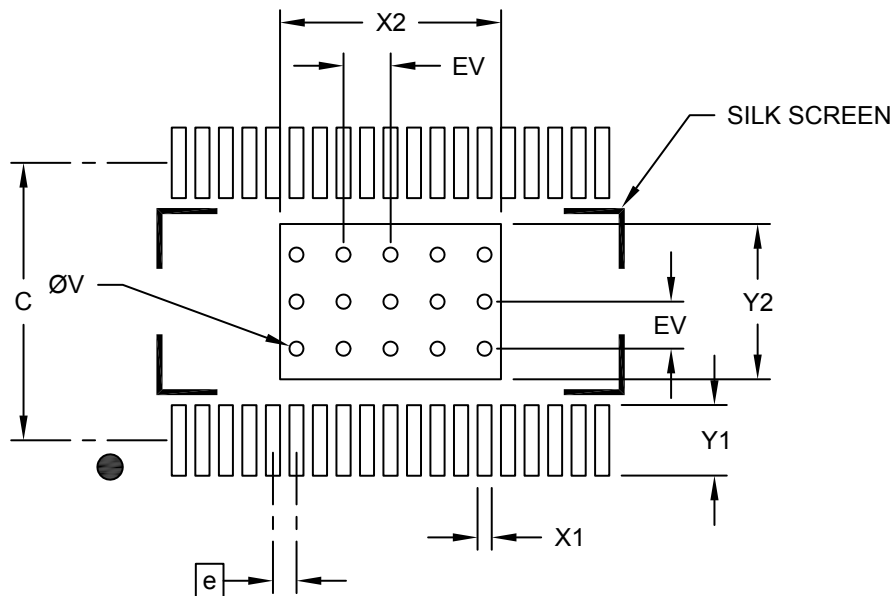

### RECOMMENDED LAND PATTERN

Units		MILLIMETERS		
Dimension Limits		MIN	NOM	MAX
Contact Pitch	E	0.50 BSC		
Center Pad Width	X2			4.70
Center Pad Length	Y2			3.30
Contact Pad Spacing	C		5.90	
Contact Pad Width (X38)	X1			0.30
Contact Pad Length (X38)	Y1			1.50
Thermal Via Diameter	V		0.30	
Thermal Via Pitch	EV		1.00	

**Notes:**

1. Dimensioning and tolerancing per ASME Y14.5M  
BSC: Basic Dimension. Theoretically exact value shown without tolerances.
2. For best soldering results, thermal vias, if used, should be filled or tented to avoid solder loss during reflow process



**MICROCHIP**

---

---

**Package Outlines and Dimensions**

---

---

**NOTES:**

---

---

**Package Outlines and Dimensions**

---

---

**TSOP**

**Package Outlines and Dimensions**

**28-Lead Plastic Thin Small Outline (TS) – 8x20 mm [TSOP]**

**Note:** For the most current package drawings, please see the Microchip Packaging Specification located at <http://www.microchip.com/packaging>

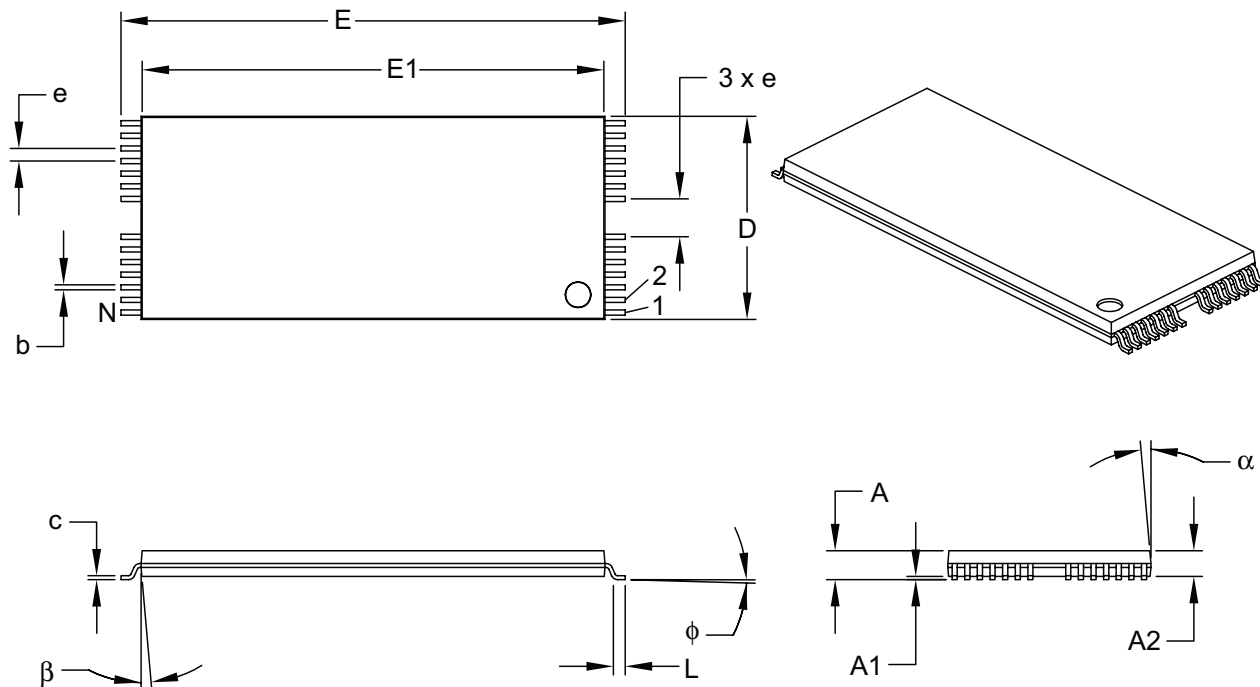

Dimension Limits	Units	MILLIMETERS		
		MIN	NOM	MAX
Number of Pins	N	28		
Pitch	e	0.50		
Overall Height	A	0.99	1.14	1.30
Molded Package Thickness	A2	0.95	1.00	1.05
Standoff §	A1	0.05	0.15	0.25
Overall Width	E	19.80	20.00	20.20
Molded Package Width	E1	18.30	18.40	18.50
Molded Package Length	D	7.80	8.00	8.20
Foot Length	L	0.50	0.60	0.70
Foot Angle	φ	0°	4°	8°
Lead Thickness	c	0.10	0.15	0.20
Lead Width	b	0.15	0.20	0.25
Mold Draft Angle Top	α	0°	5°	10°
Mold Draft Angle Bottom	β	0°	5°	10°

**Notes:**

- Dimensions D and E1 do not include mold flash or protrusions. Mold flash or protrusions shall not exceed 0.127 mm per side.
- § Significant Characteristic.

Microchip Technology Drawing C04-067B

**Package Outlines and Dimensions**

**48-LEAD THIN SMALL OUTLINE PACKAGE (TV) - 12x20 mm Body [TSOP]**

**Note:** For the most current package drawings, please see the Microchip Packaging Specification located at <http://www.microchip.com/packaging>

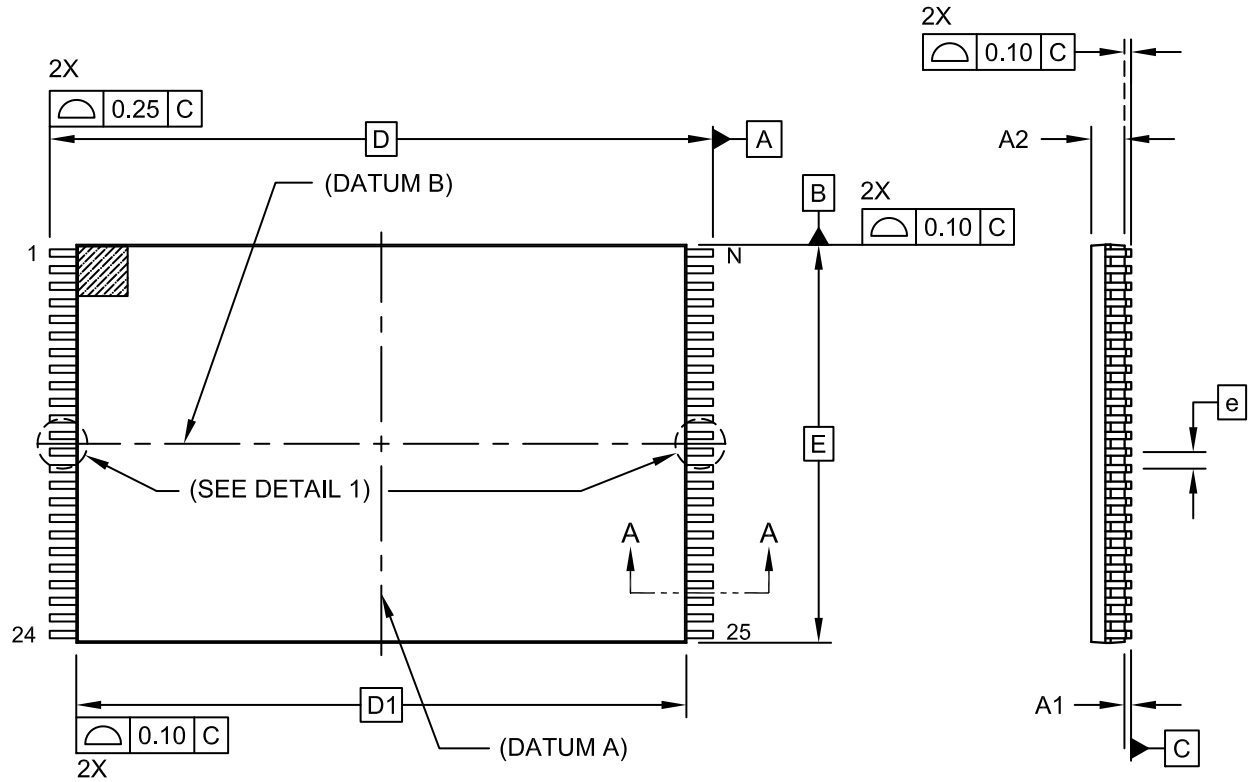

TOP VIEW

END VIEW

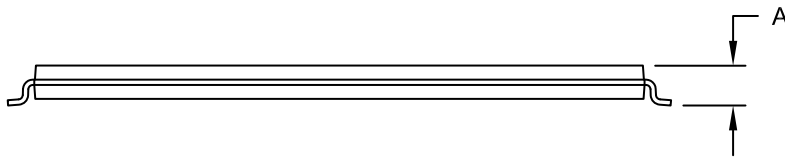

SIDE VIEW

**Package Outlines and Dimensions**

**48-LEAD THIN SMALL OUTLINE PACKAGE (TV) - 12x20 mm Body [TSOP]**

**Note:** For the most current package drawings, please see the Microchip Packaging Specification located at <http://www.microchip.com/packaging>

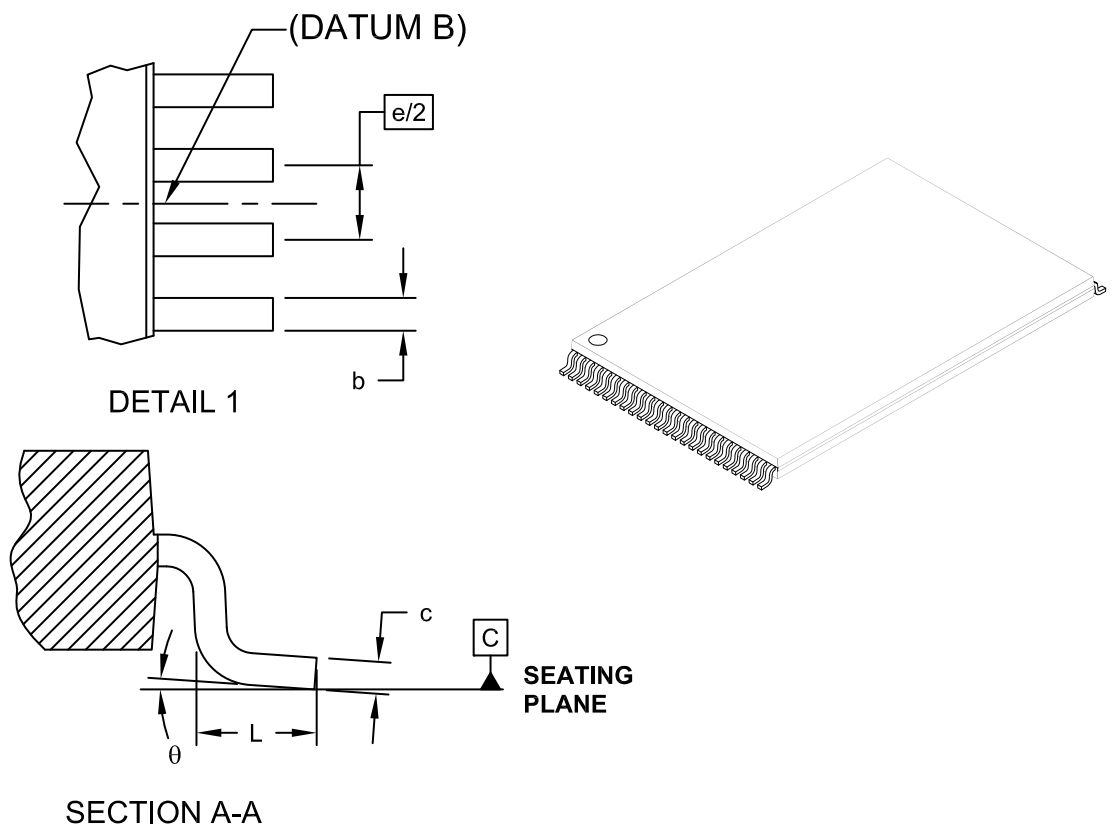

Dimension Limits	Units	MILLIMETERS		
		MIN	NOM	MAX
Number of Pins	N	48		
Pitch	e	0.50 BSC		
Overall Height	A	-	-	1.20
Standoff	A1	0.05	-	0.15
Molded Package Height	A2	0.95	1.00	1.05
Overall Width	E	12.00 BSC		
Overall Length	D	20.00 BSC		
Molded Package Length	D1	18.40 BSC		
Lead Width	b	0.17	0.22	0.27
Lead Thickness	c	0.10	-	0.21
Lead Length	L	0.50	0.60	0.70
Lead Foot Angle	θ	0°	5°	8°

- Notes:
- Pin 1 visual index feature may vary, but must be located within the hatched area.
  - Dimensioning and tolerancing per ASME Y14.5M
- BSC: Basic Dimension. Theoretically exact value shown without tolerances.  
 REF: Reference Dimension, usually without tolerance, for information purposes only.



---

---

**Package Outlines and Dimensions**

---

---

**VSOP**

## Package Outlines and Dimensions

### 28-Lead Plastic Very Small Outline (VS) – 8x13.4 mm Body [VSOP]

**Note:** For the most current package drawings, please see the Microchip Packaging Specification located at <http://www.microchip.com/packaging>

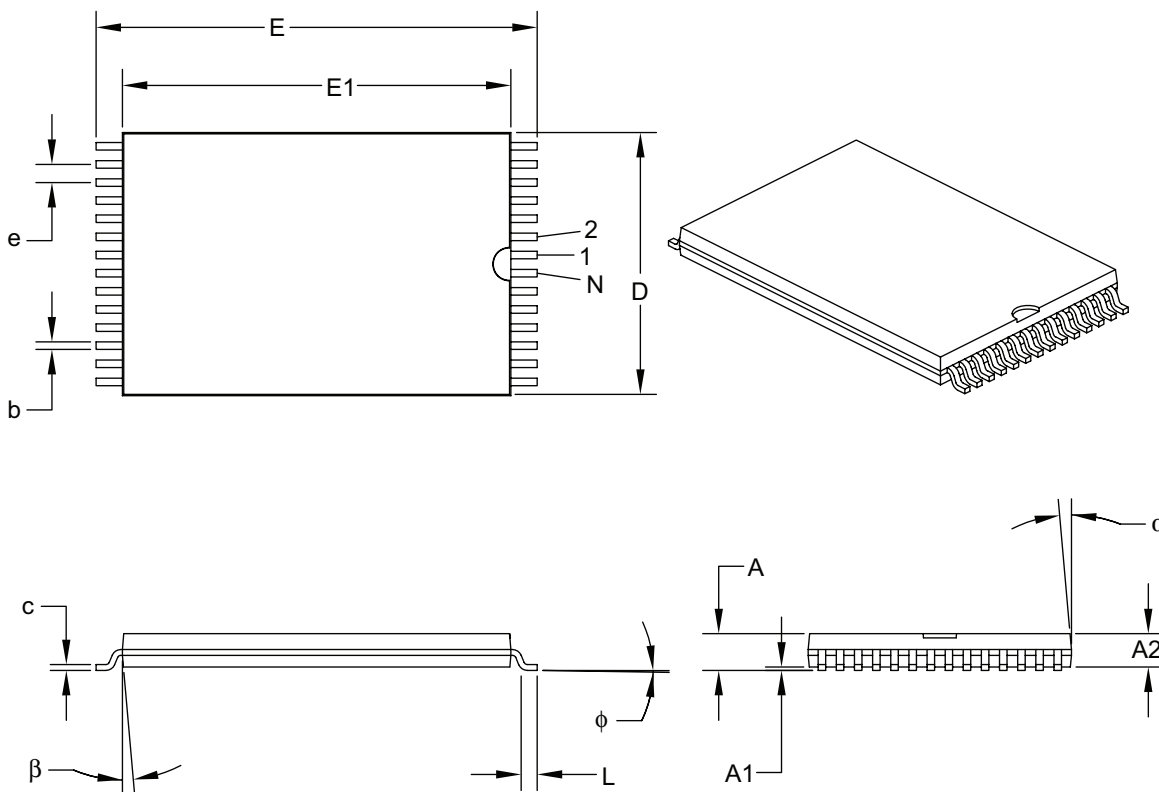

Dimension Limits	Units	MILLIMETERS		
		MIN	NOM	MAX
Number of Pins	N	28		
Pitch	e	0.55		
Overall Height	A	0.99	1.14	1.29
Molded Package Thickness	A2	0.95	1.00	1.05
Standoff §	A1	0.05	0.13	0.25
Overall Width	E	13.20	13.40	13.60
Molded Package Width	E1	11.70	11.80	11.90
Molded Package Length	D	7.90	8.00	8.10
Foot Length	L	0.30	0.50	0.70
Foot Angle	$\phi$	0°	3°	5°
Lead Thickness	c	0.14	0.15	0.16
Lead Width	b	0.17	0.20	0.23
Mold Draft Angle Top	$\alpha$	0°	5°	10°
Mold Draft Angle Bottom	$\beta$	0°	5°	10°

**Notes:**

- § Significant Characteristic.
- Dimensions D and E1 do not include mold flash or protrusions. Mold flash or protrusions shall not exceed 0.127 mm per side.

Microchip Technology Drawing C04-075B

---

---

**Package Outlines and Dimensions**

---

---

**LQFP**

**Package Outlines and Dimensions**

**32-Lead Plastic Low-Profile Quad Flatpack (PL) – 7x7x1.4 mm Body, 2.0 mm [LQFP]**

**Note:** For the most current package drawings, please see the Microchip Packaging Specification located at <http://www.microchip.com/packaging>

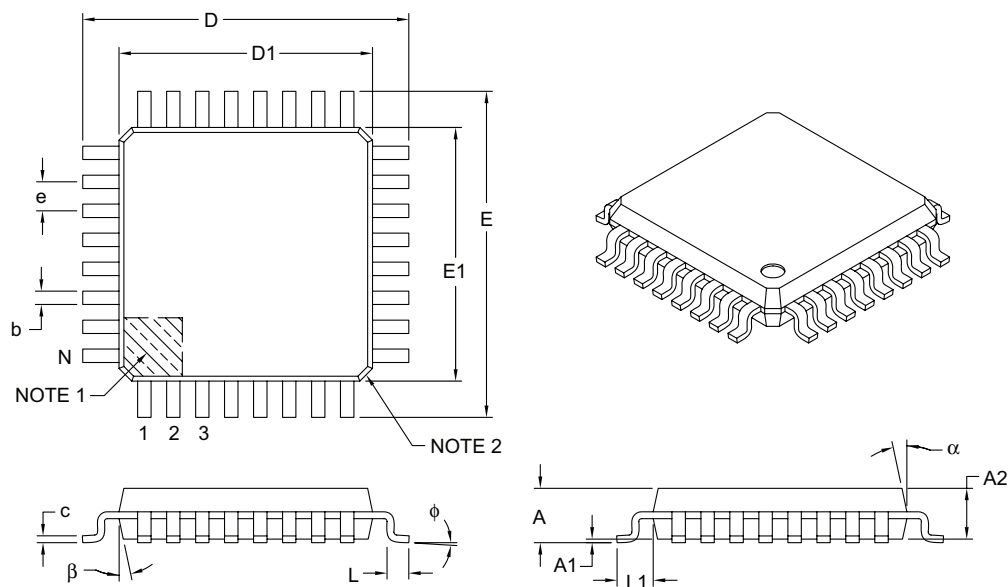

Dimension Limits		Units	MILLIMETERS		
			MIN	NOM	MAX
Number of Leads	N		32		
Lead Pitch	e		0.80 BSC		
Overall Height	A		–	–	1.60
Molded Package Thickness	A2		1.35	1.40	1.45
Standoff	A1		0.05	–	0.15
Foot Length	L		0.45	0.60	0.75
Footprint	L1		1.00 REF		
Foot Angle	φ		0°	3.5°	7°
Overall Width	E		9.00 BSC		
Overall Length	D		9.00 BSC		
Molded Package Width	E1		7.00 BSC		
Molded Package Length	D1		7.00 BSC		
Lead Thickness	c		0.09	–	0.20
Lead Width	b		0.30	0.37	0.45
Mold Draft Angle Top	α		11°	12°	13°
Mold Draft Angle Bottom	β		11°	12°	13°

**Notes:**

- Pin 1 visual index feature may vary, but must be located within the hatched area.
- Chamfers at corners are optional; size may vary.
- Dimensions D1 and E1 do not include mold flash or protrusions. Mold flash or protrusions shall not exceed 0.25 mm per side.
- Dimensioning and tolerancing per ASME Y14.5M.

BSC: Basic Dimension. Theoretically exact value shown without tolerances.

REF: Reference Dimension, usually without tolerance, for information purposes only.

**Package Outlines and Dimensions**

**64-Lead Low Profile Plastic Quad Flatpack (PL) - 10x10 mm Body [LQFP]**

**Note:** For the most current package drawings, please see the Microchip Packaging Specification located at <http://www.microchip.com/packaging>

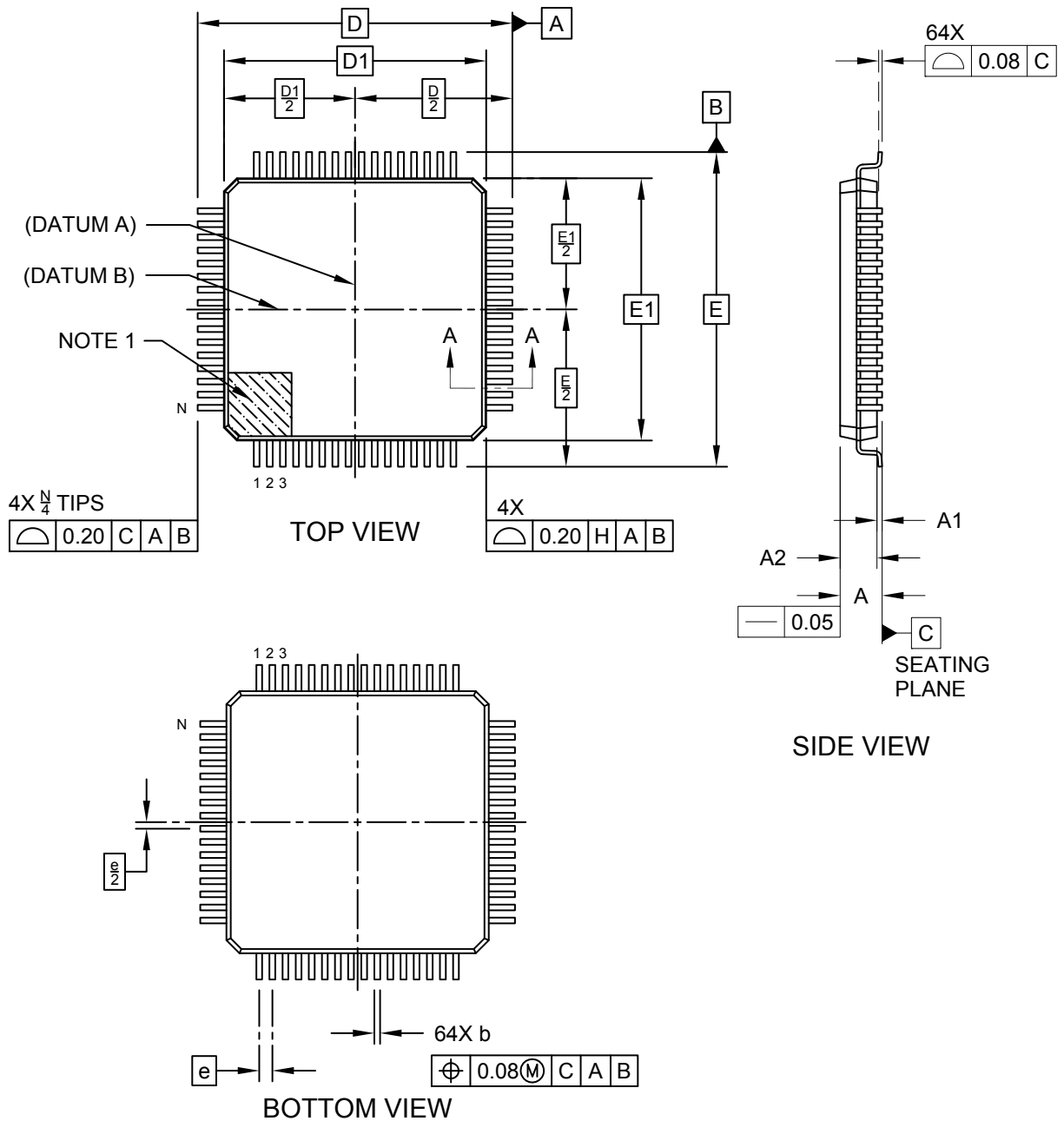

**Package Outlines and Dimensions**

**64-Lead Low Profile Plastic Quad Flatpack (PL) - 10x10 mm Body [LQFP]**

**Note:** For the most current package drawings, please see the Microchip Packaging Specification located at <http://www.microchip.com/packaging>

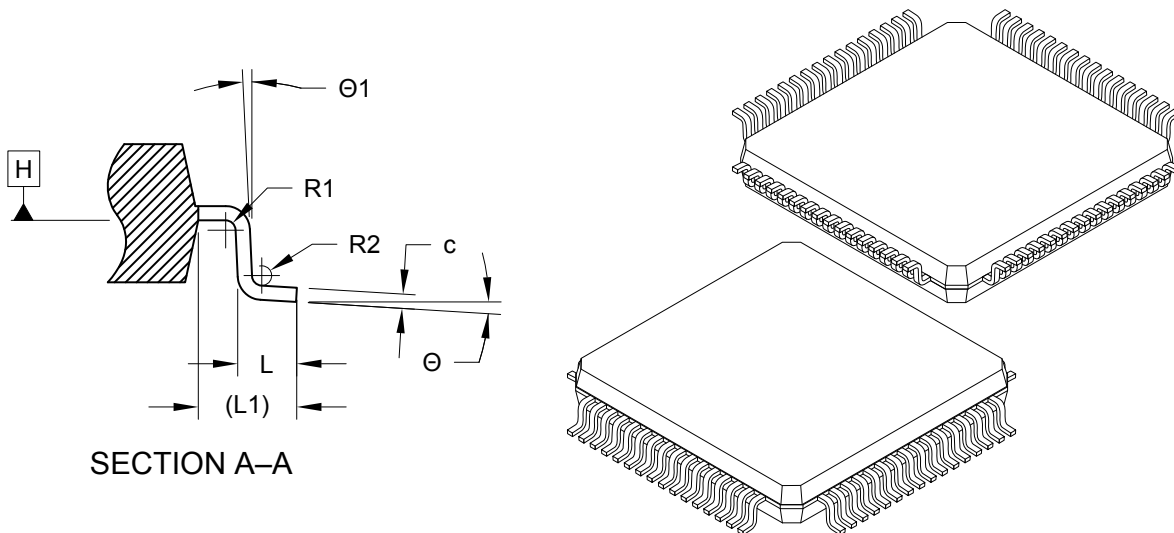

		Units	MILLIMETERS		
Dimension Limits			MIN	NOM	MAX
Number of Terminals	N		64		
Pitch	e		0.50 BSC		
Overall Height	A	-	-	-	1.60
Standoff	A1	0.05	-	-	0.15
Molded Package Thickness	A2	1.35	1.40	-	1.45
Overall Length	D		12.00 BSC		
Molded Package Length	D1		10.00 BSC		
Overall Width	E		12.00 BSC		
Molded Package Width	E1		10.00 BSC		
Terminal Width	b	0.17	0.22	-	0.27
Terminal Thickness	c	0.09	-	-	0.20
Terminal Length	L	0.45	0.60	-	0.75
Footprint	L1		1.00 REF		
Bend Radius	R1	0.08	-	-	-
Bend Radius	R2	0.08	-	-	-
Lead Angle	Θ1	0°	-	-	-
Foot Angle	Θ	0°	3.5°	-	7°

**Notes:**

- Pin 1 visual index feature may vary, but must be located within the hatched area.
- Dimensioning and tolerancing per ASME Y14.5M

BSC: Basic Dimension. Theoretically exact value shown without tolerances.

REF: Reference Dimension, usually without tolerance, for information purposes only.

---



---

## Footprint Outlines and Dimensions

---



---

### 64-Lead Low Profile Plastic Quad Flatpack (PL) - 10x10 mm Body [LQFP]

**Note:** For the most current package drawings, please see the Microchip Packaging Specification located at <http://www.microchip.com/packageing>

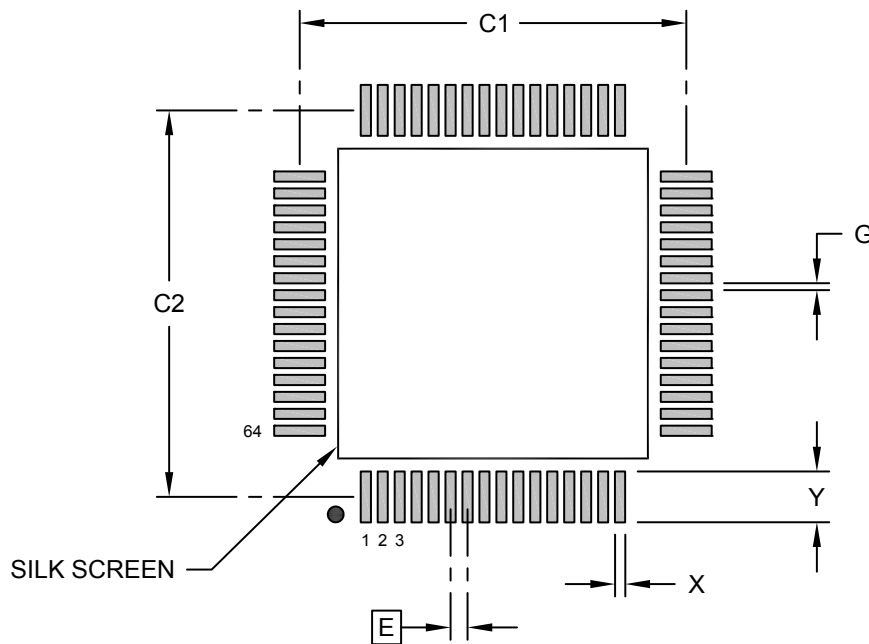

### RECOMMENDED LAND PATTERN

Dimension Limits	Units	MILLIMETERS		
		MIN	NOM	MAX
Contact Pitch	E	0.50 BSC		
Contact Pad Spacing	C1		11.40	
Contact Pad Spacing	C2		11.40	
Contact Pad Width (X64)	X			0.30
Contact Pad Length (X64)	Y			1.50
Contact Pad to Contact Pad (X60)	G	0.20		

**Notes:**

- Dimensioning and tolerancing per ASME Y14.5M  
BSC: Basic Dimension. Theoretically exact value shown without tolerances.
- For best soldering results, thermal vias, if used, should be filled or tented to avoid solder loss during reflow process

**Package Outlines and Dimensions**

**100-Lead Low Profile Quad Flatpack (PL) - 14x14 mm Body [LQFP]**

**Note:** For the most current package drawings, please see the Microchip Packaging Specification located at <http://www.microchip.com/packaging>

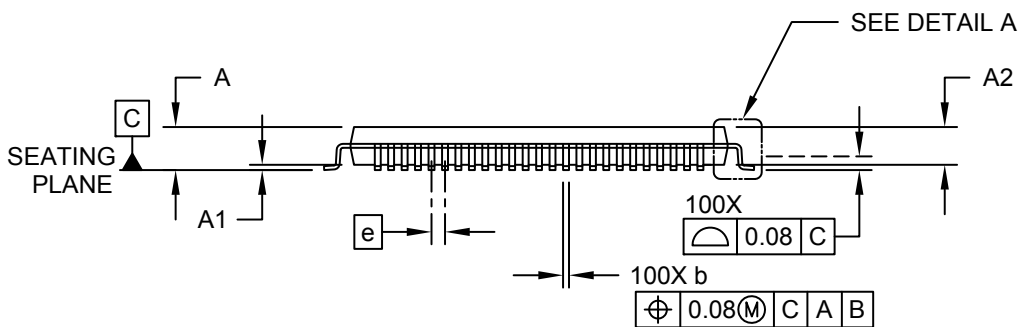
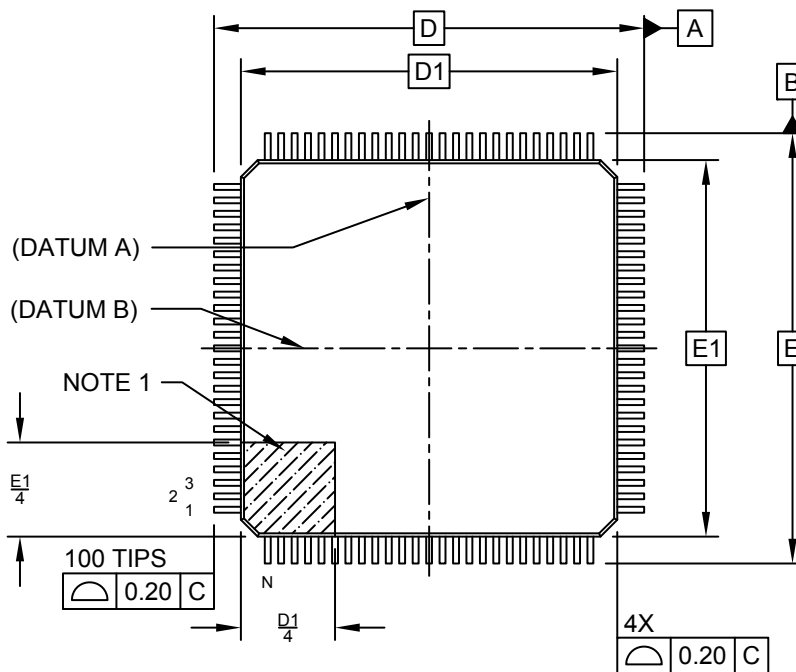



---



---

## Package Outlines and Dimensions

---



---

### 100-Lead Low Profile Quad Flatpack (PL) - 14x14 mm Body [LQFP]

**Note:** For the most current package drawings, please see the Microchip Packaging Specification located at <http://www.microchip.com/packaging>

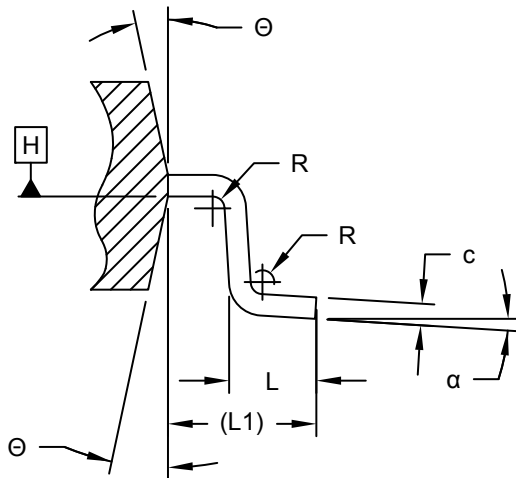

DETAIL A

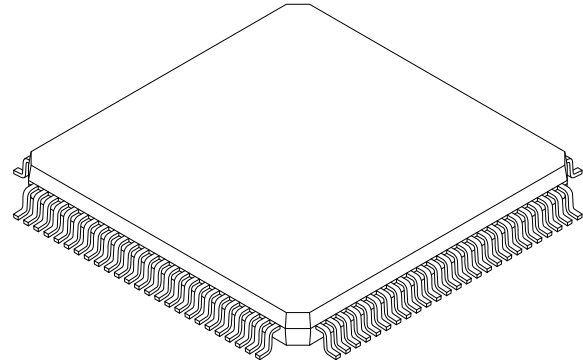

Dimension Limits	Units	MILLIMETERS		
		MIN	NOM	MAX
Number of Leads	N	100		
Pitch	e	0.50 BSC		
Overall Height	A	-	-	1.60
Standoff	A1	0.05	-	0.15
Molded Package Thickness	A2	1.35	-	1.45
Overall Length	D	16.00 BSC		
Molded Package Length	D1	14.00 BSC		
Overall Width	E	16.00 BSC		
Molded Package Width	E1	14.00 BSC		
Lead Width	b	0.17	0.22	0.27
Lead Thickness	c	0.09	-	0.20
Lead Length	L	0.45	0.60	0.75
Footprint	(L1)	1.00 REF		
Mold Draft Angle	$\Theta$	11°	12°	13°
Lead Angle	$\alpha$	0°	3.5°	7°
Bend Radius	R	0.08	-	-

**Notes:**

1. Pin 1 visual index feature may vary, but must be located within the hatched area.
2. Package is saw singulated
3. Dimensioning and tolerancing per ASME Y14.5M

BSC: Basic Dimension. Theoretically exact value shown without tolerances.

REF: Reference Dimension, usually without tolerance, for information purposes only.

**Footprint Outlines and Dimensions**

**100-Lead Low Profile Quad Flatpack (PL) - 14x14 mm Body [LQFP]**

**Note:** For the most current package drawings, please see the Microchip Packaging Specification located at <http://www.microchip.com/packaging>

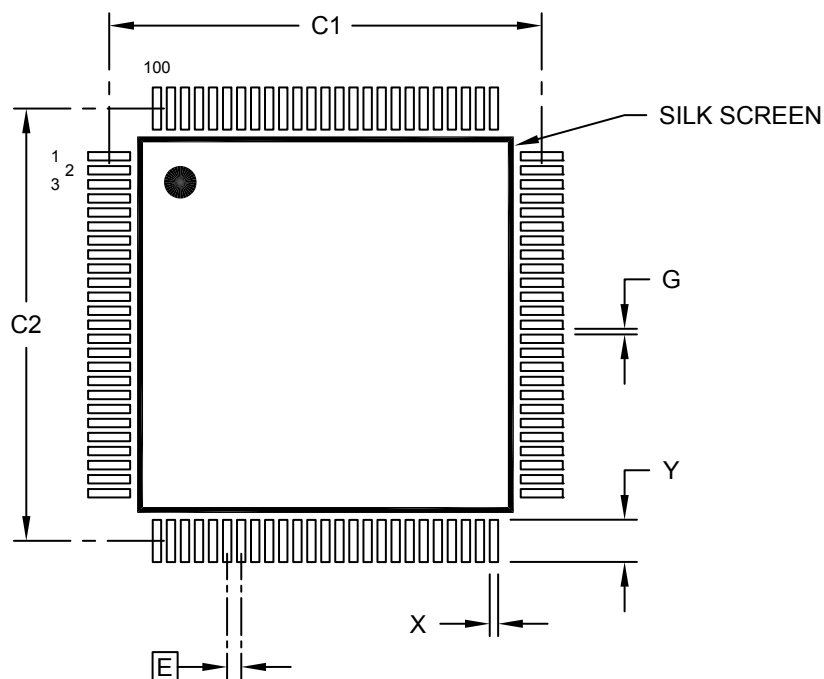

**RECOMMENDED LAND PATTERN**

Dimension Limits	Units	MILLIMETERS		
		MIN	NOM	MAX
Contact Pitch	E	0.50 BSC		
Contact Pad Spacing	C1		15.40	
Contact Pad Spacing	C2		15.40	
Contact Pad Width (X100)	X			0.30
Contact Pad Length (X100)	Y			1.50
Space Between Pads	G	0.20		

**Notes:**

1. Dimensioning and tolerancing per ASME Y14.5M  
BSC: Basic Dimension. Theoretically exact value shown without tolerances.

**Package Outlines and Dimensions**

**128-Lead Low Profile Plastic Quad Flat Pack (PT) – 14x14x1.4 mm Body [LQFP]**

**Note:** For the most current package drawings, please see the Microchip Packaging Specification located at <http://www.microchip.com/packaging>

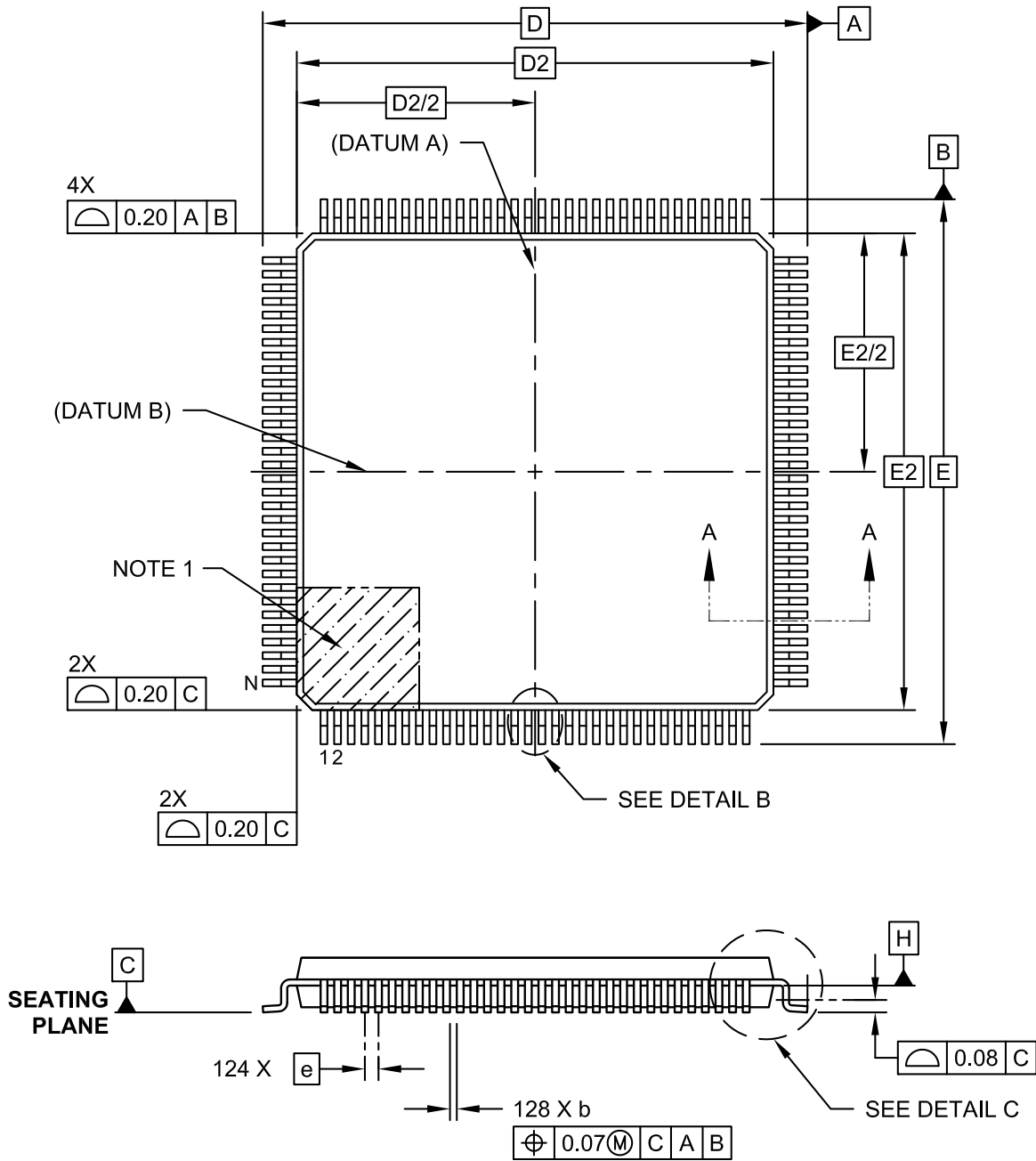

## Package Outlines and Dimensions

### 128-Lead Low Profile Plastic Quad Flat Pack (PT) – 14x14x1.4 mm Body [LQFP]

**Note:** For the most current package drawings, please see the Microchip Packaging Specification located at <http://www.microchip.com/packaging>

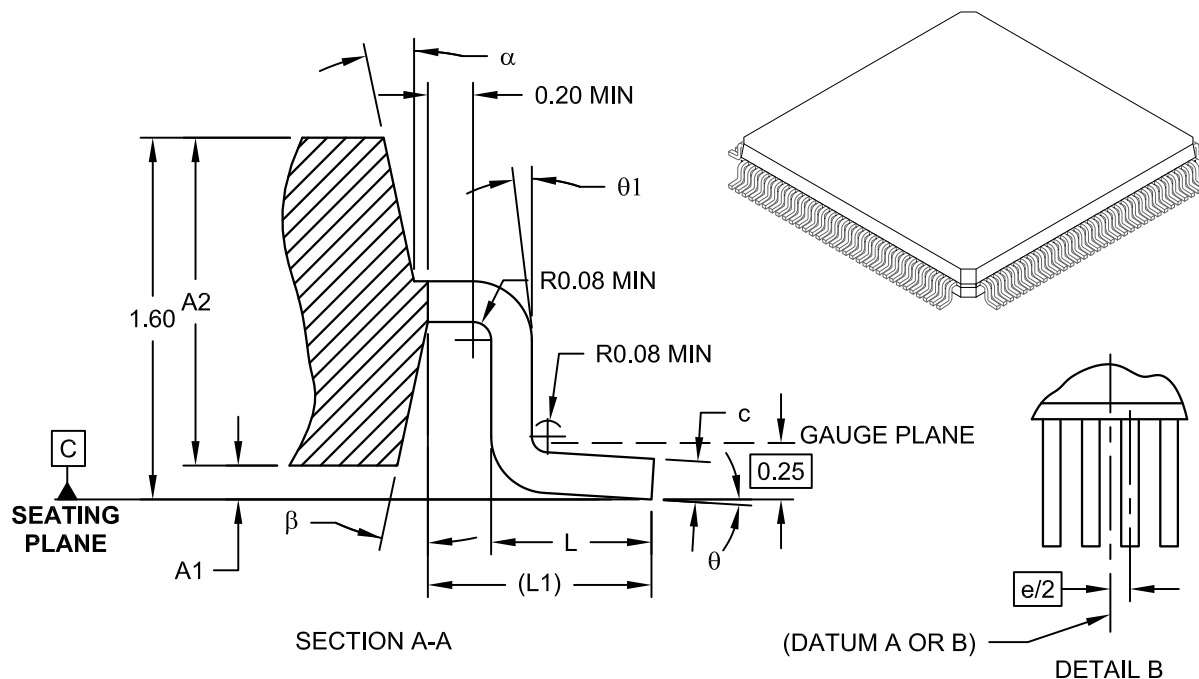

Dimension	Units	MILLIMETERS		
		Limits	MIN	NOM
Number of Pins	N		128	
Pitch	e		0.40 BSC	
Overall Height	A	-	-	1.60
Molded Package Thickness	A2	1.35	1.40	1.45
Standoff	A1	0.05	-	0.15
Foot Length	L	0.45	0.60	0.75
Footprint	L1		1.00 REF	
Lead Angle	$\theta$	0°	-	-
Foot Angle	$\theta_1$	0°	3.5°	7°
Overall Width	D		16.00 BSC	
Overall Length	E		16.00 BSC	
Molded Body Width	D1		14.00 BSC	
Molded Body Length	E1		14.00 BSC	
Lead Thickness	c	0.09	-	0.20
Foot Angle	$\theta$	0°	-	-
Mold Draft Angle Top	$\alpha$	-	-	-
Mold Draft Angle Bottom	$\beta$	-	-	-

**Notes:**

- Pin 1 visual index feature may vary, but must be located within the hatched area.
- Exact shape at each corner may vary.
- Dimensioning and tolerancing per ASME Y14.5M.  
 BSC: Basic Dimension. Theoretically exact value shown without tolerances.  
 REF: Reference Dimension, usually without tolerance, for information purposes only.

**Package Outlines and Dimensions**

**144-Lead Plastic Low Profile Quad Flatpack (PL) – 20x20x1.40 mm Body, with 2.00 mm Footprint [LQFP]**

**Note:** For the most current package drawings, please see the Microchip Packaging Specification located at <http://www.microchip.com/packaging>

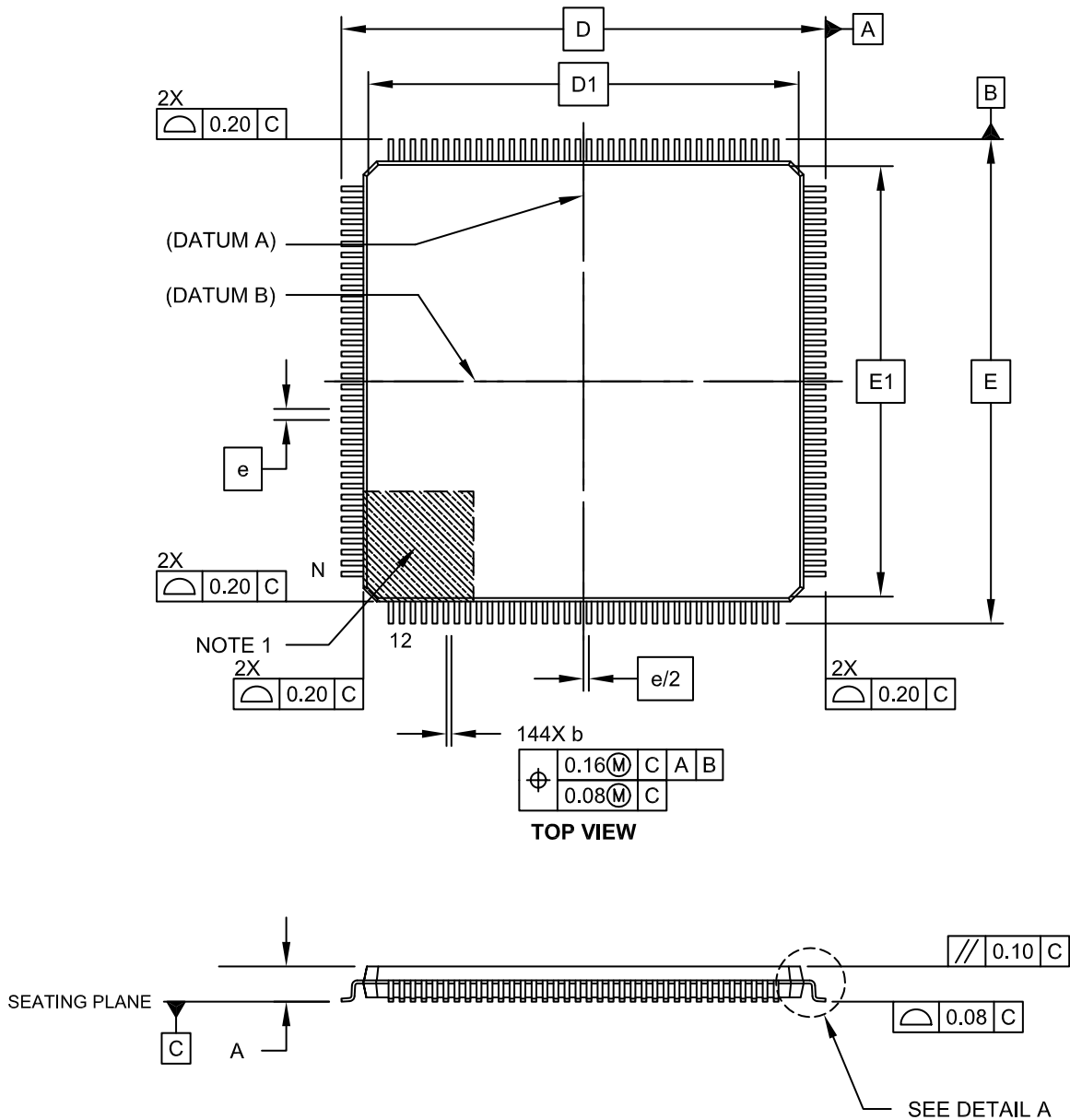

**Package Outlines and Dimensions**

**144-Lead Plastic Low Profile Quad Flatpack (PL) – 20x20x1.40 mm Body, with 2.00 mm Footprint [LQFP]**

**Note:** For the most current package drawings, please see the Microchip Packaging Specification located at <http://www.microchip.com/packaging>

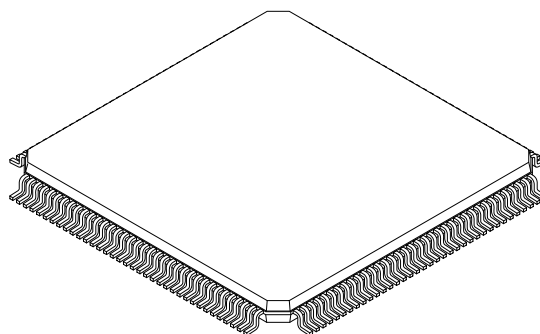
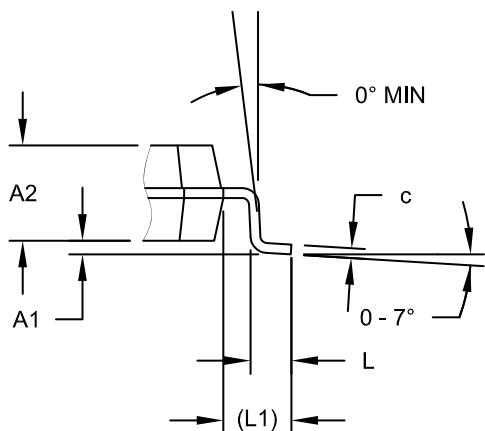

**DETAIL A**

Dimension Limits	Units	MILLIMETERS		
		MIN	NOM	MAX
Number of Leads	N		144	
Lead Pitch	e		0.50 BSC	
Overall Height	A	-	-	1.60
Molded Package Height	A2	1.35	1.40	1.45
Standoff	A1	0.05	-	0.15
Foot Length	L	0.45	0.60	0.75
Footprint	L1	1.00 (REF)		
Overall Width	E	22.00 BSC		
Overall Length	D	22.00 BSC		
Molded Body Width	E1	20.00 BSC		
Molded Body Length	D1	20.00 BSC		
Lead Thickness	c	0.09	-	0.20
Lead Width	b	0.17	0.22	0.27

**Notes:**

1. Pin 1 visual index feature may vary, but must be located within the hatched area.
2. Package is saw singulated.
3. Dimensioning and tolerancing per ASME Y14.5M.

BSC: Basic Dimension. Theoretically exact value shown without tolerances.

REF: Reference Dimension, usually without tolerance, for information purposes only.

## Footprint Outlines and Dimensions

144-Lead Plastic Low Profile Quad Flatpack (PL) - 20x20x1.40 mm Body [LQFP]  
 2.00 mm Footprint

**Note:** For the most current package drawings, please see the Microchip Packaging Specification located at <http://www.microchip.com/packaging>

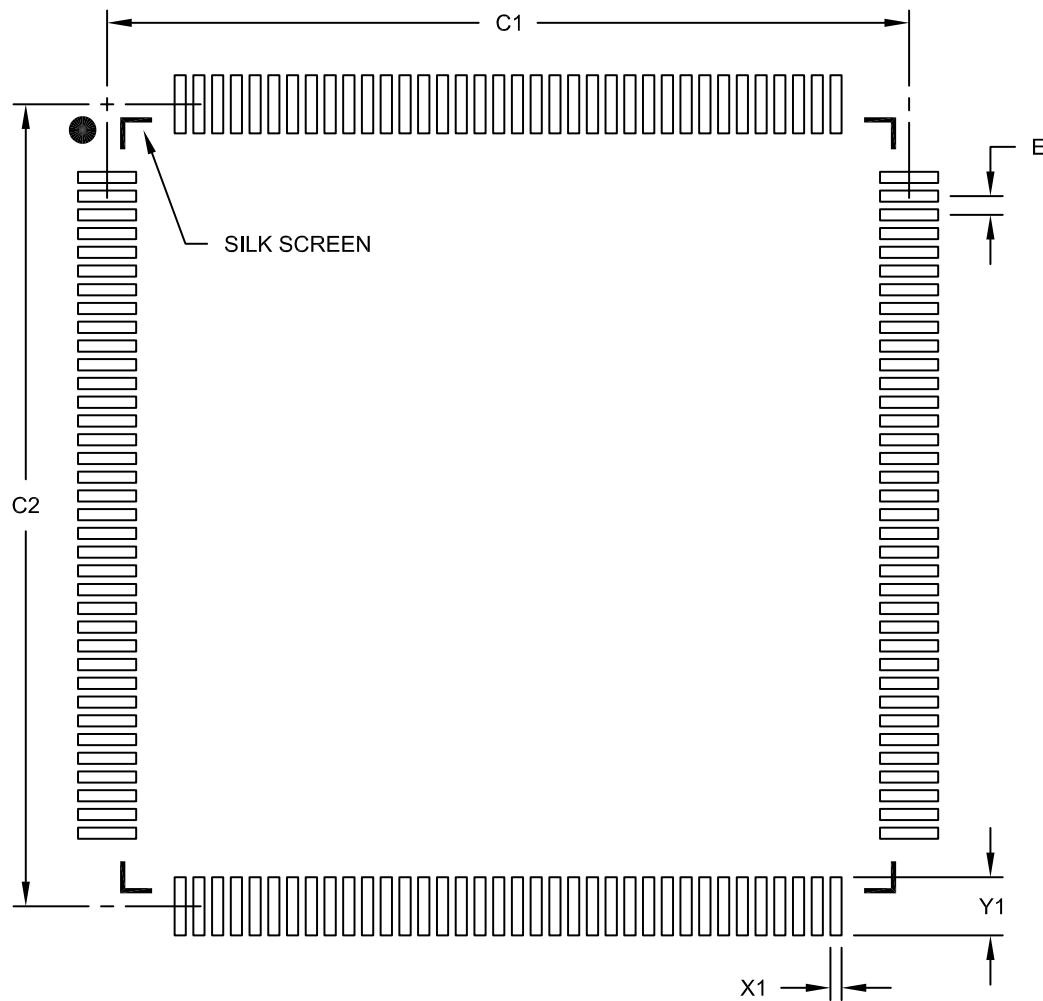

### RECOMMENDED LAND PATTERN

	Units	MILLIMETERS		
		Dimension Limits		
		MIN	NOM	MAX
Contact Pitch	E	0.50 BSC		
Contact Pad Spacing	C1		21.40	
Contact Pad Spacing	C2		21.40	
Contact Pad Width (X144)	X1			0.30
Contact Pad Length (X144)	Y1			1.55

**Notes:**

1. Dimensioning and tolerancing per ASME Y14.5M

BSC: Basic Dimension. Theoretically exact value shown without tolerances.

Microchip Technology Drawing No. C04-2044B

**Package Outlines and Dimensions**

**160-Lead Low Profile Quad Flatpack (6G) - 24x24 mm Body [LQFP]  
With 2.00 mm Footprint**

**Note:** For the most current package drawings, please see the Microchip Packaging Specification located at <http://www.microchip.com/packaging>

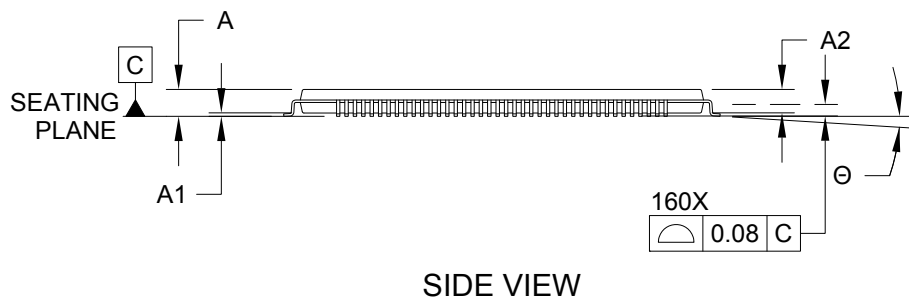
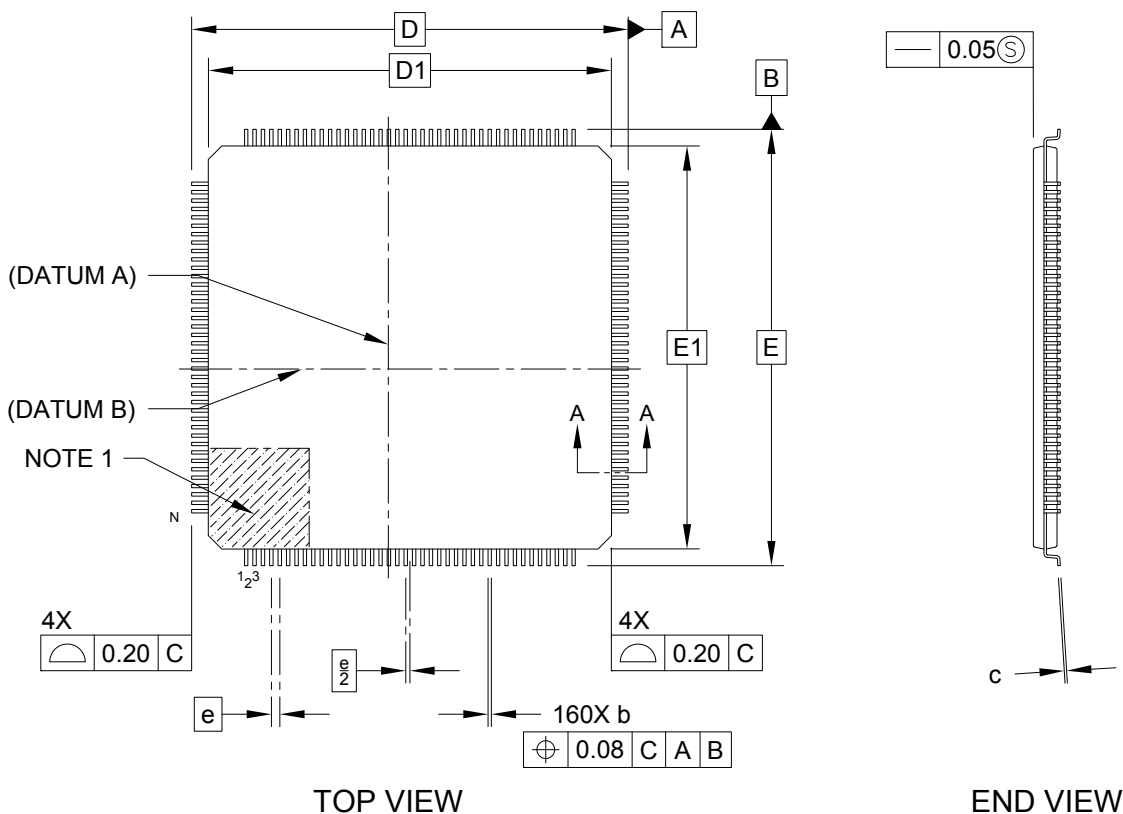



---



---

## Package Outlines and Dimensions

---



---

### 160-Lead Low Profile Quad Flatpack (6G) - 24x24 mm Body [LQFP] With 2.00 mm Footprint

**Note:** For the most current package drawings, please see the Microchip Packaging Specification located at <http://www.microchip.com/packaging>

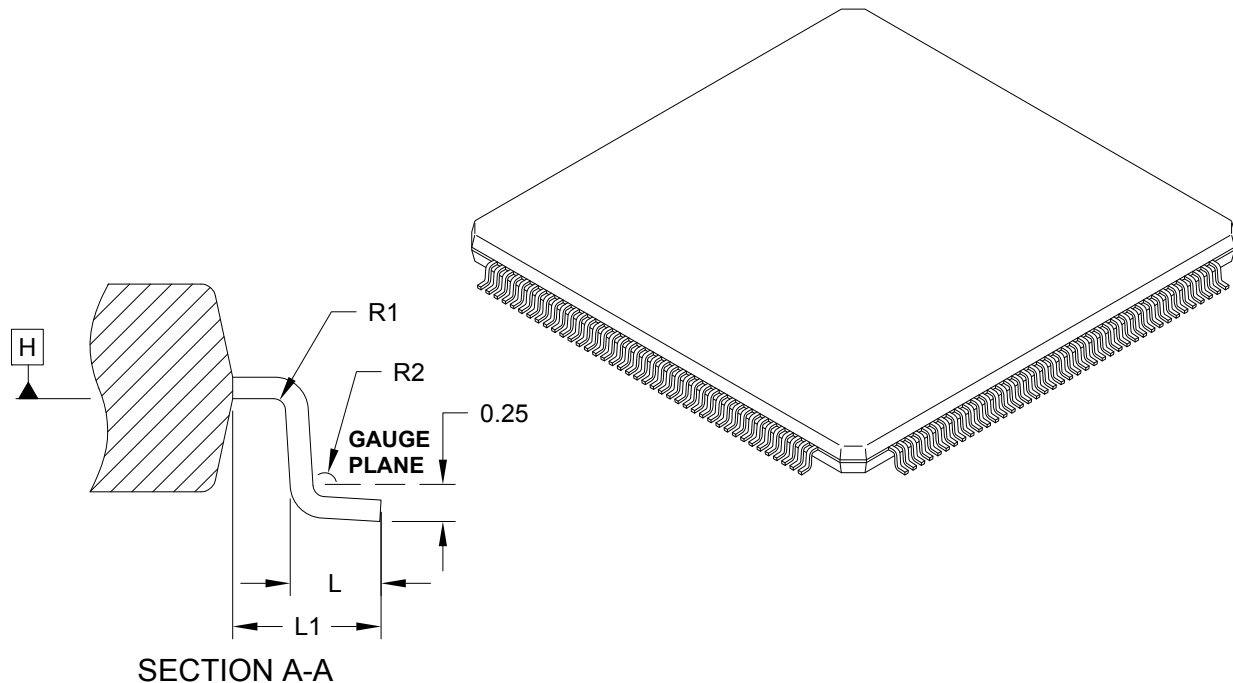

Dimension Limits	Units	MILLIMETERS		
		MIN	NOM	MAX
Number of Terminals	N	160		
Pitch	e	0.50 BSC		
Overall Height	A	-	-	1.60
Standoff	A1	0.05	0.10	0.15
Molded Package Thickness	A2	1.35	1.40	1.45
Overall Length	D	26.00 BSC		
Molded Package Length	D1	24.00 BSC		
Overall Width	E	26.00 BSC		
Molded Package Width	E1	24.00 BSC		
Terminal Width	b	0.17	0.20	0.27
Terminal Thickness	c	0.09	-	0.20
Terminal Length	L	0.45	0.60	0.75
Footprint	L1	1.00 REF		
Lead Bend Radius	R1	0.08	-	-
Lead Bend Radius	R2	0.08	-	0.20
Foot Angle	Θ	0°	3.5°	7°

**Notes:**

1. Pin 1 visual index feature may vary, but must be located within the hatched area.
2. Dimensioning and tolerancing per ASME Y14.5M

BSC: Basic Dimension. Theoretically exact value shown without tolerances.

REF: Reference Dimension, usually without tolerance, for information purposes only.

**Footprint Outlines and Dimensions**

**160-Lead Low Profile Quad Flatpack (6G) - 24x24 mm Body [LQFP]  
With 2.00 mm Footprint**

**Note:** For the most current package drawings, please see the Microchip Packaging Specification located at <http://www.microchip.com/packaging>

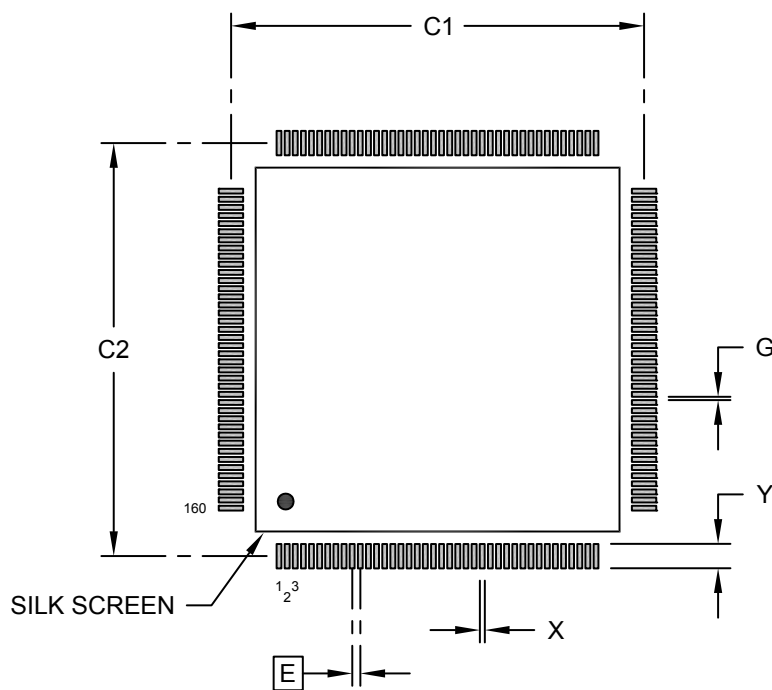

**RECOMMENDED LAND PATTERN**

Dimension Limits	Units	MILLIMETERS		
		MIN	NOM	MAX
Contact Pitch	E	0.50 BSC		
Contact Pad Spacing	C1		25.40	
Contact Pad Spacing	C2		25.40	
Contact Pad Width (X20)	X			0.30
Contact Pad Length (X20)	Y			1.50
Contact Pad to Contact Pad (X154)	G	0.20		

**Notes:**

1. Dimensioning and tolerancing per ASME Y14.5M  
BSC: Basic Dimension. Theoretically exact value shown without tolerances.

**Package Outlines and Dimensions**

**176-Lead Low Profile Quad Flat Pack (2J) - 20x20x1.4 mm Body [LQFP]  
With 7x7 mm Exposed Pad**

**Note:** For the most current package drawings, please see the Microchip Packaging Specification located at <http://www.microchip.com/packaging>

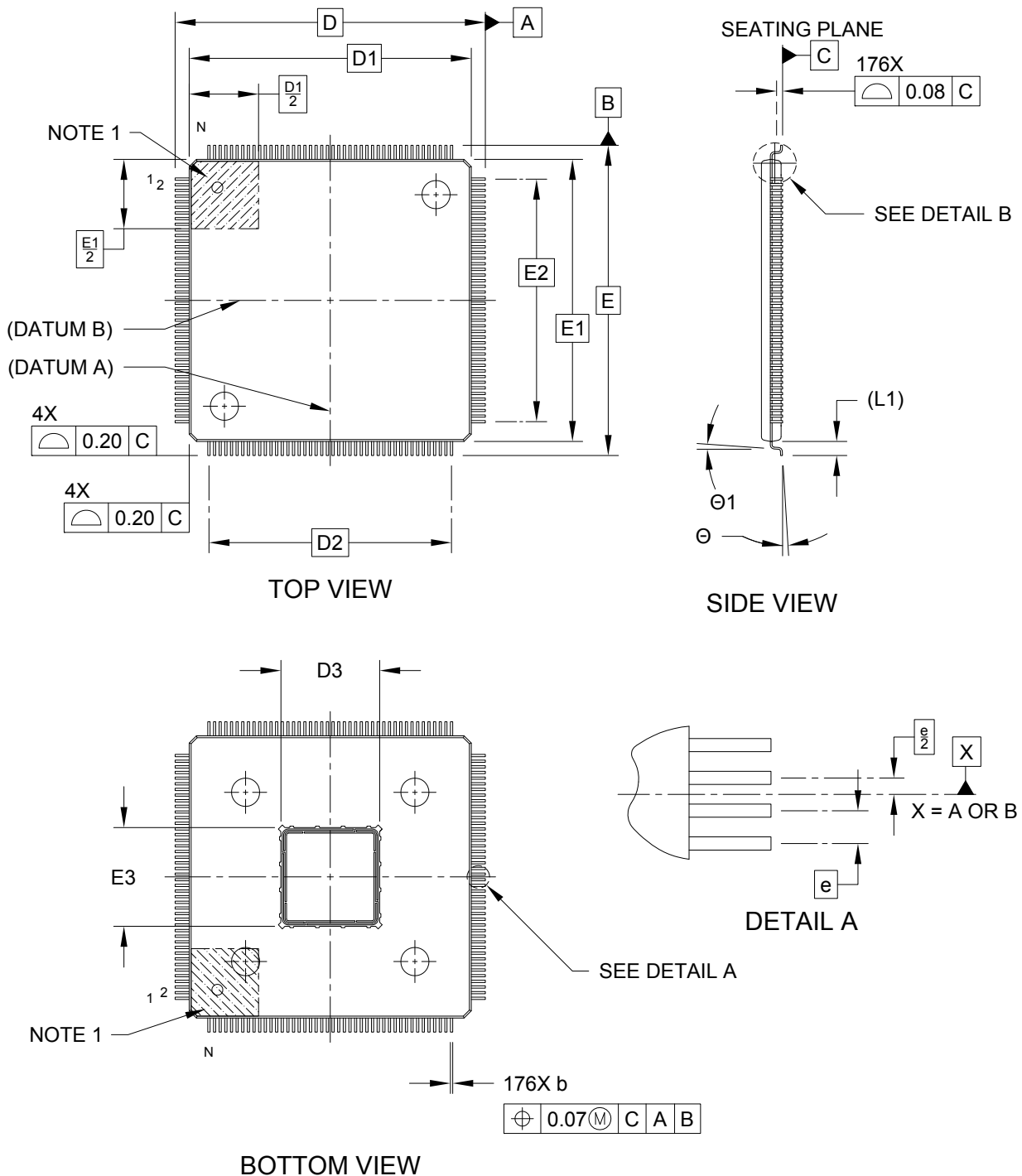

**Package Outlines and Dimensions**

**176-Lead Low Profile Quad Flat Pack (2J) - 20x20x1.4 mm Body [LQFP]  
With 7x7 mm Exposed Pad**

**Note:** For the most current package drawings, please see the Microchip Packaging Specification located at <http://www.microchip.com/packaging>

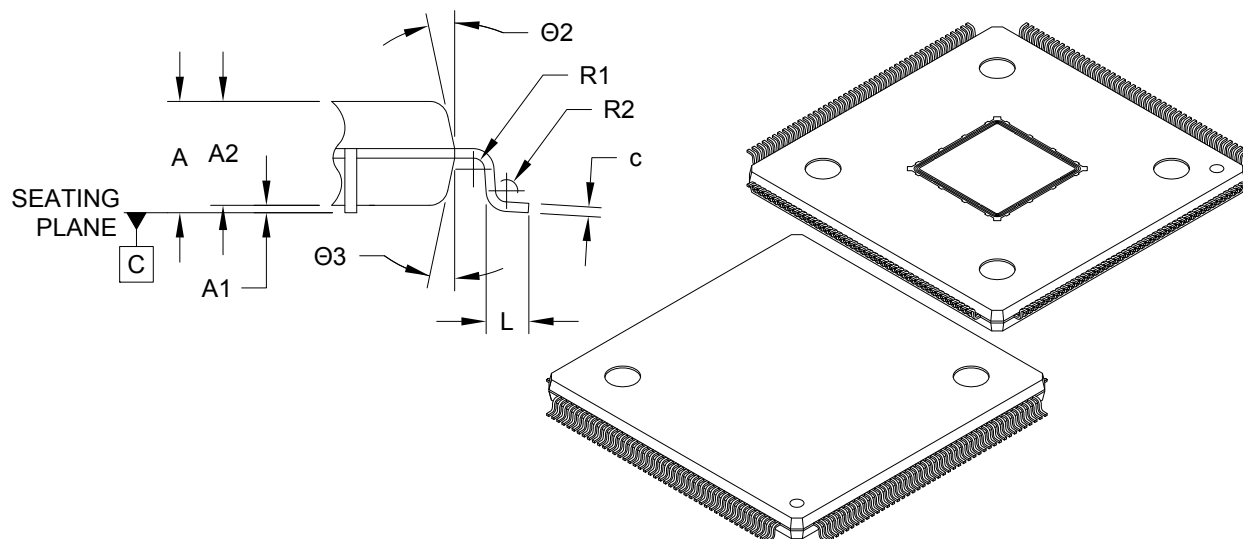

Units		MILLIMETERS		
Dimension Limits		MIN	NOM	MAX
Number of Leads	N	176		
Pitch	e	0.40 BSC		
Overall Height	A	-	-	1.60
Standoff	A1	0.05	-	0.15
Molded Package Height	A2	1.35	1.40	1.45
Overall Length	D	22.00 BSC		
Molded Package Length	D1	20.00 BSC		
Overall Lead Pitch	D2	17.20 BSC		
Exposed Pad Length	D3	6.90	7.00	7.10
Overall Width	E	22.00 BSC		
Molded Package Width	E1	20.00 BSC		
Overall Lead Pitch	E2	17.20 BSC		
Exposed Pad Width	E3	6.90	7.00	7.10

Units		MILLIMETERS		
Dimension Limits		MIN	NOM	MAX
Lead Width	b	0.13	0.16	0.23
Lead Thickness	c	0.09	-	0.20
Lead Length	L	0.45	0.60	0.75
Footprint	(L1)	1.00 REF		
Bend Radius	R1	0.08	-	-
Bend Radius	R2	0.08	-	0.20
Foot Angle	Θ	0°	3.5°	7°
Lead Angle	Θ1	0°	-	-
Mold Draft Angle	Θ2	11°	12°	13°
Mold Draft Angle	Θ3	11°	12°	13°

**Notes:**

- Pin 1 visual index feature may vary, but must be located within the hatched area.
- Dimensions D1 and E1 do not include mold protrusion. Allowable Protrusion is 0.25mm per side. D1 and E1 are maximum body size dimensions including mold mismatch.
- Dimension b does not include dambar protrusion. Allowable dam bar protrusion shall not cause the lead width to exceed the maximum b dimension by more than 0.08mm  
Dambar cannot be located on the lower radius or the foot. Minimum space between protrusion and adjacent lead is 0.07mm for 0.40mm pitch packages.
- Dimensioning and tolerancing per ASME Y14.5M  
BSC: Basic Dimension. Theoretically exact value shown without tolerances.  
REF: Reference Dimension, usually without tolerance, for information purposes only.

---



---

## Footprint Outlines and Dimensions

---



---

### 176-Lead Low Profile Quad Flat Pack (2J) - 20x20x1.4 mm Body [LQFP] With 7x7 mm Exposed Pad

**Note:** For the most current package drawings, please see the Microchip Packaging Specification located at <http://www.microchip.com/packaging>

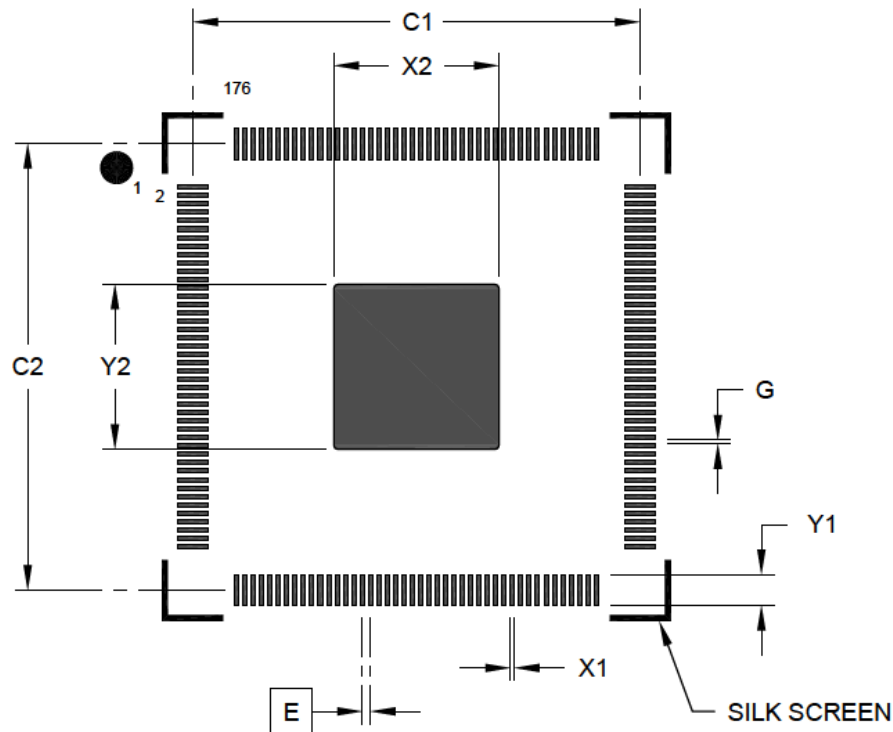

**RECOMMENDED LAND PATTERN**

Dimension Limits	Units	MILLIMETERS		
		MIN	NOM	MAX
Contact Pitch	E	0.40 BSC		
Contact Pad Spacing	C1		21.40	
Contact Pad Spacing	C2		21.40	
Contact Pad Width (X176)	X1			0.20
Contact Pad Length (X176)	Y1			1.50
Center Pad Width	X2			7.90
Center Pad Length	Y2			7.90
Contact Pad to Pad (X172)	G	0.20		

**Notes:**

1. Dimensioning and tolerancing per ASME Y14.5M

BSC: Basic Dimension. Theoretically exact value shown without tolerances.



**MICROCHIP**

---

---

**Package Outlines and Dimensions**

---

---

NOTES:

---

---

**Package Outlines and Dimensions**

---

---

**MQFP**

**Package Outlines and Dimensions**

**44-Lead Plastic Metric Quad Flatpack (KW) – 10x10x2 mm Body, 3.20 mm [MQFP]**

**Note:** For the most current package drawings, please see the Microchip Packaging Specification located at <http://www.microchip.com/packaging>

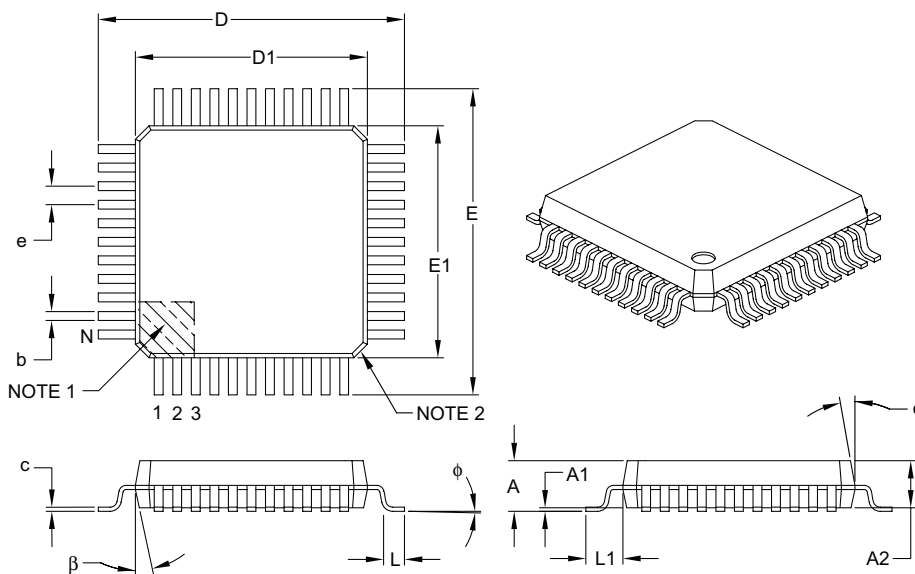

Dimension Limits	Units	MILLIMETERS		
		MIN	NOM	MAX
Number of Leads	N	44		
Lead Pitch	e	0.80 BSC		
Overall Height	A	–	–	2.45
Molded Package Thickness	A2	1.80	2.00	2.20
Standoff §	A1	0.00	–	0.25
Foot Length	L	0.73	0.88	1.03
Footprint	L1	1.60 REF		
Foot Angle	φ	0°	–	7°
Overall Width	E	13.20 BSC		
Overall Length	D	13.20 BSC		
Molded Package Width	E1	10.00 BSC		
Molded Package Length	D1	10.00 BSC		
Lead Thickness	c	0.11	–	0.23
Lead Width	b	0.29	–	0.45
Mold Draft Angle Top	α	5°	–	16°
Mold Draft Angle Bottom	β	5°	–	16°

**Notes:**

- Pin 1 visual index feature may vary, but must be located within the hatched area.
- Chamfers at corners are optional; size may vary.
- Dimensions D1 and E1 do not include mold flash or protrusions. Mold flash or protrusions shall not exceed 0.25 mm per side.
- Dimensioning and tolerancing per ASME Y14.5M.

BSC: Basic Dimension. Theoretically exact value shown without tolerances.

REF: Reference Dimension, usually without tolerance, for information purposes only.

- § Significant Characteristic.



---



---

## Footprint Outlines and Dimensions

---



---

44-Lead Plastic Metric Quad Flatpack (KW) - 10x10x2 mm Body, 3.20 mm Footprint [MQFP]

**Note:** For the most current package drawings, please see the Microchip Packaging Specification located at <http://www.microchip.com/packaging>

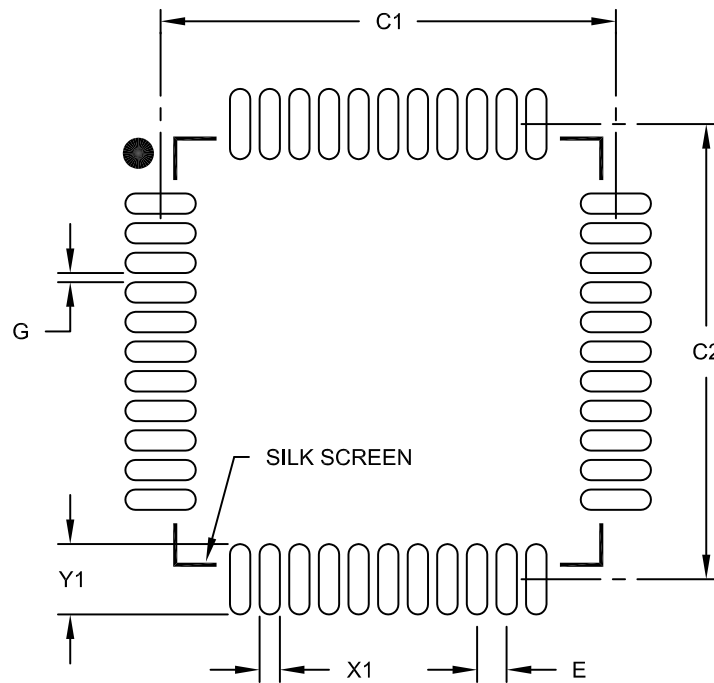

**RECOMMENDED LAND PATTERN**

Dimension Limits	Units	MILLIMETERS		
		MIN	NOM	MAX
Contact Pitch	E	0.80 BSC		
Contact Pad Spacing	C1		12.30	
Contact Pad Spacing	C2		12.30	
Contact Pad Width (X44)	X1			0.55
Contact Pad Length (X44)	Y1			1.90
Distance Between Pads	G	0.25		

**Notes:**

1. Dimensioning and tolerancing per ASME Y14.5M

BSC: Basic Dimension. Theoretically exact value shown without tolerances.

Microchip Technology Drawing No. C04-2071B

**Package Outlines and Dimensions**

**44-Lead Plastic Metric Quad Flatpack (PQ) – 10x10x2 mm Body, 3.20 mm [MQFP]**

**Note:** For the most current package drawings, please see the Microchip Packaging Specification located at <http://www.microchip.com/packaging>

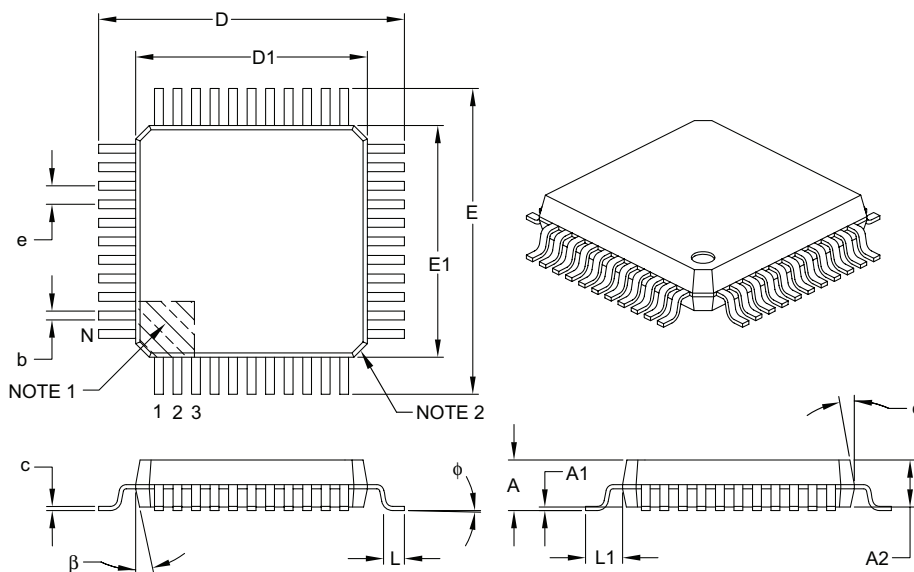

Dimension Limits	Units	MILLIMETERS		
		MIN	NOM	MAX
Number of Leads	N	44		
Lead Pitch	e	0.80 BSC		
Overall Height	A	–	–	2.45
Molded Package Thickness	A2	1.80	2.00	2.20
Standoff §	A1	0.00	–	0.25
Foot Length	L	0.73	0.88	1.03
Footprint	L1	1.60 REF		
Foot Angle	φ	0°	–	7°
Overall Width	E	13.20 BSC		
Overall Length	D	13.20 BSC		
Molded Package Width	E1	10.00 BSC		
Molded Package Length	D1	10.00 BSC		
Lead Thickness	c	0.11	–	0.23
Lead Width	b	0.29	–	0.45
Mold Draft Angle Top	α	5°	–	16°
Mold Draft Angle Bottom	β	5°	–	16°

**Notes:**

1. Pin 1 visual index feature may vary, but must be located within the hatched area.
2. Chamfers at corners are optional; size may vary.
3. Dimensions D1 and E1 do not include mold flash or protrusions. Mold flash or protrusions shall not exceed 0.25 mm per side.
4. Dimensioning and tolerancing per ASME Y14.5M.
  - BSC: Basic Dimension. Theoretically exact value shown without tolerances.
  - REF: Reference Dimension, usually without tolerance, for information purposes only.
5. § Significant Characteristic.

---



---

## Footprint Outlines and Dimensions

---



---

### 44-Lead Plastic Metric Quad Flatpack (PQ) - 10x10x2 mm Body, 3.20 mm Footprint [MQFP]

**Note:** For the most current package drawings, please see the Microchip Packaging Specification located at <http://www.microchip.com/packaging>

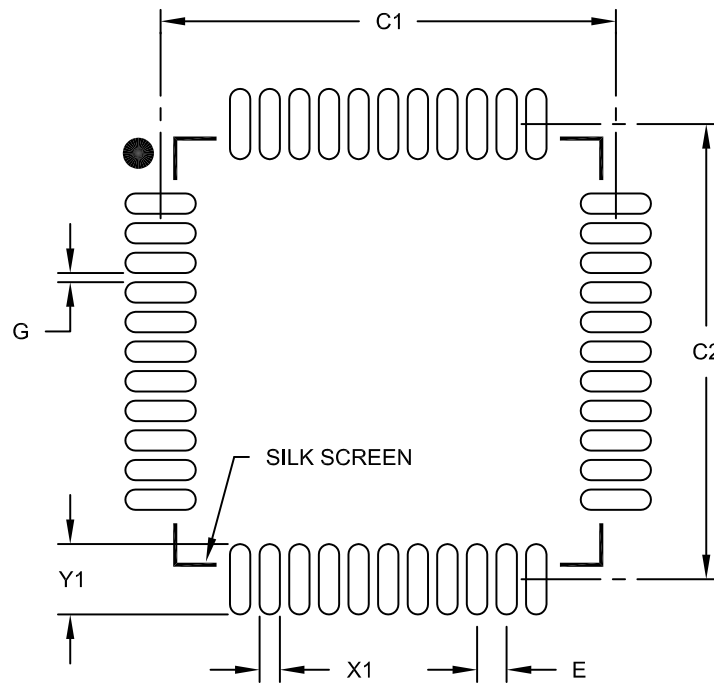

**RECOMMENDED LAND PATTERN**

Dimension Limits	Units	MILLIMETERS		
		MIN	NOM	MAX
Contact Pitch	E	0.80 BSC		
Contact Pad Spacing	C1		12.30	
Contact Pad Spacing	C2		12.30	
Contact Pad Width (X44)	X1			0.55
Contact Pad Length (X44)	Y1			1.90
Distance Between Pads	G	0.25		

**Notes:**

1. Dimensioning and tolerancing per ASME Y14.5M

BSC: Basic Dimension. Theoretically exact value shown without tolerances.

Microchip Technology Drawing No. C04-2071B

**Package Outlines and Dimensions**

**64-Lead Plastic Metric Quad Flatpack (BU) – 14x14x2.7 mm Body, 3.20 mm [MQFP]**

**Note:** For the most current package drawings, please see the Microchip Packaging Specification located at <http://www.microchip.com/packaging>

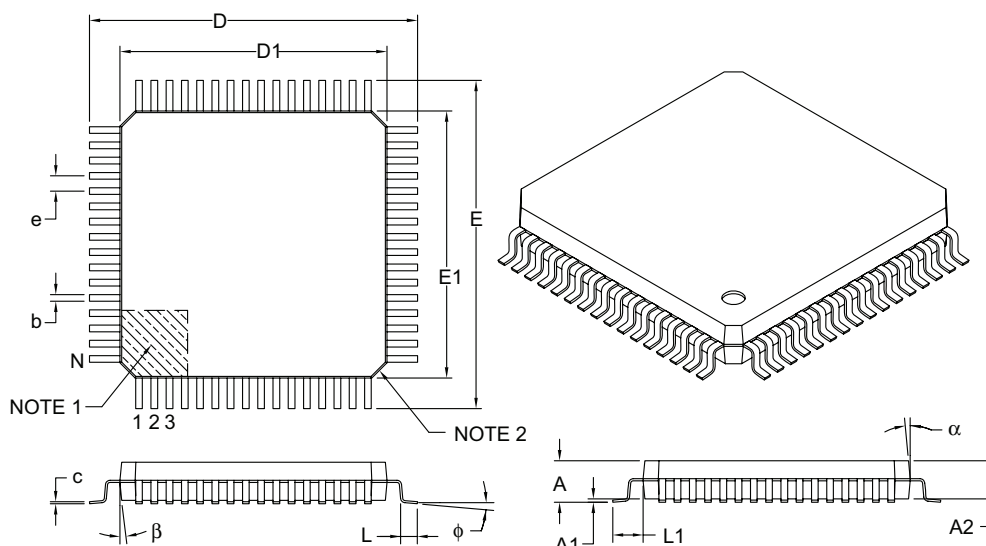

Dimension Limits	Units	MILLIMETERS		
		MIN	NOM	MAX
Number of Leads	N	64		
Lead Pitch	e	0.80 BSC		
Overall Height	A	–	–	3.15
Molded Package Thickness	A2	2.50	2.70	2.90
Standoff §	A1	0.00	–	0.25
Overall Width	E	17.20 BSC		
Molded Package Width	E1	14.00 BSC		
Overall Length	D	17.20 BSC		
Molded Package Length	D1	14.00 BSC		
Foot Length	L	0.73	0.88	1.03
Footprint	L1	1.60 REF		
Foot Angle	φ	0°	–	7°
Lead Thickness	c	0.11	–	0.23
Lead Width	b	0.29	–	0.45
Mold Draft Angle Top	α	5°	–	16°
Mold Draft Angle Bottom	β	5°	–	16°

**Notes:**

- Pin 1 visual index feature may vary, but must be located within the hatched area.
- Chamfers at corners are optional; size may vary.
- Dimensions D1 and E1 do not include mold flash or protrusions. Mold flash or protrusions shall not exceed 0.25 mm per side.
- Dimensioning and tolerancing per ASME Y14.5M.
  - BSC: Basic Dimension. Theoretically exact value shown without tolerances.
  - REF: Reference Dimension, usually without tolerance, for information purposes only.
- § Significant Characteristic.
- Formerly TelCom PQFP package.

---



---

## Footprint Outlines and Dimensions

---



---

64-Lead Plastic Metric Quad FlatPack (BU) - 14x14x2.7 mm Body 3.20 mm Footprint [MQFP]

**Note:** For the most current package drawings, please see the Microchip Packaging Specification located at <http://www.microchip.com/packaging>

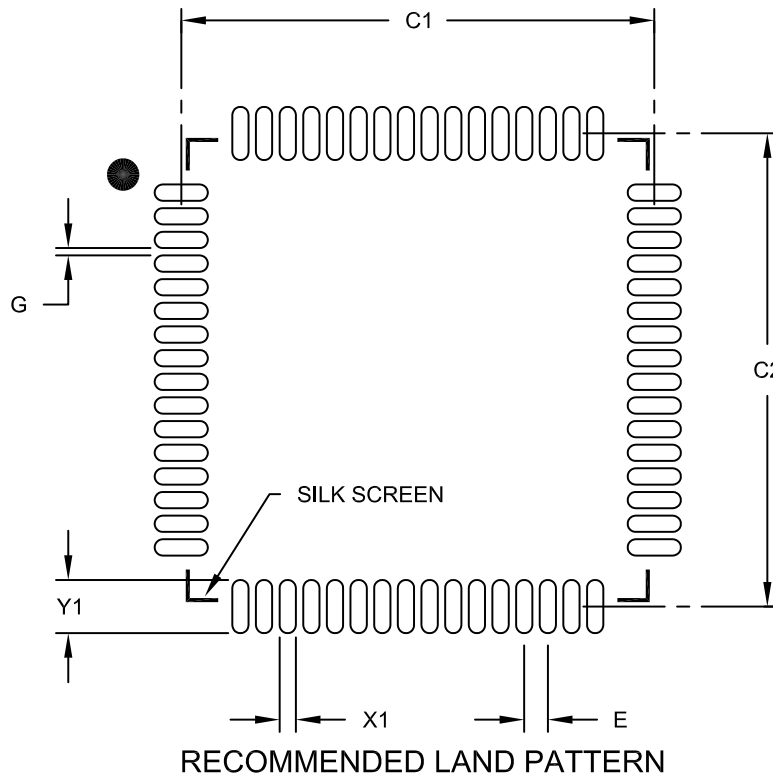

Dimension Limits	Units	MILLIMETERS		
		MIN	NOM	MAX
Contact Pitch	E	0.80 BSC		
Contact Pad Spacing	C1		16.10	
Contact Pad Spacing	C2		16.10	
Contact Pad Width (X64)	X1			0.55
Contact Pad Length (X64)	Y1			1.80
Distance Between Pads	G	0.25		

**Notes:**

1. Dimensioning and tolerancing per ASME Y14.5M

BSC: Basic Dimension. Theoretically exact value shown without tolerances.

Microchip Technology Drawing No. C04-2022B

**Package Outlines and Dimensions**

**100-Lead Plastic Metric Quad Flatpack (PQ) - 14x20 mm Body [MQFP]  
3.90 mm Footprint**

**Note:** For the most current package drawings, please see the Microchip Packaging Specification located at <http://www.microchip.com/packaging>

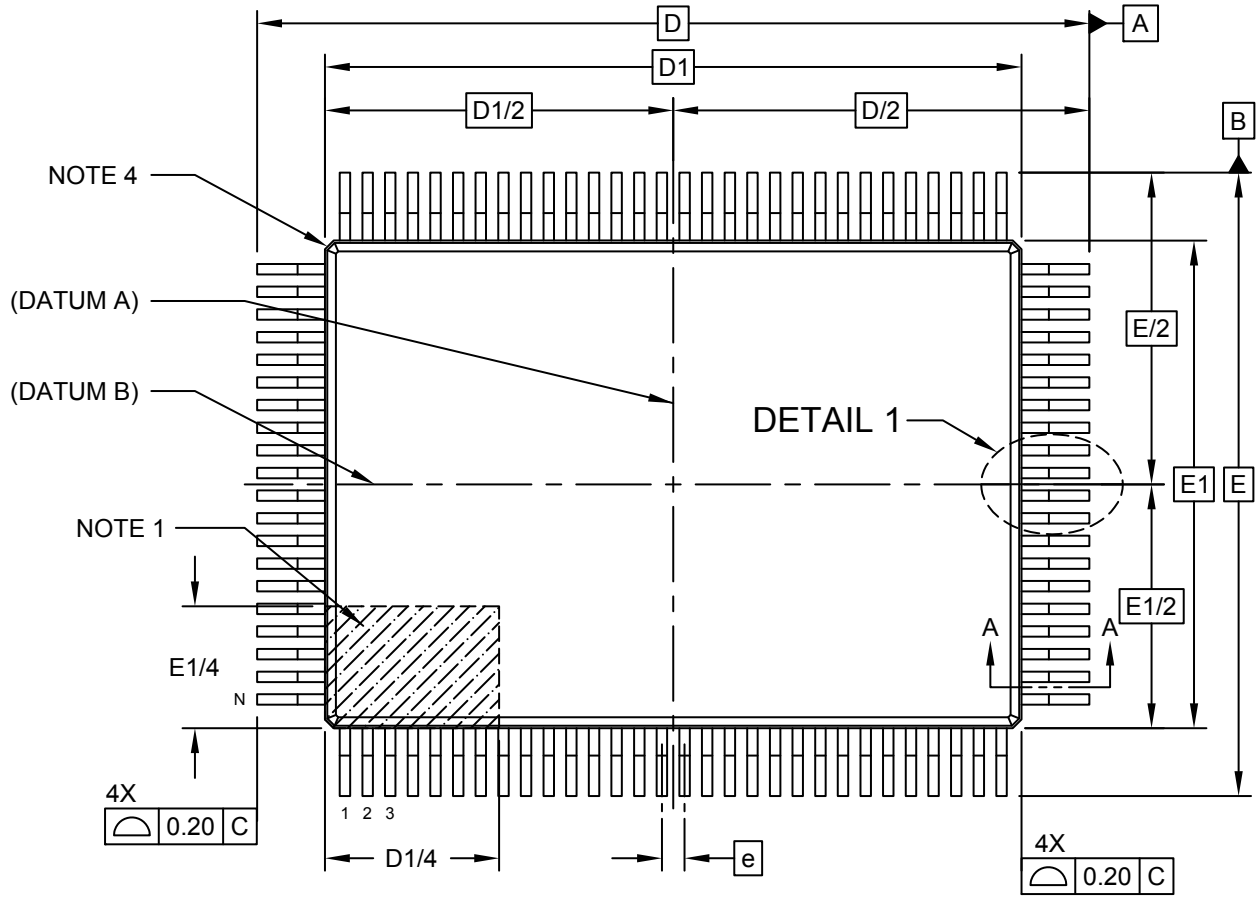

TOP VIEW

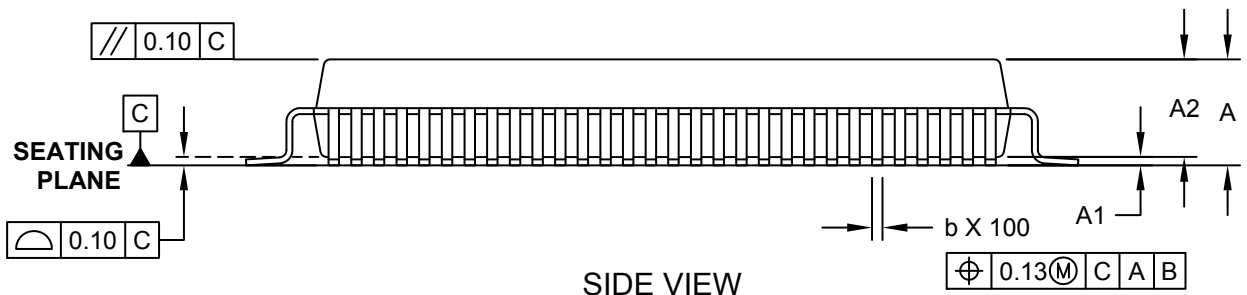

SIDE VIEW

---



---

## Package Outlines and Dimensions

---



---

### 100-Lead Plastic Metric Quad Flatpack (PQ) - 14x20 mm Body [MQFP] 3.90 mm Footprint

**Note:** For the most current package drawings, please see the Microchip Packaging Specification located at <http://www.microchip.com/packaging>

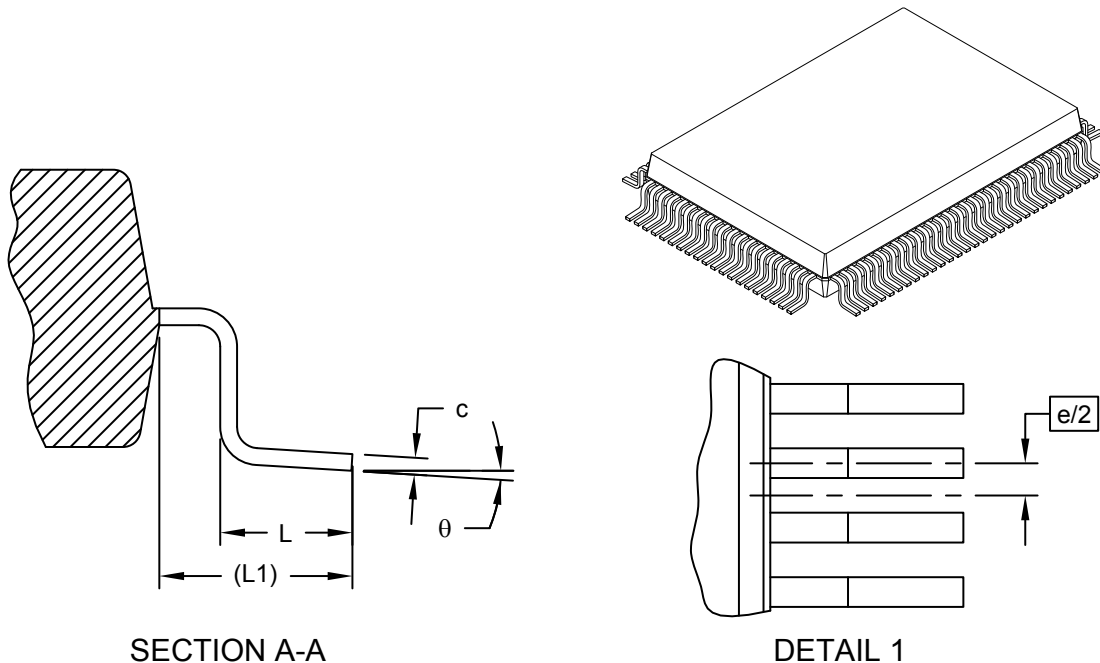

Dimension	Units	MILLIMETERS		
		MIN	NOM	MAX
Number of Pins	N	100		
Pitch	e	0.65 BSC		
Overall Height	A	-	-	3.40
Standoff	A1	0.25	-	-
Molded Package Thickness	A2	2.50	2.70	2.90
Overall Length	D	23.20 BSC		
Molded Package Length	D1	20.00 BSC		
Overall Width	E	17.20 BSC		
Molded Package Width	E1	14.00 BSC		
Terminal Width	b	0.22	-	0.40
Terminal Thickness	c	0.11	-	0.23
Terminal Length	L	0.73	0.88	1.03
Footprint	(L1)	1.95 REF		
Foot Angle	$\theta$	0°	3.5°	7°

**Notes:**

1. Pin 1 visual index feature may vary, but must be located within the hatched area.
2. Exact shape of each corner is optional.
3. Dimensioning and tolerancing per ASME Y14.5M  
     BSC: Basic Dimension. Theoretically exact value shown without tolerances.  
     REF: Reference Dimension, usually without tolerance, for information purposes only.
4. Exact shape of each corner is optional.

**Package Outlines and Dimensions**

**256-Lead Plastic Metric Quad Flatpack (PQ) - 28x28x3.40 mm Body [MQFP]  
2.60 mm Footprint**

**Note:** For the most current package drawings, please see the Microchip Packaging Specification located at <http://www.microchip.com/packaging>

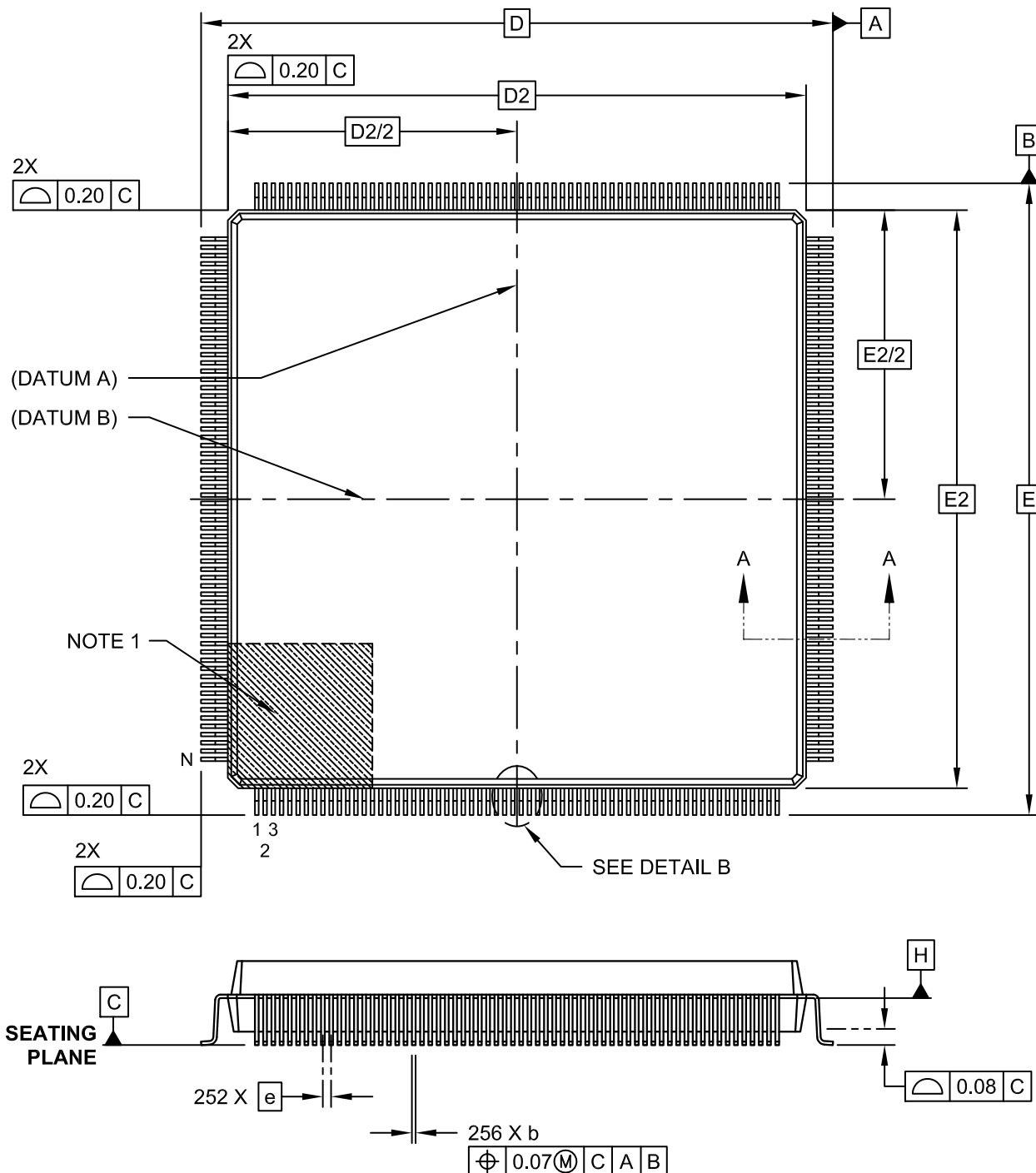



## Package Outlines and Dimensions

### 256-Lead Plastic Metric Quat Flatpack (PQ) - 28x28x3.40 mm Body [MQFP] 2.60 mm Footprint

**Note:** For the most current package drawings, please see the Microchip Packaging Specification located at <http://www.microchip.com/packaging>

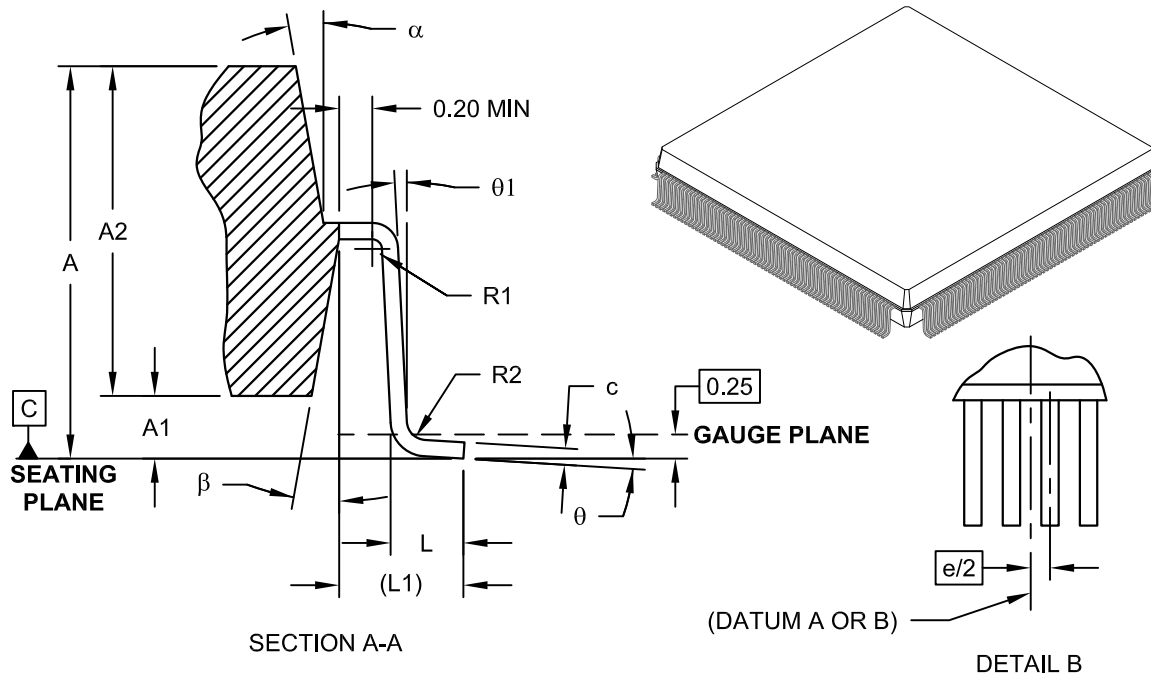

Dimension	Units	MILLIMETERS		
		MIN	NOM	MAX
Number of Leads	N	256		
Lead Pitch	e	0.40 BSC		
Overall Height	A	-	-	4.07
Molded Package Height	A2	3.20	3.40	3.60
Standoff	A1	0.15	0.25	0.35
Foot Length	L	0.45	0.60	0.75
Footprint	L1	1.30 (REF)		
Lead Angle	$\phi$	0°	3.5°	7°
Foot Angle	$\phi_1$	0°	-	-
Overall Width	E	30.60 BSC		
Overall Length	D	30.60 BSC		
Molded Body Width	E1	28.00 BSC		
Molded Body Length	D1	28.00 BSC		
Lead Thickness	c	0.09	-	0.20
Lead Width	b	0.13	-	0.23
Bend Radius	R1	0.08	-	-
Bend Radius	R2	0.25 TYP		
Mold Draft Angle Top	$\alpha$	9°	-	11°
Mold Draft Angle Bottom	$\beta$	9°	-	11°

**Notes:**

- Pin 1 visual index feature may vary, but must be located within the hatched area.
- Dimensioning and tolerancing per ASME Y14.5M.  
 BSC: Basic Dimension. Theoretically exact value shown without tolerances.  
 REF: Reference Dimension, usually without tolerance, for information purposes only.



**MICROCHIP**

---

---

**Package Outlines and Dimensions**

---

---

NOTES:

---

---

**Package Outlines and Dimensions**

---

---

**TQFP**

**Package Outlines and Dimensions**

**32-Lead Plastic Thin Quad Flatpack (PT) – 7x7x1.0 mm Body, 2.00 mm [TQFP]**

**Note:** For the most current package drawings, please see the Microchip Packaging Specification located at <http://www.microchip.com/packaging>

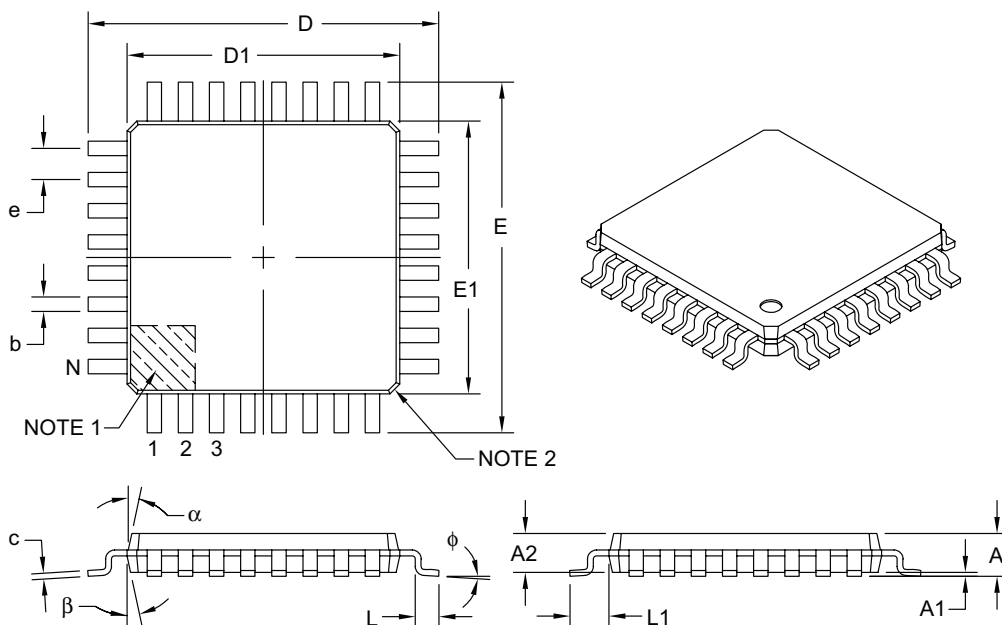

Dimension Limits	Units	MILLIMETERS		
		MIN	NOM	MAX
Number of Leads	N	32		
Lead Pitch	e	0.80 BSC		
Overall Height	A	–	–	1.20
Standoff	A1	0.05	–	0.15
Molded Package Thickness	A2	0.95	1.00	1.05
Foot Length	L	0.45	0.60	0.75
Footprint	L1	1.00 REF		
Foot Angle	φ	0°	3.5°	7°
Overall Width	E	9.00 BSC		
Overall Length	D	9.00 BSC		
Molded Package Width	E1	7.00 BSC		
Molded Package Length	D1	7.00 BSC		
Lead Thickness	c	0.09	–	0.20
Lead Width	b	0.30	0.37	0.45
Mold Draft Angle Top	α	11°	12°	13°
Mold Draft Angle Bottom	β	11°	12°	13°

**Notes:**

- Pin 1 visual index feature may vary, but must be located within the hatched area.
- Chamfers at corners are optional; size may vary.
- Dimensions D1 and E1 do not include mold flash or protrusions. Mold flash or protrusions shall not exceed 0.25 mm per side.
- Dimensioning and tolerancing per ASME Y14.5M.

BSC: Basic Dimension. Theoretically exact value shown without tolerances.

REF: Reference Dimension, usually without tolerance, for information purposes only.

Microchip Technology Drawing C04-074B

---



---

## Footprint Outlines and Dimensions

---



---

32-Lead Plastic Thin Quad Flatpack (PT) - 7x7x1.0 mm Body, 2.00 mm Footprint [TQFP]

**Note:** For the most current package drawings, please see the Microchip Packaging Specification located at <http://www.microchip.com/packaging>

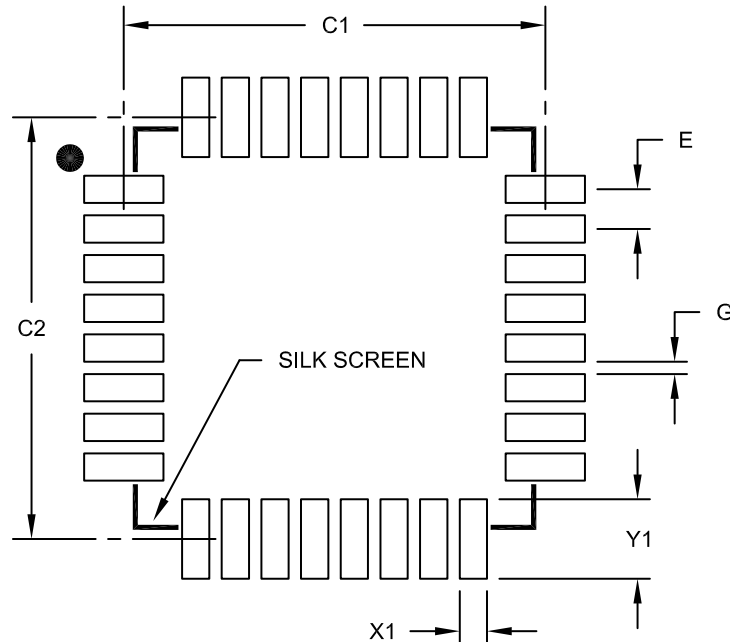

**RECOMMENDED LAND PATTERN**

Dimension Limits	Units	MILLIMETERS		
		MIN	NOM	MAX
Contact Pitch	E	0.80 BSC		
Contact Pad Spacing	C1		8.50	
Contact Pad Spacing	C2		8.50	
Contact Pad Width (X28)	X1			0.55
Contact Pad Length (X28)	Y1			1.60
Distance Between Pads	G	0.25		

**Notes:**

1. Dimensioning and tolerancing per ASME Y14.5M

BSC: Basic Dimension. Theoretically exact value shown without tolerances.

Microchip Technology Drawing No. C04-2074B

**Package Outlines and Dimensions**

**44-Lead Plastic Thin Quad Flatpack (PT) - 10x10x1.0 mm Body [TQFP]**

**Note:** For the most current package drawings, please see the Microchip Packaging Specification located at <http://www.microchip.com/packaging>

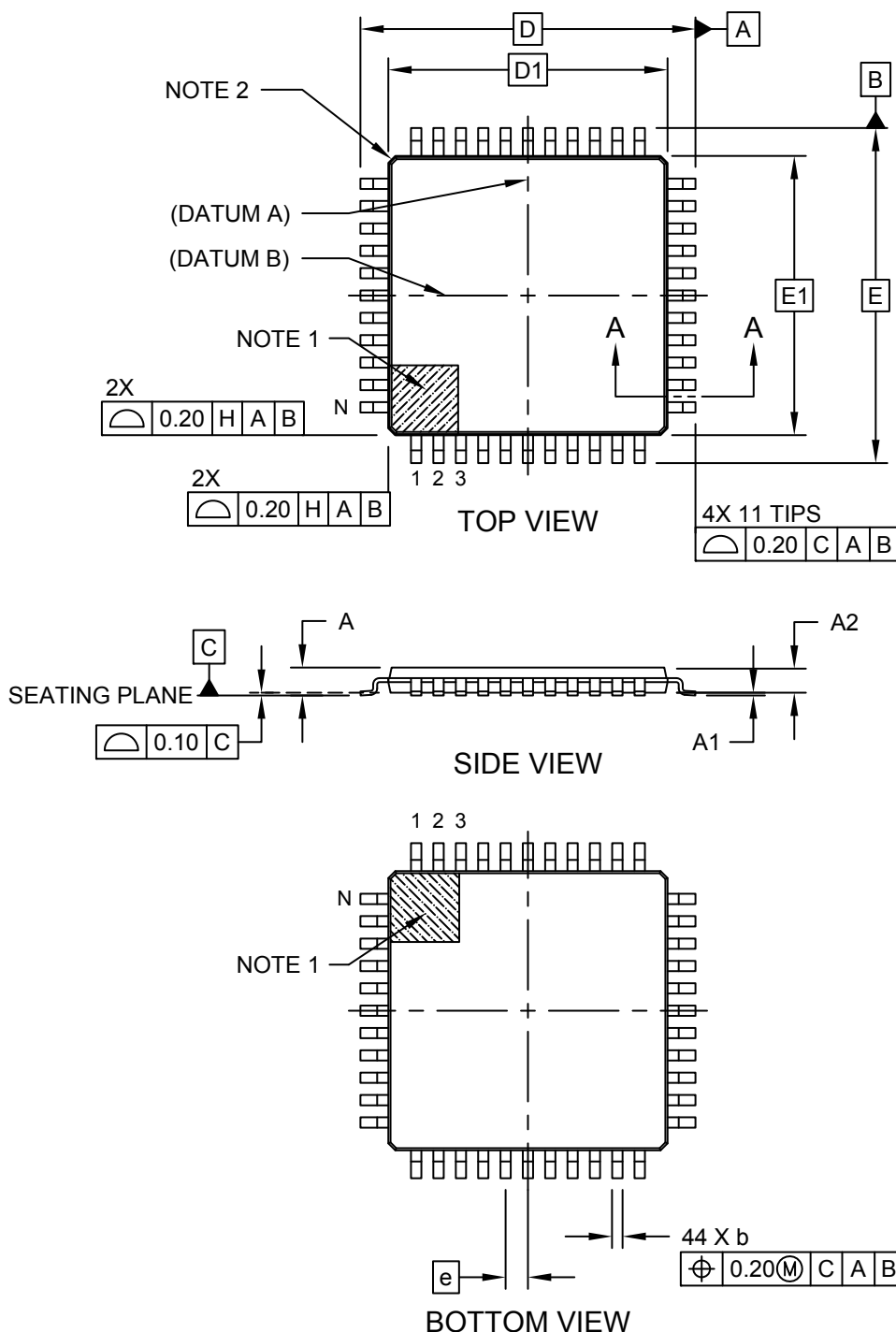

---



---

## Package Outlines and Dimensions

---



---

### 44-Lead Plastic Thin Quad Flatpack (PT) - 10x10x1.0 mm Body [TQFP]

**Note:** For the most current package drawings, please see the Microchip Packaging Specification located at <http://www.microchip.com/packaging>

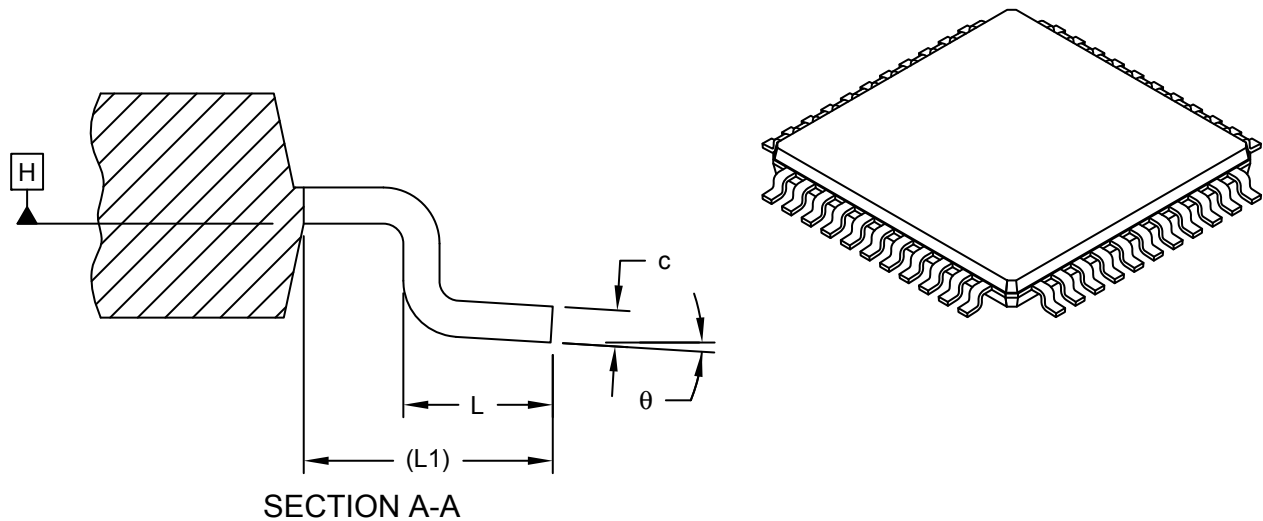

Dimension Limits	Units	MILLIMETERS		
		MIN	NOM	MAX
Number of Leads	N	44		
Lead Pitch	e	0.80 BSC		
Overall Height	A	-	-	1.20
Standoff	A1	0.05	-	0.15
Molded Package Thickness	A2	0.95	1.00	1.05
Overall Width	E	12.00 BSC		
Molded Package Width	E1	10.00 BSC		
Overall Length	D	12.00 BSC		
Molded Package Length	D1	10.00 BSC		
Lead Width	b	0.30	0.37	0.45
Lead Thickness	c	0.09	-	0.20
Lead Length	L	0.45	0.60	0.75
Footprint	L1	1.00 REF		
Foot Angle	θ	0°	3.5°	7°

**Notes:**

1. Pin 1 visual index feature may vary, but must be located within the hatched area.
2. Exact shape of each corner is optional.
3. Dimensioning and tolerancing per ASME Y14.5M

BSC: Basic Dimension. Theoretically exact value shown without tolerances.

REF: Reference Dimension, usually without tolerance, for information purposes only.

**Footprint Outlines and Dimensions**

**44-Lead Plastic Thin Quad Flatpack (PT) - 10X10X1 mm Body, 2.00 mm Footprint [TQFP]**

**Note:** For the most current package drawings, please see the Microchip Packaging Specification located at <http://www.microchip.com/packaging>

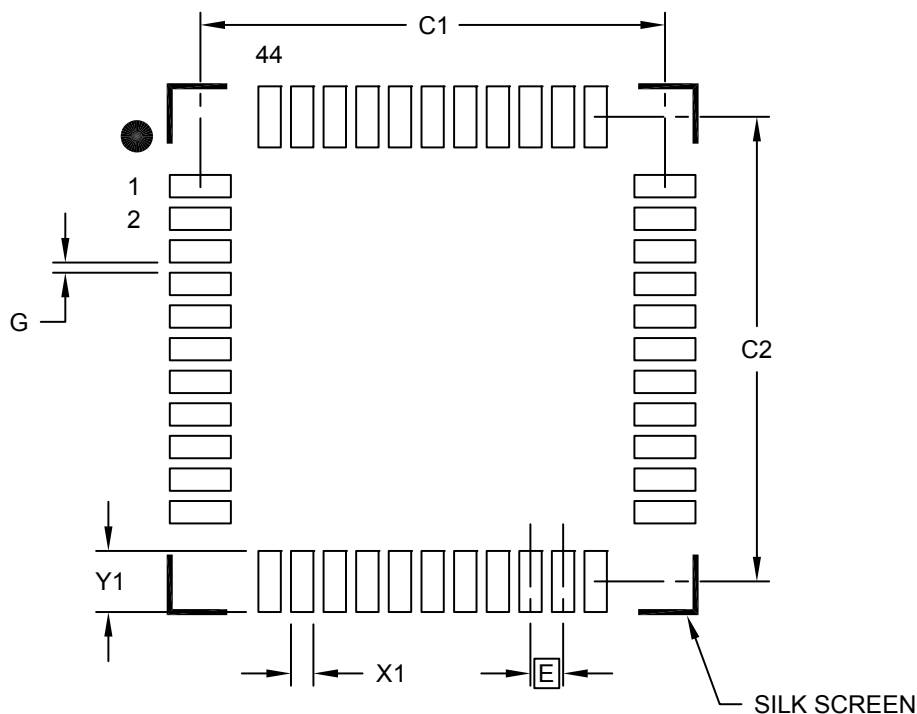

**RECOMMENDED LAND PATTERN**

Dimension Limits	Units	MILLIMETERS		
		MIN	NOM	MAX
Contact Pitch	E	0.80 BSC		
Contact Pad Spacing	C1		11.40	
Contact Pad Spacing	C2		11.40	
Contact Pad Width (X44)	X1			0.55
Contact Pad Length (X44)	Y1			1.50
Distance Between Pads	G	0.25		

Notes:

1. Dimensioning and tolerancing per ASME Y14.5M

BSC: Basic Dimension. Theoretically exact value shown without tolerances.

Microchip Technology Drawing No. C04-2076B



**Package Outlines and Dimensions**

**44-Lead Plastic Quad Flatpack (MW) - 10x10x1.0 mm Body  
[TQFP] With 4.5x4.5 mm Exposed Pad**

**Note:** For the most current package drawings, please see the Microchip Packaging Specification located at <http://www.microchip.com/packaging>

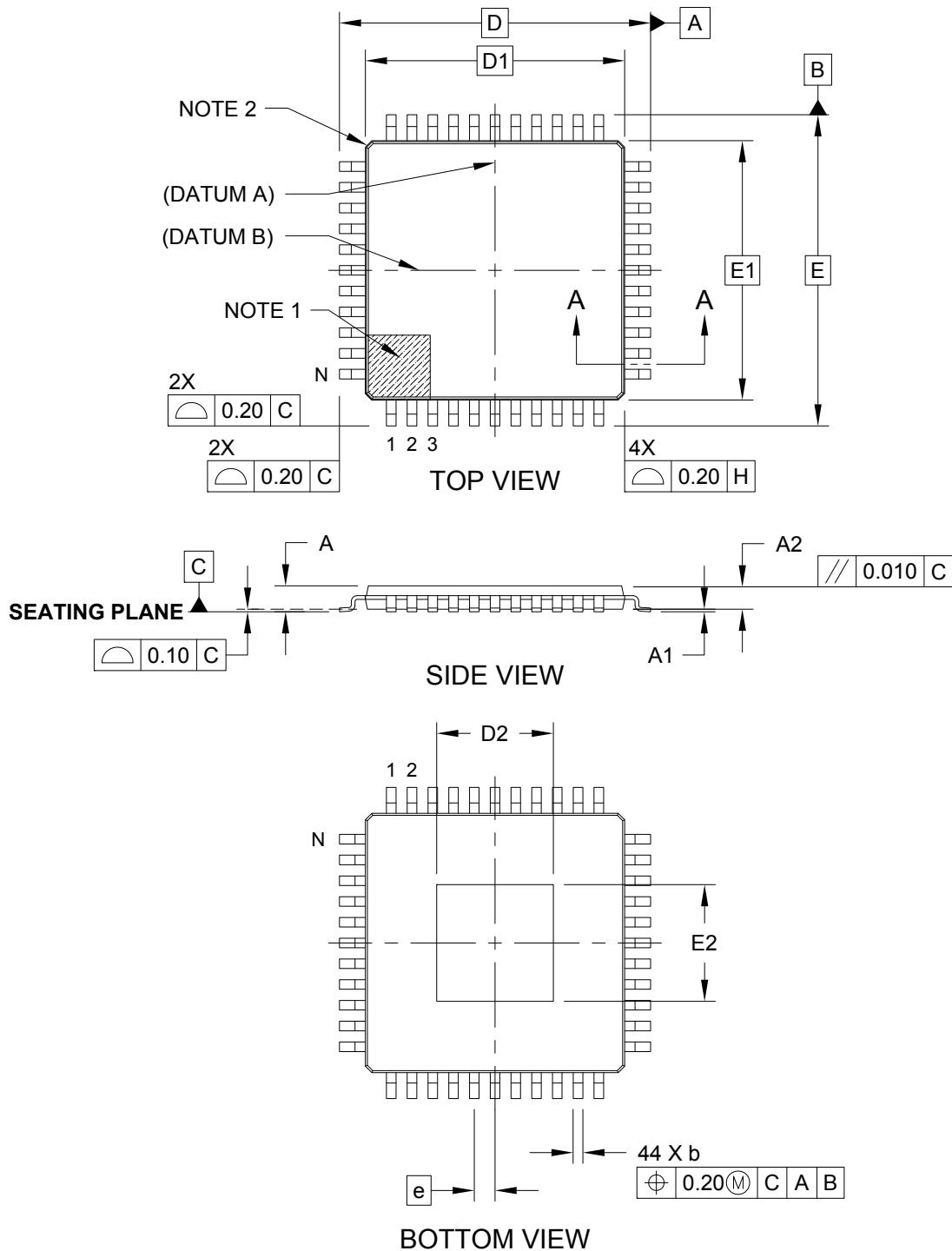

## Package Outlines and Dimensions

### 44-Lead Plastic Quad Flatpack (MW) - 10x10x1.0 mm Body [TQFP] With 4.5x4.5 mm Exposed Pad

**Note:** For the most current package drawings, please see the Microchip Packaging Specification located at <http://www.microchip.com/packaging>

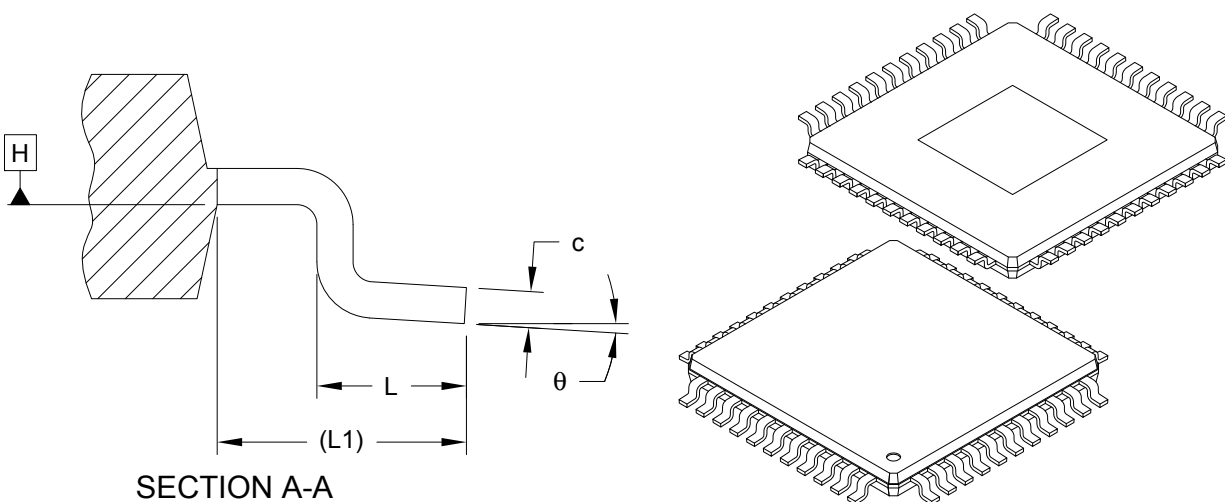

Dimension Limits	Units	MILLIMETERS		
		MIN	NOM	MAX
Number of Leads	N	44		
Pitch	e	0.80 BSC		
Overall Height	A	-	-	1.20
Standoff	A1	0.05	-	0.15
Molded Package Thickness	A2	0.95	1.00	1.05
Overall Width	E	12.00 BSC		
Molded Package Width	E1	10.00 BSC		
Exposed Pad Width	E2	4.40	4.50	4.60
Overall Length	D	12.00 BSC		
Molded Package Length	D1	10.00 BSC		
Exposed Pad Length	D2	4.40	4.50	4.60
Lead Width	b	0.30	0.37	0.45
Lead Thickness	c	0.09	-	0.20
Lead Length	L	0.45	0.60	0.75
Footprint	L1	1.00 REF		
Foot Angle	θ	0°	3.5°	7°

**Notes:**

- Pin 1 visual index feature may vary, but must be located within the hatched area.
- Exact shape of each corner is optional.
- Dimensioning and tolerancing per ASME Y14.5M

BSC: Basic Dimension. Theoretically exact value shown without tolerances.

REF: Reference Dimension, usually without tolerance, for information purposes only.

**Package Outlines and Dimensions**

**48-Lead Thin Quad Flatpack (PT) - 7x7x1.0 mm Body [TQFP] With Exposed Pad**

**Note:** For the most current package drawings, please see the Microchip Packaging Specification located at <http://www.microchip.com/packaging>

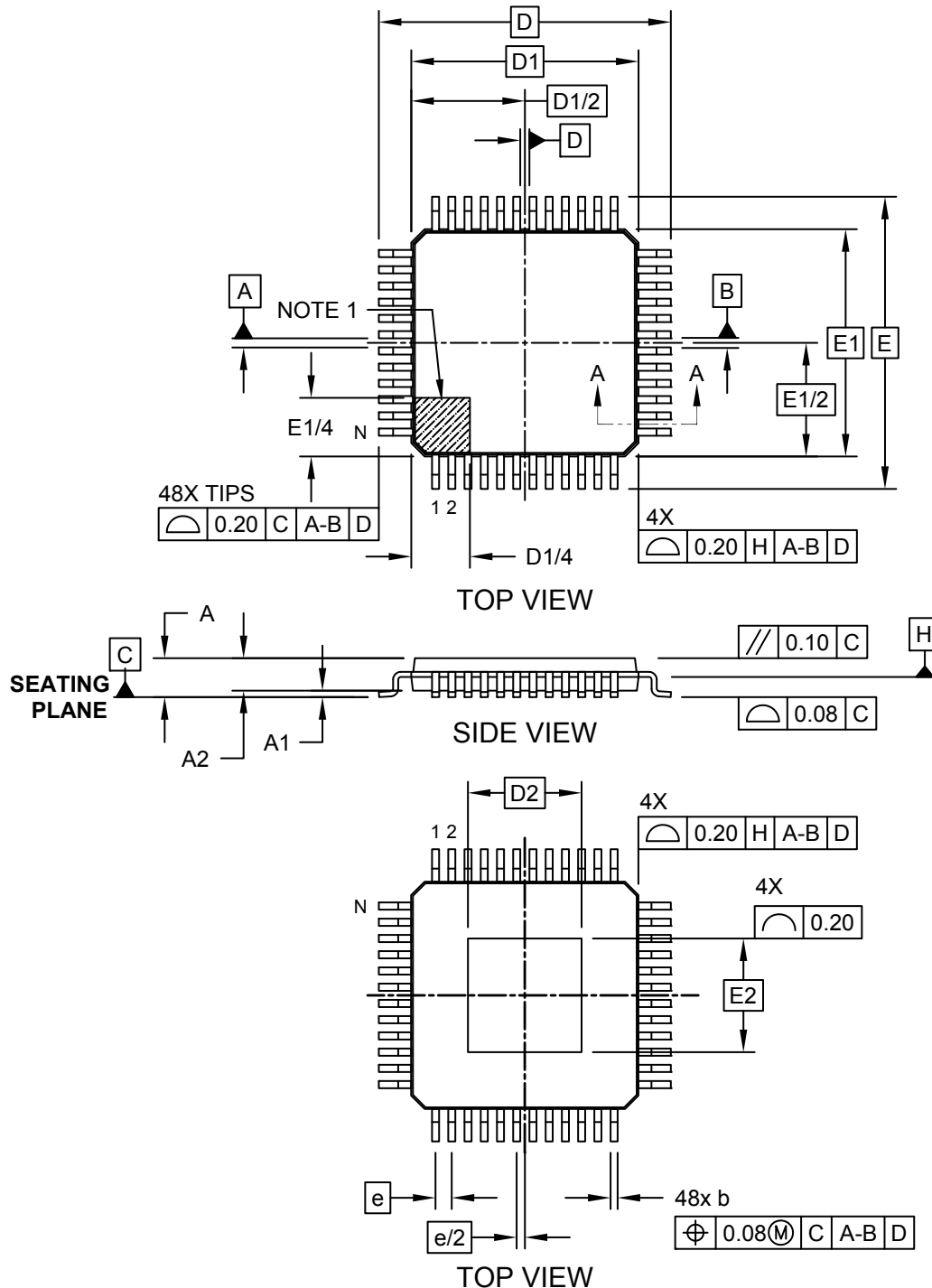

**Package Outlines and Dimensions**

**48-Lead Thin Quad Flatpack (PT) - 7x7x1.0 mm Body [TQFP] With Exposed Pad**

**Note:** For the most current package drawings, please see the Microchip Packaging Specification located at <http://www.microchip.com/packaging>

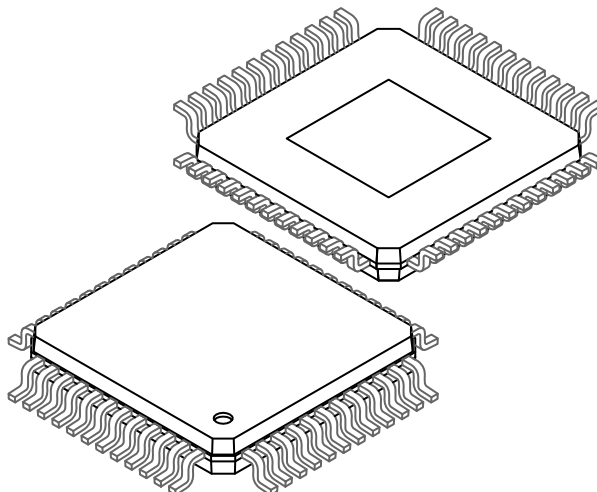
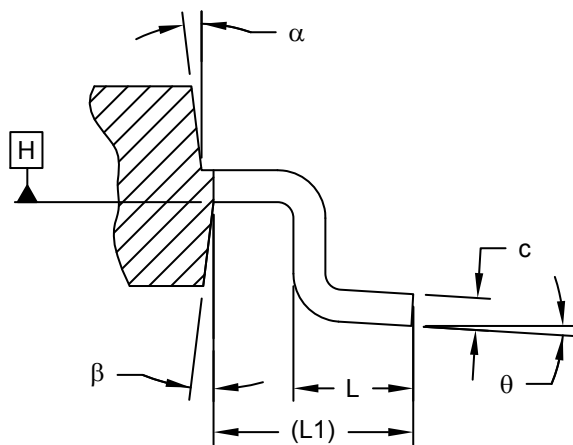

Dimension Limits	Units	MILLIMETERS		
		MIN	NOM	MAX
Number of Leads	N	48		
Lead Pitch	e	0.50 BSC		
Overall Height	A	-	-	1.20
Standoff	A1	0.05	-	0.15
Molded Package Thickness	A2	0.95	1.00	1.05
Foot Length	L	0.45	0.60	0.75
Footprint	L1	1.00 REF		
Foot Angle	$\phi$	0°	3.5°	7°
Overall Width	E	9.00 BSC		
Overall Length	D	9.00 BSC		
Molded Package Width	E1	7.00 BSC		
Molded Package Length	D1	7.00 BSC		
Exposed Pad Width	E2	3.50 BSC		
Exposed Pad Length	D2	3.50 BSC		
Lead Thickness	c	0.09	-	0.16
Lead Width	b	0.17	0.22	0.27
Mold Draft Angle Top	$\alpha$	11°	12°	13°
Mold Draft Angle Bottom	$\beta$	11°	12°	13°

**Notes:**

- Pin 1 visual index feature may vary, but must be located within the hatched area.
- Chamfers at corners are optional; size may vary.
- Dimensions D1 and E1 do not include mold flash or protrusions. Mold flash or protrusions shall not exceed 0.25mm per side.
- Dimensioning and tolerancing per ASME Y14.5M  
 BSC: Basic Dimension. Theoretically exact value shown without tolerances.  
 REF: Reference Dimension, usually without tolerance, for information purposes only.

---



---

## Footprint Outlines and Dimensions

---



---

### 48-Lead Thin Quad Flatpack (PT) - 7x7x1.0 mm Body [TQFP] With Thermal Tab

**Note:** For the most current package drawings, please see the Microchip Packaging Specification located at <http://www.microchip.com/packaging>

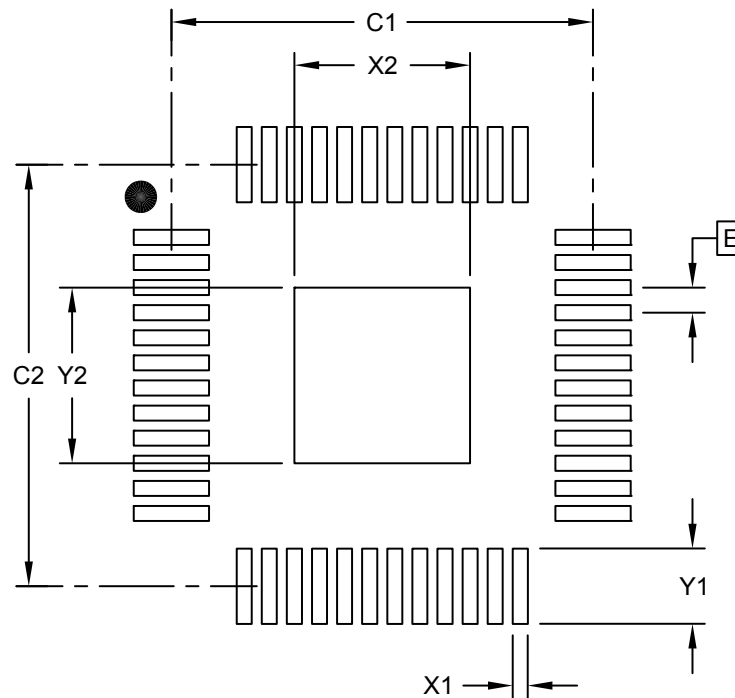

**RECOMMENDED LAND PATTERN**

Dimension Limits	Units	MILLIMETERS		
		MIN	NOM	MAX
Contact Pitch	E	0.50 BSC		
Optional Center Tab Width	X2		3.50	
Optional Center Tab Length	Y2		3.50	
Contact Pad Spacing	C1		8.40	
Contact Pad Spacing	C2		8.40	
Contact Pad Width (X48)	X1			0.30
Contact Pad Length (X48)	Y1			1.50

**Notes:**

1. Dimensioning and tolerancing per ASME Y14.5M

BSC: Basic Dimension. Theoretically exact value shown without tolerances.

Microchip Technology Drawing No. C04-2183A

**Package Outlines and Dimensions**

**48-Lead Thin Quad Flatpack (PT) - 7x7x1.0 mm Body [TQFP]**

**Note:** For the most current package drawings, please see the Microchip Packaging Specification located at <http://www.microchip.com/packaging>

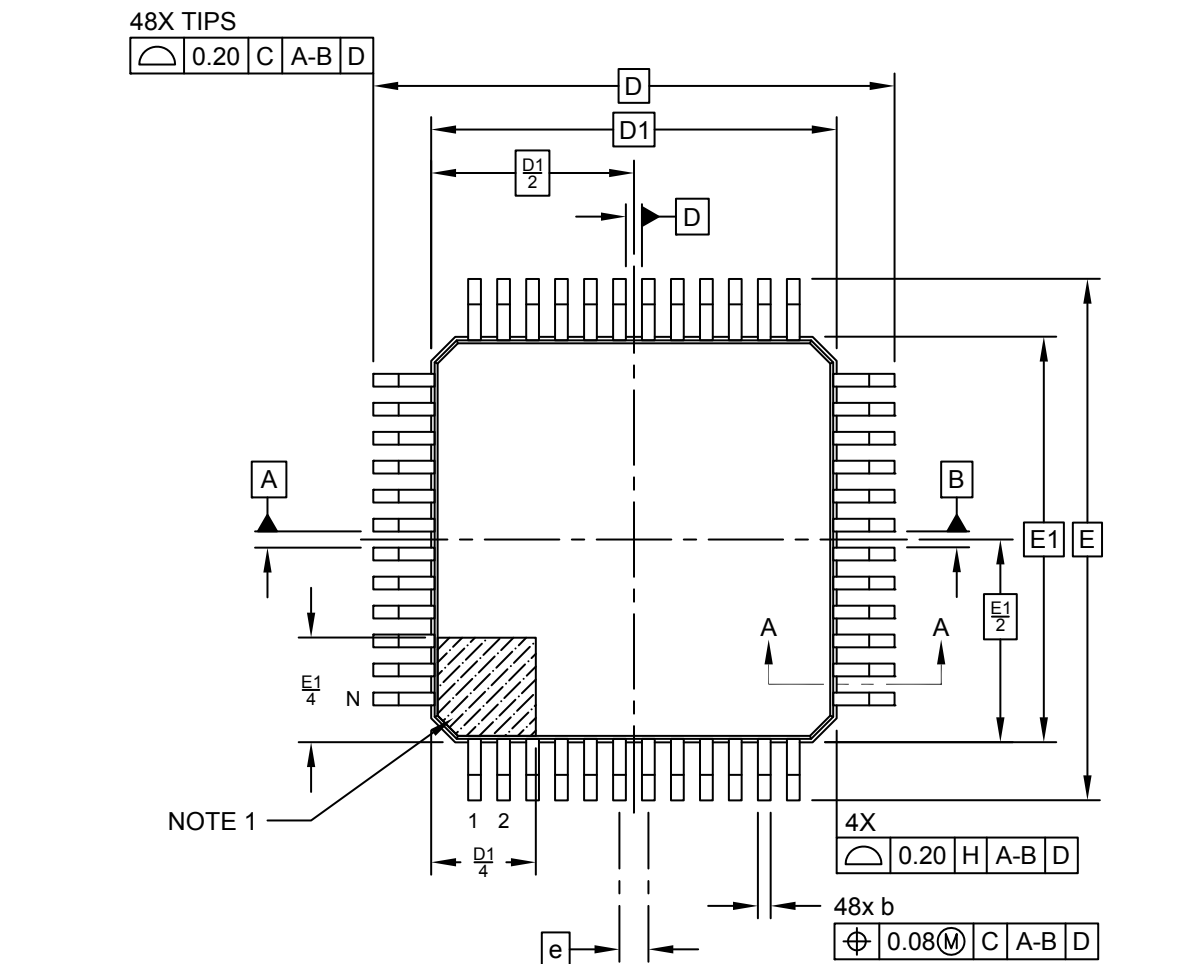

TOP VIEW

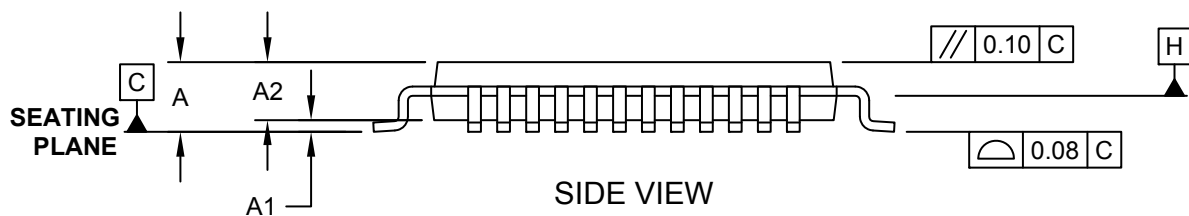

SIDE VIEW

---



---

## Package Outlines and Dimensions

---



---

### 48-Lead Thin Quad Flatpack (PT) - 7x7x1.0 mm Body [TQFP]

**Note:** For the most current package drawings, please see the Microchip Packaging Specification located at <http://www.microchip.com/packaging>

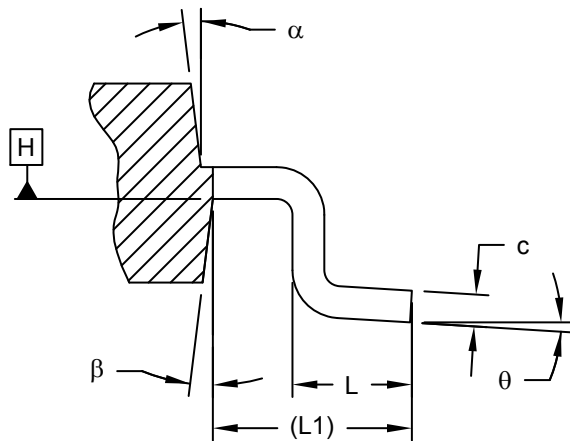

SECTION A-A

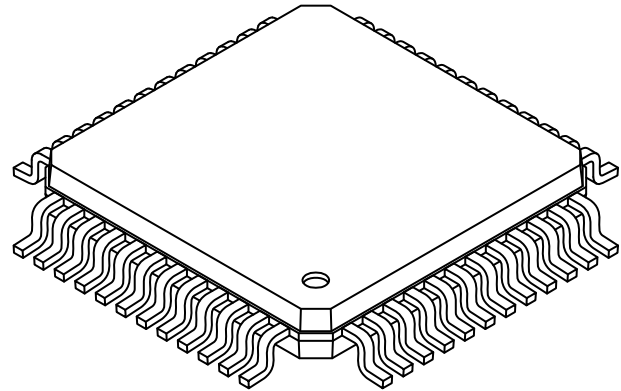

Units		MILLIMETERS		
Dimension Limits		MIN	NOM	MAX
Number of Leads	N	48		
Lead Pitch	e	0.50 BSC		
Overall Height	A	-	-	1.20
Standoff	A1	0.05	-	0.15
Molded Package Thickness	A2	0.95	1.00	1.05
Foot Length	L	0.45	0.60	0.75
Footprint	L1	1.00 REF		
Foot Angle	φ	0°	3.5°	7°
Overall Width	E	9.00 BSC		
Overall Length	D	9.00 BSC		
Molded Package Width	E1	7.00 BSC		
Molded Package Length	D1	7.00 BSC		
Lead Thickness	c	0.09	-	0.16
Lead Width	b	0.17	0.22	0.27
Mold Draft Angle Top	α	11°	12°	13°
Mold Draft Angle Bottom	β	11°	12°	13°

**Notes:**

1. Pin 1 visual index feature may vary, but must be located within the hatched area.
2. Chamfers at corners are optional; size may vary.
3. Dimensions D1 and E1 do not include mold flash or protrusions. Mold flash or protrusions shall not exceed 0.25mm per side.
4. Dimensioning and tolerancing per ASME Y14.5M  
 BSC: Basic Dimension. Theoretically exact value shown without tolerances.  
 REF: Reference Dimension, usually without tolerance, for information purposes only.
5. Datums  $\overline{A-B}$  and  $\overline{D}$  to be determined at center line between leads where leads exit plastic body at datum plane  $\overline{H}$

**Footprint Outlines and Dimensions**

**48-Lead Thin Quad Flatpack (PT) - 7x7x1.0 mm Body [TQFP]**

**Note:** For the most current package drawings, please see the Microchip Packaging Specification located at <http://www.microchip.com/packaging>

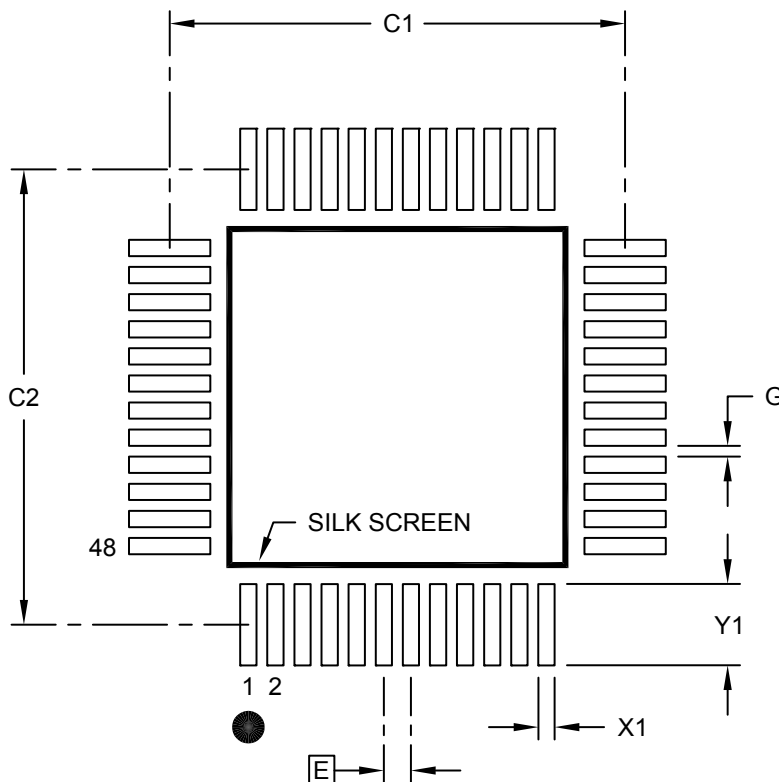

**RECOMMENDED LAND PATTERN**

Dimension Limits	Units	MILLIMETERS		
		MIN	NOM	MAX
Contact Pitch	E	0.50 BSC		
Contact Pad Spacing	C1		8.40	
Contact Pad Spacing	C2		8.40	
Contact Pad Width (X48)	X1			0.30
Contact Pad Length (X48)	Y1			1.50
Distance Between Pads	G	0.20		

**Notes:**

1. Dimensioning and tolerancing per ASME Y14.5M  
BSC: Basic Dimension. Theoretically exact value shown without tolerances.
2. For best soldering results, thermal vias, if used, should be filled or tented to avoid solder loss during reflow process



**Package Outlines and Dimensions**

**48-Lead Thin Quad Flatpack (Y8) - 7x7x1.0 mm Body [TQFP]**

**Note:** For the most current package drawings, please see the Microchip Packaging Specification located at <http://www.microchip.com/packaging>

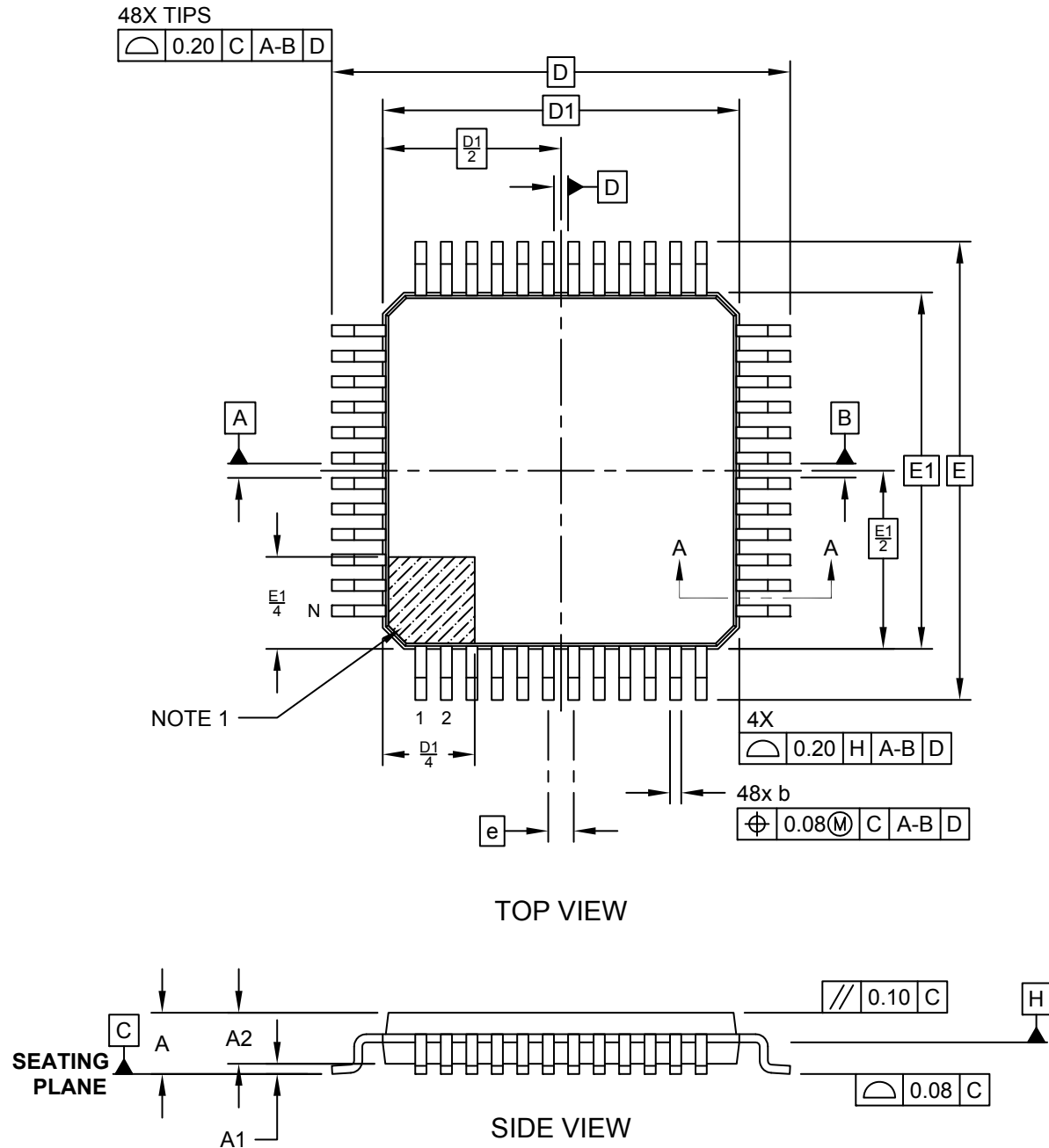

**Package Outlines and Dimensions**

**48-Lead Thin Quad Flatpack (Y8) - 7x7x1.0 mm Body [TQFP]**

**Note:** For the most current package drawings, please see the Microchip Packaging Specification located at <http://www.microchip.com/packaging>

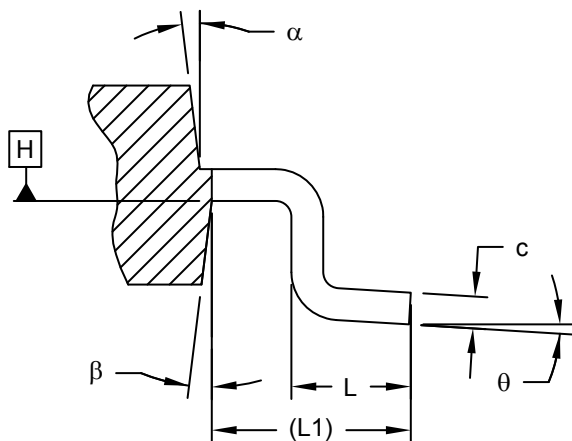

SECTION A-A

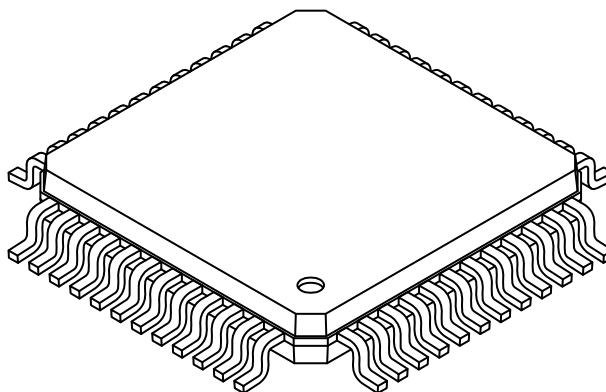

Dimension Limits	Units	MILLIMETERS		
		MIN	NOM	MAX
Number of Leads	N	48		
Lead Pitch	e	0.50 BSC		
Overall Height	A	-	-	1.20
Standoff	A1	0.05	-	0.15
Molded Package Thickness	A2	0.95	1.00	1.05
Foot Length	L	0.45	0.60	0.75
Footprint	L1	1.00 REF		
Foot Angle	φ	0°	3.5°	7°
Overall Width	E	9.00 BSC		
Overall Length	D	9.00 BSC		
Molded Package Width	E1	7.00 BSC		
Molded Package Length	D1	7.00 BSC		
Lead Thickness	c	0.09	-	0.16
Lead Width	b	0.17	0.22	0.27
Mold Draft Angle Top	α	11°	12°	13°
Mold Draft Angle Bottom	β	11°	12°	13°

**Notes:**

- Pin 1 visual index feature may vary, but must be located within the hatched area.
- Chamfers at corners are optional; size may vary.
- Dimensions D1 and E1 do not include mold flash or protrusions. Mold flash or protrusions shall not exceed 0.25mm per side.
- Dimensioning and tolerancing per ASME Y14.5M  
 BSC: Basic Dimension. Theoretically exact value shown without tolerances.  
 REF: Reference Dimension, usually without tolerance, for information purposes only.
- Datums  $\overline{A-B}$  and  $\overline{D}$  to be determined at center line between leads where leads exit plastic body at datum plane  $\overline{H}$

---



---

## Footprint Outlines and Dimensions

---



---

### 48-Lead Thin Quad Flatpack (Y8) - 7x7x1.0 mm Body [TQFP]

**Note:** For the most current package drawings, please see the Microchip Packaging Specification located at <http://www.microchip.com/packaging>

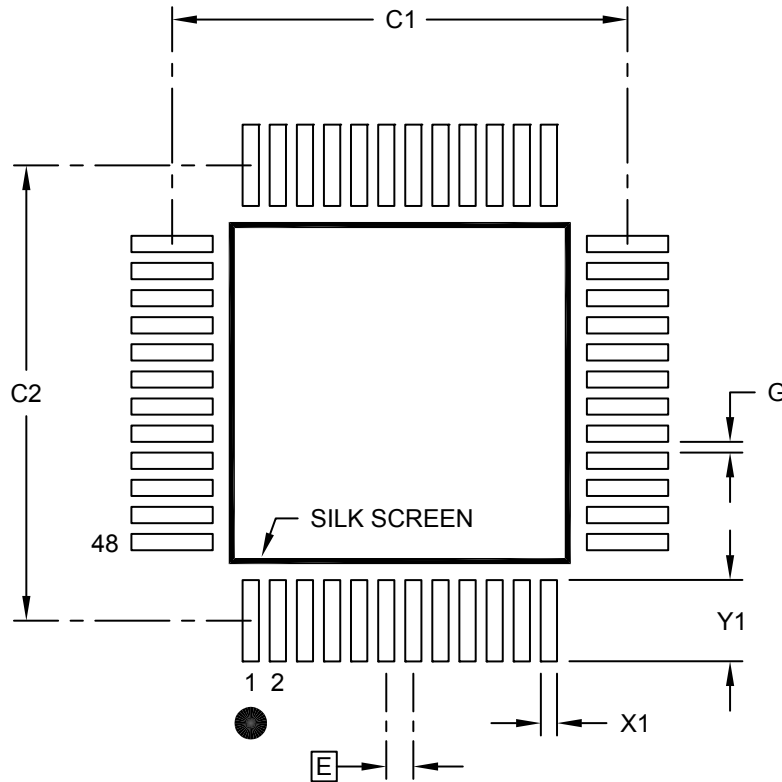

### RECOMMENDED LAND PATTERN

		Units	MILLIMETERS		
		Dimension Limits	MIN	NOM	MAX
Contact Pitch	E	0.50 BSC			
Contact Pad Spacing	C1		8.40		
Contact Pad Spacing	C2		8.40		
Contact Pad Width (X48)	X1				0.30
Contact Pad Length (X48)	Y1				1.50
Distance Between Pads	G	0.20			

**Notes:**

1. Dimensioning and tolerancing per ASME Y14.5M  
     BSC: Basic Dimension. Theoretically exact value shown without tolerances.
2. For best soldering results, thermal vias, if used, should be filled or tented to avoid solder loss during reflow process

**Package Outlines and Dimensions**

**64-Lead Plastic Thin Quad Flatpack (PF) – 14x14x1 mm Body, 2.00 mm [TQFP]**

**Note:** For the most current package drawings, please see the Microchip Packaging Specification located at <http://www.microchip.com/packaging>

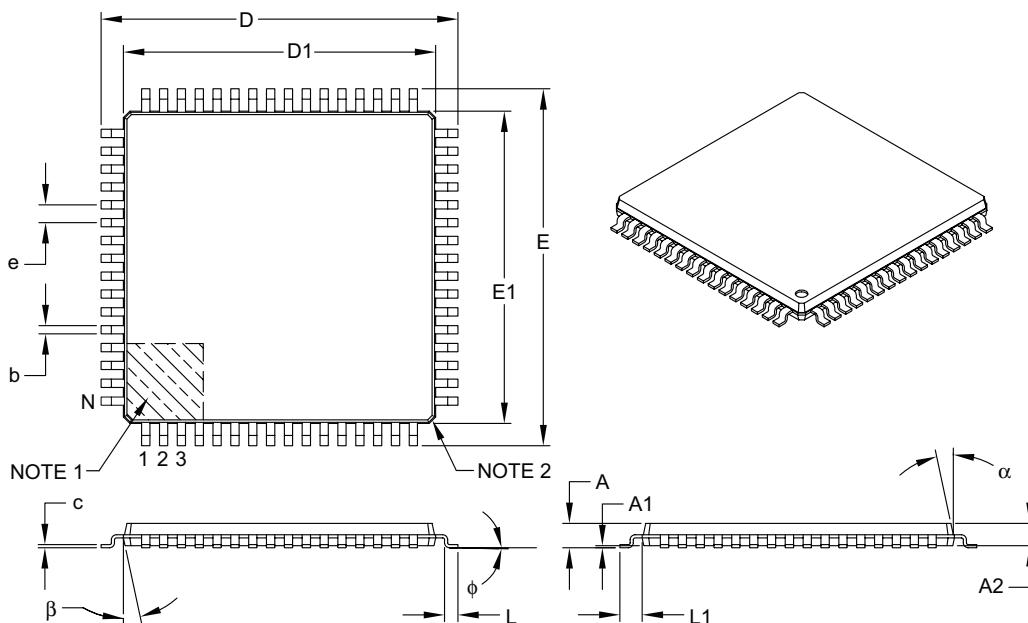

Dimension Limits	Units	MILLIMETERS		
		MIN	NOM	MAX
Number of Leads	N	64		
Lead Pitch	e	0.80 BSC		
Overall Height	A	–	–	1.20
Molded Package Thickness	A2	0.95	1.00	1.05
Standoff	A1	0.05	–	0.15
Foot Length	L	0.45	0.60	0.75
Footprint	L1	1.00 REF		
Foot Angle	φ	0°	3.5°	7°
Overall Width	E	16.00 BSC		
Overall Length	D	16.00 BSC		
Molded Package Width	E1	14.00 BSC		
Molded Package Length	D1	14.00 BSC		
Lead Thickness	c	0.09	–	0.20
Lead Width	b	0.30	0.37	0.45
Mold Draft Angle Top	α	11°	12°	13°
Mold Draft Angle Bottom	β	11°	12°	13°

**Notes:**

- Pin 1 visual index feature may vary, but must be located within the hatched area.
- Chamfers at corners are optional; size may vary.
- Dimensions D1 and E1 do not include mold flash or protrusions. Mold flash or protrusions shall not exceed 0.25 mm per side.
- Dimensioning and tolerancing per ASME Y14.5M.

BSC: Basic Dimension. Theoretically exact value shown without tolerances.

REF: Reference Dimension, usually without tolerance, for information purposes only.

Microchip Technology Drawing C04-066B

---



---

## Footprint Outlines and Dimensions

---



---

### 64-Lead Plastic Thin Quad Flatpack (PF) – 14x14x1 mm Body, 2.00 mm [TQFP]

**Note:** For the most current package drawings, please see the Microchip Packaging Specification located at <http://www.microchip.com/packaging>

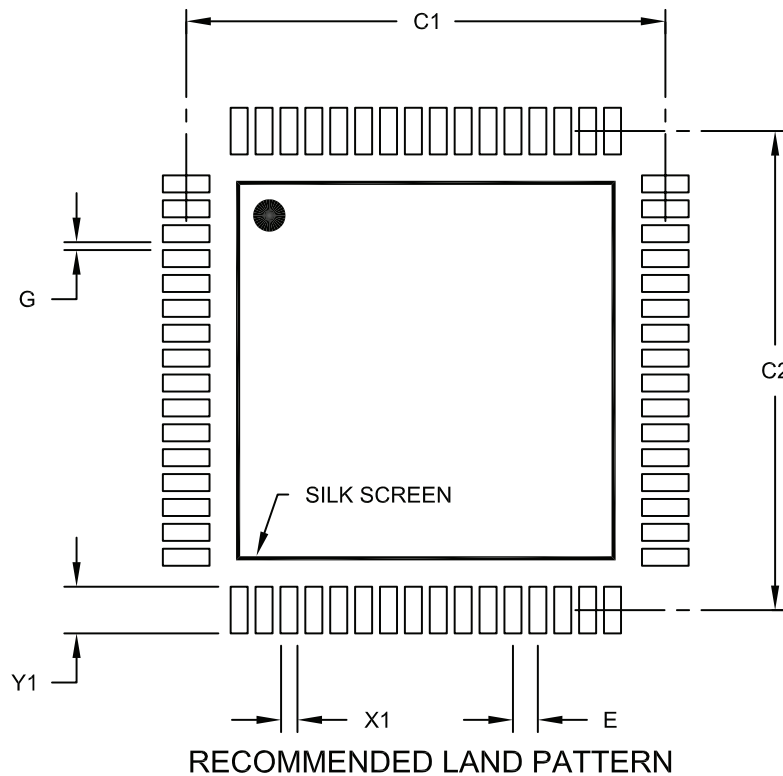

	Units	MILLIMETERS		
		MIN	NOM	MAX
Dimension Limits				
Contact Pitch	E	0.80 BSC		
Contact Pad Spacing	C1		15.40	
Contact Pad Spacing	C2		15.40	
Contact Pad Width (X64)	X1			0.55
Contact Pad Length (X64)	Y1			1.50
Distance Between Pads	G	0.25		

**Notes:**

1. Dimensioning and tolerancing per ASME Y14.5M

BSC: Basic Dimension. Theoretically exact value shown without tolerances.

Microchip Technology Drawing No. C04-2066A

**Package Outlines and Dimensions**

**64-Lead Plastic Thin Quad Flatpack (PT)-10x10x1 mm Body, 2.00 mm Footprint [TQFP]**

**Note:** For the most current package drawings, please see the Microchip Packaging Specification located at <http://www.microchip.com/packaging>

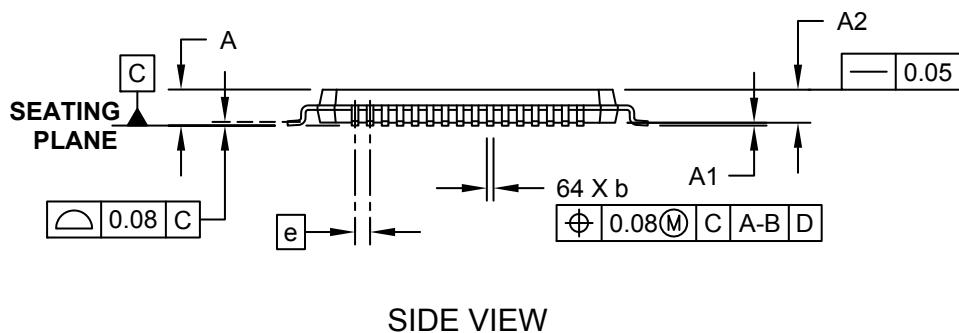
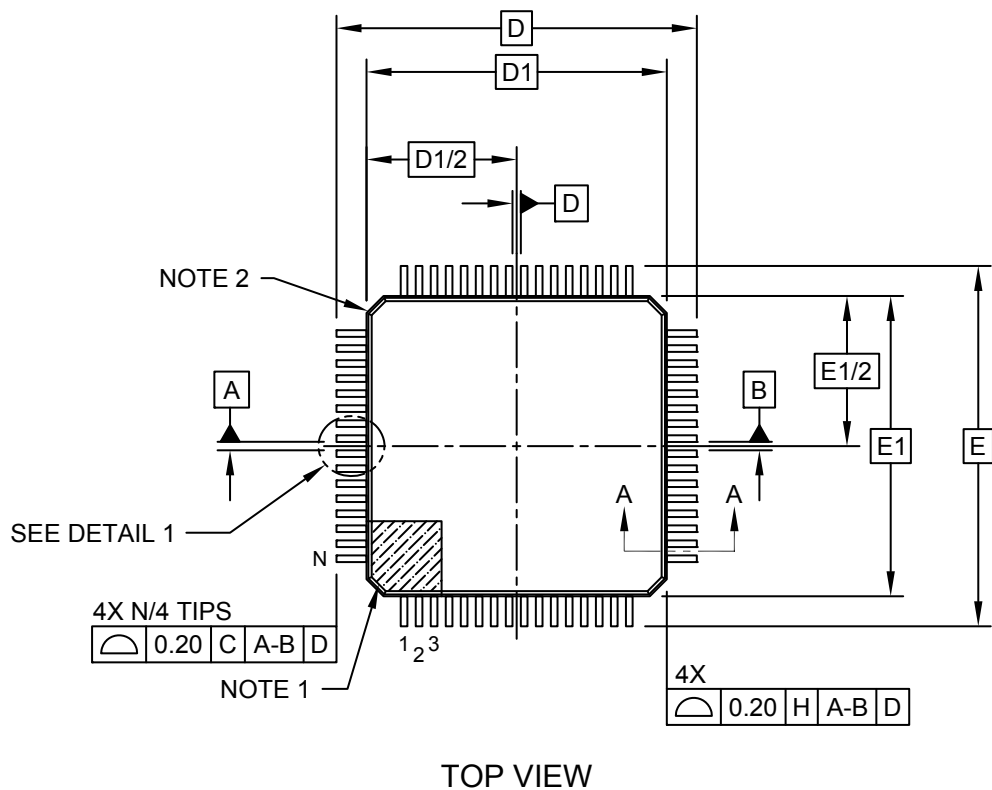

---



---

## Package Outlines and Dimensions

---



---

### 64-Lead Plastic Thin Quad Flatpack (PT)-10x10x1 mm Body, 2.00 mm Footprint [TQFP]

**Note:** For the most current package drawings, please see the Microchip Packaging Specification located at <http://www.microchip.com/packaging>

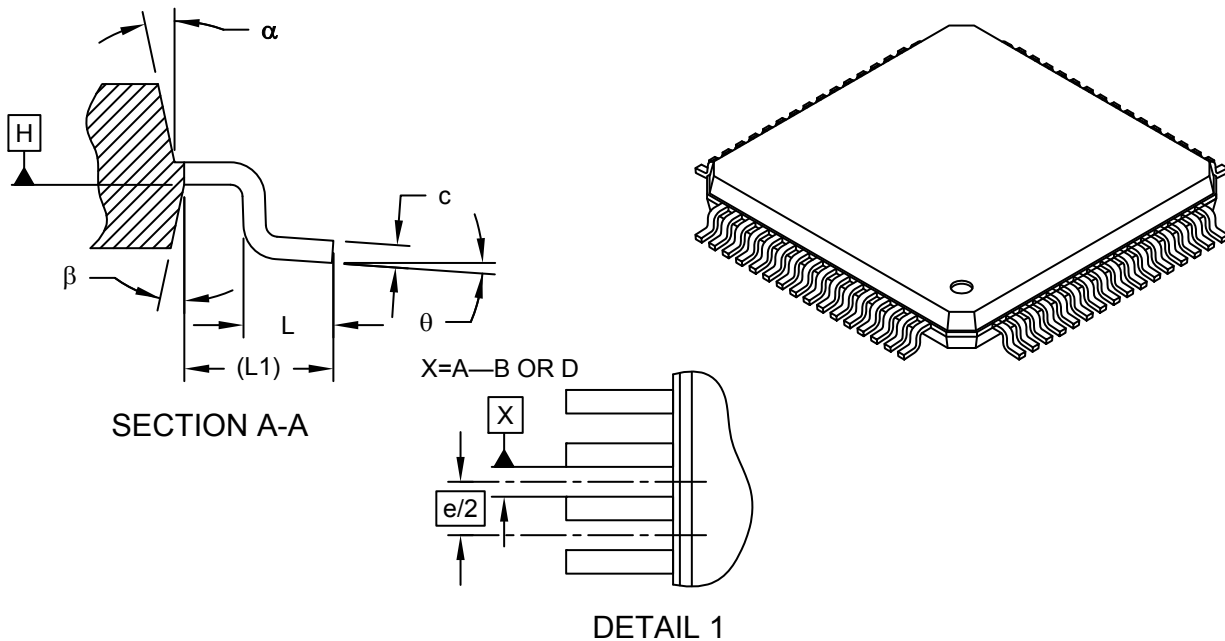

Dimension Limits	Units	MILLIMETERS		
		MIN	NOM	MAX
Number of Leads	N	64		
Lead Pitch	e	0.50 BSC		
Overall Height	A	-	-	1.20
Molded Package Thickness	A2	0.95	1.00	1.05
Standoff	A1	0.05	-	0.15
Foot Length	L	0.45	0.60	0.75
Footprint	L1	1.00 REF		
Foot Angle	φ	0°	3.5°	7°
Overall Width	E	12.00 BSC		
Overall Length	D	12.00 BSC		
Molded Package Width	E1	10.00 BSC		
Molded Package Length	D1	10.00 BSC		
Lead Thickness	c	0.09	-	0.20
Lead Width	b	0.17	0.22	0.27
Mold Draft Angle Top	α	11°	12°	13°
Mold Draft Angle Bottom	β	11°	12°	13°

**Notes:**

1. Pin 1 visual index feature may vary, but must be located within the hatched area.
2. Chamfers at corners are optional; size may vary.
3. Dimensions D1 and E1 do not include mold flash or protrusions. Mold flash or protrusions shall not exceed 0.25mm per side.
4. Dimensioning and tolerancing per ASME Y14.5M

BSC: Basic Dimension. Theoretically exact value shown without tolerances.

REF: Reference Dimension, usually without tolerance, for information purposes only.

**Footprint Outlines and Dimensions**

**64-Lead Plastic Thin Quad Flatpack (PT)-10x10x1 mm Body, 2.00 mm Footprint [TQFP]**

**Note:** For the most current package drawings, please see the Microchip Packaging Specification located at <http://www.microchip.com/packaging>

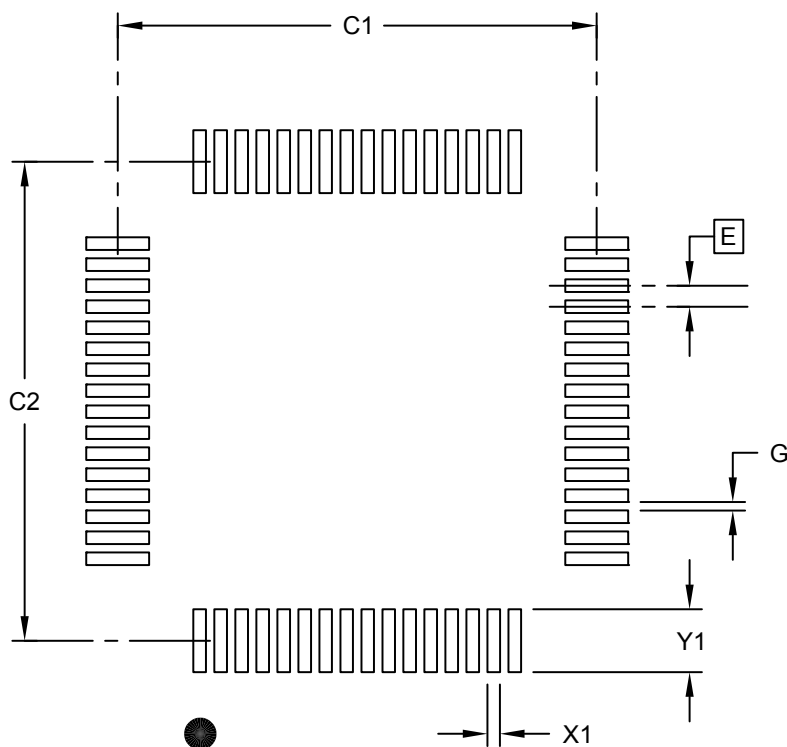

**RECOMMENDED LAND PATTERN**

Dimension Limits	Units	MILLIMETERS		
		MIN	NOM	MAX
Contact Pitch	E	0.50 BSC		
Contact Pad Spacing	C1		11.40	
Contact Pad Spacing	C2		11.40	
Contact Pad Width (X28)	X1			0.30
Contact Pad Length (X28)	Y1			1.50
Distance Between Pads	G	0.20		

**Notes:**

1. Dimensioning and tolerancing per ASME Y14.5M

BSC: Basic Dimension. Theoretically exact value shown without tolerances.



**Package Outlines and Dimensions**

**64-Lead Plastic Thin Quad Flatpack (JVX) - 10x10x1 mm Body [TQFP]  
2.00 mm Footprint, 5.7x5.7mm Exposed Pad**

**Note:** For the most current package drawings, please see the Microchip Packaging Specification located at <http://www.microchip.com/packaging>

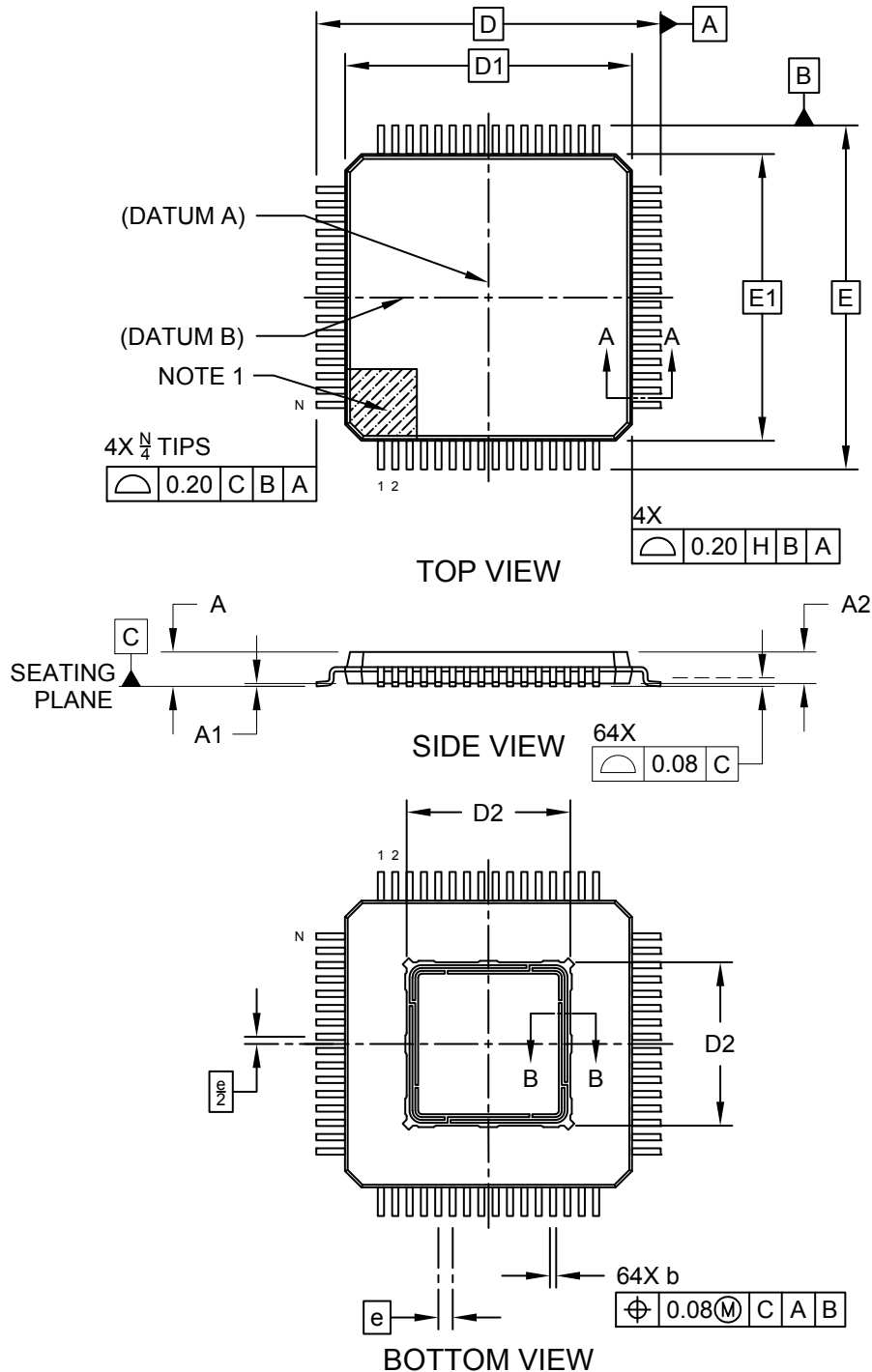

**Package Outlines and Dimensions**

**64-Lead Plastic Thin Quad Flatpack (JVX) - 10x10x1 mm Body [TQFP]  
2.00 mm Footprint, 5.7x5.7mm Exposed Pad**

**Note:** For the most current package drawings, please see the Microchip Packaging Specification located at <http://www.microchip.com/packaging>

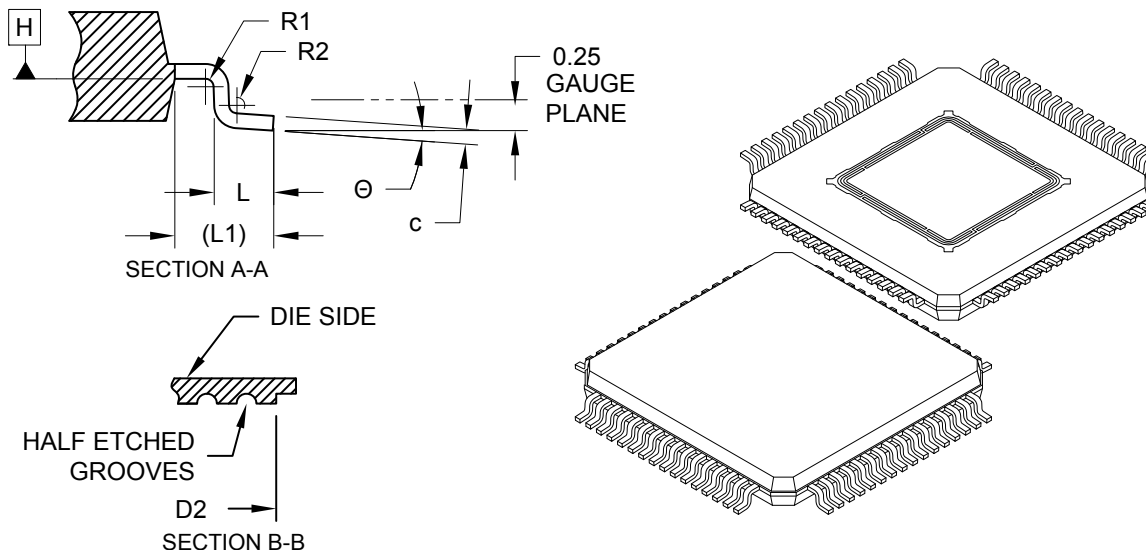

Dimension Limits	Units	MILLIMETERS		
		MIN	NOM	MAX
Number of Leads	N	64		
Lead Pitch	e	0.50 BSC		
Overall Height	A	-	-	1.20
Molded Package Thickness	A2	0.95	1.00	1.05
Standoff	A1	0.05	-	0.15
Overall Package Length	D	12.00 BSC		
Molded Package Length	D1	10.00 BSC		
Exposed Pad Length	D2	5.65	5.70	5.75
Overall Package Width	E	12.00 BSC		
Molded Package Width	E1	10.00 BSC		
Exposed Pad Width	E2	5.65	5.70	5.75
Foot Length	L	0.45	0.60	0.75
Footprint	L1	1.00 REF		
Lead Thickness	c	0.09	-	0.20
Lead Width	b	0.17	0.22	0.27
Lead Bend Radius	R1	0.08	-	-
Lead Bend Radius	R2	0.08	-	0.20
Foot Angle	Θ	0°	3.5°	7°

**Notes:**

- Pin 1 visual index feature may vary, but must be located within the hatched area.
- Chamfers at corners are optional; size may vary.
- Dimensions D1 and E1 do not include mold flash or protrusions. Mold flash or protrusions shall not exceed 0.25mm per side.
- Dimensioning and tolerancing per ASME Y14.5M

BSC: Basic Dimension. Theoretically exact value shown without tolerances.

REF: Reference Dimension, usually without tolerance, for information purposes only.

---



---

## Footprint Outlines and Dimensions

---



---

### 64-Lead Plastic Thin Quad Flatpack (JVX) - 10x10x1 mm Body [TQFP] 2.00 mm Footprint, 5.7x5.7mm Exposed Pad

**Note:** For the most current package drawings, please see the Microchip Packaging Specification located at <http://www.microchip.com/packaging>

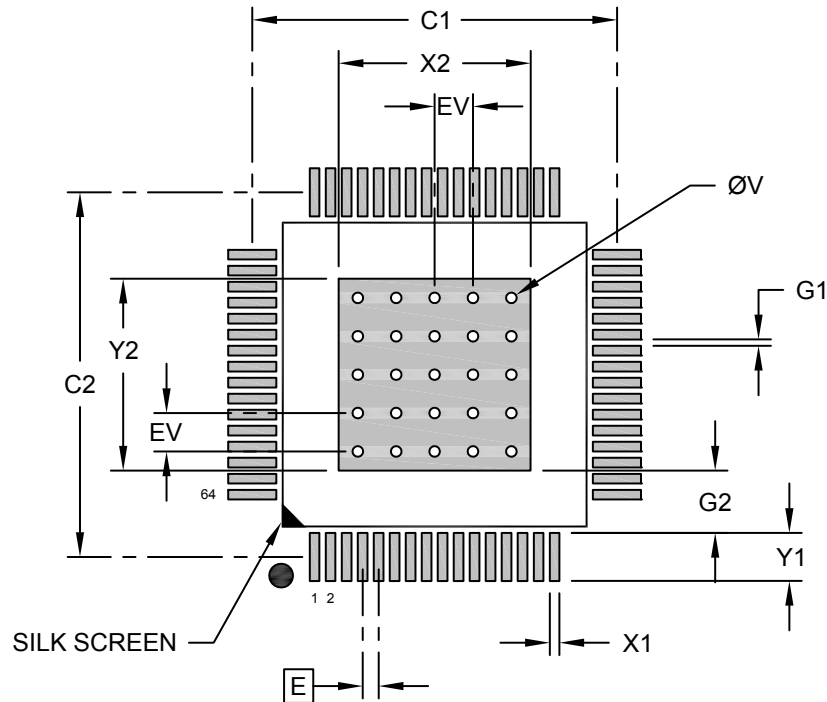

### RECOMMENDED LAND PATTERN

	Units	MILLIMETERS		
		Dimension Limits		
		MIN	NOM	MAX
Contact Pitch	E	0.50 BSC		
Optional Center Pad Width	X2			6.00
Optional Center Pad Length	Y2			6.00
Contact Pad Spacing	C1		11.40	
Contact Pad Spacing	C2		11.40	
Contact Pad Width (X64)	X1			0.30
Contact Pad Length (X64)	Y1			1.50
Contact Pad to Contact Pad (X60)	G1	0.20		
Contact Pad to Center Pad (X64)	G2	1.95		
Thermal Via Diameter	V		0.33	
Thermal Via Pitch	EV		1.20	

**Notes:**

1. Dimensioning and tolerancing per ASME Y14.5M  
BSC: Basic Dimension. Theoretically exact value shown without tolerances.
2. For best soldering results, thermal vias, if used, should be filled or tented to avoid solder loss during reflow process

**Package Outlines and Dimensions**

**64-Lead Plastic Quad Flatpack (PT) - 10x10x1.0 mm Body [TQFP]  
With 6.0x6.0 mm Exposed Pad**

**Note:** For the most current package drawings, please see the Microchip Packaging Specification located at <http://www.microchip.com/packaging>

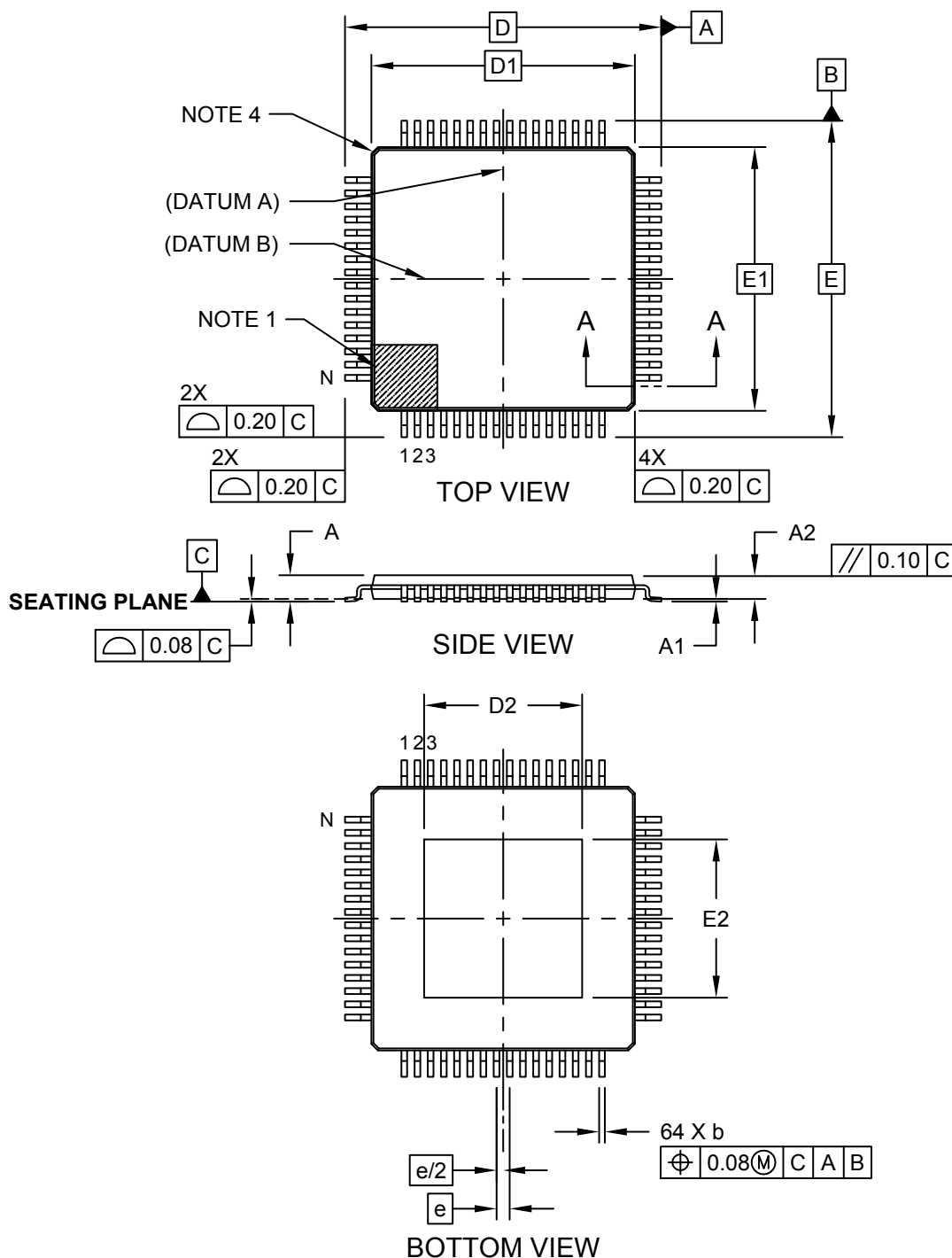

---



---

## Package Outlines and Dimensions

---



---

### 64-Lead Plastic Quad Flatpack (PT) - 10x10x1.0 mm Body [TQFP] With 6.0x6.0 mm Exposed Pad

**Note:** For the most current package drawings, please see the Microchip Packaging Specification located at <http://www.microchip.com/packaging>

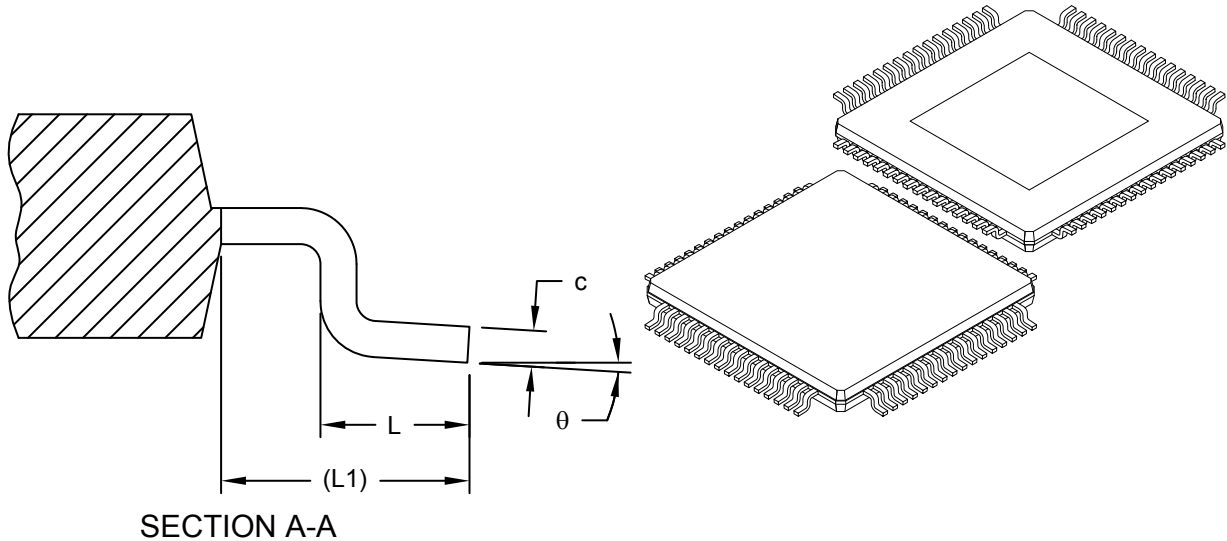

Dimension Limits	Units	MILLIMETERS		
		MIN	NOM	MAX
Number of Pins	N	64		
Pitch	e	0.50 BSC		
Overall Height	A	0.80	0.90	1.20
Standoff	A1	0.05	-	0.15
Molded Package Thickness	A2	0.95	1.00	1.05
Overall Width	E	12.00 BSC		
Molded Package Width	E1	10.00 BSC		
Exposed Pad Width	E2	5.90	6.00	6.10
Overall Length	D	12.00 BSC		
Molded Package Length	D1	10.00 BSC		
Exposed Pad Length	D2	5.90	6.00	6.10
Terminal Width	b	0.17	0.22	0.27
Terminal Thickness	c	0.09	-	0.20
Terminal Length	L	0.45	0.60	0.75
Footprint	(L1)	1.00 REF		
Foot Angle	$\theta$	0°	3.5°	7°

**Notes:**

1. Pin 1 visual index feature may vary, but must be located within the hatched area.
2. Exact shape of each corner is optional.
3. Dimensioning and tolerancing per ASME Y14.5M

BSC: Basic Dimension. Theoretically exact value shown without tolerances.

REF: Reference Dimension, usually without tolerance, for information purposes only.

**Footprint Outlines and Dimensions**

**64-Lead Plastic Quad Flatpack (PT) - 10x10x1.0 mm Body [TQFP]  
With 6.0x6.0 mm Exposed Pad**

**Note:** For the most current package drawings, please see the Microchip Packaging Specification located at <http://www.microchip.com/packaging>

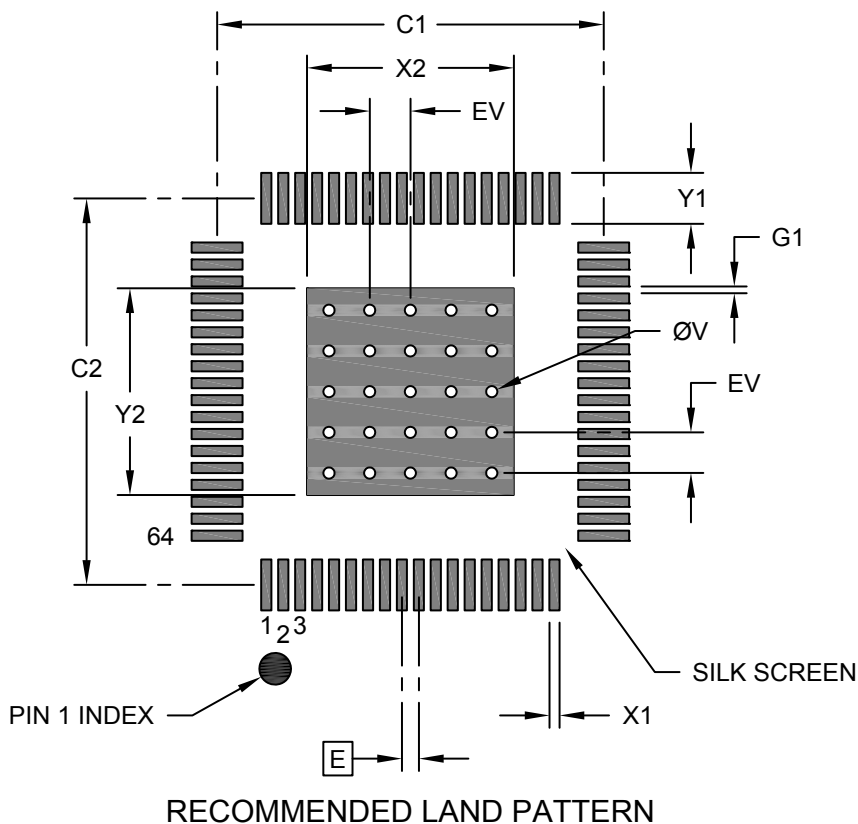

Dimension Limits	Units	MILLIMETERS		
		MIN	NOM	MAX
Contact Pitch	E	0.50 BSC		
Optional Center Pad Width	X2			6.10
Optional Center Pad Length	Y2			6.10
Contact Pad Spacing	C1		11.40	
Contact Pad Spacing	C2		11.40	
Contact Pad Width (X64)	X1			0.30
Contact Pad Length (X64)	Y1			1.50
Contact Pad to Contact Pad (X60)	G1	0.20		
Thermal Via Diameter	V		0.33	
Thermal Via Pitch	EV		1.20	

**Notes:**

- Dimensioning and tolerancing per ASME Y14.5M  
BSC: Basic Dimension. Theoretically exact value shown without tolerances.
- For best soldering results, thermal vias, if used, should be filled or tented to avoid solder loss during reflow process

---



---

## Package Outlines and Dimensions

---



---

### 80-Lead Plastic Thin Quad Flatpack (PF) – 14x14x1 mm Body, 2.00 mm [TQFP]

**Note:** For the most current package drawings, please see the Microchip Packaging Specification located at <http://www.microchip.com/packaging>

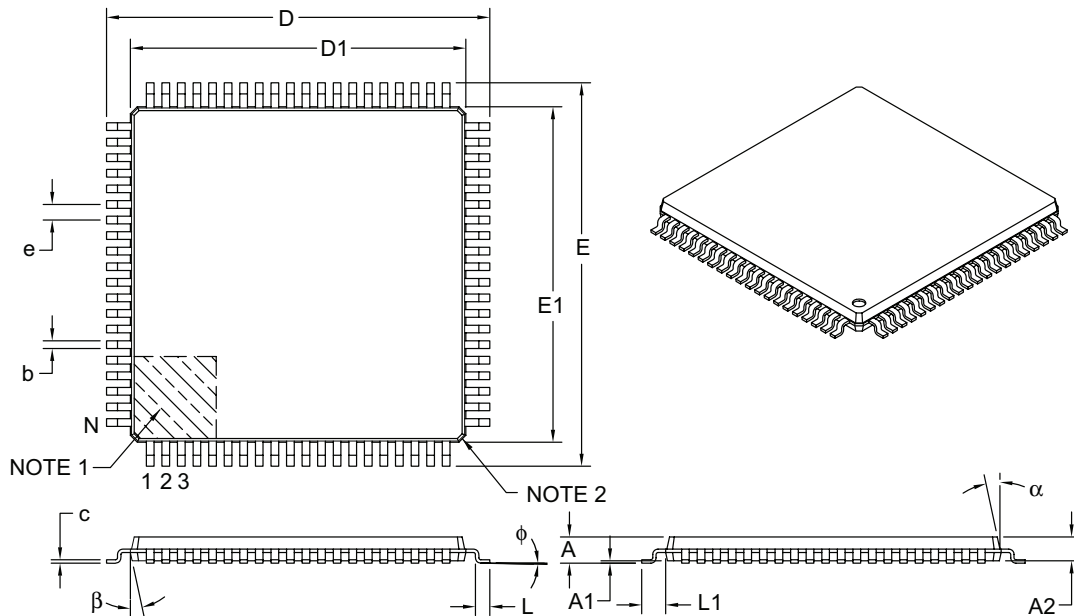

Dimension Limits	Units	MILLIMETERS		
		MIN	NOM	MAX
Number of Leads	N	80		
Lead Pitch	e	0.65 BSC		
Overall Height	A	–	–	1.20
Molded Package Thickness	A2	0.95	1.00	1.05
Standoff	A1	0.05	–	0.15
Foot Length	L	0.45	0.60	0.75
Footprint	L1	1.00 REF		
Foot Angle	φ	0°	3.5°	7°
Overall Width	E	16.00 BSC		
Overall Length	D	16.00 BSC		
Molded Package Width	E1	14.00 BSC		
Molded Package Length	D1	14.00 BSC		
Lead Thickness	c	0.09	–	0.20
Lead Width	b	0.22	0.32	0.38
Mold Draft Angle Top	α	11°	12°	13°
Mold Draft Angle Bottom	β	11°	12°	13°

**Notes:**

- Pin 1 visual index feature may vary, but must be located within the hatched area.
- Chamfers at corners are optional; size may vary.
- Dimensions D1 and E1 do not include mold flash or protrusions. Mold flash or protrusions shall not exceed 0.25 mm per side.
- Dimensioning and tolerancing per ASME Y14.5M.

BSC: Basic Dimension. Theoretically exact value shown without tolerances.

REF: Reference Dimension, usually without tolerance, for information purposes only.

Microchip Technology Drawing C04-116B

**Footprint Outlines and Dimensions**

80-Lead Plastic Thin Quad Flatpack (PF) 14x14x1mm Body, 2.00 mm Footprint [TQFP]

**Note:** For the most current package drawings, please see the Microchip Packaging Specification located at <http://www.microchip.com/packaging>

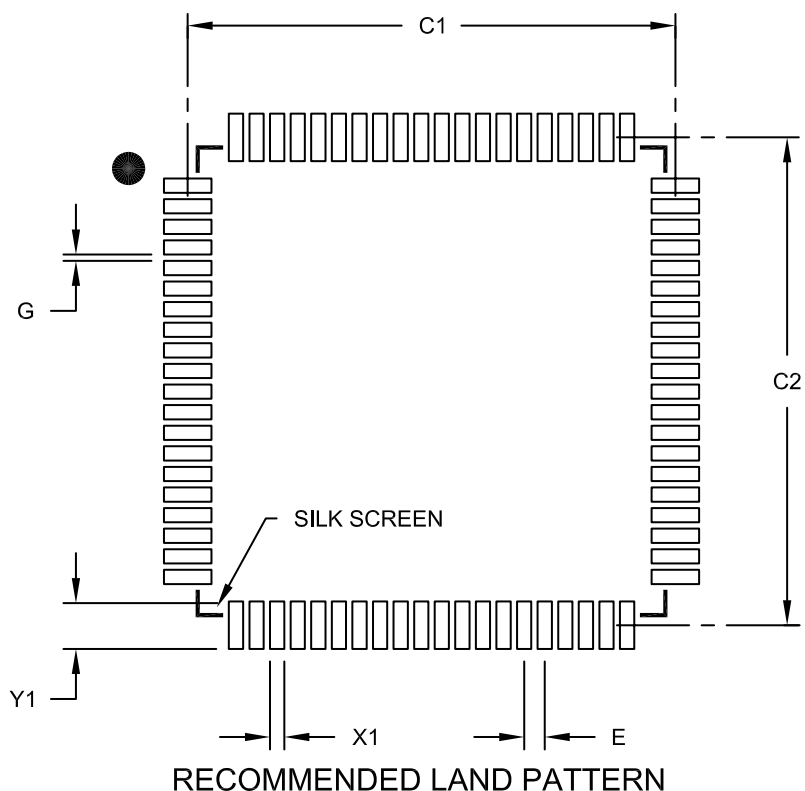

Dimension Limits	Units	MILLIMETERS		
		MIN	NOM	MAX
Contact Pitch	E	0.65 BSC		
Contact Pad Spacing	C1		15.40	
Contact Pad Spacing	C2		15.40	
Contact Pad Width (X80)	X1			0.45
Contact Pad Length (X80)	Y1			1.50
Distance Between Pads	G	0.20		

Notes:

1. Dimensioning and tolerancing per ASME Y14.5M

BSC: Basic Dimension. Theoretically exact value shown without tolerances.

Microchip Technology Drawing No. C04-2116C



---



---

## Package Outlines and Dimensions

---



---

### 80-Lead Plastic Thin Quad Flatpack (PT) – 12x12x1 mm Body, 2.00 mm [TQFP]

**Note:** For the most current package drawings, please see the Microchip Packaging Specification located at <http://www.microchip.com/packaging>

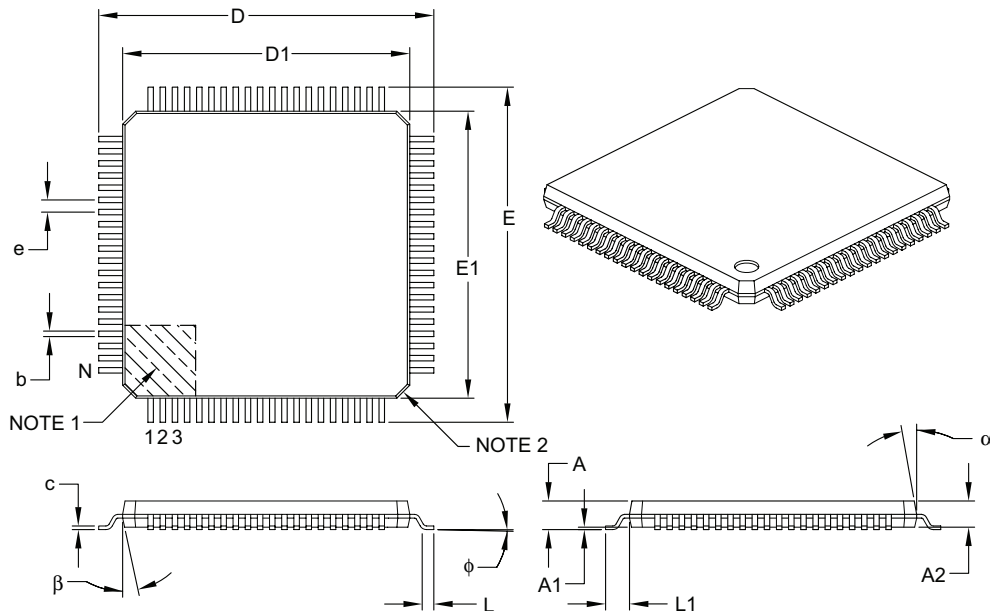

Dimension Limits	Units	MILLIMETERS		
		MIN	NOM	MAX
Number of Leads	N	80		
Lead Pitch	e	0.50 BSC		
Overall Height	A	–	–	1.20
Molded Package Thickness	A2	0.95	1.00	1.05
Standoff	A1	0.05	–	0.15
Foot Length	L	0.45	0.60	0.75
Footprint	L1	1.00 REF		
Foot Angle	φ	0°	3.5°	7°
Overall Width	E	14.00 BSC		
Overall Length	D	14.00 BSC		
Molded Package Width	E1	12.00 BSC		
Molded Package Length	D1	12.00 BSC		
Lead Thickness	c	0.09	–	0.20
Lead Width	b	0.17	0.22	0.27
Mold Draft Angle Top	α	11°	12°	13°
Mold Draft Angle Bottom	β	11°	12°	13°

**Notes:**

- Pin 1 visual index feature may vary, but must be located within the hatched area.
- Chamfers at corners are optional; size may vary.
- Dimensions D1 and E1 do not include mold flash or protrusions. Mold flash or protrusions shall not exceed 0.25 mm per side.
- Dimensioning and tolerancing per ASME Y14.5M.

BSC: Basic Dimension. Theoretically exact value shown without tolerances.

REF: Reference Dimension, usually without tolerance, for information purposes only.

Microchip Technology Drawing C04-092B

**Footprint Outlines and Dimensions**

80-Lead Plastic Thin Quad Flatpack (PT)-12x12x1mm Body, 2.00 mm Footprint [TQFP]

**Note:** For the most current package drawings, please see the Microchip Packaging Specification located at <http://www.microchip.com/packaging>

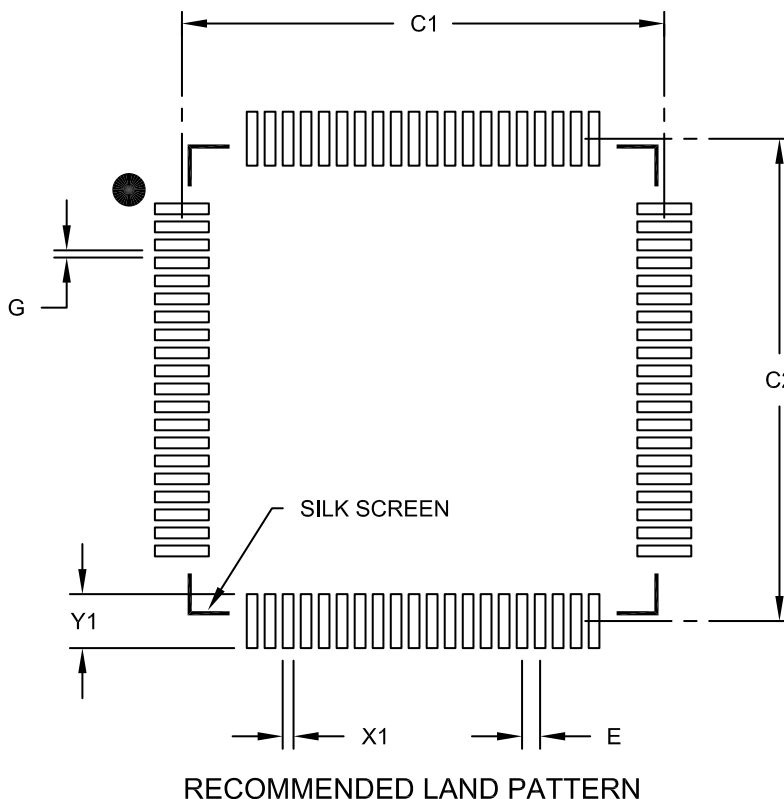

		Units	MILLIMETERS		
Dimension Limits			MIN	NOM	MAX
Contact Pitch	E	0.50 BSC			
Contact Pad Spacing	C1			13.40	
Contact Pad Spacing	C2			13.40	
Contact Pad Width (X80)	X1				0.30
Contact Pad Length (X80)	Y1				1.50
Distance Between Pads	G	0.20			

Notes:

1. Dimensioning and tolerancing per ASME Y14.5M

BSC: Basic Dimension. Theoretically exact value shown without tolerances.

Microchip Technology Drawing No. C04-2092B

## Package Outlines and Dimensions

### 100-Lead Plastic Thin Quad Flatpack (PF) – 14x14x1 mm Body, 2.00 mm [TQFP]

**Note:** For the most current package drawings, please see the Microchip Packaging Specification located at <http://www.microchip.com/packaging>

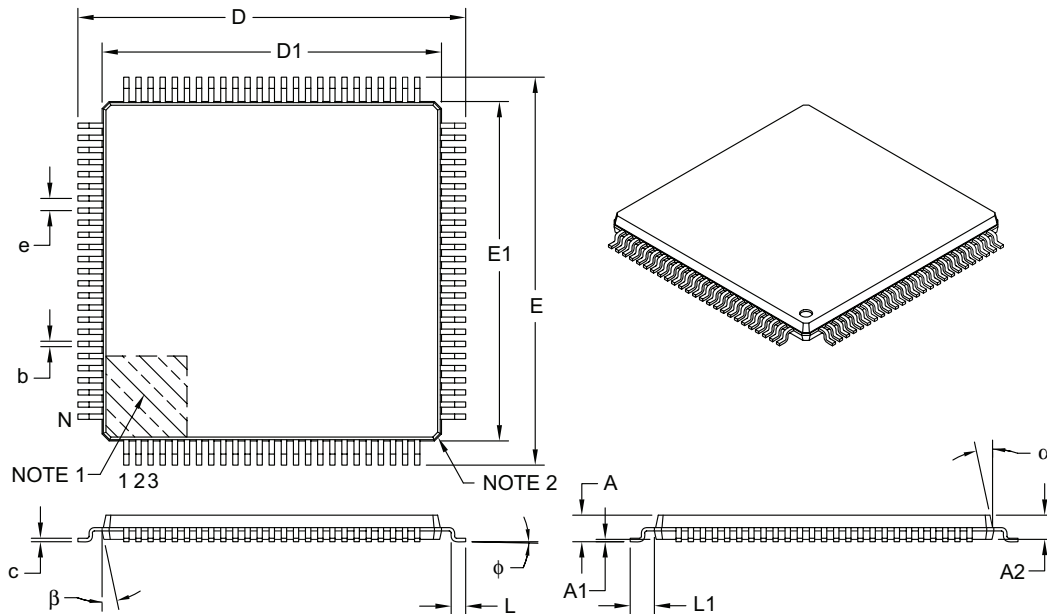

Dimension Limits	Units	MILLIMETERS		
		MIN	NOM	MAX
Number of Leads	N	100		
Lead Pitch	e	0.50 BSC		
Overall Height	A	–	–	1.20
Molded Package Thickness	A2	0.95	1.00	1.05
Standoff	A1	0.05	–	0.15
Foot Length	L	0.45	0.60	0.75
Footprint	L1	1.00 REF		
Foot Angle	φ	0°	3.5°	7°
Overall Width	E	16.00 BSC		
Overall Length	D	16.00 BSC		
Molded Package Width	E1	14.00 BSC		
Molded Package Length	D1	14.00 BSC		
Lead Thickness	c	0.09	–	0.20
Lead Width	b	0.17	0.22	0.27
Mold Draft Angle Top	α	11°	12°	13°
Mold Draft Angle Bottom	β	11°	12°	13°

**Notes:**

- Pin 1 visual index feature may vary, but must be located within the hatched area.
- Chamfers at corners are optional; size may vary.
- Dimensions D1 and E1 do not include mold flash or protrusions. Mold flash or protrusions shall not exceed 0.25 mm per side.
- Dimensioning and tolerancing per ASME Y14.5M.

BSC: Basic Dimension. Theoretically exact value shown without tolerances.

REF: Reference Dimension, usually without tolerance, for information purposes only.

Microchip Technology Drawing C04-110B

**Footprint Outlines and Dimensions**

100-Lead Plastic Thin Quad Flatpack (PF) - 14x14x1 mm Body 2.00 mm Footprint [TQFP]

**Note:** For the most current package drawings, please see the Microchip Packaging Specification located at <http://www.microchip.com/packaging>

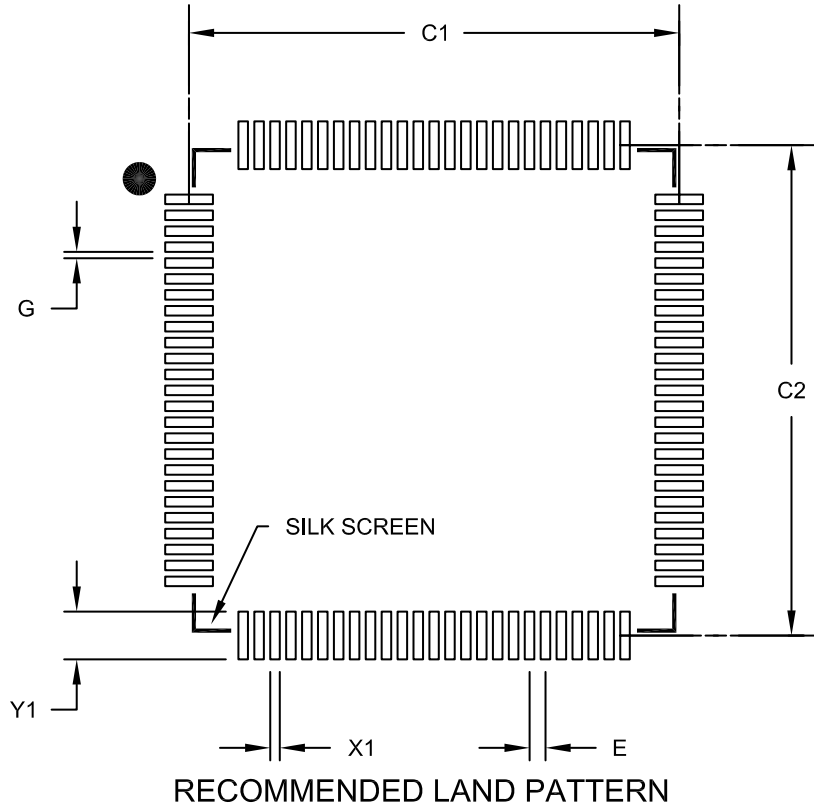

Dimension Limits	Units	MILLIMETERS		
		MIN	NOM	MAX
Contact Pitch	E	0.50 BSC		
Contact Pad Spacing	C1		15.40	
Contact Pad Spacing	C2		15.40	
Contact Pad Width (X100)	X1			0.30
Contact Pad Length (X100)	Y1			1.50
Distance Between Pads	G	0.20		

Notes:

1. Dimensioning and tolerancing per ASME Y14.5M

BSC: Basic Dimension. Theoretically exact value shown without tolerances.

Microchip Technology Drawing No. C04-2110B

---



---

## Package Outlines and Dimensions

---



---

### 100-Lead Plastic Thin Quad Flatpack (PT) – 12x12x1 mm Body, 2.00 mm [TQFP]

**Note:** For the most current package drawings, please see the Microchip Packaging Specification located at <http://www.microchip.com/packaging>

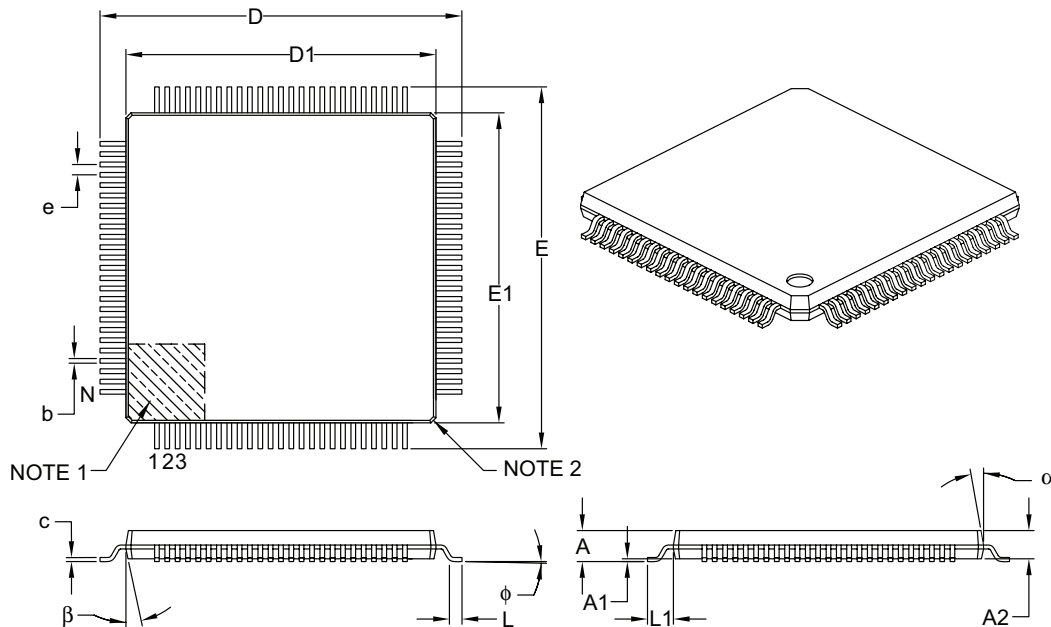

Dimension Limits	Units	MILLIMETERS		
		MIN	NOM	MAX
Number of Leads	N	100		
Lead Pitch	e	0.40 BSC		
Overall Height	A	–	–	1.20
Molded Package Thickness	A2	0.95	1.00	1.05
Standoff	A1	0.05	–	0.15
Foot Length	L	0.45	0.60	0.75
Footprint	L1	1.00 REF		
Foot Angle	$\phi$	0°	3.5°	7°
Overall Width	E	14.00 BSC		
Overall Length	D	14.00 BSC		
Molded Package Width	E1	12.00 BSC		
Molded Package Length	D1	12.00 BSC		
Lead Thickness	c	0.09	–	0.20
Lead Width	b	0.13	0.18	0.23
Mold Draft Angle Top	$\alpha$	11°	12°	13°
Mold Draft Angle Bottom	$\beta$	11°	12°	13°

**Notes:**

- Pin 1 visual index feature may vary, but must be located within the hatched area.
- Chamfers at corners are optional; size may vary.
- Dimensions D1 and E1 do not include mold flash or protrusions. Mold flash or protrusions shall not exceed 0.25 mm per side.
- Dimensioning and tolerancing per ASME Y14.5M.

BSC: Basic Dimension. Theoretically exact value shown without tolerances.

REF: Reference Dimension, usually without tolerance, for information purposes only.

Microchip Technology Drawing C04-100B

**Footprint Outlines and Dimensions**

100-Lead Plastic Thin Quad Flatpack (PT)-12x12x1mm Body, 2.00 mm Footprint [TQFP]

**Note:** For the most current package drawings, please see the Microchip Packaging Specification located at <http://www.microchip.com/packaging>

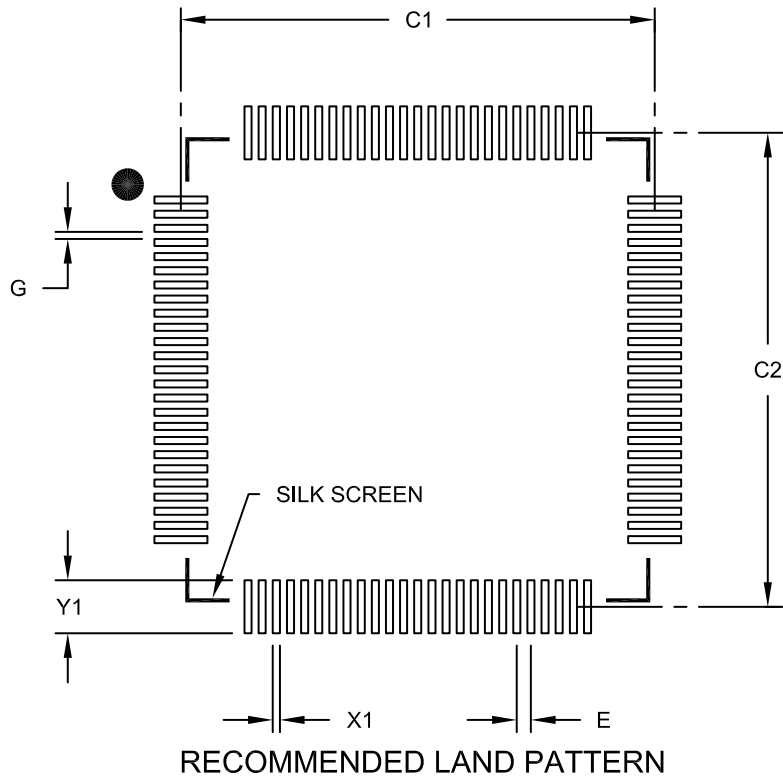

Dimension Limits	Units	MILLIMETERS		
		MIN	NOM	MAX
Contact Pitch	E	0.40 BSC		
Contact Pad Spacing	C1		13.40	
Contact Pad Spacing	C2		13.40	
Contact Pad Width (X100)	X1			0.20
Contact Pad Length (X100)	Y1			1.50
Distance Between Pads	G	0.20		

Notes:

1. Dimensioning and tolerancing per ASME Y14.5M

BSC: Basic Dimension. Theoretically exact value shown without tolerances.

Microchip Technology Drawing No. C04-2100B

**Package Outlines and Dimensions**

**128-Lead Plastic Quad Flat, No Lead Package (Z7) - 14x14x1.0 mm Body [TQFP]  
With 5.0x5.0 mm Exposed Pad**

**Note:** For the most current package drawings, please see the Microchip Packaging Specification located at <http://www.microchip.com/packaging>

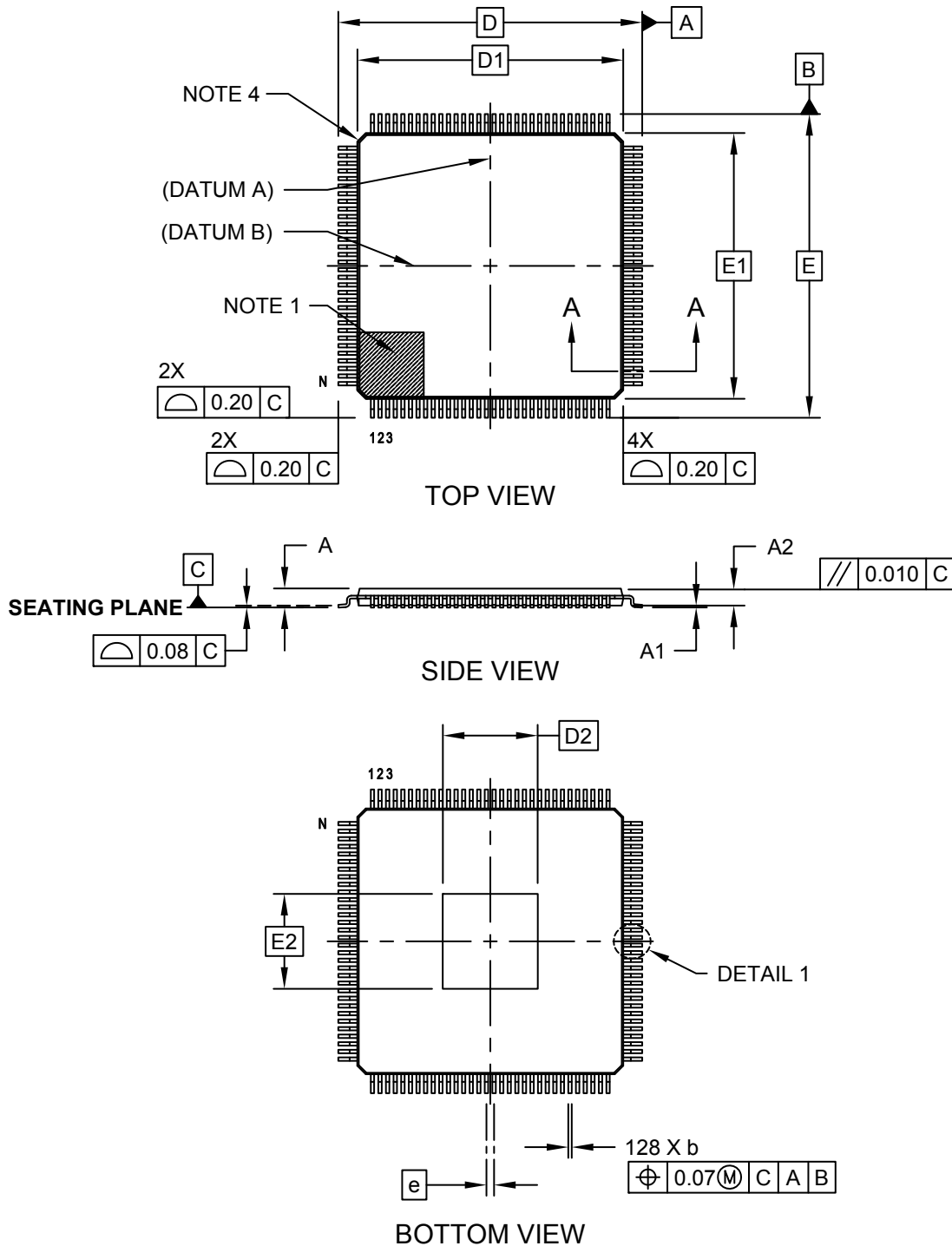

**Package Outlines and Dimensions**

**128-Lead Plastic Quad Flat, No Lead Package (Z7) - 14x14x1.0 mm Body [TQFP]  
With 5.0x5.0 mm Exposed Pad**

**Note:** For the most current package drawings, please see the Microchip Packaging Specification located at <http://www.microchip.com/packaging>

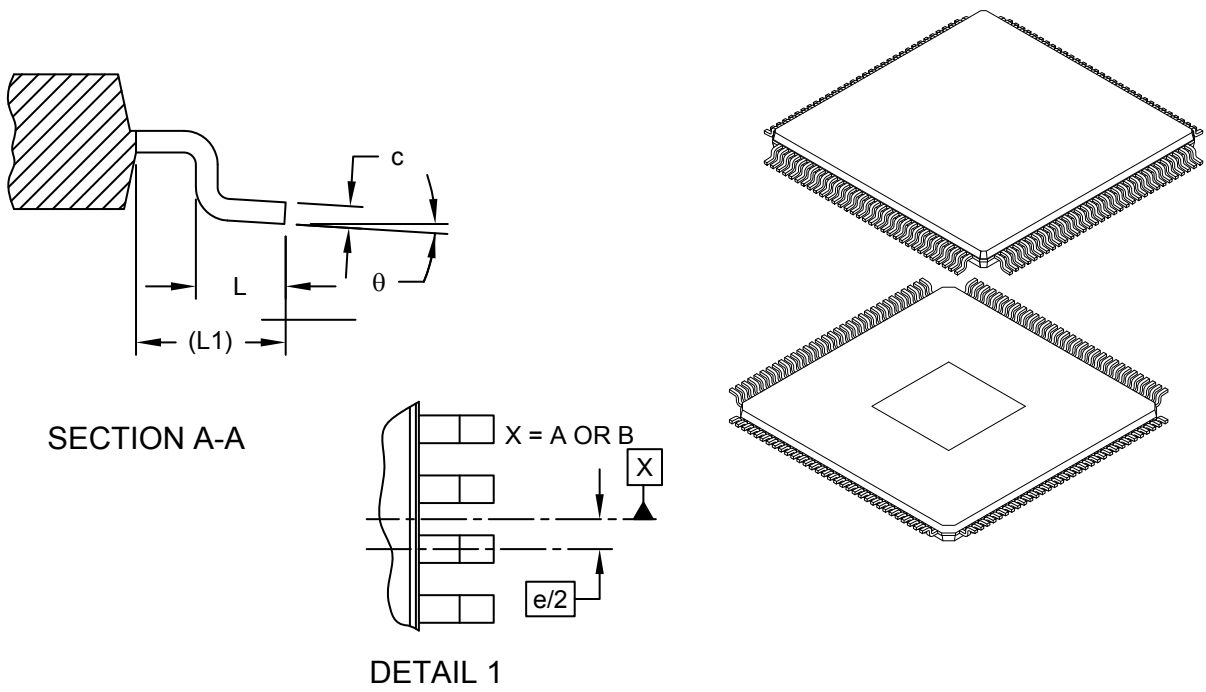

Dimension Limits	Units	MILLIMETERS		
		MIN	NOM	MAX
Number of Pins	N	128		
Pitch	e	0.40 BSC		
Overall Height	A	0.80	0.90	1.20
Standoff	A1	0.05	-	0.15
Terminal Thickness	A2	0.95	1.00	1.05
Overall Width	E	16.00 BSC		
Molded Package Width	E1	14.00 BSC		
Exposed Pad Width	E2	4.90	5.00	5.10
Overall Length	D	16.00 BSC		
Molded Package Length	D1	14.00 BSC		
Exposed Pad Length	D2	4.90	5.00	5.10
Terminal Width	b	0.13	0.18	0.23
Terminal Thickness	c	0.09	-	0.20
Terminal Length	L	0.45	0.60	0.75
Footprint	(L1)	1.00 REF		
Foot Angle	θ	0°	3.5°	7°

**Notes:**

1. Pin 1 visual index feature may vary, but must be located within the hatched area.
2. Dimensioning and tolerancing per ASME Y14.5M  
     BSC: Basic Dimension. Theoretically exact value shown without tolerances.  
     REF: Reference Dimension, usually without tolerance, for information purposes only.
3. Exact shape of each corner is optional.



**Package Outlines and Dimensions**

**128-Lead Thin Quad Flatpack (6XX) - 10x10x1.0 mm Body [TQFP]  
With 10x10 mm Exposed Pad**

**Note:** For the most current package drawings, please see the Microchip Packaging Specification located at <http://www.microchip.com/packaging>

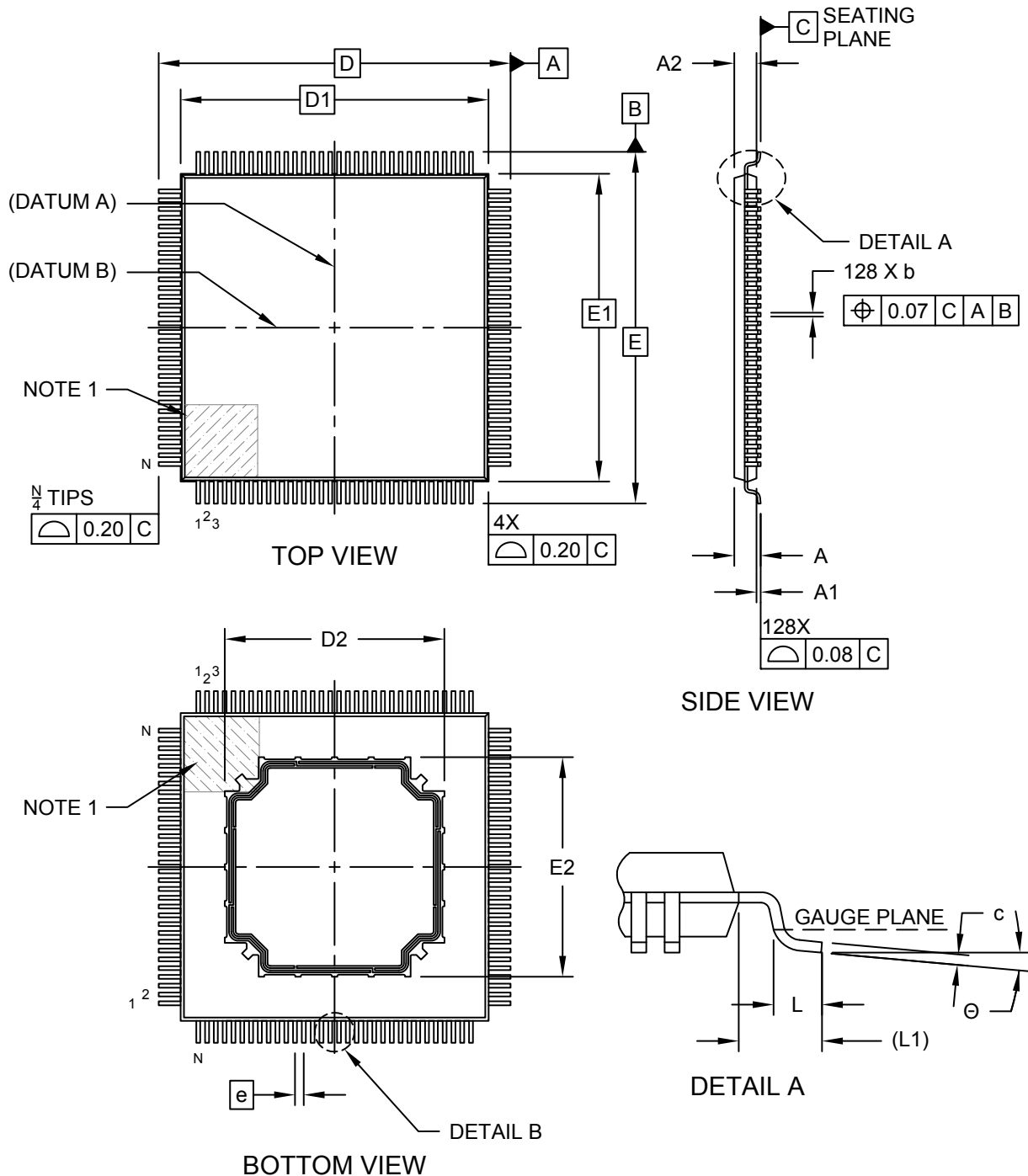

**Package Outlines and Dimensions**

**128-Lead Thin Quad Flatpack (6XX) - 10x10x1.0 mm Body [TQFP]  
With 10x10 mm Exposed Pad**

**Note:** For the most current package drawings, please see the Microchip Packaging Specification located at <http://www.microchip.com/packaging>

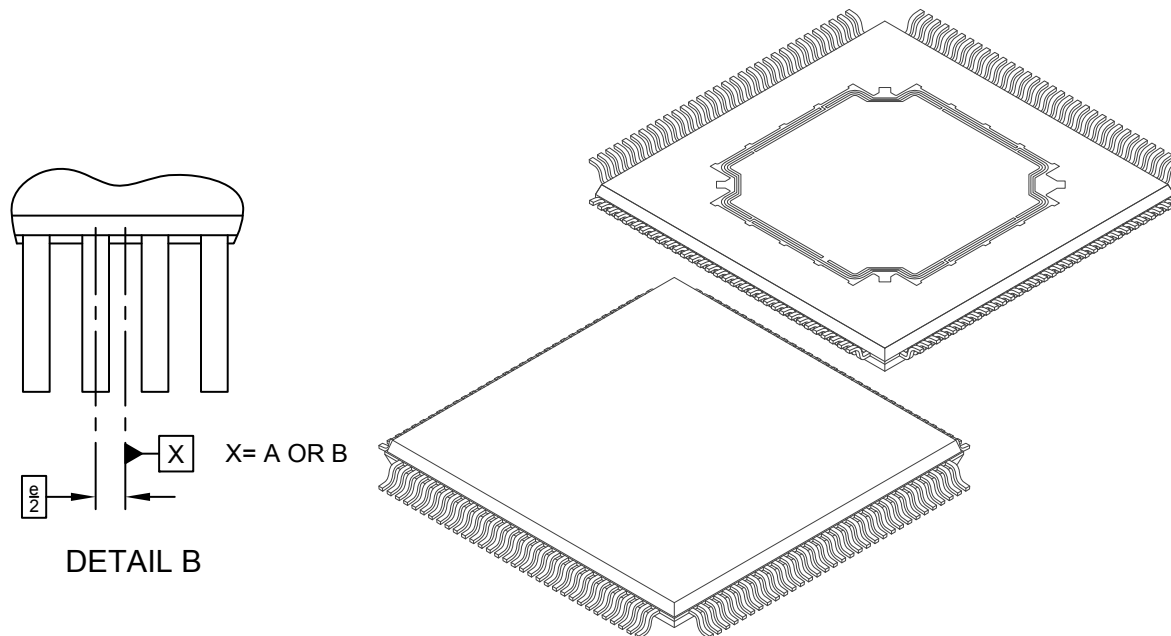

Dimension Limits	Units	MILLIMETERS		
		MIN	NOM	MAX
Number of Terminals	N	128		
Pitch	e	0.40 BSC		
Overall Height	A	-	-	1.20
Standoff	A1	0.05	-	0.15
Molded Package Thickness	A3	0.05	-	0.15
Overall Length	D	16.00 BSC		
Molded Package Length	D1	14.00 BSC		
Exposed Pad Length	D2	9.85	10.00	10.15
Overall Width	E	14.00 BSC		
Molded Package Width	E1	14.00 BSC		
Exposed Pad Width	E2	9.85	10.00	10.15
Terminal Width	b	0.13	0.18	0.23
Terminal Length	L	0.45	0.60	0.75
Footprint	(L1)	1.00 REF		
Footprint Angle	Θ	0°	-	7°

**Notes:**

- Pin 1 visual index feature may vary, but must be located within the hatched area.
- Dimensioning and tolerancing per ASME Y14.5M
  - BSC: Basic Dimension. Theoretically exact value shown without tolerances.
  - REF: Reference Dimension, usually without tolerance, for information purposes only.

---



---

## Footprint Outlines and Dimensions

---



---

### 128-Lead Thin Quad Flatpack (6XX) - 10x10x1.0 mm Body [TQFP] With 10x10 mm Exposed Pad

**Note:** For the most current package drawings, please see the Microchip Packaging Specification located at <http://www.microchip.com/packaging>

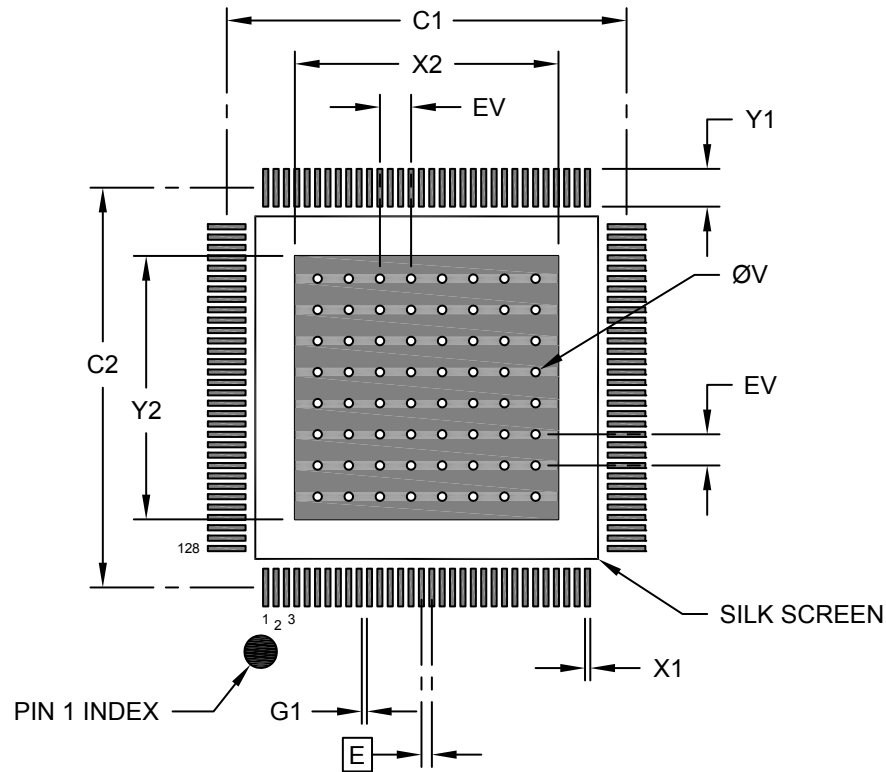

#### RECOMMENDED LAND PATTERN

Dimension	Units	MILLIMETERS		
		MIN	NOM	MAX
Contact Pitch	E	0.40 BSC		
Center Pad Width	X2			10.50
Center Pad Length	Y2			10.50
Contact Pad Spacing	C1		15.40	
Contact Pad Spacing	C2		15.40	
Contact Pad Width (X128)	X1			0.20
Contact Pad Length (X128)	Y1			1.54
Contact Pad to Contact Pad (X124)	G1	0.20		
Thermal Via Diameter	V		0.33	
Thermal Via Pitch	EV		1.20	

**Notes:**

1. Dimensioning and tolerancing per ASME Y14.5M  
BSC: Basic Dimension. Theoretically exact value shown without tolerances.
2. For best soldering results, thermal vias, if used, should be filled or tented to avoid solder loss during reflow process

**Package Outlines and Dimensions**

**144-Lead Plastic Thin Quad Flatpack (PH)-16x16x1mm Body, 2.00 mm Footprint [TQFP]**

**Note:** For the most current package drawings, please see the Microchip Packaging Specification located at <http://www.microchip.com/packaging>

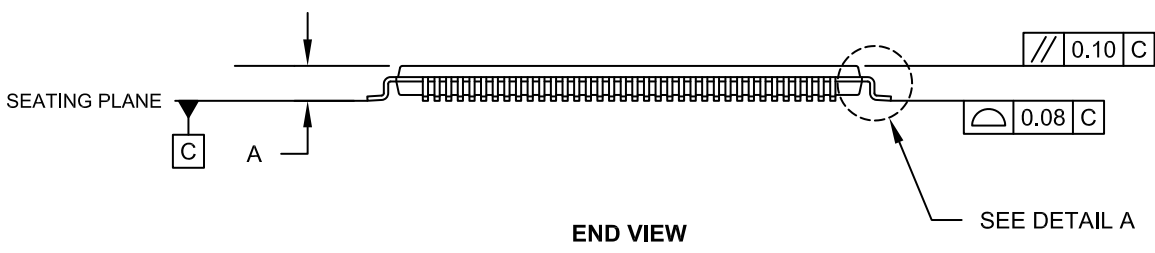
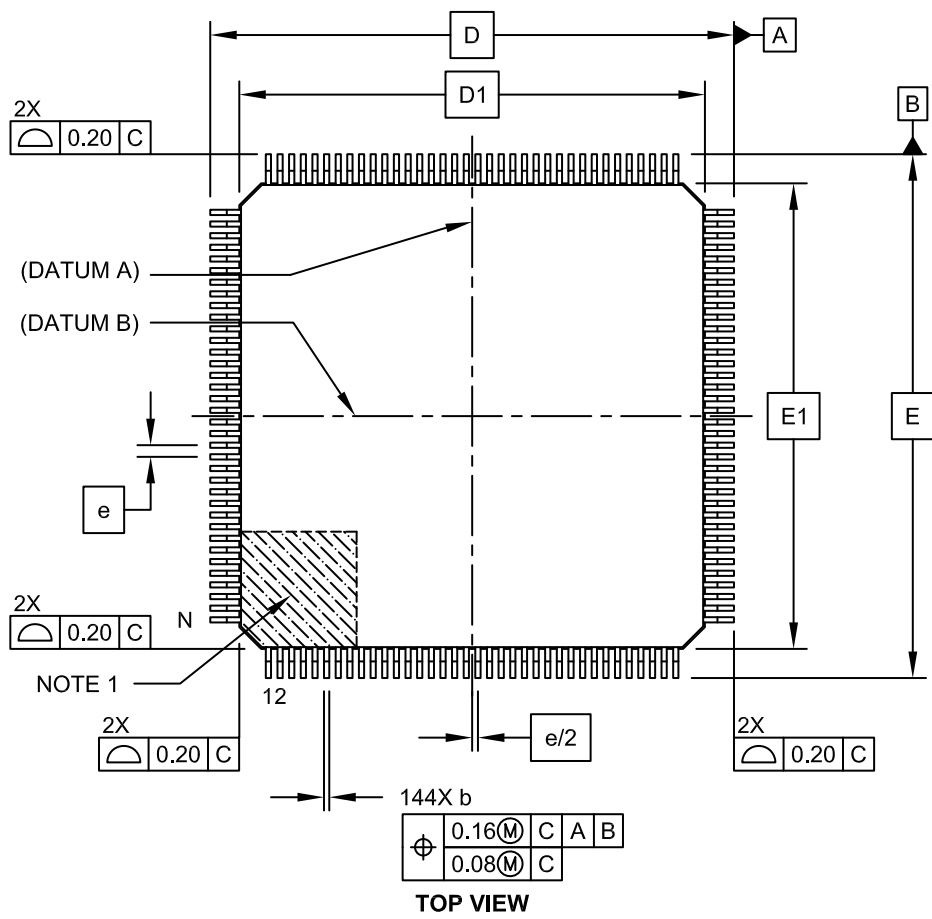

---



---

## Package Outlines and Dimensions

---



---

### 144-Lead Plastic Thin Quad Flatpack (PH)-16x16x1mm Body, 2.00 mm Footprint [TQFP]

**Note:** For the most current package drawings, please see the Microchip Packaging Specification located at <http://www.microchip.com/packaging>

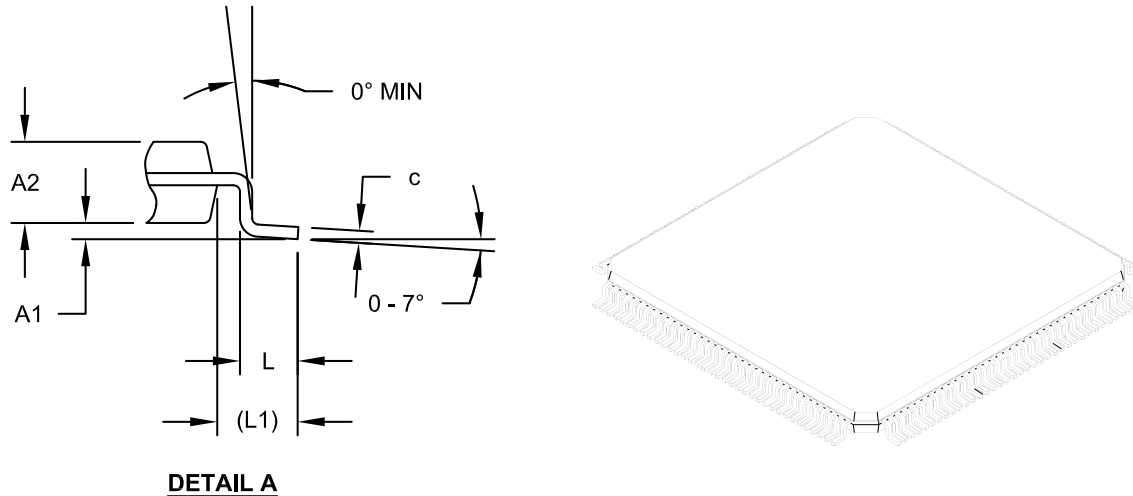

Dimension Limits	Units	MILLIMETERS		
		MIN	NOM	MAX
Number of Pins	N	144		
Lead Pitch	e	0.40 BSC		
Overall Height	A	-	-	1.20
Molded Package Thickness	A2	0.95	1.00	1.05
Standoff	A1	0.05	-	0.15
Foot Length	L	0.45	0.60	0.75
Footprint	L1	1.00 REF		
Overall Width	D	18.00 BSC		
Overall Length	E	18.00 BSC		
Molded Body Width	D1	16.00 BSC		
Molded Body Length	E1	16.00 BSC		
Lead Thickness	c	0.09	-	0.20
Lead Width	b	0.13	-	0.23

**Notes:**

1. Pin 1 visual index feature may vary, but must be located within the hatched area.
2. Package is saw singulated.
3. Dimensioning and tolerancing per ASME Y14.5M.
  - BSC: Basic Dimension. Theoretically exact value shown without tolerances.
  - REF: Reference Dimension, usually without tolerance, for information purposes only.

**Footprint Outlines and Dimensions**

144-Lead Plastic Thin Quad Flat Pack (PH) - 16x16 mm Body, 2.00 mm Footprint [TQFP]

**Note:** For the most current package drawings, please see the Microchip Packaging Specification located at <http://www.microchip.com/packaging>

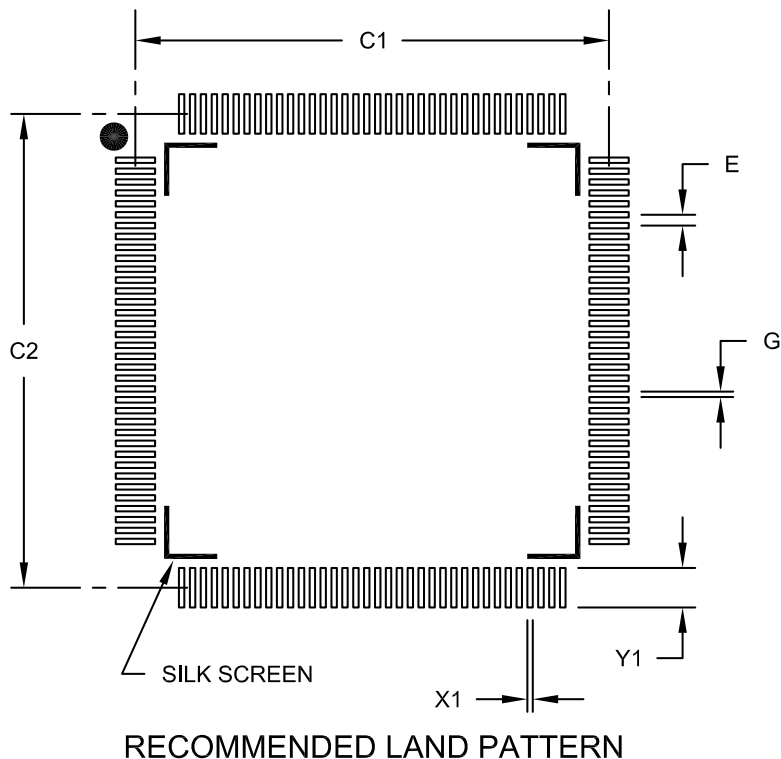

Dimension Limits	Units	MILLIMETERS		
		MIN	NOM	MAX
Contact Pitch	E	0.40 BSC		
Contact Pad Spacing	C1		17.40	
Contact Pad Spacing	C2		17.40	
Contact Pad Width (X144)	X1			0.20
Contact Pad Length (X144)	Y1			1.45
Distance Between Pads	G	0.20		

Notes:

1. Dimensioning and tolerancing per ASME Y14.5M

BSC: Basic Dimension. Theoretically exact value shown without tolerances.

---

---

**Package Outlines and Dimensions**

---

---

**(WL)CSP**

**Package Outlines and Dimensions**

**4-Lead Chip Scale Package (CS) - [CSP]**

**Note:** For the most current package drawings, please see the Microchip Packaging Specification located at <http://www.microchip.com/packaging>

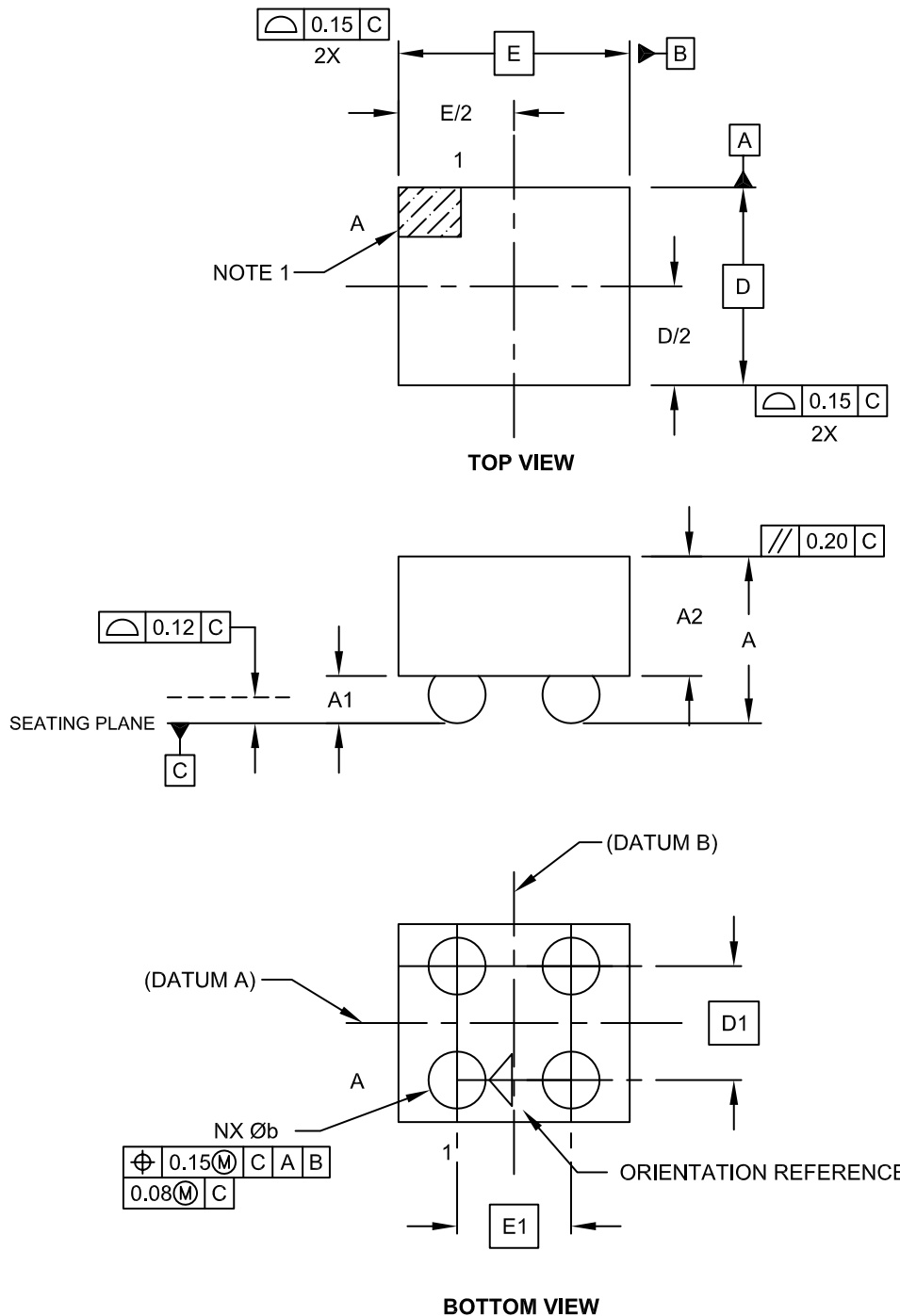



---



---

## Package Outlines and Dimensions

---



---

### 4-Lead Chip Scale Package (CS) - [CSP]

**Note:** For the most current package drawings, please see the Microchip Packaging Specification located at <http://www.microchip.com/packaging>

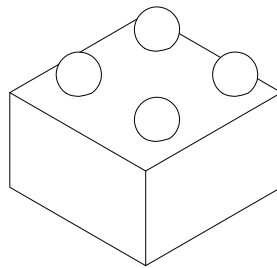

Units		MILLIMETERS		
Dimension Limits		MIN	NOM	MAX
Number of Contacts	N		4	
Adjacent Column X-Pitch	E1	0.400 BSC		
Adjacent Row Y-Pitch	D1	0.400 BSC		
Overall Height	A	0.47	0.51	0.55
Die Height	A2	0.33	0.35	0.37
Bump Height	A1	0.14	0.16	0.18
Overall Length	E	NOTE 4		
Overall Width	D	NOTE 4		
Ball Diameter	b	0.18	0.200	0.22

**Notes:**

1. Orientation reference feature may vary, but must be located within the hatched area.
2. Package is saw singulated.
3. Dimensioning and tolerancing per ASME Y14.5M.  
 BSC: Basic Dimension. Theoretically exact value shown without tolerances.  
 REF: Reference Dimension, usually without tolerance, for information purposes only.
4. Package size varies with specific devices. Please contact our local Microchip representative for specific details.

Microchip Technology Drawing C04-6005D Sheet 2 of 2

**Footprint Outlines and Dimensions**

**4-Lead Chip Scale Package (CS) - [CSP]**

**Note:** For the most current package drawings, please see the Microchip Packaging Specification located at <http://www.microchip.com/packaging>

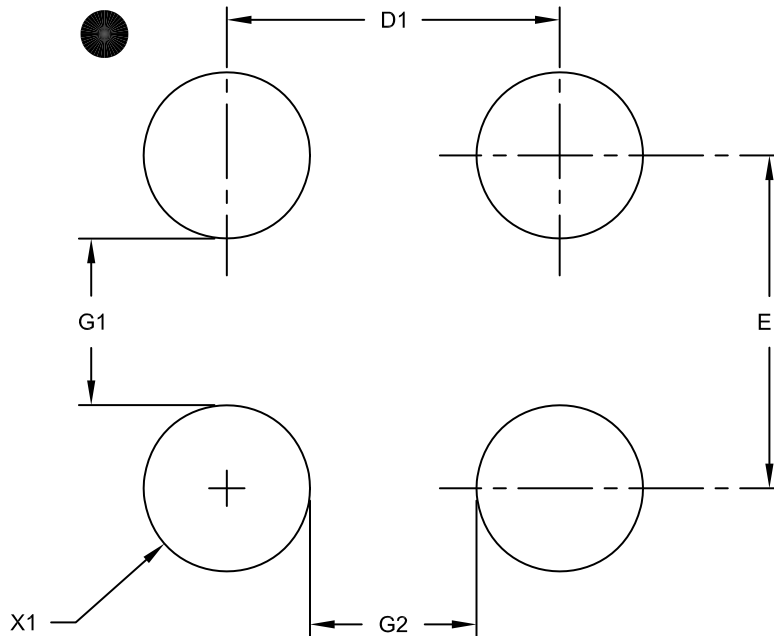

**RECOMMENDED LAND PATTERN**

		MILLIMETERS		
Units		MIN	NOM	MAX
Dimension Limits				
Number of Contacts	N	4		
Contact Pad Spacing	E1		0.40	
Contact Pad Spacing	D1		0.40	
Contact Pad Diameter (X4)	X1			0.20
Distance Between Pads	G1	0.24		
Distance Between Pads	G2	0.24		

**Notes:**

1. Dimensioning and tolerancing per ASME Y14.5M

BSC: Basic Dimension. Theoretically exact value shown without tolerances.

Microchip Technology Drawing No. C04-8005A

**Package Outlines and Dimensions**

**4-Lead Chip Scale Package (CS) - [CSP]**

**Note:** For the most current package drawings, please see the Microchip Packaging Specification located at <http://www.microchip.com/packaging>

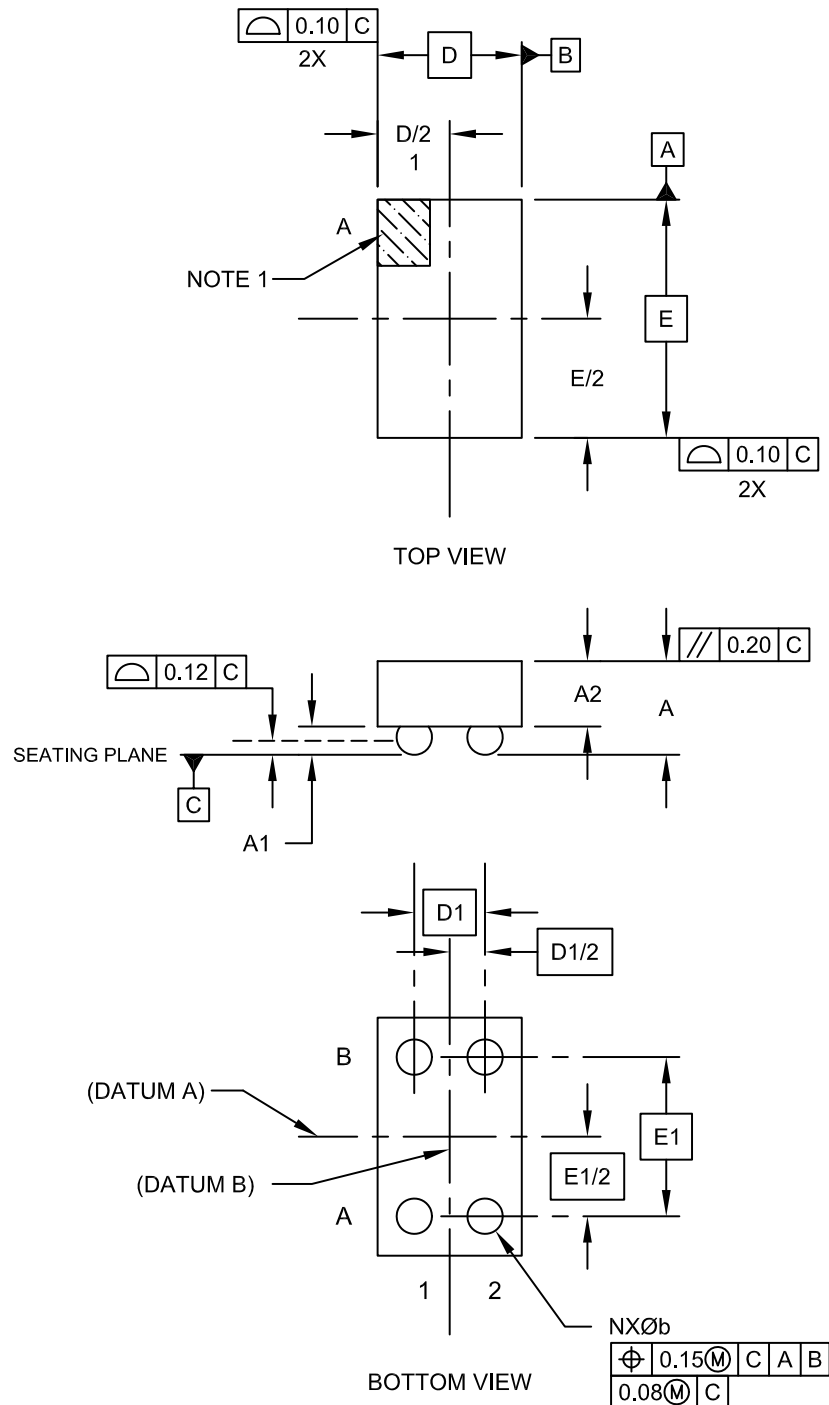

---



---

## Package Outlines and Dimensions

---



---

### 4-Lead Chip Scale Package (CS) - [CSP]

**Note:** For the most current package drawings, please see the Microchip Packaging Specification located at <http://www.microchip.com/packaging>

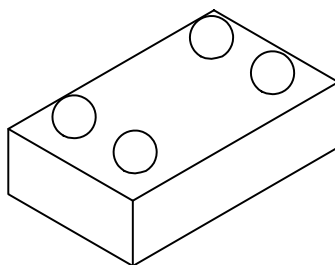

		Units	MILLIMETERS		
Dimension Limits			MIN	NOM	MAX
Number of Contacts	N			4	
Adjacent Column X-Pitch	D1		0.400 BSC		
Adjacent Row Y-Pitch	E1		0.900 BSC		
Overall Height	A	0.47	0.51	0.55	
Die Height	A2	0.33	0.35	0.37	
Bump Height	A1	0.14	0.16	0.18	
Overall Width	D	NOTE 4			
Overall Length	E	NOTE 4			
Ball Diameter	b	0.18	0.20	0.22	

**Notes:**

1. Orientation reference feature may vary, but must be located within the hatched area.
2. Package is saw singulated.
3. Dimensioning and tolerancing per ASME Y14.5M.  
 BSC: Basic Dimension. Theoretically exact value shown without tolerances.  
 REF: Reference Dimension, usually without tolerance, for information purposes only.
4. Package size varies with specific devices. Please see the specific Product Data Sheet.

---



---

## Footprint Outlines and Dimensions

---



---

### 4-Lead Chip Scale Package (CS) - [CSP]

**Note:** For the most current package drawings, please see the Microchip Packaging Specification located at <http://www.microchip.com/packaging>

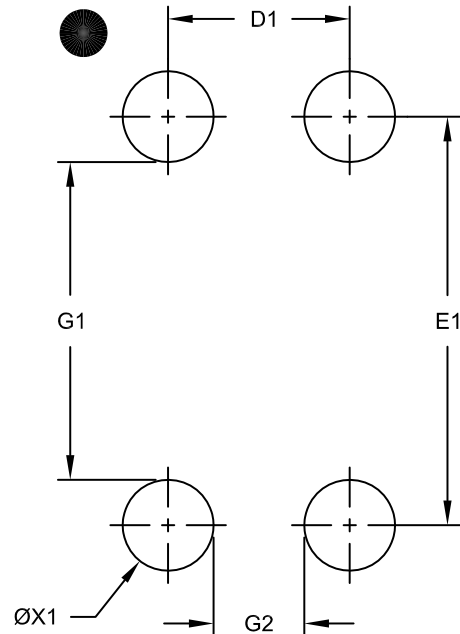

RECOMMENDED LAND PATTERN

		Units	MILLIMETERS		
		Dimension Limits	MIN	NOM	MAX
Number of Contacts	N		4		
Contact Pad Spacing	D1			0.40	
Contact Pad Spacing	E1			0.90	
Contact Pad Diameter (X4)	ØX1			0.20	
Distance Between Pads	G1			0.70	
Distance Between Pads	G2			0.20	

**Notes:**

1. Dimensioning and tolerancing per ASME Y14.5M

BSC: Basic Dimension. Theoretically exact value shown without tolerances.

Microchip Technology Drawing No. C04-8008A

**Package Outlines and Dimensions**

5-Lead Chip Scale Package (CS) - [CSP]

**Note:** For the most current package drawings, please see the Microchip Packaging Specification located at <http://www.microchip.com/packaging>

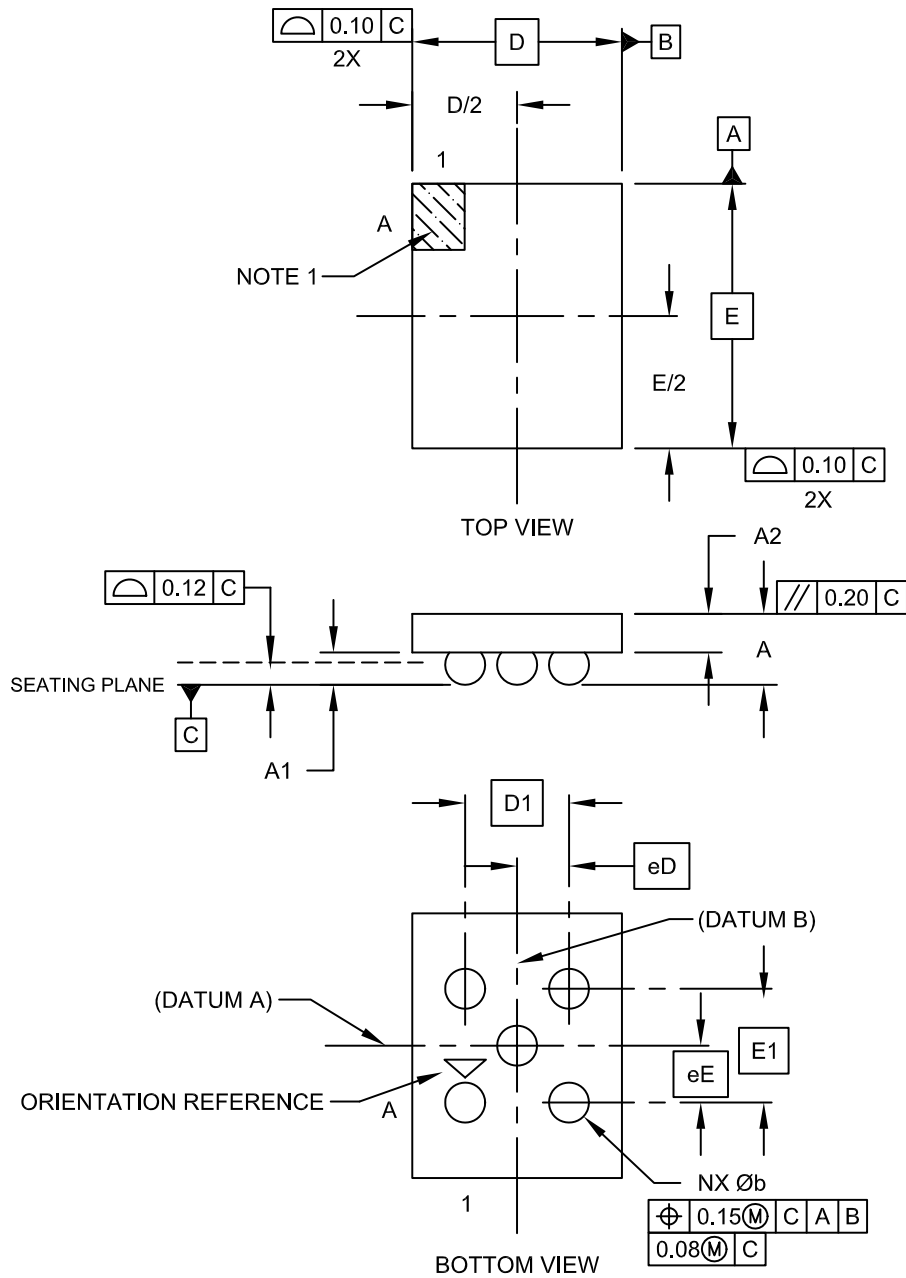

---



---

## Package Outlines and Dimensions

---



---

### 5-Lead Chip Scale Package (CS) - [CSP]

**Note:** For the most current package drawings, please see the Microchip Packaging Specification located at <http://www.microchip.com/packaging>

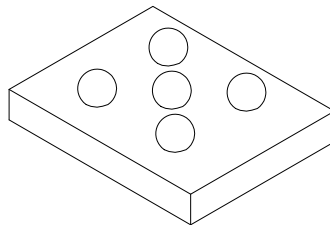

		Units	MILLIMETERS		
Dimension Limits			MIN	NOM	MAX
Number of Contacts	N			5	
Adjacent Column X-Pitch	E1		0.570 BSC		
Adjacent Row Y-Pitch	D1		0.520 BSC		
Adjacent Column X-Pitch	eE		0.285 BSC		
Adjacent Row Y-Pitch	eD		0.260 BSC		
Overall Height	A	0.47	0.51	0.55	
Die Height	A2	0.33	0.35	0.37	
Bump Height	A1	0.14	0.16	0.18	
Overall Length	E	NOTE 4			
Overall Width	D	NOTE 4			
Ball Diameter	b	0.18	0.20	0.22	

**Notes:**

1. Orientation reference feature may vary, but must be located within the hatched area.
2. Package is saw singulated.
3. Dimensioning and tolerancing per ASME Y14.5M.
  - BSC: Basic Dimension. Theoretically exact value shown without tolerances.
  - REF: Reference Dimension, usually without tolerance, for information purposes only.
4. Package size varies with specific devices. Please see the specific Product Data Sheet.

**Footprint Outlines and Dimensions**

**5-Lead Chip Scale Package (CS) - [CSP]**

**Note:** For the most current package drawings, please see the Microchip Packaging Specification located at <http://www.microchip.com/packaging>

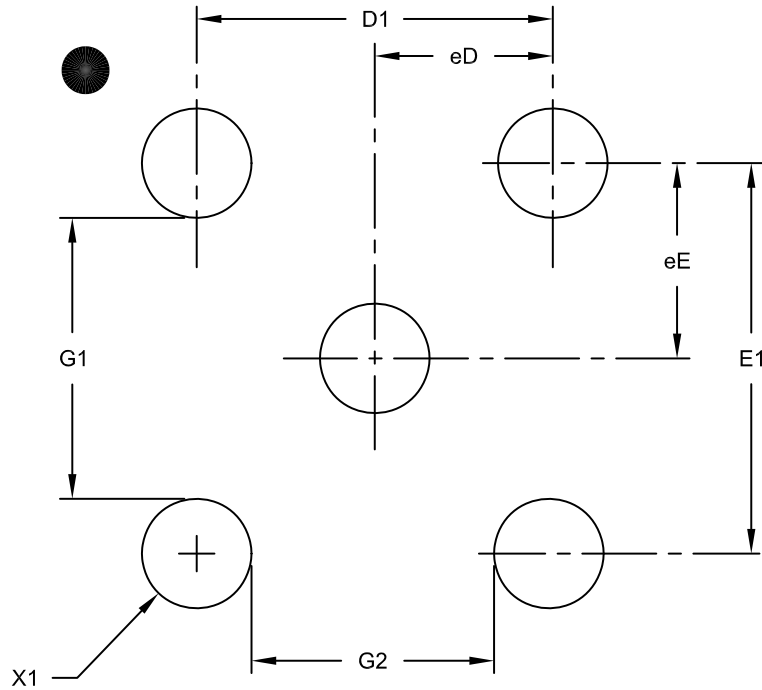

**RECOMMENDED LAND PATTERN**

Dimension Limits	Units	MILLIMETERS		
		MIN	NOM	MAX
Number of Contacts	N	5		
Contact Pitch Y	eE		0.285	
Contact Pitch X	eD		0.260	
Contact Pad Spacing	E1		0.570	
Contact Pad Spacing	D1		0.520	
Contact Pad Diameter (X5)	X1			0.20
Distance Between Pads	G1	0.41		
Distance Between Pads	G2	0.36		

Notes:

1. Dimensioning and tolerancing per ASME Y14.5M

BSC: Basic Dimension. Theoretically exact value shown without tolerances.

Microchip Technology Drawing No. C04-8004A



**Package Outlines and Dimensions**

**8-Ball Extremely Thin Fine Pitch Wafer Level Chip Scale Package (CS)**

**Note:** For the most current package drawings, please see the Microchip Packaging Specification located at <http://www.microchip.com/packaging>

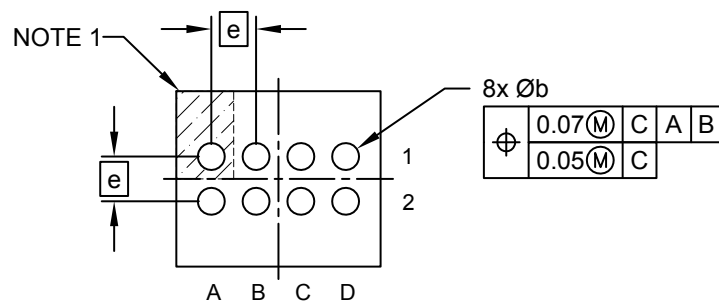
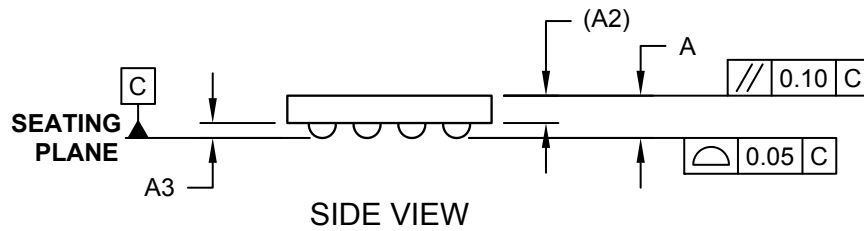
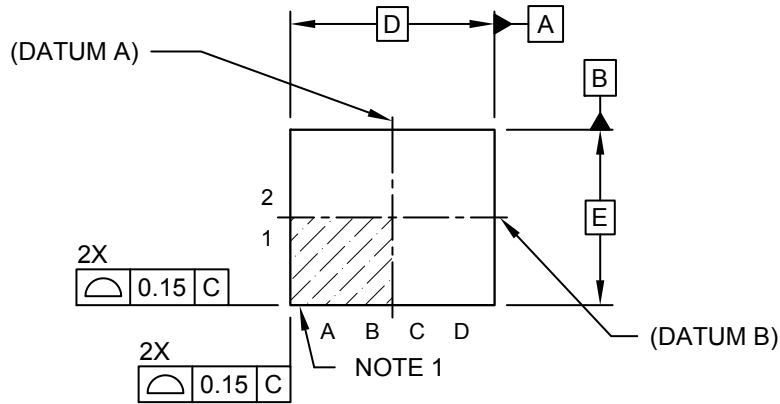

**Package Outlines and Dimensions**

**8-Ball Extremely Thin Fine Pitch Wafer Level Chip Scale Package (CS)**

**Note:** For the most current package drawings, please see the Microchip Packaging Specification located at <http://www.microchip.com/packaging>

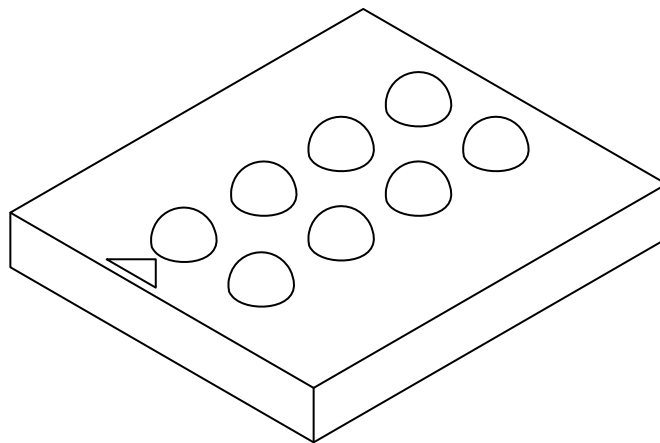

Units		MILLIMETERS		
Dimension Limits		MIN	NOM	MAX
Number of Balls	N	8		
Pitch	e	0.50 BSC		
Overall Height	A	0.442	0.472	0.512
Die Thickness	A2	0.30 REF		
Ball Height	A3	0.152	0.167	0.182
Overall Width	D	NOTE 4		
Overall Length	E	NOTE 4		
Ball Diameter	b	0.26	0.30	0.34

**Notes:**

1. Pin 1 visual index feature may vary, but must be located within the hatched area.
2. Package is saw singulated.
3. Dimensioning and tolerancing per ASME Y14.5M
  - BSC: Basic Dimension. Theoretically exact value shown without tolerances.
  - REF: Reference Dimension, usually without tolerance, for information purposes only.
4. Package size varies with specific devices. Please see the specific Product Data Sheet.

---



---

## Footprint Outlines and Dimensions

---



---

### 8-Ball Extremely Thin Fine Pitch Wafer Level Chip Scale Package (CS)

**Note:** For the most current package drawings, please see the Microchip Packaging Specification located at <http://www.microchip.com/packageing>

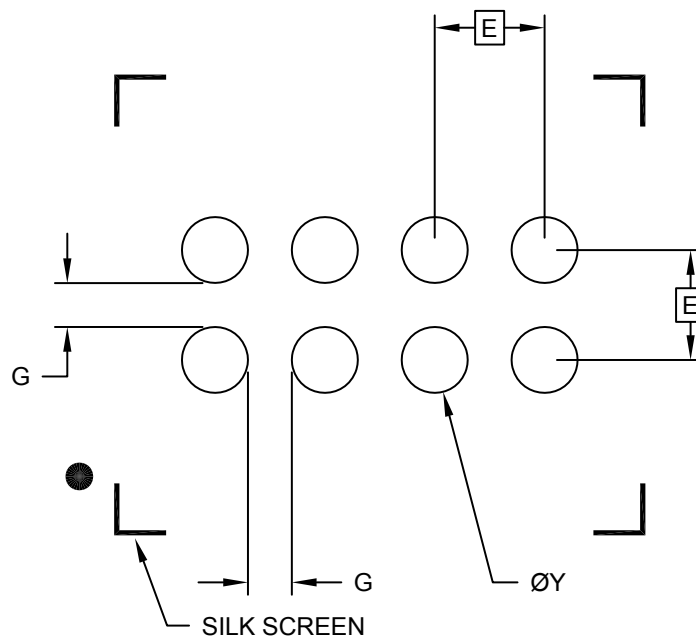

RECOMMENDED LAND PATTERN

	Units	MILLIMETERS		
		MIN	NOM	MAX
Dimension Limits				
Contact Pitch	E	0.50 BSC		
Contact Diameter	Y		0.30	
Distance Between Pads	G	0.20		

**Notes:**

1. Dimensioning and tolerancing per ASME Y14.5M

BSC: Basic Dimension. Theoretically exact value shown without tolerances.

Microchip Technology Drawing No. C04-8022-1A

## Package Outlines and Dimensions

### 9-Bump Wafer Level Chip Scale Package (CS) - [WLCSP or CSP]

**Note:** For the most current package drawings, please see the Microchip Packaging Specification located at <http://www.microchip.com/packaging>

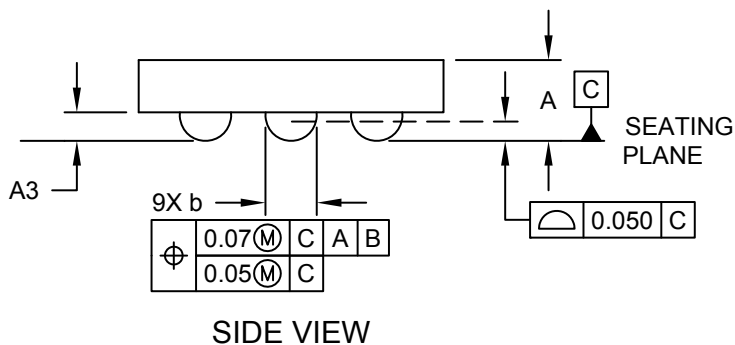
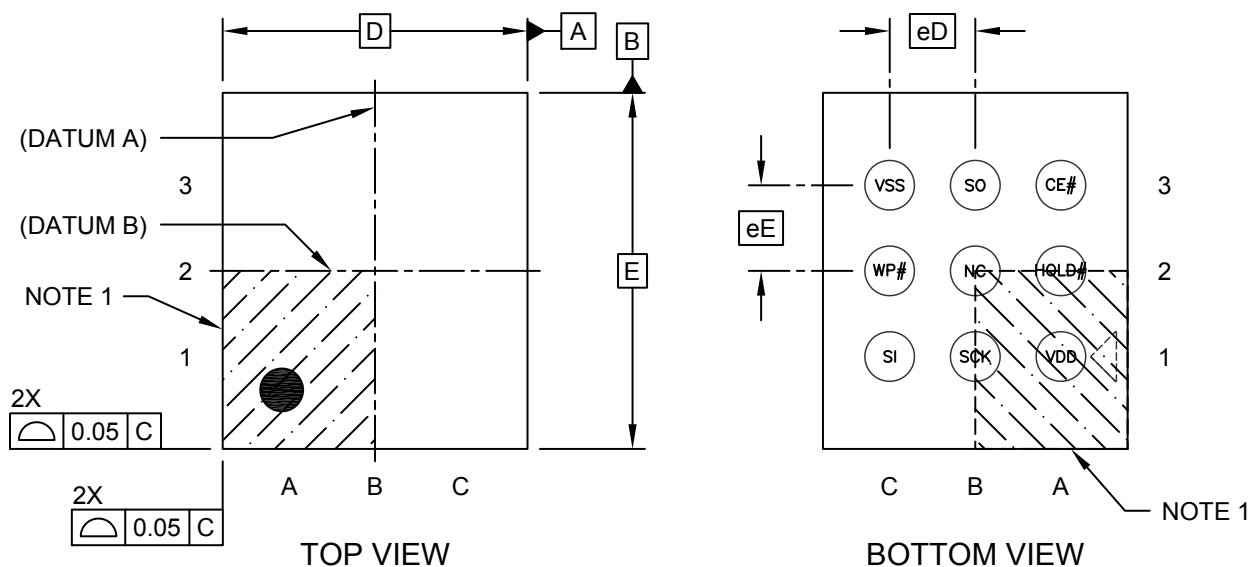

---



---

## Package Outlines and Dimensions

---



---

### 9-Bump Wafer Level Chip Scale Package (CS) - [WLCSP or CSP]

**Note:** For the most current package drawings, please see the Microchip Packaging Specification located at <http://www.microchip.com/packaging>

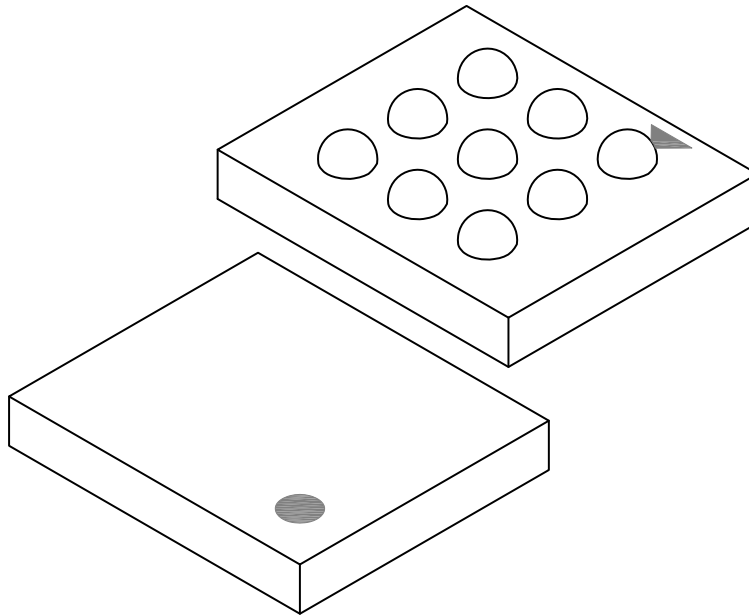

		Units	MILLIMETERS		
Dimension Limits			MIN	NOM	MAX
Bump Pitch	eD		0.50 BSC		
Bump Pitch	eE		0.50 BSC		
Length	D		NOTE 5		
Width	E		NOTE 5		
Overall Height	A		0.432	0.472	0.512
Bump Height	A3		0.152	0.167	0.182
Bump Diameter	b		0.260	0.300	0.340

**Notes:**

1. Topside A1 indicator is an engraved figure.
2. Under-fill is recommended for best solder joint reliability.
3. Solder diameter at interface to package body is 300 $\mu$ m (nominal).
4. Dimensioning and tolerancing per ASME Y14.5M
  - BSC: Basic Dimension. Theoretically exact value shown without tolerances.
  - REF: Reference Dimension, usually without tolerance, for information purposes only.
5. Package size varies with specific devices. Please contact your local Microchip representative for specific details.

**Footprint Outlines and Dimensions**

**9-Bump Wafer Level Chip Scale Package (CS) - [WLCSP or CSP]**

**Note:** For the most current package drawings, please see the Microchip Packaging Specification located at <http://www.microchip.com/packaging>

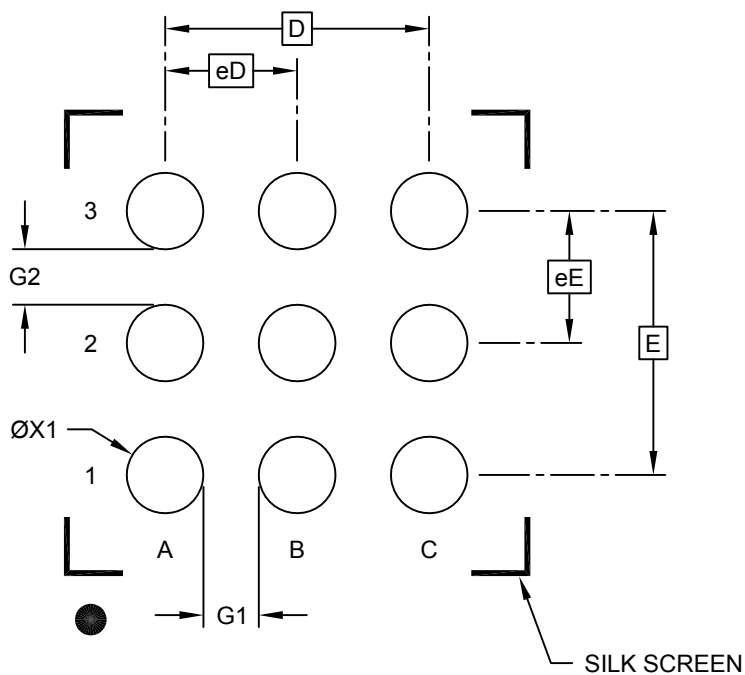

**RECOMMENDED LAND PATTERN**

Dimension Limits	Units	MILLIMETERS		
		MIN	NOM	MAX
Contact Pitch	eD		0.50 BSC	
Contact Pitch	eE		0.50 BSC	
Overall Pitch	D		1.00 BSC	
Overall Pitch	E		1.00 BSC	
Space Between Contacts	G1		0.20	
Space Between Contacts	G2		0.20	
Contact Diameter	ØX1		0.30	

**Notes:**

1. Dimensioning and tolerancing per ASME Y14.5M

BSC: Basic Dimension. Theoretically exact value shown without tolerances.

**Package Outlines and Dimensions**

**32-Lead Chip Scale Package (CS) - [CSP]**

**Note:** For the most current package drawings, please see the Microchip Packaging Specification located at <http://www.microchip.com/packaging>

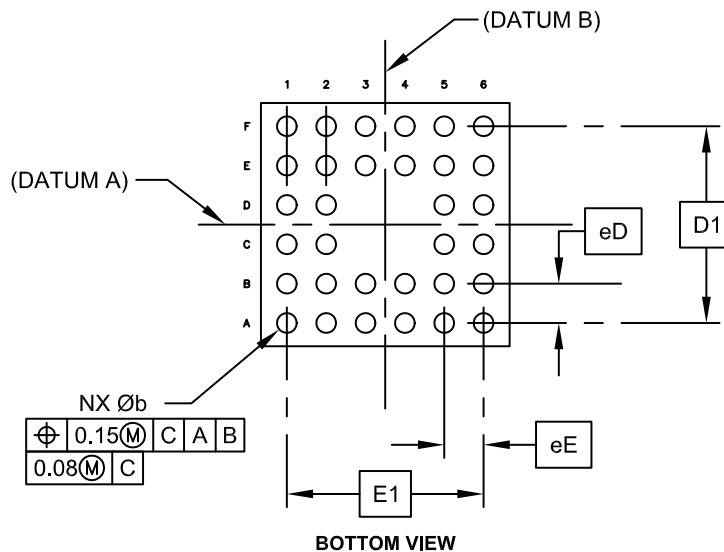
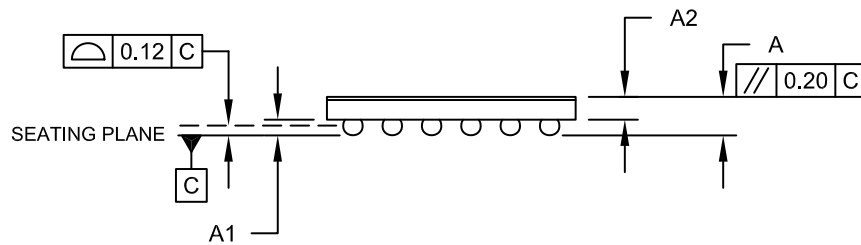
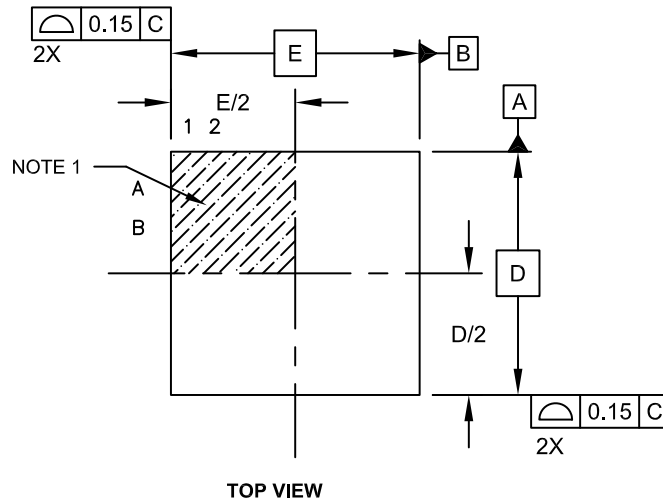

---



---

**Package Outlines and Dimensions**

---



---

**32-Lead Chip Scale Package (CS) - [CSP]**

**Note:** For the most current package drawings, please see the Microchip Packaging Specification located at <http://www.microchip.com/packaging>

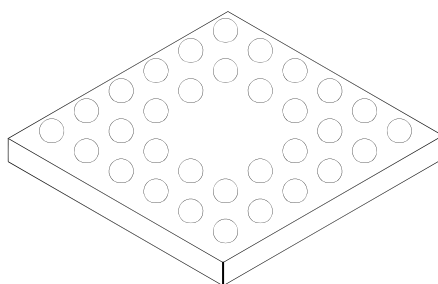

Dimension Limits	Units	MILLIMETERS		
		MIN	NOM	MAX
Number of Balls	N		32	
Overall Grid X-Pitch	E1	2.50 BSC		
Overall Grid Y-Pitch	D1	2.50 BSC		
Adjacent Column X-Pitch	eE	0.50 BSC		
Adjacent Row Y-Pitch	eD	0.50 BSC		
Overall Height	A	0.45	0.49	0.53
Bump Height	A1	0.18	0.20	0.22
Die Height	A2	0.27	0.29	0.31
Overall Width	E	NOTE 4		
Overall Length	D	NOTE 4		
Contact Diameter	b	0.23	0.25	0.27

**Notes:**

1. Orientation reference feature may vary, but must be located within the hatched area.
2. Package is saw singulated.
3. Dimensioning and tolerancing per ASME Y14.5M.
  - BSC: Basic Dimension. Theoretically exact value shown without tolerances.
  - REF: Reference Dimension, usually without tolerance, for information purposes only.
4. Package size varies with specific devices. Please see the specific Product Data Sheet.



---



---

## Footprint Outlines and Dimensions

---



---

### 32-Ball Wafer Level Chip Scale Package (CS) - [CSP]

**Note:** For the most current package drawings, please see the Microchip Packaging Specification located at <http://www.microchip.com/packaging>

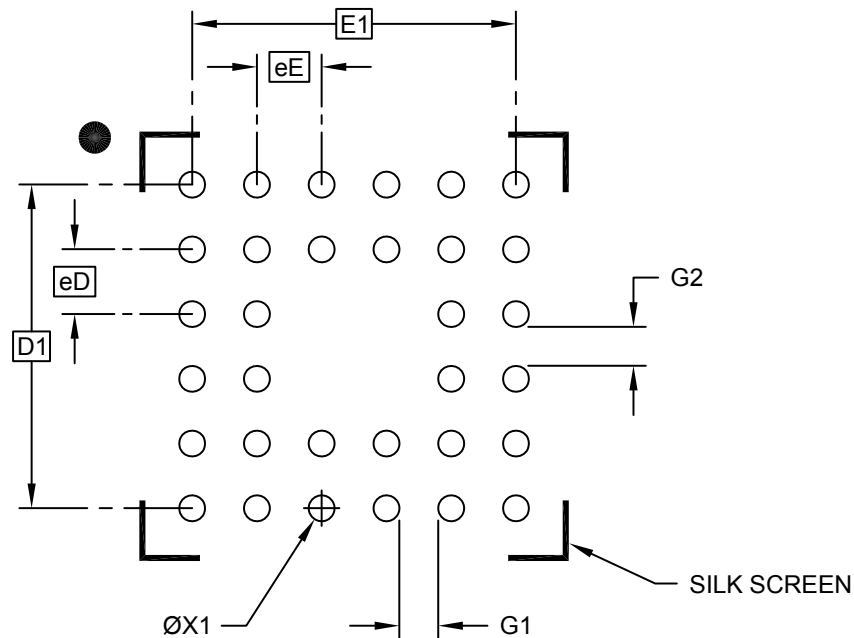

RECOMMENDED LAND PATTERN

Dimension Limits	Units	MILLIMETERS		
		MIN	NOM	MAX
Contact Pitch	eD		0.50 BSC	
Contact Pitch	eE		0.50 BSC	
Overall Pitch	D1		2.50 BSC	
Overall Pitch	E1		2.50 BSC	
Space Between Contacts	G1		0.30	
Space Between Contacts	G2		0.30	
Contact Diameter	ØX1		0.20	

**Notes:**

1. Dimensioning and tolerancing per ASME Y14.5M

BSC: Basic Dimension. Theoretically exact value shown without tolerances.

Microchip Technology Drawing C04-8014A



**MICROCHIP**

---

---

**Package Outlines and Dimensions**

---

---

NOTES:

---

---

**Package Outlines and Dimensions**

---

---

**WLCSP**

**Package Outlines and Dimensions**

**8-Bump Extremely Thin Fine Pitch Wafer Level Chip Scale Package (CS)**

**Note:** For the most current package drawings, please see the Microchip Packaging Specification located at <http://www.microchip.com/packaging>

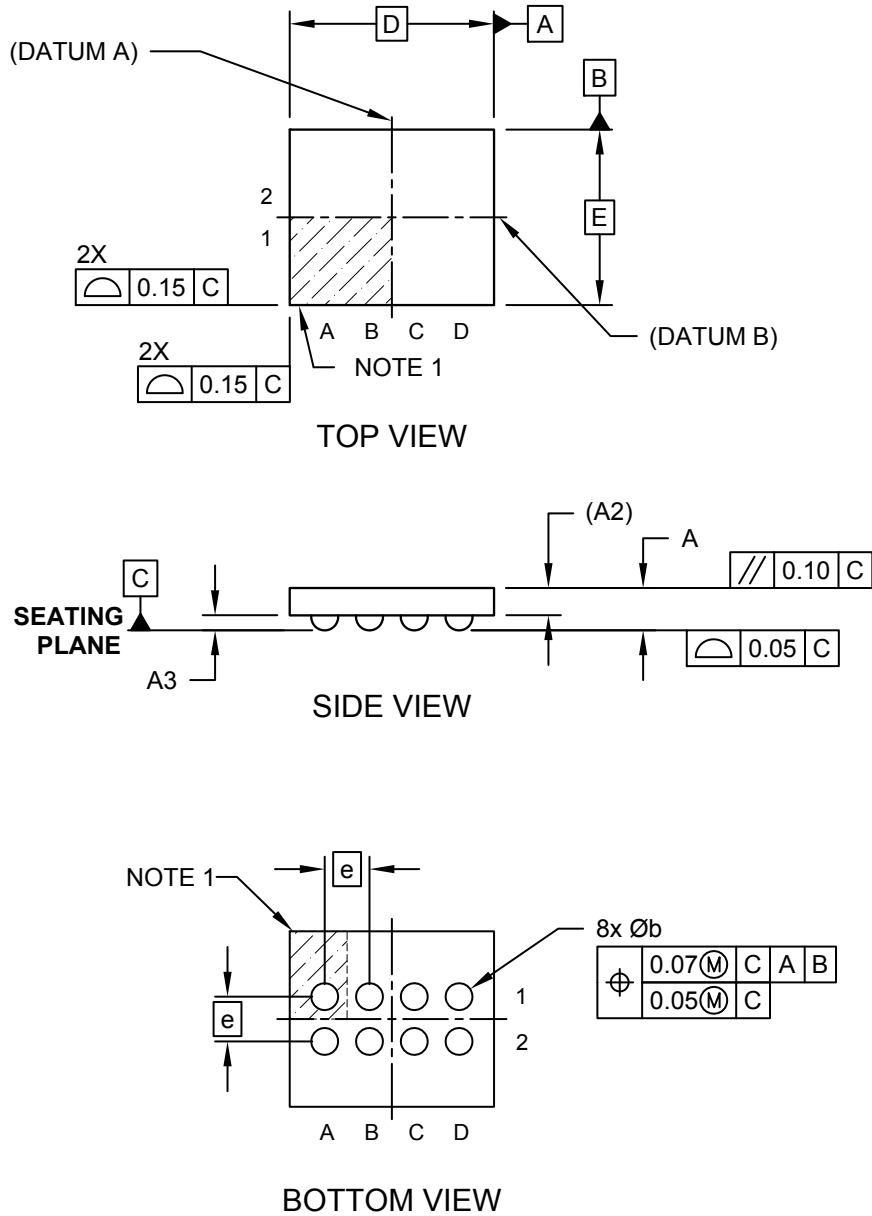

---



---

## Package Outlines and Dimensions

---



---

### 8-Bump Extremely Thin Fine Pitch Wafer Level Chip Scale Package (CS)

**Note:** For the most current package drawings, please see the Microchip Packaging Specification located at <http://www.microchip.com/packaging>

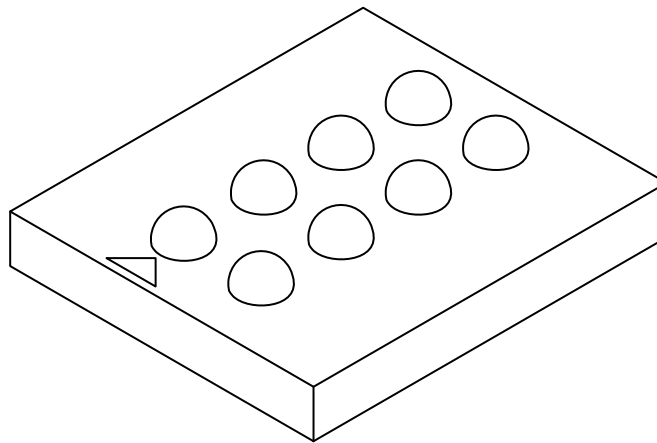

		Units	MILLIMETERS		
Dimension Limits			MIN	NOM	MAX
Number of Bumps	N		8		
Pitch	e		0.50 BSC		
Overall Height	A		0.442	0.472	0.512
Die Thickness	A2		0.30 REF		
Bump Height	A3		0.145	0.160	0.175
Overall Width	D		NOTE 4		
Overall Length	E		NOTE 4		
Bump Diameter	b		0.26	0.30	0.34

**Notes:**

1. Pin 1 visual index feature may vary, but must be located within the hatched area.
2. Package is saw singulated.
3. Dimensioning and tolerancing per ASME Y14.5M
  - BSC: Basic Dimension. Theoretically exact value shown without tolerances.
  - REF: Reference Dimension, usually without tolerance, for information purposes only.
4. Package size varies with specific devices. Please see the specific Product Data Sheet.

**Footprint Outlines and Dimensions**

**8-Bump Extremely Thin Fine Pitch Wafer Level Chip Scale Package (CS)**

**Note:** For the most current package drawings, please see the Microchip Packaging Specification located at <http://www.microchip.com/packaging>

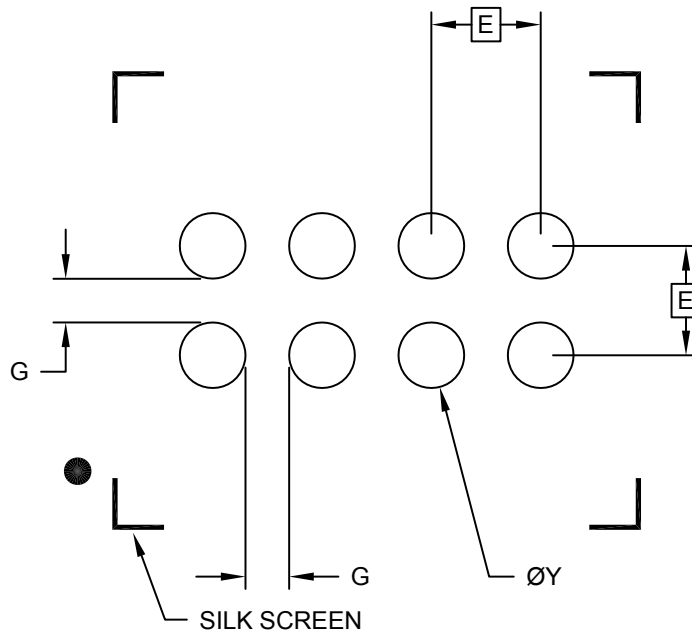

**RECOMMENDED LAND PATTERN**

Dimension Limits	Units	MILLIMETERS		
		MIN	NOM	MAX
Contact Pitch	E	0.50 BSC		
Contact Diameter	Y		0.30	
Distance Between Pads	G	0.20		

**Notes:**

1. Dimensioning and tolerancing per ASME Y14.5M

BSC: Basic Dimension. Theoretically exact value shown without tolerances.

Microchip Technology Drawing No. C04-8022-1A

## Package Outlines and Dimensions

### 9-Bump Wafer Level Chip Scale Package (CS) - [WLCSP or CSP]

**Note:** For the most current package drawings, please see the Microchip Packaging Specification located at <http://www.microchip.com/packaging>

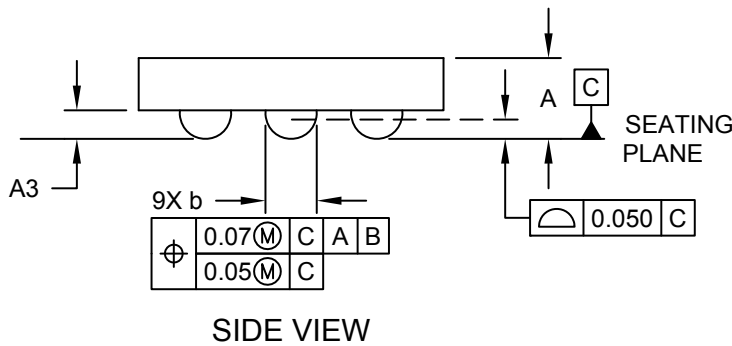
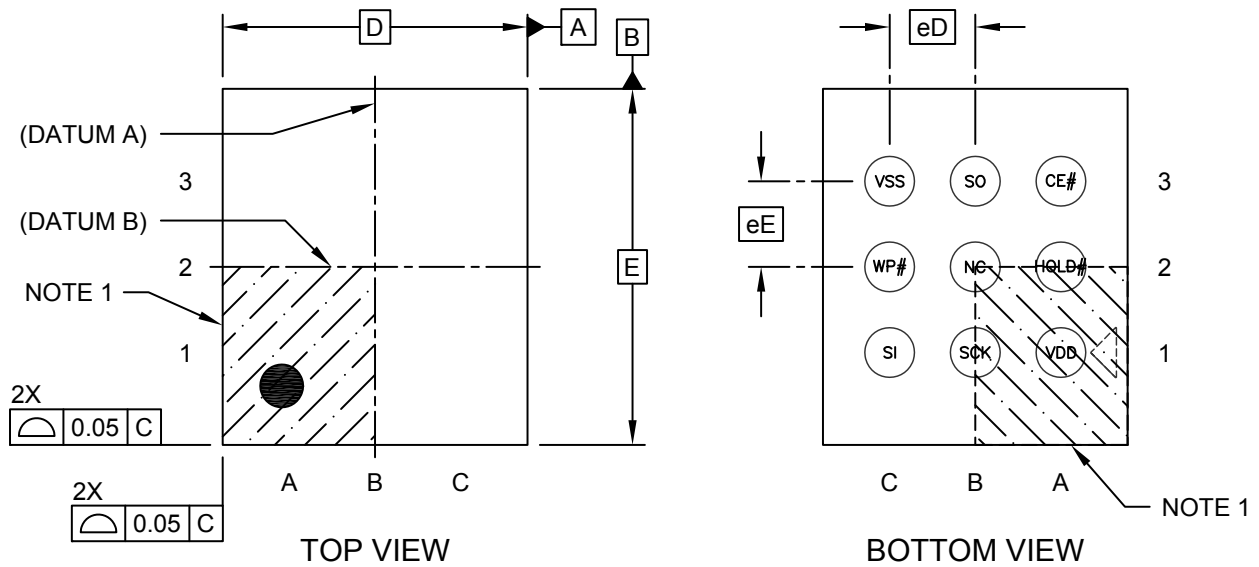

**Package Outlines and Dimensions**

**9-Bump Wafer Level Chip Scale Package (CS) - [WLCSP or CSP]**

**Note:** For the most current package drawings, please see the Microchip Packaging Specification located at <http://www.microchip.com/packaging>

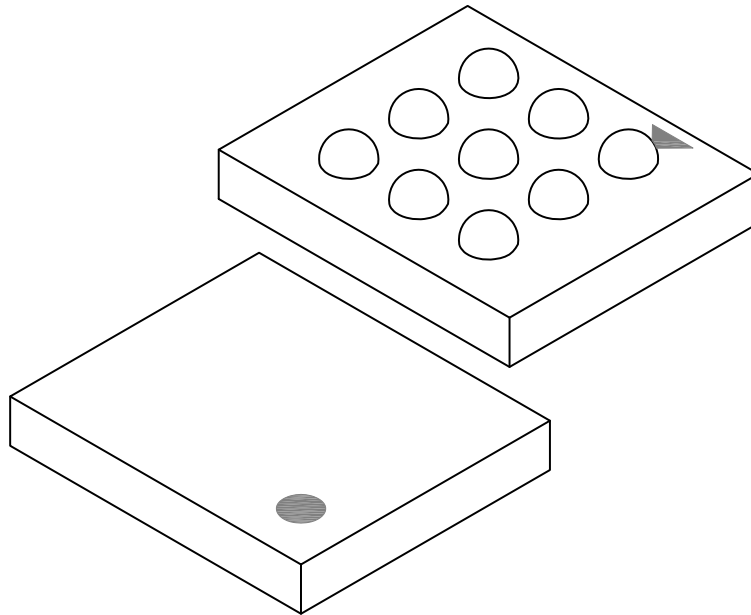

		Units	MILLIMETERS		
Dimension Limits			MIN	NOM	MAX
Bump Pitch	eD		0.50 BSC		
Bump Pitch	eE		0.50 BSC		
Length	D		NOTE 5		
Width	E		NOTE 5		
Overall Height	A		0.432	0.472	0.512
Bump Height	A3		0.152	0.167	0.182
Bump Diameter	b		0.260	0.300	0.340

Notes:

1. Topside A1 indicator is an engraved figure.
2. Under-fill is recommended for best solder joint reliability.
3. Solder diameter at interface to package body is 300µm (nominal).
4. Dimensioning and tolerancing per ASME Y14.5M
  - BSC: Basic Dimension. Theoretically exact value shown without tolerances.
  - REF: Reference Dimension, usually without tolerance, for information purposes only.
5. Package size varies with specific devices. Please contact your local Microchip representative for specific details.



---



---

## Footprint Outlines and Dimensions

---



---

### 9-Bump Wafer Level Chip Scale Package (CS) - [WLCSP or CSP]

**Note:** For the most current package drawings, please see the Microchip Packaging Specification located at <http://www.microchip.com/packaging>

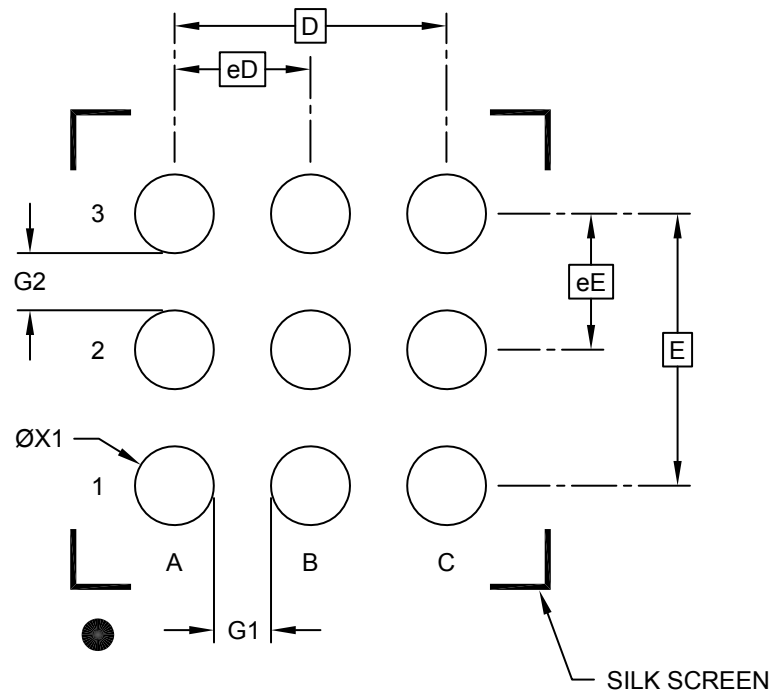

### RECOMMENDED LAND PATTERN

Dimension Limits	Units	MILLIMETERS		
		MIN	NOM	MAX
Contact Pitch	eD		0.50 BSC	
Contact Pitch	eE		0.50 BSC	
Overall Pitch	D		1.00 BSC	
Overall Pitch	E		1.00 BSC	
Space Between Contacts	G1		0.20	
Space Between Contacts	G2		0.20	
Contact Diameter	ØX1		0.30	

**Notes:**

1. Dimensioning and tolerancing per ASME Y14.5M

BSC: Basic Dimension. Theoretically exact value shown without tolerances.

**Package Outlines and Dimensions**

**14-Ball Wafer Level Chipscale Package (CS) - 1.57X2.36 Body [WLCSP] - PIC16LF1823**

**Note:** For the most current package drawings, please see the Microchip Packaging Specification located at <http://www.microchip.com/packaging>

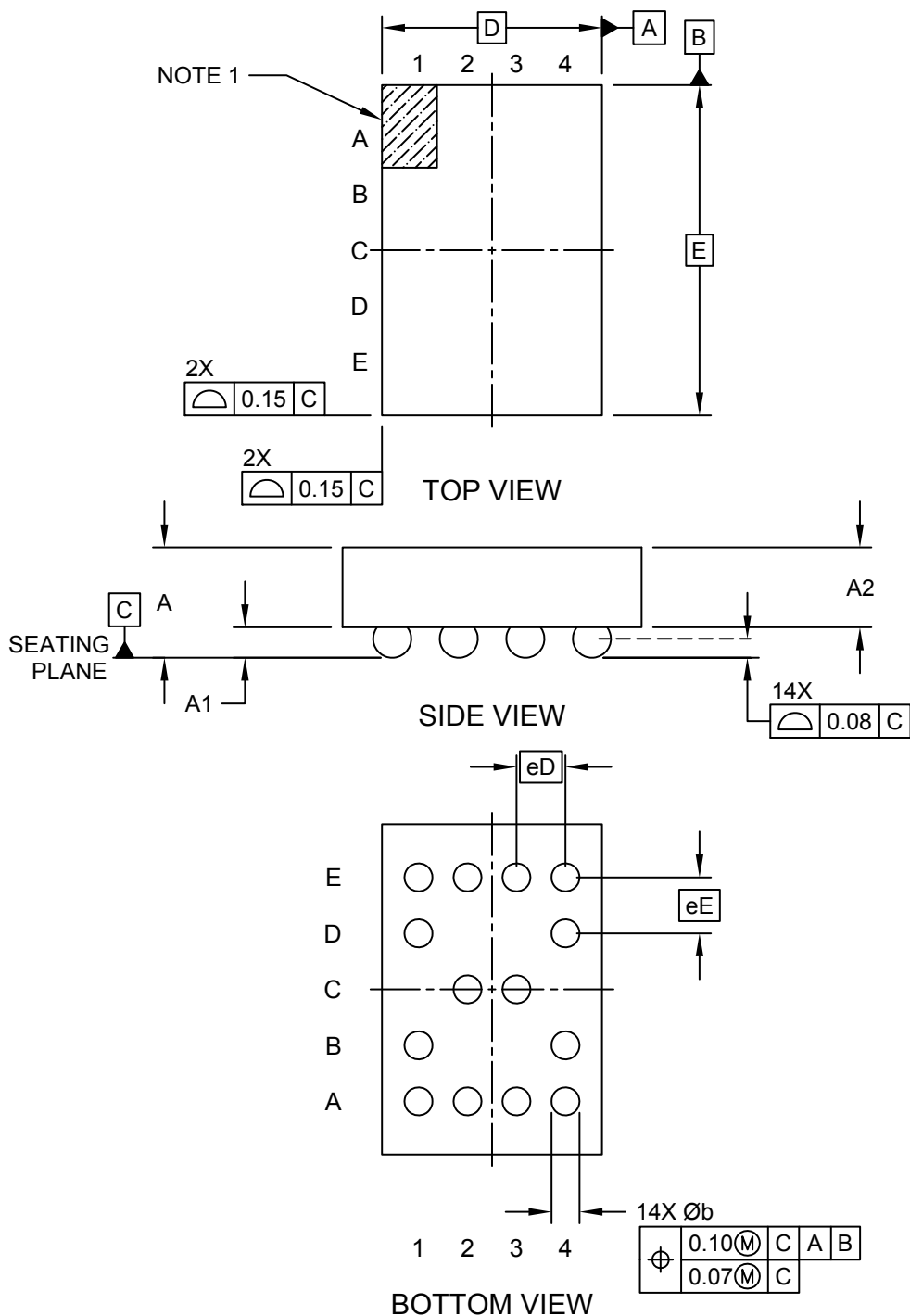

---



---

## Package Outlines and Dimensions

---



---

### 14-Ball Wafer Level Chipscale Package (CS) - 1.57X2.36 Body [WLCSP] - PIC16LF1823

**Note:** For the most current package drawings, please see the Microchip Packaging Specification located at <http://www.microchip.com/packaging>

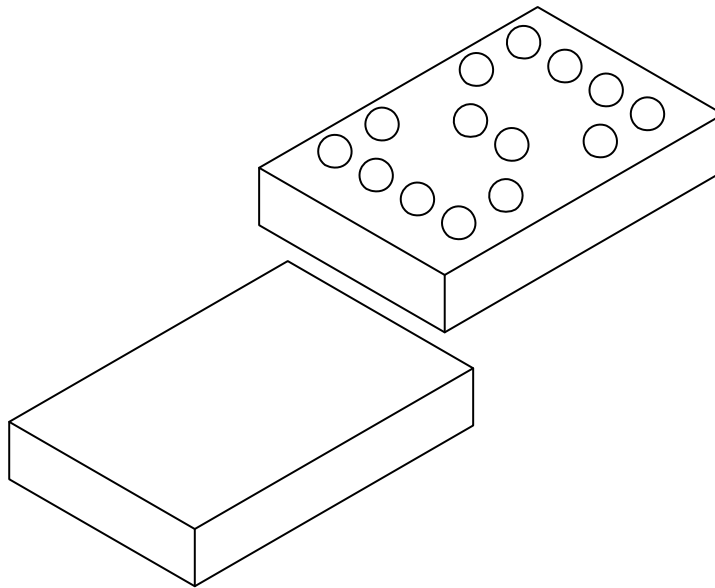

		MILLIMETERS		
Units				
Dimension Limits		MIN	NOM	MAX
Number of Terminals	N	14		
Pitch	eD	0.35 BSC		
Pitch	eE	0.40 BSC		
Overall Height	A	0.55	0.59	0.62
Bump Height	A1	0.14	0.16	0.18
Die Height	A2	0.41	0.43	0.44
Overall Width	D	1.57 BSC		
Overall Length	E	2.36 BSC		
Terminal Width	b	0.24	0.25	0.26
Terminal Length	L	0.30	0.40	0.50
Terminal-to-Exposed-Pad	K	0.20	-	-

**Notes:**

1. Terminal A1 visual index feature may vary, but must be located within the hatched area.
2. Package is saw singulated
3. Dimensioning and tolerancing per ASME Y14.5M

BSC: Basic Dimension. Theoretically exact value shown without tolerances.

REF: Reference Dimension, usually without tolerance, for information purposes only.

**Footprint Outlines and Dimensions**

**14-Ball Wafer Lever Chipscale Package (CS) - 1.57X2.36 Body [WLCSP] - PIC16LF1823**

**Note:** For the most current package drawings, please see the Microchip Packaging Specification located at <http://www.microchip.com/packaging>

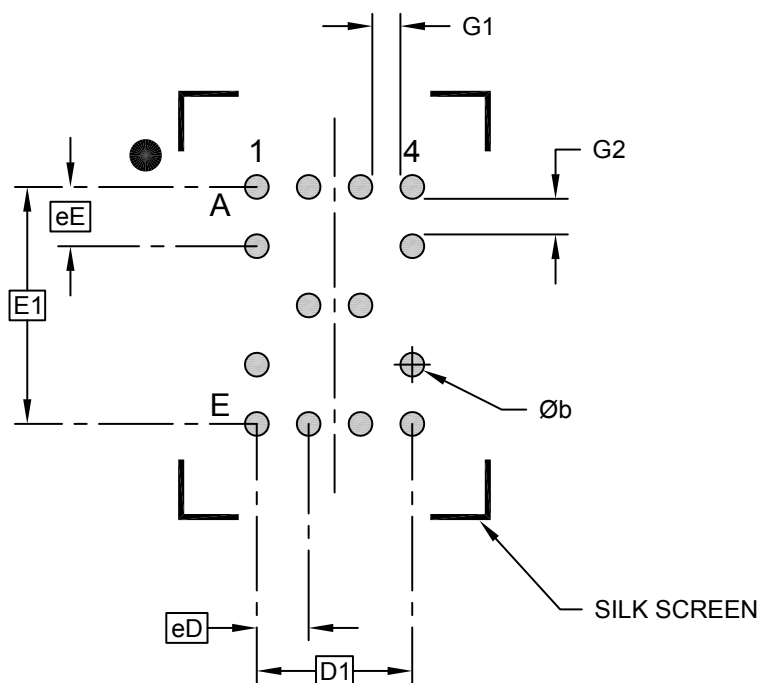

RECOMMENDED LAND PATTERN

Dimension Limits	Units	MILLIMETERS		
		MIN	NOM	MAX
Contact Pitch	eD	0.35 BSC		
Contact Pitch	eE	0.40 BSC		
Overall Pitch	D1	1.05 BSC		
Overall Pitch	E1	1.60 BSC		
Contact Pad Diameter	b	0.15	0.16	0.17
Contact Pad Spacing	G1	0.23		
Contact Pad Spacing	G2	0.18		

Notes:

1. Dimensioning and tolerancing per ASME Y14.5M

BSC: Basic Dimension. Theoretically exact value shown without tolerances.

Microchip Technology Drawing C04-8009B

**Package Outlines and Dimensions**

**16-Ball Wafer Level Chip Scale Package (CS) - 2.215x2.16x0.7 mm Body [WLCSP]**

**Note:** For the most current package drawings, please see the Microchip Packaging Specification located at <http://www.microchip.com/packaging>

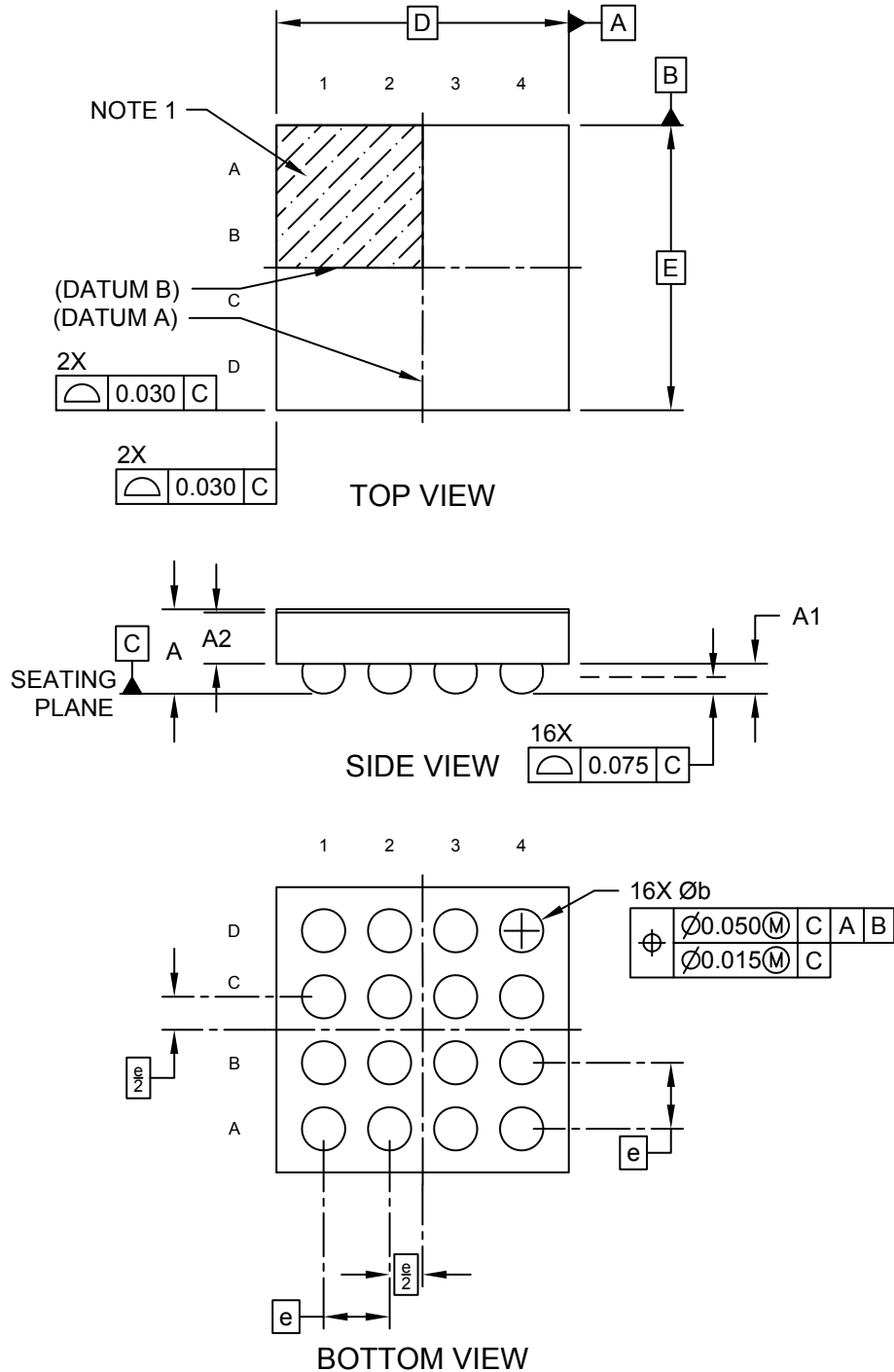

---



---

**Package Outlines and Dimensions**

---



---

**16-Ball Wafer Level Chip Scale Package (CS) - 2.215x2.16x0.7 mm Body [WLCSP]**

**Note:** For the most current package drawings, please see the Microchip Packaging Specification located at <http://www.microchip.com/packaging>

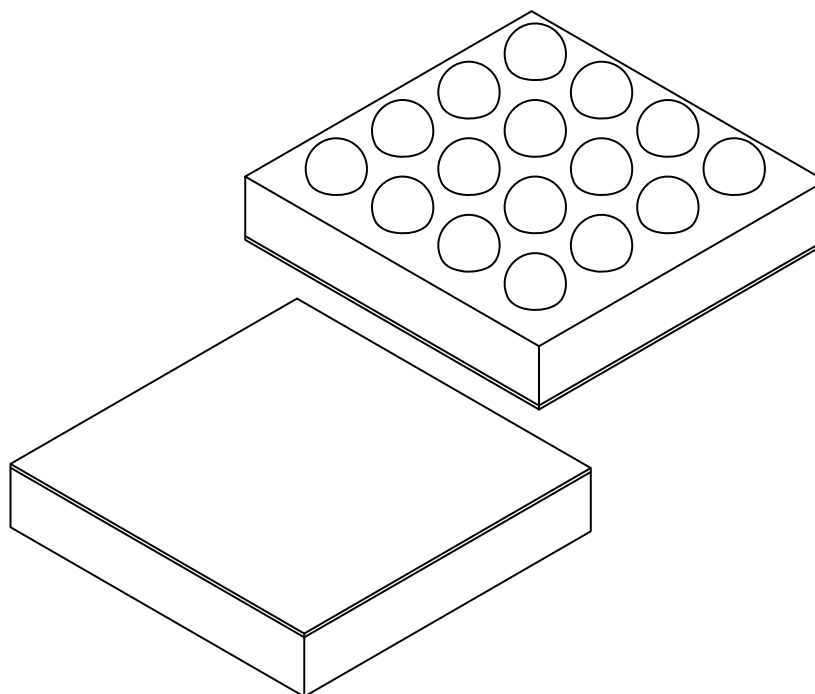

Units		MILLIMETERS		
		MIN	NOM	MAX
Dimension Limits				
Number of Terminals	N	16		
Pitch	e	0.50 BSC		
Overall Height	A	0.601	0.641	0.679
Standoff	A1	0.197	-	0.257
Die Thickness	A2	0.363	0.388	0.413
Overall Length	D	2.215 BSC		
Overall Width	E	2.160 BSC		
Terminal Diameter	b	0.297	0.327	0.357

**Notes:**

1. Pin 1 visual index feature may vary, but must be located within the hatched area.
2. Dimensioning and tolerancing per ASME Y14.5M
  - BSC: Basic Dimension. Theoretically exact value shown without tolerances.
  - REF: Reference Dimension, usually without tolerance, for information purposes only.

---

---

**Package Outlines and Dimensions**

---

---

**LLGA**

**Package Outlines and Dimensions**

**6-Lead Low Profile Land Grid Array (ANA) - 5.0x3.2 mm Body [LLGA]**

**Note:** For the most current package drawings, please see the Microchip Packaging Specification located at <http://www.microchip.com/packaging>

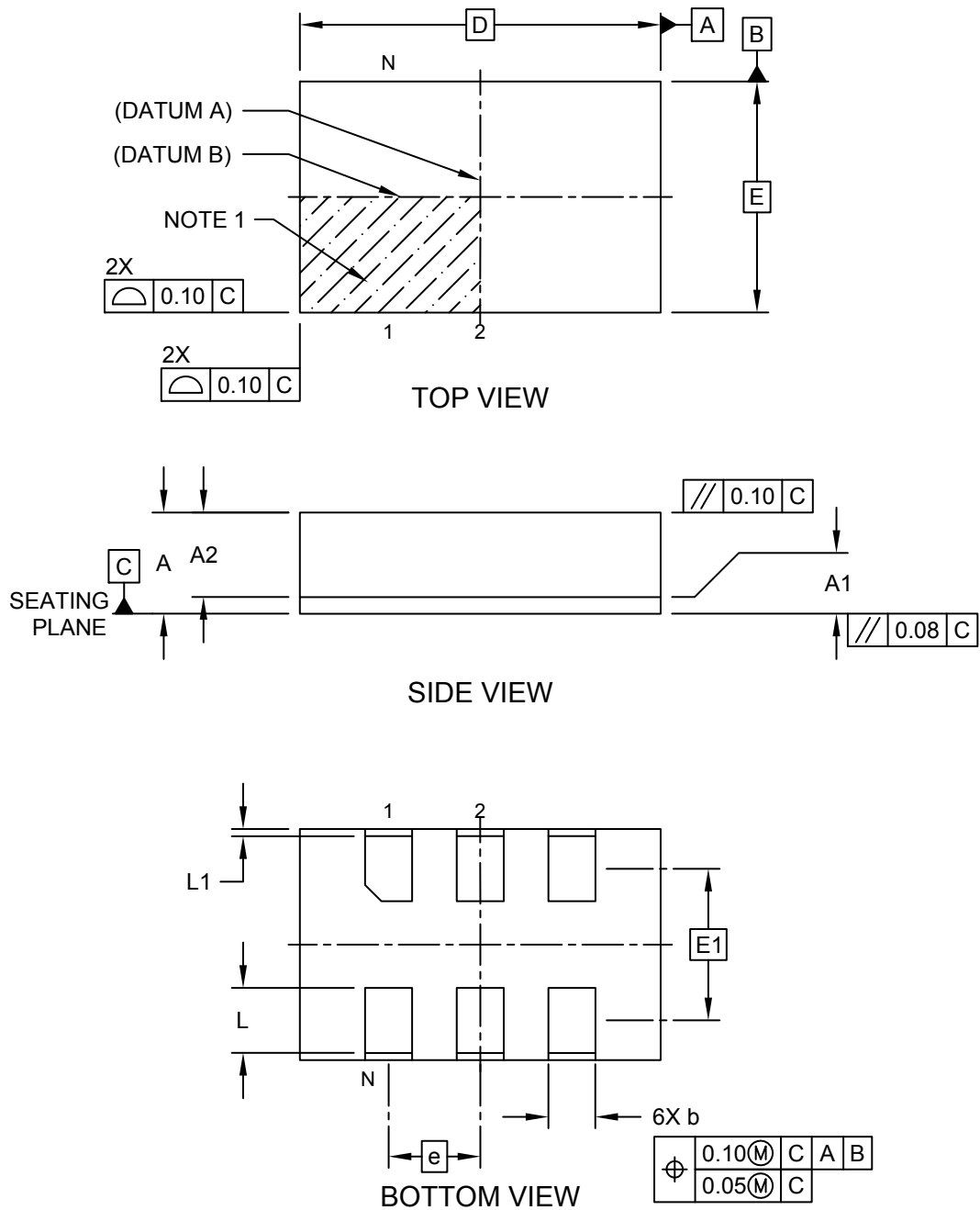



---



---

## Package Outlines and Dimensions

---



---

### 6-Lead Low Profile Land Grid Array (ANA) - 5.0x3.2 mm Body [LLGA]

**Note:** For the most current package drawings, please see the Microchip Packaging Specification located at <http://www.microchip.com/packaging>

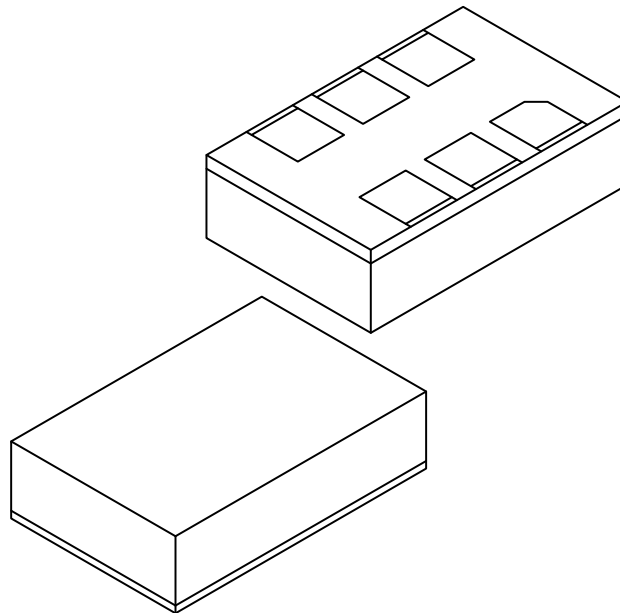

		Units	MILLIMETERS		
Dimension Limits			MIN	NOM	MAX
Number of Terminals	N		6		
Pitch	e		1.27 BSC		
Overall Height	A	1.26	1.33	1.40	
Substrate Thickness	A1	0.19	0.23	0.27	
Mold Cap Height	A2	1.07	1.10	1.13	
Overall Length	D	5.00 BSC			
Overall Width	E	3.20 BSC			
Terminal Pitch	E1	2.10 BSC			
Terminal Width	b	0.85	0.90	0.95	
Terminal Length	L	0.85	0.90	0.95	
Terminal Pullback	L1	0.05	0.10	0.15	

**Notes:**

1. Pin 1 visual index feature may vary, but must be located within the hatched area.
2. Dimensioning and tolerancing per ASME Y14.5M
  - BSC: Basic Dimension. Theoretically exact value shown without tolerances.
  - REF: Reference Dimension, usually without tolerance, for information purposes only.

**Footprint Outlines and Dimensions**

**6-Lead Low Profile Land Grid Array (ANA) - 5.0x3.2 mm Body [LLGA]**

**Note:** For the most current package drawings, please see the Microchip Packaging Specification located at <http://www.microchip.com/packaging>

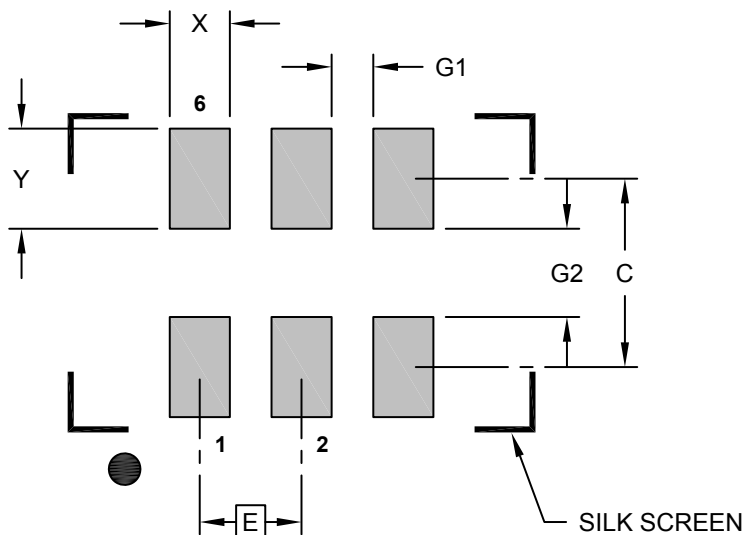

**RECOMMENDED LAND PATTERN**

Dimension Limits	Units	MILLIMETERS		
		MIN	NOM	MAX
Contact Pitch	E	1.27 BSC		
Contact Pad Spacing	C		2.35	
Contact Pad Width (X6)	X			0.75
Contact Pad Length (X6)	Y			1.25
Spacing Between Pads (X4)	G1	0.52		
Spacing Between Pads (X3)	G2	1.10		

**Notes:**

- Dimensioning and tolerancing per ASME Y14.5M  
BSC: Basic Dimension. Theoretically exact value shown without tolerances.
- For best soldering results, thermal vias, if used, should be filled or tented to avoid solder loss during reflow process

**Package Outlines and Dimensions**

**6-Lead Low Profile Land Grid Array [APA] - 7x5 mm Body (LLGA)**

**Note:** For the most current package drawings, please see the Microchip Packaging Specification located at <http://www.microchip.com/packaging>

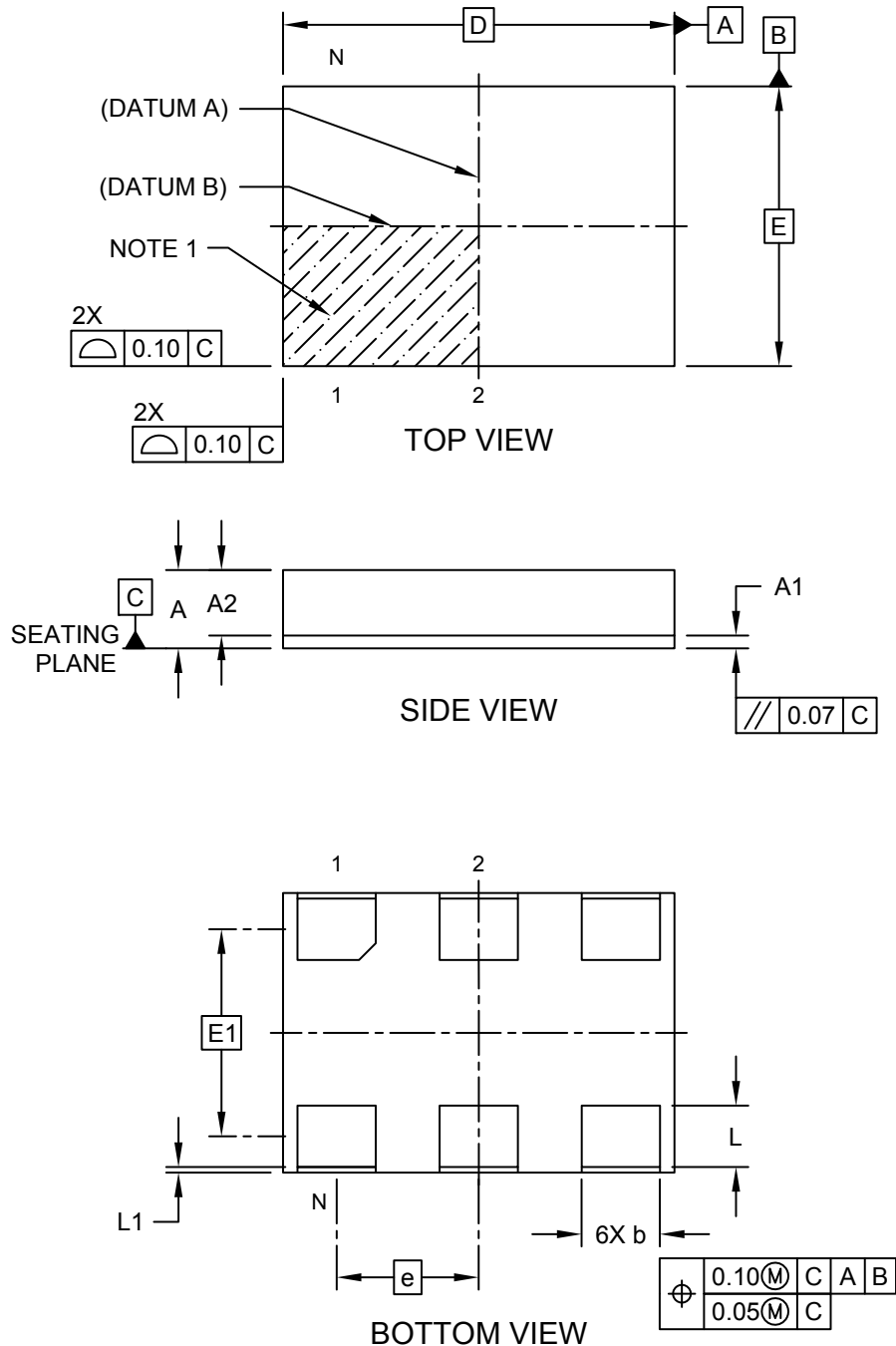

---



---

**Package Outlines and Dimensions**

---



---

**6-Lead Low Profile Land Grid Array (ANA) - 5.0x3.2 mm Body [LLGA]**

**Note:** For the most current package drawings, please see the Microchip Packaging Specification located at <http://www.microchip.com/packaging>

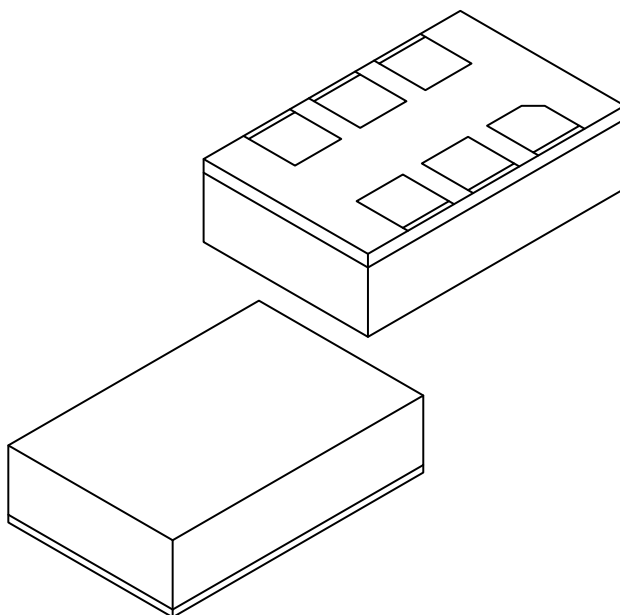

		Units	MILLIMETERS		
Dimension Limits			MIN	NOM	MAX
Number of Terminals	N		6		
Pitch	e		1.27 BSC		
Overall Height	A	1.26	1.33	1.40	
Substrate Thickness	A1	0.19	0.23	0.27	
Mold Cap Height	A2	1.07	1.10	1.13	
Overall Length	D	5.00 BSC			
Overall Width	E	3.20 BSC			
Terminal Pitch	E1	2.10 BSC			
Terminal Width	b	0.85	0.90	0.95	
Terminal Length	L	0.85	0.90	0.95	
Terminal Pullback	L1	0.05	0.10	0.15	

**Notes:**

1. Pin 1 visual index feature may vary, but must be located within the hatched area.
2. Dimensioning and tolerancing per ASME Y14.5M

BSC: Basic Dimension. Theoretically exact value shown without tolerances.

REF: Reference Dimension, usually without tolerance, for information purposes only.

---



---

## Footprint Outlines and Dimensions

---



---

### 6-Lead Low Profile Land Grid Array [APA] - 7x5 mm Body (LLGA)

**Note:** For the most current package drawings, please see the Microchip Packaging Specification located at <http://www.microchip.com/packaging>

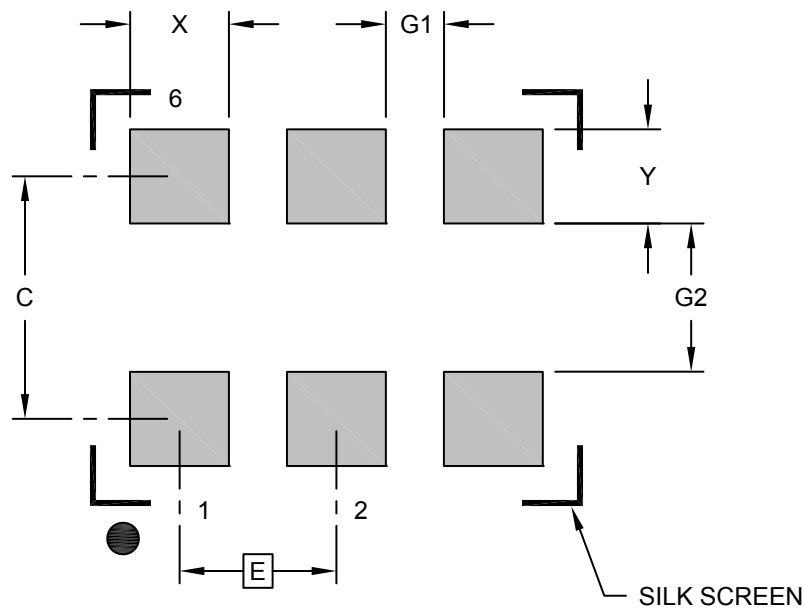

RECOMMENDED LAND PATTERN

Dimension Limits	Units	MILLIMETERS		
		MIN	NOM	MAX
Contact Pitch	E	2.54 BSC		
Contact Pad Spacing	C		3.93	
Contact Pad Width (X6)	X			1.60
Contact Pad Length (X6)	Y			1.53
Contact to Contact (X4)	G1	0.94		
Contact to Contact (X3)	G2	2.40		

**Notes:**

1. Dimensioning and tolerancing per ASME Y14.5M  
 BSC: Basic Dimension. Theoretically exact value shown without tolerances.



**MICROCHIP**

---

---

**Package Outlines and Dimensions**

---

---

NOTES:

---

---

**Package Outlines and Dimensions**

---

---

**VLGA**

**Package Outlines and Dimensions**

**6-Lead Very Thin Land Grid Array (ALA) - 3.2x2.5 mm Body [VLGA]**

**Note:** For the most current package drawings, please see the Microchip Packaging Specification located at <http://www.microchip.com/packaging>

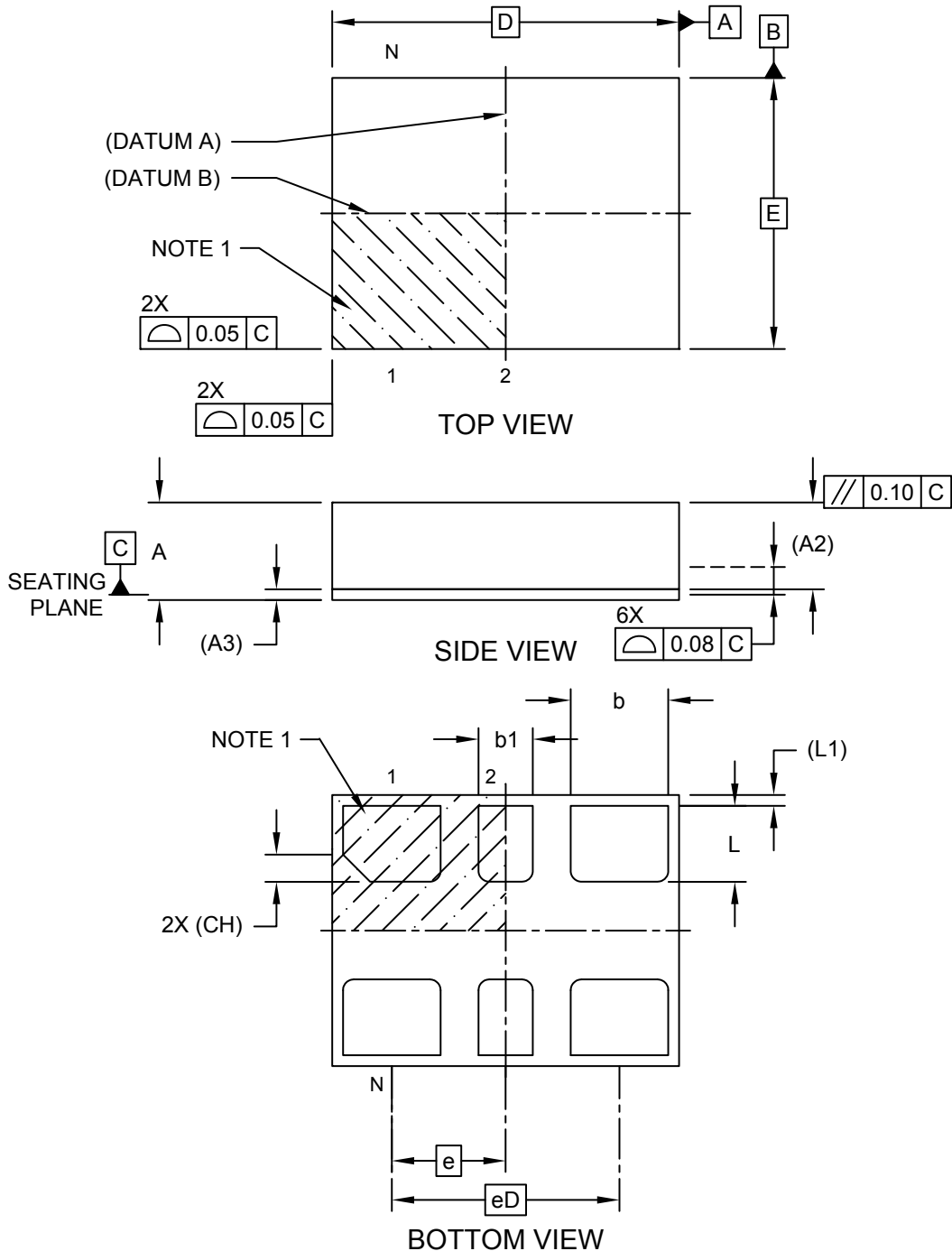



---



---

## Package Outlines and Dimensions

---



---

### 6-Lead Very Thin Land Grid Array (ALA) - 3.2x2.5 mm Body [VLGA]

**Note:** For the most current package drawings, please see the Microchip Packaging Specification located at <http://www.microchip.com/packaging>

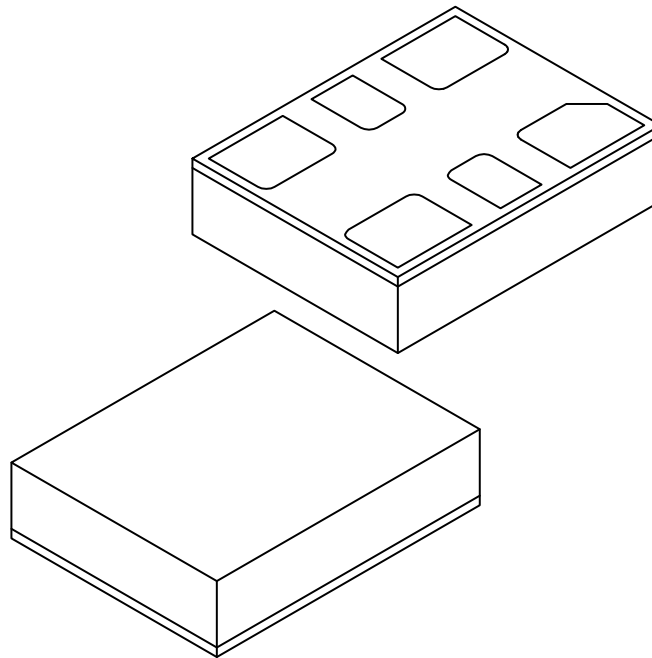

Dimension Limits	Units	MILLIMETERS		
		MIN	NOM	MAX
Number of Terminals	N	6		
Pitch	e	1.05 BSC		
Overall Pitch	eD	2.10 BSC		
Overall Height	A	0.70	0.80	0.90
Molded Cap Height	A2	0.70 REF		
Substrate Thickness	A3	0.10 REF		
Overall Length	D	3.20 BSC		
Overall Width	E	2.50 BSC		
Terminal Width	b	0.85	0.90	0.95
Terminal Width	b1	0.45	0.50	0.55
Terminal Length	L	0.65	0.70	0.75
Terminal Pullback	L1	0.10 REF		
Terminal 1 Corner Chamfer	CH	0.25 REF		

**Notes:**

1. Pin 1 visual index feature may vary, but must be located within the hatched area.
2. Package is saw singulated
3. Dimensioning and tolerancing per ASME Y14.5M

BSC: Basic Dimension. Theoretically exact value shown without tolerances.

REF: Reference Dimension, usually without tolerance, for information purposes only.

**Package Outlines and Dimensions**

**6-Lead Very Thin Land Grid Array (ALA) - 3.2x2.5 mm Body [VLGA]**

**Note:** For the most current package drawings, please see the Microchip Packaging Specification located at <http://www.microchip.com/packaging>

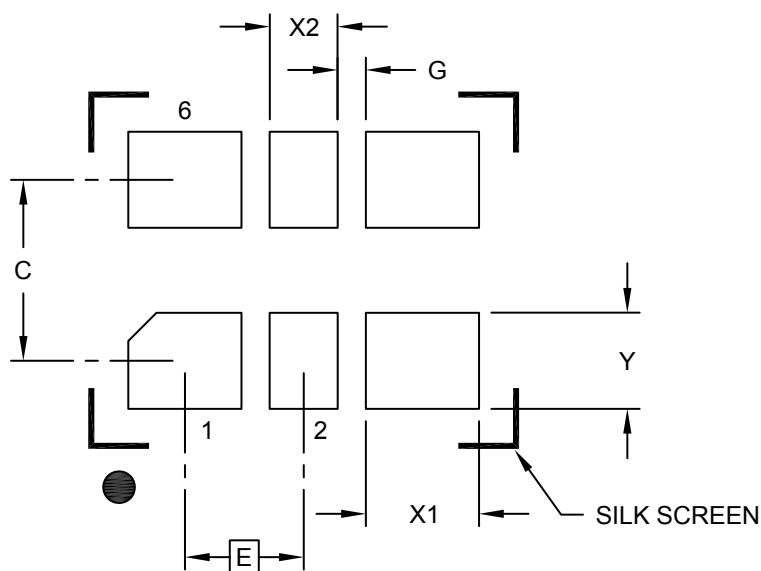

**RECOMMENDED LAND PATTERN**

Dimension Limits	Units	MILLIMETERS		
		MIN	NOM	MAX
Contact Pitch	E	1.05 BSC		
Contact Pad Spacing	C		1.60	
Contact Pad Width (X4)	X1			1.00
Contact Pad Width (X2)	X2			0.60
Contact Pad Length (X6)	Y			0.85
Space Between Contacts (X4)	G1	0.25		

**Notes:**

1. Dimensioning and tolerancing per ASME Y14.5M

BSC: Basic Dimension. Theoretically exact value shown without tolerances.

---

---

**Package Outlines and Dimensions**

---

---

**CABGA**

**Package Outlines and Dimensions**

**22-Ball Chip Array Ball Grid Array (JY) - 5x7 mm Body [CABGA]**

**Note:** For the most current package drawings, please see the Microchip Packaging Specification located at <http://www.microchip.com/packaging>

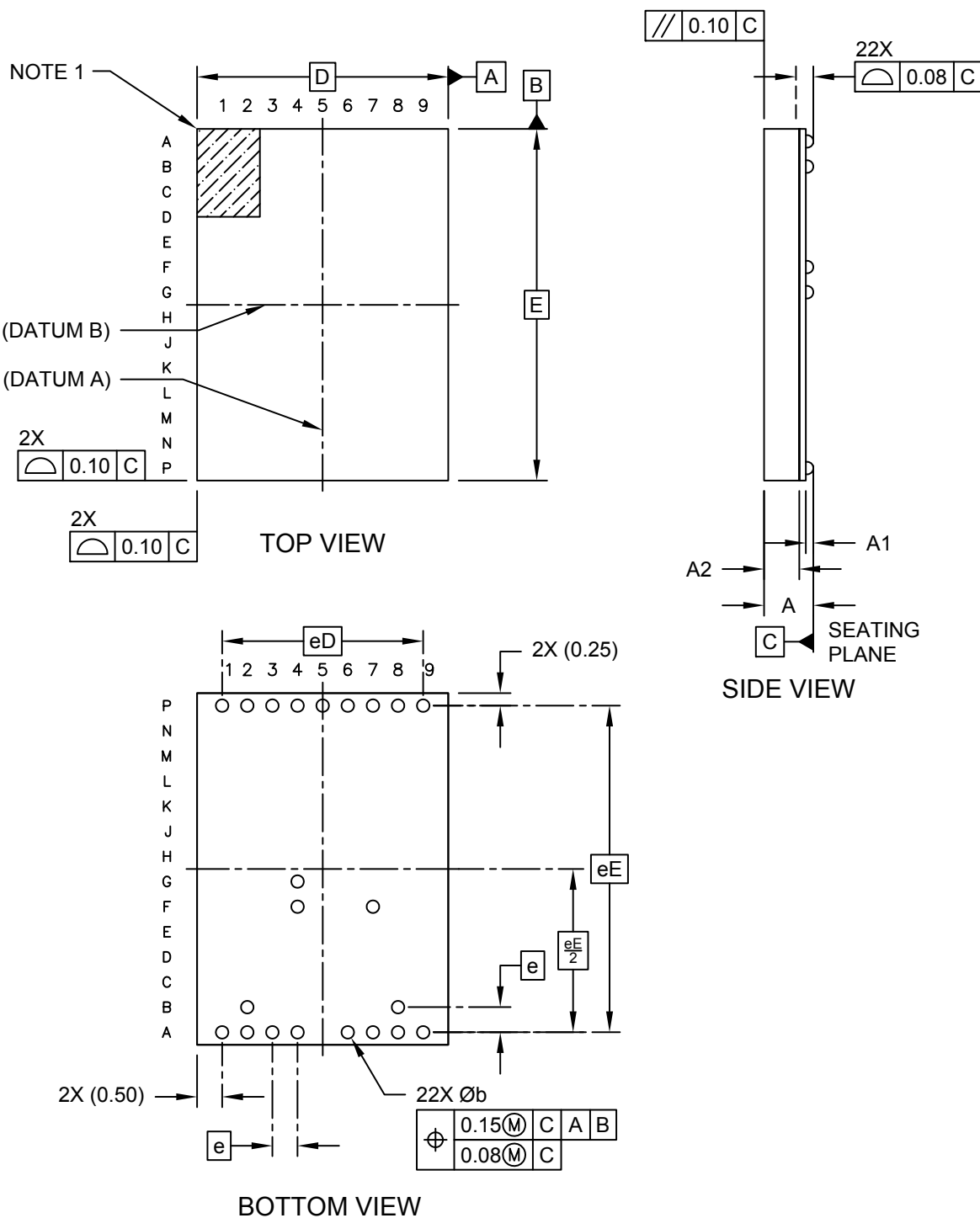

---



---

## Package Outlines and Dimensions

---



---

### 22-Ball Chip Array Ball Grid Array (JY) - 5x7 mm Body [CABGA]

**Note:** For the most current package drawings, please see the Microchip Packaging Specification located at <http://www.microchip.com/packaging>

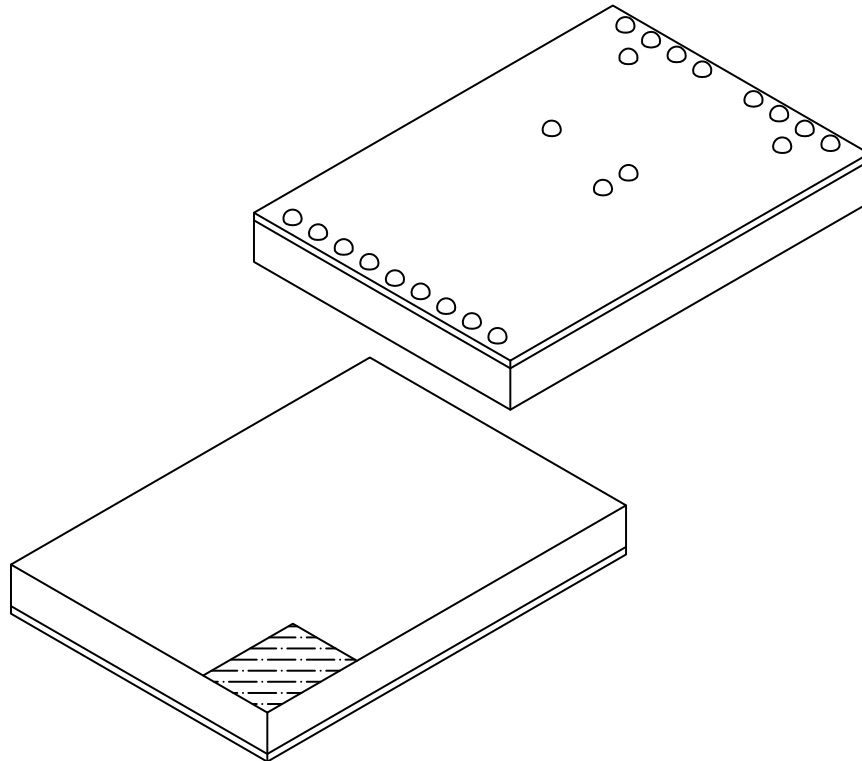

Dimension Limits	Units	MILLIMETERS		
		MIN	NOM	MAX
Number of Terminals	-	22		
Pitch	e	0.50 BSC		
Overall Height	A	0.91	0.98	1.05
Ball Height	A1	0.12	0.15	-
Package Thickness	A2	0.66	0.70	0.74
Overall Length	D	5.00 BSC		
Overall Terminal Pitch	eD	4.00 BSC		
Overall Width	E	7.00 BSC		
Overall Terminal Pitch	eE	6.50 BSC		
Ball Diameter	b	0.20	0.25	0.30

**Notes:**

1. Pin 1 visual index feature may vary, but must be located within the hatched area.
2. Dimensioning and tolerancing per ASME Y14.5M
  - BSC: Basic Dimension. Theoretically exact value shown without tolerances.
  - REF: Reference Dimension, usually without tolerance, for information purposes only.

**Footprint Outlines and Dimensions**

**22-Ball Chip Array Ball Grid Array (JY) - 5x7 mm Body [CABGA]**

**Note:** For the most current package drawings, please see the Microchip Packaging Specification located at <http://www.microchip.com/packaging>

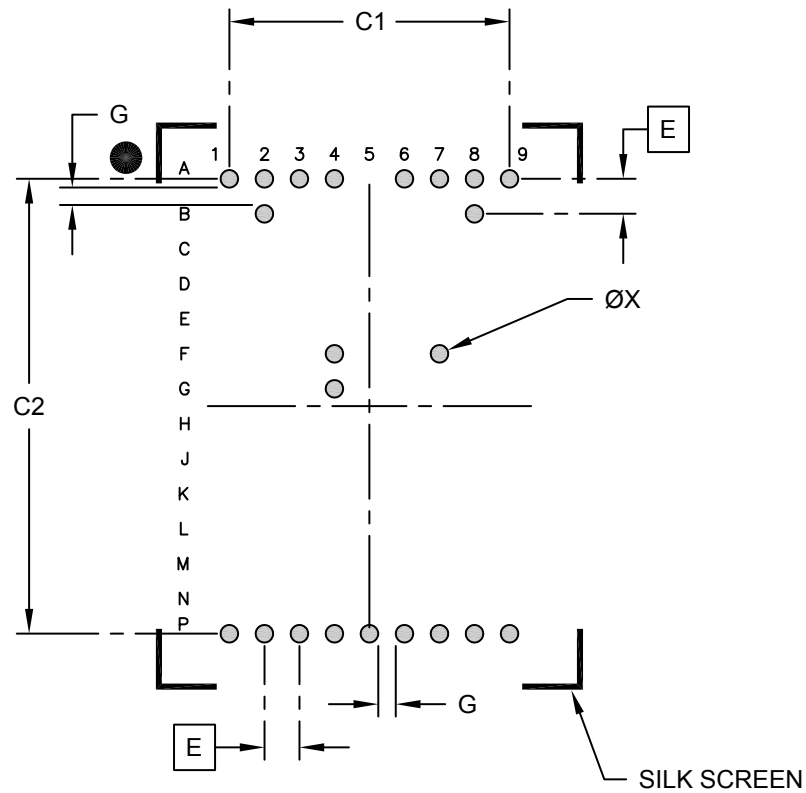

**RECOMMENDED LAND PATTERN**

Dimension Limits	Units	MILLIMETERS		
		MIN	NOM	MAX
Contact Pitch	E	0.50 BSC		
Contact Pad Spacing	C1		4.00	
Contact Pad Spacing	C2		6.50	
Contact Pad Diameter (X22)	X		0.25	
Contact Pad to Contact Pad	G	0.20		

**Notes:**

1. Dimensioning and tolerancing per ASME Y14.5M  
BSC: Basic Dimension. Theoretically exact value shown without tolerances.

---

---

**Package Outlines and Dimensions**

---

---

**TBGA**

**Package Outlines and Dimensions**

**24-Ball Thin Profile Ball Grid Array (TD) - 6x8 mm Body [TBGA]**

**Note:** For the most current package drawings, please see the Microchip Packaging Specification located at <http://www.microchip.com/packaging>

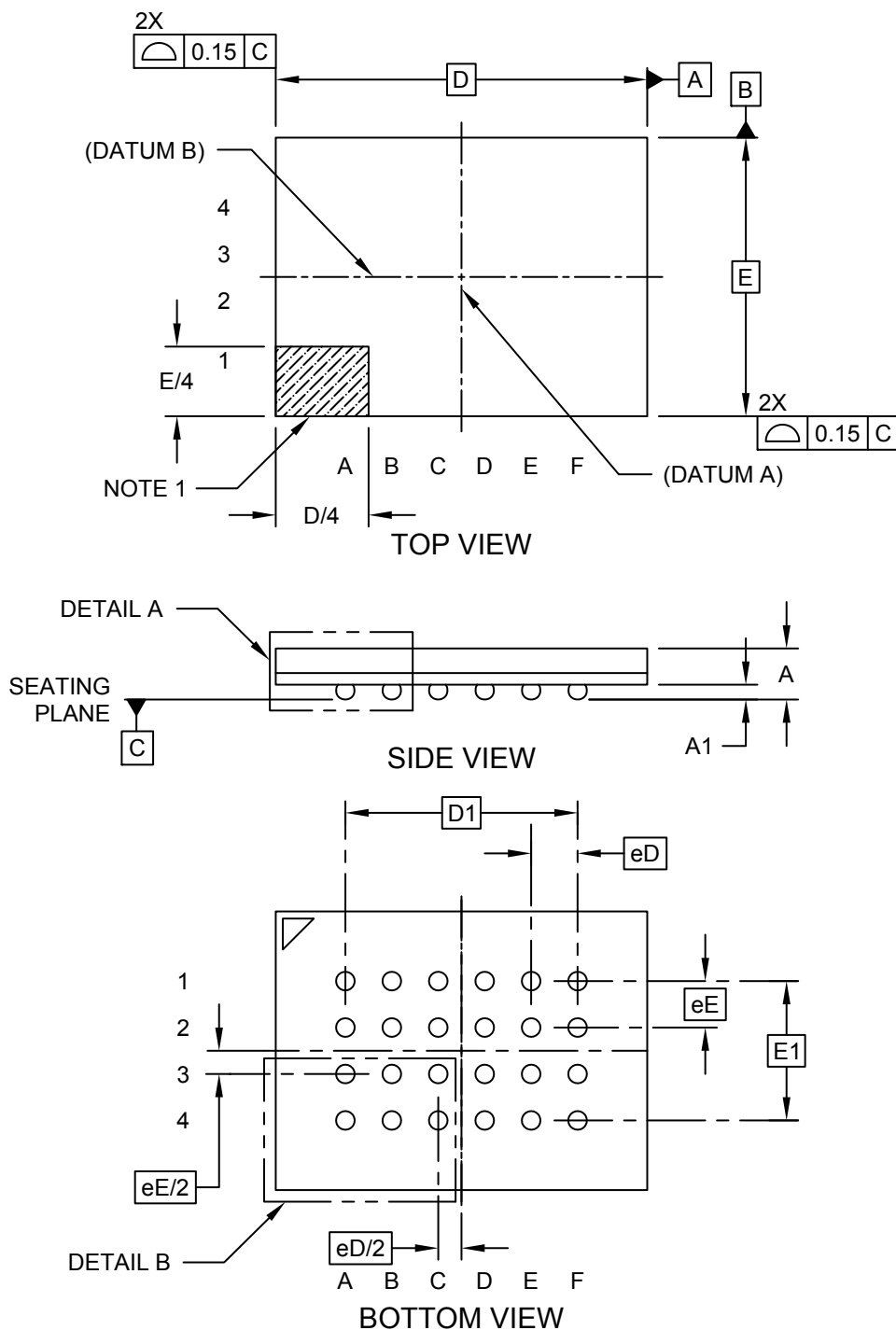



## Package Outlines and Dimensions

### 24-Ball Thin Profile Ball Grid Array (TD) - 6x8 mm Body [TBGA]

**Note:** For the most current package drawings, please see the Microchip Packaging Specification located at <http://www.microchip.com/packaging>

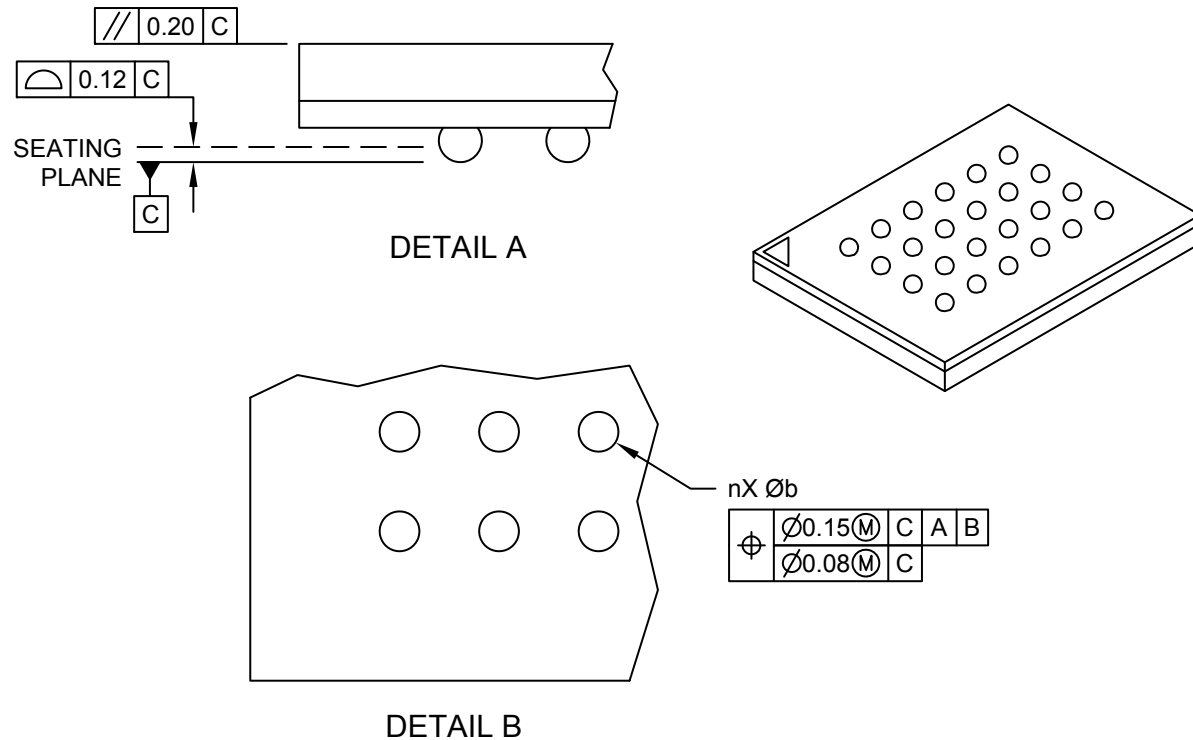

Dimension Limits	Units	MILLIMETERS		
		MIN	NOM	MAX
Number of Solder Balls	n	24		
Solder Ball X-Pitch	eD	1.00 BSC		
Solder Ball Y-Pitch	eE	1.00 BSC		
Overall Height	A	1.00	1.10	1.20
Ball Height	A1	0.27	0.32	0.37
Overall Length	D	8.00 BSC		
Overall Solder Ball Y-Pitch	D1	5.00 BSC		
Overall Width	E	6.00 BSC		
Overall Solder Ball Y-Pitch	E1	3.00 BSC		
Solder Ball Width	b	0.35	0.40	0.45

**Notes:**

1. Ball A1 visual index feature may vary, but must be located within the hatched area.
2. Dimensioning and tolerancing per ASME Y14.5M  
 BSC: Basic Dimension. Theoretically exact value shown without tolerances.  
 REF: Reference Dimension, usually without tolerance, for information purposes only.
3. Ball interface to package body: 0.32mm nominal diameter.



**MICROCHIP**

---

---

**Package Outlines and Dimensions**

---

---

NOTES:

---

---

**Package Outlines and Dimensions**

---

---

**LFBGA**

**Package Outlines and Dimensions**

**169-Ball Low Profile Ball Grid Array (6JX) - 11x11 mm Body [LFBGA]**

**Note:** For the most current package drawings, please see the Microchip Packaging Specification located at <http://www.microchip.com/packaging>

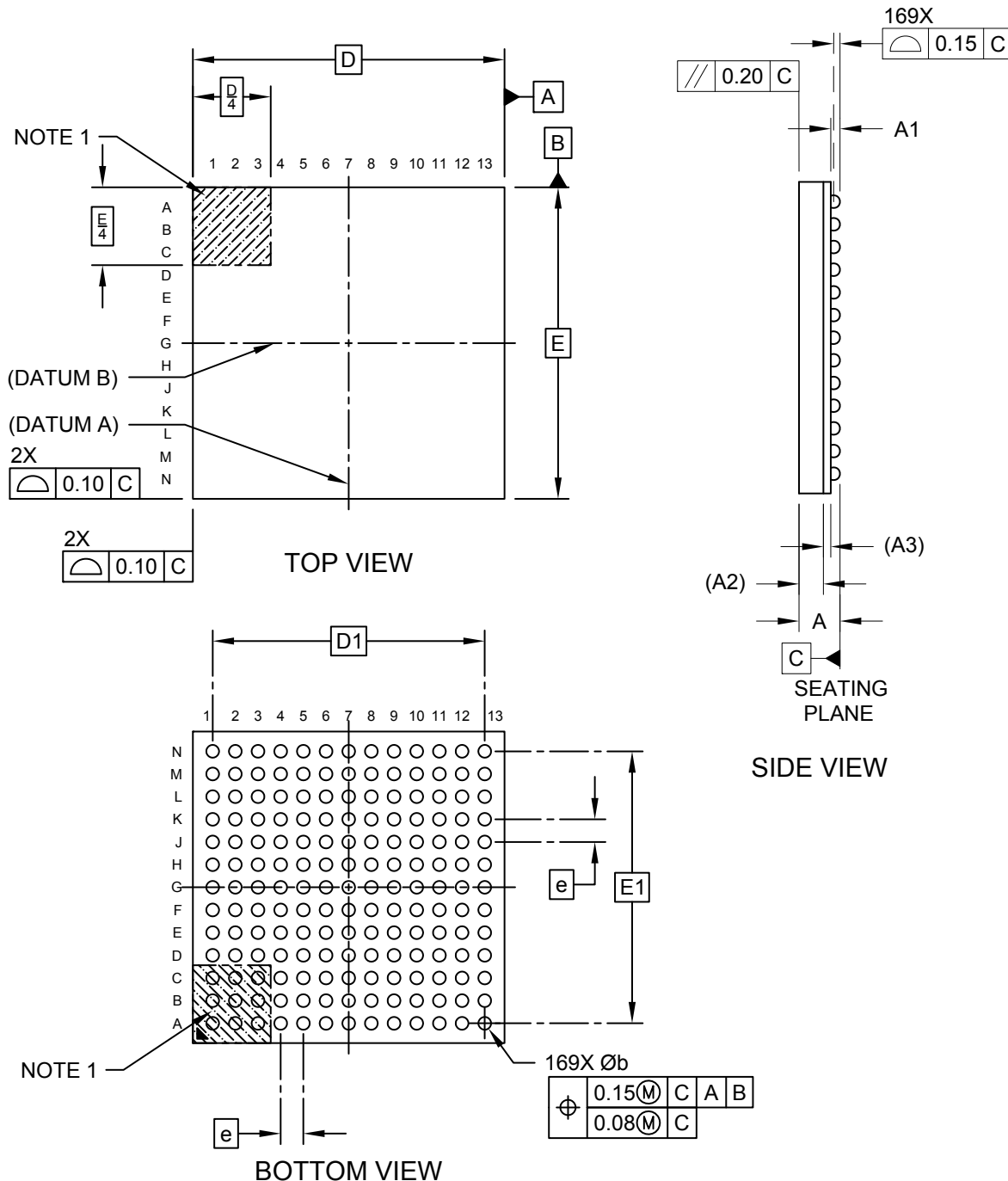

---



---

## Package Outlines and Dimensions

---



---

### 169-Ball Low Profile Ball Grid Array (6JX) - 11x11 mm Body [LFBGA]

**Note:** For the most current package drawings, please see the Microchip Packaging Specification located at <http://www.microchip.com/packaging>

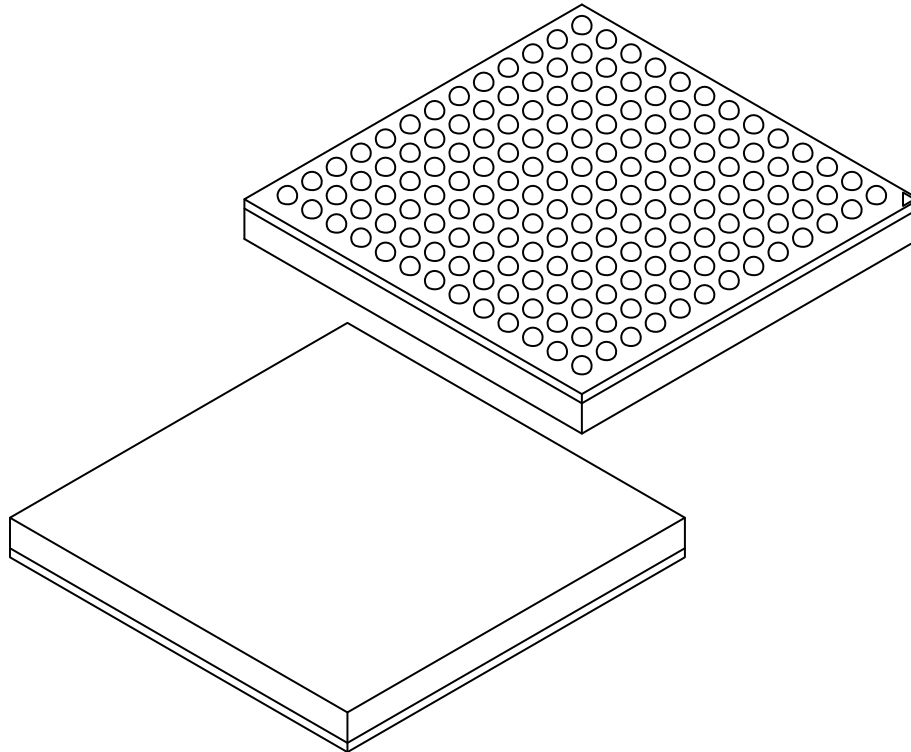

		Units	MILLIMETERS		
Dimension Limits			MIN	NOM	MAX
Number of Terminals	N		169		
Pitch	e		0.80 BSC		
Overall Height	A	1.33	1.445	1.56	
Standoff	A1	0.40	0.45	0.50	
Mold Thickness	A2	0.86 REF			
Substrate Thickness	A3	0.26 REF			
Overall Length	D	11.00 BSC			
Overall Terminal Spacing	D1	9.60 BSC			
Overall Width	E	11.00 BSC			
Overall Terminal Spacing	E1	9.60 BSC			
Terminal Diameter	b	0.40	0.45	0.50	

**Notes:**

1. Pin A1 visual index feature may vary, but must be located within the hatched area.
2. Dimensioning and tolerancing per ASME Y14.5M
  - BSC: Basic Dimension. Theoretically exact value shown without tolerances.
  - REF: Reference Dimension, usually without tolerance, for information purposes only.

**Footprint Outlines and Dimensions**

**169-Ball Low Profile Ball Grid Array (6JX) - 11x11 mm Body [LFBGA]**

**Note:** For the most current package drawings, please see the Microchip Packaging Specification located at <http://www.microchip.com/packaging>

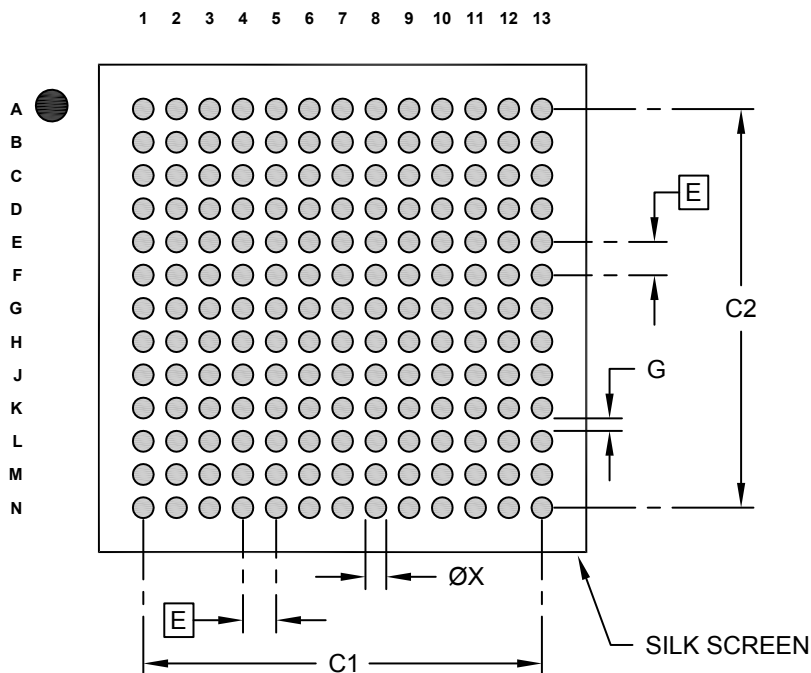

**RECOMMENDED LAND PATTERN**

		Units	MILLIMETERS		
Dimension Limits			MIN	NOM	MAX
Contact Pitch	E		0.80 BSC		
Overall Contact Pad Spacing	C1			9.60	
Overall Contact Pad Spacing	C2			9.60	
Contact Pad Width (X169)	X1				0.50
Contact Pad to Contact Pad	G	0.30			

**Notes:**

1. Dimensioning and tolerancing per ASME Y14.5M  
BSC: Basic Dimension. Theoretically exact value shown without tolerances.

**Package Outlines and Dimensions**

**169-Ball Low Profile Fine Pitch Ball Grid Array (HF) - 11x11x1.4 mm Body [LFBGA]**

**Note:** For the most current package drawings, please see the Microchip Packaging Specification located at <http://www.microchip.com/packaging>

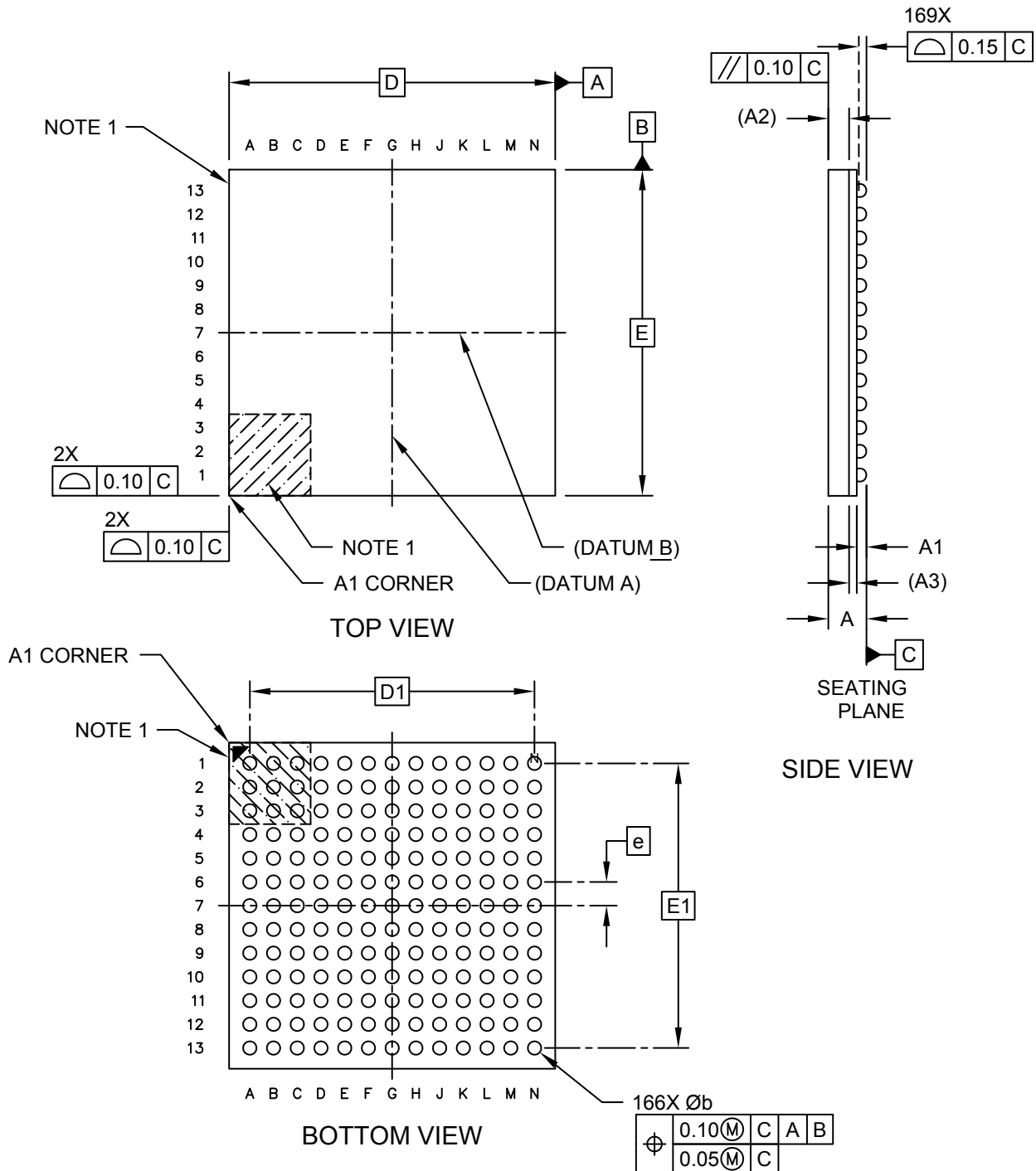

**Package Outlines and Dimensions**

**169-Ball Low Profile Fine Pitch Ball Grid Array (HF) - 11x11x1.4 mm Body [LFBGA]**

**Note:** For the most current package drawings, please see the Microchip Packaging Specification located at <http://www.microchip.com/packaging>

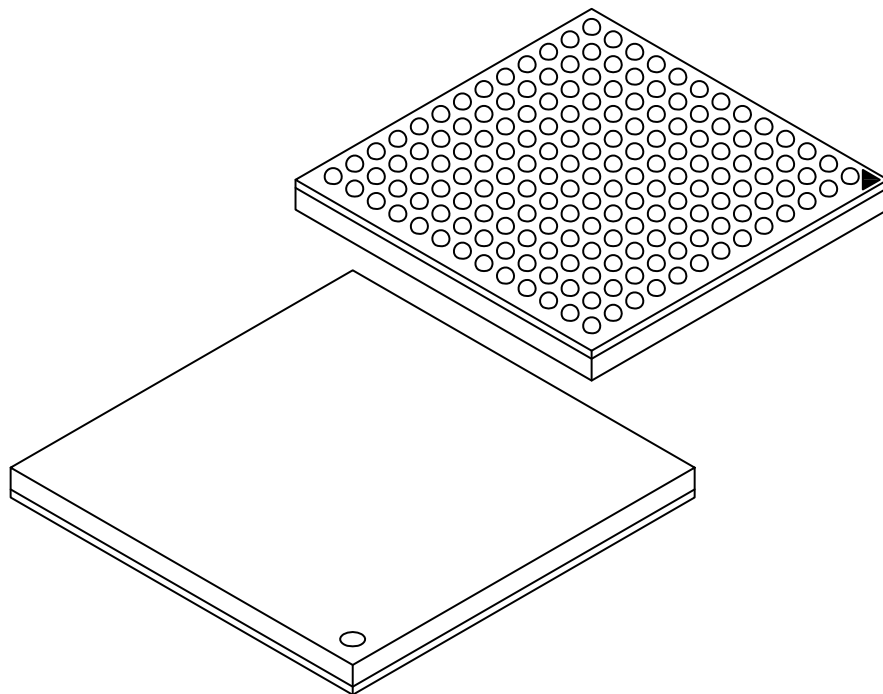

		Units	MILLIMETERS		
Dimension Limits			MIN	NOM	MAX
Number of Terminals (Balls)	N		169		
Pitch	e		0.80 BSC		
Overall Height	A	1.17	1.285	1.40	
Terminal (Ball) Height	A1	0.25	0.325	0.40	
Mold Cap Thickness	(A2)	0.70 REF			
Substrate Thickness	(A3)	0.26 REF			
Overall Length	D	11.00 BSC			
Overall Width	E	11.00 BSC			
Overall Ball Pitch	D1	9.60			
Overall Ball Pitch	E1	9.60			
Ball Diameter	b	0.40	0.45	0.50	

**Notes:**

1. Pin 1 visual index feature may vary, but must be located within the hatched area.
2. Dimensioning and tolerancing per ASME Y14.5M
  - BSC: Basic Dimension. Theoretically exact value shown without tolerances.
  - REF: Reference Dimension, usually without tolerance, for information purposes only.



---



---

## Footprint Outlines and Dimensions

---



---

### 169 Ball Low Profile Fine Pitch Ball Grid Array (HF) - 11x11x1.4 mm Body [LFBGA]

**Note:** For the most current package drawings, please see the Microchip Packaging Specification located at <http://www.microchip.com/packaging>

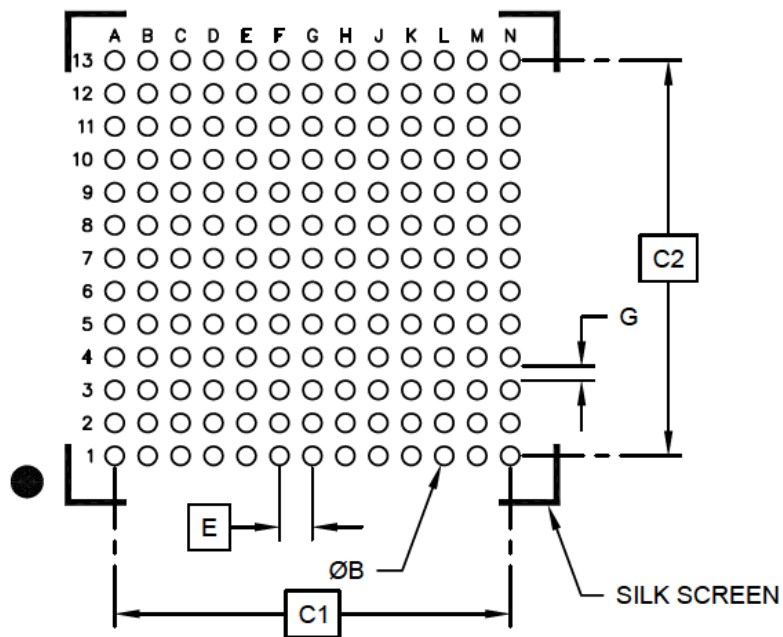

RECOMMENDED LAND PATTERN

		Units	MILLIMETERS		
		Dimension Limits	MIN	NOM	MAX
Contact Pitch	E		0.80 BSC		
Contact Pad Spacing	C1		9.60 BSC		
Contact Pad Spacing	C2		9.60 BSC		
Contact Pad Diameter (X169)	B		0.40	0.45	0.50
Pad-to-Pad Clearance	G		0.30		

**Notes:**

1. Dimensioning and tolerancing per ASME Y14.5M  
 BSC: Basic Dimension. Theoretically exact value shown without tolerances.

**Package Outlines and Dimensions**

**196-Ball Low Profile Fine Pitch Ball Grid Array (RG) - 12x12x1.4 mm Body [LFBGA]**

**Note:** For the most current package drawings, please see the Microchip Packaging Specification located at <http://www.microchip.com/packaging>

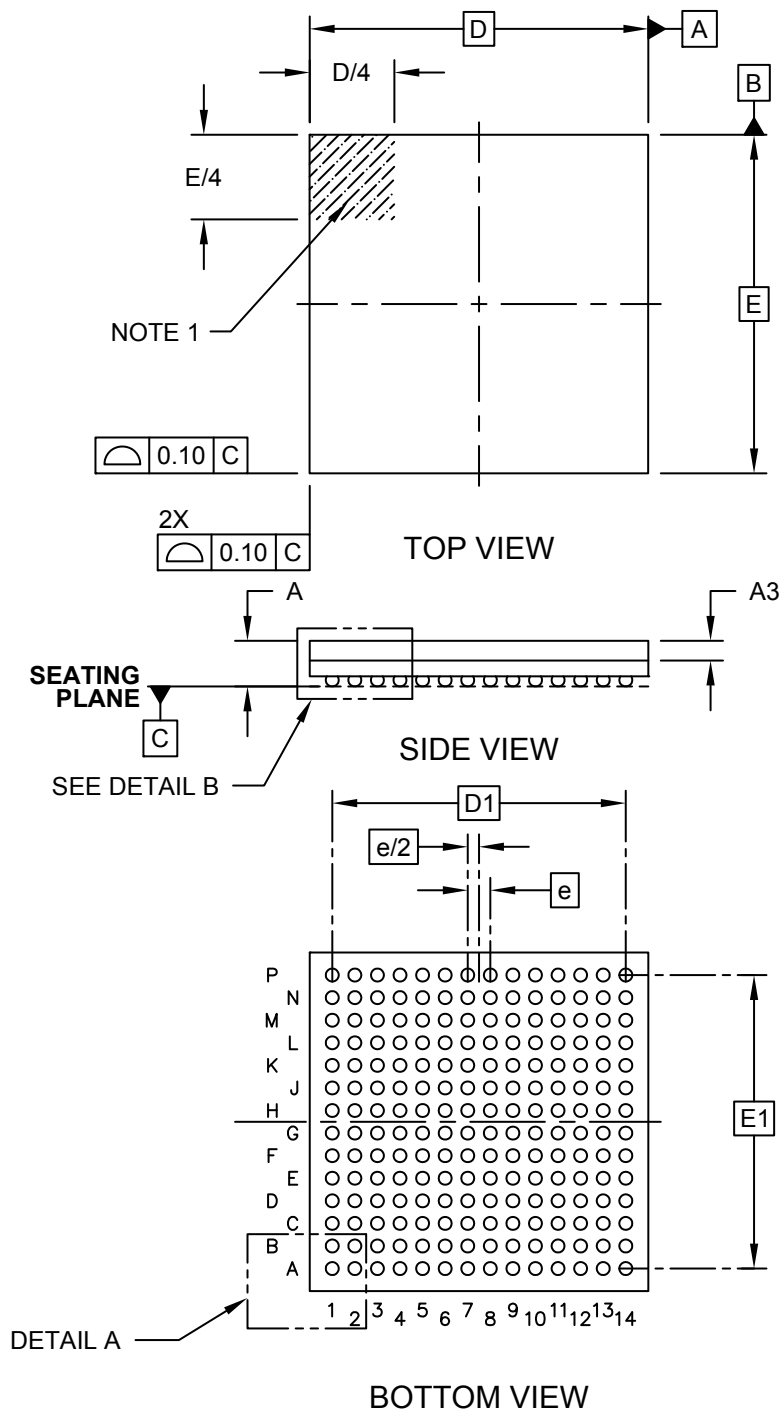

---



---

## Package Outlines and Dimensions

---



---

### 196-Ball Low Profile Fine Pitch Ball Grid Array (RG) - 12x12x1.4 mm Body [LFBGA]

**Note:** For the most current package drawings, please see the Microchip Packaging Specification located at <http://www.microchip.com/packaging>

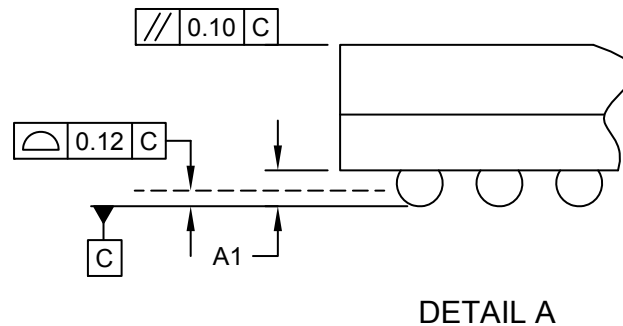
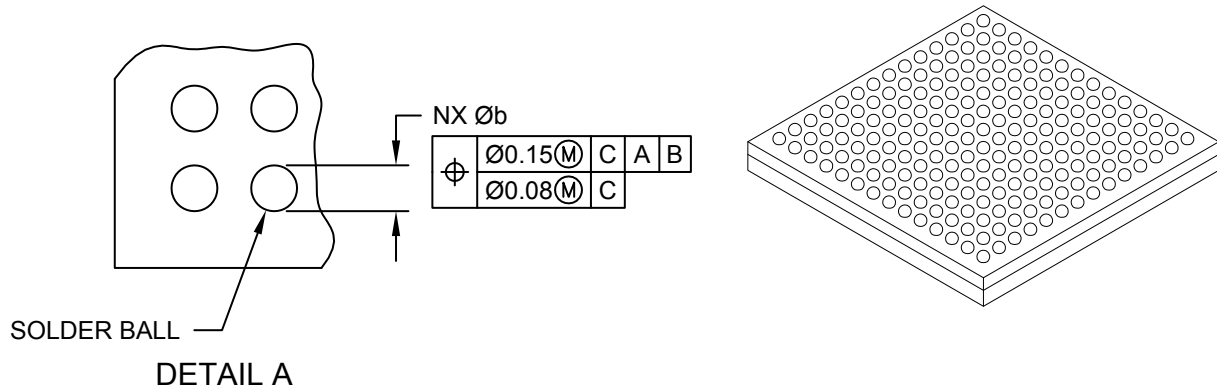

Dimension Limits	Units	MILLIMETERS		
		MIN	NOM	MAX
Number of Pins	N	196		
Pitch	e	0.80 BSC		
Overall Height	A	1.52	1.62	1.70
Standoff	A1	0.31	0.36	0.41
Molded Cap Thickness	A3	0.70 REF		
Overall Width	E	12.00 BSC		
Overall Ball Pitch	E1	10.40 BSC		
Overall Length	D	12.00 BSC		
Overall Ball Pitch	D1	10.40 BSC		
Ball Diameter	Øb	0.41	0.46	0.51

**Notes:**

1. Pin 1 visual index feature may vary, but must be located within the hatched area.
2. Dimensioning and tolerancing per ASME Y14.5M
  - BSC: Basic Dimension. Theoretically exact value shown without tolerances.
  - REF: Reference Dimension, usually without tolerance, for information purposes only.

**Footprint Outlines and Dimensions**

**196-Ball Low Profile Fine Pitch Ball Grid Array (RG) - 12x12x1.4 mm Body [LFBGA]**

**Note:** For the most current package drawings, please see the Microchip Packaging Specification located at <http://www.microchip.com/packaging>

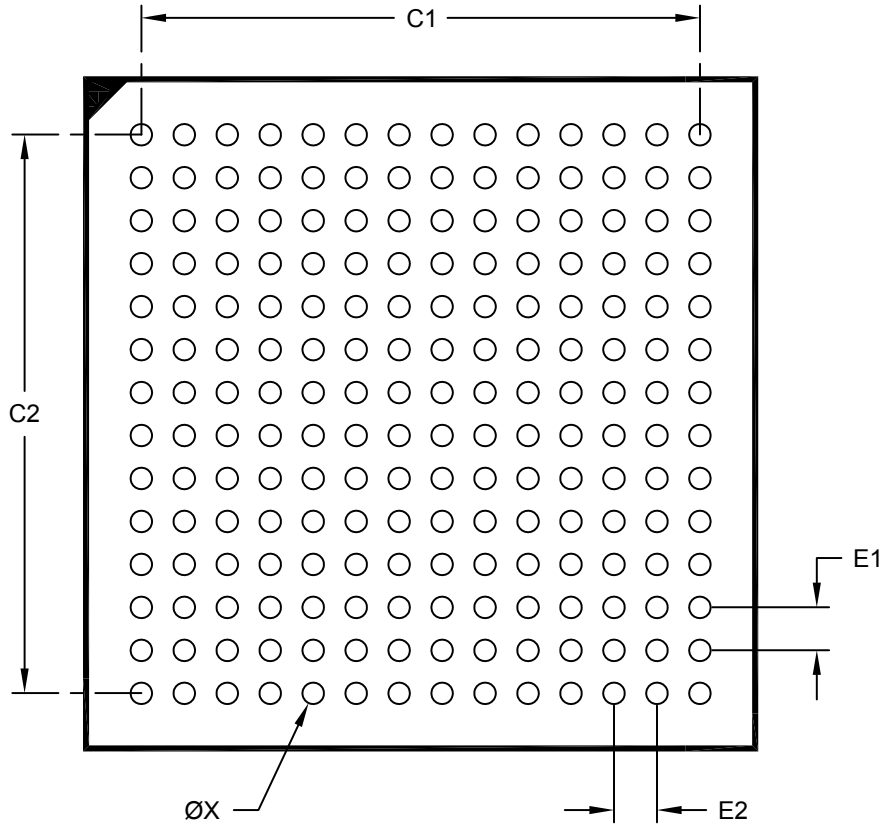

**RECOMMENDED LAND PATTERN**

		Units	MILLIMETERS		
		Dimension Limits	MIN	NOM	MAX
Contact Pitch	E1		0.80 BSC		
Contact Pitch	E2		0.80 BSC		
Contact Pad Spacing	C1			10.40	
Contact Pad Spacing	C2			10.40	
Contact Pad Diameter (X196)	X				0.40

**Notes:**

1. Dimensioning and tolerancing per ASME Y14.5M

BSC: Basic Dimension. Theoretically exact value shown without tolerances.

Microchip Technology Drawing C04-2237A

## Package Outlines and Dimensions

### 256-Ball Low Profile Fine Pitch Ball Grid Array (3J) - 14x14 mm Body [LFBGA]

**Note:** For the most current package drawings, please see the Microchip Packaging Specification located at <http://www.microchip.com/packaging>

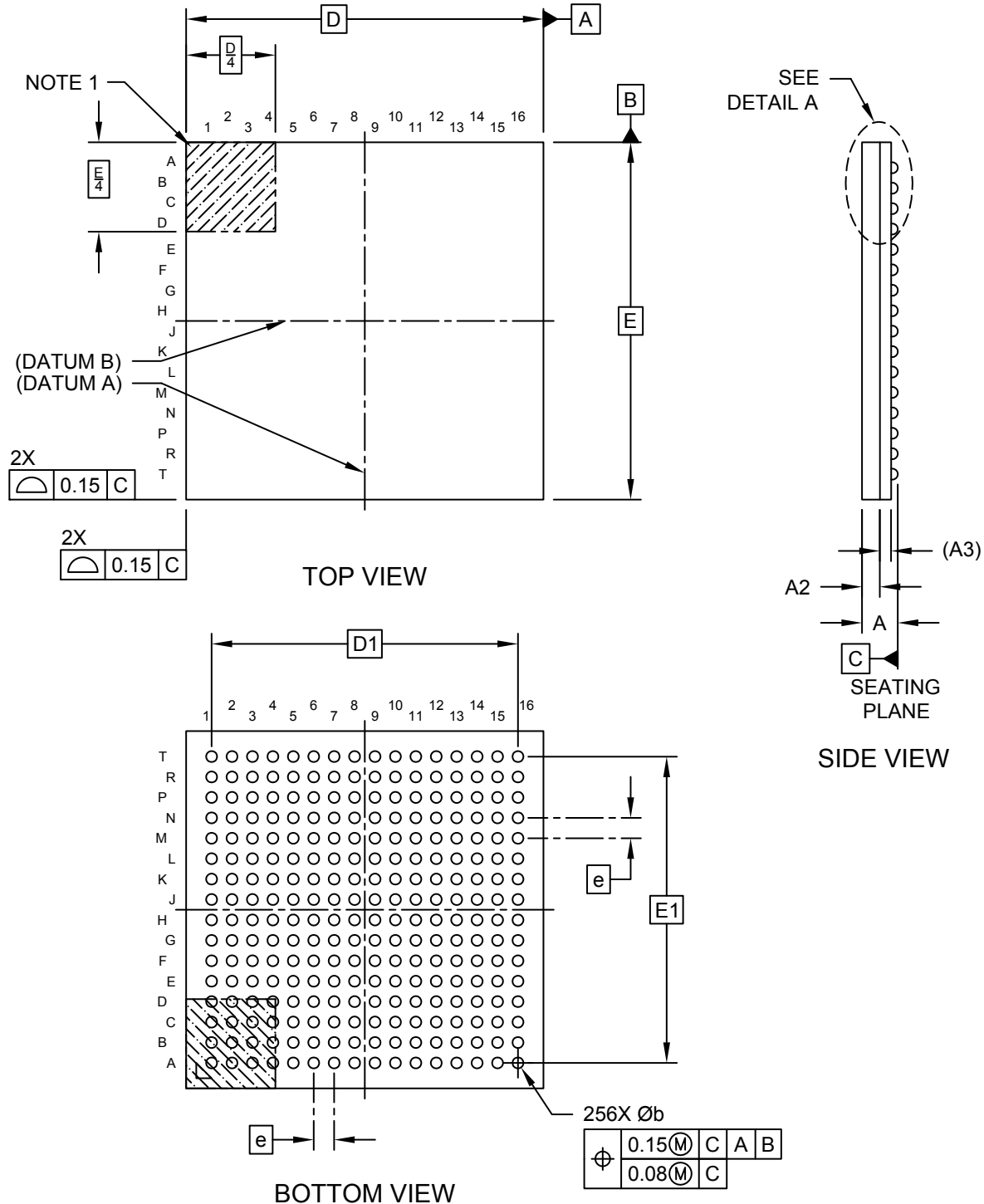

Microchip Technology Drawing C04-369A Sheet 1 of 2

## Package Outlines and Dimensions

### 256-Ball Low Profile Fine Pitch Ball Grid Array (3J) - 14x14 mm Body [LFBGA]

**Note:** For the most current package drawings, please see the Microchip Packaging Specification located at <http://www.microchip.com/packaging>

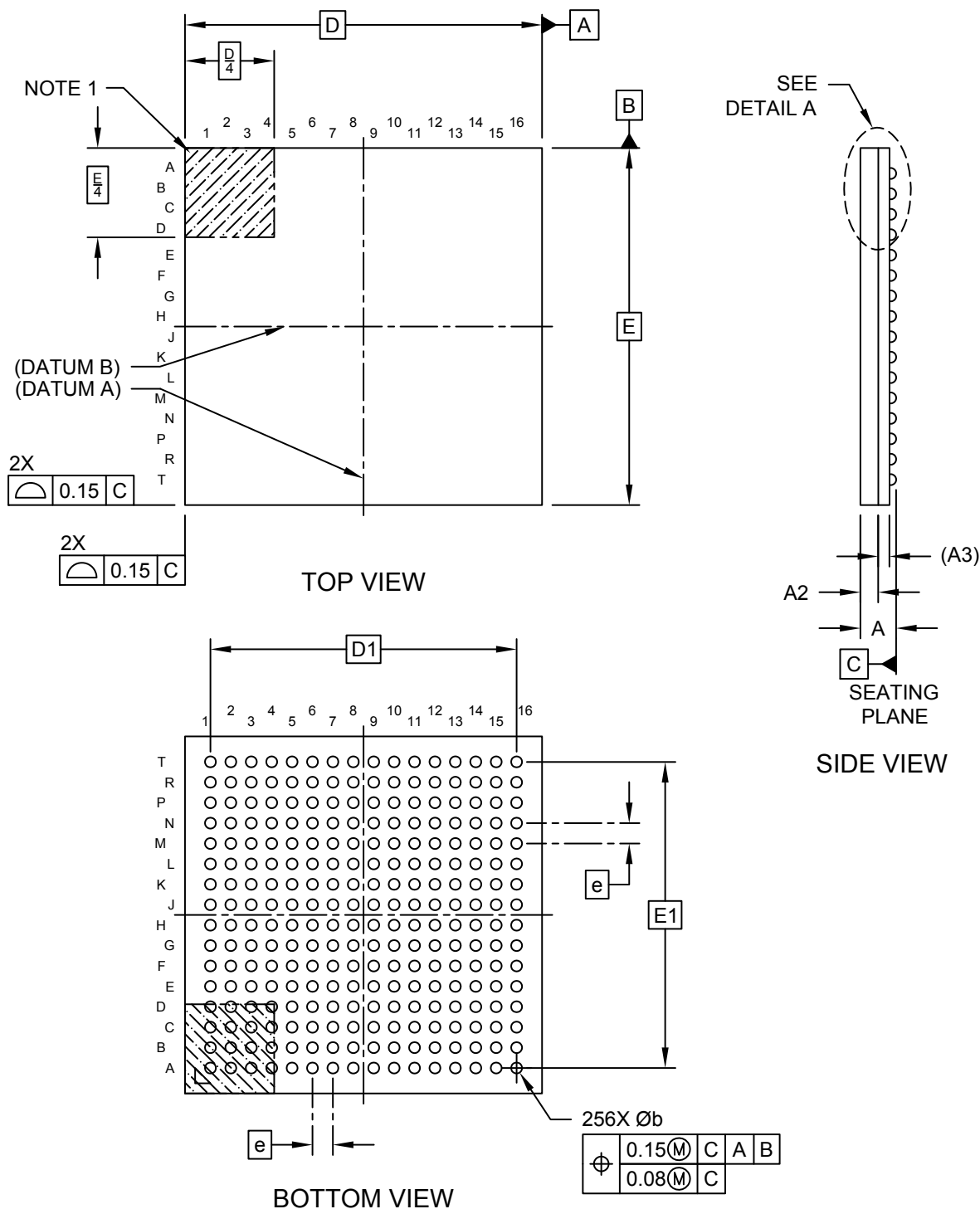

Microchip Technology Drawing C04-369A Sheet 1 of 2

---



---

## Footprint Outlines and Dimensions

---



---

### 256-Ball Low Profile Fine Pitch Ball Grid Array (3J) - 14x14 mm Body [LFBGA]

**Note:** For the most current package drawings, please see the Microchip Packaging Specification located at <http://www.microchip.com/packaging>

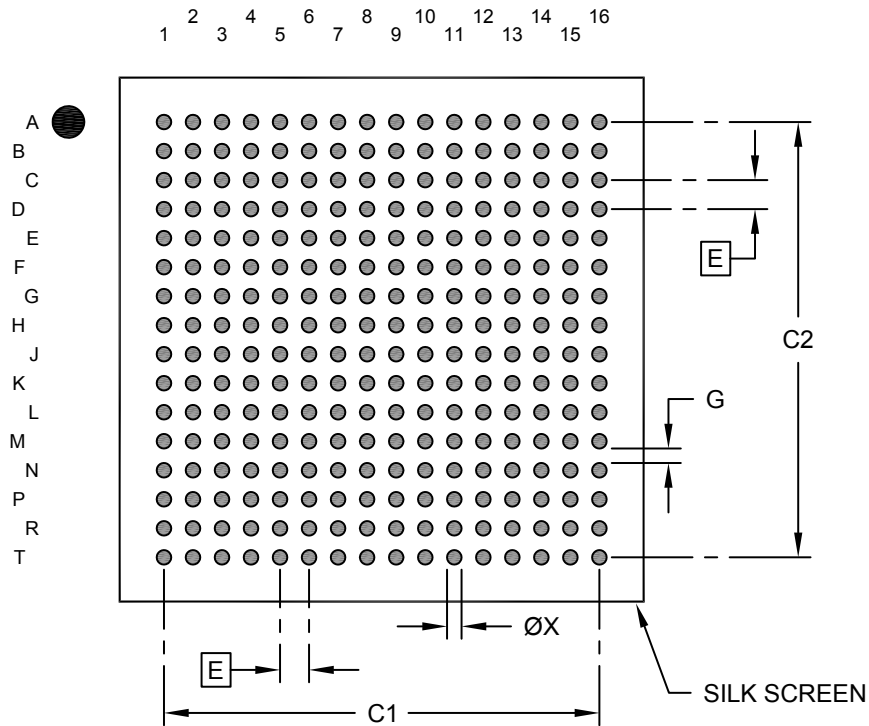

**RECOMMENDED LAND PATTERN**

		MILLIMETERS		
Units				
Dimension Limits		MIN	NOM	MAX
Contact Pitch	E	0.80 BSC		
Overall Contact Pad Spacing	C1		12.00	
Overall Contact Pad Spacing	C2		12.00	
Contact Pad Width (X256)	X1			0.43
Contact Pad to Contact Pad	G	0.40		

**Notes:**

1. Dimensioning and tolerancing per ASME Y14.5M  
 BSC: Basic Dimension. Theoretically exact value shown without tolerances.

## Package Outlines and Dimensions

### 288 Ball Low Profile Fine Pitch Ball Grid Array (4J) - 15x15x1.4 mm Body [LFBGA]

**Note:** For the most current package drawings, please see the Microchip Packaging Specification located at <http://www.microchip.com/packaging>

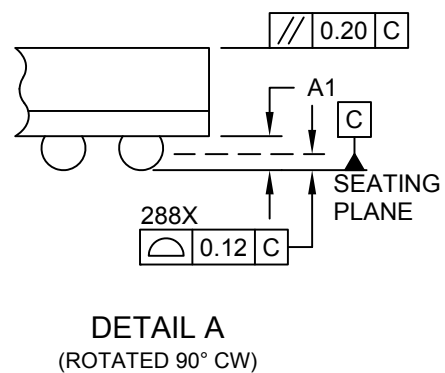
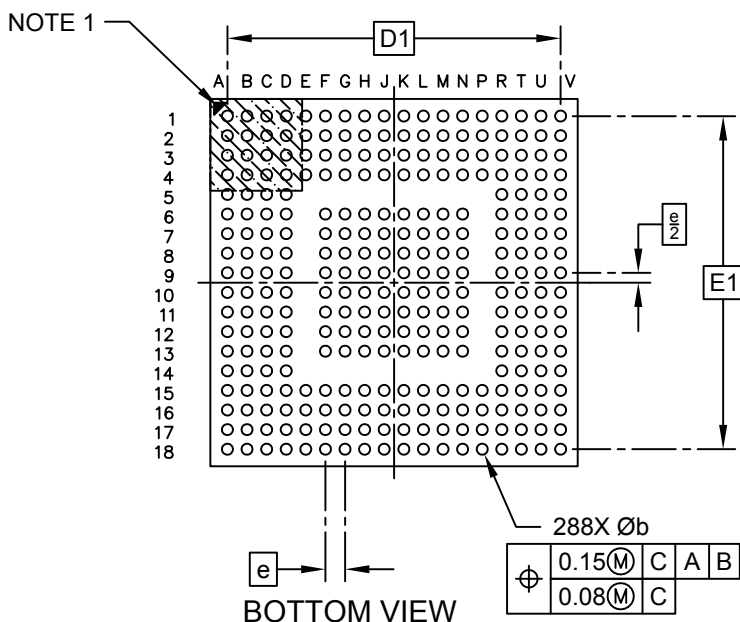
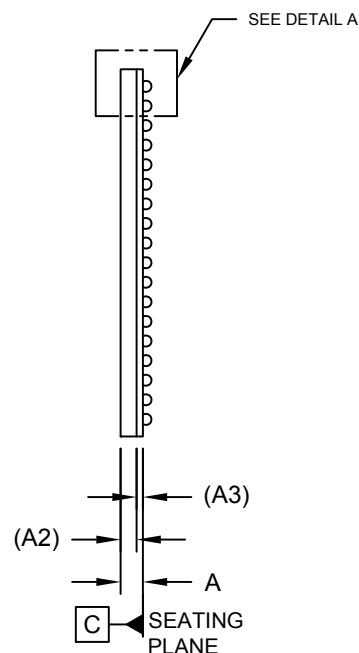
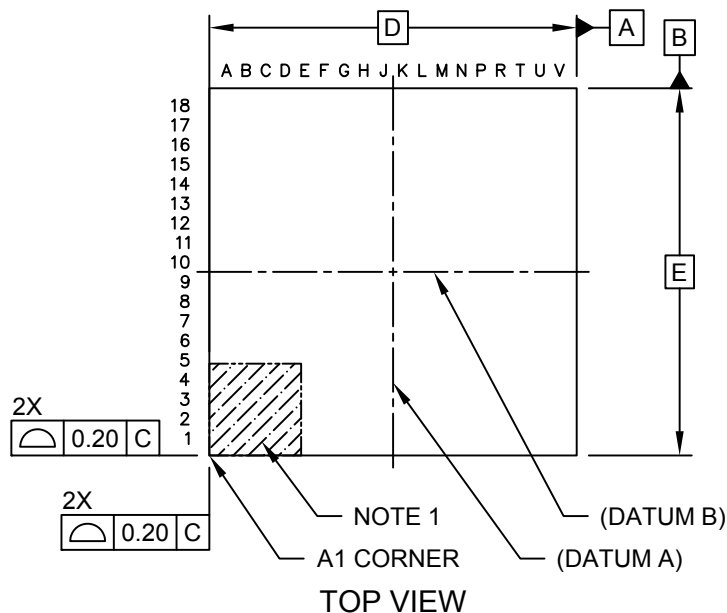



---



---

## Package Outlines and Dimensions

---



---

### 288 Ball Low Profile Fine Pitch Ball Grid Array (4J) - 15x15x1.4 mm Body [LFBGA]

**Note:** For the most current package drawings, please see the Microchip Packaging Specification located at <http://www.microchip.com/packaging>

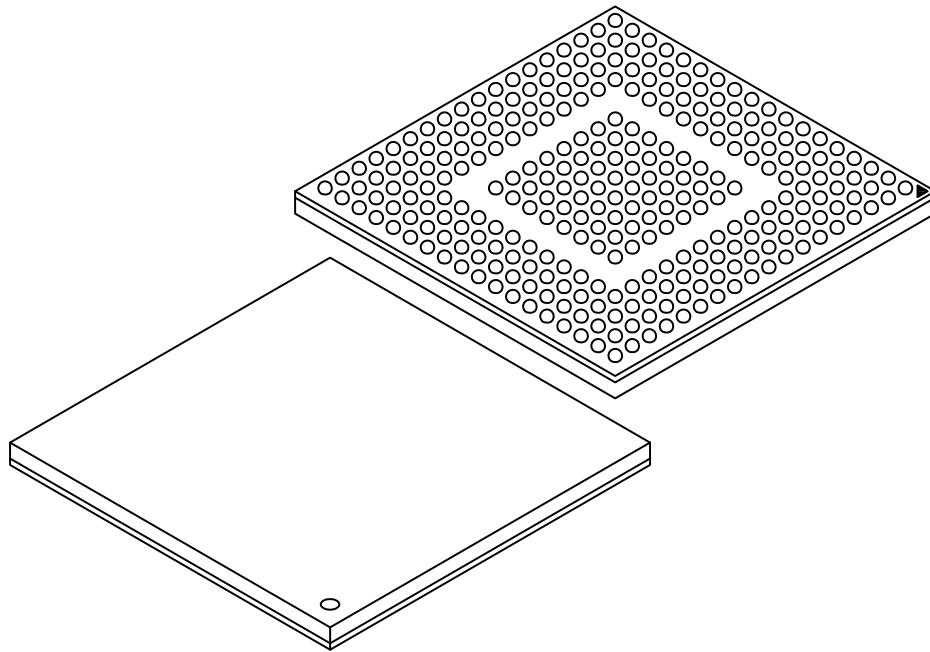

		MILLIMETERS		
Units				
Dimension Limits		MIN	NOM	MAX
Number of Terminals (Balls)	N	288		
Pitch	e	0.80 BSC		
Overall Height	A	-	-	1.40
Terminal (Ball) Height	A1	0.30	0.35	0.40
Mold Cap Height	(A2)	0.70 REF		
Substrate Thickness	(A3)	0.26 REF		
Overall Length	D	15.00 BSC		
Overall Ball Pitch	D1	13.60 BSC		
Overall Width	E	15.00 BSC		
Overall Ball Pitch	E1	13.60 BSC		
Ball Diameter	b	0.40	0.45	0.50

**Notes:**

1. Pin 1 visual index feature may vary, but must be located within the hatched area.
2. Dimensioning and tolerancing per ASME Y14.5M
  - BSC: Basic Dimension. Theoretically exact value shown without tolerances.
  - REF: Reference Dimension, usually without tolerance, for information purposes only.

**Footprint Outlines and Dimensions**

**288 Ball Low Profile Fine Pitch Ball Grid Array (4J) - 15x15x1.4 mm Body [LFBGA]**

**Note:** For the most current package drawings, please see the Microchip Packaging Specification located at <http://www.microchip.com/packaging>

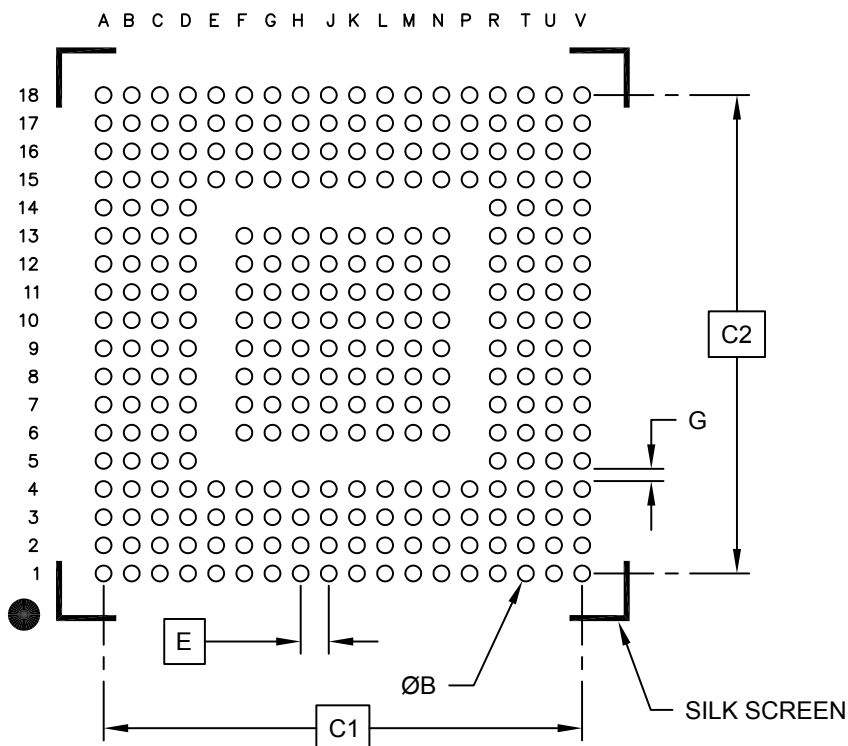

**RECOMMENDED LAND PATTERN**

	Units	MILLIMETERS		
		MIN	NOM	MAX
Contact Pitch	E	0.80 BSC		
Contact Pad Spacing	C1	13.60 BSC		
Contact Pad Spacing	C2	13.60 BSC		
Contact Pad Diameter (X288)	B	0.40	0.45	0.50
Pad-to-Pad Clearance	G	0.30		

**Notes:**

1. Dimensioning and tolerancing per ASME Y14.5M  
BSC: Basic Dimension. Theoretically exact value shown without tolerances.

---

---

**Package Outlines and Dimensions**

---

---

**TFBGA**

**Package Outlines and Dimensions**

**48-Ball Thin Profile Fine Pitch Ball Grid Array (CD) - 6x8 mm Body [TFBGA]**

**Note:** For the most current package drawings, please see the Microchip Packaging Specification located at <http://www.microchip.com/packaging>

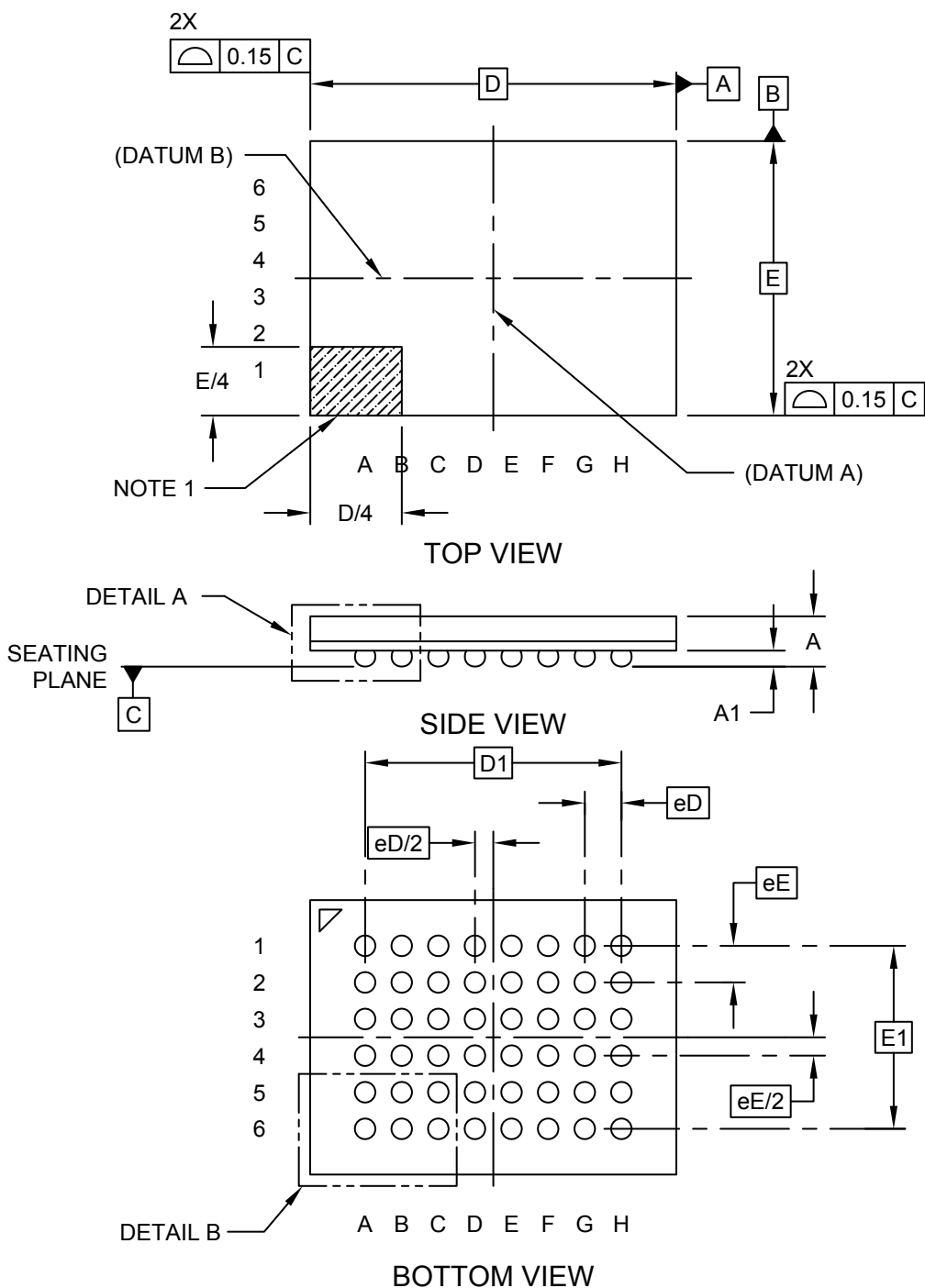

---



---

## Package Outlines and Dimensions

---



---

### 48-Ball Thin Profile Fine Pitch Ball Grid Array (CD) - 6x8 mm Body [TFBGA]

**Note:** For the most current package drawings, please see the Microchip Packaging Specification located at <http://www.microchip.com/packaging>

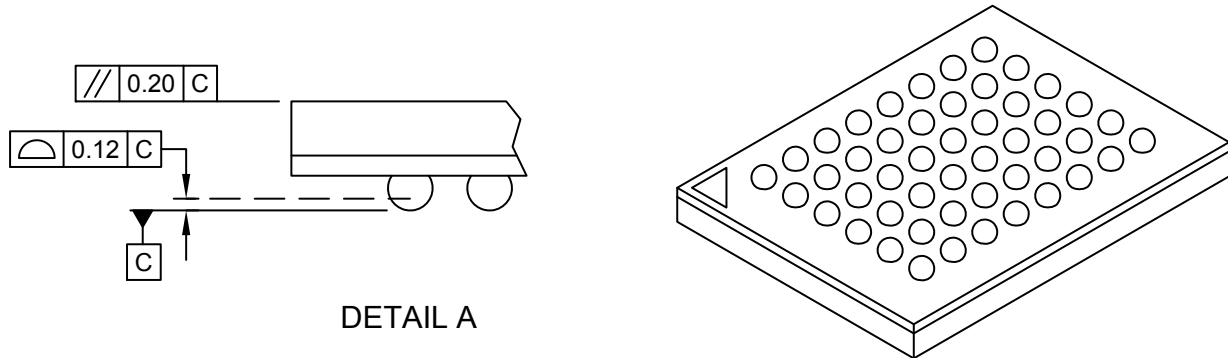

DETAIL A

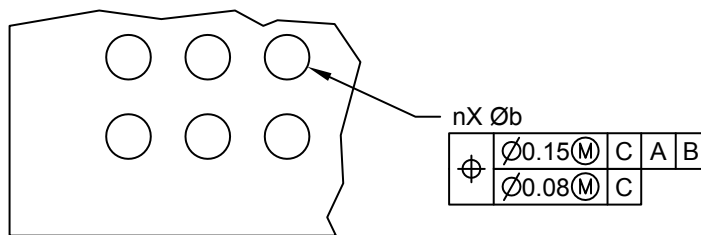

DETAIL B

		Units	MILLIMETERS		
Dimension Limits			MIN	NOM	MAX
Number of Solder Balls	n		48		
Solder Ball X-Pitch	eD		0.80 BSC		
Solder Ball Y-Pitch	eE		0.80 BSC		
Overall Height	A		1.00	1.10	1.20
Ball Height	A1		0.30	0.35	0.40
Overall Length	D		8.00 BSC		
Overall Solder Ball X-Pitch	D1		5.60 BSC		
Overall Width	E		6.00 BSC		
Overall Solder Ball Y-Pitch	E1		4.00 BSC		
Solder Ball Diameter	b		0.40	0.45	0.50

**Notes:**

1. Ball A1 visual index feature may vary, but must be located within the hatched area.
2. Dimensioning and tolerancing per ASME Y14.5M

BSC: Basic Dimension. Theoretically exact value shown without tolerances.

REF: Reference Dimension, usually without tolerance, for information purposes only.

3. Ball interface to package body: 0.38mm nominal diameter.

**Package Outlines and Dimensions**

**84-Ball Thin Fine Pitch Ball Grid Array (GQ) - 6x6 mm Body [TFBGA]**

**Note:** For the most current package drawings, please see the Microchip Packaging Specification located at <http://www.microchip.com/packaging>

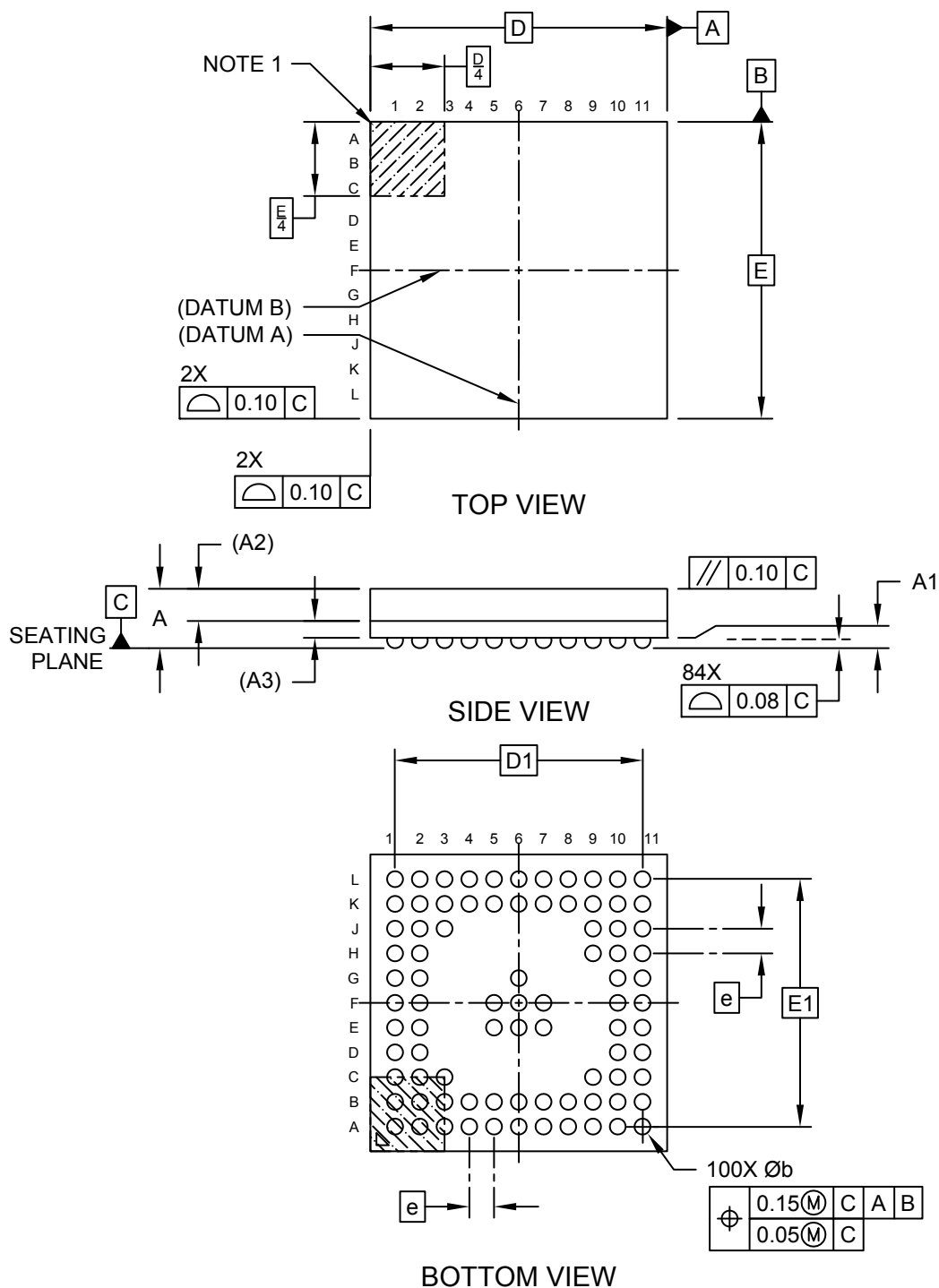

---



---

## Package Outlines and Dimensions

---



---

### 84-Ball Thin Fine Pitch Ball Grid Array (GQ) - 6x6 mm Body [TFBGA]

**Note:** For the most current package drawings, please see the Microchip Packaging Specification located at <http://www.microchip.com/packaging>

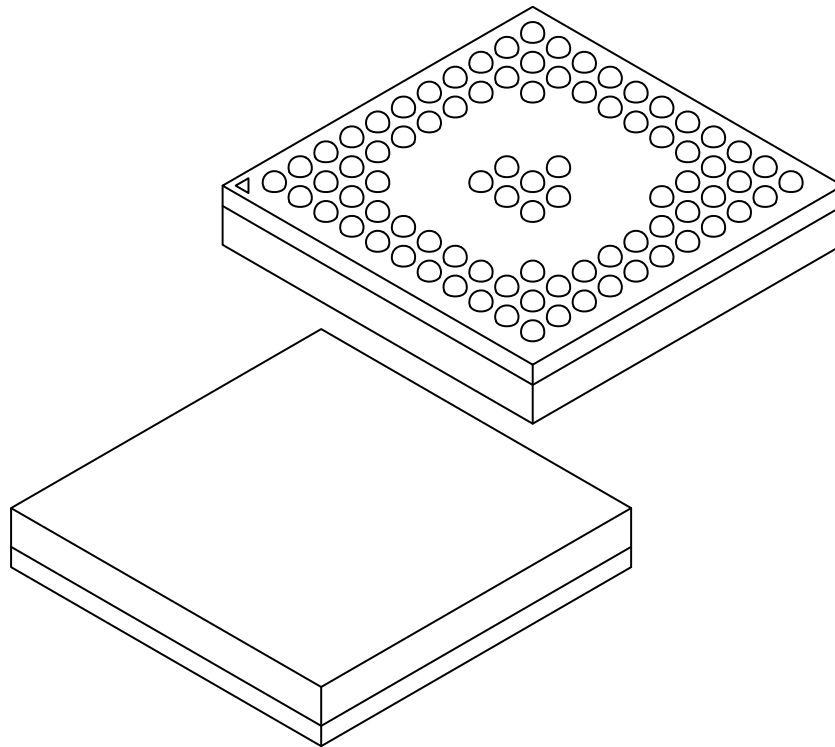

Dimension Limits	Units	MILLIMETERS		
		MIN	NOM	MAX
Number of Terminals	N	84		
Pitch	e	0.50		
Overall Height	A	-	-	1.20
Standoff	A1	0.16	0.21	0.26
Mold Thickness	A2	0.65 REF		
Substrate Thickness	A3	0.26 REF		
Overall Length	D	6.00 BSC		
Overall Terminal Spacing	D1	5.00 BSC		
Overall Width	E	6.00 BSC		
Overall Terminal Spacing	E1	5.00 BSC		
Terminal Diameter	b	0.27	0.32	0.37

**Notes:**

1. Pin 1 visual index feature may vary, but must be located within the hatched area.
2. Dimensioning and tolerancing per ASME Y14.5M
  - BSC: Basic Dimension. Theoretically exact value shown without tolerances.
  - REF: Reference Dimension, usually without tolerance, for information purposes only.

**Footprint Outlines and Dimensions**

**84-Ball Thin Fine Pitch Ball Grid Array (GQ) - 6x6 mm Body [TFBGA]**

**Note:** For the most current package drawings, please see the Microchip Packaging Specification located at <http://www.microchip.com/packaging>

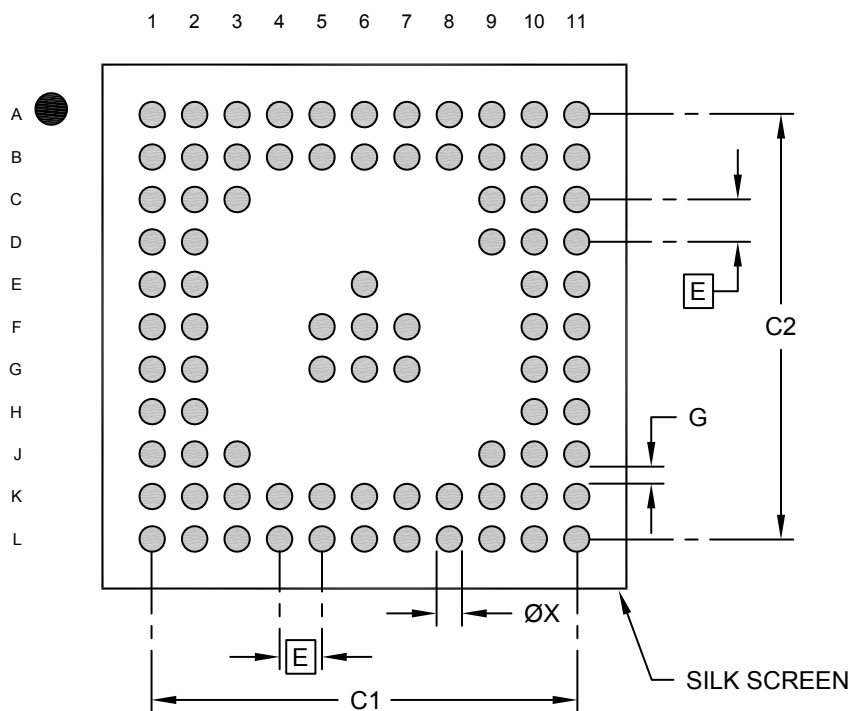

**RECOMMENDED LAND PATTERN**

Dimension Limits	Units	MILLIMETERS		
		MIN	NOM	MAX
Contact Pitch	E	0.50 BSC		
Overall Contact Pad Spacing	C1		5.00	
Overall Contact Pad Spacing	C2		5.00	
Contact Pad Width (X84)	X1			0.30
Contact Pad to Contact Pad	G	0.20		

**Notes:**

1. Dimensioning and tolerancing per ASME Y14.5M  
BSC: Basic Dimension. Theoretically exact value shown without tolerances.



## Package Outlines and Dimensions

### 100-Ball Thin Fine Pitch Ball Grid Array (GJX) - 7x7 mm Body [TFBGA]

**Note:** For the most current package drawings, please see the Microchip Packaging Specification located at <http://www.microchip.com/packaging>

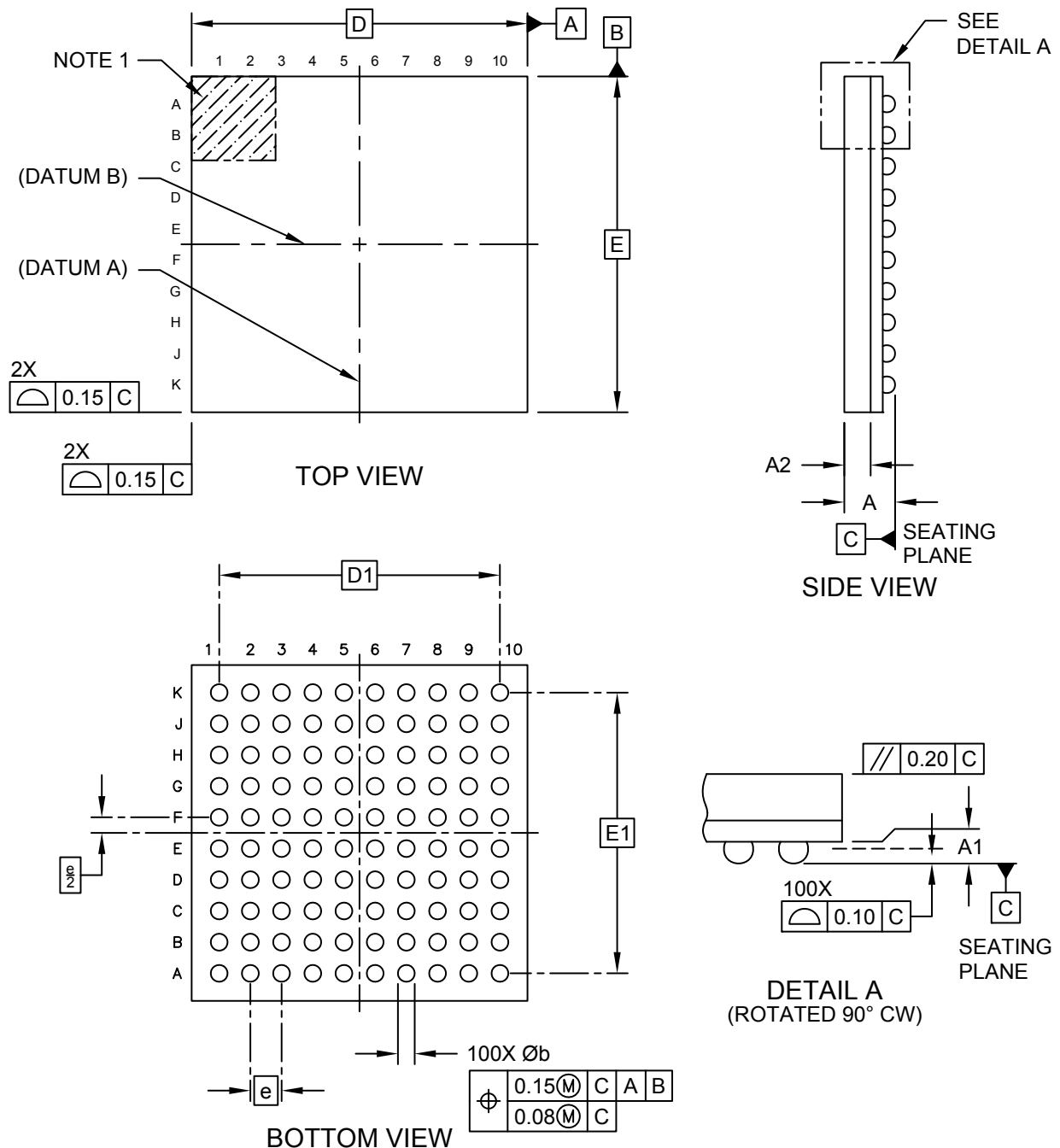

**Package Outlines and Dimensions**

**100-Ball Thin Fine Pitch Ball Grid Array (GJX) - 7x7 mm Body [TFBGA]**

**Note:** For the most current package drawings, please see the Microchip Packaging Specification located at <http://www.microchip.com/packaging>

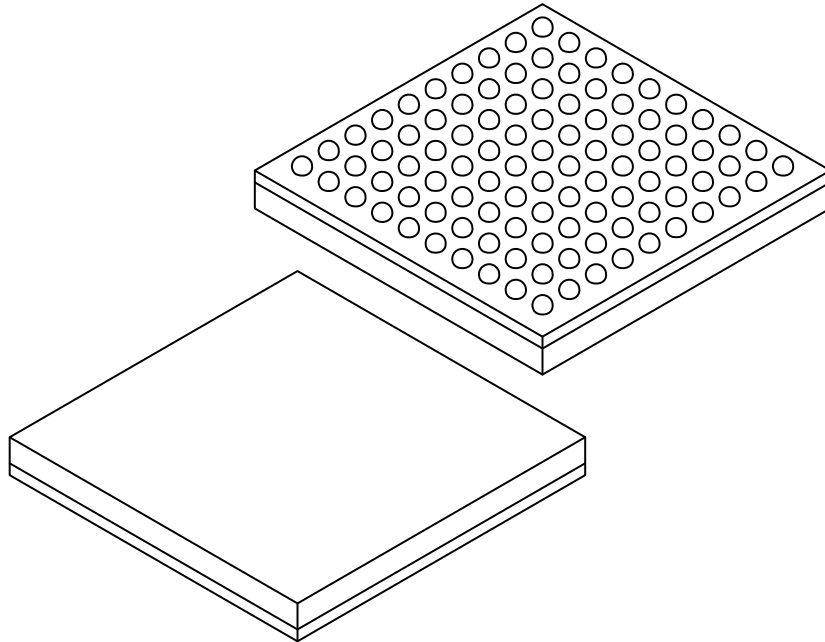

		Units	MILLIMETERS		
Dimension Limits			MIN	NOM	MAX
Number of Terminals	N		100		
Pitch	e		0.65 BSC		
Overall Height	A	-	-		1.06
Ball Height	A1	0.18	0.26		-
Mold Cap Height	A2	0.45	0.50		0.55
Overall Length	D		7.00 BSC		
Overall Pitch	D1		5.85 BSC		
Overall Width	E		7.00 BSC		
Overall Pitch	E1		5.85 BSC		
Terminal Width	b	0.30	0.35		0.40

**Notes:**

1. Pin 1 visual index feature may vary, but must be located within the hatched area.
2. Dimensioning and tolerancing per ASME Y14.5M

BSC: Basic Dimension. Theoretically exact value shown without tolerances.

REF: Reference Dimension, usually without tolerance, for information purposes only.

---



---

## Footprint Outlines and Dimensions

---



---

### 100-Ball Thin Fine Pitch Ball Grid Array (GJX) - 7x7 mm Body [TFBGA]

**Note:** For the most current package drawings, please see the Microchip Packaging Specification located at <http://www.microchip.com/packaging>

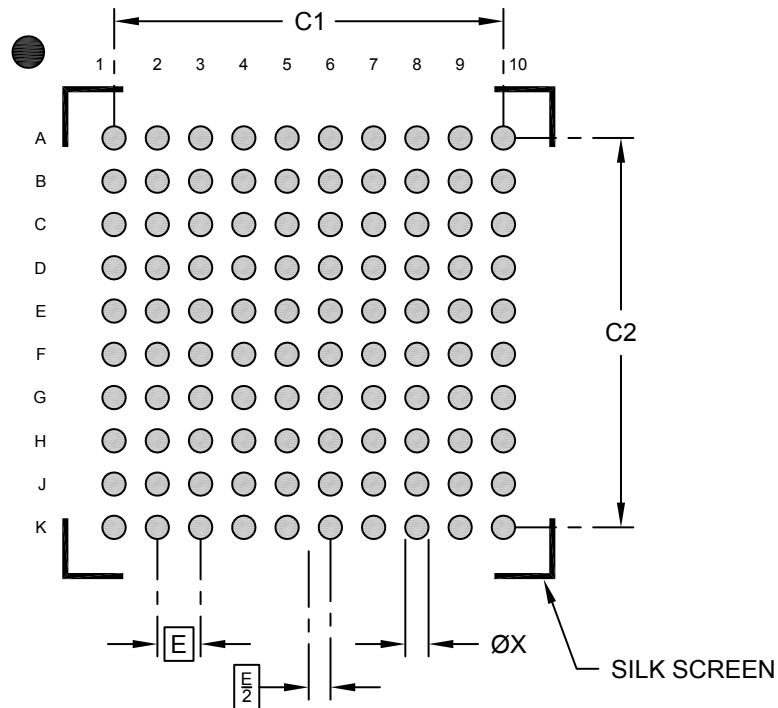

RECOMMENDED LAND PATTERN

Dimension Limits	Units	MILLIMETERS		
		MIN	NOM	MAX
Contact Pitch	E	0.65 BSC		
Contact Pad Diameter	X		0.35	
Contact Pad Spacing	C1		5.85	
Contact Pad Spacing	C2		5.85	

**Notes:**

1. Dimensioning and tolerancing per ASME Y14.5M  
BSC: Basic Dimension. Theoretically exact value shown without tolerances.

## Package Outlines and Dimensions

### 100-Ball Thin Fine Pitch Ball Grid Array (GJ) - 7x7 mm Body [TFBGA]

**Note:** For the most current package drawings, please see the Microchip Packaging Specification located at <http://www.microchip.com/packaging>

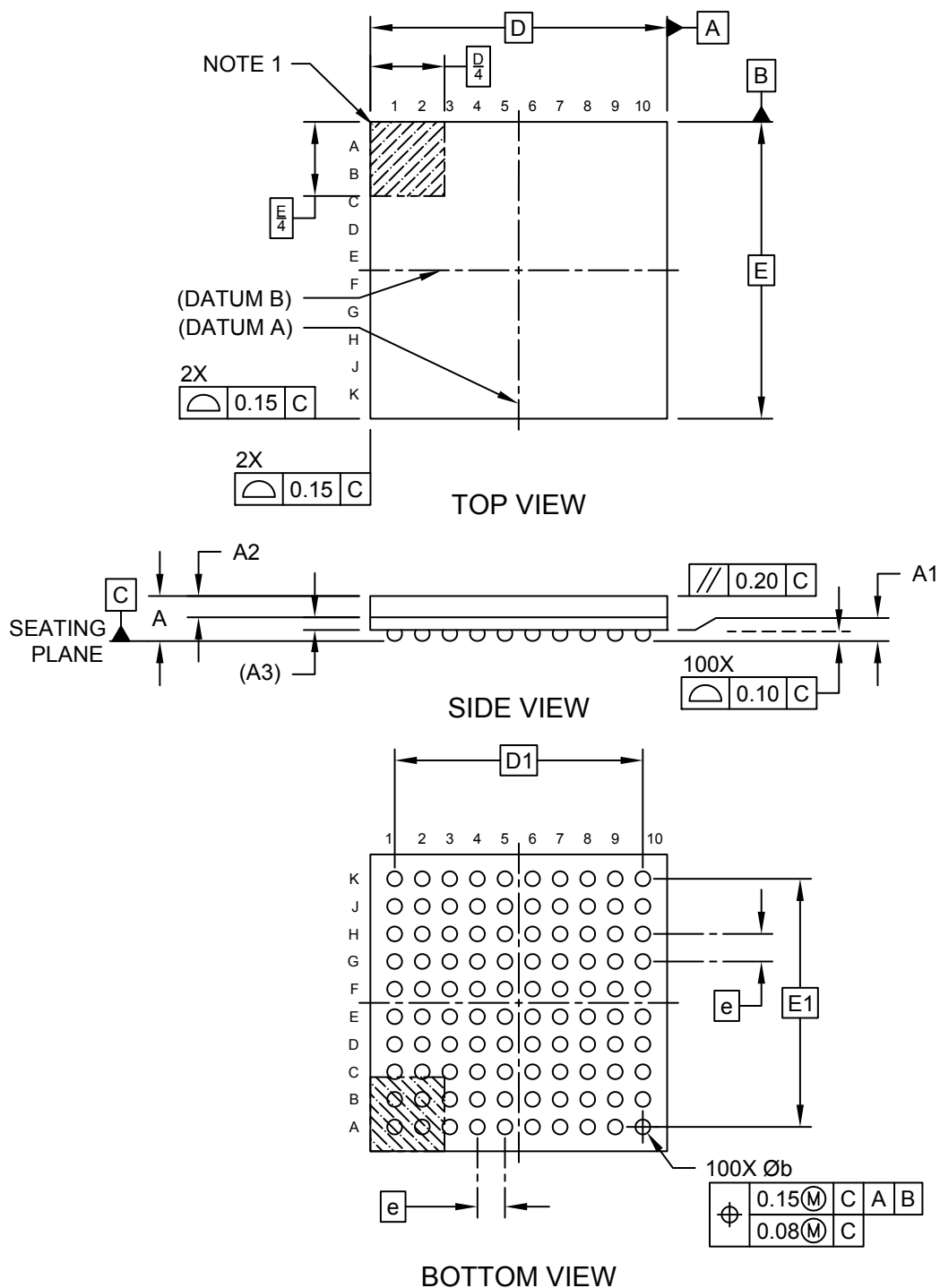

Microchip Technology Drawing C04-320A Sheet 1 of 2

---



---

## Package Outlines and Dimensions

---



---

### 100-Ball Thin Fine Pitch Ball Grid Array (GJ) - 7x7 mm Body [TFBGA]

**Note:** For the most current package drawings, please see the Microchip Packaging Specification located at <http://www.microchip.com/packaging>

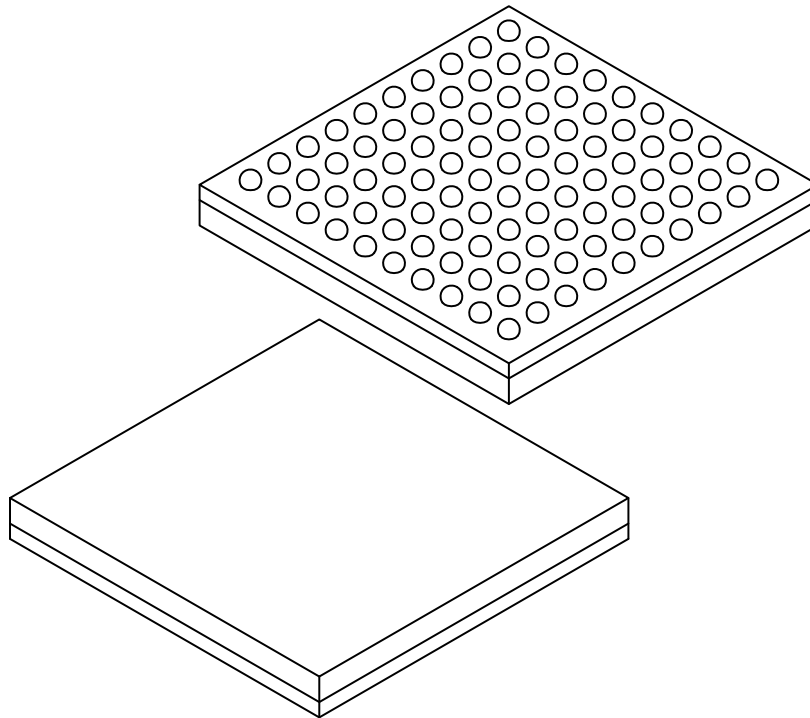

Dimension Limits	Units	MILLIMETERS		
		MIN	NOM	MAX
Number of Terminals	N	100		
Pitch	e	0.65 BSC		
Overall Height	A	-	-	1.06
Standoff	A1	0.18	0.26	-
Mold Thickness	A2	0.45	0.50	0.55
Substrate Thickness	A3	0.30 REF		
Overall Length	D	7.00 BSC		
Overall Terminal Spacing	D1	5.85 BSC		
Overall Width	E	7.00 BSC		
Overall Terminal Spacing	E1	5.85 BSC		
Terminal Diameter	b	0.30	0.35	0.40

**Notes:**

1. Pin 1 visual index feature may vary, but must be located within the hatched area.
2. Dimensioning and tolerancing per ASME Y14.5M
  - BSC: Basic Dimension. Theoretically exact value shown without tolerances.
  - REF: Reference Dimension, usually without tolerance, for information purposes only.

**Footprint Outlines and Dimensions**

**100-Ball Thin Fine Pitch Ball Grid Array (GJ) - 7x7 mm Body [TFBGA]**

**Note:** For the most current package drawings, please see the Microchip Packaging Specification located at <http://www.microchip.com/packaging>

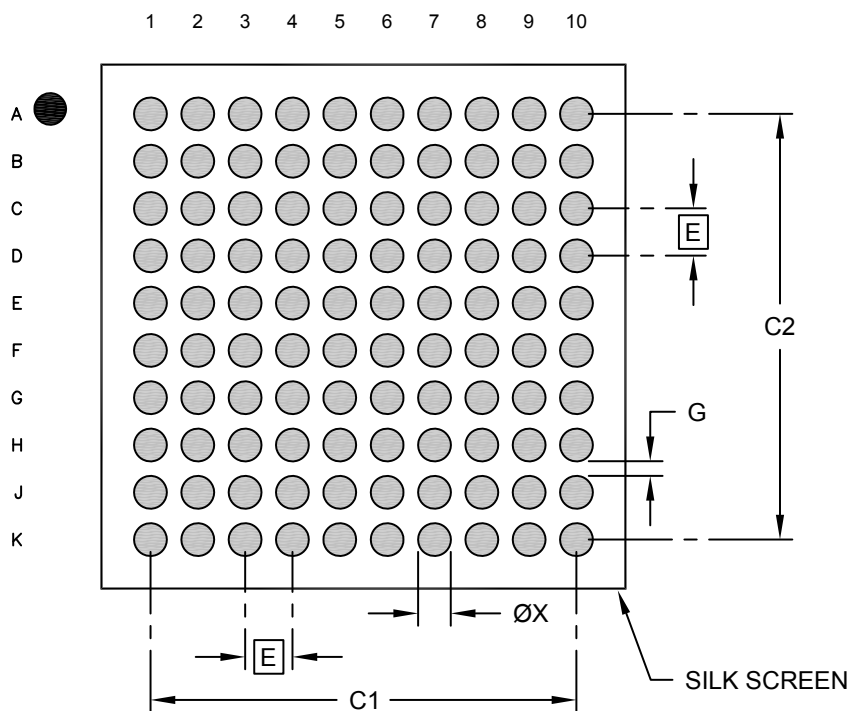

**RECOMMENDED LAND PATTERN**

Dimension Limits	Units	MILLIMETERS		
		MIN	NOM	MAX
Contact Pitch	E	0.65 BSC		
Overall Contact Pad Spacing	C1		5.85	
Overall Contact Pad Spacing	C2		5.85	
Contact Pad Width (X100)	X1			0.45
Contact Pad to Contact Pad	G	0.20		

**Notes:**

1. Dimensioning and tolerancing per ASME Y14.5M

BSC: Basic Dimension. Theoretically exact value shown without tolerances.

**Package Outlines and Dimensions**

**121-Ball Thin Fine Pitch Ball Grid Array (3XX) - 8x8 mm Body [TFBGA]  
System In Package**

**Note:** For the most current package drawings, please see the Microchip Packaging Specification located at <http://www.microchip.com/packaging>

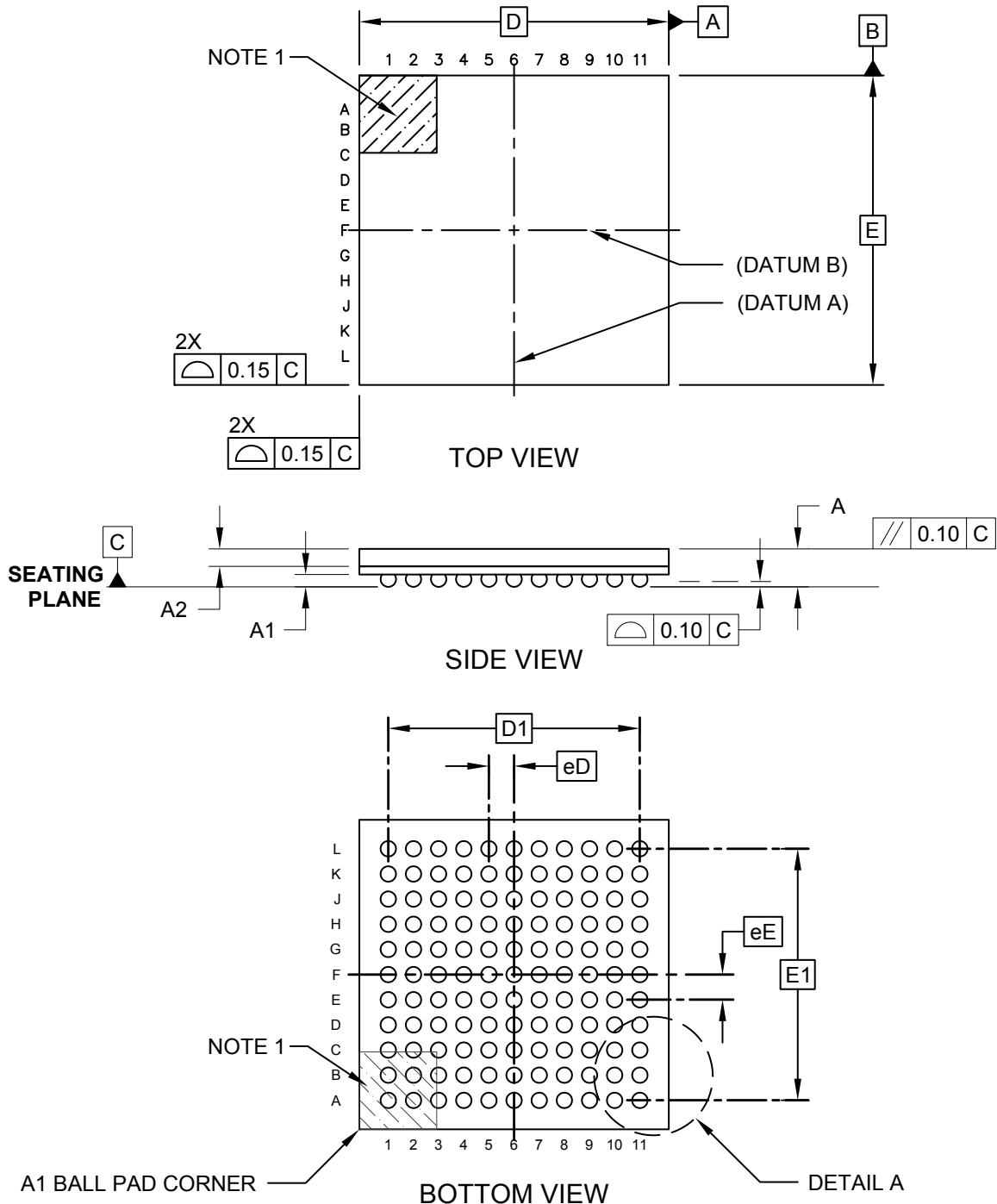

## Package Outlines and Dimensions

### 121-Ball Thin Fine Pitch Ball Grid Array (3XX) - 8x8 mm Body [TFBGA] System In Package

**Note:** For the most current package drawings, please see the Microchip Packaging Specification located at <http://www.microchip.com/packaging>

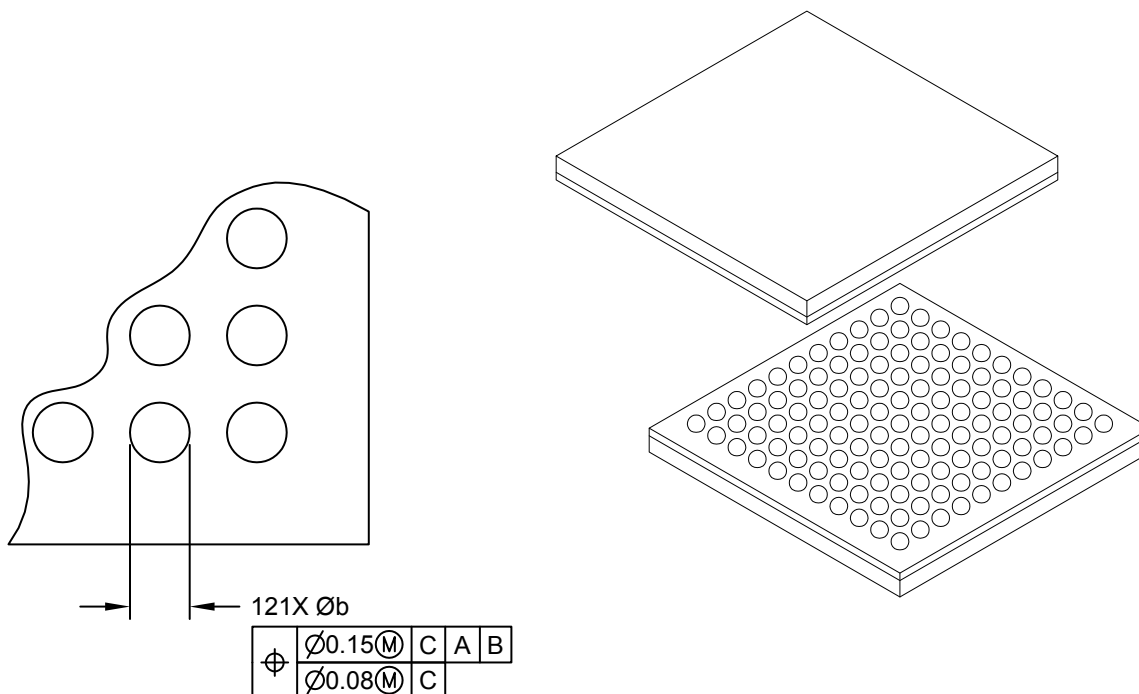

DETAIL A

Dimension Limits	Units	MILLIMETERS		
		MIN	NOM	MAX
Number of Terminals	N	121		
Pitch	eE	0.65 BSC		
Pitch	eD	0.65 BSC		
Overall Height	A	-	-	1.08
Standoff	A1	0.21	0.32	-
Cap Thickness	A2	0.40	0.45	0.50
Overall Width	E	8.00 BSC		
Overall Pitch	E1	6.50 BSC		
Overall Length	D	8.00 BSC		
Overall Pitch	D1	6.50 BSC		
Terminal Diameter	b	.035	0.40	0.45

**Notes:**

- Terminal A1 visual index feature may vary, but must be located within the hatched area.
- Dimensioning and tolerancing per ASME Y14.5M

BSC: Basic Dimension. Theoretically exact value shown without tolerances.

REF: Reference Dimension, usually without tolerance, for information purposes only.



## Footprint Outlines and Dimensions

### 121-Ball Thin Fine Pitch Ball Grid Array (3XX) - 8x8 mm Body [TFBGA] System In Package

**Note:** For the most current package drawings, please see the Microchip Packaging Specification located at <http://www.microchip.com/packaging>

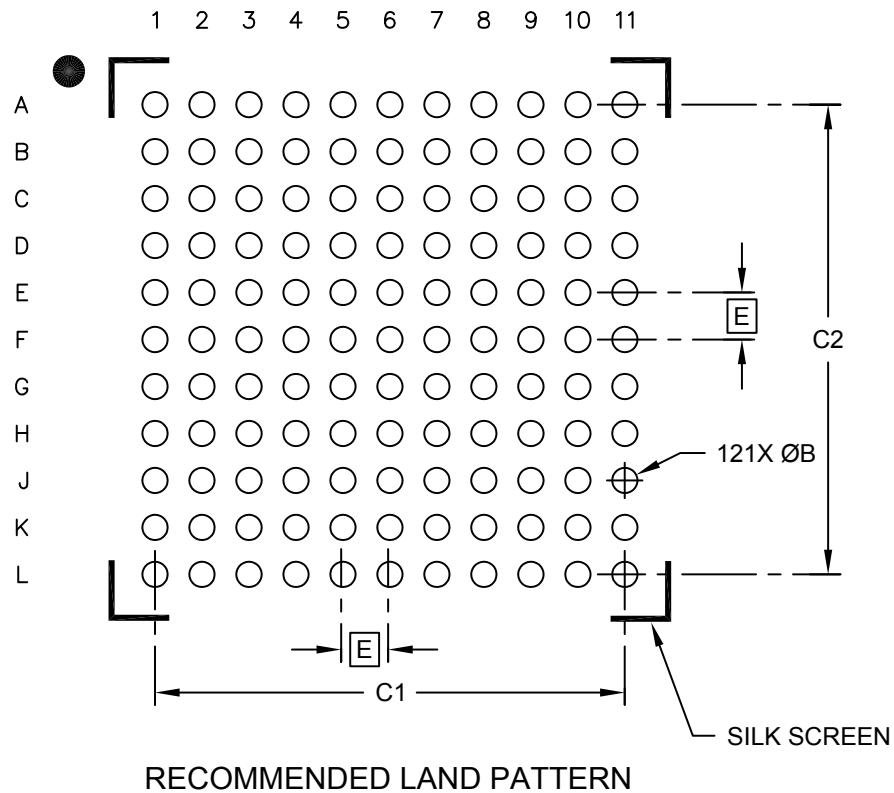

Units		MILLIMETERS		
Dimension Limits		MIN	NOM	MAX
Contact Pitch	E	0.65 BSC		
Contact Pad Spacing	C1		6.50	
Contact Pad Spacing	C2		6.50	
Contact Pad Diameter (X121)	B		0.35	

**Notes:**

1. Dimensioning and tolerancing per ASME Y14.5M

BSC: Basic Dimension. Theoretically exact value shown without tolerances.

Microchip Technology Drawing No. C04-2212B-3XX

**Package Outlines and Dimensions**

**121-Ball Thin Fine Pitch Ball Grid Array (TE) - 8x8 mm Body [TFBGA]  
System In Package**

**Note:** For the most current package drawings, please see the Microchip Packaging Specification located at <http://www.microchip.com/packaging>

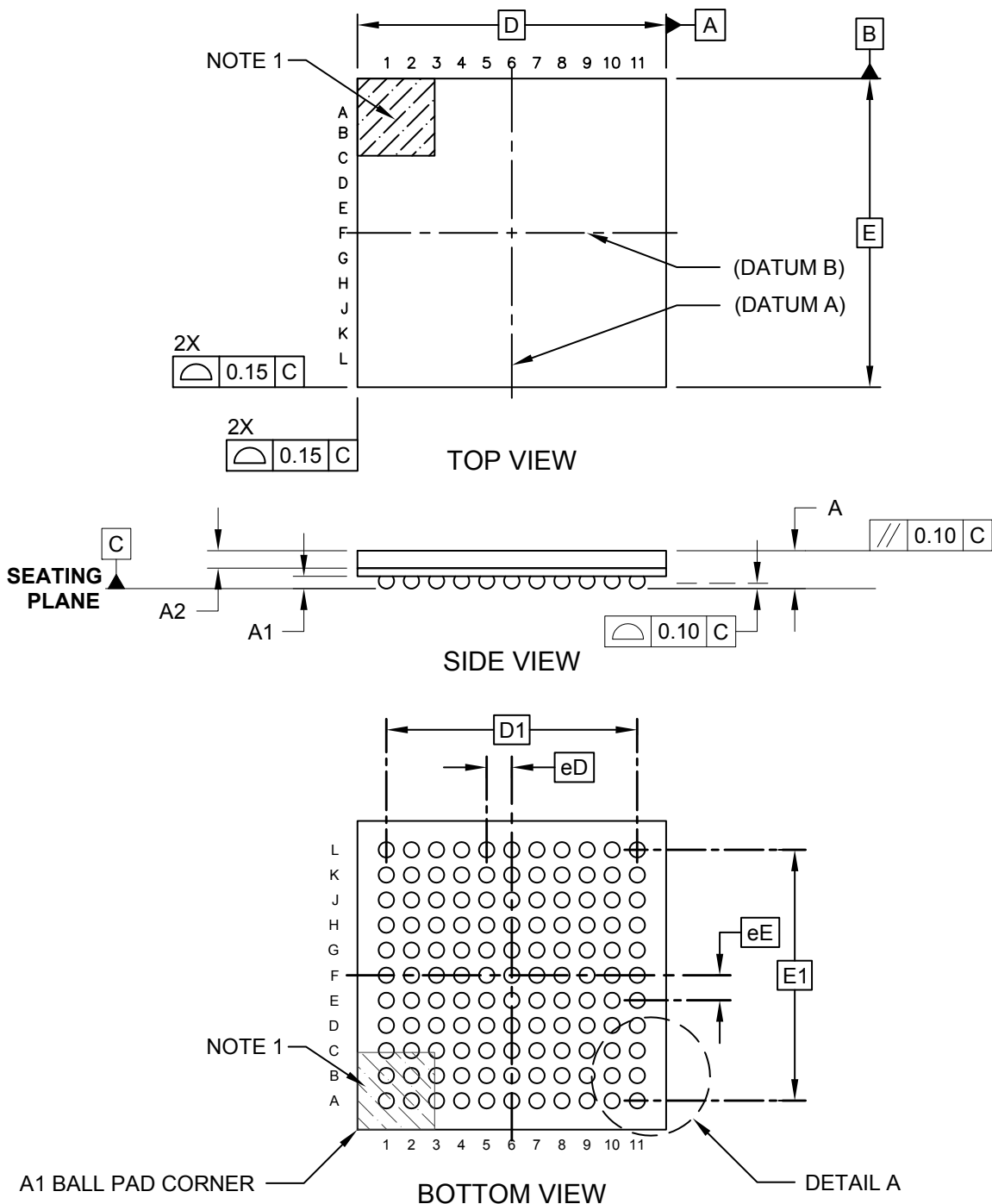

---



---

## Package Outlines and Dimensions

---



---

### 121-Ball Thin Fine Pitch Ball Grid Array (TE) - 8x8 mm Body [TFBGA] System In Package

**Note:** For the most current package drawings, please see the Microchip Packaging Specification located at <http://www.microchip.com/packaging>

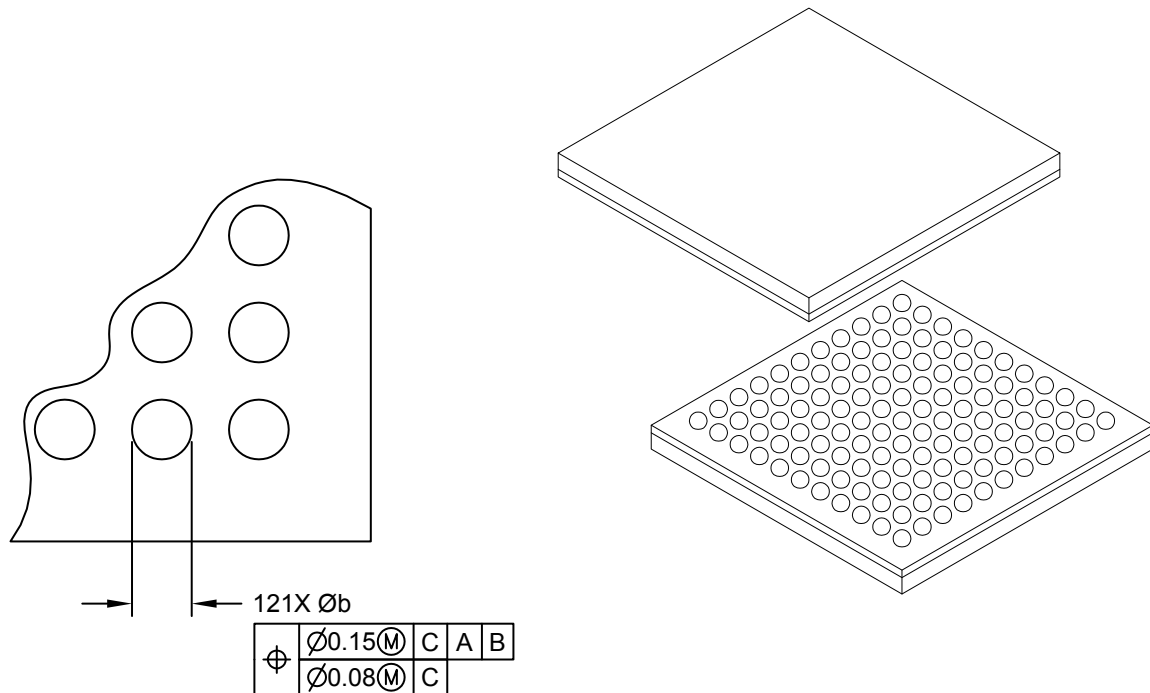

DETAIL A

Dimension Limits	Units	MILLIMETERS		
		MIN	NOM	MAX
Number of Terminals	N	121		
Pitch	eE	0.65 BSC		
Pitch	eD	0.65 BSC		
Overall Height	A	-	-	1.08
Standoff	A1	0.21	0.32	-
Cap Thickness	A2	0.40	0.45	0.50
Overall Width	E	8.00 BSC		
Overall Pitch	E1	6.50 BSC		
Overall Length	D	8.00 BSC		
Overall Pitch	D1	6.50 BSC		
Terminal Diameter	b	.035	0.40	0.45

**Notes:**

1. Terminal A1 visual index feature may vary, but must be located within the hatched area.
2. Dimensioning and tolerancing per ASME Y14.5M
  - BSC: Basic Dimension. Theoretically exact value shown without tolerances.
  - REF: Reference Dimension, usually without tolerance, for information purposes only.

**Footprint Outlines and Dimensions**

**121-Ball Thin Fine Pitch Ball Grid Array (TE) - 8x8 mm Body [TFBGA]  
System In Package**

**Note:** For the most current package drawings, please see the Microchip Packaging Specification located at <http://www.microchip.com/packaging>

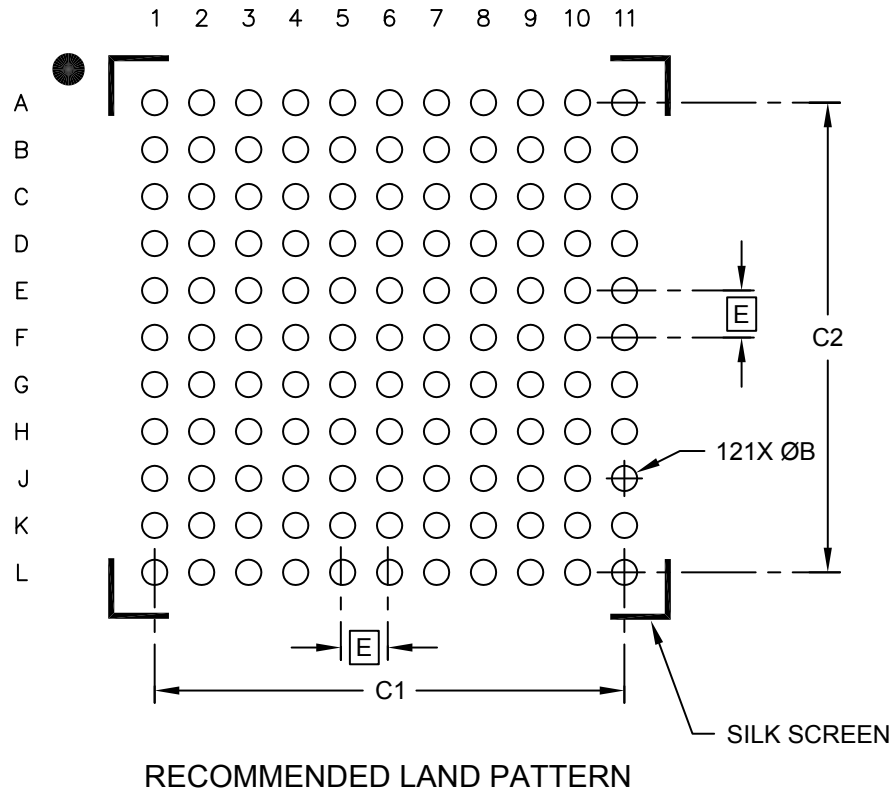

Units		MILLIMETERS		
Dimension Limits		MIN	NOM	MAX
Contact Pitch	E	0.65 BSC		
Contact Pad Spacing	C1		6.50	
Contact Pad Spacing	C2		6.50	
Contact Pad Diameter (X121)	B		0.35	

**Notes:**

1. Dimensioning and tolerancing per ASME Y14.5M

BSC: Basic Dimension. Theoretically exact value shown without tolerances.

Microchip Technology Drawing No. C04-2212B-TE

**Package Outlines and Dimensions**

**121-Ball Plastic Thin Profile Fine Pitch Ball Grid Array (BG) -  
10x10x1.10 mm Body [TFBGA]**

**Note:** For the most current package drawings, please see the Microchip Packaging Specification located at <http://www.microchip.com/packaging>

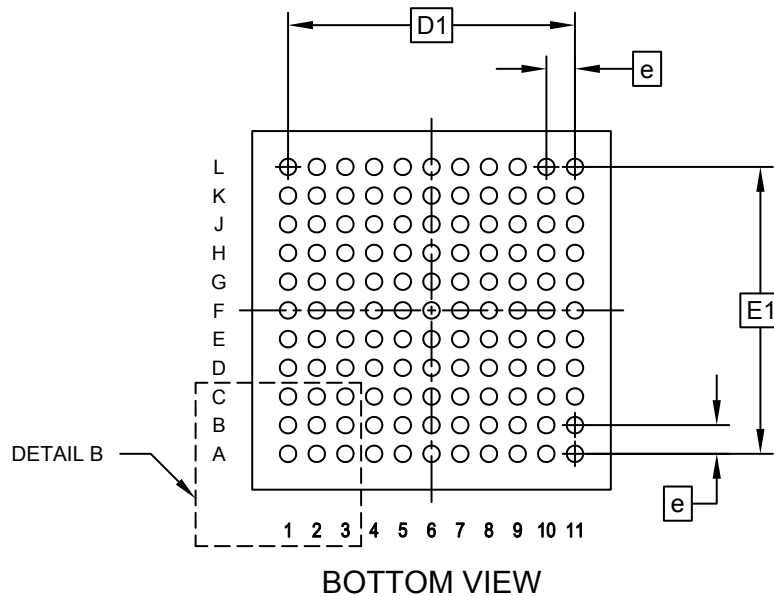
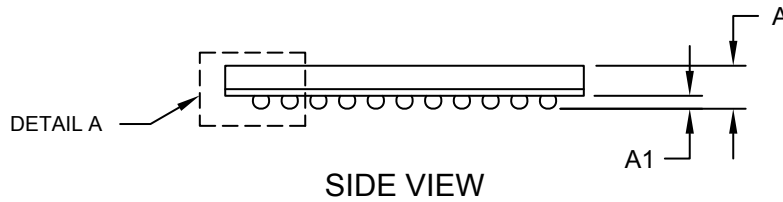
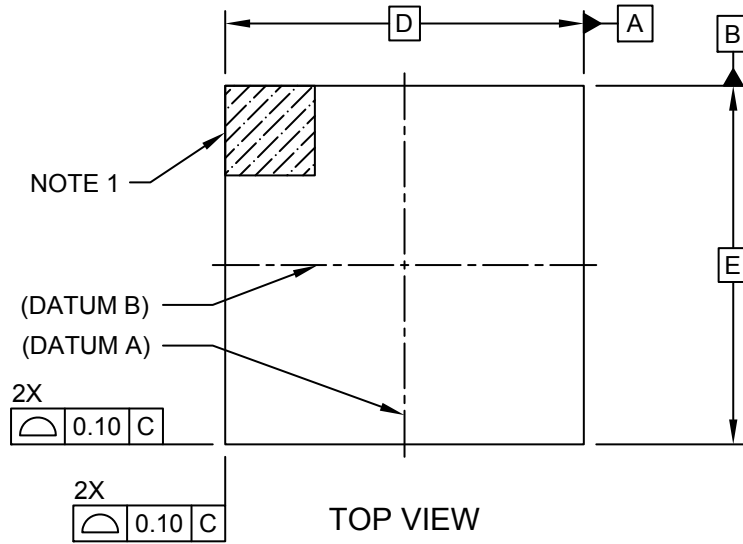

## Package Outlines and Dimensions

### 121-Ball Plastic Thin Profile Fine Pitch Ball Grid Array (BG) - 10x10x1.10 mm Body [TFBGA]

**Note:** For the most current package drawings, please see the Microchip Packaging Specification located at <http://www.microchip.com/packaging>

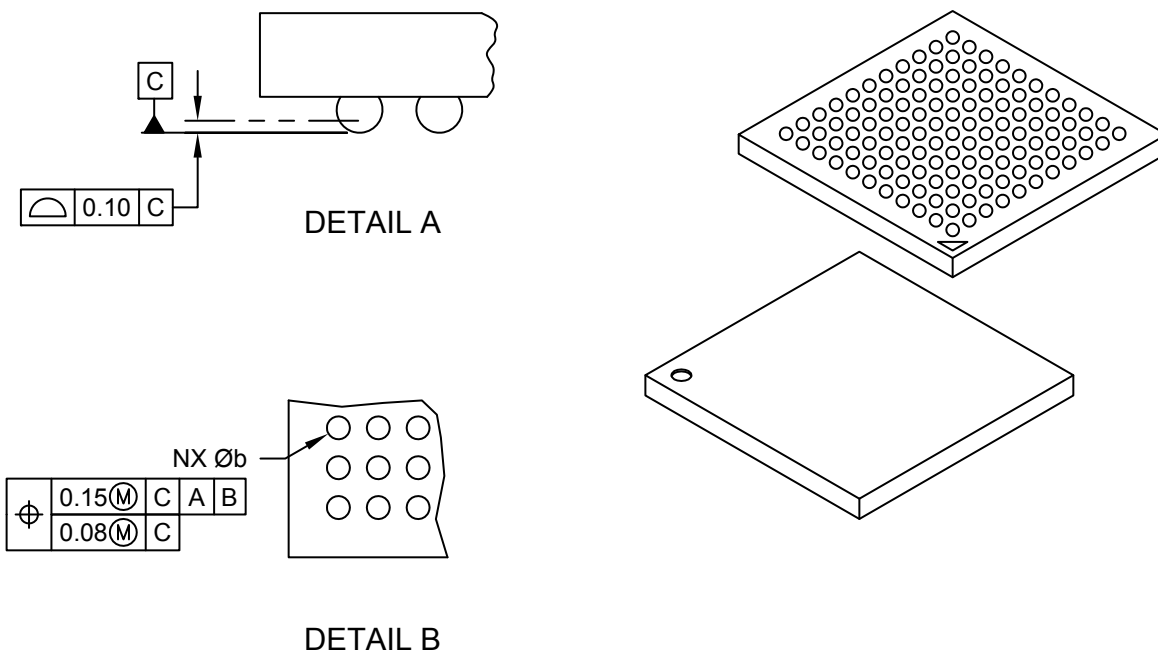

Dimension Limits	Units	MILLIMETERS		
		MIN	NOM	MAX
Number of Contacts	N	121		
Contact Pitch	e	0.80 BSC		
Overall Height	A	1.00	1.10	1.20
Ball Height	A1	0.25	0.30	0.35
Overall Width	E	10.00 BSC		
Array Width	E1	8.00 BSC		
Overall Length	D	10.00 BSC		
Array Length	D1	8.00 BSC		
Contact Diameter	b	0.35	0.40	0.45

**Notes:**

- Ball A1 visual index feature may vary, but must be located within the hatched area.
- Dimensioning and tolerancing per ASME Y14.5M.  
BSC: Basic Dimension. Theoretically exact value shown without tolerances.  
REF: Reference Dimension, usually without tolerance, for information purposes only.
- The outer rows and columns of balls are located with respect to datums A and B.
- Ball interface to package body: 0.37mm nominal diameter.

---



---

**Footprint Outlines and Dimensions**

---



---

**121-Lead Plastic Thin Profile Ball Grid Array (BG) - 10x10x1.10 mm Body  
[TFBGA--Formerly XBGA]**

**Note:** For the most current package drawings, please see the Microchip Packaging Specification located at <http://www.microchip.com/packaging>

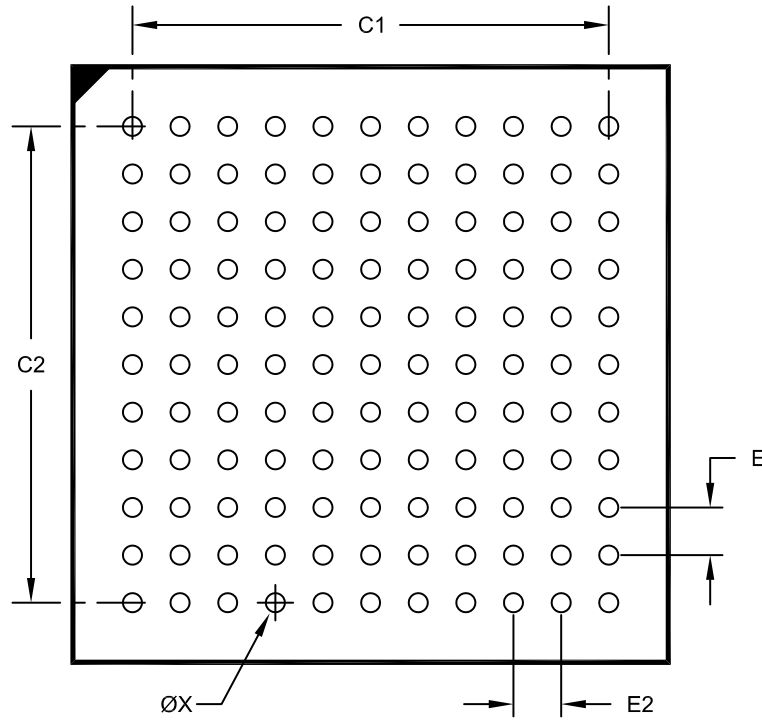

**RECOMMENDED LAND PATTERN**

		Units	MILLIMETERS		
		Dimension Limits	MIN	NOM	MAX
Contact Pitch	E1		0.80 BSC		
Contact Pitch	E2		0.80 BSC		
Contact Pad Spacing	C1			8.00	
Contact Pad Spacing	C2			8.00	
Contact Pad Diameter (X121)	X				0.32

**Notes:**

1. Dimensioning and tolerancing per ASME Y14.5M

BSC: Basic Dimension. Theoretically exact value shown without tolerances.

Microchip Technology Drawing No. C04-2148 Rev D

**Package Outlines and Dimensions**

**129-Ball Thin Fine Pitch Ball Grid Array (2H) - 7x7 mm Body [TFBGA]**

**Note:** For the most current package drawings, please see the Microchip Packaging Specification located at <http://www.microchip.com/packaging>

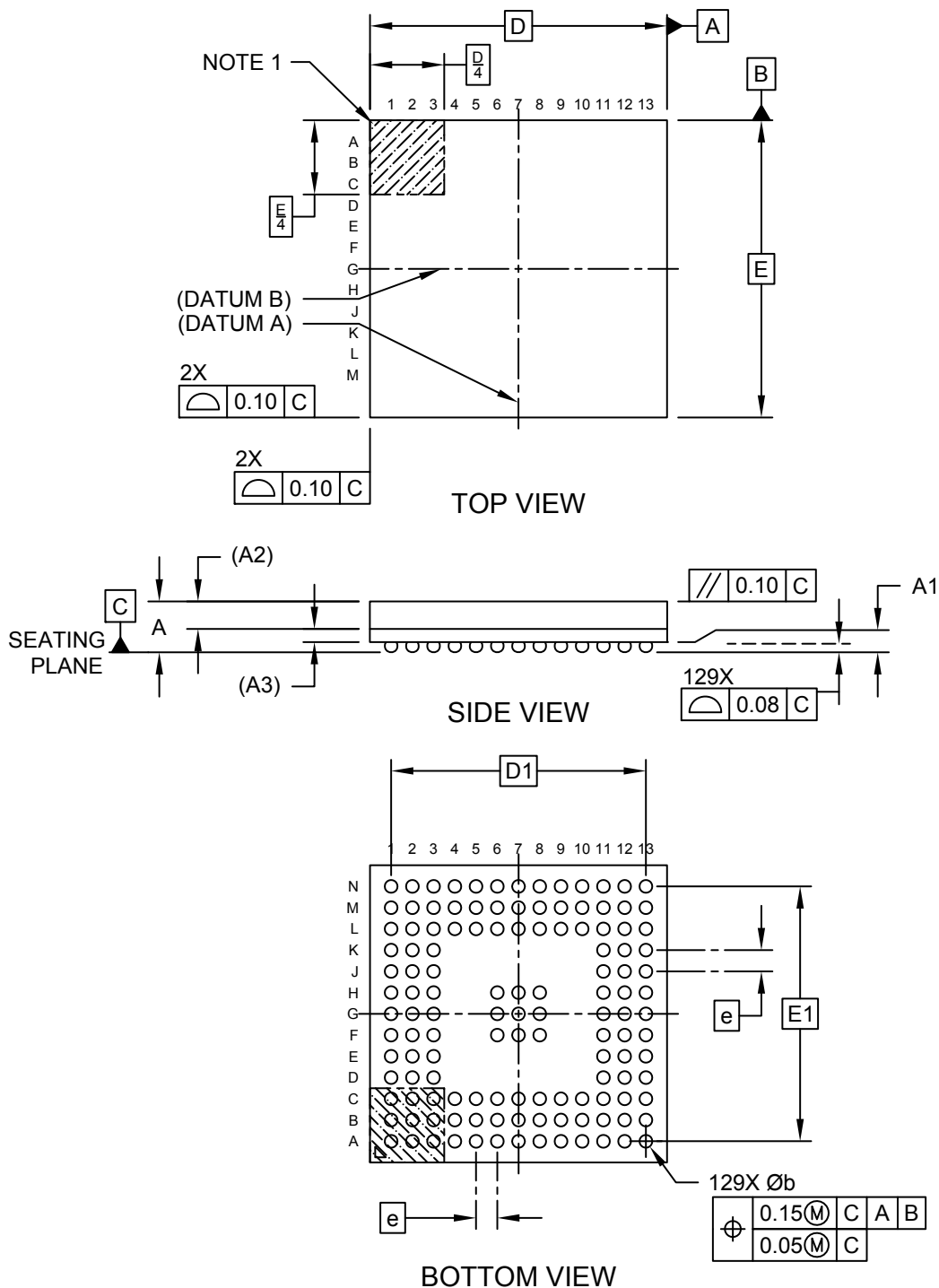



---



---

## Package Outlines and Dimensions

---



---

### 129-Ball Thin Fine Pitch Ball Grid Array (2H) - 7x7 mm Body [TFBGA]

**Note:** For the most current package drawings, please see the Microchip Packaging Specification located at <http://www.microchip.com/packaging>

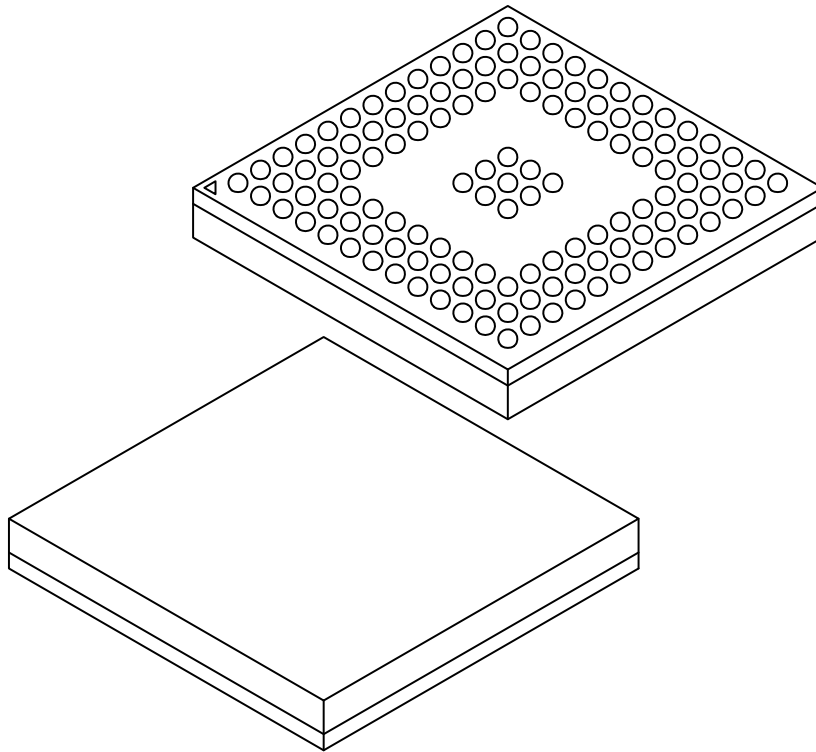

Dimension Limits	Units	MILLIMETERS		
		MIN	NOM	MAX
Number of Terminals	N	129		
Pitch	e	0.50 BSC		
Overall Height	A	-	-	1.20
Standoff	A1	0.20	0.24	0.28
Mold Thickness	A2	0.65 REF		
Substrate Thickness	A3	0.21 REF		
Overall Length	D	7.00 BSC		
Overall Terminal Spacing	D1	6.00 BSC		
Overall Width	E	7.00 BSC		
Overall Terminal Spacing	E1	6.00 BSC		
Terminal Diameter	b	0.25	0.30	0.35

**Notes:**

1. Pin 1 visual index feature may vary, but must be located within the hatched area.
2. Dimensioning and tolerancing per ASME Y14.5M
  - BSC: Basic Dimension. Theoretically exact value shown without tolerances.
  - REF: Reference Dimension, usually without tolerance, for information purposes only.

**Footprint Outlines and Dimensions**

**129-Ball Thin Fine Pitch Ball Grid Array (2H) - 7x7 mm Body [TFBGA]**

**Note:** For the most current package drawings, please see the Microchip Packaging Specification located at <http://www.microchip.com/packaging>

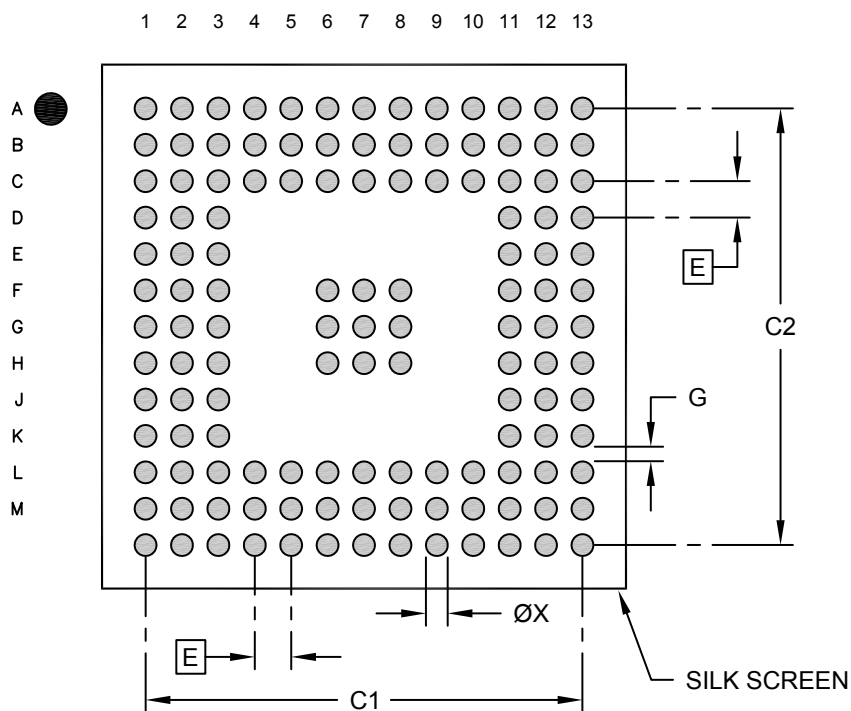

**RECOMMENDED LAND PATTERN**

Dimension Limits	Units	MILLIMETERS		
		MIN	NOM	MAX
Contact Pitch	E	0.50 BSC		
Overall Contact Pad Spacing	C1		6.00	
Overall Contact Pad Spacing	C2		6.00	
Contact Pad Width (X129)	X1			0.30
Contact Pad to Contact Pad	G	0.20		

**Notes:**

1. Dimensioning and tolerancing per ASME Y14.5M

BSC: Basic Dimension. Theoretically exact value shown without tolerances.

**Package Outlines and Dimensions**

**129-Ball Thin Fine Pitch Ball Grid Array (GW) - 7x7 mm Body [TFBGA]**

**Note:** For the most current package drawings, please see the Microchip Packaging Specification located at <http://www.microchip.com/packaging>

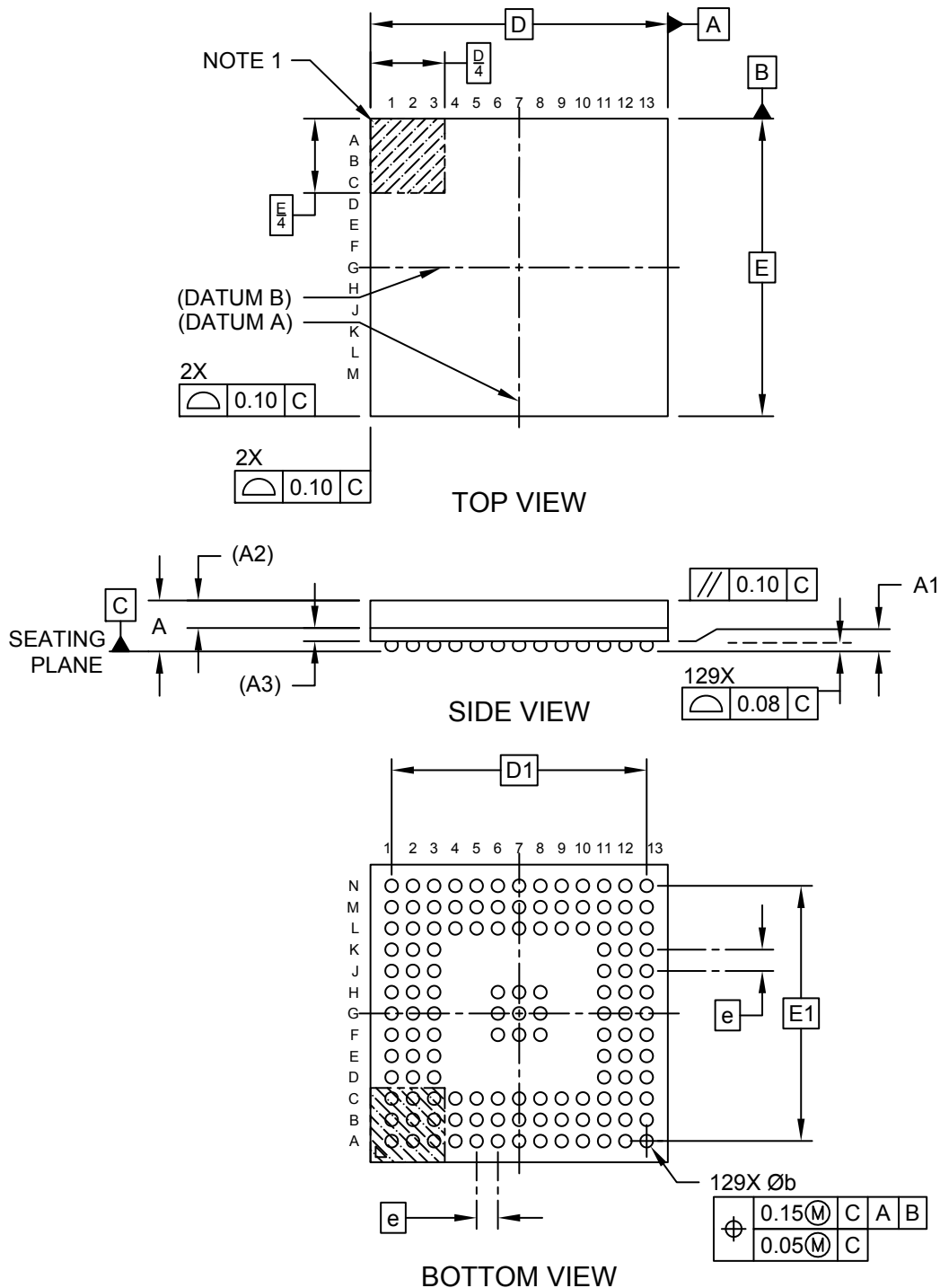

**Package Outlines and Dimensions**

**129-Ball Thin Fine Pitch Ball Grid Array (GW) - 7x7 mm Body [TFBGA]**

**Note:** For the most current package drawings, please see the Microchip Packaging Specification located at <http://www.microchip.com/packaging>

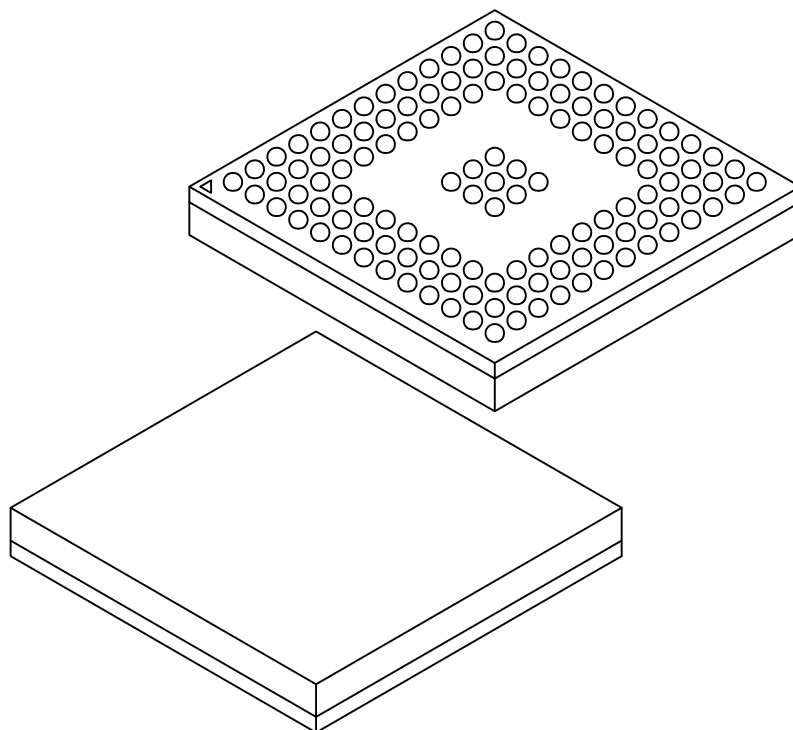

Dimension Limits	Units	MILLIMETERS		
		MIN	NOM	MAX
Number of Terminals	N	129		
Pitch	e	0.50 BSC		
Overall Height	A	-	-	1.20
Standoff	A1	0.20	0.24	0.28
Mold Thickness	A2	0.65 REF		
Substrate Thickness	A3	0.21 REF		
Overall Length	D	7.00 BSC		
Overall Terminal Spacing	D1	6.00 BSC		
Overall Width	E	7.00 BSC		
Overall Terminal Spacing	E1	6.00 BSC		
Terminal Diameter	b	0.25	0.30	0.35

**Notes:**

1. Pin 1 visual index feature may vary, but must be located within the hatched area.
2. Dimensioning and tolerancing per ASME Y14.5M
  - BSC: Basic Dimension. Theoretically exact value shown without tolerances.
  - REF: Reference Dimension, usually without tolerance, for information purposes only.

---



---

## Footprint Outlines and Dimensions

---



---

### 129-Ball Thin Fine Pitch Ball Grid Array (GW) - 7x7 mm Body [TFBGA]

**Note:** For the most current package drawings, please see the Microchip Packaging Specification located at <http://www.microchip.com/packaging>

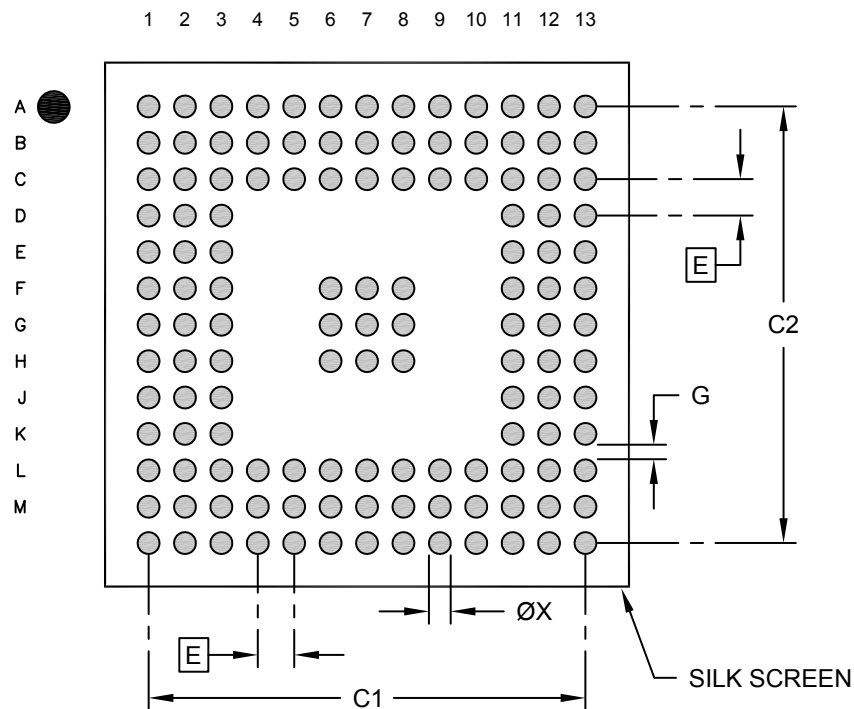

**RECOMMENDED LAND PATTERN**

Dimension Limits	Units	MILLIMETERS		
		MIN	NOM	MAX
Contact Pitch	E	0.50 BSC		
Overall Contact Pad Spacing	C1		6.00	
Overall Contact Pad Spacing	C2		6.00	
Contact Pad Width (X129)	X1			0.30
Contact Pad to Contact Pad	G	0.20		

**Notes:**

1. Dimensioning and tolerancing per ASME Y14.5M

BSC: Basic Dimension. Theoretically exact value shown without tolerances.

**Package Outlines and Dimensions**

**132-Ball Thin Fine Pitch Ball Grid Array (AHA) - 12x12x1.2mm Body [TFBGA]**

**Note:** For the most current package drawings, please see the Microchip Packaging Specification located at <http://www.microchip.com/packaging>

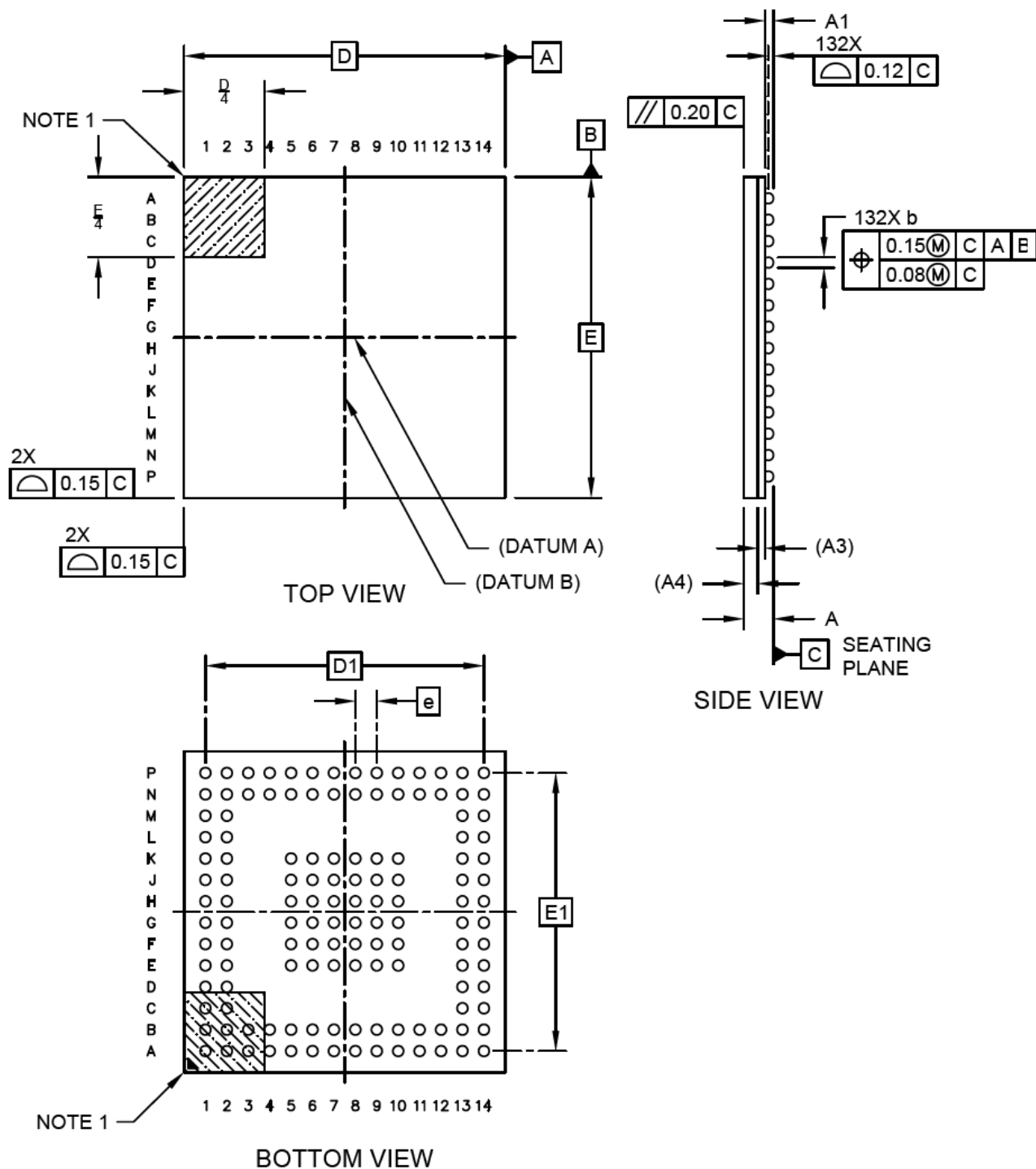

---



---

## Package Outlines and Dimensions

---



---

### 132-Ball Thin Fine Pitch Ball Grid Array (AHA) - 12x12x1.2mm Body [TFBGA]

**Note:** For the most current package drawings, please see the Microchip Packaging Specification located at <http://www.microchip.com/packaging>

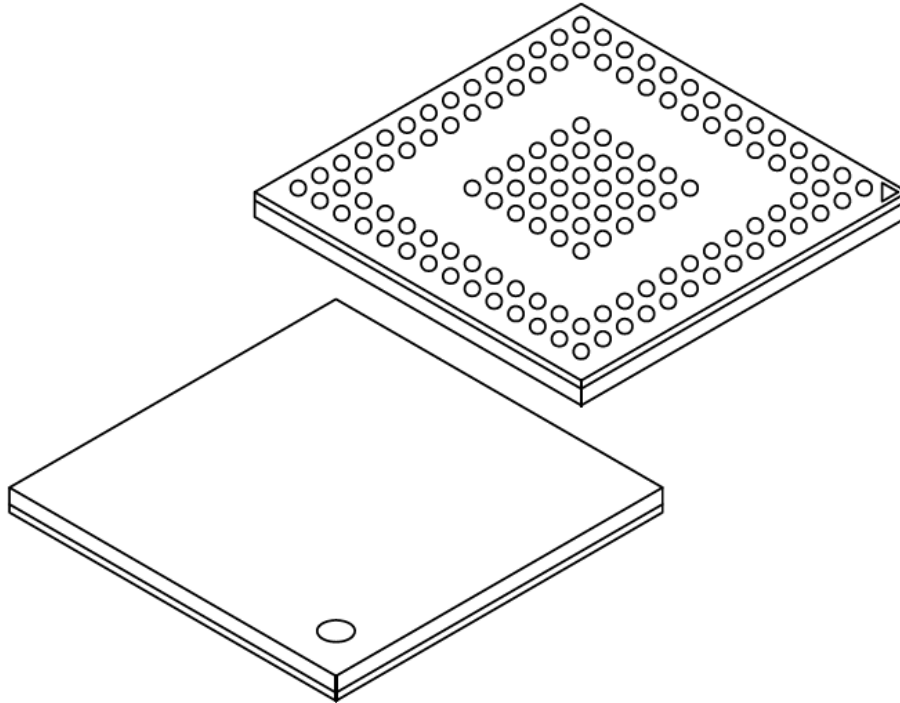

		MILLIMETERS		
		MIN	NOM	MAX
Number of Terminals	N	132		
Pitch	e	0.80 BSC		
Overall Height	A	-	-	1.20
Standoff	A1	0.27	0.32	0.37
Substrate Thickness	A2	0.26 REF		
Mold Cap Thickness	A4	0.53 REF		
Overall Length	D	12.00 BSC		
Overall Terminal Centers	D1	10.40 BSC		
Overall Width	E	12.00 BSC		
Overall Terminal Centers	E1	10.40 BSC		
Terminal Diameter	b	0.35	0.40	0.45

**Notes:**

1. Pin 1 visual index feature may vary, but must be located within the hatched area.
2. Package is saw singulated
3. Dimensioning and tolerancing per ASME Y14.5M
  - BSC: Basic Dimension. Theoretically exact value shown without tolerances.
  - REF: Reference Dimension, usually without tolerance, for information purposes only.

**Footprint Outlines and Dimensions**

**132-Ball Thin Fine Pitch Ball Grid Array (AHA) - 12x12x1.2mm Body [TFBGA]**

**Note:** For the most current package drawings, please see the Microchip Packaging Specification located at <http://www.microchip.com/packaging>

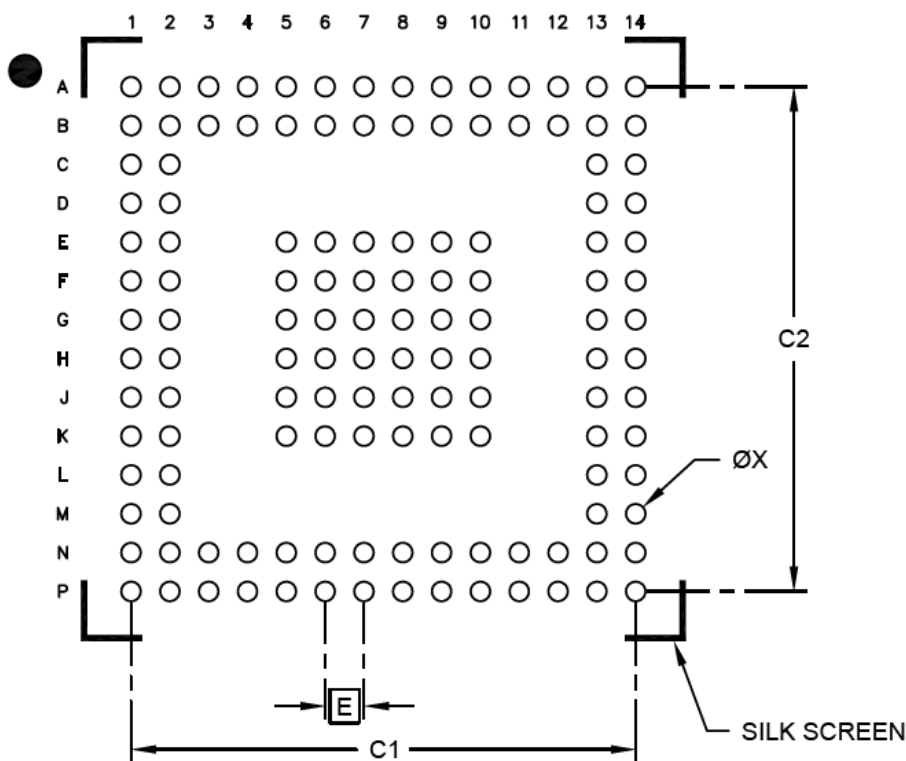

**RECOMMENDED LAND PATTERN**

Dimension Limits	Units	MILLIMETERS		
		MIN	NOM	MAX
Contact Pitch	E	0.80 BSC		
Contact Pad Diameter	ØX		0.40	
Contact Pad Spacing	C1		10.40	
Contact Pad Spacing	C2		10.40	

**Notes:**

1. Dimensioning and tolerancing per ASME Y14.5M

BSC: Basic Dimension. Theoretically exact value shown without tolerances.



**Package Outlines and Dimensions**

**144-Ball Thin Fine Pitch Ball Grid Array [JWX] - 7x7 mm Body (TFBGA)**

**Note:** For the most current package drawings, please see the Microchip Packaging Specification located at <http://www.microchip.com/packaging>

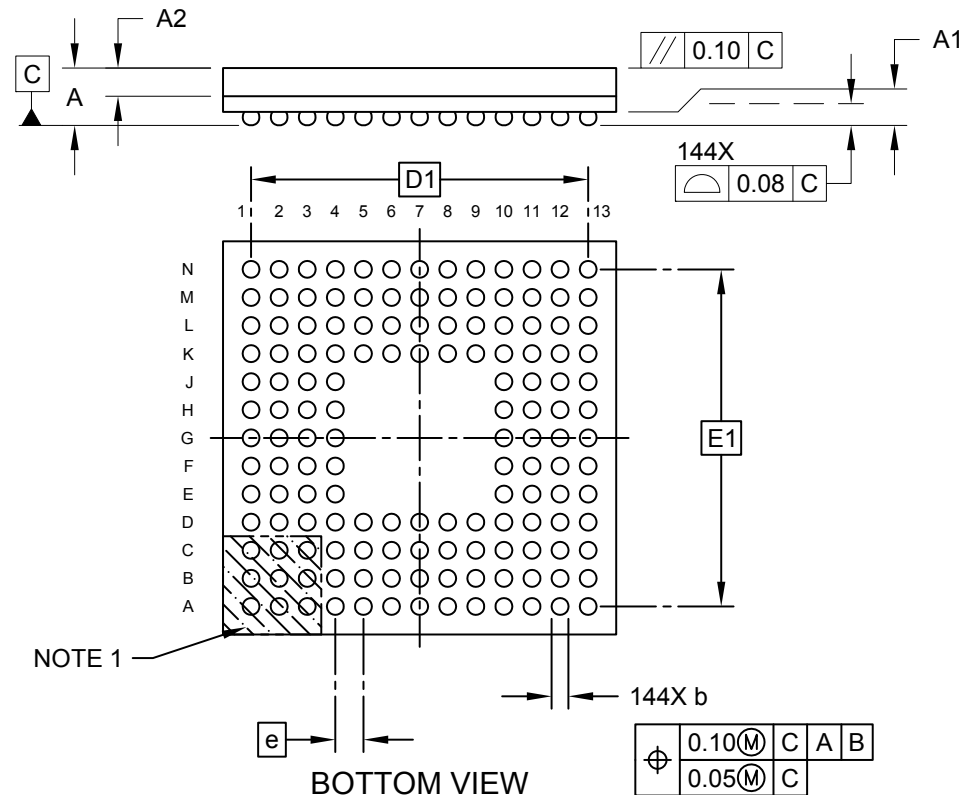
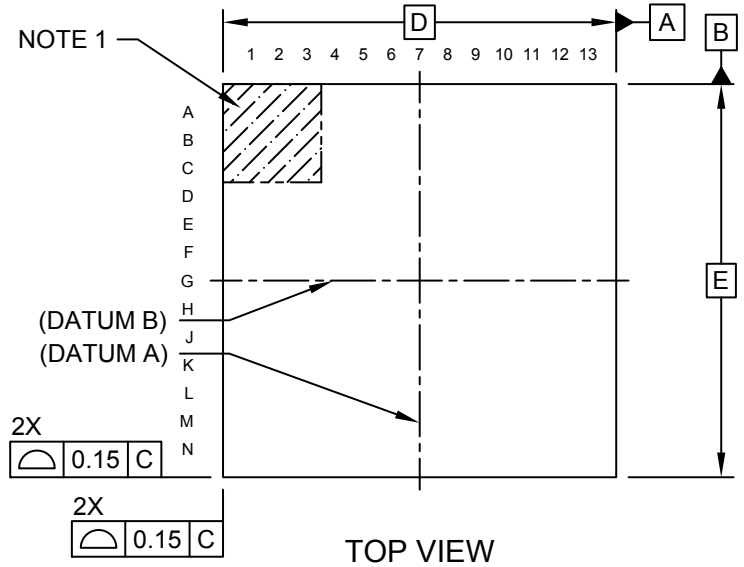

**Package Outlines and Dimensions**

**144-Ball Thin Fine Pitch Ball Grid Array [JWX] - 7x7 mm Body (TFBGA)**

**Note:** For the most current package drawings, please see the Microchip Packaging Specification located at <http://www.microchip.com/packaging>

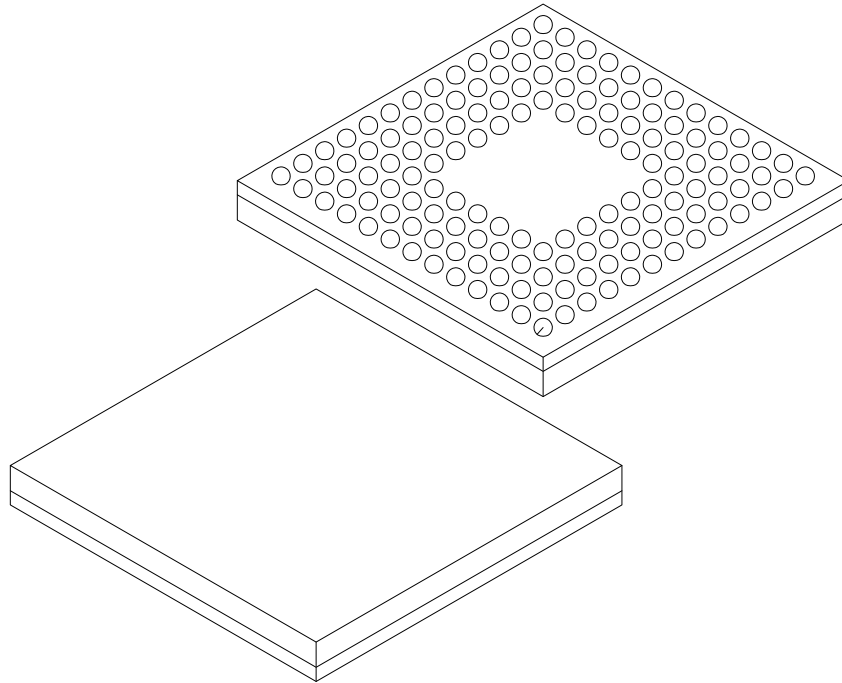

		Units	MILLIMETERS		
Dimension Limits			MIN	NOM	MAX
Number of Terminals	N		144		
Pitch	e		0.50 BSC		
Overall Height	A	-	-	-	1.02
Standoff	A1	0.15	0.24	-	-
Molded Cap Height	A2	0.45	0.50	0.55	-
Overall Length	D		7.00 BSC		
Overall Pitch	D1		6.00 BSC		
Overall Width	E		7.00 BSC		
Overall Pitch	D1		6.00 BSC		
Ball Diameter	b	0.25	0.30	0.35	-

Notes:

1. Terminal A1 visual index feature may vary, but must be located within the hatched area.
2. Package is saw singulated
3. Dimensioning and tolerancing per ASME Y14.5M

BSC: Basic Dimension. Theoretically exact value shown without tolerances.

REF: Reference Dimension, usually without tolerance, for information purposes only.

**Footprint Outlines and Dimensions**

**144-Ball Thin Fine Pitch Ball Grid Array [JWX] - 7x7 mm Body (TFBGA)**

**Note:** For the most current package drawings, please see the Microchip Packaging Specification located at <http://www.microchip.com/packaging>

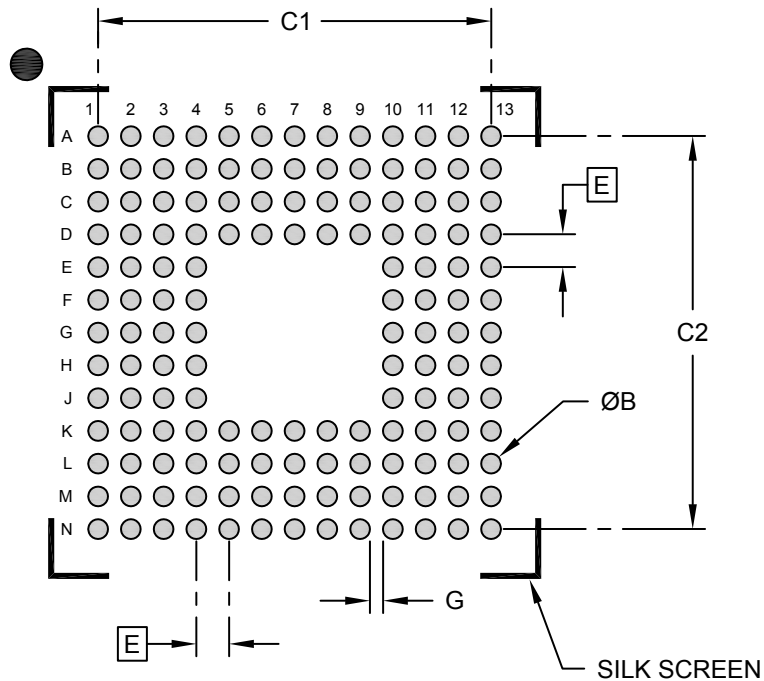

**RECOMMENDED LAND PATTERN**

Dimension Limits	Units	MILLIMETERS		
		MIN	NOM	MAX
Contact Pitch	E	0.50 BSC		
Overall Contact Pitch	C1		6.00	
Overall Contact Pitch	C2		6.00	
Contact Diameter (X 144)	X1			0.30
Spacing Between Contacts	G	0.30		

**Notes:**

1. Dimensioning and tolerancing per ASME Y14.5M  
BSC: Basic Dimension. Theoretically exact value shown without tolerances.

**Package Outlines and Dimensions**

**168-Ball Thin Fine-Pitch Ball Grid Array (AFA) - 13x13x1.2 mm Body [TFBGA]**

**Note:** For the most current package drawings, please see the Microchip Packaging Specification located at <http://www.microchip.com/packaging>

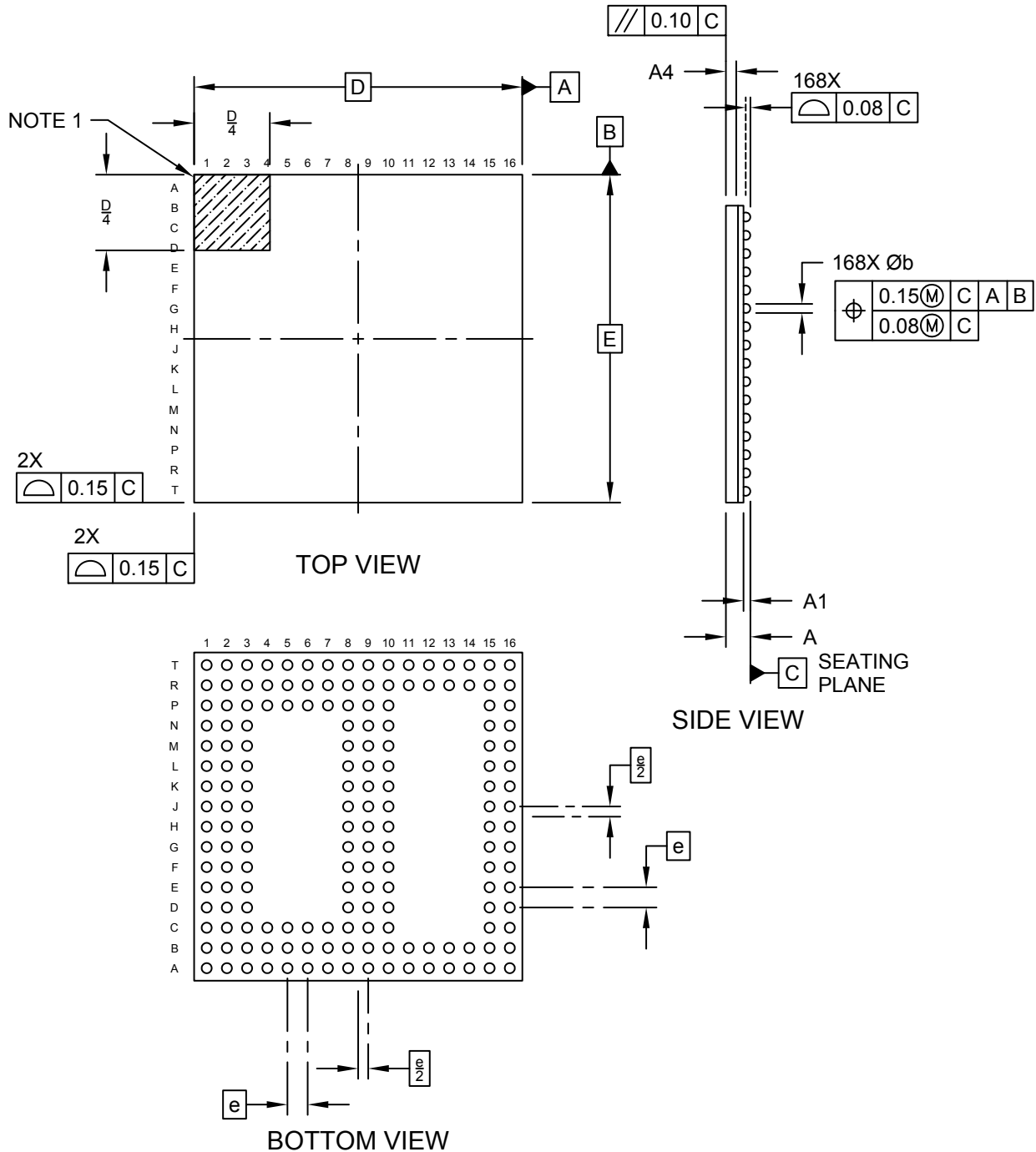

---



---

## Package Outlines and Dimensions

---



---

### 168-Ball Thin Fine-Pitch Ball Grid Array (AFA) - 13x13x1.2 mm Body [TFBGA]

**Note:** For the most current package drawings, please see the Microchip Packaging Specification located at <http://www.microchip.com/packaging>

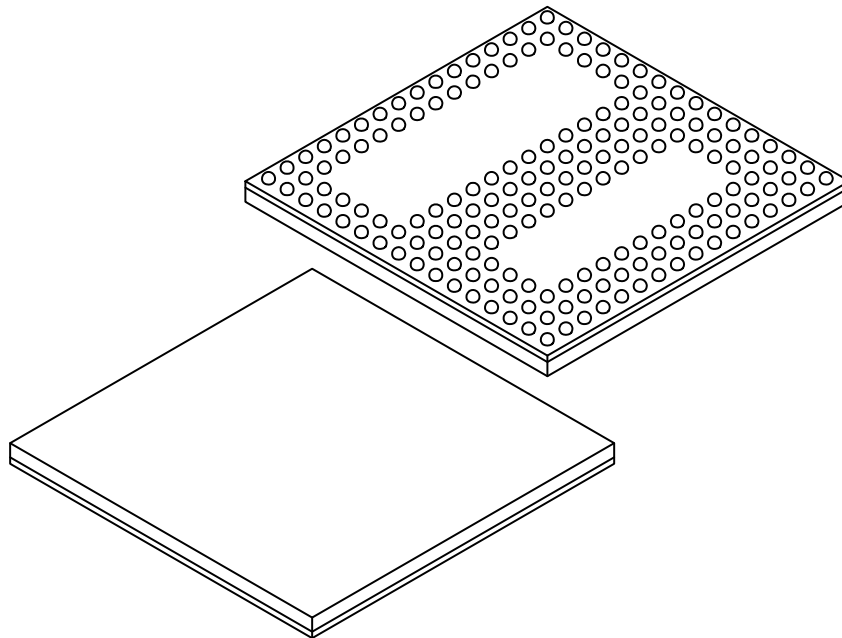

		MILLIMETERS		
		MIN	NOM	MAX
Number of Terminals	N	168		
Pitch	e	0.80 BSC		
Overall Height	A	-	-	1.20
Standoff	A1	0.23	0.33	-
Mold Cap Height	A4	0.53 REF		
Overall Length	D	13.00 BSC		
Overall Width	E	13.00 BSC		
Ball Diameter	b	0.35	0.40	0.45

**Notes:**

1. Pin 1 visual index feature may vary, but must be located within the hatched area.
2. Dimensioning and tolerancing per ASME Y14.5M  
 BSC: Basic Dimension. Theoretically exact value shown without tolerances.  
 REF: Reference Dimension, usually without tolerance, for information purposes only.

**Footprint Outlines and Dimensions**

**168-Ball Thin Fine-Pitch Ball Grid Array (AFA) - 13x13x1.2 mm Body [TFBGA]**

**Note:** For the most current package drawings, please see the Microchip Packaging Specification located at <http://www.microchip.com/packaging>

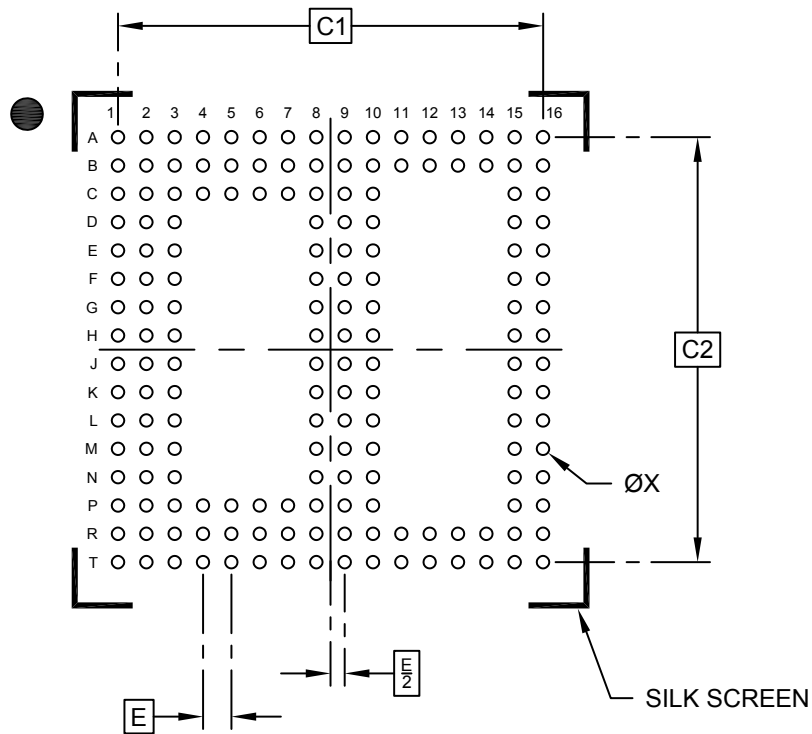

**RECOMMENDED LAND PATTERN**

Dimension Limits	Units	MILLIMETERS		
		MIN	NOM	MAX
Contact Pitch	E	0.80 BSC		
Overall Contact Pad Spacing	C1	12.00 BSC		
Overall Contact Pad Spacing	C2	12.00 BSC		
Pad Diameter (X168)	ØX			0.35

**Notes:**

1. Dimensioning and tolerancing per ASME Y14.5M  
BSC: Basic Dimension. Theoretically exact value shown without tolerances.

**Package Outlines and Dimensions**

**169-Ball Thin Fine Pitch Ball Grid Array (7G) - 10x10x1.10 mm Body [TFBGA]  
(Complies with JEDEC Terminal Assignment recommendations)**

**Note:** For the most current package drawings, please see the Microchip Packaging Specification located at <http://www.microchip.com/packaging>

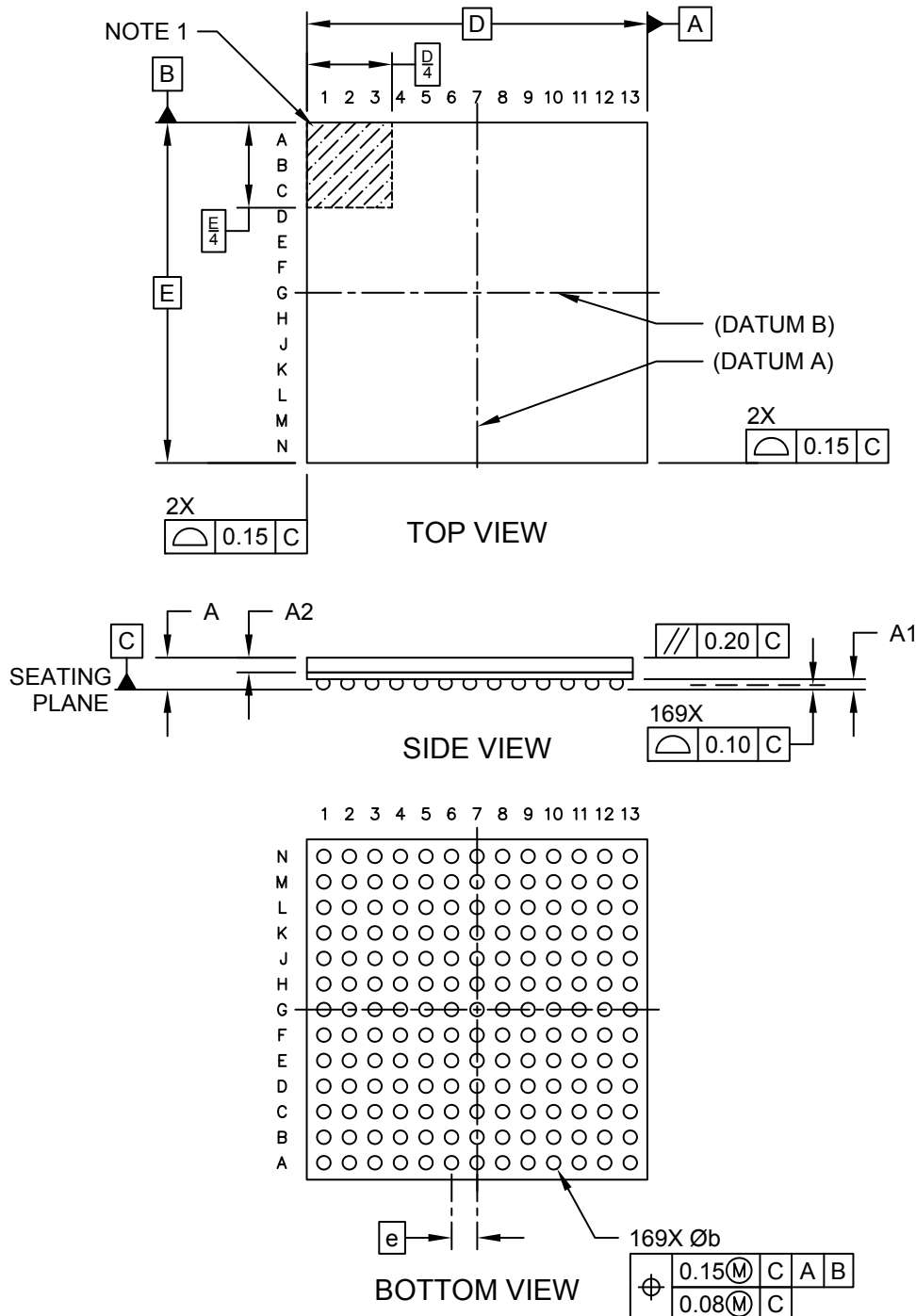

**Package Outlines and Dimensions**

**169-Ball Thin Fine Pitch Ball Grid Array (7G) - 10x10x1.10 mm Body [TFBGA]  
(Complies with JEDEC Terminal Assignment recommendations)**

**Note:** For the most current package drawings, please see the Microchip Packaging Specification located at <http://www.microchip.com/packaging>

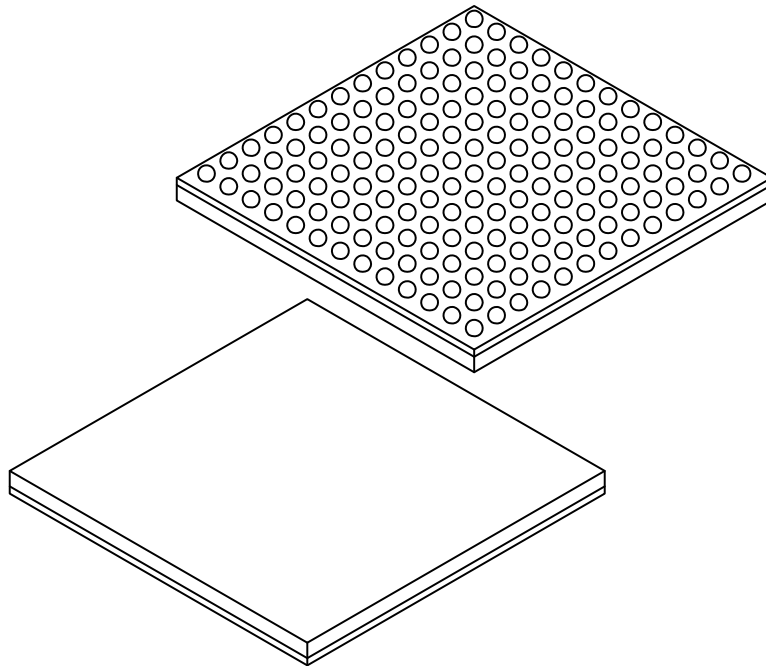

		MILLIMETERS		
Units		MIN	NOM	MAX
Dimension Limits				
Number of Terminals	N	169		
Pitch	e	0.75 BSC		
Overall Height	A	-	-	1.10
Standoff	A1	0.21	0.32	-
Mold Cap Thickness	A2	0.50	0.45	0.50
Overall Length	D	10.00		
Overall Width	E	10.00		
Ball Diameter	b	0.35	0.40	0.45

**Notes:**

1. Terminal A1 visual index feature may vary, but must be located within the hatched area.
2. Package is saw singulated
3. Dimensioning and tolerancing per ASME Y14.5M

BSC: Basic Dimension. Theoretically exact value shown without tolerances.

REF: Reference Dimension, usually without tolerance, for information purposes only.



## Footprint Outlines and Dimensions

### 169-Ball Thin Fine Pitch Ball Grid Array (7G) - 10x10x1.10 mm Body [TFBGA] (Complies with JEDEC Terminal Assignment recommendations)

**Note:** For the most current package drawings, please see the Microchip Packaging Specification located at <http://www.microchip.com/packaging>

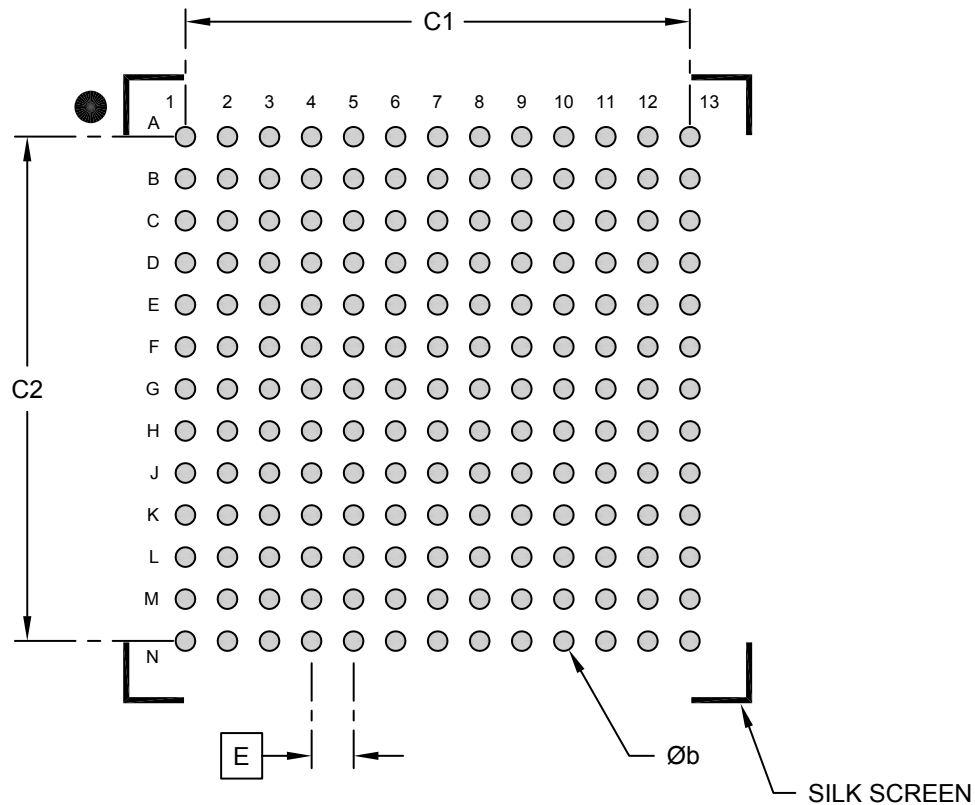

### RECOMMENDED LAND PATTERN

	Units	MILLIMETERS		
		MIN	NOM	MAX
Dimension Limits				
Contact Pitch	E	0.75 BSC		
Contact Pad Spacing	C1		9.00	
Contact Pad Spacing	C2		9.00	
Contact Pad Diameter (X169)	b		0.35	

**Notes:**

1. Dimensioning and tolerancing per ASME Y14.5M  
BSC: Basic Dimension. Theoretically exact value shown without tolerances.

**Package Outlines and Dimensions**

**169-Ball Thin Fine Pitch Ball Grid Array (7G) - 10x10x1.10 mm Body [TFBGA]  
 Alternate Terminal Assignments (does not comply with JEDEC recommendations)**

**Note:** For the most current package drawings, please see the Microchip Packaging Specification located at <http://www.microchip.com/packaging>

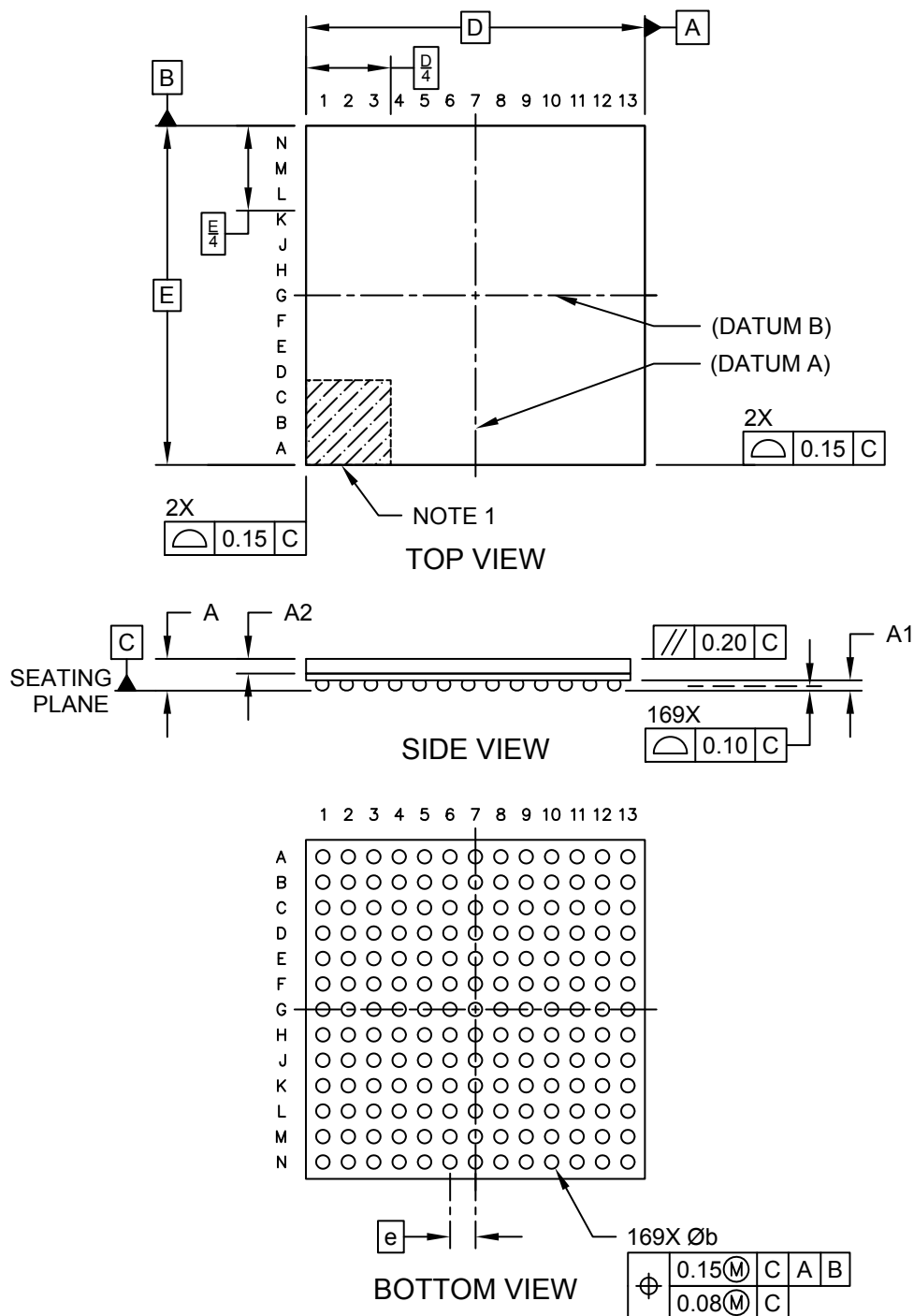

---



---

## Package Outlines and Dimensions

---



---

### 169-Ball Thin Fine Pitch Ball Grid Array (7G) - 10x10x1.10 mm Body [TFBGA] Alternate Terminal Assignments (does not comply with JEDEC recommendations)

**Note:** For the most current package drawings, please see the Microchip Packaging Specification located at <http://www.microchip.com/packaging>

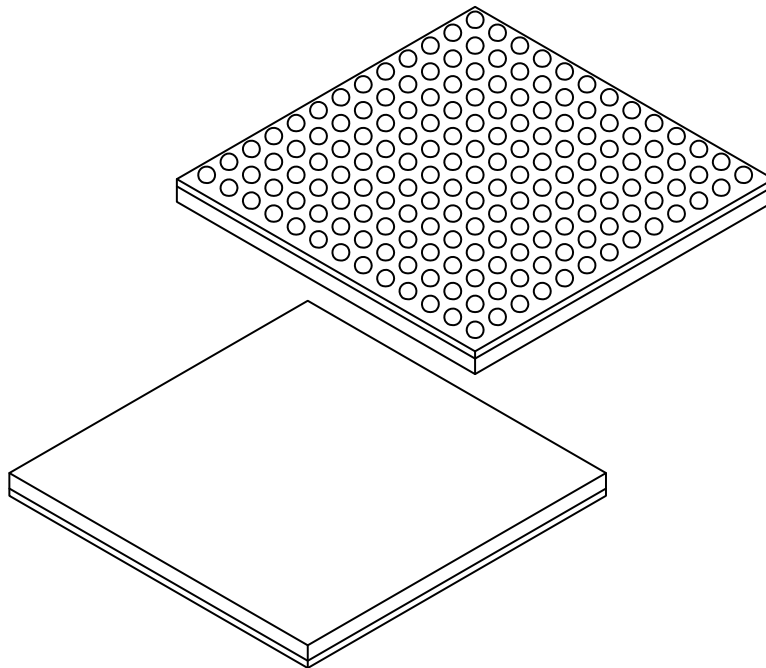

		MILLIMETERS		
Units				
Dimension Limits		MIN	NOM	MAX
Number of Terminals	N	169		
Pitch	e	0.75 BSC		
Overall Height	A	-	-	1.10
Standoff	A1	0.21	0.32	-
Mold Cap Thickness	A2	0.50	0.45	0.50
Overall Length	D	10.00		
Overall Width	E	10.00		
Ball Diameter	b	0.35	0.40	0.45

**Notes:**

1. Terminal A1 visual index feature may vary, but must be located within the hatched area.
2. Package is saw singulated
3. Dimensioning and tolerancing per ASME Y14.5M

BSC: Basic Dimension. Theoretically exact value shown without tolerances.

REF: Reference Dimension, usually without tolerance, for information purposes only.

**Footprint Outlines and Dimensions**

**169-Ball Thin Fine Pitch Ball Grid Array (7G) - 10x10x1.10 mm Body [TFBGA]  
Alternate Terminal Assignments (does not comply with JEDEC recommendations)**

**Note:** For the most current package drawings, please see the Microchip Packaging Specification located at <http://www.microchip.com/packaging>

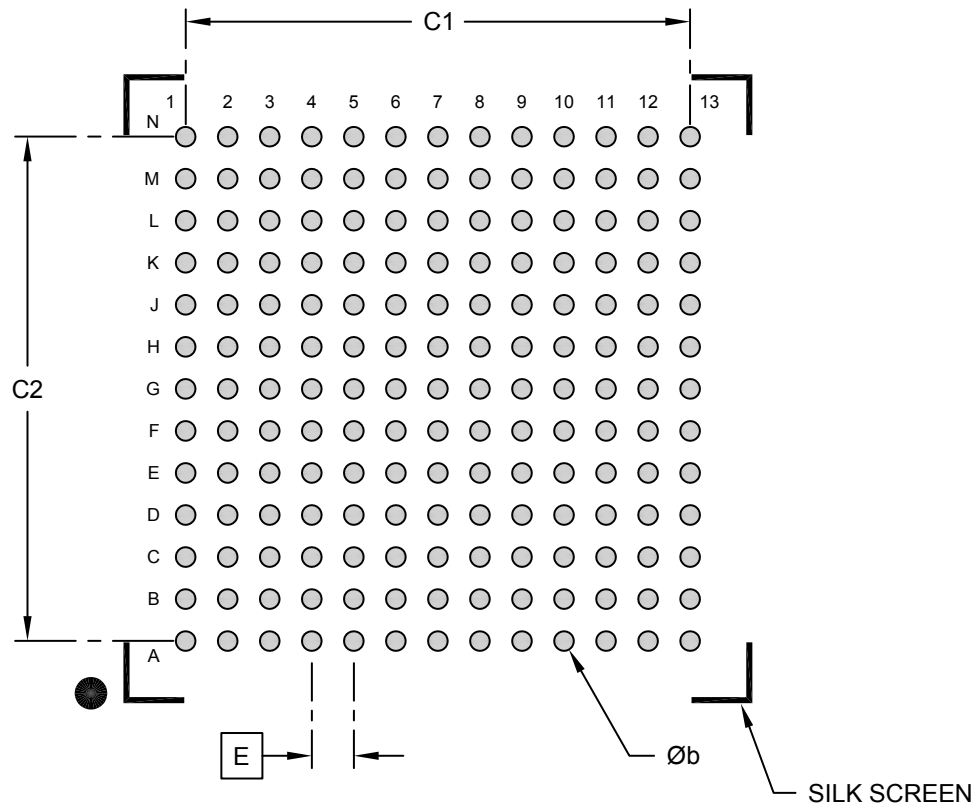

**RECOMMENDED LAND PATTERN**

Dimension Limits	Units	MILLIMETERS		
		MIN	NOM	MAX
Contact Pitch	E	0.75 BSC		
Contact Pad Spacing	C1		9.00	
Contact Pad Spacing	C2		9.00	
Contact Pad Diameter (X169)	b		0.35	

**Notes:**

1. Dimensioning and tolerancing per ASME Y14.5M  
BSC: Basic Dimension. Theoretically exact value shown without tolerances.

**Package Outlines and Dimensions**

**323-Ball Thin, Fine Pitch Ball Grid Array (HX) - 14x14x1.14 mm Body [TFBGA]**

**Note:** For the most current package drawings, please see the Microchip Packaging Specification located at <http://www.microchip.com/packaging>

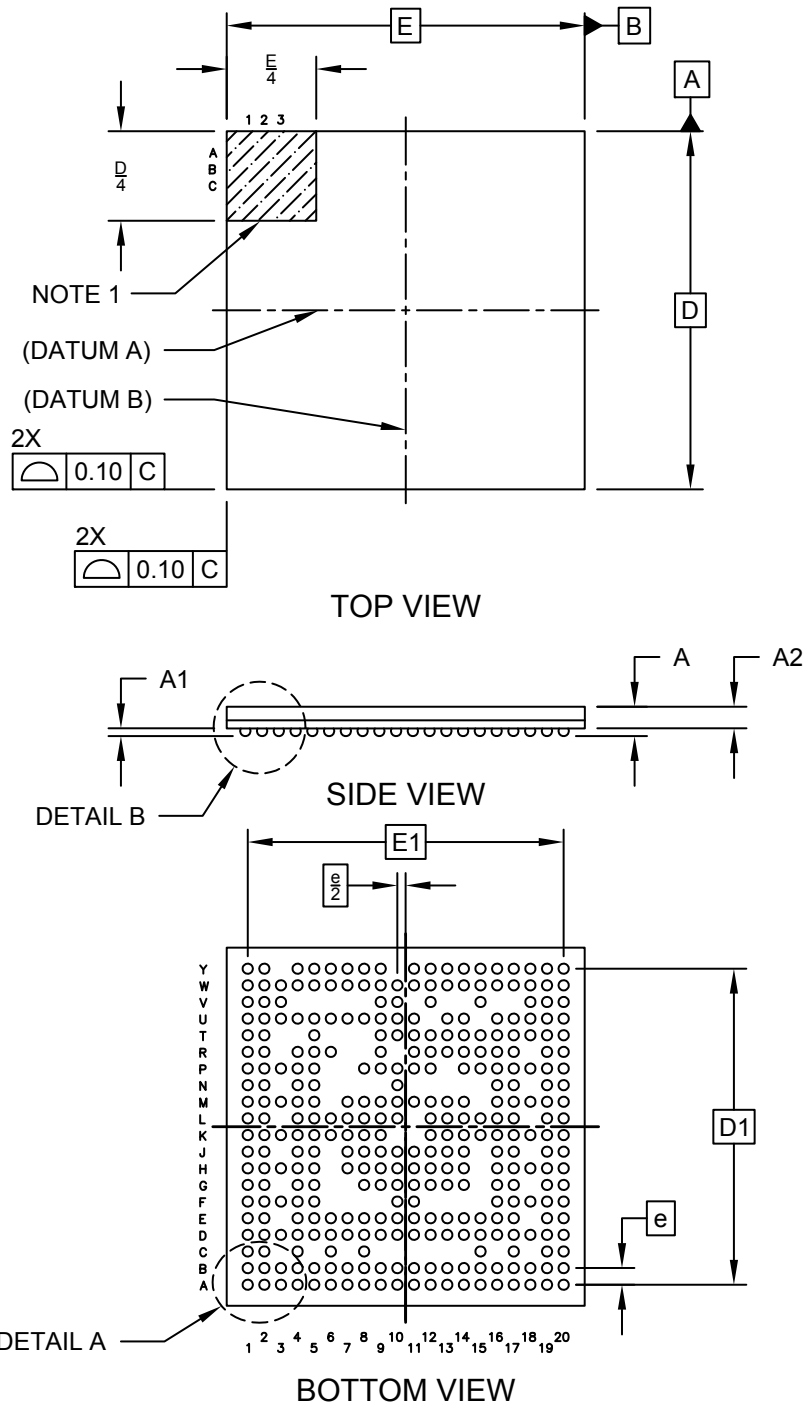

**Package Outlines and Dimensions**

**323-Ball Thin, Fine Pitch Ball Grid Array (HX) - 14x14x1.14 mm Body [TFBGA]**

**Note:** For the most current package drawings, please see the Microchip Packaging Specification located at <http://www.microchip.com/packaging>

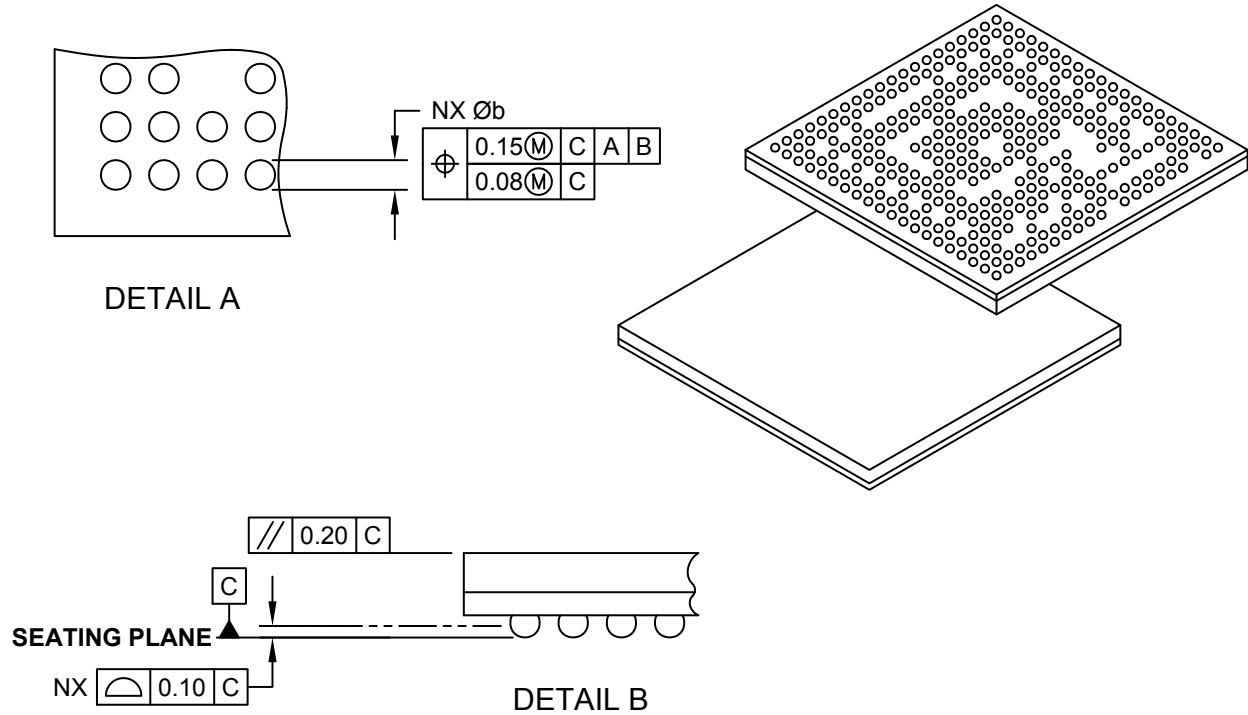

		MILLIMETERS		
Units		MIN	NOM	MAX
Dimension Limits				
Number of Balls	N	323		
Pitch	e	0.65 BSC		
Overall Height	A	-	1.04	1.14
Standoff	A1	0.21	0.31	-
Package Thickness	A2	-	0.73	-
Overall Width	E	14.00 BSC		
Overall Ball Pitch	E1	12.35 BSC		
Overall Length	D	14.00 BSC		
Overall Ball Pitch	D1	12.35 BSC		
Ball Diameter	b	0.35	0.40	0.45

**Notes:**

- Pin 1 visual index feature may vary, but must be located within the hatched area.
- Dimensioning and tolerancing per ASME Y14.5M

BSC: Basic Dimension. Theoretically exact value shown without tolerances.

REF: Reference Dimension, usually without tolerance, for information purposes only.

---

---

**Package Outlines and Dimensions**

---

---

**UFBGA**

**Package Outlines and Dimensions**

**25-Ball UltraThin Fine Pitch Ball Grid Array (FE) - 3x3 mm Body [UFBGA]**

**Note:** For the most current package drawings, please see the Microchip Packaging Specification located at <http://www.microchip.com/packaging>

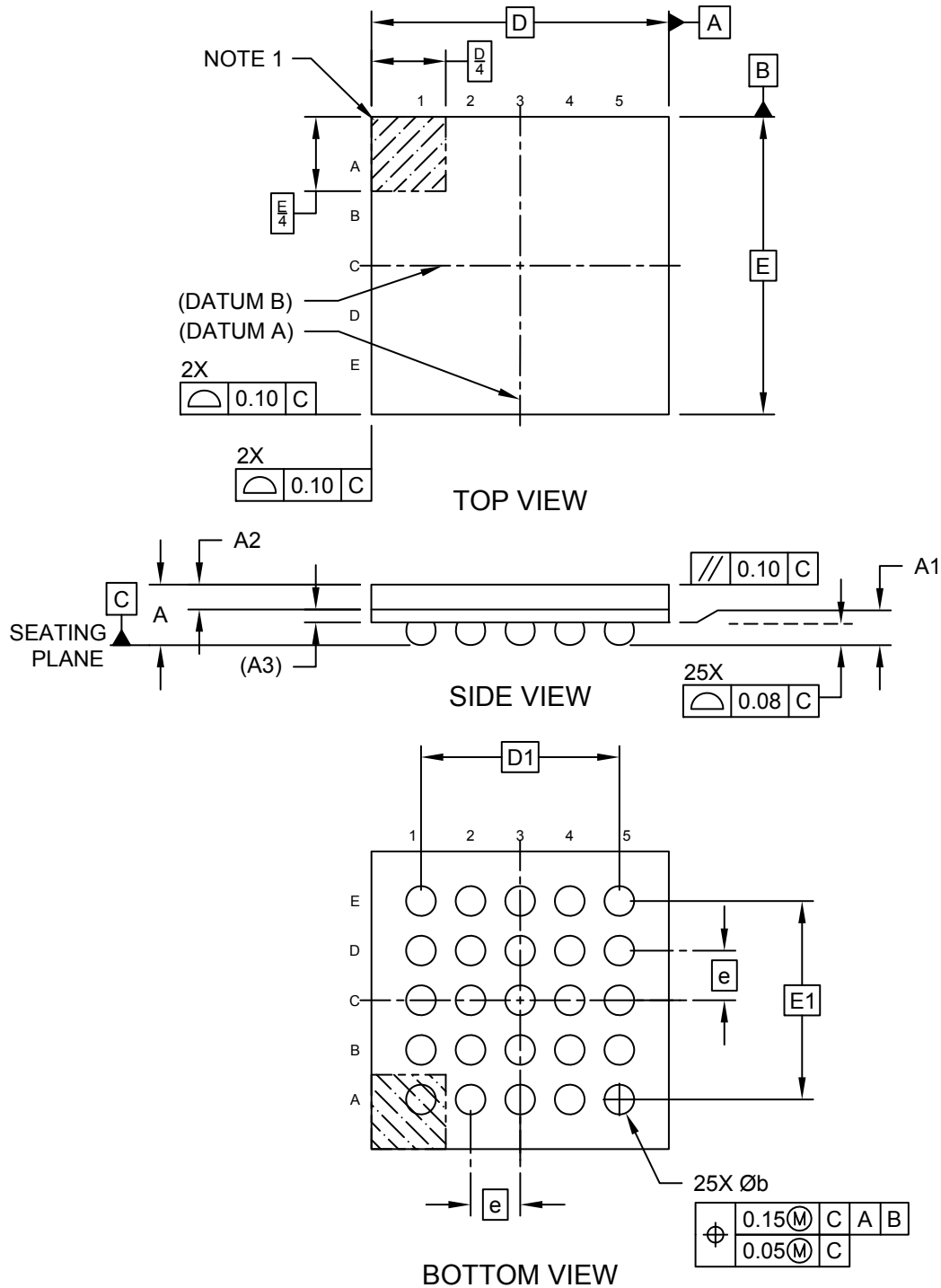



---



---

## Package Outlines and Dimensions

---



---

### 25-Ball UltraThin Fine Pitch Ball Grid Array (FE) - 3x3 mm Body [UFBGA]

**Note:** For the most current package drawings, please see the Microchip Packaging Specification located at <http://www.microchip.com/packaging>

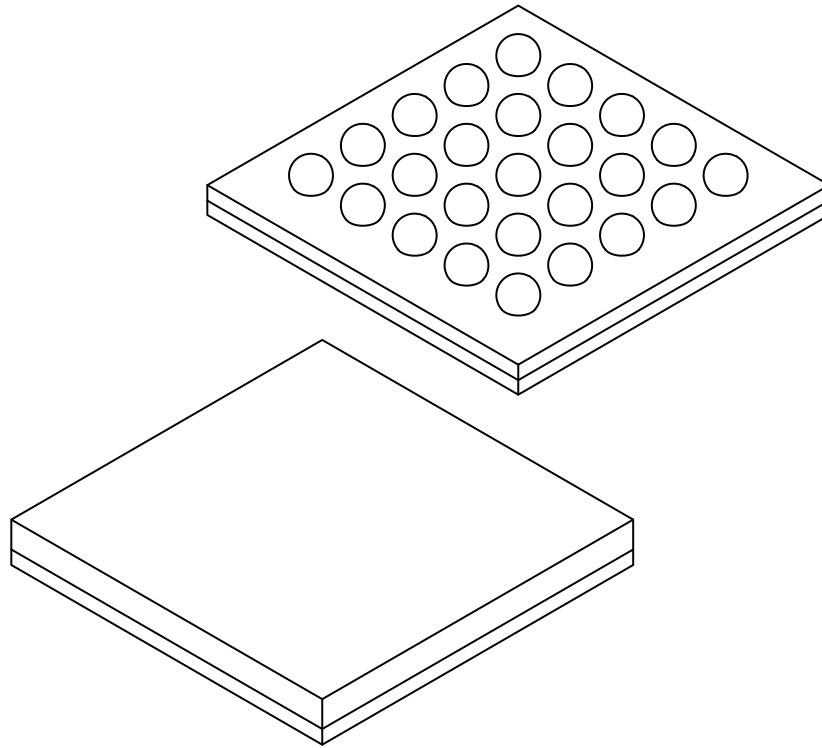

Dimension Limits	Units	MILLIMETERS		
		MIN	NOM	MAX
Number of Terminals	N	25		
Pitch	e	0.50 BSC		
Overall Height	A	0.51	0.61	0.71
Standoff	A1	0.18	0.23	0.28
Mold Thickness	A2	0.22	0.25	0.28
Substrate Thickness	A3	0.13 REF		
Overall Length	D	3.00 BSC		
Overall Terminal Spacing	D1	2.00 BSC		
Overall Width	E	3.00 BSC		
Overall Terminal Spacing	E1	2.00 BSC		
Terminal Diameter	b	0.25	0.30	0.35

**Notes:**

1. Pin 1 visual index feature may vary, but must be located within the hatched area.
2. Dimensioning and tolerancing per ASME Y14.5M
  - BSC: Basic Dimension. Theoretically exact value shown without tolerances.
  - REF: Reference Dimension, usually without tolerance, for information purposes only.

**Footprint Outlines and Dimensions**

**25-Ball UltraThin Fine Pitch Ball Grid Array (FE) - 3x3 mm Body [UFBGA]**

**Note:** For the most current package drawings, please see the Microchip Packaging Specification located at <http://www.microchip.com/packaging>

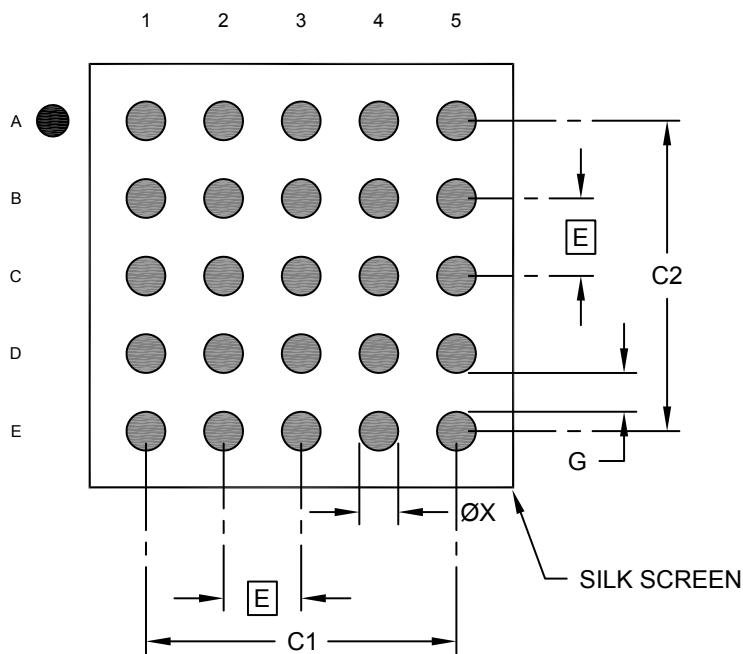

**RECOMMENDED LAND PATTERN**

Dimension Limits	Units	MILLIMETERS		
		MIN	NOM	MAX
Contact Pitch	E	0.50 BSC		
Overall Contact Pad Spacing	C1		2.00	
Overall Contact Pad Spacing	C2		2.00	
Contact Pad Width (X25)	X1			0.25
Contact Pad to Contact Pad	G	0.25		

**Notes:**

1. Dimensioning and tolerancing per ASME Y14.5M  
BSC: Basic Dimension. Theoretically exact value shown without tolerances.

---

---

**Package Outlines and Dimensions**

---

---

**VFBGA**

**Package Outlines and Dimensions**

**61-Ball Very Thin Fine Pitch Ball Grid Array (5HX) - 5x5x0.9 mm Body [VFBGA]**

**Note:** For the most current package drawings, please see the Microchip Packaging Specification located at <http://www.microchip.com/packaging>

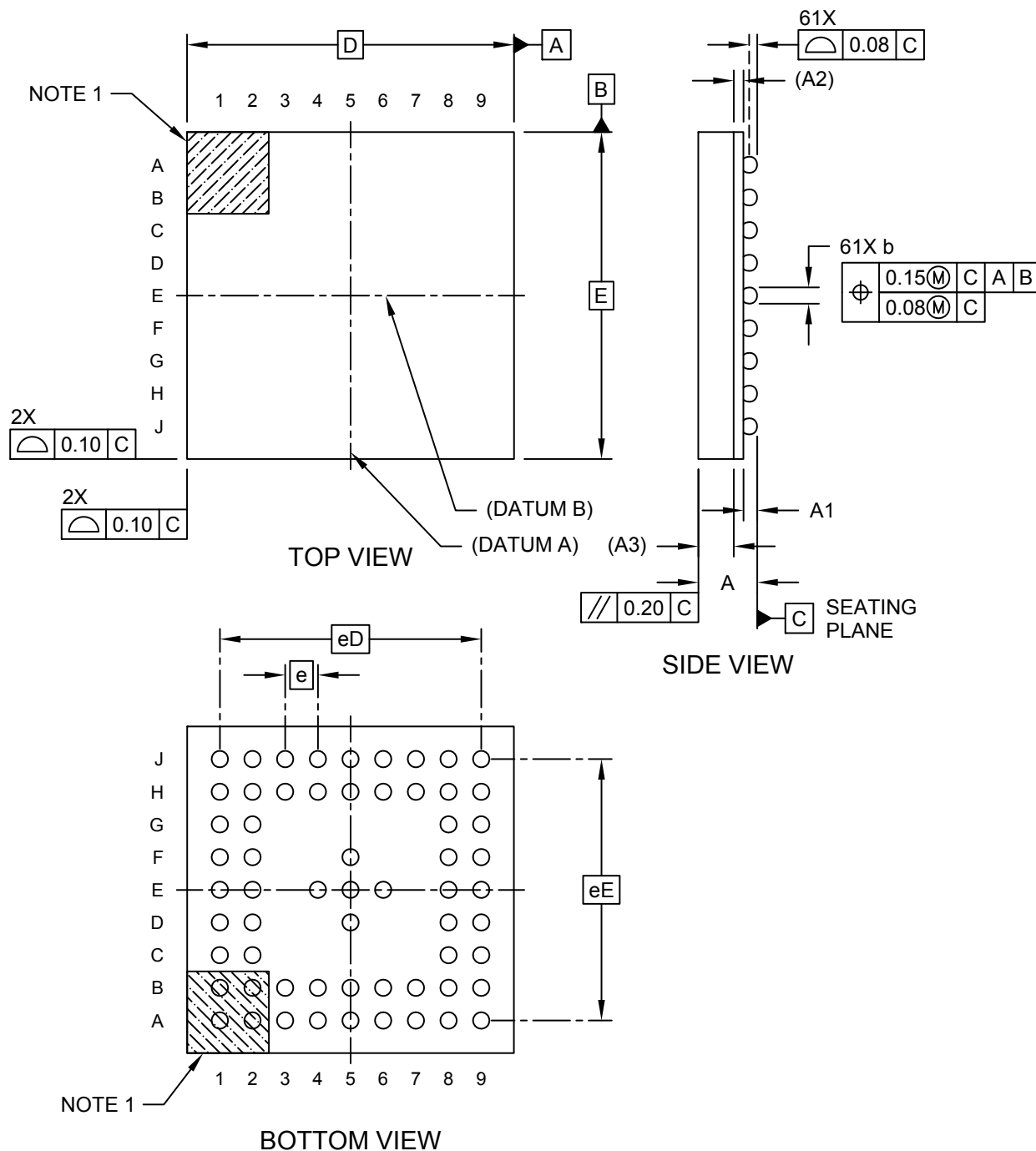

---



---

## Package Outlines and Dimensions

---



---

### 61-Ball Very Thin Fine Pitch Ball Grid Array (5HX) - 5x5x0.9 mm Body [VFBGA]

**Note:** For the most current package drawings, please see the Microchip Packaging Specification located at <http://www.microchip.com/packaging>

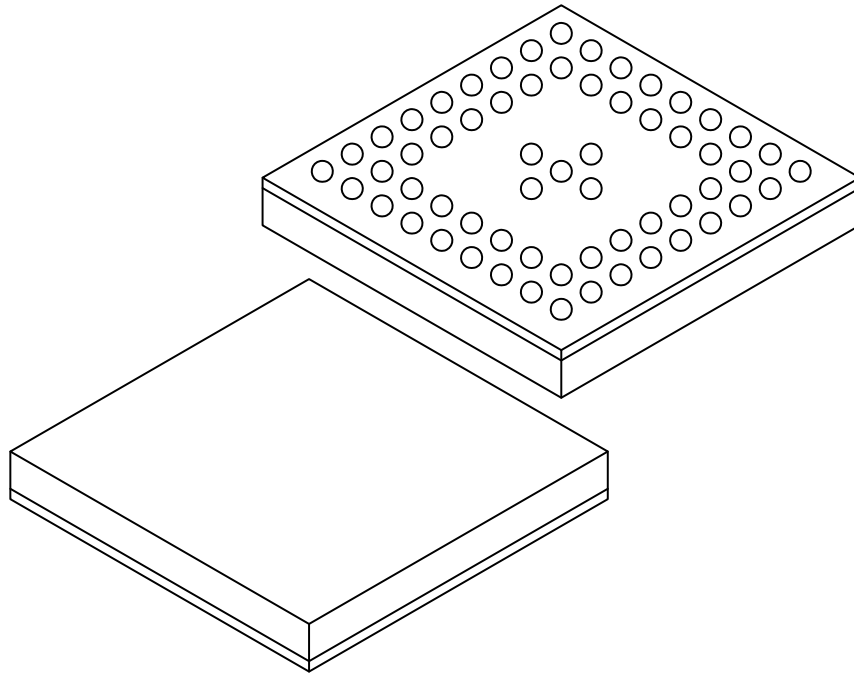

		Units	MILLIMETERS		
Dimension Limits			MIN	NOM	MAX
Number of Terminals	N	61			
Pitch	e	0.50 BSC			
Overall Height	A	-	-	0.90	
Standoff	A1	0.11	-		
Standoff	A2	0.125 REF			
Terminal Thickness	A3	0.54 REF			
Overall Length	D	5.00 BSC			
Overall Pitch	eD	4.00 BSC			
Overall Width	E	5.00 BSC			
Overall Pitch	eE	4.00 BSC			
Terminal Diameter	b	0.20	0.25	0.30	

**Notes:**

1. Terminal A1 visual index feature may vary, but must be located within the hatched area.
2. Dimensioning and tolerancing per ASME Y14.5M

BSC: Basic Dimension. Theoretically exact value shown without tolerances.

REF: Reference Dimension, usually without tolerance, for information purposes only.

**Footprint Outlines and Dimensions**

**61-Ball Very Thin Fine Pitch Ball Grid Array (5HX) - 5x5x0.9 mm Body [VFBGA]**

**Note:** For the most current package drawings, please see the Microchip Packaging Specification located at <http://www.microchip.com/packaging>

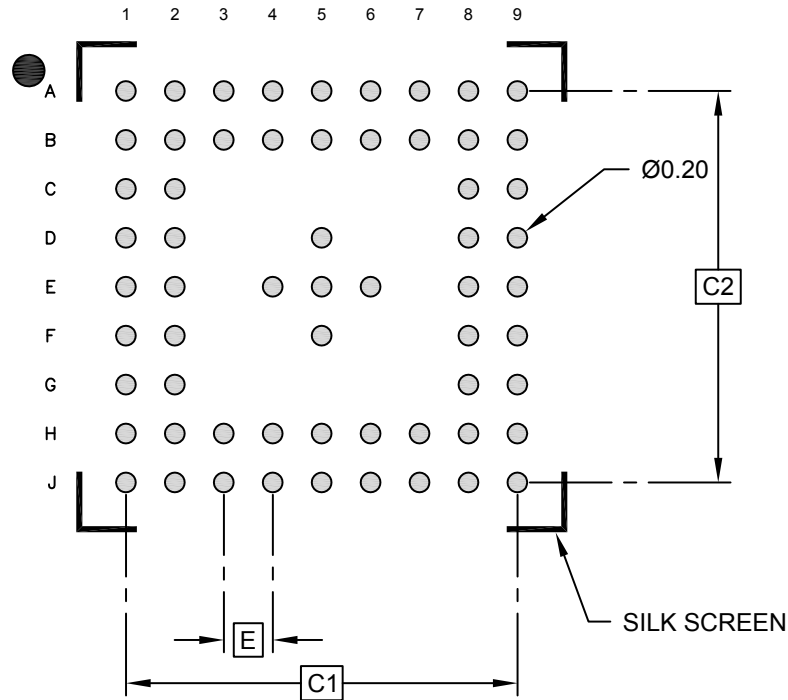

**RECOMMENDED LAND PATTERN**

Dimension Limits	Units	MILLIMETERS		
		MIN	NOM	MAX
Contact Pitch	E	0.50 BSC		
Contact Pad Spacing	C1		4.00	
Contact Pad Spacing	C2		4.00	
Contact Pad Diameter (X61)	X1			0.20

**Notes:**

1. Dimensioning and tolerancing per ASME Y14.5M  
BSC: Basic Dimension. Theoretically exact value shown without tolerances.

**Package Outlines and Dimensions**

**64-Ball Very Thin Fine Pitch Ball Grid Array (4G) - 7x7x1.0 mm Body [VFPGA]**

**Note:** For the most current package drawings, please see the Microchip Packaging Specification located at <http://www.microchip.com/packaging>

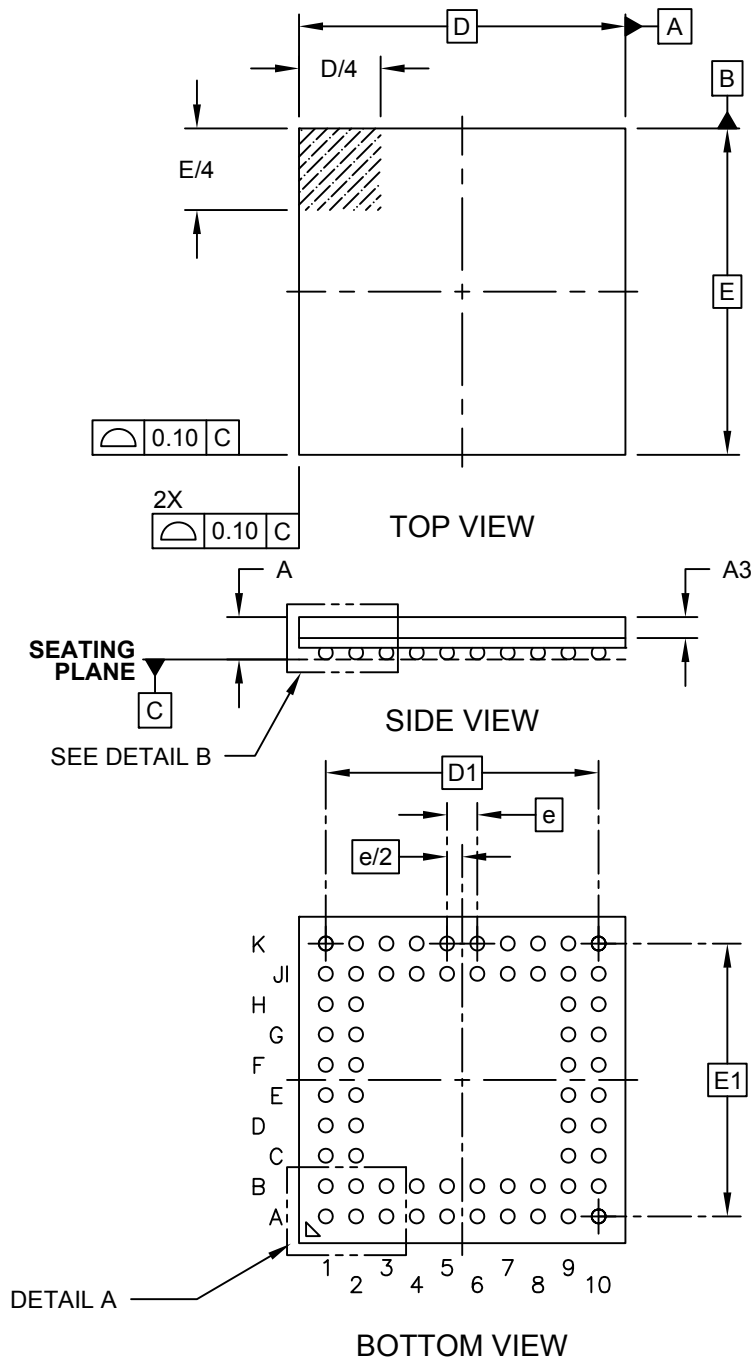

**Package Outlines and Dimensions**

**64-Ball Very Thin Fine Pitch Ball Grid Array (4G) - 7x7x1.0 mm Body [VFBGA]**

**Note:** For the most current package drawings, please see the Microchip Packaging Specification located at <http://www.microchip.com/packaging>

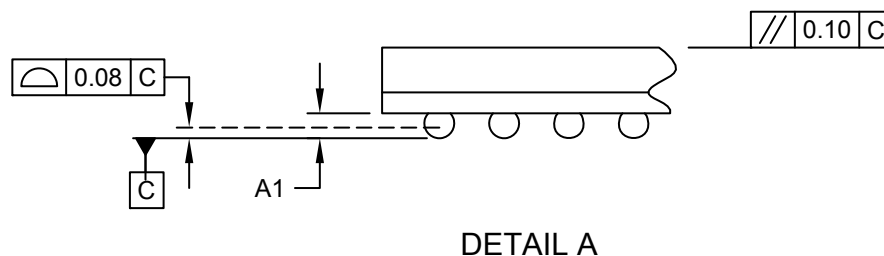
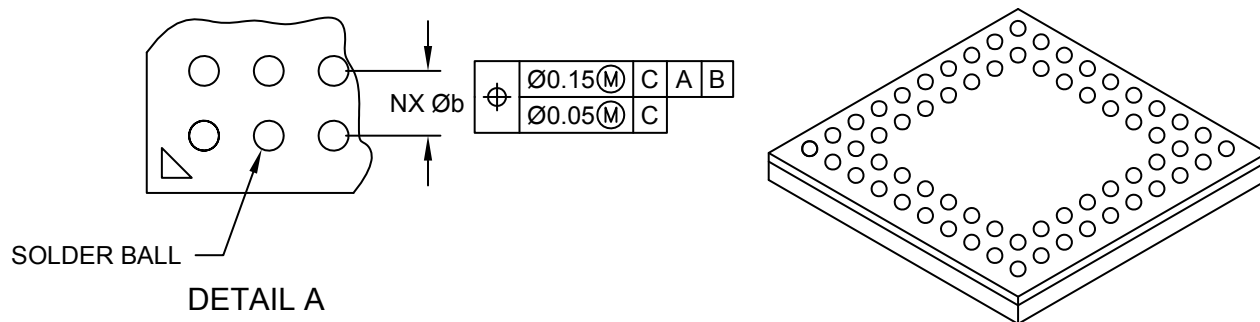

Dimension Limits	Units	MILLIMETERS		
		MIN	NOM	MAX
Number of Pins	N	64		
Pitch	e	0.65 BSC		
Overall Height	A	-	-	1.00
Standoff	A1	0.16	-	0.25
Molded Cap Thickness	A3	0.45 REF		
Overall Width	E	7.00 BSC		
Overall Ball Pitch	E1	5.85 BSC		
Overall Length	D	7.00 BSC		
Overall Ball Pitch	D1	5.85 BSC		
Ball Diameter	Øb	0.25	0.30	0.35

**Notes:**

- Pin 1 visual index feature may vary, but must be located within the hatched area.
- Dimensioning and tolerancing per ASME Y14.5M  
 BSC: Basic Dimension. Theoretically exact value shown without tolerances.  
 REF: Reference Dimension, usually without tolerance, for information purposes only.



---



---

## Footprint Outlines and Dimensions

---



---

### 64-Ball Very Thin Fine Pitch Ball Grid Array (4G) - 7x7x1.0 mm Body [VFPGA]

**Note:** For the most current package drawings, please see the Microchip Packaging Specification located at <http://www.microchip.com/packaging>

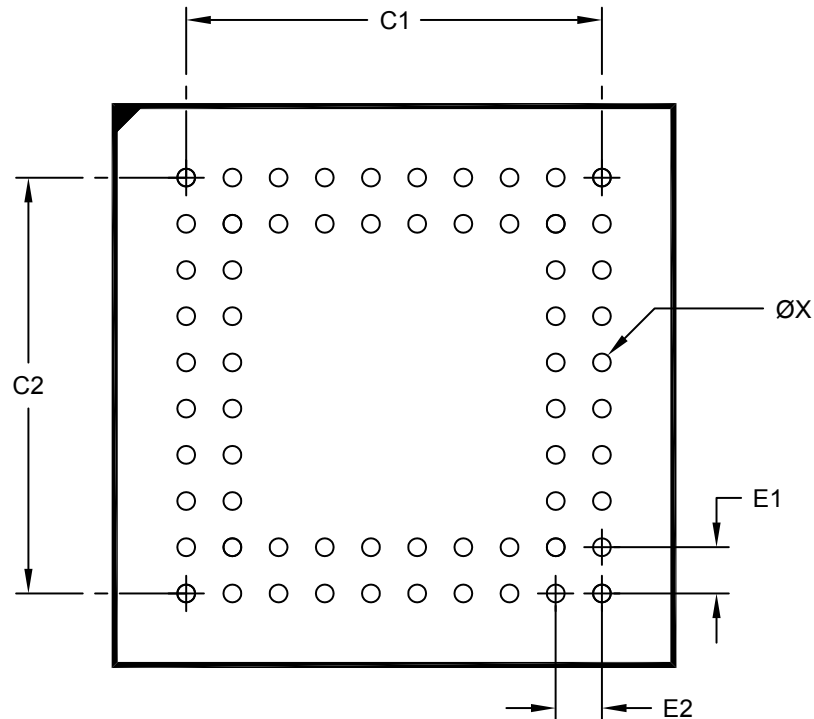

### RECOMMENDED LAND PATTERN

	Units	MILLIMETERS		
		MIN	NOM	MAX
Contact Pitch	E1		0.65 BSC	
Contact Pitch	E2		0.65 BSC	
Contact Pad Spacing	C1		5.85	
Contact Pad Spacing	C2		5.85	
Contact Pad Diameter (X64)	X		0.25	

**Notes:**

1. Dimensioning and tolerancing per ASME Y14.5M

BSC: Basic Dimension. Theoretically exact value shown without tolerances.

Microchip Technology Drawing C04-2370A

**Package Outlines and Dimensions**

**64-Ball Very Thin Fine Pitch Ball Grid Array (GA) - 7x7x1.0 mm Body [VFBGA]  
Supertex Legacy**

**Note:** For the most current package drawings, please see the Microchip Packaging Specification located at <http://www.microchip.com/packaging>

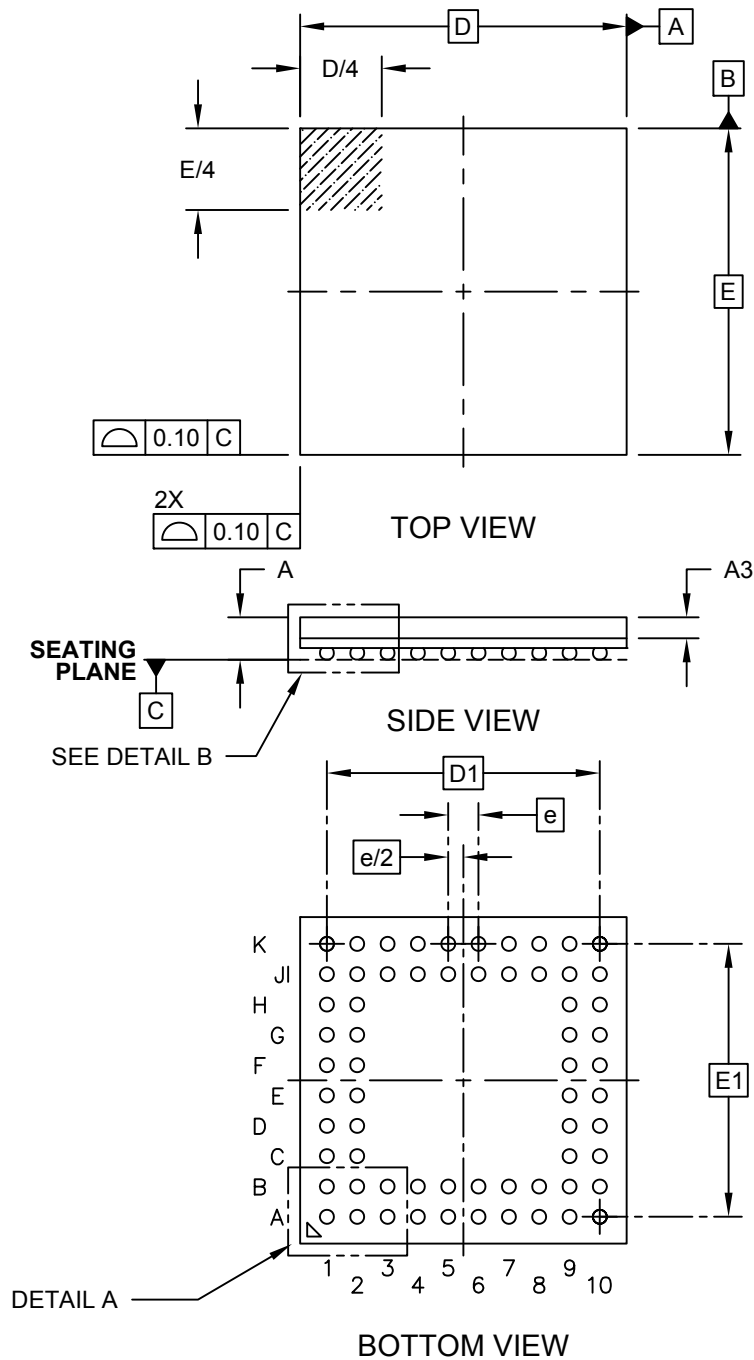

---



---

## Package Outlines and Dimensions

---



---

### 64-Ball Very Thin Fine Pitch Ball Grid Array (GA) - 7x7x1.0 mm Body [VFBGA] Supertex Legacy

**Note:** For the most current package drawings, please see the Microchip Packaging Specification located at <http://www.microchip.com/packaging>

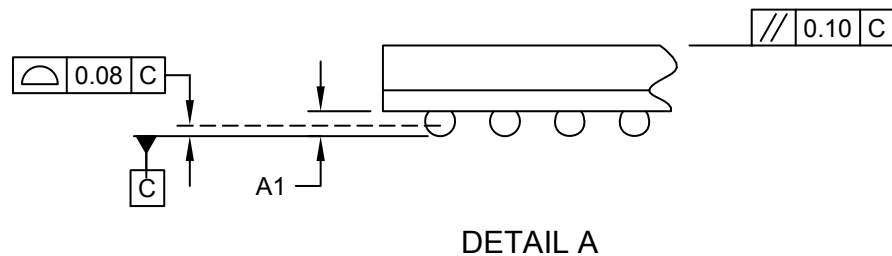
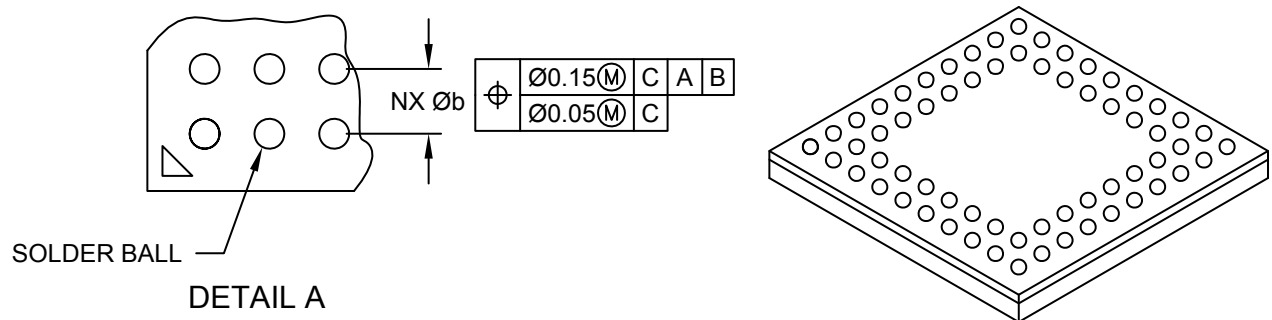

	Units	MILLIMETERS		
		MIN	NOM	MAX
Number of Pins	N	64		
Pitch	e	0.65 BSC		
Overall Height	A	-	-	1.00
Standoff	A1	0.16	-	0.25
Molded Cap Thickness	A3	0.45 REF		
Overall Width	E	7.00 BSC		
Overall Ball Pitch	E1	5.85 BSC		
Overall Length	D	7.00 BSC		
Overall Ball Pitch	D1	5.85 BSC		
Ball Diameter	$\varnothing b$	0.25	0.30	0.35

**Notes:**

1. Pin 1 visual index feature may vary, but must be located within the hatched area.
2. Dimensioning and tolerancing per ASME Y14.5M
  - BSC: Basic Dimension. Theoretically exact value shown without tolerances.
  - REF: Reference Dimension, usually without tolerance, for information purposes only.

**Footprint Outlines and Dimensions**

**64-Ball Very Thin Fine Pitch Ball Grid Array (GA) - 7x7x1.0 mm Body [VFBGA]**

**Note:** For the most current package drawings, please see the Microchip Packaging Specification located at <http://www.microchip.com/packaging>

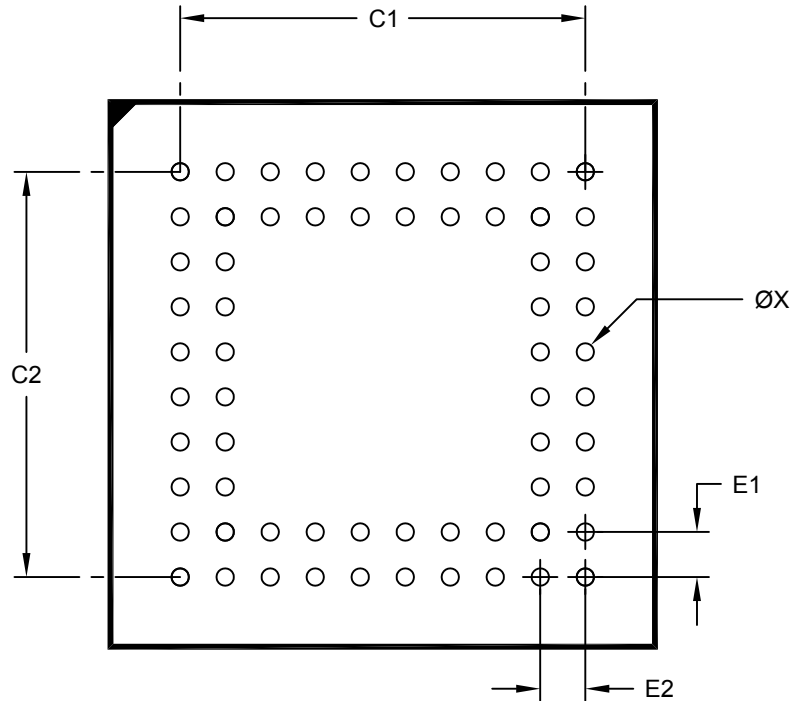

**RECOMMENDED LAND PATTERN**

Units		MILLIMETERS		
Dimension Limits		MIN	NOM	MAX
Contact Pitch	E1	0.65 BSC		
Contact Pitch	E2	0.65 BSC		
Contact Pad Spacing	C1		5.85	
Contact Pad Spacing	C2		5.85	
Contact Pad Diameter (X64)	X		0.25	

**Notes:**

1. Dimensioning and tolerancing per ASME Y14.5M

BSC: Basic Dimension. Theoretically exact value shown without tolerances.

Microchip Technology Drawing C04-2370-GA Rev A

**Package Outlines and Dimensions**

**78-Ball Very Thin Fine Pitch Ball Grid Array (5G) - 9x9x1.0 mm Body [VFBGA]**

**Note:** For the most current package drawings, please see the Microchip Packaging Specification located at <http://www.microchip.com/packaging>

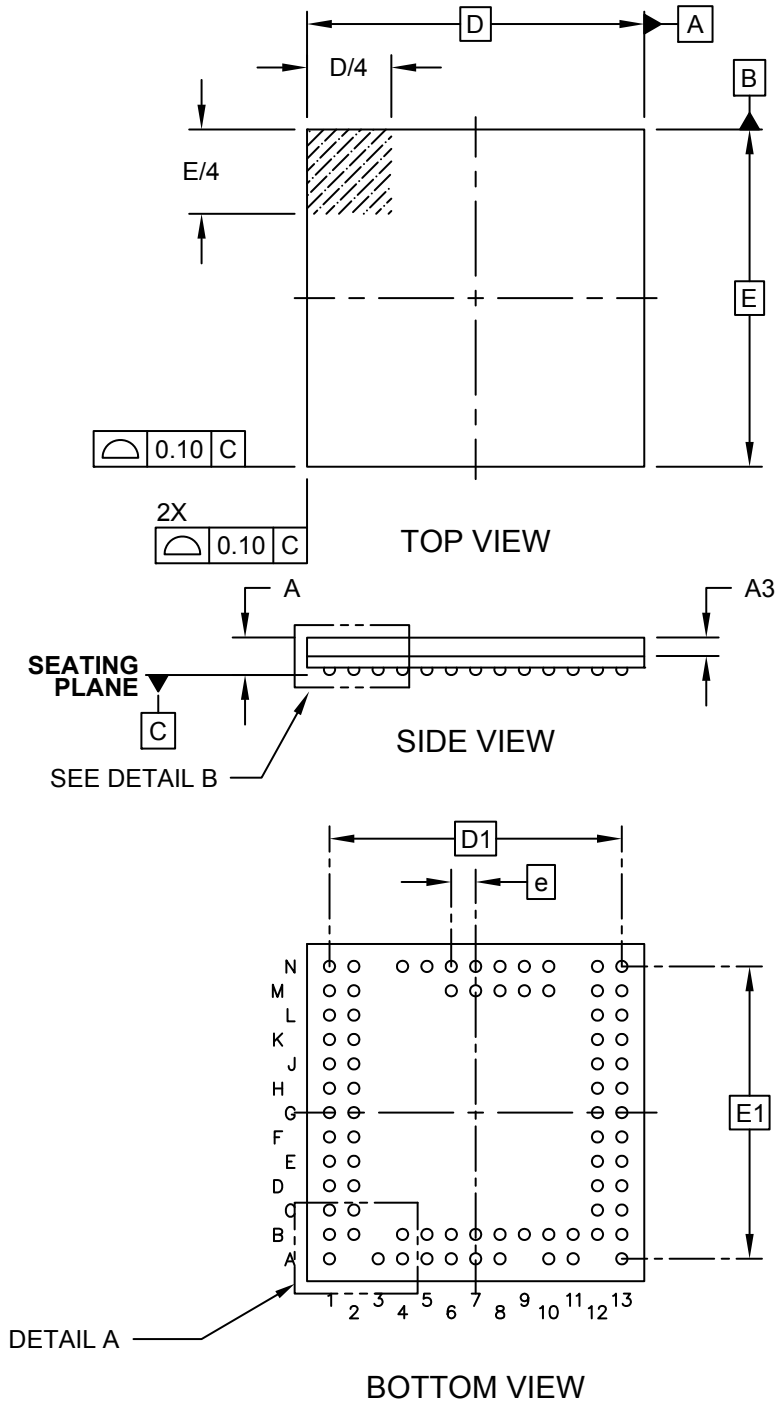

**Package Outlines and Dimensions**

**78-Ball Very Thin Fine Pitch Ball Grid Array (5G) - 9x9x1.0 mm Body [VFPGA]**

**Note:** For the most current package drawings, please see the Microchip Packaging Specification located at <http://www.microchip.com/packaging>

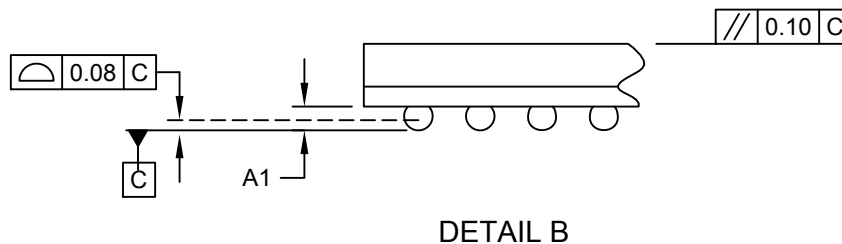
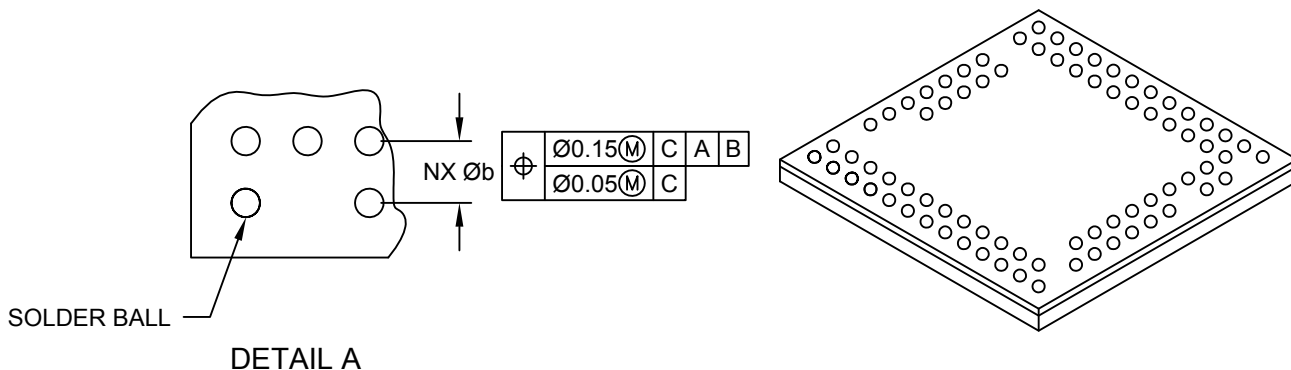

Dimension Limits	Units	MILLIMETERS		
		MIN	NOM	MAX
Number of Pins	N	78		
Pitch	e	0.65 BSC		
Overall Height	A	-	-	1.00
Standoff	A1	0.15	0.20	0.25
Molded Cap Thickness	A3	0.45	0.50	0.55
Overall Width	E	9.00 BSC		
Overall Ball Pitch	E1	7.80 BSC		
Overall Length	D	9.00 BSC		
Overall Ball Pitch	D1	7.80 BSC		
Ball Diameter	Øb	0.25	0.30	0.35

**Notes:**

1. Pin 1 visual index feature may vary, but must be located within the hatched area.
2. Dimensioning and tolerancing per ASME Y14.5M

BSC: Basic Dimension. Theoretically exact value shown without tolerances.

REF: Reference Dimension, usually without tolerance, for information purposes only.

---



---

## Footprint Outlines and Dimensions

---



---

### 78-Ball Very Thin Fine Pitch Ball Grid Array (5G) - 9x9x1.0 mm Body [VFBGA]

**Note:** For the most current package drawings, please see the Microchip Packaging Specification located at <http://www.microchip.com/packaging>

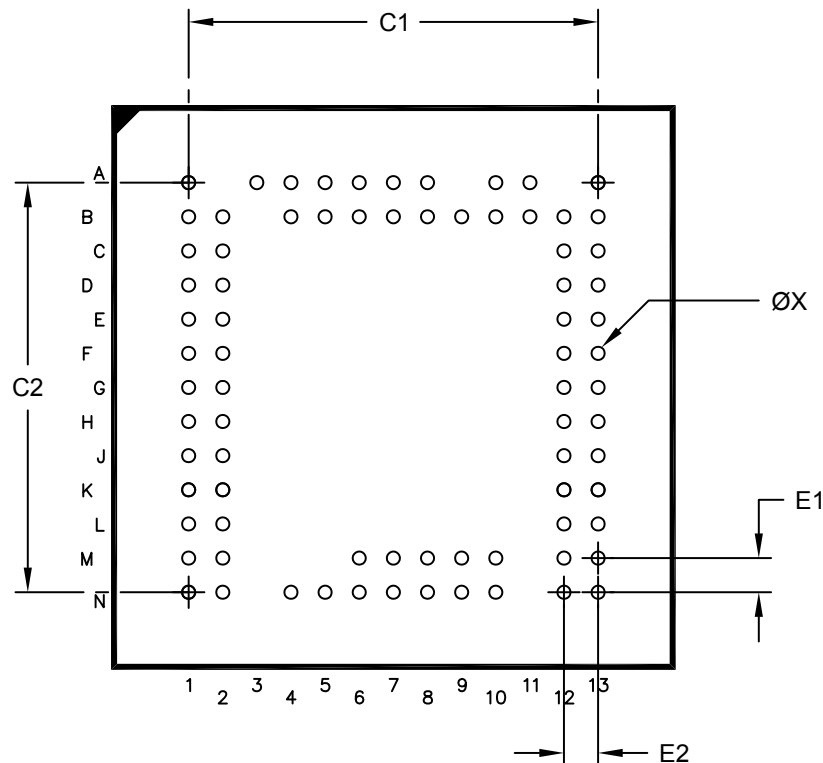

**RECOMMENDED LAND PATTERN**

	Units	MILLIMETERS		
		MIN	NOM	MAX
Contact Pitch	E1	0.65 BSC		
Contact Pitch	E2	0.65 BSC		
Contact Pad Spacing	C1		780	
Contact Pad Spacing	C2		7.80	
Contact Pad Diameter (X78)	X		0.25	

**Notes:**

1. Dimensioning and tolerancing per ASME Y14.5M

BSC: Basic Dimension. Theoretically exact value shown without tolerances.

Microchip Technology Drawing C04-2371-5G Rev B

**Package Outlines and Dimensions**

**78-Ball Very Thin Fine Pitch Ball Grid Array (GA) - 9x9x1.0 mm Body [VFPGA]  
Supertex Legacy**

**Note:** For the most current package drawings, please see the Microchip Packaging Specification located at <http://www.microchip.com/packaging>

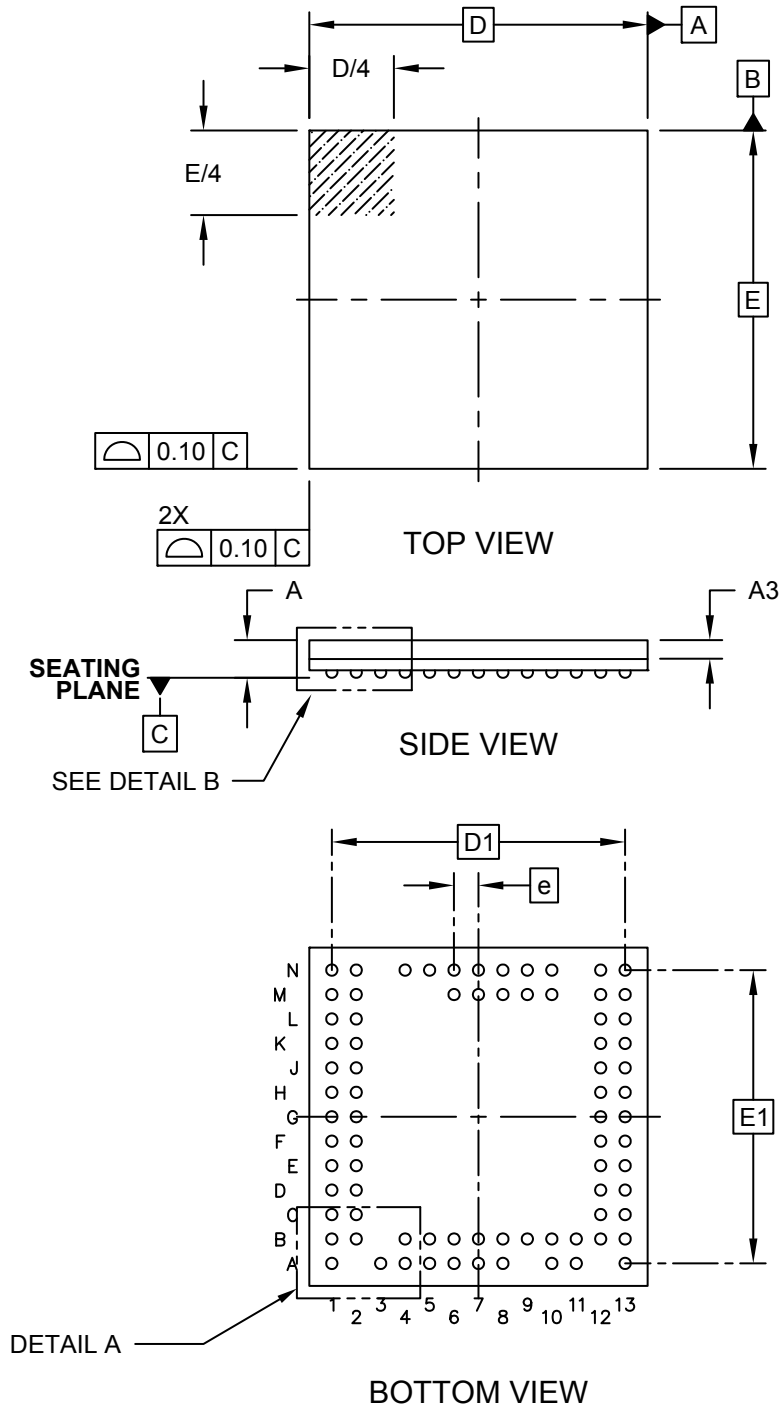



## Package Outlines and Dimensions

### 78-Ball Very Thin Fine Pitch Ball Grid Array (GA) - 9x9x1.0 mm Body [VFPGA] Supertex Legacy

**Note:** For the most current package drawings, please see the Microchip Packaging Specification located at <http://www.microchip.com/packaging>

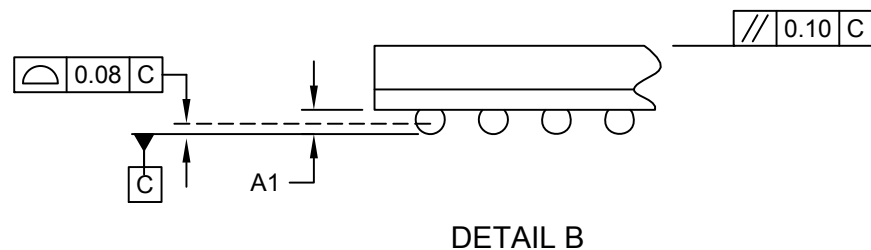
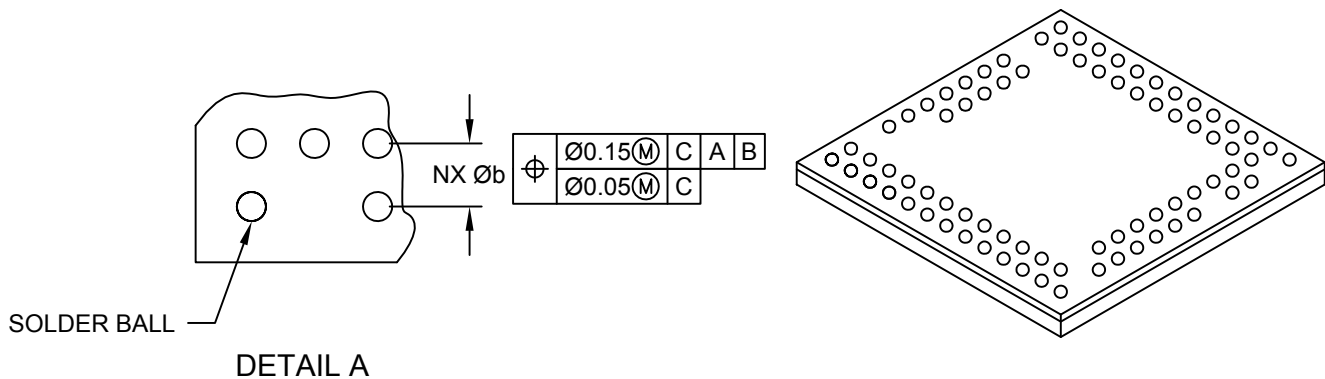

Dimension Limits	Units	MILLIMETERS		
		MIN	NOM	MAX
Number of Pins	N	78		
Pitch	e	0.65 BSC		
Overall Height	A	-	-	1.00
Standoff	A1	0.15	0.20	0.25
Molded Cap Thickness	A3	0.45	0.50	0.55
Overall Width	E	9.00 BSC		
Overall Ball Pitch	E1	7.80 BSC		
Overall Length	D	9.00 BSC		
Overall Ball Pitch	D1	7.80 BSC		
Ball Diameter	Øb	0.25	0.30	0.35

**Notes:**

- Pin 1 visual index feature may vary, but must be located within the hatched area.
- Dimensioning and tolerancing per ASME Y14.5M

BSC: Basic Dimension. Theoretically exact value shown without tolerances.

REF: Reference Dimension, usually without tolerance, for information purposes only.

**Footprint Outlines and Dimensions**

**78-Ball Very Thin Fine Pitch Ball Grid Array (GA) - 9x9x1.0 mm Body [VFBGA]  
Supertex Legacy**

**Note:** For the most current package drawings, please see the Microchip Packaging Specification located at <http://www.microchip.com/packaging>

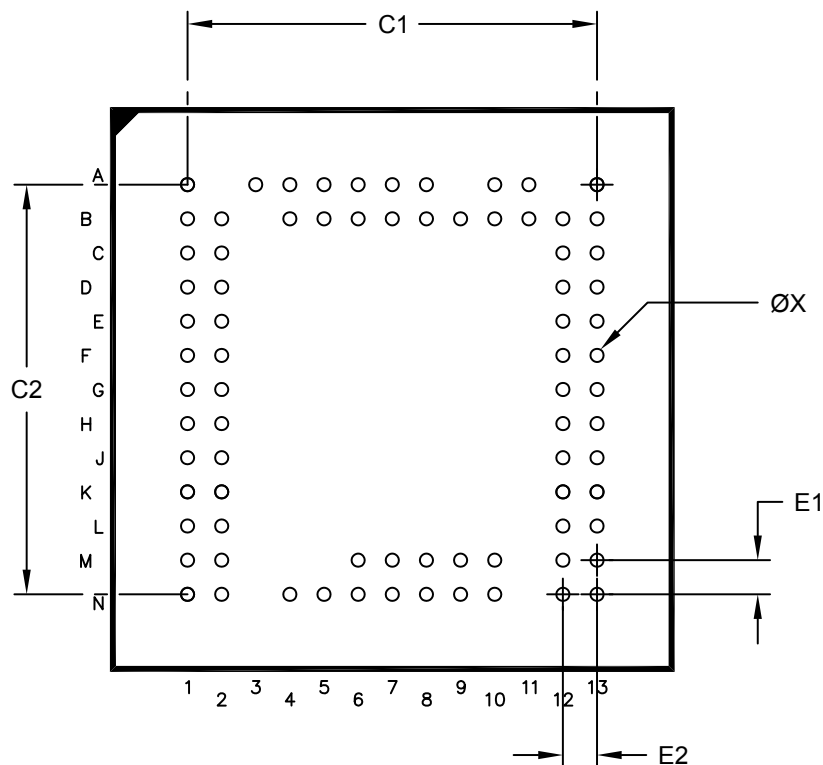

**RECOMMENDED LAND PATTERN**

Dimension Limits	Units	MILLIMETERS		
		MIN	NOM	MAX
Contact Pitch	E1	0.65 BSC		
Contact Pitch	E2	0.65 BSC		
Contact Pad Spacing	C1		780	
Contact Pad Spacing	C2		7.80	
Contact Pad Diameter (X78)	X		0.25	

**Notes:**

1. Dimensioning and tolerancing per ASME Y14.5M

BSC: Basic Dimension. Theoretically exact value shown without tolerances.

Microchip Technology Drawing C04-2371-GA Rev B

---

---

**Package Outlines and Dimensions**

---

---

**WFBGA**

**Package Outlines and Dimensions**

**64-Ball Very, Very Thin Fine Pitch Ball Grid Array (7U) - 6x6 mm Body [WFBGA]**

**Note:** For the most current package drawings, please see the Microchip Packaging Specification located at <http://www.microchip.com/packaging>

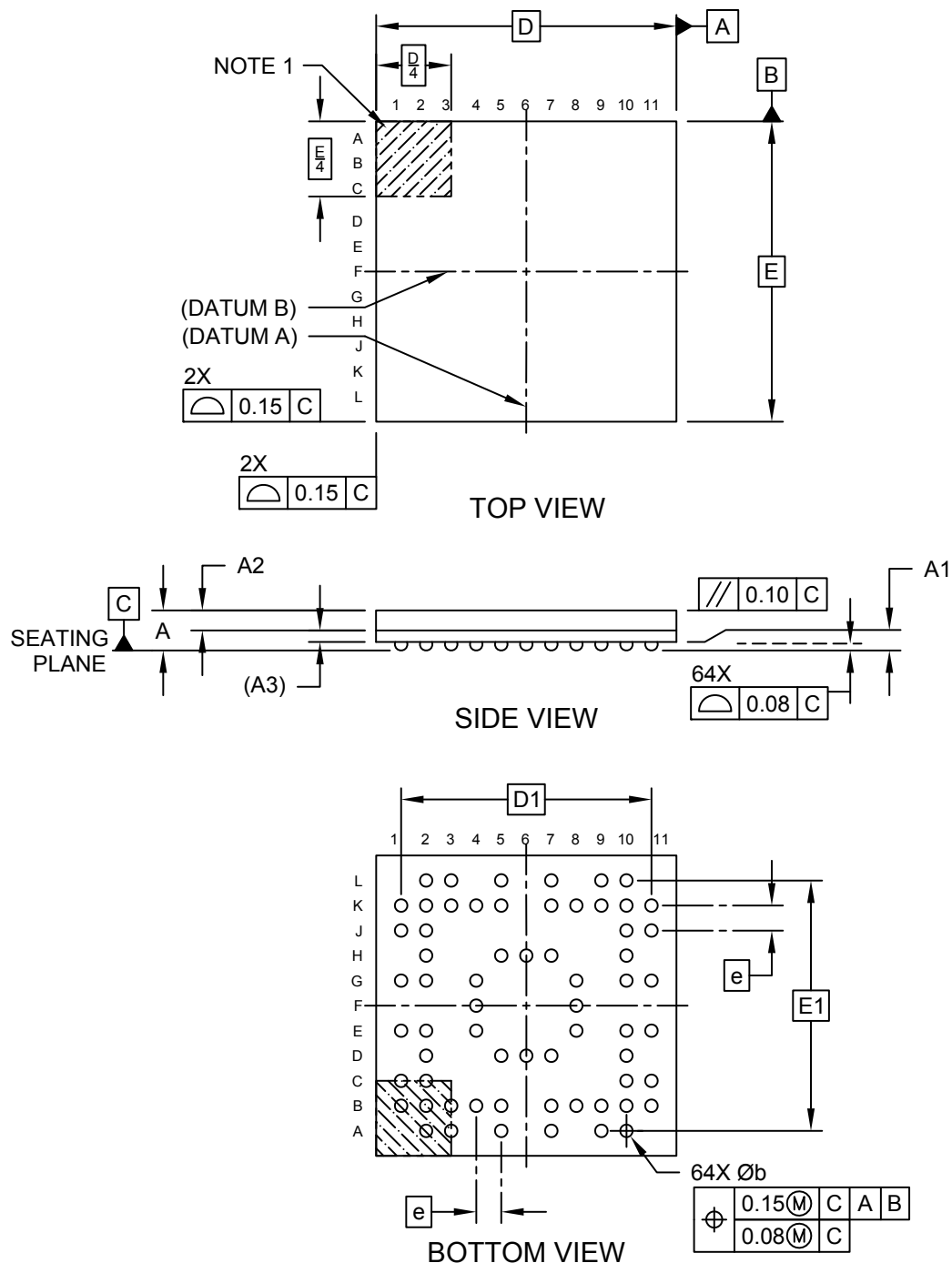

---



---

## Package Outlines and Dimensions

---



---

### 64-Ball Very, Very Thin Fine Pitch Ball Grid Array (7U) - 6x6 mm Body [WFBGA]

**Note:** For the most current package drawings, please see the Microchip Packaging Specification located at <http://www.microchip.com/packaging>

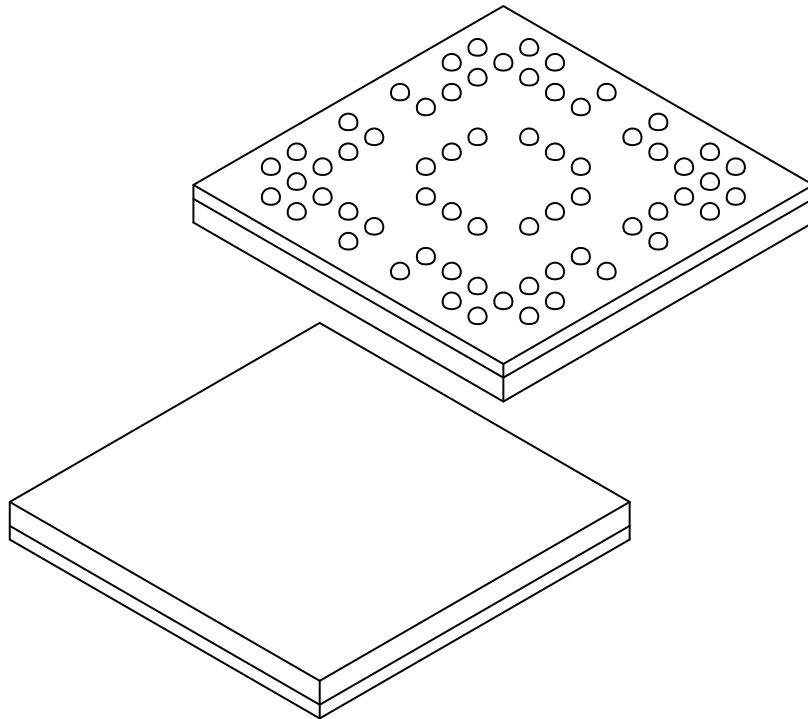

	Units	MILLIMETERS		
		MIN	NOM	MAX
Number of Terminals	N	64		
Pitch	e	0.50 BSC		
Overall Height	A	-	-	0.80
Standoff	A1	0.12	0.17	-
Mold Thickness	A2	0.35	0.40	0.45
Substrate Thickness	A3	0.26 REF		
Overall Length	D	6.00 BSC		
Overall Terminal Spacing	D1	5.00 BSC		
Overall Width	E	6.00 BSC		
Overall Terminal Spacing	E1	5.00 BSC		
Terminal Diameter	b	0.20	0.25	0.30

**Notes:**

1. Pin 1 visual index feature may vary, but must be located within the hatched area.
2. Dimensioning and tolerancing per ASME Y14.5M
  - BSC: Basic Dimension. Theoretically exact value shown without tolerances.
  - REF: Reference Dimension, usually without tolerance, for information purposes only.

**Footprint Outlines and Dimensions**

**64-Ball Very, Very Thin Fine Pitch Ball Grid Array (7U) - 6x6 mm Body [WFBGA]**

**Note:** For the most current package drawings, please see the Microchip Packaging Specification located at <http://www.microchip.com/packaging>

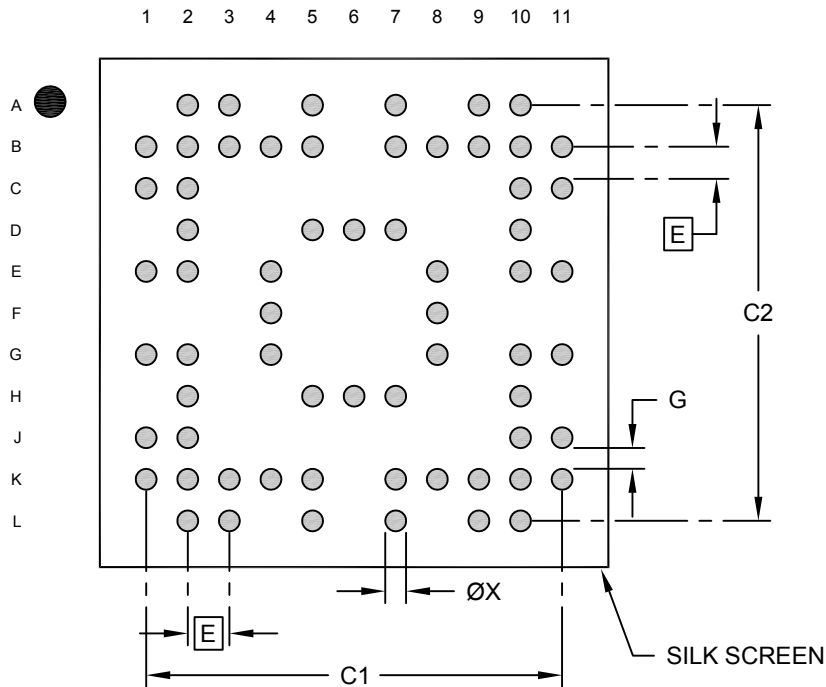

**RECOMMENDED LAND PATTERN**

Dimension Limits	Units	MILLIMETERS		
		MIN	NOM	MAX
Contact Pitch	E	0.50 BSC		
Overall Contact Pad Spacing	C1		5.00	
Overall Contact Pad Spacing	C2		5.00	
Contact Pad Width (X64)	X1			0.20
Contact Pad to Contact Pad	G	0.25		

**Notes:**

1. Dimensioning and tolerancing per ASME Y14.5M  
BSC: Basic Dimension. Theoretically exact value shown without tolerances.

**Package Outlines and Dimensions**

**84-Ball Very, Very Thin Fine Pitch Ball Grid Array (SX) - 7x7 mm Body [WFBGA]**

**Note:** For the most current package drawings, please see the Microchip Packaging Specification located at <http://www.microchip.com/packaging>

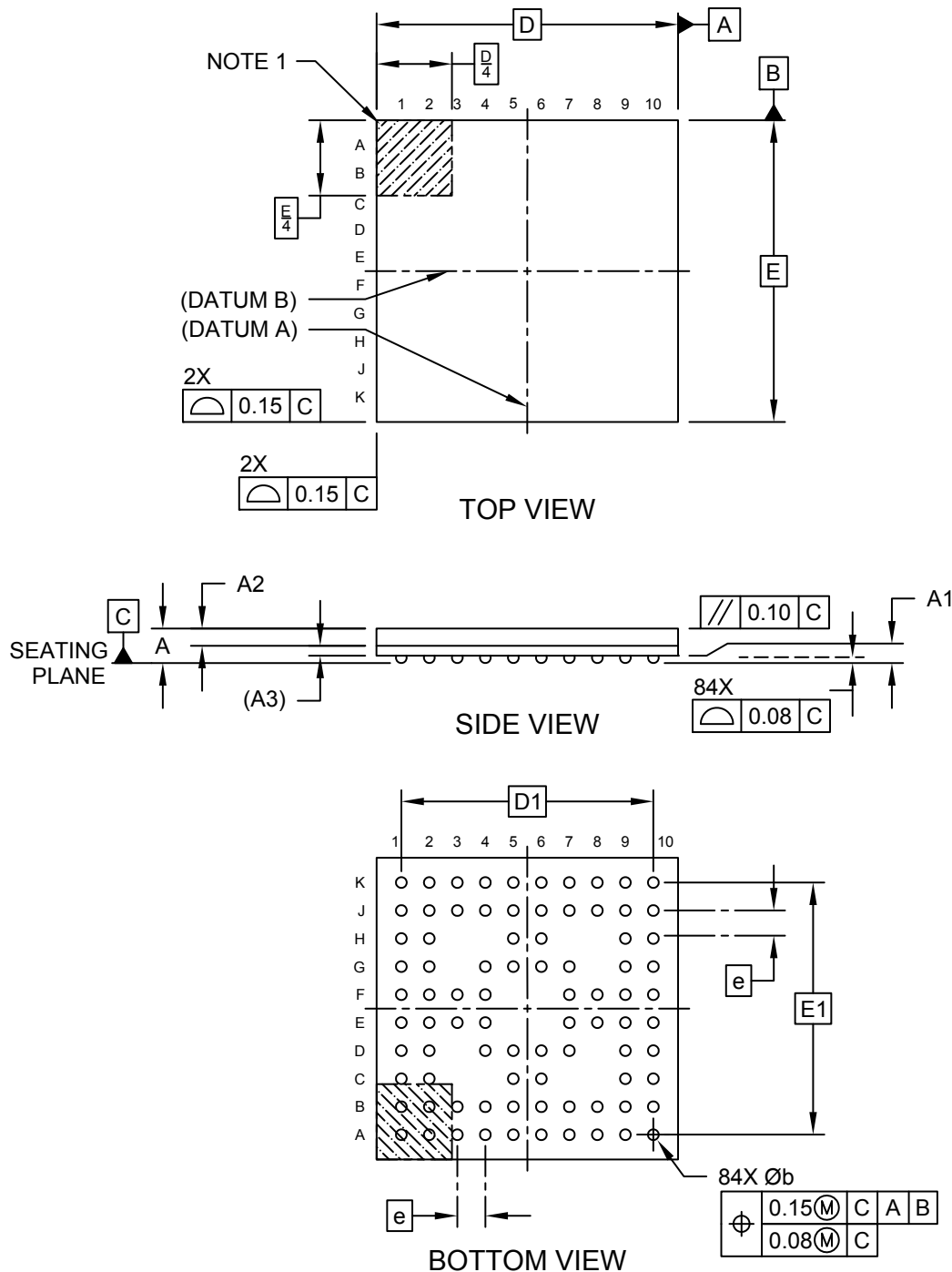

---



---

**Package Outlines and Dimensions**

---



---

**84-Ball Very, Very Thin Fine Pitch Ball Grid Array (SX) - 7x7 mm Body [WFBGA]**

**Note:** For the most current package drawings, please see the Microchip Packaging Specification located at <http://www.microchip.com/packaging>

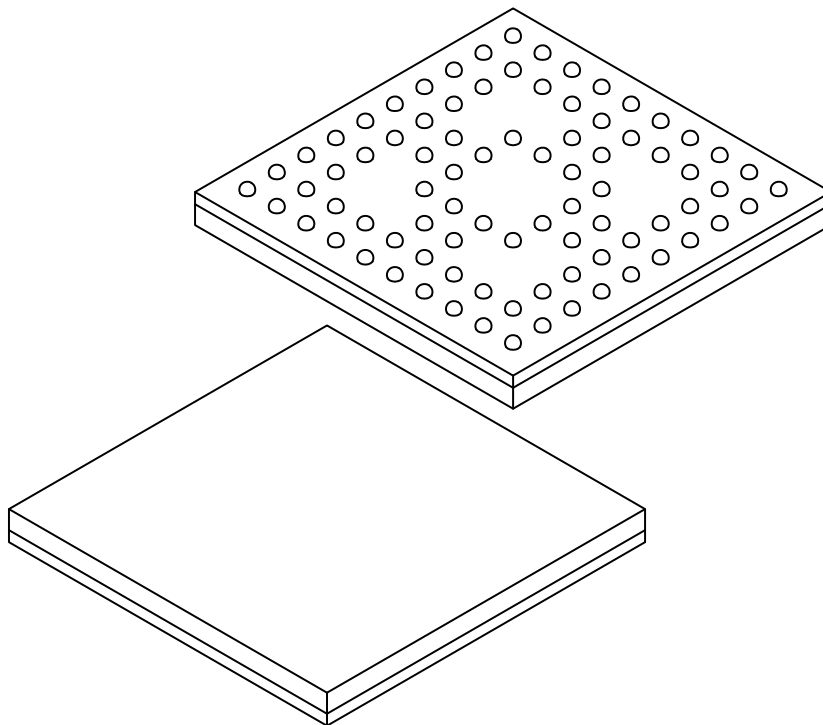

		Units	MILLIMETERS		
Dimension Limits			MIN	NOM	MAX
Number of Terminals	N		84		
Pitch	e		0.65 BSC		
Overall Height	A	-	-	0.80	
Standoff	A1	0.12	0.17		-
Mold Thickness	A2	0.35	0.40		0.45
Substrate Thickness	A3	0.26 REF			
Overall Length	D	7.00 BSC			
Overall Terminal Spacing	D1	5.85 BSC			
Overall Width	E	7.00 BSC			
Overall Terminal Spacing	E1	5.85 BSC			
Terminal Diameter	b	0.20	0.25	0.30	

**Notes:**

1. Pin 1 visual index feature may vary, but must be located within the hatched area.
2. Dimensioning and tolerancing per ASME Y14.5M

BSC: Basic Dimension. Theoretically exact value shown without tolerances.

REF: Reference Dimension, usually without tolerance, for information purposes only.



## Footprint Outlines and Dimensions

### 84-Ball Very, Very Thin Fine Pitch Ball Grid Array (SX) - 7x7 mm Body [WFBGA]

**Note:** For the most current package drawings, please see the Microchip Packaging Specification located at <http://www.microchip.com/packaging>

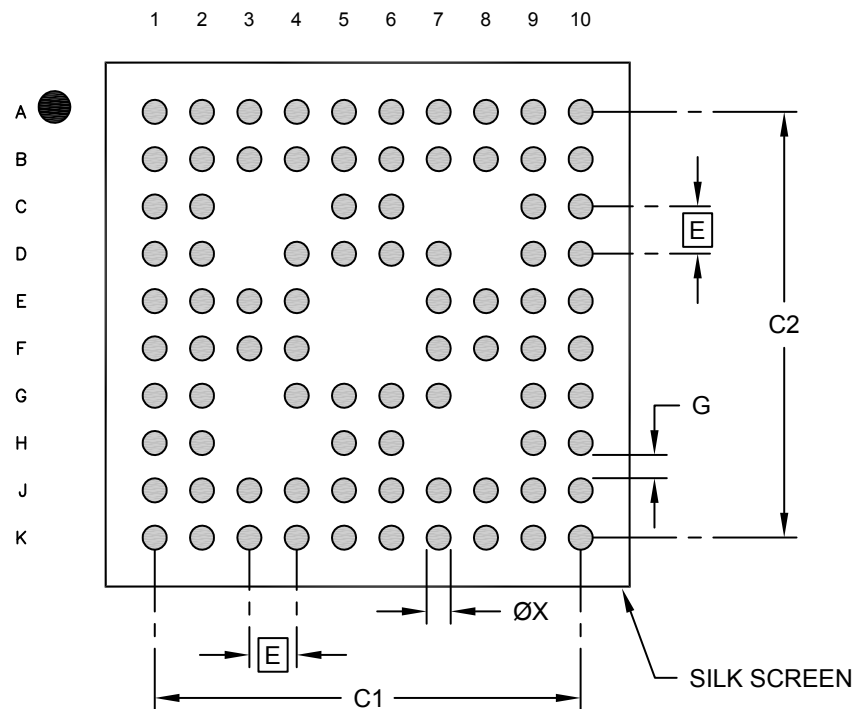

RECOMMENDED LAND PATTERN

	Units	MILLIMETERS		
		MIN	NOM	MAX
Dimension Limits				
Contact Pitch	E	0.65 BSC		
Overall Contact Pad Spacing	C1		5.85	
Overall Contact Pad Spacing	C2		5.85	
Contact Pad Width (X84)	X1			0.33
Contact Pad to Contact Pad	G	0.25		

**Notes:**

1. Dimensioning and tolerancing per ASME Y14.5M  
BSC: Basic Dimension. Theoretically exact value shown without tolerances.

**Package Outlines and Dimensions**

**100-Ball Very, Very Thin Fine Pitch Ball Grid Array (SY) - 8x8 mm Body [WFBGA]**

**Note:** For the most current package drawings, please see the Microchip Packaging Specification located at <http://www.microchip.com/packaging>

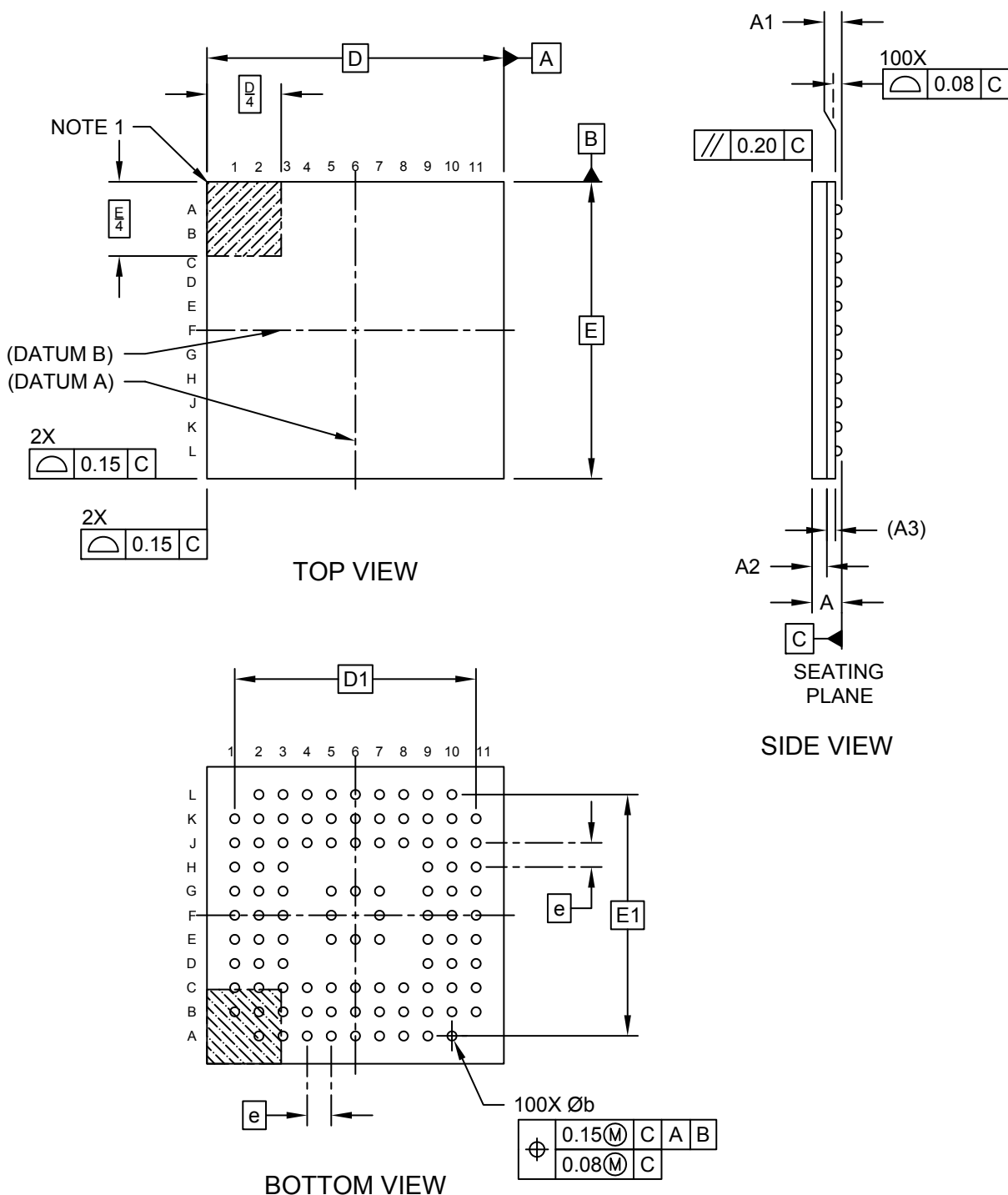

## Package Outlines and Dimensions

### 100-Ball Very, Very Thin Fine Pitch Ball Grid Array (SY) - 8x8 mm Body [WFBGA]

**Note:** For the most current package drawings, please see the Microchip Packaging Specification located at <http://www.microchip.com/packaging>

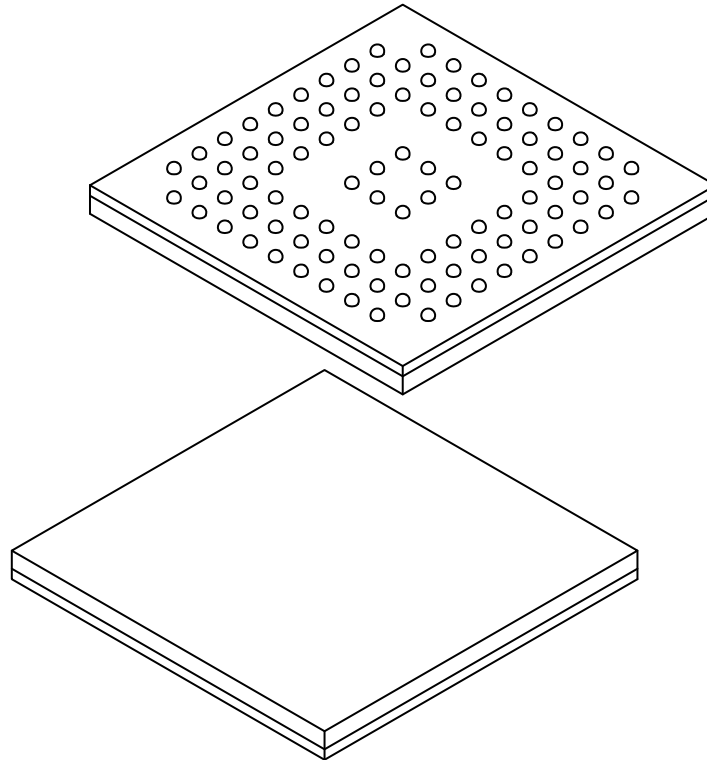

		Units	MILLIMETERS		
Dimension Limits			MIN	NOM	MAX
Number of Terminals	N		100		
Pitch	e		0.65 BSC		
Overall Height	A		-	-	0.80
Standoff	A1		0.12	0.17	-
Mold Thickness	A2		0.35	0.40	0.45
Substrate Thickness	A3		0.26 REF		
Overall Length	D		8.00 BSC		
Overall Terminal Spacing	D1		6.50 BSC		
Overall Width	E		8.00 BSC		
Overall Terminal Spacing	E1		6.50 BSC		
Terminal Diameter	b		0.20	0.25	0.30

**Notes:**

1. Pin 1 visual index feature may vary, but must be located within the hatched area.
2. Dimensioning and tolerancing per ASME Y14.5M

BSC: Basic Dimension. Theoretically exact value shown without tolerances.

REF: Reference Dimension, usually without tolerance, for information purposes only.

**Footprint Outlines and Dimensions**

**100-Ball Very, Very Thin Fine Pitch Ball Grid Array (SY) - 8x8 mm Body [WFBGA]**

**Note:** For the most current package drawings, please see the Microchip Packaging Specification located at <http://www.microchip.com/packaging>

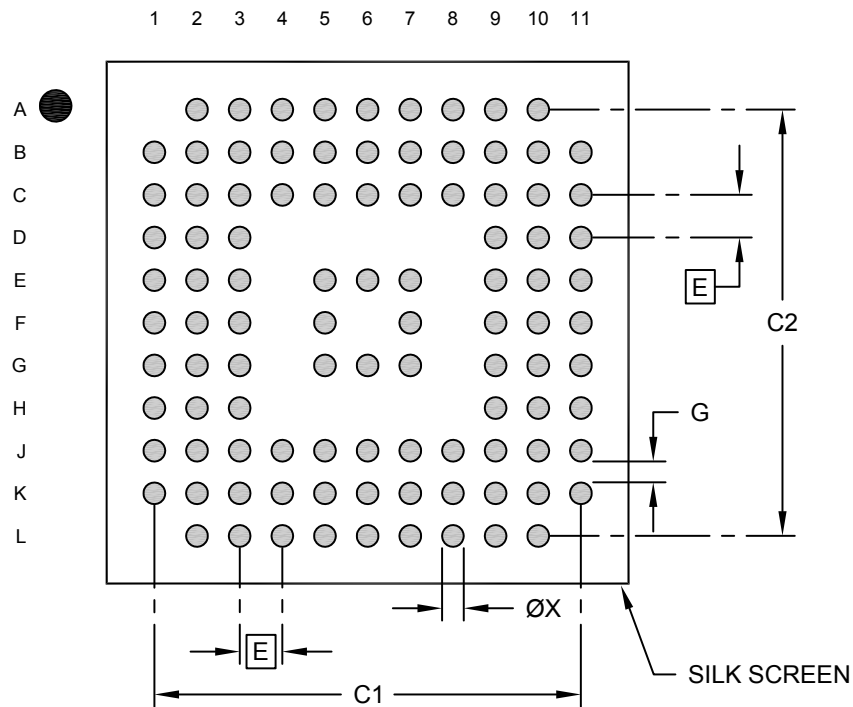

**RECOMMENDED LAND PATTERN**

Units		MILLIMETERS		
Dimension Limits		MIN	NOM	MAX
Contact Pitch	E	0.65 BSC		
Overall Contact Pad Spacing	C1		6.50	
Overall Contact Pad Spacing	C2		6.50	
Contact Pad Width (X100)	X1			0.33
Contact Pad to Contact Pad	G	0.25		

**Notes:**

1. Dimensioning and tolerancing per ASME Y14.5M  
BSC: Basic Dimension. Theoretically exact value shown without tolerances.

**Package Outlines and Dimensions**

**144-Ball Very, Very Thin Fine Pitch Ball Grid Array (SZ) -9x9x0.8 mm Body [WFBGA]**

**Note:** For the most current package drawings, please see the Microchip Packaging Specification located at <http://www.microchip.com/packaging>

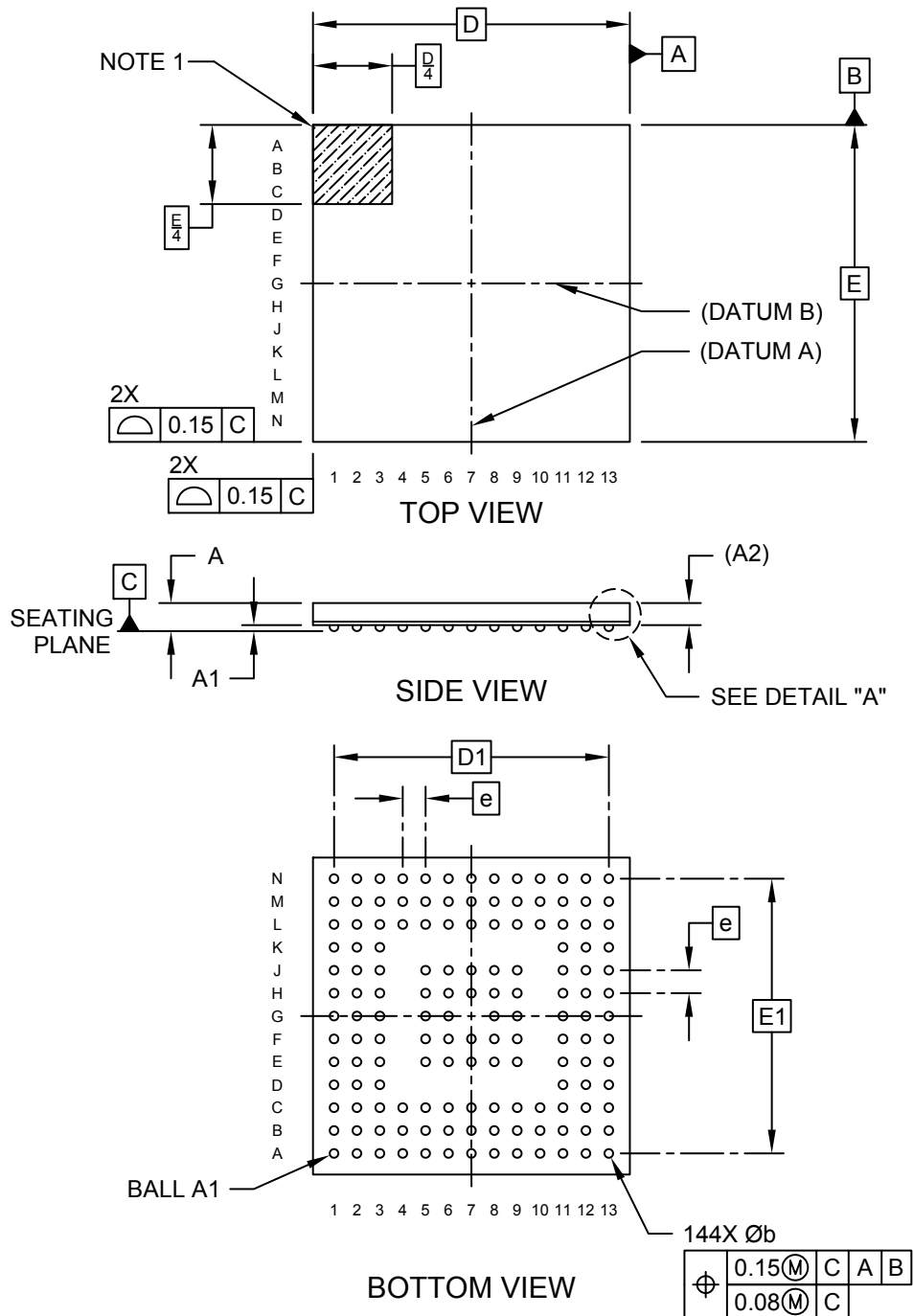

**Package Outlines and Dimensions**

**144-Ball Very, Very Thin Fine Pitch Ball Grid Array (SZ) -9x9x0.8 mm Body [WFBGA]**

**Note:** For the most current package drawings, please see the Microchip Packaging Specification located at <http://www.microchip.com/packaging>

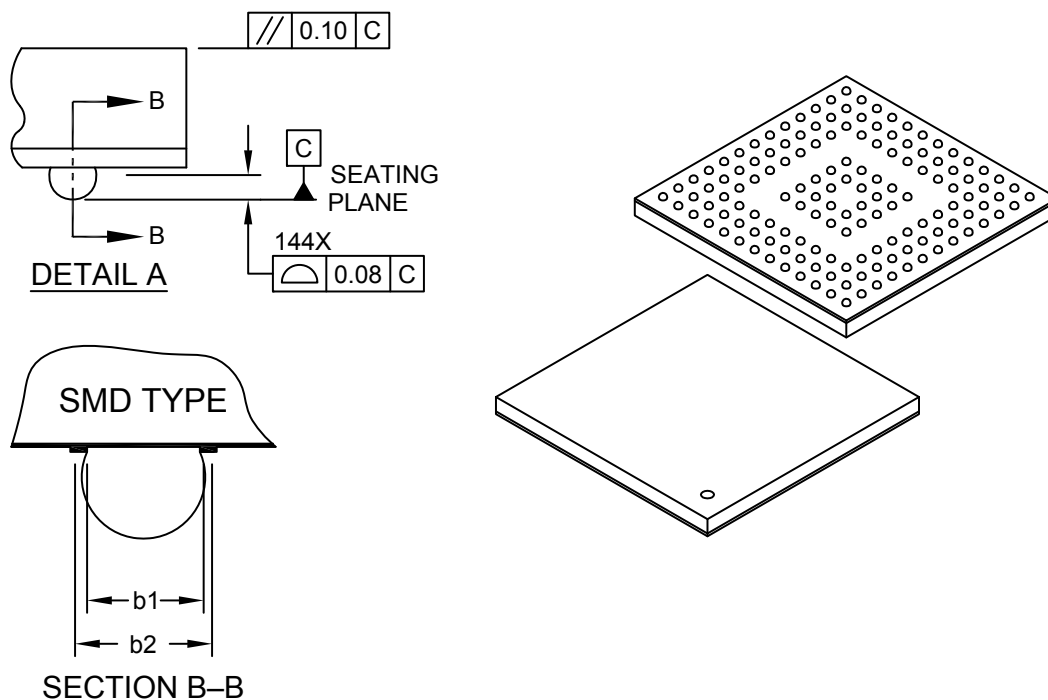

Dimension Limits	Units	MILLIMETERS		
		MIN	NOM	MAX
Ball Pitch	e	0.65 BSC		
Overall Height	A	-	0.70	0.80
Standoff	A1	0.12	0.17	0.22
Terminal Thickness	A2	0.53 REF		
Overall Length	D	9.00 BSC		
Overall Ball Pitch	D1	7.80 BSC		
Overall Width	E	9.00 BSC		
Overall Ball Pitch	E1	7.80 BSC		
Ball Diameter	b	0.20	0.25	0.30
Finished Solder Mask Opening	b1	0.22	0.25	0.28
Finished Bottom Ball Pad	b2	0.30	0.35	0.40

**Notes:**

- Ball A1 visual index feature may vary, but must be located within the hatched area.
- Package is saw singulated
- Dimensioning and tolerancing per ASME Y14.5M  
 BSC: Basic Dimension. Theoretically exact value shown without tolerances.  
 REF: Reference Dimension, usually without tolerance, for information purposes only.
- Primary Datum "C" and Seating Plane are defined by the spherical crowns of the contact solder balls.
- Dimension "A" does not include attached external features, such as heat sink or chip capacitors.
- The package ball solderable surface is solder-mask defined (SMD) type.

---



---

## Footprint Outlines and Dimensions

---



---

### 144-Ball Very, Very Thin Fine Pitch Ball Grid Array (SZ) -9x9x0.8 mm Body [WFBGA]

**Note:** For the most current package drawings, please see the Microchip Packaging Specification located at <http://www.microchip.com/packaging>

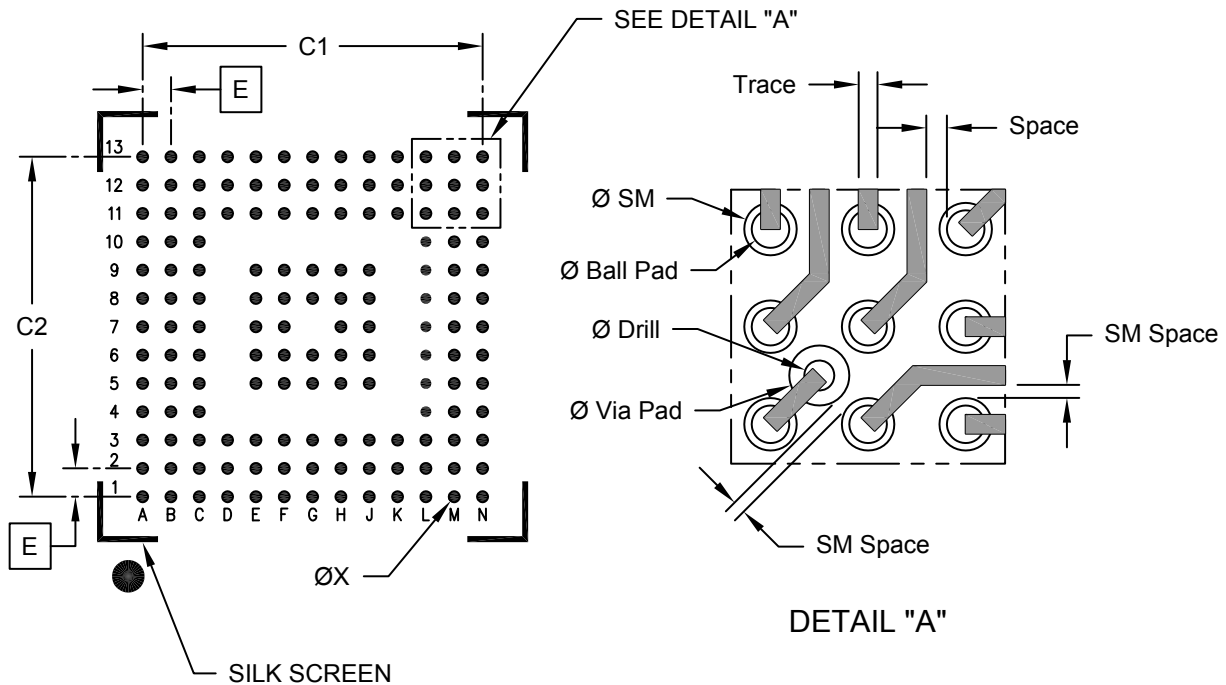

#### RECOMMENDED LAND PATTERN

		MILLIMETERS		
Units		MIN	NOM	MAX
Dimension Limits				
Contact Pitch	E	0.65 BSC		
Overall Contact Pitch	C1		7.80	
Overall Contact Pitch	C2		7.80	
Contact Pad Diameter	X		0.25	

#### Routing Dimensions

Units	mm
Feature	
Ø PAD	0.250
Ø SM	0.350
Trace Width	0.125
Space (Min.)	0.135
SM Space (Min.)	0.085
Ø Via Pad	0.400
Ø Drill	0.200

**Notes:**

1. Dimensioning and tolerancing per ASME Y14.5M  
BSC: Basic Dimension. Theoretically exact value shown without tolerances.

**Package Outlines and Dimensions**

**169-Ball Very, Very Thin Fine Pitch Ball Grid Array (TN) - 11x11 mm Body [WFBGA]**

**Note:** For the most current package drawings, please see the Microchip Packaging Specification located at <http://www.microchip.com/packaging>

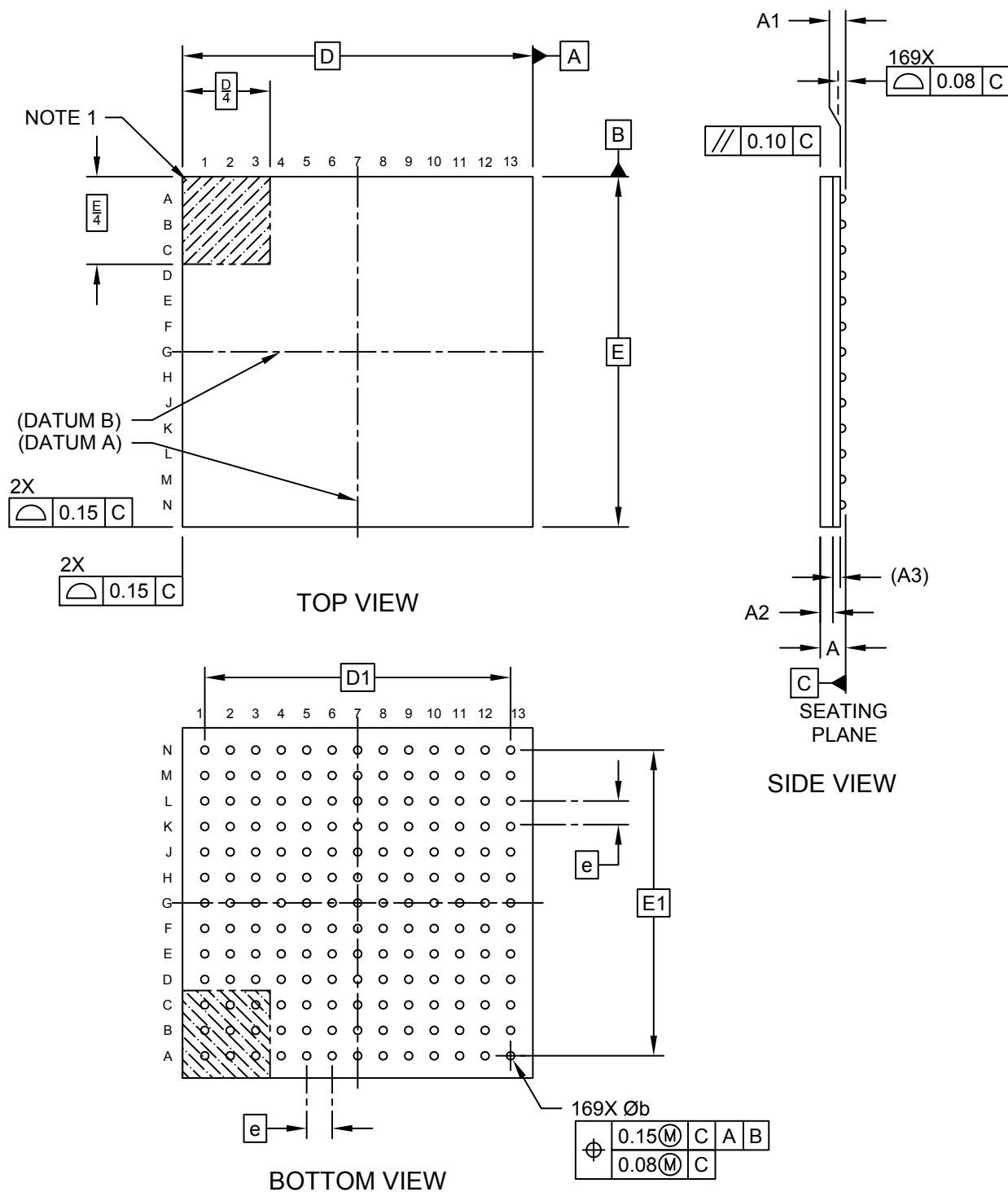

Microchip Technology Drawing C04-336A Sheet 1 of 2



---



---

## Package Outlines and Dimensions

---



---

### 169-Ball Very, Very Thin Fine Pitch Ball Grid Array (TN) - 11x11 mm Body [WFBGA]

**Note:** For the most current package drawings, please see the Microchip Packaging Specification located at <http://www.microchip.com/packaging>

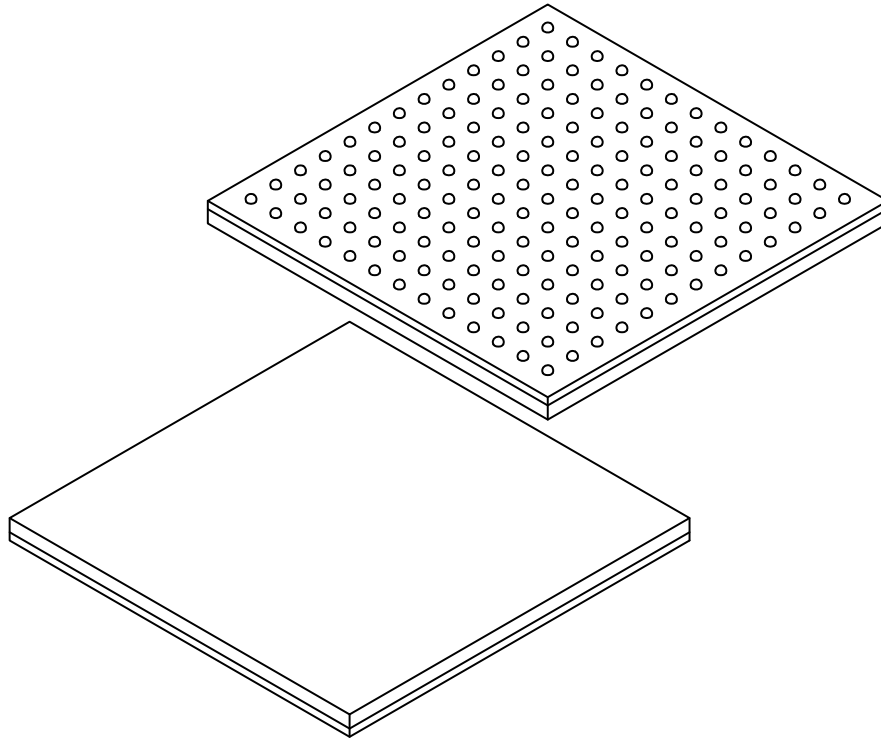

		Units	MILLIMETERS		
Dimension Limits			MIN	NOM	MAX
Number of Terminals	N		169		
Pitch	e		0.80 BSC		
Overall Height	A	-	-	0.80	
Standoff	A1	0.12	0.17	-	
Mold Thickness	A2	0.35	0.40	0.45	
Substrate Thickness	A3	0.26 REF			
Overall Length	D	11.00 BSC			
Overall Terminal Spacing	D1	9.60 BSC			
Overall Width	E	11.00 BSC			
Overall Terminal Spacing	E1	9.60 BSC			
Terminal Diameter	b	0.20	0.25	0.30	

**Notes:**

1. Pin 1 visual index feature may vary, but must be located within the hatched area.
2. Dimensioning and tolerancing per ASME Y14.5M

BSC: Basic Dimension. Theoretically exact value shown without tolerances.

REF: Reference Dimension, usually without tolerance, for information purposes only.

**Footprint Outlines and Dimensions**

**169-Ball Very, Very Thin Fine Pitch Ball Grid Array (TN) - 11x11 mm Body [WFBGA]**

**Note:** For the most current package drawings, please see the Microchip Packaging Specification located at <http://www.microchip.com/packaging>

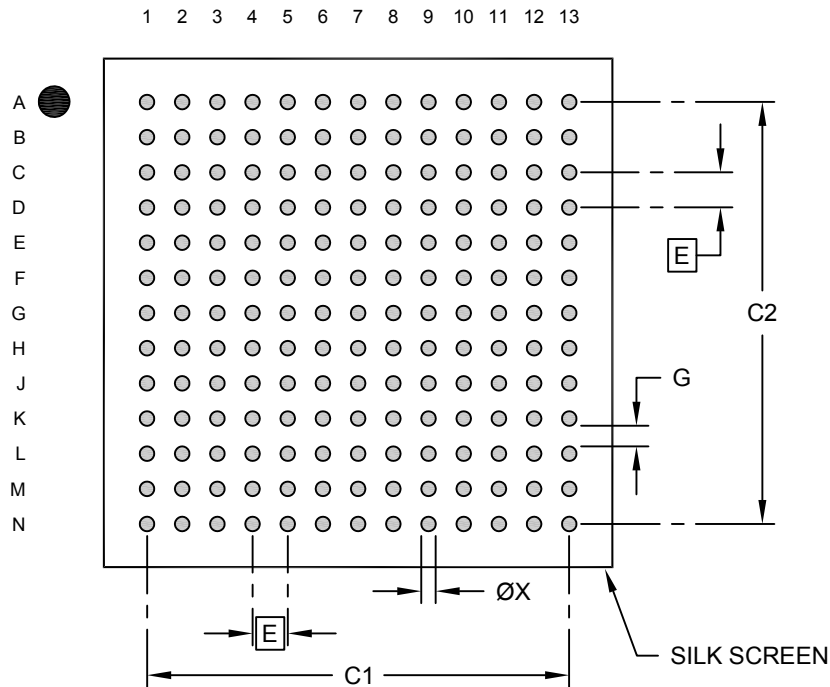

**RECOMMENDED LAND PATTERN**

Dimension Limits	Units	MILLIMETERS		
		MIN	NOM	MAX
Contact Pitch	E	0.80 BSC		
Overall Contact Pad Spacing	C1		9.60	
Overall Contact Pad Spacing	C2		9.60	
Contact Pad Width (X169)	X1			0.33
Contact Pad to Contact Pad	G	0.25		

**Notes:**

1. Dimensioning and tolerancing per ASME Y14.5M  
BSC: Basic Dimension. Theoretically exact value shown without tolerances.

---

---

**Package Outlines and Dimensions**

---

---

**XFBGA**

**Package Outlines and Dimensions**

**144-Ball Extremely Thin Fine Pitch Ball Grid Array (TZ) - 7x7 mm Body [XFBGA]**

**Note:** For the most current package drawings, please see the Microchip Packaging Specification located at <http://www.microchip.com/packaging>

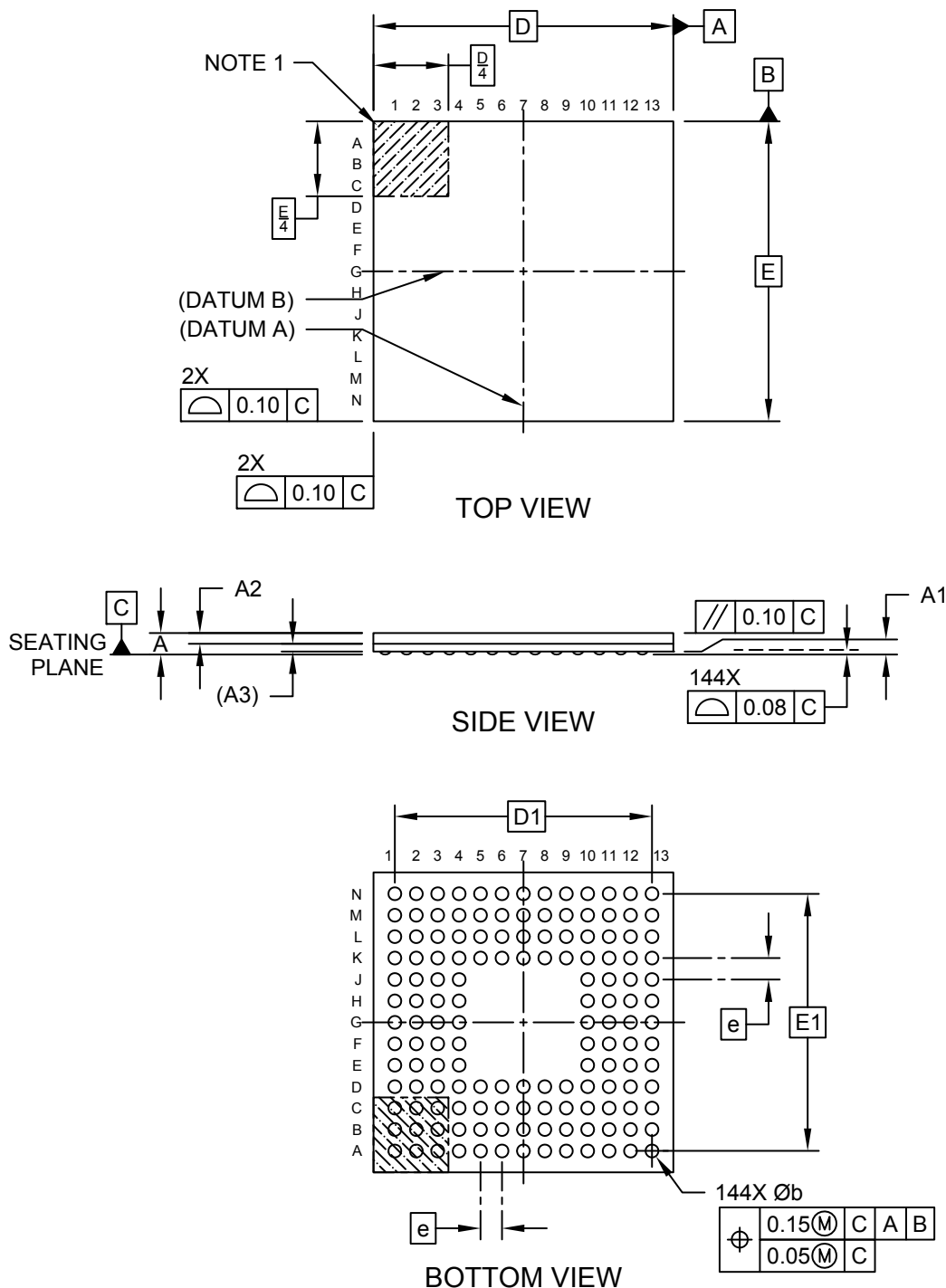

---



---

## Package Outlines and Dimensions

---



---

### 144-Ball Extremely Thin Fine Pitch Ball Grid Array (TZ) - 7x7 mm Body [XFBGA]

**Note:** For the most current package drawings, please see the Microchip Packaging Specification located at <http://www.microchip.com/packaging>

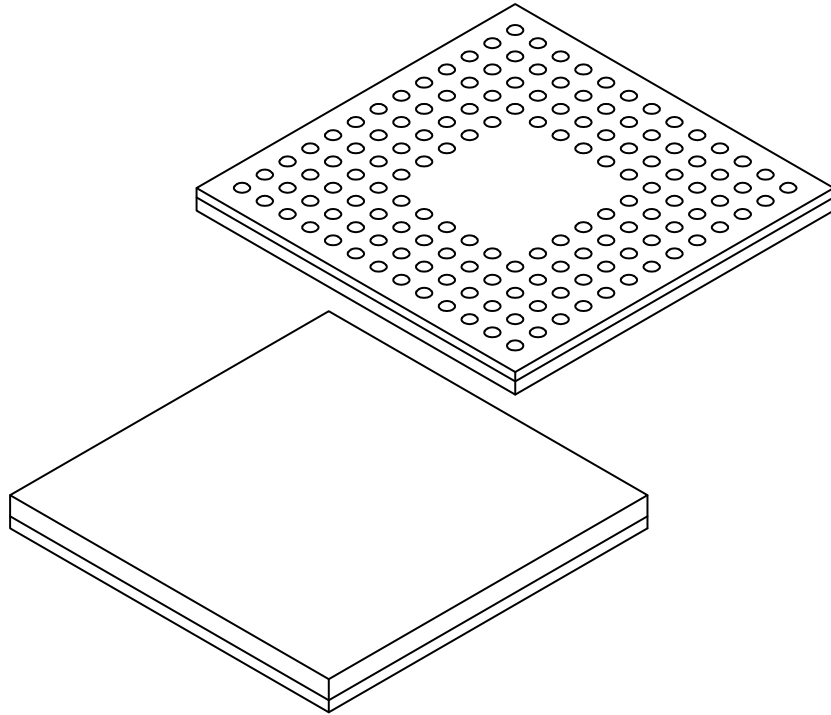

		Units	MILLIMETERS		
Dimension Limits			MIN	NOM	MAX
Number of Terminals	N		144		
Pitch	e		0.50 BSC		
Overall Height	A	-	-	-	0.50
Standoff	A1	0.045	0.070		0.095
Mold Thickness	A2	0.22	0.25		0.28
Substrate Thickness	A3		0.18 REF		
Overall Length	D		7.00 BSC		
Overall Terminal Spacing	D1		6.00 BSC		
Overall Width	E		7.00 BSC		
Overall Terminal Spacing	E1		6.00 BSC		
Terminal Diameter	b	0.25	0.30		0.35

**Notes:**

1. Pin 1 visual index feature may vary, but must be located within the hatched area.
2. Dimensioning and tolerancing per ASME Y14.5M

BSC: Basic Dimension. Theoretically exact value shown without tolerances.

REF: Reference Dimension, usually without tolerance, for information purposes only.

**Footprint Outlines and Dimensions**

**144-Ball Extremely Thin Fine Pitch Ball Grid Array (TZ) - 7x7 mm Body [XFBGA]**

**Note:** For the most current package drawings, please see the Microchip Packaging Specification located at <http://www.microchip.com/packaging>

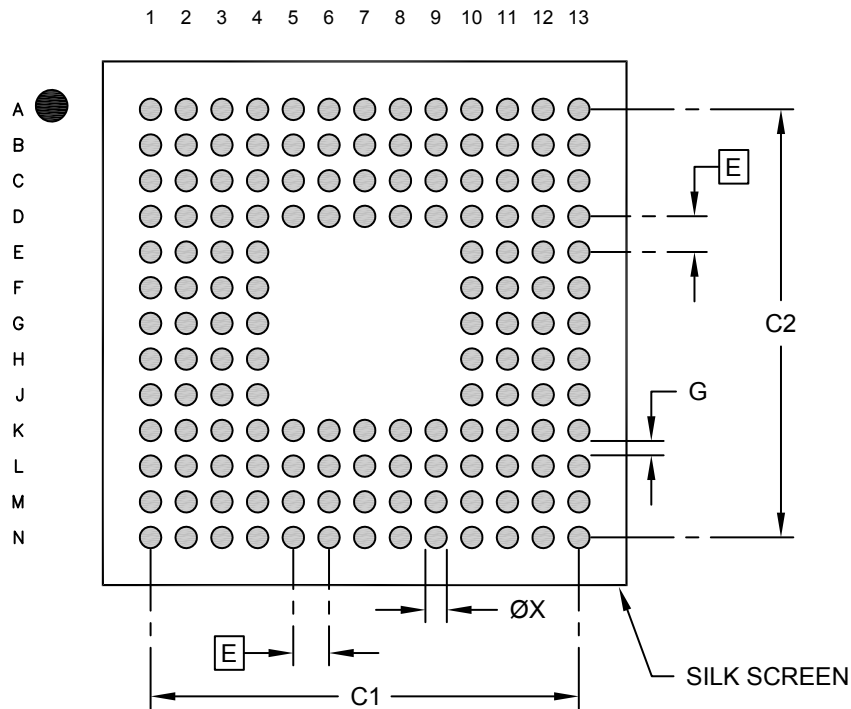

**RECOMMENDED LAND PATTERN**

Dimension Limits	Units	MILLIMETERS		
		MIN	NOM	MAX
Contact Pitch	E	0.50 BSC		
Overall Contact Pad Spacing	C1		6.00	
Overall Contact Pad Spacing	C2		6.00	
Contact Pad Width (X144)	X1			0.30
Contact Pad to Contact Pad	G	0.25		

**Notes:**

1. Dimensioning and tolerancing per ASME Y14.5M  
BSC: Basic Dimension. Theoretically exact value shown without tolerances.

---

---

**Package Outlines and Dimensions**

---

---

**VFLGA**

**Package Outlines and Dimensions**

**4-Lead Very Thin Fine Pitch Land Grid Array (ARA) - 1.6x1.2 mm Body [VFLGA]**

**Note:** For the most current package drawings, please see the Microchip Packaging Specification located at <http://www.microchip.com/packaging>

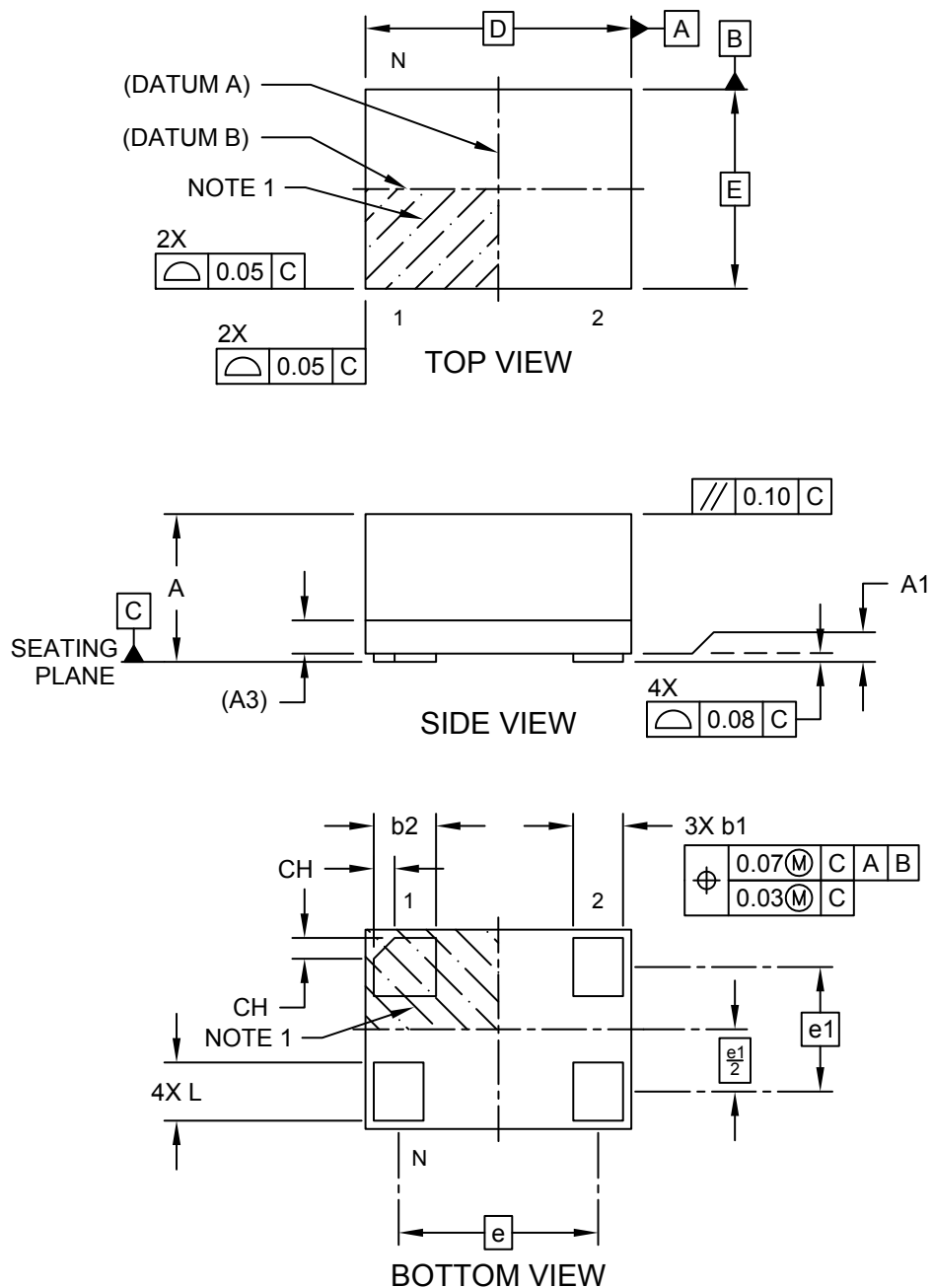



---



---

## Package Outlines and Dimensions

---



---

### 4-Lead Very Thin Fine Pitch Land Grid Array (ARA) - 1.6x1.2 mm Body [VFLGA]

**Note:** For the most current package drawings, please see the Microchip Packaging Specification located at <http://www.microchip.com/packaging>

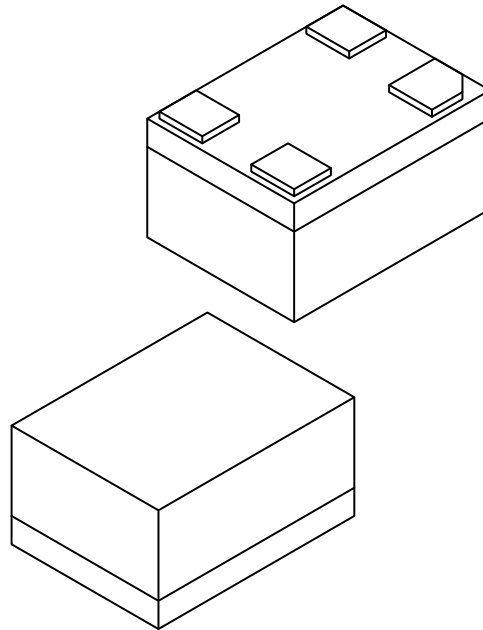

Dimension Limits	Units	MILLIMETERS		
		MIN	NOM	MAX
Number of Terminals	N	4		
Terminal Pitch	e	1.20 BSC		
Terminal Pitch	e1	0.75 BSC		
Overall Height	A	0.79	0.84	0.89
Standoff	A1	0.00	0.02	0.05
Substrate Thickness (with Terminals)	A3	0.20 REF		
Overall Length	D	1.60 BSC		
Overall Width	E	1.20 BSC		
Terminal Width	b1	0.25	0.30	0.35
Terminal Width	b2	0.325	0.375	0.425
Terminal Length	L	0.30	0.35	0.40
Terminal 1 Index Chamfer	CH	-	0.125	-

**Notes:**

1. Pin 1 visual index feature may vary, but must be located within the hatched area.
2. Package is saw singulated
3. Dimensioning and tolerancing per ASME Y14.5M

BSC: Basic Dimension. Theoretically exact value shown without tolerances.

REF: Reference Dimension, usually without tolerance, for information purposes only.

**Footprint Outlines and Dimensions**

**4-Lead Very Thin Fine Pitch Land Grid Array (ARA) - 1.6x1.2 mm Body [VFLGA]**

**Note:** For the most current package drawings, please see the Microchip Packaging Specification located at <http://www.microchip.com/packaging>

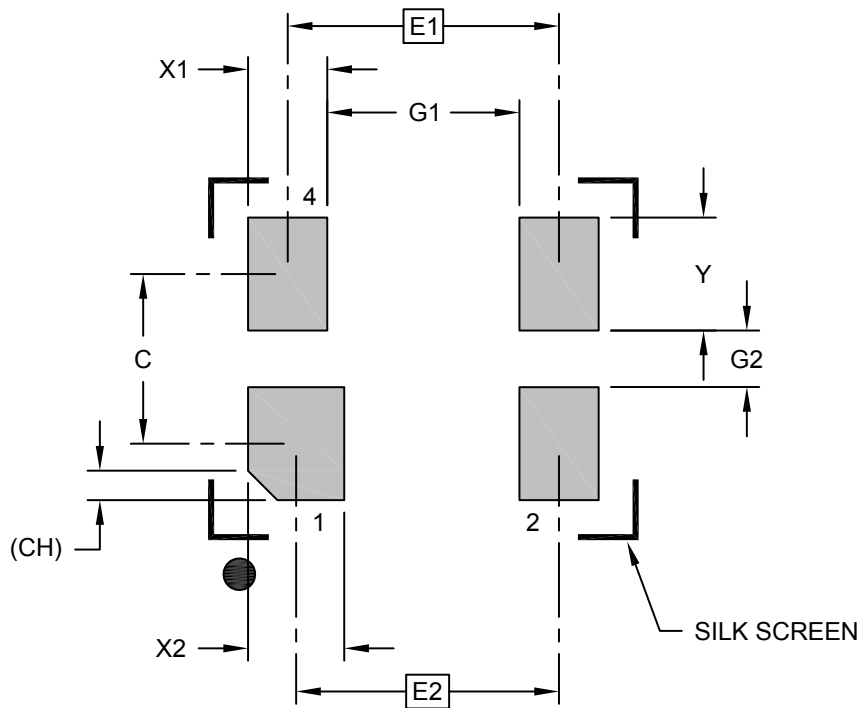

**RECOMMENDED LAND PATTERN**

Dimension Limits	Units	MILLIMETERS		
		MIN	NOM	MAX
Contact Pitch	E1		1.20 BSC	
Contact Pitch	E2		1.16 BSC	
Contact Spacing	C		0.75	
Contact Width (X3)	X1			0.35
Contact Width	X2			0.43
Contact Pad Length (X6)	Y			0.50
Space Between Contacts (X4)	G1	0.85		
Space Between Contacts (X3)	G2	0.25		
Contact 1 Index Chamfer	CH	0.13 X 45° REF		

**Notes:**

1. Dimensioning and tolerancing per ASME Y14.5M  
BSC: Basic Dimension. Theoretically exact value shown without tolerances.

**Package Outlines and Dimensions**

**4-Lead Very Thin Fine Pitch Land Grid Array (ASA) - 2.0x1.6 mm Body [VFLGA]**

**Note:** For the most current package drawings, please see the Microchip Packaging Specification located at <http://www.microchip.com/packaging>

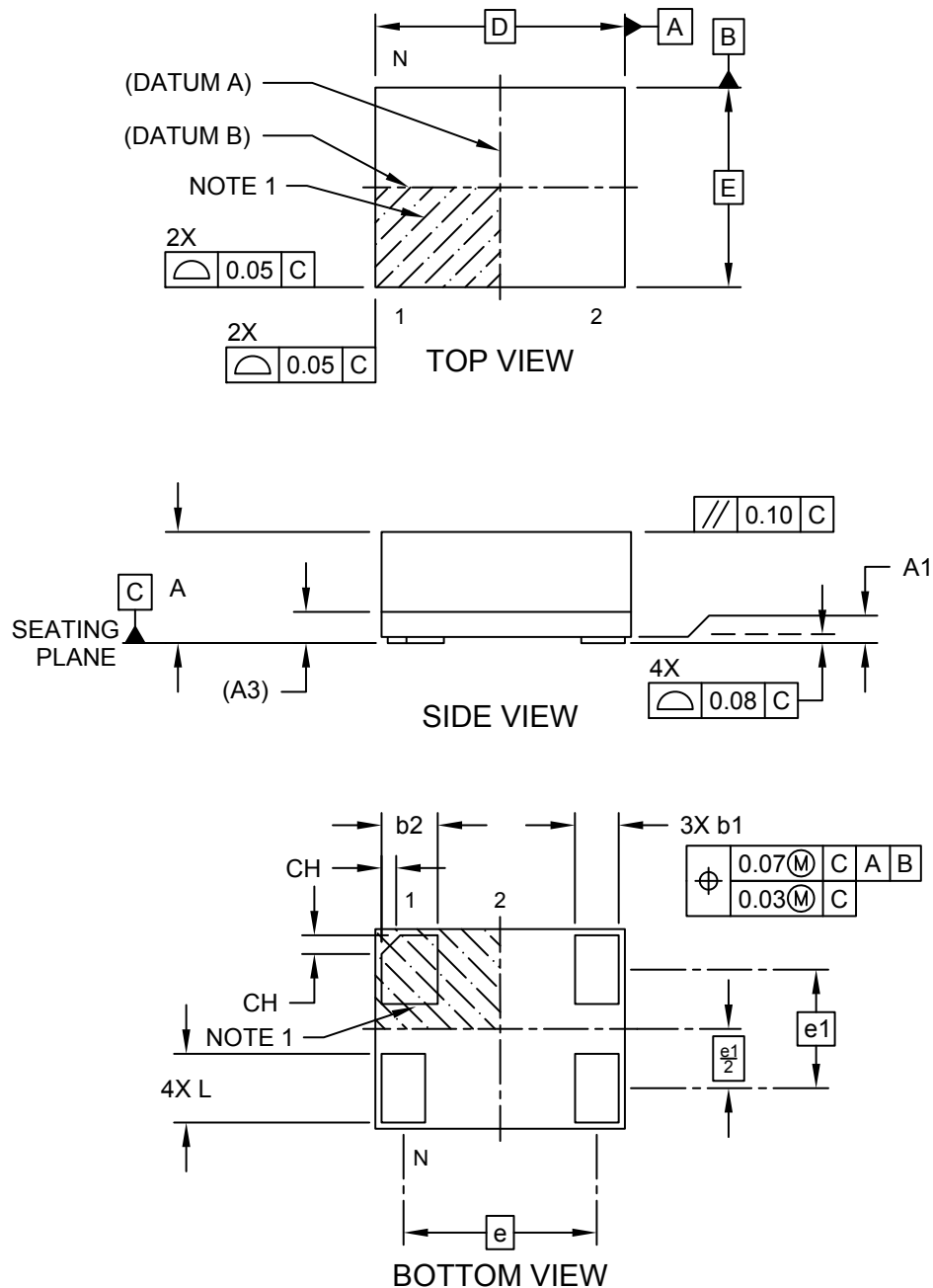

**Package Outlines and Dimensions**

**4-Lead Very Thin Fine Pitch Land Grid Array (ASA) - 2.0x1.6 mm Body [VFLGA]**

**Note:** For the most current package drawings, please see the Microchip Packaging Specification located at <http://www.microchip.com/packaging>

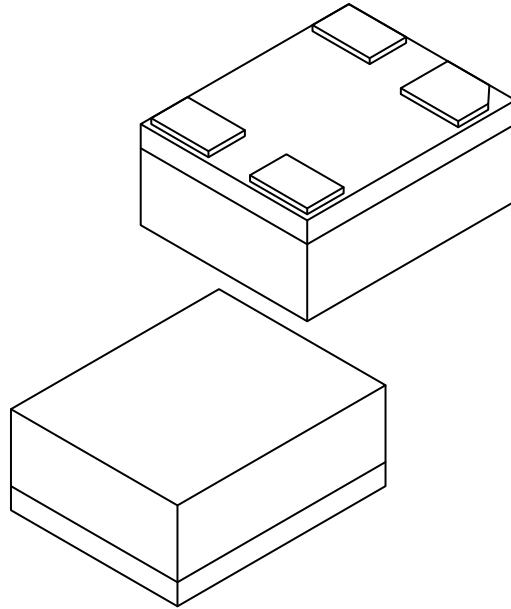

Dimension Limits	Units	MILLIMETERS		
		MIN	NOM	MAX
Number of Terminals	N	6		
Terminal Pitch	e	1.55 BSC		
Terminal Pitch	e1	0.95 BSC		
Overall Height	A	0.79	0.84	0.89
Standoff	A1	0.00	0.02	0.05
Substrate Thickness (with Terminals)	A3	0.20 REF		
Overall Length	D	2.00 BSC		
Overall Width	E	1.60 BSC		
Terminal Width	b1	0.30	0.35	0.40
Terminal Width	b2	0.40	0.45	0.50
Terminal Length	L	0.50	0.55	0.60
Terminal 1 Index Chamfer	CH	-	0.15	-

Notes:

1. Pin 1 visual index feature may vary, but must be located within the hatched area.
2. Package is saw singulated
3. Dimensioning and tolerancing per ASME Y14.5M

BSC: Basic Dimension. Theoretically exact value shown without tolerances.

REF: Reference Dimension, usually without tolerance, for information purposes only.

---



---

## Footprint Outlines and Dimensions

---



---

### 4-Lead Very Thin Fine Pitch Land Grid Array (ASA) - 2.0x1.6 mm Body [VFLGA]

**Note:** For the most current package drawings, please see the Microchip Packaging Specification located at <http://www.microchip.com/packaging>

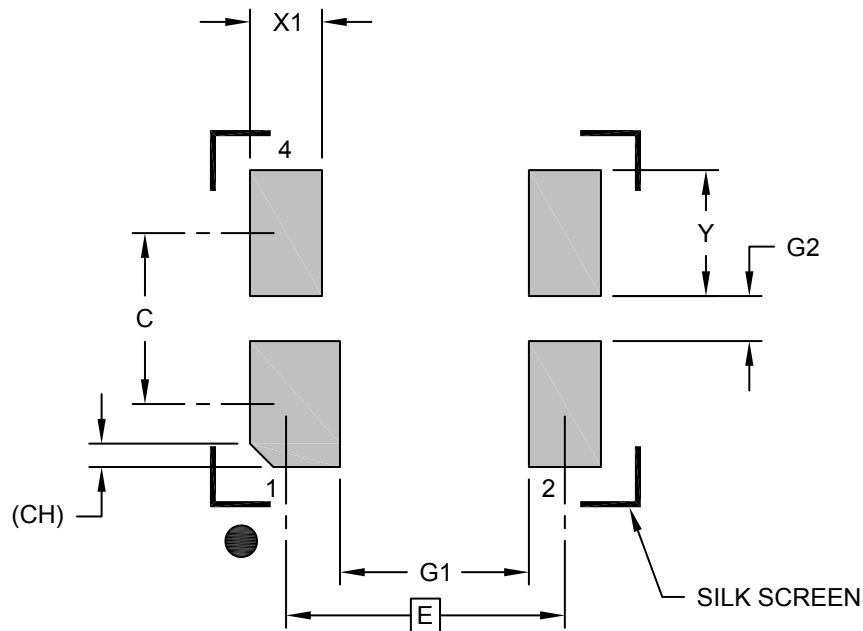

**RECOMMENDED LAND PATTERN**

Dimension Limits	Units	MILLIMETERS		
		MIN	NOM	MAX
Contact Pitch	E	1.55 BSC		
Contact Spacing	C		0.95	
Contact Width (X4)	X1			0.50
Contact Width (X2)	X2			0.40
Contact Pad Length (X6)	Y			0.70
Space Between Contacts (X4)	G1	1.05		
Space Between Contacts (X3)	G2	0.25		
Contact 1 Index Chamfer	CH	0.13 X 45° REF		

**Notes:**

- Dimensioning and tolerancing per ASME Y14.5M  
BSC: Basic Dimension. Theoretically exact value shown without tolerances.

**Package Outlines and Dimensions**

**4-Lead Very Thin Land Grid Array (AUA) - 2.5x2.0 mm Body [VLGA]**

**Note:** For the most current package drawings, please see the Microchip Packaging Specification located at <http://www.microchip.com/packaging>

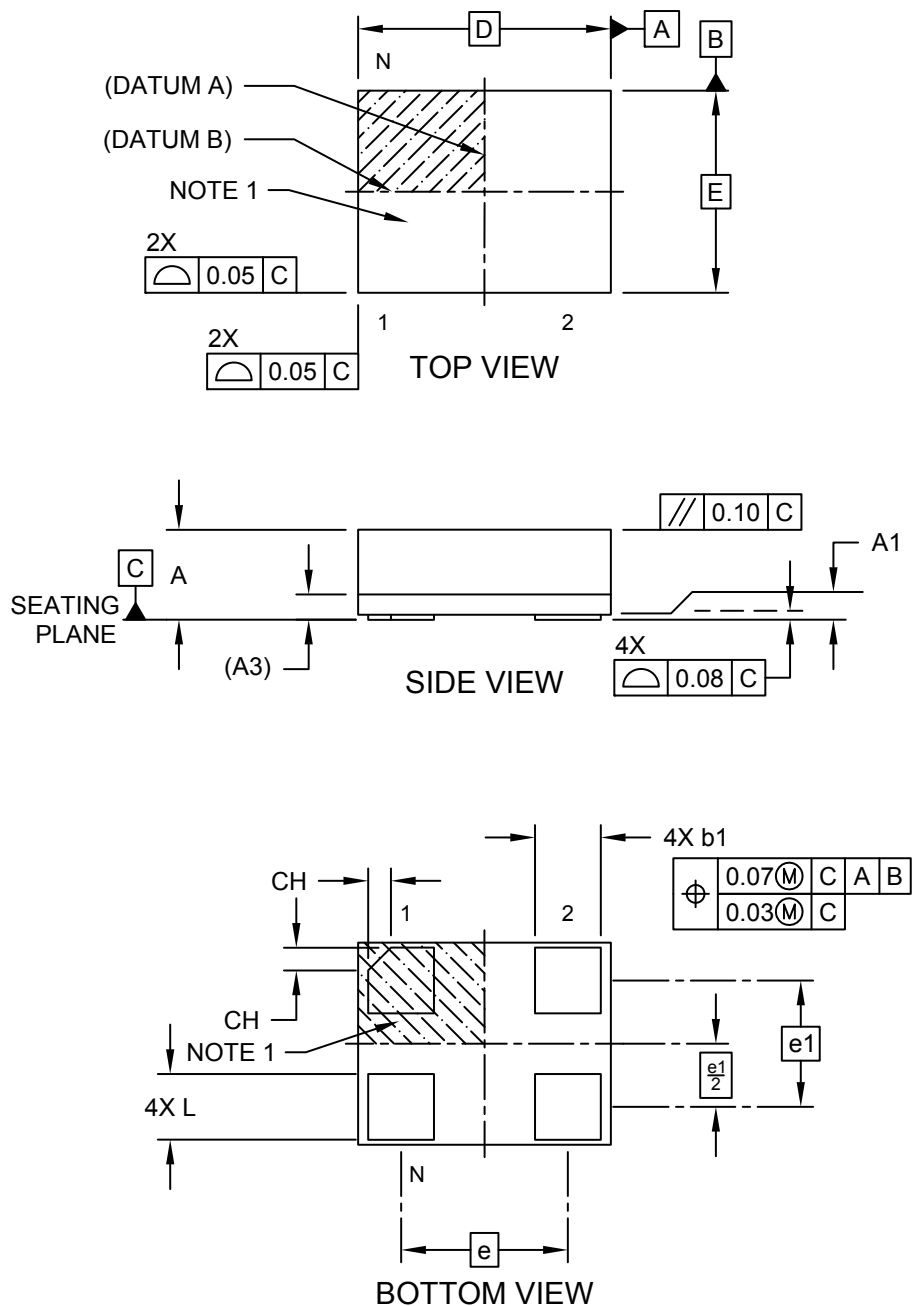

---



---

## Package Outlines and Dimensions

---



---

### 4-Lead Very Thin Land Grid Array (AUA) - 2.5x2.0 mm Body [VLGA]

**Note:** For the most current package drawings, please see the Microchip Packaging Specification located at <http://www.microchip.com/packaging>

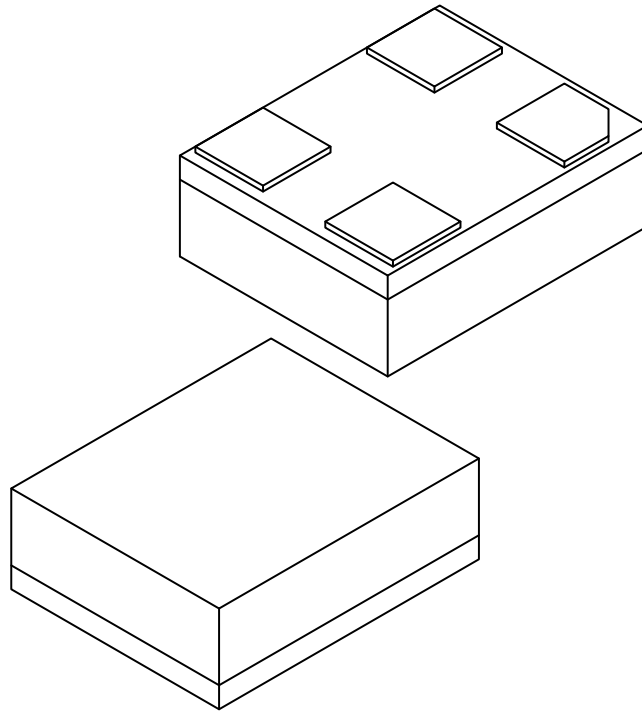

Dimension Limits	Units	MILLIMETERS		
		MIN	NOM	MAX
Number of Terminals	N	4		
Terminal Pitch	e	1.65 BSC		
Terminal Pitch	e1	1.25 BSC		
Overall Height	A	0.79	0.84	0.89
Standoff	A1	0.00	0.02	0.05
Substrate Thickness (with Terminals)	A3	0.20 REF		
Overall Length	D	2.50 BSC		
Overall Width	E	2.00 BSC		
Terminal Width	b1	0.60	0.65	0.70
Terminal Length	L	0.60	0.65	0.70
Terminal 1 Index Chamfer	CH	-	0.225	-

**Notes:**

1. Pin 1 visual index feature may vary, but must be located within the hatched area.
2. Package is saw singulated
3. Dimensioning and tolerancing per ASME Y14.5M

BSC: Basic Dimension. Theoretically exact value shown without tolerances.

REF: Reference Dimension, usually without tolerance, for information purposes only.

**Footprint Outlines and Dimensions**

**4-Lead Very Thin Land Grid Array (AUA) - 2.5x2.0 mm Body [VLGA]**

**Note:** For the most current package drawings, please see the Microchip Packaging Specification located at <http://www.microchip.com/packaging>

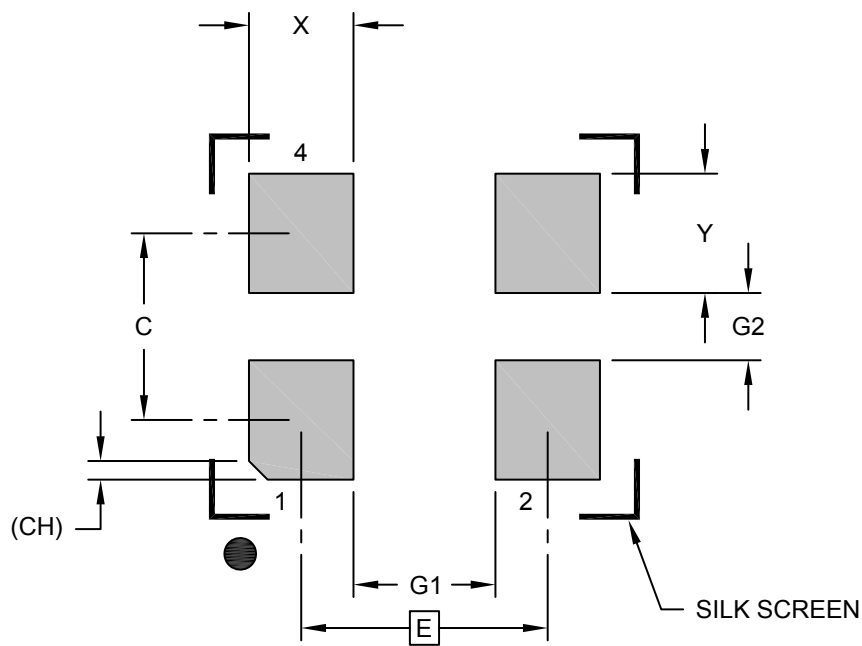

**RECOMMENDED LAND PATTERN**

Dimension Limits	Units	MILLIMETERS		
		MIN	NOM	MAX
Contact Pitch	E	1.65 BSC		
Contact Spacing	C		1.25	
Contact Width (X4)	X			0.70
Contact Pad Length (X6)	Y			0.80
Space Between Contacts (X4)	G1	0.95		
Space Between Contacts (X3)	G2	0.45		
Contact 1 Index Chamfer	CH	0.13 X 45° REF		

**Notes:**

1. Dimensioning and tolerancing per ASME Y14.5M  
BSC: Basic Dimension. Theoretically exact value shown without tolerances.



**Package Outlines and Dimensions**

**6-Lead Very Thin Fine Pitch Land Grid Array (AVA) - 1.6x1.2 mm Body [VFLGA]**

**Note:** For the most current package drawings, please see the Microchip Packaging Specification located at <http://www.microchip.com/packaging>

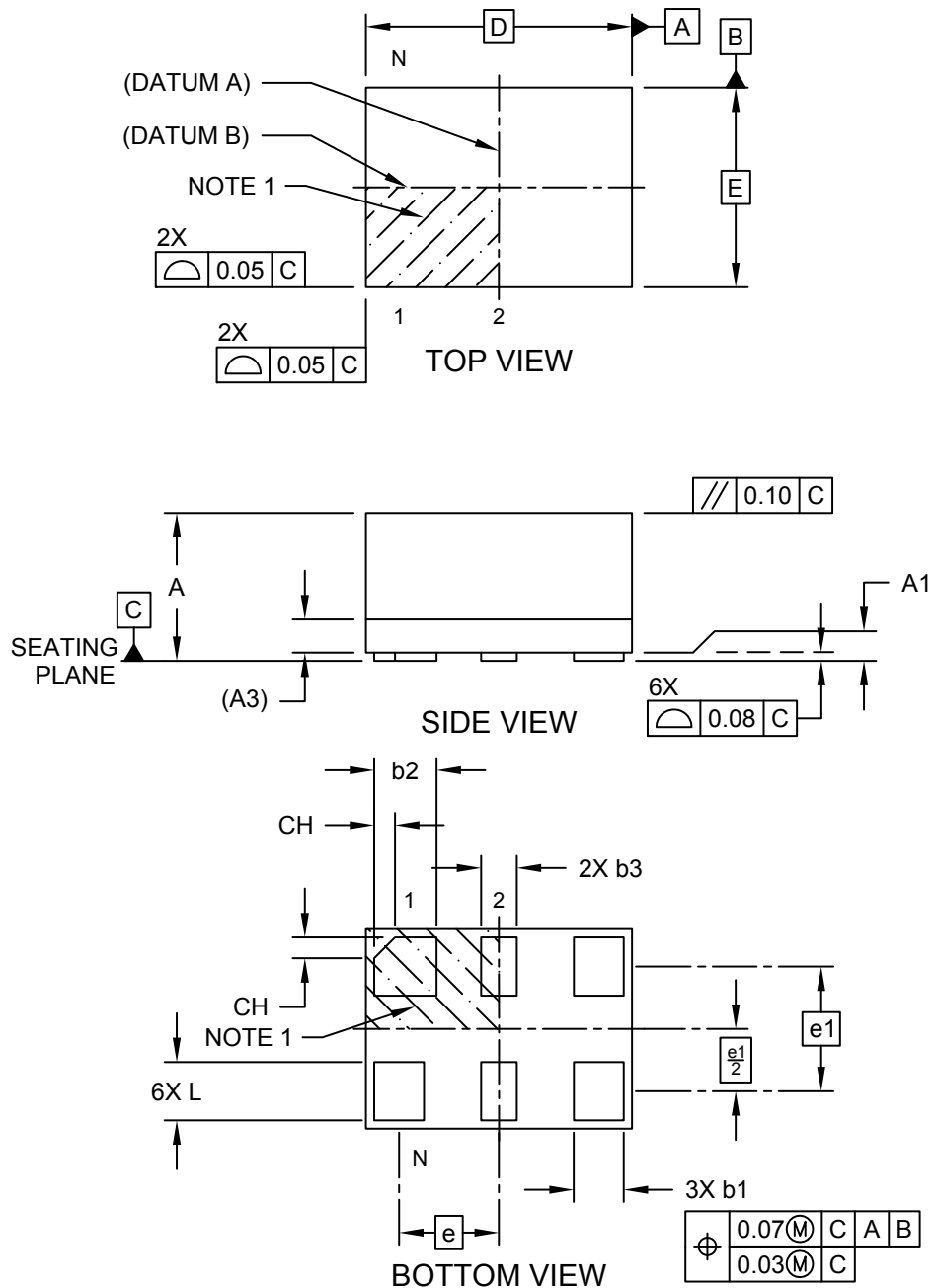

**Package Outlines and Dimensions**

**6-Lead Very Thin Fine Pitch Land Grid Array (AVA) - 1.6x1.2 mm Body [VFLGA]**

**Note:** For the most current package drawings, please see the Microchip Packaging Specification located at <http://www.microchip.com/packaging>

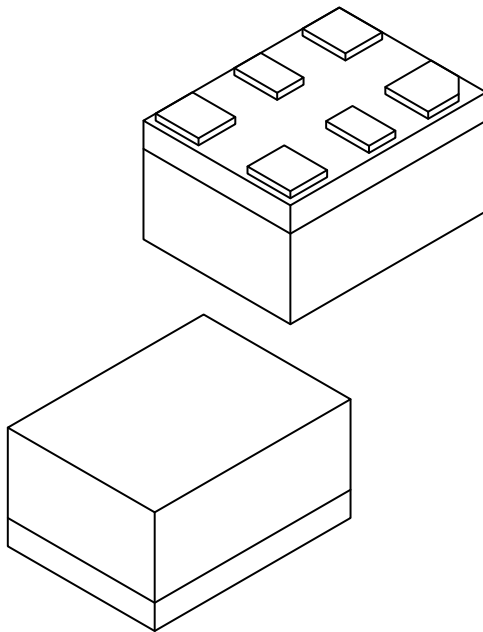

Dimension Limits	Units	MILLIMETERS		
		MIN	NOM	MAX
Number of Terminals	N	6		
Terminal Pitch	e	0.60 BSC		
Terminal Pitch	e1	0.75 BSC		
Overall Height	A	0.79	0.84	0.89
Standoff	A1	0.00	0.02	0.05
Substrate Thickness (with Terminals)	A3	0.20 REF		
Overall Length	D	1.60 BSC		
Overall Width	E	1.20 BSC		
Terminal Width	b1	0.25	0.30	0.35
Terminal Width	b2	0.325	0.375	0.425
Terminal Width	b3	0.20	0.25	0.30
Terminal Length	L	0.30	0.35	0.40
Terminal 1 Index Chamfer	CH	-	0.125	-

Notes:

1. Pin 1 visual index feature may vary, but must be located within the hatched area.
2. Package is saw singulated
3. Dimensioning and tolerancing per ASME Y14.5M

BSC: Basic Dimension. Theoretically exact value shown without tolerances.

REF: Reference Dimension, usually without tolerance, for information purposes only.

---



---

## Footprint Outlines and Dimensions

---



---

### 6-Lead Very Thin Fine Pitch Land Grid Array (AVA) - 1.6x1.2 mm Body [VFLGA]

**Note:** For the most current package drawings, please see the Microchip Packaging Specification located at <http://www.microchip.com/packaging>

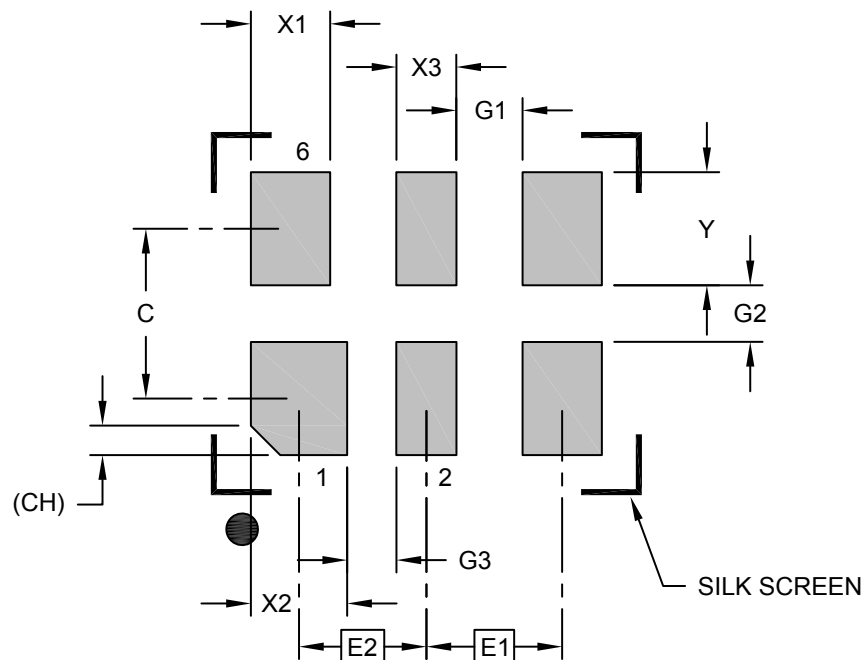

**RECOMMENDED LAND PATTERN**

Dimension Limits	Units	MILLIMETERS		
		MIN	NOM	MAX
Contact Pitch (X3)	E1		0.60 BSC	
Contact Pitch	E2		0.56 BSC	
Contact Spacing	C		0.75	
Contact Width (X3)	X1			0.35
Contact Width	X2			0.43
Contact Width (X2)	X3			0.27
Contact Pad Length (X6)	Y			0.50
Space Between Contacts (X4)	G1	0.29		
Space Between Contacts (X3)	G2	0.25		
Space Between Contacts	G3	0.22		
Contact 1 Index Chamfer	CH	0.13 X 45° REF		

**Notes:**

1. Dimensioning and tolerancing per ASME Y14.5M  
BSC: Basic Dimension. Theoretically exact value shown without tolerances.

**Package Outlines and Dimensions**

**6-Lead Very Thin Fine Pitch Land Grid Array (ATA) - 2.0x1.6 mm Body [VFLGA]**

**Note:** For the most current package drawings, please see the Microchip Packaging Specification located at <http://www.microchip.com/packaging>

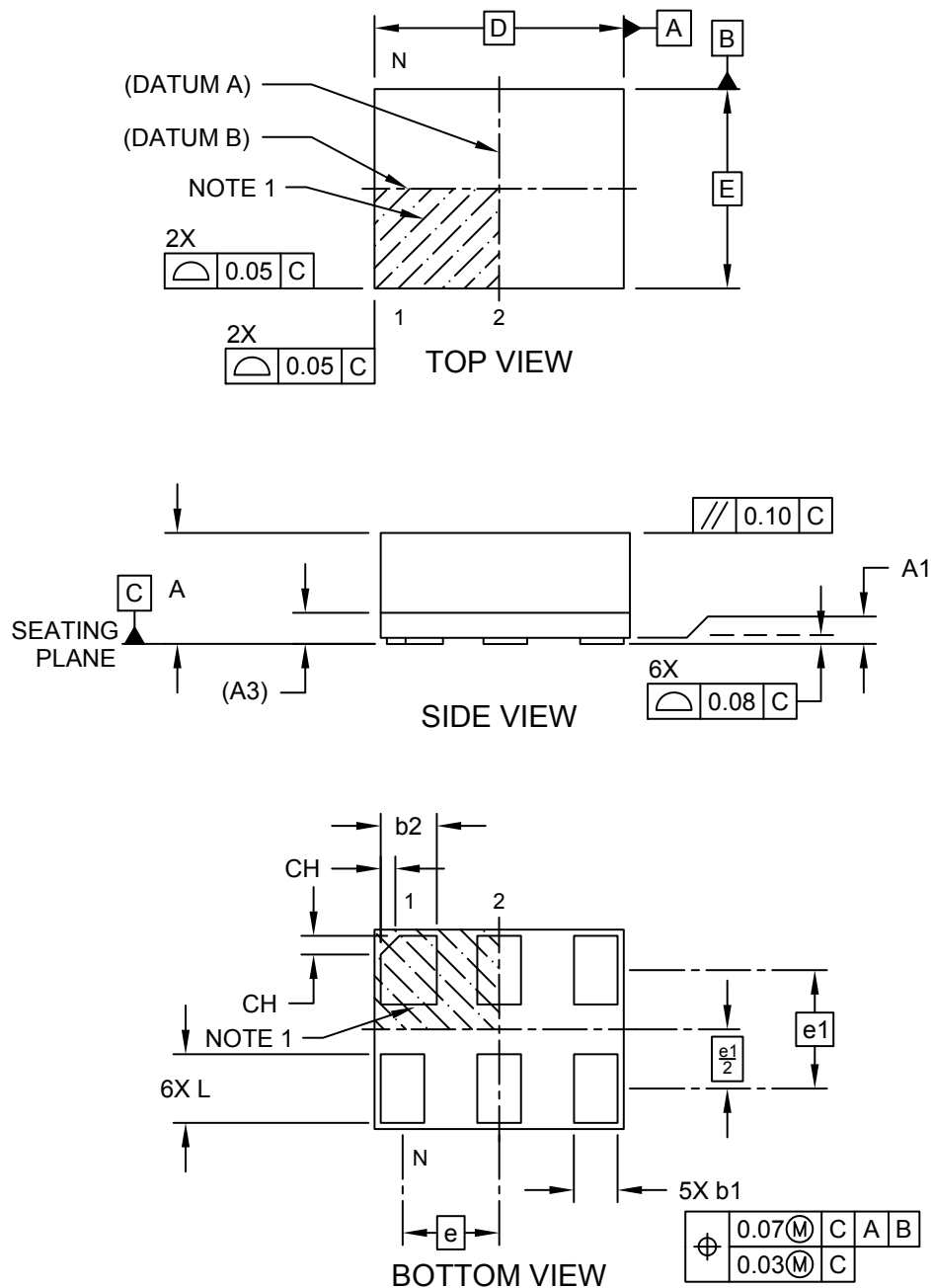

---



---

## Package Outlines and Dimensions

---



---

### 6-Lead Very Thin Fine Pitch Land Grid Array (ATA) - 2.0x1.6 mm Body [VFLGA]

**Note:** For the most current package drawings, please see the Microchip Packaging Specification located at <http://www.microchip.com/packaging>

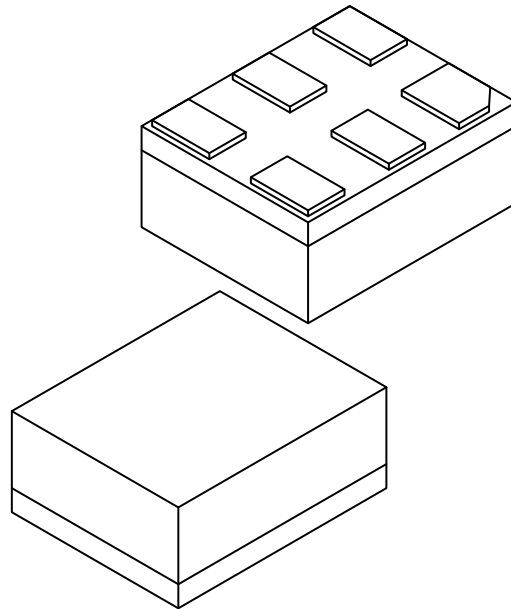

Dimension Limits	Units	MILLIMETERS		
		MIN	NOM	MAX
Number of Terminals	N	6		
Terminal Pitch	e	0.775 BSC		
Terminal Pitch	e1	0.95 BSC		
Overall Height	A	0.79	0.84	0.89
Standoff	A1	0.00	0.02	0.05
Substrate Thickness (with Terminals)	A3	0.20 REF		
Overall Length	D	2.00 BSC		
Overall Width	E	1.60 BSC		
Terminal Width	b1	0.30	0.35	0.40
Terminal Width	b2	0.40	0.45	0.50
Terminal Length	L	0.50	0.55	0.60
Terminal 1 Index Chamfer	CH	-	0.15	-

**Notes:**

1. Pin 1 visual index feature may vary, but must be located within the hatched area.
2. Package is saw singulated
3. Dimensioning and tolerancing per ASME Y14.5M

BSC: Basic Dimension. Theoretically exact value shown without tolerances.

REF: Reference Dimension, usually without tolerance, for information purposes only.

**Footprint Outlines and Dimensions**

**6-Lead Very Thin Fine Pitch Land Grid Array (ATA) - 2.0x1.6 mm Body [VFLGA]**

**Note:** For the most current package drawings, please see the Microchip Packaging Specification located at <http://www.microchip.com/packaging>

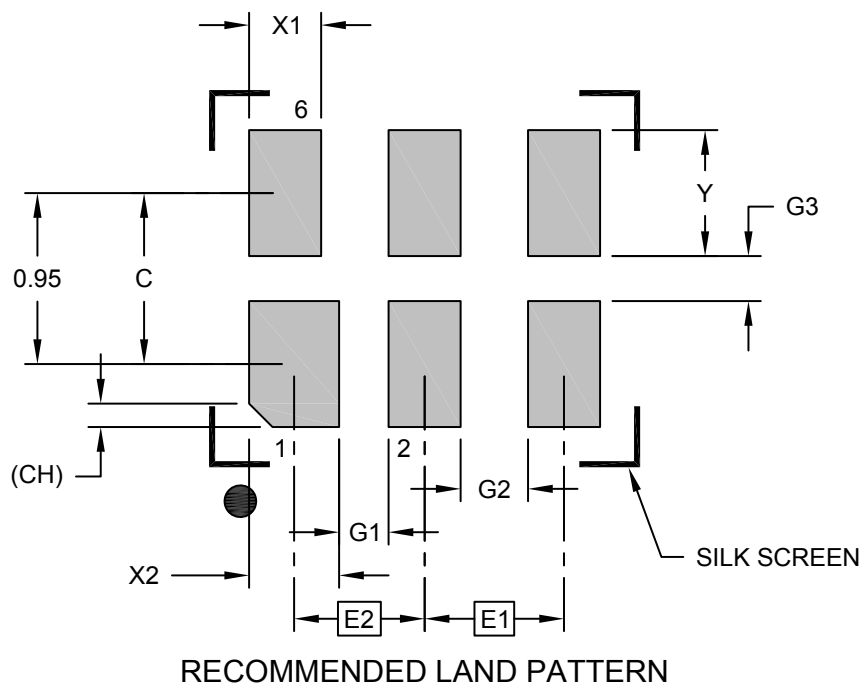

Dimension Limits	Units	MILLIMETERS		
		MIN	NOM	MAX
Contact Pitch	E1		0.78 BSC	
Contact Pitch	E2		0.73 BSC	
Contact Spacing	C		0.95	
Contact Width (X4)	X1			0.40
Contact Width (X2)	X2			0.45
Contact Pad Length (X6)	Y			0.70
Space Between Contacts (X4)	G1	0.28		
Space Between Contacts (X3)	G2	0.38		
Space Between Contacts (X3)	G3	0.25		
Contact 1 Index Chamfer	CH	0.13 X 45° REF		

Notes:

1. Dimensioning and tolerancing per ASME Y14.5M  
BSC: Basic Dimension. Theoretically exact value shown without tolerances.

**Package Outlines and Dimensions**

**6-Lead Very Thin Fine Pitch Land Grid Array (AWA) - 2.5x2.0 mm Body [VFLGA]**

**Note:** For the most current package drawings, please see the Microchip Packaging Specification located at <http://www.microchip.com/packaging>

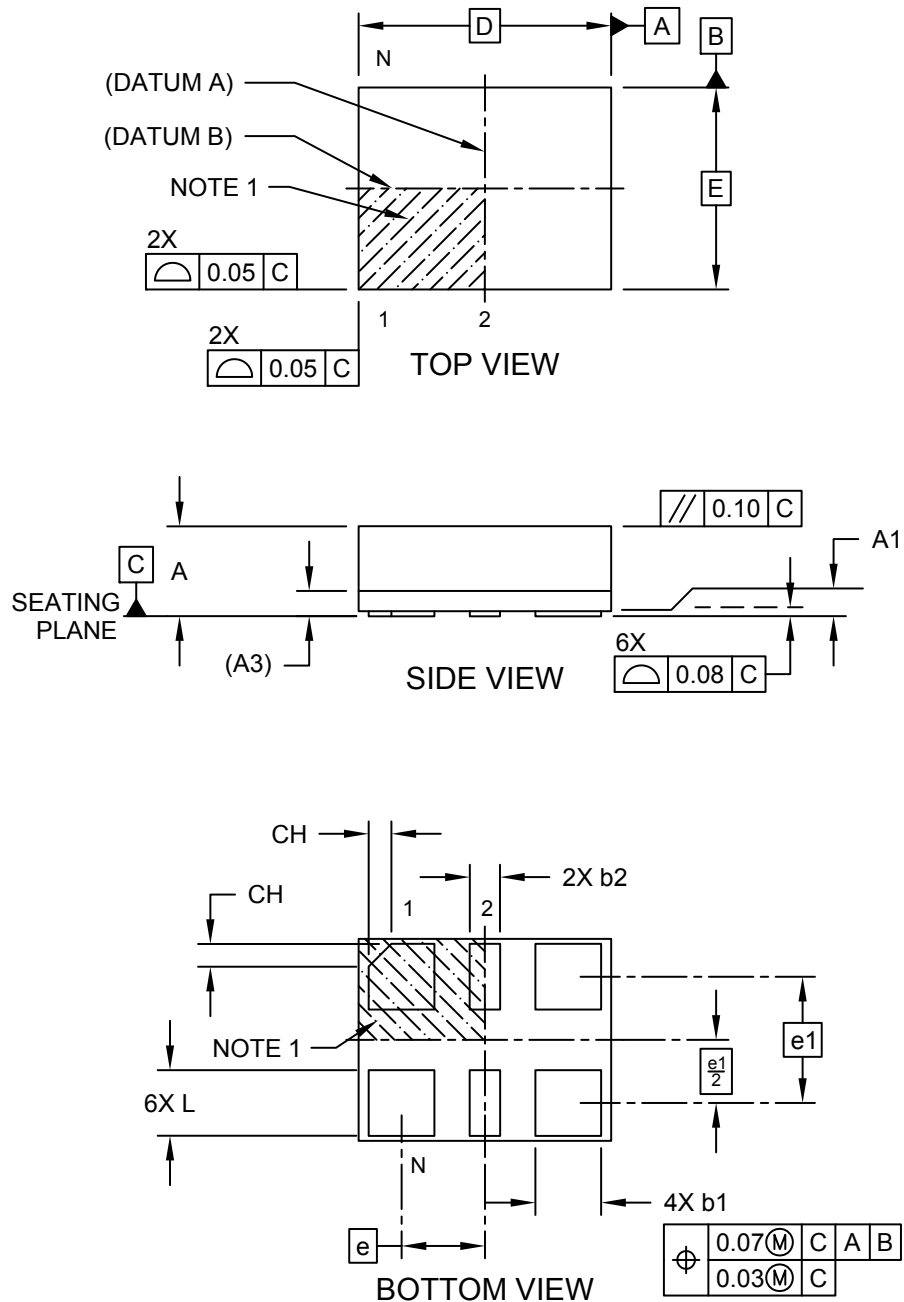

**Package Outlines and Dimensions**

**6-Lead Very Thin Fine Pitch Land Grid Array (AWA) - 2.5x2.0 mm Body [VFLGA]**

**Note:** For the most current package drawings, please see the Microchip Packaging Specification located at <http://www.microchip.com/packaging>

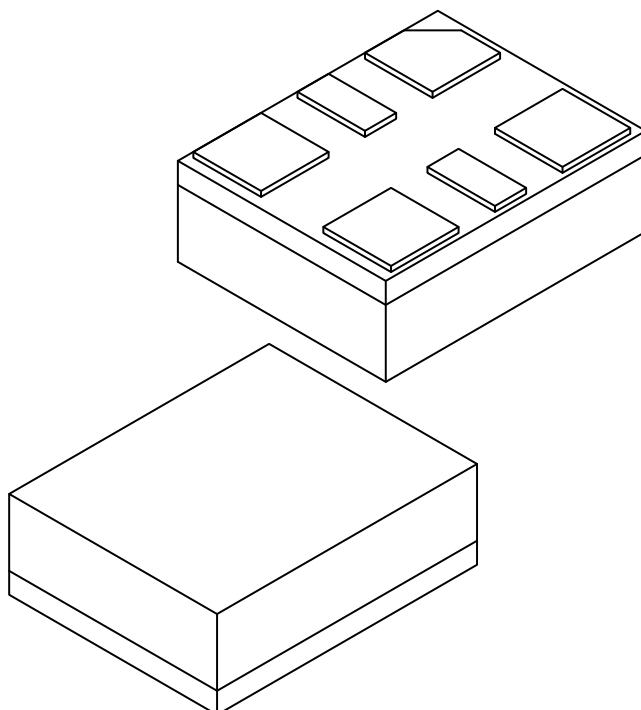

Dimension Limits	Units	MILLIMETERS		
		MIN	NOM	MAX
Number of Terminals	N	6		
Terminal Pitch	e	0.825 BSC		
Terminal Pitch	e1	1.25 BSC		
Overall Height	A	0.79	0.84	0.89
Standoff	A1	0.00	0.02	0.05
Substrate Thickness (with Terminals)	A3	0.20 REF		
Overall Length	D	2.50 BSC		
Overall Width	E	2.00 BSC		
Terminal Width	b1	0.60	0.65	0.70
Terminal Width	b2	0.25	0.30	0.35
Terminal Length	L	0.60	0.65	0.70
Terminal 1 Index Chamfer	CH	-	0.225	-

Notes:

1. Pin 1 visual index feature may vary, but must be located within the hatched area.
2. Package is saw singulated
3. Dimensioning and tolerancing per ASME Y14.5M

BSC: Basic Dimension. Theoretically exact value shown without tolerances.

REF: Reference Dimension, usually without tolerance, for information purposes only.



---



---

## Footprint Outlines and Dimensions

---



---

### 6-Lead Very Thin Fine Pitch Land Grid Array (AWA) - 2.5x2.0 mm Body [VFLGA]

**Note:** For the most current package drawings, please see the Microchip Packaging Specification located at <http://www.microchip.com/packaging>

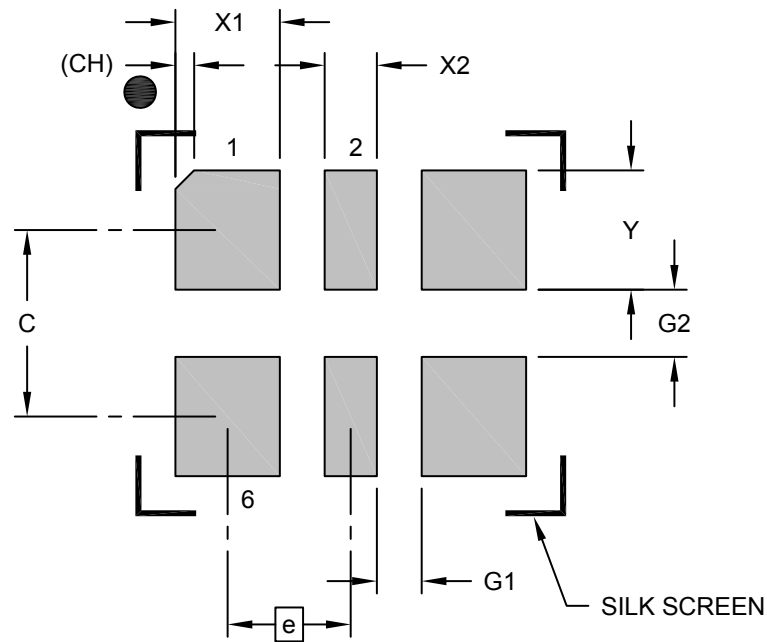

**RECOMMENDED LAND PATTERN**

Dimension Limits	Units	MILLIMETERS		
		MIN	NOM	MAX
Contact Pitch	E	0.825 BSC		
Contact Spacing	C	1.25 BSC		
Contact Width (X4)	X1			0.70
Contact Width (X2)	X2			0.35
Contact Pad Length (X6)	Y			0.80
Space Between Contacts (X4)	G1	0.30		
Space Between Contacts (X3)	G2	0.45		
Contact 1 Index Chamfer	CH	0.13 X 45° REF		

**Notes:**

- Dimensioning and tolerancing per ASME Y14.5M  
BSC: Basic Dimension. Theoretically exact value shown without tolerances.

**Package Outlines and Dimensions**

**56L Very Thin Fine Pitch Land Grid Array (4W) - 7x7x0.9 mm Body [VFLGA]  
With Exposed Pads**

**Note:** For the most current package drawings, please see the Microchip Packaging Specification located at <http://www.microchip.com/packaging>

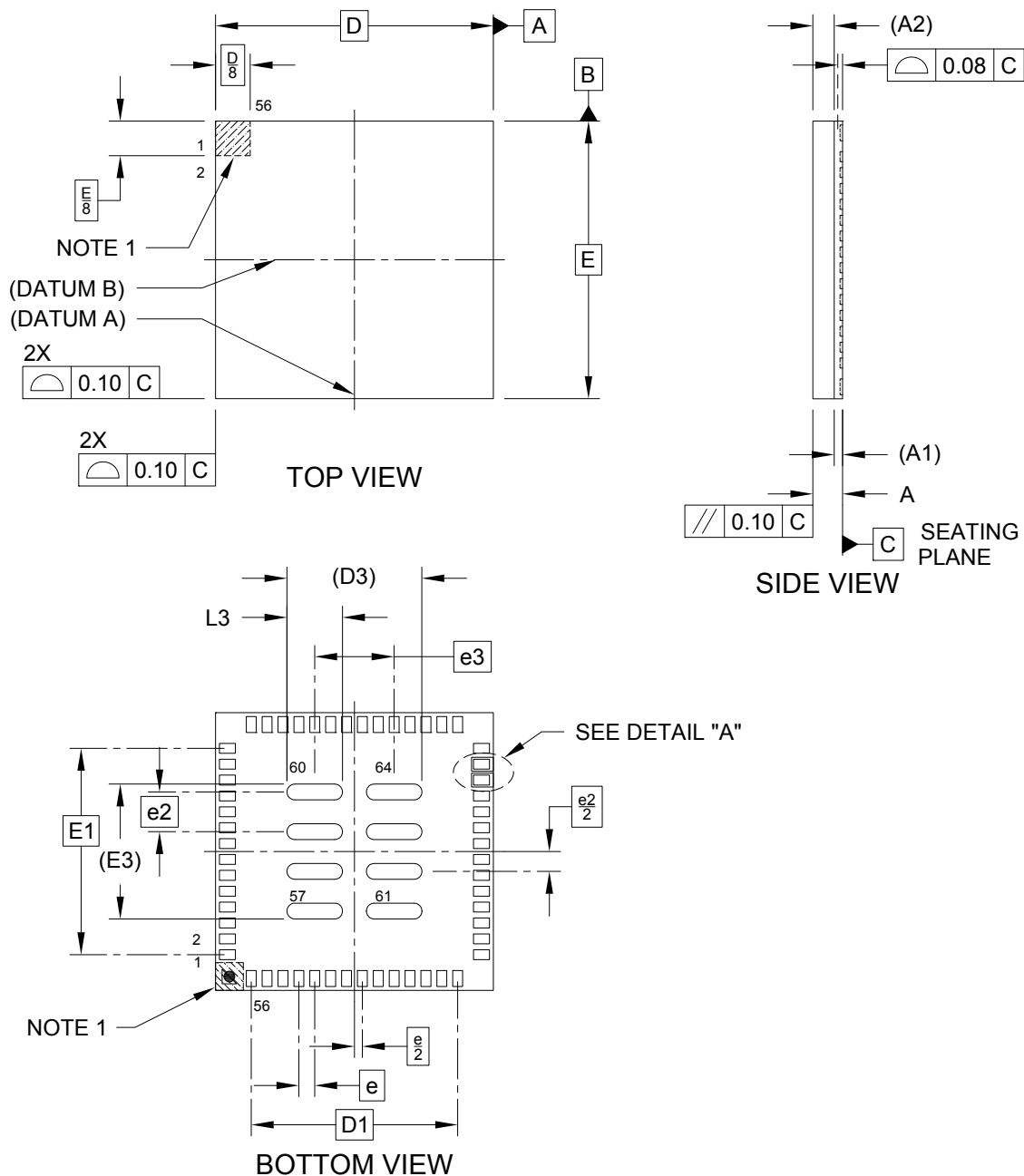

---



---

## Package Outlines and Dimensions

---



---

### 56L Very Thin Fine Pitch Land Grid Array (4W) - 7x7x0.9 mm Body [VFLGA] With Exposed Pads

**Note:** For the most current package drawings, please see the Microchip Packaging Specification located at <http://www.microchip.com/packaging>

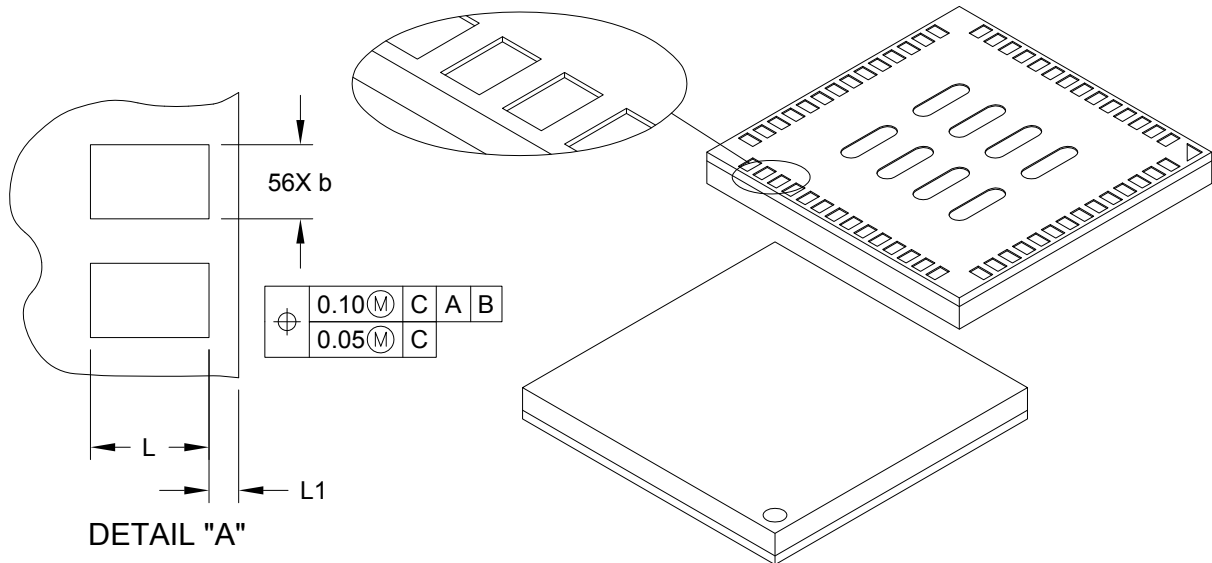

		Units	MILLIMETERS		
Dimension Limits			MIN	NOM	MAX
Number of Terminals	N		56		
Pitch	e		0.40 BSC		
Exposed Pads Pitch	e2		1.00 BSC		
Exposed Pads Pitch	e3		2.00 BSC		
Overall Height	A	-	-	-	0.90
Substrate Thickness	A1		0.21 REF		
Mold Cap Height	A2		0.54 REF		
Overall Length	D		7.00 BSC		
Overall Terminal Pitch	D1		5.20 BSC		
Exposed Pads Overall Length	D3		3.40 REF		
Overall Width	E		7.00 BSC		
Overall Terminal Pitch	E1		5.20 BSC		
Overall Terminal Pitch	E1		3.40 REF		
Terminal Width	b	0.20	0.25	0.30	
Exposed Pad Width	b3	0.35	0.40	0.45	
Terminal Length	L	0.35	0.40	0.45	
Terminal Pullback	L1	-	0.10	-	
Exposed Pad Length	L3	1.35	1.40	1.45	

**Notes:**

1. Pin 1 visual index feature may vary, but must be located within the hatched area.
2. Package is saw singulated
3. Dimensioning and tolerancing per ASME Y14.5M
  - BSC: Basic Dimension. Theoretically exact value shown without tolerances.
  - REF: Reference Dimension, usually without tolerance, for information purposes only.

**Footprint Outlines and Dimensions**

**56L Very Thin Fine Pitch Land Grid Array (4W) - 7x7x0.9 mm Body [VFLGA]  
With Exposed Pads**

**Note:** For the most current package drawings, please see the Microchip Packaging Specification located at <http://www.microchip.com/packaging>

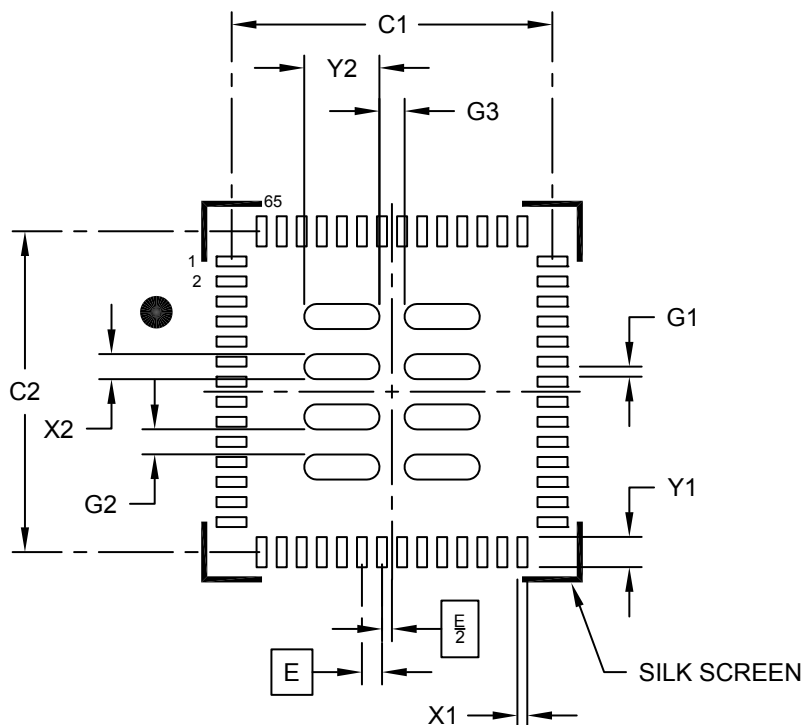

**RECOMMENDED LAND PATTERN**

Dimension Limits	Units	MILLIMETERS		
		MIN	NOM	MAX
Contact Pitch	E	0.40 BSC		
Center Pad Width (X8)	X2			0.50
Center Pad Length (X8)	Y2			1.50
Contact Pad Spacing	C1		6.40	
Contact Pad Spacing	C2		6.40	
Contact Pad Width (X56)	X1			0.20
Contact Pad Length (X56)	Y1			0.60
Contact Pad to Pad (X52)	G1	0.20		
Center Pads Clearance (X6)	G2		0.50	
Center Pads Clearance (X4)	G3		0.50	

**Notes:**

1. Dimensioning and tolerancing per ASME Y14.5M  
BSC: Basic Dimension. Theoretically exact value shown without tolerances.
2. For best soldering results, thermal vias, if used, should be filled or tented to avoid solder loss during reflow process

**Package Outlines and Dimensions**

**68L Very Thin Fine Pitch Land Grid Array (2W) - 8x8x0.9 mm Body [VFLGA]  
With Exposed Pads; ISSC Legacy Package**

**Note:** For the most current package drawings, please see the Microchip Packaging Specification located at <http://www.microchip.com/packaging>

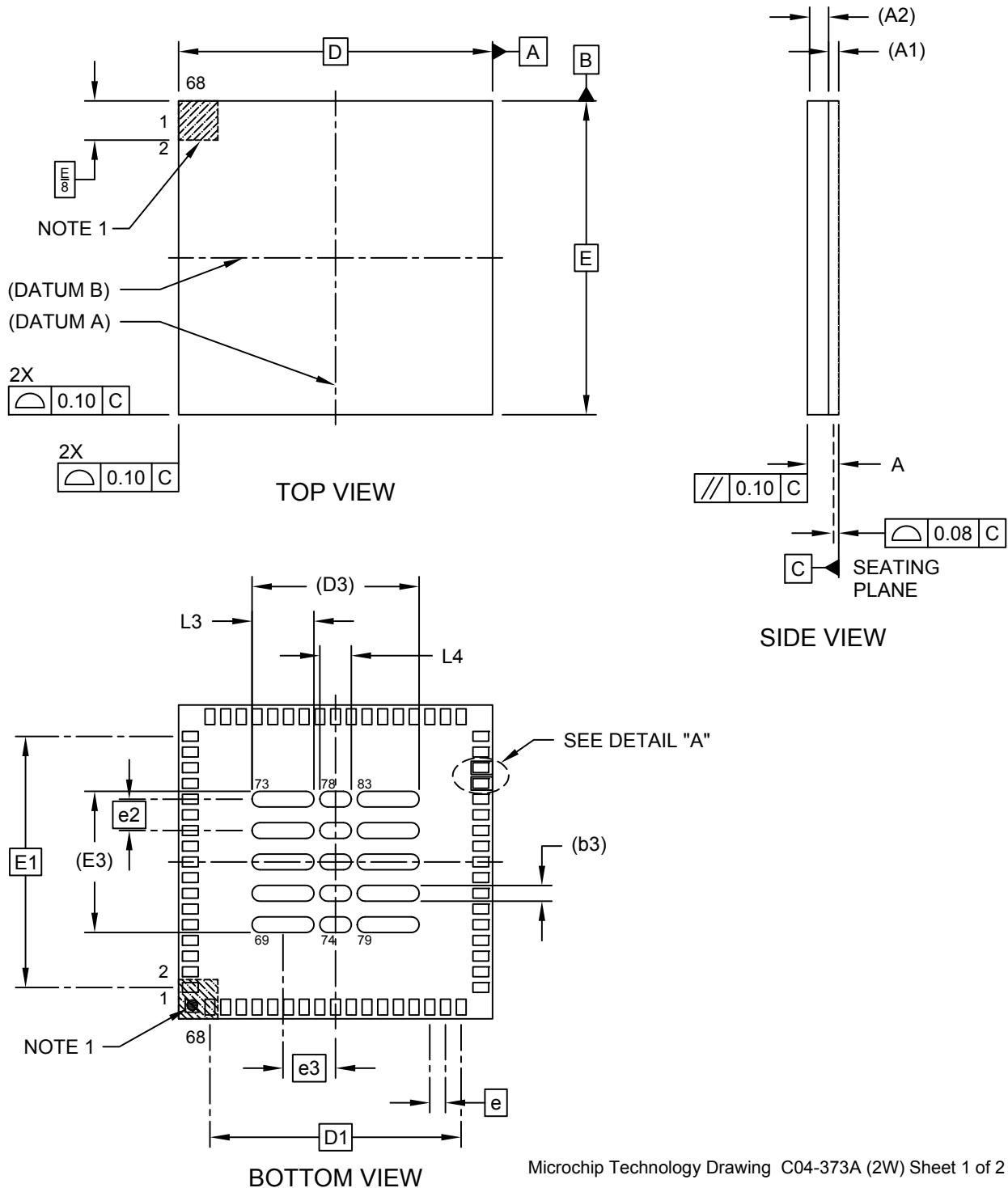

Microchip Technology Drawing C04-373A (2W) Sheet 1 of 2

## Package Outlines and Dimensions

### 68L Very Thin Fine Pitch Land Grid Array (2W) - 8x8x0.9 mm Body [VFLGA] With Exposed Pads; ISSC Legacy Package

**Note:** For the most current package drawings, please see the Microchip Packaging Specification located at <http://www.microchip.com/packaging>

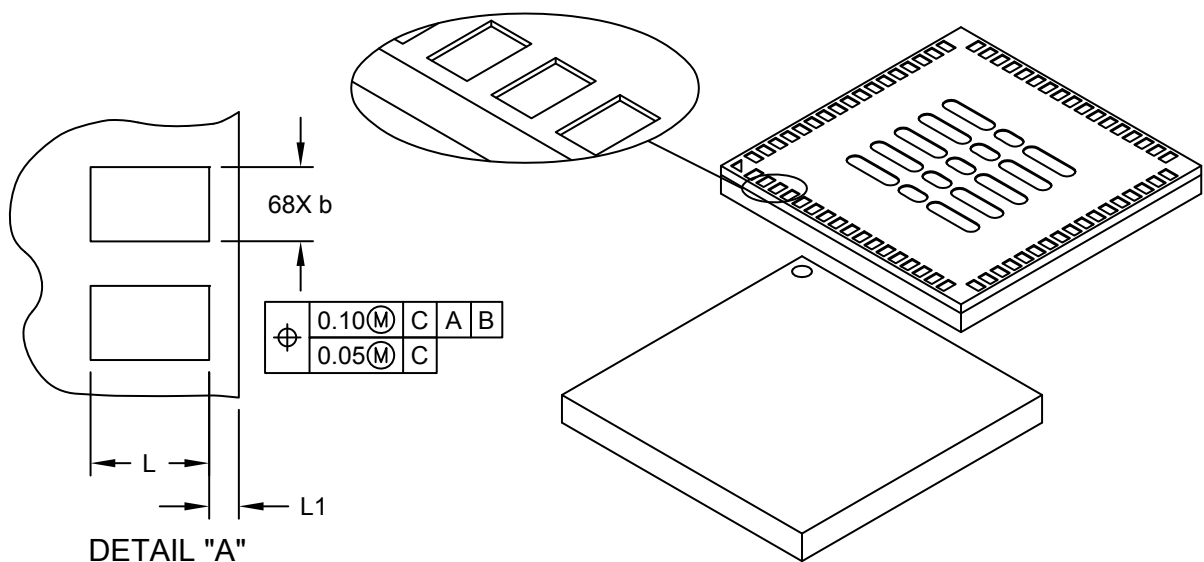

Dimension Limits	Units	MILLIMETERS		
		MIN	NOM	MAX
Number of Terminals	N	68		
Pitch	e	0.40 BSC		
Exposed Pads Pitch	e2	0.80 BSC		
Exposed Pads Pitch	e3	1.34 BSC		
Overall Height	A	0.80	0.90	1.00
Substrate Thickness	A1	0.26 REF		
Mold Cap Height	A2	0.54 REF		
Overall Length	D	8.00 BSC		
Overall Terminal Pitch	D1	6.40 BSC		
Exposed Pads Overall Length	D3	4.25 REF		
Overall Width	E	8.00 BSC		
Overall Terminal Pitch	E1	6.40 BSC		
Overall Terminal Pitch	E3	3.60 REF		
Terminal Width	b	0.20	0.25	0.30
Exposed Pad Width	b3	0.40 REF		
Terminal Length	L	0.35	0.40	0.45
Terminal Pullback	L1	-	0.10	-
Exposed Pad Length	L3	1.575 REF		
Exposed Pad Length	L4	0.80 REF		

**Notes:**

1. Pin 1 visual index feature may vary, but must be located within the hatched area.
2. Package is saw singulated
3. Dimensioning and tolerancing per ASME Y14.5M
  - BSC: Basic Dimension. Theoretically exact value shown without tolerances.
  - REF: Reference Dimension, usually without tolerance, for information purposes only.

---



---

## Footprint Outlines and Dimensions

---



---

### 68L Very Thin Fine Pitch Land Grid Array (2W) - 8x8x0.9 mm Body [VFLGA] With Exposed Pads; ISSC Legacy Package

**Note:** For the most current package drawings, please see the Microchip Packaging Specification located at <http://www.microchip.com/packaging>

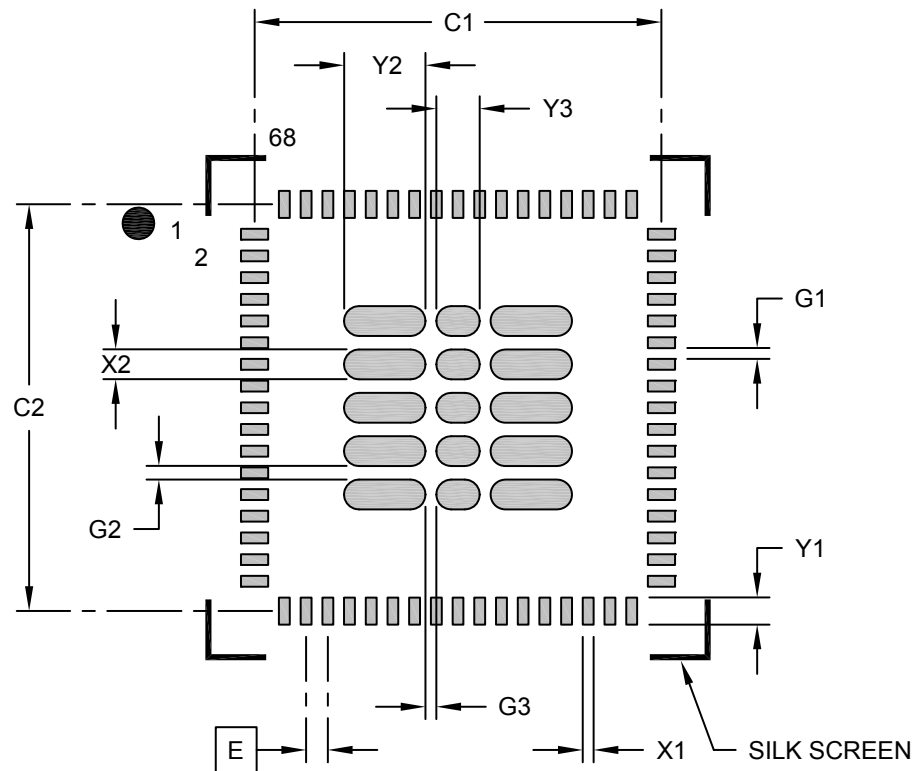

#### RECOMMENDED LAND PATTERN

Dimension Limits	Units	MILLIMETERS		
		MIN	NOM	MAX
Contact Pitch	E	0.40 BSC		
Center Pad Width (X10)	X2			0.55
Center Pad Length (X10)	Y2			1.50
Center Pad Length (X5)	Y3			0.80
Contact Pad Spacing	C1		7.50	
Contact Pad Spacing	C2		7.50	
Contact Pad Width (X68)	X1			0.20
Contact Pad Length (X68)	Y1			0.50
Contact Pad to Pad (X68)	G1	0.20		
Center Pads Clearance (X12)	G2	0.20		
Center Pads Clearance (X10)	G3	0.20		

**Notes:**

1. Dimensioning and tolerancing per ASME Y14.5M  
BSC: Basic Dimension. Theoretically exact value shown without tolerances.
2. For best soldering results, thermal vias, if used, should be filled or tented to avoid solder loss during reflow process

**Package Outlines and Dimensions**

**68L Very Thin Fine Pitch Land Grid Array (7W) - 8x8x0.9 mm Body [VFLGA]  
With Exposed Pads; ISSC Legacy Package**

**Note:** For the most current package drawings, please see the Microchip Packaging Specification located at <http://www.microchip.com/packaging>

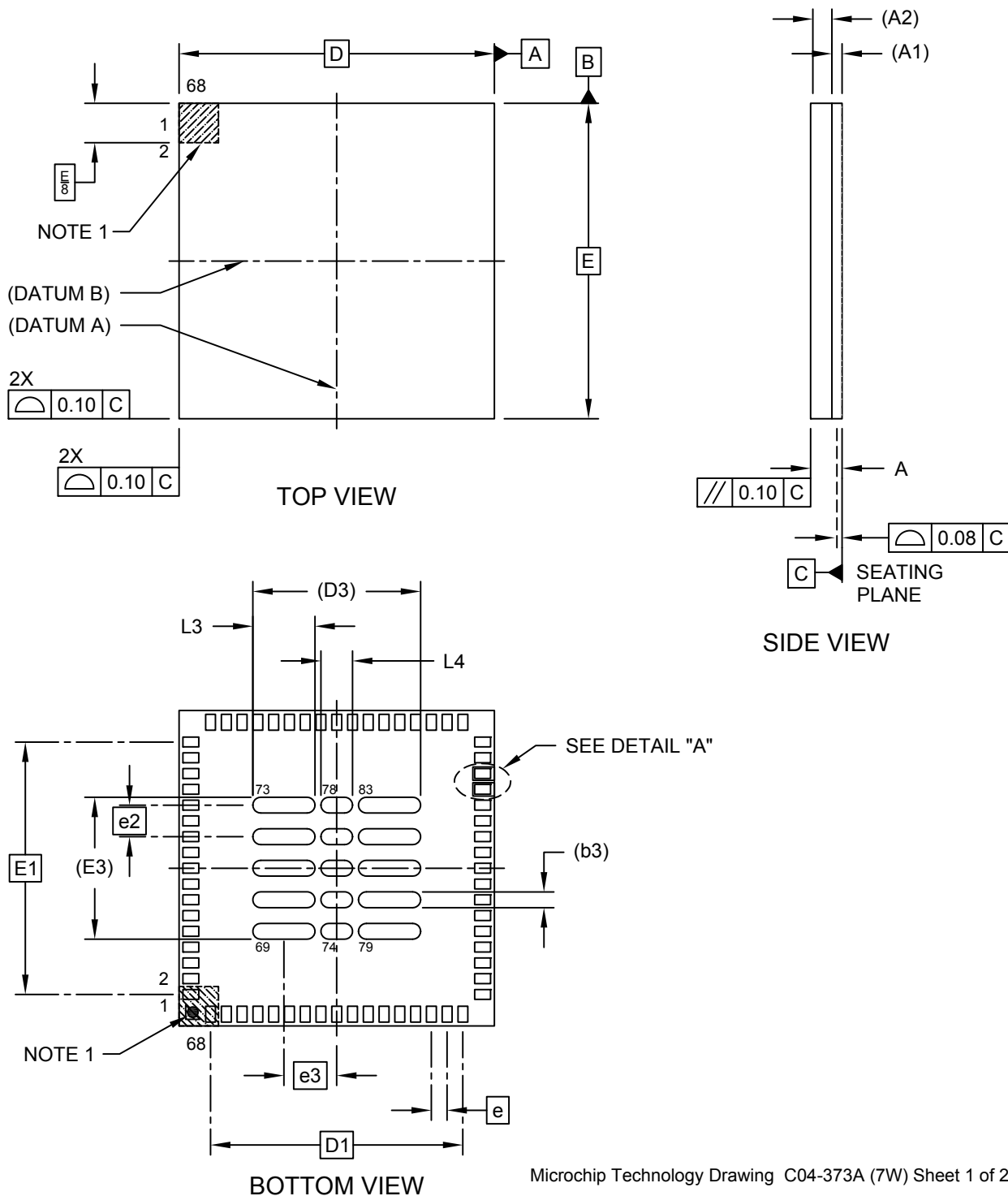

Microchip Technology Drawing C04-373A (7W) Sheet 1 of 2



---



---

## Package Outlines and Dimensions

---



---

### 68L Very Thin Fine Pitch Land Grid Array (7W) - 8x8x0.9 mm Body [VFLGA] With Exposed Pads; ISSC Legacy Package

**Note:** For the most current package drawings, please see the Microchip Packaging Specification located at <http://www.microchip.com/packaging>

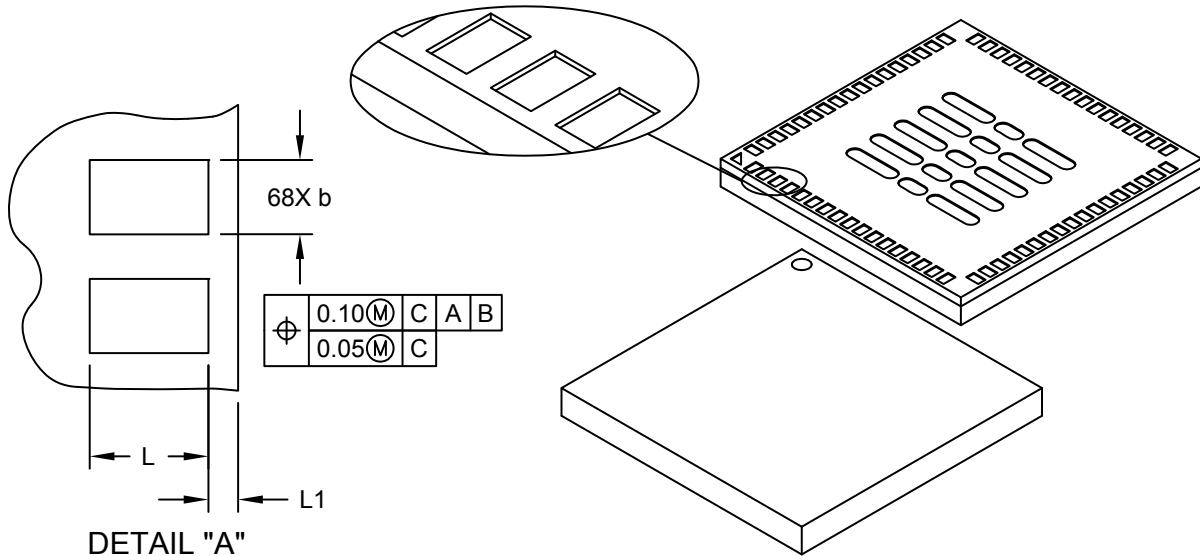

		MILLIMETERS		
Units				
Dimension Limits		MIN	NOM	MAX
Number of Terminals	N	68		
Pitch	e	0.40 BSC		
Exposed Pads Pitch	e2	0.80 BSC		
Exposed Pads Pitch	e3	1.34 BSC		
Overall Height	A	0.80	0.90	1.00
Substrate Thickness	A1	0.26 REF		
Mold Cap Height	A2	0.54 REF		
Overall Length	D	8.00 BSC		
Overall Terminal Pitch	D1	6.40 BSC		
Exposed Pads Overall Length	D3	4.25 REF		
Overall Width	E	8.00 BSC		
Overall Terminal Pitch	E1	6.40 BSC		
Overall Terminal Pitch	E3	3.60 REF		
Terminal Width	b	0.20	0.25	0.30
Exposed Pad Width	b3	0.40 REF		
Terminal Length	L	0.35	0.40	0.45
Terminal Pullback	L1	-	0.10	-
Exposed Pad Length	L3	1.575 REF		
Exposed Pad Length	L4	0.80 REF		

**Notes:**

1. Pin 1 visual index feature may vary, but must be located within the hatched area.
2. Package is saw singulated
3. Dimensioning and tolerancing per ASME Y14.5M
  - BSC: Basic Dimension. Theoretically exact value shown without tolerances.
  - REF: Reference Dimension, usually without tolerance, for information purposes only.

**Footprint Outlines and Dimensions**

**68L Very Thin Fine Pitch Land Grid Array (7W) - 8x8x0.9 mm Body [VFLGA]  
With Exposed Pads; ISSC Legacy Package**

**Note:** For the most current package drawings, please see the Microchip Packaging Specification located at <http://www.microchip.com/packaging>

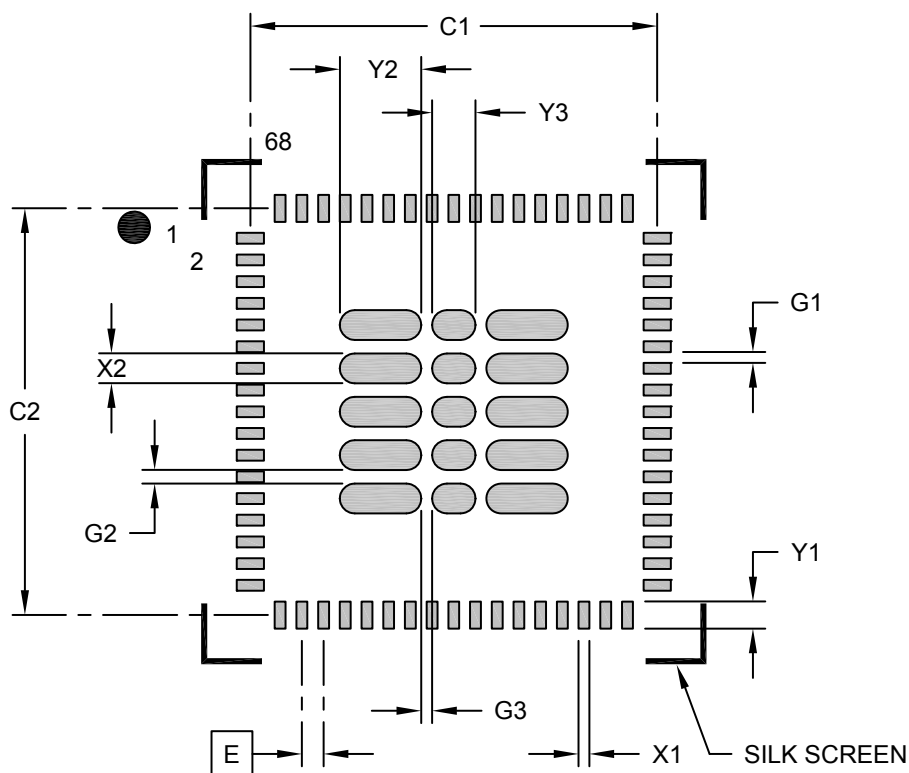

**RECOMMENDED LAND PATTERN**

Dimension Limits	Units	MILLIMETERS		
		MIN	NOM	MAX
Contact Pitch	E	0.40 BSC		
Center Pad Width (X10)	X2			0.55
Center Pad Length (X10)	Y2			1.50
Center Pad Length (X5)	Y3			0.80
Contact Pad Spacing	C1		7.50	
Contact Pad Spacing	C2		7.50	
Contact Pad Width (X68)	X1			0.20
Contact Pad Length (X68)	Y1			0.50
Contact Pad to Pad (X68)	G1	0.20		
Center Pads Clearance (X12)	G2	0.20		
Center Pads Clearance (X10)	G3	0.20		

**Notes:**

1. Dimensioning and tolerancing per ASME Y14.5M  
BSC: Basic Dimension. Theoretically exact value shown without tolerances.
2. For best soldering results, thermal vias, if used, should be filled or tented to avoid solder loss during reflow process

# PACKAGING SPECIFICATION

---

## LEGACY PACKAGE TABLE OF CONTENTS

---

### Legacy SST Package Drawings & Specifications

---

PDIP .....	1125	UQFN .....	1169
PLCC .....	1129	VQFN.....	1177
SOIC.....	1133	XQFN.....	1179
TBGA.....	1139	X2QFN.....	1183
TFBGA.....	1141	WQFN.....	1185
WFBGA.....	1145	USON .....	1189
XFLGA.....	1153	WSON .....	1193
TQFP .....	1159	XSON .....	1197
TSOP.....	1161		

### Legacy SMSC Package Drawings & Specifications

---

DFN .....	1203	QLeX .....	1301
DQFN Family.....	1207	SOT-23 .....	1305
DS Family.....	1215	SOIC.....	1307
LBGA.....	1219	SSOP.....	1311
DSA .....	1221	TDFN.....	1313
LFBGA.....	1223	TFBGA.....	1315
LGA.....	1233	TSSOP .....	1319
LQFP .....	1237	TQFP .....	1321
MQFP .....	1241	UFBGA .....	1325
PLCC .....	1245	VFBGA.....	1327
QFN.....	1247	WFBGA.....	1331
SQFN.....	1279	VTQFP.....	1333
QFP .....	1293	XVTQFP .....	1337
SIP.....	1299		

### Legacy Supertex Package Drawings & Specifications

---

BCC .....	1341	LQFP .....	1369
BD.....	1345	MQFP .....	1373
Cerpac.....	1347	MSOP .....	1375
DFN .....	1349	PDIP .....	1379
LLGA.....	1361	PLCC .....	1385
LFGA .....	1363	PQFP.....	1389

# PACKAGING SPECIFICATION

---

QFN .....	1395	TO-92 .....	1439
QSOP .....	1417	TO-220 .....	1443
SOIC .....	1419	TO-243 .....	1447
SOT-23 .....	1425	TO-252 .....	1449
SOT-223 .....	1429	TQFP .....	1451
SOW .....	1431	TSSOP .....	1453
TO-39 .....	1437		

## Legacy Micrel Package Drawings & Specifications

---

CDFN .....	1457	PBGA .....	1675
CERQUAD .....	1465	PDIP .....	1679
CERSiP .....	1469	PKQFN .....	1693
CLLCC .....	1475	PLCC .....	1695
CQFN .....	1477	PQFP .....	1699
CTDFN .....	1481	QFN .....	1703
CTQFN .....	1485	QSOP .....	1745
DFN .....	1487	SC70 .....	1749
FBGA .....	1523	SOIC .....	1755
DFN .....	1525	SOT .....	1767
FQFN .....	1531	SPAK .....	1775
FTDFN .....	1565	SSOP .....	1779
FTQFN .....	1573	TDFN .....	1785
GJQFN .....	1595	TO220-TO263 .....	1801
GKQFN .....	1599	TQFN .....	1815
H3QFN .....	1603	TQFP .....	1821
H4QFN .....	1617	TSOT .....	1831
HDFN .....	1625	TSSOP .....	1835
HJDFN .....	1629	UTDFN .....	1849
HKQFN .....	1633	WLCSP .....	1851
HQFN .....	1635	WQFN .....	1863
LDFN .....	1637	XTDFN .....	1867
LFBGA .....	1639		
LGA .....	1643		
LQFN .....	1649		
LQFP .....	1653		
MSOP .....	1667		
P2QFN .....	1673		

# PACKAGING SPECIFICATION

---

<b>Appendix A: Revision History .....</b>	<b>1871</b>
<b>Appendix B: Control Dimensions .....</b>	<b>1891</b>
<b>Appendix C: Geometric Dimensioning and Tolerancing .....</b>	<b>1893</b>
<b>Overview of Microchip Die/Wafer Support.....</b>	<b>1899</b>
<b>Worldwide Sales and Service.....</b>	<b>1902</b>

# PACKAGING SPECIFICATION

---

NOTES:

---



---

## Package Index

---



---

### LEGACY SST PACKAGE DRAWINGS & SPECIFICATIONS

#### PDIP

14022_32L-pdip_15mm2-PH .....	1126
14028_40L-pdip_600-PI .....	1127

#### PLCC

14023_32L-plcc-NH .....	1130
14033_44L-plcc-NJ .....	1131

#### SOIC

14003_08L-soic-5x6-SA .....	1134
14004_08L-soic-5x8-S3A .....	1135
14005_08L-soic-EIAJ-S2A .....	1136
14013_16L-soic-SC .....	1137

#### TBGA

14020_24L-tbga-T4D-6x8 .....	1140
------------------------------	------

#### TFBGA

14035_48L-tfbga-B3K-6x8-450mic .....	1142
14034_48L-tfbga-B1K-8x10-450mic .....	1143

#### WFBGA

14026_34L-wfbga-MM-4x6-32mic-1 .....	1146
14027_34L-wfbga-MAM-4x6-32mic-1 .....	1147
14037_48L-wfbga-M1Q-4x6-32mic .....	1148
14038_48L-wfbga-M2Q-5x6-32mic .....	1149
14039_48L-wfbga-MAQ-4x6-32mic .....	1150
14040_48L-wfbga-MBQ-5x6-32mic .....	1151

#### XFLGA

14041_48L-xflga-C1Q-4x6-29mic .....	1154
14043_48L-xflga-CAQ-4x6-29mic .....	1155
14042_48L-xflga-C2Q-5x6-29mic .....	1156
14044_48L-xflga-CBQ-5x6-29mic .....	1157

#### TQFP

14032_44L-tqfp_10x10-TQJ .....	1160
--------------------------------	------

#### TSOP

14024_32L-tsop-EH .....	1162
14025_32L-tsop-WH .....	1163
14029_40L-tsop-EI .....	1164

---



---

## Package Index

---



---

14030_40L-tsop-WI.....	1165
14036_48L-tsop-EK.....	1166
14045_56L-tsop-EN.....	1167

### UQFN

14001_06L-uqfn-3x1mm6-QU6.....	1170
14011_12L-uqfn-2x2-QUB.....	1171
14014_16L-uqfn-3x3-QUC.....	1172
14019_20L-uqfn_3x3-Q3D.....	1173
0252_20L-uqfn-4x4x0-55 1of2.....	1174

### VQFN

14015_16L-vqfn-3x3-QVC.....	1178
-----------------------------	------

### XQFN

14012_12L-xqfn-2x2-QXB.....	1180
14018_16L-xqfn-3x3-QXC.....	1181

### X2QFN

14017_16L-x2qfn-2mm5x2mm5-Q3C.....	1184
------------------------------------	------

### WQFN

14016_16L-wqfn-3x3-QC.....	1186
14021_24L-wqfn-4x4-QD.....	1187
14031_40L-wqfn-6x6-QL.....	1188

### USON

14006_08L-uson-2x2-QU8pdf.....	1190
14007_08L-uson-2x2-QUA.....	1191

### WSON

14008_08L-wson-5x6-QA.....	1194
14009_08L-wson-6x8-Q2A.....	1195

### XSON

14002_06L-xson-1mm5x1mm5-QX6.....	1198
14010_08L-xson-2x2-QX8.....	1199



---



---

## Package Index

---



---

### LEGACY SMSC PACKAGE DRAWINGS & SPECIFICATIONS

#### DFN

10L-DFN-162304-3x3B-05P-rB--1of2.....	1204
---------------------------------------	------

#### DQFN FAMILY

124L-DQFN-10x10B-54eP--rA .....	1208
124L-DQFN-10x10B-69eP--rC .....	1209
132L-DQFN-5004-11x11mm--rB--1of2 .....	1210
156L-DQFN51-12x12B-05P--rE--1of2.....	1212

#### DS FAMILY

25L-DS-2x2B-04P-rE.....	1216
30L-DS-04P-rB .....	1217

#### LBGA

256L-LBGA-17x17B-1P--rC- .....	1220
--------------------------------	------

#### DSA

30L-DSA-04P-rB.....	1222
---------------------	------

#### LFBGA

100L-LFBGA-10x10B-08P-rC.....	1224
156L-LFBGA-11x11B-08P--rC.....	1225
169L-LFBGA-11x11B-08P--rB .....	1226
176L-LFBGA-10x10B-065P--rD .....	1227
196L-LFBGA-10x10B-065P--rB.....	1228
208L-LFBGA-15x15B-08P--rA.....	1229
225L-LFBGA-13x13B-08P--rB.....	1230
292L-LFBGA-17x17B-08P--rA.....	1231
324L-LFBGA-15x15B-08P--rB.....	1232

#### LGA

45L-LGA-KLR3012-SiP-rD .....	1234
45L-LGA-KLR83012-SiP-rD .....	1235

#### LQFP

208L-LQFP-28x28B-05P--rC.....	1238
64L-LQFP-7x7B-04P-rC .....	1239

#### MQFP

100L-MQFP-14x20B-065P--rC.....	1242
128L-MQFP-14x20B-05P--rE .....	1243

---



---

## Package Index

---



---

### PLCC

28L-PLCC-rC.....	1246
------------------	------

### QFN

24L-QFN2504-4x4B-rC--1of2.....	1248
28L-QFN-3104-5x5mm-rA.....	1250
28L-QFN-3106-5x5mm-rG.....	1251
32L-QFN3304-5x5B-05P-rH--1of2.....	1252
36L-QFN-4106-6x6B-05P-rB--1of2.....	1254
36L-QFN3704-6x6B-05P-rA.....	1256
36L-QFN3706-6x6B-05P-rA.....	1257
40L-QFN-4104-6x6B-05P-rB--1of2.....	1258
40L-QFN-4304-6x6B-05P-rE--1of2.....	1260
48L-QFN4104-7x7B-rG--1of2.....	1262
48L-QFN5304-7x7B-rB--1of2.....	1264
56L-QFN4304-8x8B-rE--1of2.....	1266
56L-QFN5904-8x8B-rF--1of2.....	1268
64L-QFN4704-9x9B-rC--1of2.....	1270
64L-QFN6004-9x9B-rB--1of2.....	1272
64L-QFN7304-9x9B-rC--1of2.....	1274
72L-QFN6004-10x10B-rC--1of2.....	1276
72L-QFN7904-10x10B-rA.....	1278

### SQFN

12L-SQFN-4x4B-08P-rC.....	1280
16L-SQFN-4x4B-065P-rC.....	1281
16L-SQFN3-3x3B-05P-rB.....	1282
16L-SQFN5-5x5B-08P-rB.....	1283
20L-SQFN-4x4B-05P-rF.....	1284
24L-S4QFN-4x4B-05P-rA.....	1285
24L-SQFN-5x5B-065P-rB.....	1286
28L-SQFN-3104--5x5B-05P-rA.....	1287
28L-SQFN-3106--5x5B-05P-rA.....	1288
32L-SQFN-5x5B-05P-rB.....	1289
36L-SQFN-3706-6x6B-05P-rB.....	1290
48L-SQFN-4104-7x7B-05P--rB.....	1291
48L-SQFN-5304-7x7B-05P--rA.....	1292

---



---

## Package Index

---



---

### **QFP**

100L-QFP-14x20B-065P--rC.....	1294
128L-QFP-14x20B-05P--rE.....	1295
160L-QFP-28x28B-065P--rA.....	1296
208L-QFP-28x28B-05P--rC.....	1297

### **SIP**

20L-SIP-R-rB.....	1300
-------------------	------

### **QLEX**

10L-S18QLeX-1800x1300x550B-400P--rB.....	1302
10L-S21QLeX-2100x1600x550B-500P--rB.....	1303

### **SOT-23**

SOT23-FAMILY-rD.....	1306
----------------------	------

### **SOIC**

14L-SOIC-150 mils-wide-rB.....	1308
8L-SOIC-150 mils-wide-body-rB.....	1309

### **SSOP**

SSOP-150mils-WIDE-FAMILY-rC.....	1312
----------------------------------	------

### **TDFN**

8L-TDFN-151704-type1-2x3B-05P-rA.....	1314
---------------------------------------	------

### **TFBGA**

129L-TFBGA-7x7B-05P--rC.....	1316
134L-TFBGA-7x7B-05P--rB.....	1317
144L-TFBGA-7x7B-05P--rD.....	1318

### **TSSOP**

TSSOP-3x3B-FAMILY-rB.....	1320
---------------------------	------

### **TQFP**

100L-TQFP-14x14B-05P--rC.....	1322
176L-TQFP-20x20x1p4B-04P--rA.....	1323
AP-TQFP-1p4THICK-SQUARE-rC.....	1324

### **UFBGA**

25L-UFBGA-3x3B-05P-rA.....	1326
----------------------------	------

---



---

## Package Index

---



---

### VFBGA

25L-VFBGA-3x3B-05P--rB .....	1328
40L-VFBGA-4x4B-05P-rA.....	1329

### WFBGA

49L-WFBGA-3500x3500umB-400umP--rA .....	1332
---	------

### VTQFP

100L-VTQFP-14x14B-05P--rC .....	1334
128L-VTQFP-14x14B-04P--rC .....	1335
144L-VTQFP-20x20x1B-05P--rA.....	1336

### XVTQFP

128L-XVTQFP-14x14B-05P-5x5ePAD--rA.....	1338
---	------

## LEGACY SUPERTEX PACKAGE DRAWINGS & SPECIFICATIONS

### BCC

B1_26_BCCx.....	1342
DSPD-84BCC_B2 .....	1343

### BD

BD_42-Ball Bumped Package Outline (BD) 5.29x5.30 mm Body .....	1346
--	------

### CERPAC

DJ_44_Cerpacx.....	1348
--------------------	------

### DFN

DSPD-10DFNK73X3P050.....	1350
DSPD-19DFNK77X5P050.....	1351
K6_08_DFN_4x4_P100x.....	1352
K6_08_DFN_5x5_P127x.....	1353
K6_10_DFN_3x4_P050x.....	1354
K6_12_DFN_4x4_P050x.....	1355
K6_18_DFN_5x5_P050x.....	1356
K7_08_DFN_3x3_P065x.....	1357
K7_10_DFN_3x3_P050x.....	1358
K7_10_DFN_4x4_P065x.....	1359

### LLGA

G1_26_LLGAx.....	1362
------------------	------

---



---

## Package Index

---



---

### LFGA

LA_06_LFGAx.....	1364
LA_22_LFGAx.....	1365
LA_64_LFGAx.....	1366
LB_64_LFGAx.....	1367

### LQFP

FG_032_LQFPx.....	1370
FG_048_LQFPx.....	1371

### MQFP

FG_100_MQFPx.....	1374
-------------------	------

### MSOP

MG_08_MSOPx.....	1376
MG_10_MSOPx.....	1377

### PDIP

P_14_PDIPx.....	1380
P_16_PDIPx.....	1381
P_28_PDIPx.....	1382
P_40_PDIPx.....	1383

### PLCC

PJ_28_PLCC.....	1386
PJ_44_PLCC.....	1387

### PQFP

PG_044_PQFPx.....	1390
PG_064_PQFP.....	1391
PG_080_PQFP.....	1392
PG_100_PQFP.....	1393

### QFN

K6_16_QFN_4x4_P065x.....	1396
DSPD-24QFNK64X4P050.....	1397
K6_12_QFN_4x4_P080x.....	1398
K6_14_QFN_5x5_P127x.....	1399
K6_16_QFN_3x3_P050x.....	1400
K6_16_QFN_4x4_P065x.....	1401
K6_24_QFN_4x5_P050x.....	1402
K6_32_QFN_5x5_P050x.....	1403
K6_32_QFN_5x5_P050x.....	1403



---



---

## Package Index

---



---

K6_33_QFN_6x6_P050x.....	1404
K6_40_QFN_6x6_P050x.....	1405
K6_48_QFN_7x7_P050x.....	1406
K6_56_QFN_8x8_P050x.....	1407
K6_64_QFN_9x9_P050x.....	1408
K6_80_QFN_11x11_P050x.....	1409
K7_12_QFN_3x3_P050x.....	1410
K7_16_QFN_3x3_P050x.....	1411
K7_32_QFN_5x5_P050x.....	1412
K7_32_QFN_6x6_P050x.....	1413
K7_40_QFN_5x5_P040x.....	1414
K7_44_QFN_7x7_P050x.....	1415

### QSOP

QP_44_QSOPx.....	1418
------------------	------

### SOIC

SG_08_SOICx.....	1420
LG_TG_08_SOICx.....	1421
NG_14_SOICx.....	1422
NG_16_SOICx.....	1423
NG_16_SOICV1x.....	1424

### SOT-23

K1_03_TO236ABx.....	1426
K1_05_SOT23x.....	1427

### SOT-223

K5_03_SOT223x.....	1430
--------------------	------

### SOW

DSPD-16SOWSG.....	1432
WG_16_SOWx.....	1433
WG_20_SOWx.....	1434
WG_24_SOWx.....	1435
WG_28_SOWx.....	1436

### TO-39

N2_03_TO39x.....	1438
------------------	------

### TO-92

DSPD-3TO92N3.....	1440
L_LL_N3_3_TO92x.....	1441

---



---

## Package Index

---



---

### TO-220

N5_03_TO220x .....	1444
K2_07_TO220x .....	1445

### TO-243

N8_03_TO243AAx .....	1448
----------------------	------

### TO-252

K4_03_TO252_DPAKx.....	1450
------------------------	------

### TQFP

HF_128_TQFPx .....	1452
--------------------	------

### TSSOP

TS_24_TSSOPx.....	1454
-------------------	------

## LEGACY MICREL PACKAGE DRAWINGS & SPECIFICATIONS

### CDFN

CDFN5032-4LD-PL-1-A .....	1458
CDFN3225-4LD-PL-1-A .....	1459
CDFN2520-4LD-PL-1-A .....	1460
CDFN75-6LD-PL-1-A.....	1461
CDFN2520-6LD-PL-1-A .....	1462
CDFN3225-6LD-PL-1-A .....	1463
CDFN5032-6LD-PL-1-A .....	1464

### CERQUAD

CERQUAD-32LD-PL-1-A 1.....	1466
CERQUAD-32LD-PL-1-A 2.....	1467

### CERSIP

C04-1189a_6L_CERSiP_7x5x1-62mm_AC 1 .....	1470
5X7PKG_VA9501_0318-2 1.....	1472

### CLLCC

CLLCC75-6LD-PL-1-A.....	1476
-------------------------	------

### CQFN

CQFN33-16LD-PL-1-B 1 .....	1478
CQFN33-16LD-PL-1-B 2 .....	1479
CQFN2528-17LD-PL-1-A .....	1480



## Package Index

### CTDFN

CTDFN22-8LD-PL-1-A .....	1482
CTDFN22-10LD-PL-1-A .....	1483

### CTQFN

CTQFN33-20LD-PL-1-A .....	1486
---------------------------	------

### DFN

DFN75-4LD-PL-1-A .....	1488
DFN1216-4LD-PL-1-B .....	1489
DFN1216-4LD-PL-1-C 1 .....	1490
DFN1216-4LD-PL-1-C 2 .....	1491
DFN22-6LD-PL-1-B .....	1492
DFN1616-6LD-PL-1-A .....	1493
DFN1616-6LD-PL-1-B 1 .....	1494
DFN1616-6LD-PL-1-B 2 .....	1495
DFN22-8LD-PL-1-B .....	1496
DFN22-8LD-PL-1-C 1 .....	1497
DFN22-8LD-PL-1-C 2 .....	1498
DFN22-8LD-PL-8-A .....	1499
DFN22-8LD-PL-8-B 1 .....	1500
DFN22-8LD-PL-8-B 2 .....	1501
DFN33-8LD-PL-1-B 1 .....	1502
DFN33-8LD-PL-1-B 2 .....	1503
DFN44-8LD-PL-1-B 1 .....	1504
DFN44-8LD-PL-1-B 2 .....	1505
DFN44-8LD-PL-2-B 1 .....	1506
DFN44-8LD-PL-2-B 2 .....	1507
DFN33-10LD-PL-1-B 1 .....	1508
DFN33-10LD-PL-1-B 2 .....	1509
DFN2525-10LD-PL-1-A .....	1510
DFN33-10LD-PL-2-A .....	1511
DFN33-10LD-PL-2-B 1 .....	1512
DFN33-10LD-PL-2-B 2 .....	1513
DFN33-12LD-PL-1-C 1 .....	1514
DFN33-12LD-PL-1-C 2 .....	1515
DFN35-20LD-PL-1-A 1 .....	1516
DFN35-20LD-PL-1-A 2 .....	1517
DFN44-12LD-PL-1-B 1 .....	1518
DFN44-12LD-PL-1-B 2 .....	1519
DFN45-20LD-PL-1-B 1 .....	1520
DFN45-20LD-PL-1-B 2 .....	1521



---



---

## Package Index

---



---

### FBGA

FBGA5555-85LD-PL-1-A 1 ..... 1524

### FDFN

FDFN1212-4LD-PL-1-C 1 ..... 1526

FDFN1212-4LD-PL-1-C 2 ..... 1527

FDFN34-10LD-PL-9-A 1 ..... 1528

FDFN43-10LD-PL-1-B 1 ..... 1529

FDFN43-10LD-PL-1-B 2 ..... 1530

### QFN

QFN1220-10LD-PL-1-B 1 ..... 1532

QFN1220-10LD-PL-1-B 2 ..... 1533

QFN33-16LD-PL-1-A 1 ..... 1534

QFN33-20LD-PL-1-A 1 ..... 1535

QFN3535-20LD-PL-1-B 1 ..... 1536

QFN3535-20LD-PL-1-B 2 ..... 1537

QFN34-20LD-PL-1-A 1 ..... 1538

QFN33-24LD-PL-1-A 1 ..... 1539

QFN34-24LD-PL-1-A 1 ..... 1540

QFN34-24LD-PL-2-E 1 ..... 1541

QFN34-24LD-PL-2-E 2 ..... 1542

QFN44-26LD-PL-1-B 1 ..... 1543

QFN44-26LD-PL-1-B 2 ..... 1544

QFN44-28LD-PL-1-B 1 ..... 1545

QFN44-28LD-PL-1-B 2 ..... 1546

QFN55-28LD-PL-1-B 1 ..... 1547

QFN55-28LD-PL-1-B 2 ..... 1548

QFN35-29LD-PL-1-B 1 ..... 1549

QFN35-29LD-PL-1-B 2 ..... 1550

QFN55-32LD-PL-1-B 1 ..... 1551

QFN55-32LD-PL-1-B 2 ..... 1552

QFN46-34LD-PL-1-A 1 ..... 1553

QFN46-34LD-PL-1-A 2 ..... 1554

QFN46-34LD-PL-2-B 1 ..... 1555

QFN46-34LD-PL-2-B 2 ..... 1556

QFN4545-36LD-PL-1-B 1 ..... 1557

QFN4545-36LD-PL-1-B 2 ..... 1558

QFN55-36LD-PL-1-B 1 ..... 1559

QFN55-36LD-PL-1-B 2 ..... 1560

QFN56-38LD-PL-1-A 1 ..... 1561



---



---

## Package Index

---



---

FQFN56-38LD-PL-1-A 2 .....	1562
FQFN56-38LD-PL-1-A 3 .....	1563

### FTDFN

FTDFN1212-4LD-PL-1-B 1 .....	1566
FTDFN1212-4LD-PL-1-B 2 .....	1567
FTDFN085085-4LD-PL-1-B 1 .....	1568
FTDFN085085-4LD-PL-1-B 2 .....	1569
FTDFN22-6LD-PL-1-A 1 .....	1570
FTDFN22-6LD-PL-1-A 2 .....	1571

### FTQFN

FTQFN1010-6LD-PL-1-B 1 .....	1574
FTQFN1010-6LD-PL-1-B 2 .....	1575
FTQFN1212-6LD-PL-1-B 1 .....	1576
FTQFN1212-6LD-PL-1-B 2 .....	1577
FTQFN22-8LD-PL-1-A 1 .....	1578
FTQFN22-8LD-PL-1-A 2 .....	1579
FTQFN22-12LD-PL-1-B 1 .....	1580
FTQFN22-12LD-PL-1-B 2 .....	1581
FTQFN1620-12LD-PL-1-B 1 .....	1582
FTQFN1620-12LD-PL-1-B 2 .....	1583
FTQFN2525-14LD-PL-1-B 1 .....	1584
FTQFN2525-14LD-PL-1-B 2 .....	1585
FTQFN22-16LD-PL-1-B 1 .....	1586
FTQFN22-16LD-PL-1-B 2 .....	1587
FTQFN2025-16LD-PL-1-B 1 .....	1588
FTQFN2025-16LD-PL-1-B 2 .....	1589
FTQFN2525-16LD-PL-1-A 1 .....	1590
FTQFN2525-16LD-PL-1-A 2 .....	1591
FTQFN33-20LD-PL-1-B 1 .....	1592
FTQFN33-20LD-PL-1-B 2 .....	1593

### GJQFN

GJQFN2530-20LD-PL-1-D 1 .....	1596
GJQFN2530-20LD-PL-1-D 2 .....	1597

### GKQFN

GKQFN2530-20LD-PL-1-D 1 .....	1600
GKQFN2530-20LD-PL-1-D 2 .....	1601

---



---

## Package Index

---



---

### H3QFN

H3QFN88-52LD-PL-1-G 1 .....	1604
H3QFN88-52LD-PL-1-G 2 .....	1605
H3QFN88-52LD-PL-1-G 3 .....	1606
H3QFN88-52LD-PL-2-A 1 .....	1607
H3QFN88-52LD-PL-2-A 2 .....	1608
H3QFN88-52LD-PL-2-A 3 .....	1609
H3QFN88-52LD-PL-3-A 1 .....	1610
H3QFN88-52LD-PL-3-A 2 .....	1611
H3QFN88-52LD-PL-3-A 3 .....	1612
H3QFN1212-64LD-PL-1-D 1 .....	1613
H3QFN1212-64LD-PL-1-D 2 .....	1614
H3QFN1212-64LD-PL-1-D 3 .....	1615

### H4QFN

H4QFN1010-52LD-PL-1-H 1 .....	1618
H4QFN1010-52LD-PL-1-H 2 .....	1619
H4QFN1010-52LD-PL-1-H 3 .....	1620
H4QFN1212-64LD-PL-1-F 1 .....	1621
H4QFN1212-64LD-PL-1-F 2 .....	1622
H4QFN1212-64LD-PL-1-F 3 .....	1623

### HDFN

HDFN33-12LD-PL-1-A 1 .....	1626
HDFN3035-14LD-PL-1-A 1 .....	1627

### HJDFN

HJDFN2520-10LD-PL-1-A 1 .....	1630
HJDFN3035-14LD-PL-1-C 1 .....	1631
HJDFN3035-14LD-PL-1-C 2 .....	1632

### HKQFN

HKQFN46-34LD-PL-1-A 1 .....	1634
-----------------------------	------

### HQFN

HQFN46-28LD-PL-1-A 1 .....	1636
----------------------------	------

### LDFN

LDFN32-14LD-PL-1-A .....	1638
--------------------------	------

### LFBGA

LFBGA9x9-100LD-PL-1-A .....	1640
LFBGA10x10-100LD-PL-1-A .....	1641

---



---

## Package Index

---



---

### LGA

LGA5032-6LD-PL-1-A .....	1644
LGA75-6LD-PL-1-B .....	1645
LGA75-38LD-PL-1-D .....	1646
LGA5555-76LD-PL-1-A .....	1647

### LQFN

LQFN33-16LD-PL-1-A 1 .....	1650
LQFN33-16LD-PL-1-A 2 .....	1651

### LQFP

LQFP10x10-445264LD-PL-1-A 1 .....	1654
LQFP10x10-445264LD-PL-1-A 2 .....	1655
LQFP10x10-445264LD-PL-1-A 3 .....	1656
LQFP7x7-48LD-PL-1-A .....	1657
LQFP7x7-48LD-PL-5-A .....	1658
LQFP7x7-64LD-PL-817-A .....	1659
LQFP10x10-64LD-PL-1-A .....	1660
LQFPEP10X10-64LD-PL-1-A .....	1661
LQFP10x10-80LD-PL-1-A .....	1662
LQFP12x12-100LD-PL-86-A .....	1663
LQFP14x14-128LD-PL-1-A .....	1664
LQFP20x20-176LD-PL-1-A .....	1665

### MSOP

MSOP-8LD-PL-1-A .....	1668
MSOPEP-8LD-PL-1-A .....	1669
MSOP-10LD-PL-1-A .....	1670
MSOPEP-10LD-PL-1-A .....	1671

### P2QFN

P2QFN106-54LD-PL-1-A .....	1674
----------------------------	------

### PBGA

PBGA19x19-289LD-PL-1-A .....	1676
PBGA27x27-400LD-PL-1-A .....	1677

### PDIP

PDIP-300mil-PL-1-A .....	1680
PDIP-300mil-PL-1-B .....	1681
PDIP-8LD-PL-1-A .....	1682
PDIP-14LD-PL-1-A .....	1683
PDIP-16LD-PL-1-A .....	1684

---



---

## Package Index

---



---

PDIP-18LD-PL-1-A .....	1685
PDIP-20LD-PL-1-A .....	1686
PDIP-22LD-PL-1-A .....	1687
PDIP-28LD-PL-1-A .....	1688
PDIP-40LD-PL-1-A .....	1689
PDIP-300mil-PL-1-A .....	1690
PDIP-300mil-PL-1-B .....	1691

### PKQFN

---

PKQFN106-54LD-PL-1-C .....	1694
----------------------------	------

### PLCC

---

PLCC-20LD-PL-1-A .....	1696
PLCC-28LD-PL-1-A .....	1697
PLCC-44LD-PL-1-A .....	1698

### PQFP

---

PQFP14x20-128LD-PL-1-A .....	1700
PQFP28x28-208LD-PL-1-A .....	1701

### QFN

---

QFN22-10LD-PL-1-A .....	1704
QFN2525-14LD-PL-1-A .....	1705
QFN2532-14LD-PL-1-A .....	1706
QFN33-16L_Greatek .....	1707
QFN33-16LD-PL-1-B 1 .....	1708
QFN33-16LD-PL-1-B 2 .....	1709
QFN33-16LD-PL-2-A .....	1710
QFN33-16LD-PL-3-A .....	1711
QFN3035-16LD-PL-1-A .....	1712
QFN44-16LD-PL-1-A .....	1713
QFN44-16LD-PL-2-A .....	1714
QFN55-16LD-PL-1-A .....	1715
QFN34-20LD-PL-1-A_ .....	1716
QFN34-20LD-PL-2-A .....	1717
QFN5032-20LD-PL-1-B .....	1718
QFN44-24LD-PL-1-B .....	1719
QFN35-26LD-PL-1-B 1 .....	1720
QFN35-26LD-PL-1-B 2 .....	1721
QFN44-28LD-PL-1-A .....	1722
QFN45-28LD-PL-1-A .....	1723
QFN56-28LD-PL-1-B .....	1724
QFN56-28LD-PL-2-A .....	1725



---



---

## Package Index

---



---

QFN56-30LD-PL-1-A 1 .....	1726
QFN56-30LD-PL-1-A 2 .....	1727
QFN44-32LD-PL-1-A .....	1728
QFN55-32LD-PL-1-B .....	1729
QFN55-32LD-PL-2-A .....	1730
QFN55-32LD-PL-5-B .....	1731
QFN66-40LD-PL-1-A 1 .....	1732
QFN66-40LD-PL-1-A 2 .....	1733
QFN77-44LD-PL-1-B .....	1734
QFN77-48LD-PL-1-C 1 .....	1735
QFN77-48LD-PL-1-C 2 .....	1736
QFN77-48LD-PL-2-B .....	1737
QFN88-56LD-PL-1-A .....	1738
QFN88-64LD-PL-1-A .....	1739
QFN88-64LD-PL-2-A .....	1740
QFN99-64LD-PL-1-A .....	1741
QFN88-68LD-PL-86-A .....	1742
QFN1010-72LD-PL-1-A .....	1743
QFN77-84LD-PL-1-D .....	1744

### QSOP

---

QSOP-16LD-PL-1-A .....	1746
QSOPEP-16LD-PL-1-A .....	1747
QSOP-20LD-PL-1-A .....	1748

### SC70

---

SC70-3LD-PL-1-A .....	1750
SC70-4LD-PL-1-A .....	1751
SC70-5LD-PL-1-A .....	1752
SC70-5LD-PL-2-B .....	1753
SC70-6LD-PL-1-A .....	1754

### SOIC

---

SOICN-8LD-PL-1-A .....	1756
SOICNEP-8LD-PL-1-A .....	1757
SOICN-14LD-PL-1-A .....	1758
SOICN-16LD-PL-1-A .....	1759
SOICW-16LD-PL-1-A .....	1760
SOICW-18LD-PL-1-A .....	1761
SOICW-20LD-PL-1-A .....	1762
SOICW-24LD-PL-1-A .....	1763
SOICW-28LD-PL-1-A .....	1764
SOICWEP-28LD-PL-1-A .....	1765

---



---

## Package Index

---



---

### SOT

SOT23-3LD-PL-1-A.....	1768
SOT23-5LD-PL-1-A.....	1769
SOT23-6LD-PL-1-A.....	1770
SOT23-8LD-PL-1-A.....	1771
SOT143-4LD-PL-1-A.....	1772
SOT223-3LD-PL-1-A.....	1773

### SPAK

SPAK-3LD-PL-1-A.....	1776
SPAK-5LD-PL-1-A.....	1777
SPAK-7LD-PL-1-A.....	1778

### SSOP

SSOP-16LD-PL-1-A.....	1780
SSOP-20LD-PL-1-A.....	1781
SSOP-24LD-PL-1-A.....	1782
SSOP-28LD-PL-1-A.....	1783
SSOP-48LD-PL-1-A.....	1784

### TDFN

TDFN22-6LD-PL-1-A.....	1786
TDFN22-6LD-PL-2-A.....	1787
TDFN22-8LD-PL-1-A.....	1788
TDFN22-10LD-PL-1-A.....	1789
TDFN1010-4LD-PL-2-B.....	1790
TDFN1212-4LD-PL-1-A.....	1791
TDFN1212-6LD-PL-1-C.....	1792
TDFN1216-4LD-PL-1-B.....	1793
TDFN1612-8LD-PL-1-C.....	1794
TDFN1616-6LD-PL-1-A.....	1795
TDFN2013-6LD-PL-1-D 1.....	1796
TDFN2013-6LD-PL-1-D 2.....	1797
TDFN2525-10LD-PL-1-C.....	1798
TDFN2525-12LD-PL-1-A.....	1799

### TO220-TO263

TO220-3LD-PL-1-B.....	1802
TO220-5LD-PL-1-B.....	1803
TO220-LB02-5LD-PL-1-A.....	1804
TO220-LB03-5LD-PL-1-A.....	1805
TO247-3LD-PL-1-A.....	1806

---



---

## Package Index

---



---

TO247-5LD-PL-1-A.....	1807
TO252-2LD-PL-1-A.....	1808
TO252-3LD-PL-1-A.....	1809
TO252-5LD-PL-1-A.....	1810
TO263-3LD-PL-1-A.....	1811
TO263-5LD-PL-1-A.....	1812
TO263-7LD-PL-1-A.....	1813

### TQFN

---

TQFN1212-8LD-PL-1-A.....	1816
TQFN1616-12LD-PL-1-A 1.....	1817
TQFN1616-12LD-PL-1-A 2.....	1818
TQFN2525-14LD-PL-1-A.....	1819
TQFN2525-16LD-PL-1-A.....	1820

### TQFP

---

TQFP7x7-32LD-PL-1-B.....	1822
TQFPEP7X7-32LD-PL-1-A.....	1823
TQFPEP7X7-32LD-PL-2-A.....	1824
TQFP7x7-48LD-PL-1-A.....	1825
TQFPEP7X7-48LD-PL-1-A.....	1826
TQFP10x10-64LD-PL-1-A.....	1827
TQFPEP10X10-64LD-PL-1-A.....	1828
TQFPEP14x14-80LD-PL-1-A 1.....	1829
TQFPEP14x14-80LD-PL-1-A 2.....	1830

### TSOT

---

TSOT-5LD-PL-1-A.....	1832
TSOT-6LD-PL-1-A.....	1833

### TSSOP

---

TSSOP-8LD-PL-1-A.....	1836
TSSOP-14LD-PL-1-A.....	1837
TSSOP-16LD-PL-1-A.....	1838
TSSOPEP-1416LD-PL-1-A 1.....	1839
TSSOPEP-1416LD-PL-1-A 2.....	1840
TSSOPEP-1416LD-PL-1-A 3.....	1841
TSSOP-20LD-PL-1-A.....	1842
TSSOPEP-20LD-PL-1-A.....	1843
TSSOP-24LD-PL-1-A.....	1844
TSSOPEP-24LD-PL-1-A.....	1845
TSSOPEP-24LD-PL-2-A.....	1846
TSSOP-28LD-PL-1-A.....	1847



---



---

**Package Index**

---



---

**UTDFN**

UTDFN22-10LD-PL-1-B .....	1850
---------------------------	------

**WLCSP**

WLCSP088088D-4BL-PL-9-A .....	1852
WLCSP1510D-6BL-PL-9-A .....	1853
WLCSP080120D-6BL-PL-9-A .....	1854
WLCSP084132D-6BL-PL-9-A .....	1855
WLCSP211111D-8BL-PL-9-A .....	1856
WLCSP1313Q-9BL-PL-9-A .....	1857
WLCSP167177Q-9BL-PL-9-A .....	1858
WLCSP131171Q-12BL-PL-9-A .....	1859
WLCSP181171Q-16BL-PL-9-A .....	1860
WLCSP188188Q-16BL-PL-9-A .....	1861
WLCSP207226Q-25BL-PL-9-A .....	1862

**WQFN**

WQFN55-32LD-PL-1-A .....	1864
WQFN77-48LD-PL-1-B 1 .....	1865
WQFN77-48LD-PL-1-B 2 .....	1866

**XTDFN**

XTDFN1212-6LD-PL-1-B .....	1868
XTDFN1612-8LD-PL-1-D .....	1869
XTDFN2525-10LD-PL-1-A .....	1870



**MICROCHIP**

---

---

**Package Outlines and Dimensions**

---

---

**NOTES:**

## **Legacy SST Package Drawings & Specifications**



**MICROCHIP**

---

---

**Package Outlines and Dimensions**

---

---

NOTES:

---

---

**Package Outlines and Dimensions**

---

---

**PDIP**

SST Legacy

**Package Outlines and Dimensions**

**32-Lead Plastic Dual Inline Package (PHE/F) - 15.2 mm Body [PDIP]**

**Note:** For the most current package drawings, please see the Microchip Packaging Specification located at <http://www.microchip.com/packaging>

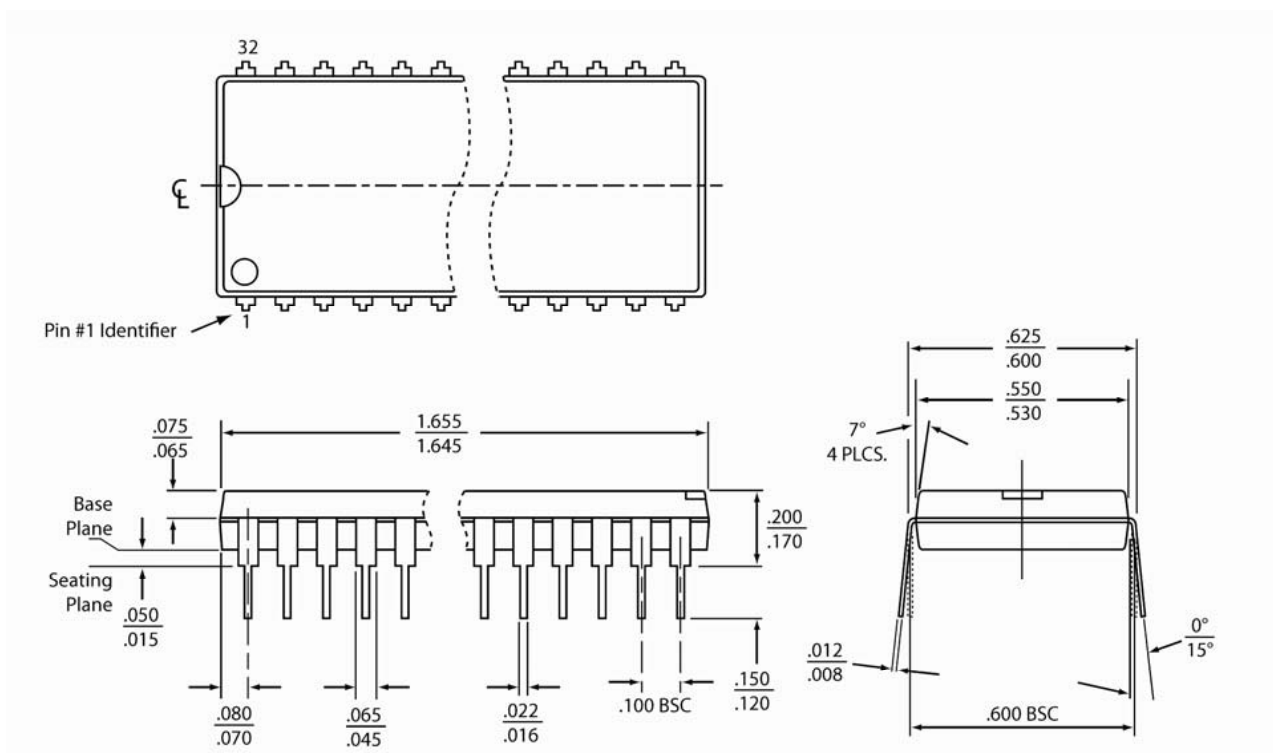

32-pdip-PH-3

**Note:**

1. Complies with JEDEC publication 95 MO-015 AP dimensions, although some dimensions may be more stringent.
2. All linear dimensions are in inches (max/min).
3. Dimensions do not include mold flash. Maximum allowable mold flash is .010 inches

---



---

## Package Outlines and Dimensions

---



---

### 40-Lead Plastic Dual Inline Package (PIE/F) - .600 Inch Body [PDIP]

**Note:** For the most current package drawings, please see the Microchip Packaging Specification located at <http://www.microchip.com/packaging>

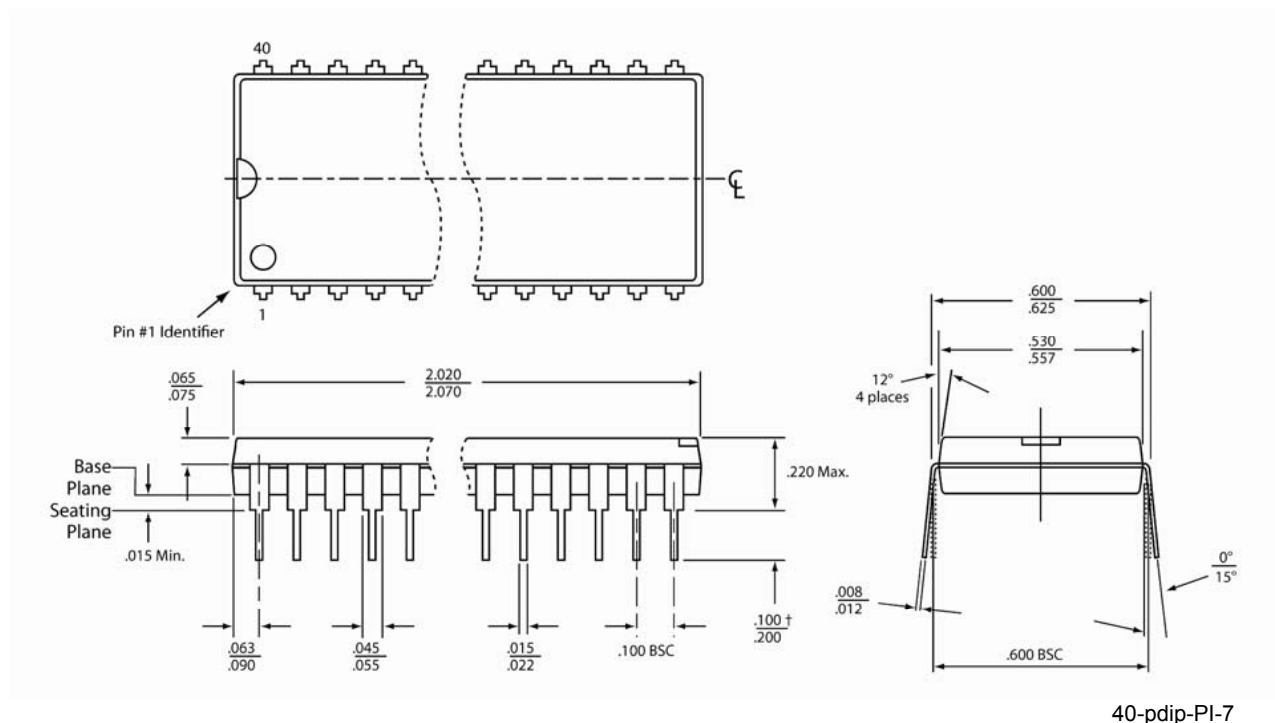

**Note:**

1. Complies with JEDEC publication 95 MS-011 AC dimensions (except as noted), although some dimensions may be more stringent.  
† = JEDEC min is .115; SST min is less stringent
2. All linear dimensions are in inches (min/max).
3. Dimensions do not include mold flash. Maximum allowable mold flash is .010 inches.



**MICROCHIP**

---

---

**Package Outlines and Dimensions**

---

---

**NOTES:**



---

---

**Package Outlines and Dimensions**

---

---

**PLCC**

SST Legacy

**Package Outlines and Dimensions**

**32-Lead Plastic Leadless Chip Carrier (NHE/F) - [PLCC]**

**Note:** For the most current package drawings, please see the Microchip Packaging Specification located at <http://www.microchip.com/packaging>

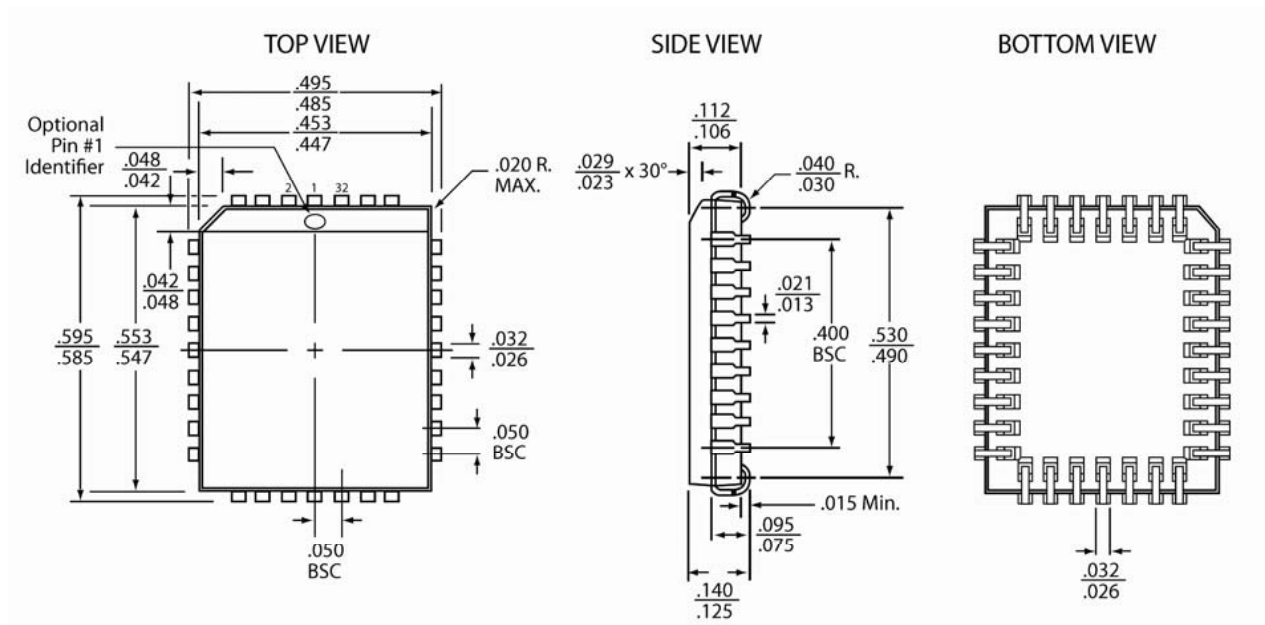

32-plcc-NH-3

**Note:**

1. Complies with JEDEC publication 95 MS-016 AE dimensions, although some dimensions may be more stringent.
2. All linear dimensions are in inches (max/min).
3. Dimensions do not include mold flash. Maximum allowable mold flash is .008 inches.
4. Coplanarity: 4 mils.

---



---

## Package Outlines and Dimensions

---



---

### 44-Lead Plastic Leadless Chip Carrier (NJE/F) - [PLCC]

**Note:** For the most current package drawings, please see the Microchip Packaging Specification located at <http://www.microchip.com/packaging>

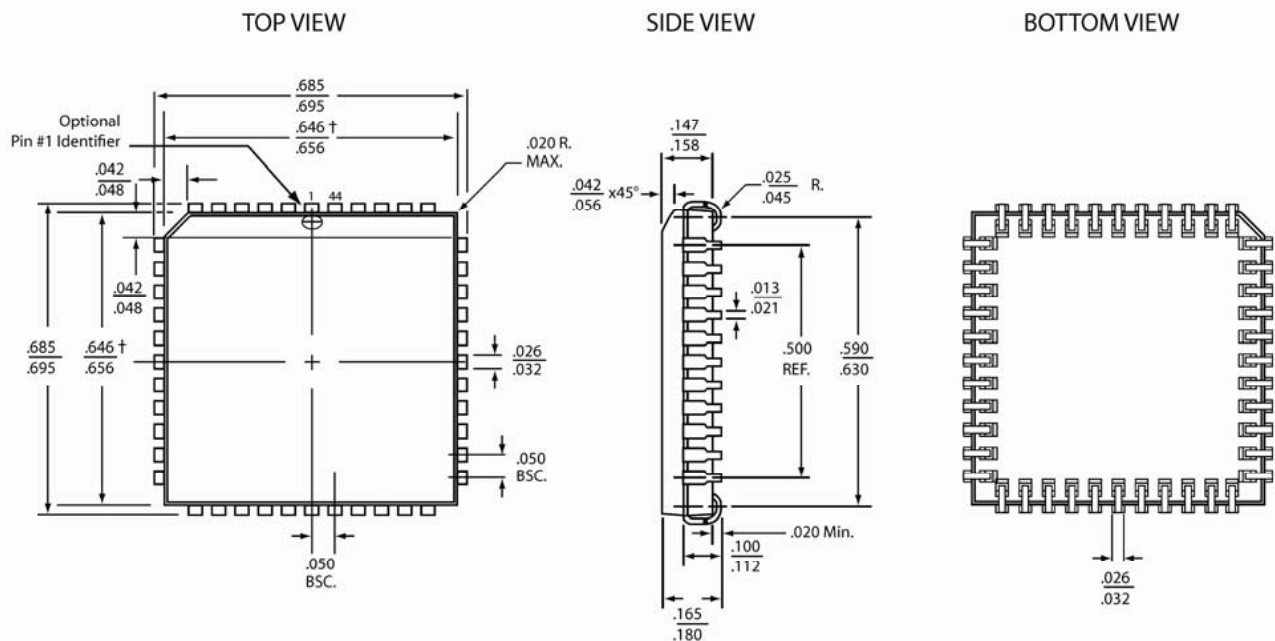

44.PLCC.NJ-ILL.6

**Note:**

1. Complies with JEDEC publication 95 MS-018 AC dimensions (except as noted), although some dimensions may be more stringent.  
† = JEDEC min is .650; SST min is less stringent
2. All linear dimensions are in inches (min/max).
3. Dimensions do not include mold flash. Maximum allowable mold flash is .008 inches.
4. Coplanarity: ± 4 mils.



**MICROCHIP**

---

---

**Package Outlines and Dimensions**

---

---

**NOTES:**

---

---

**Package Outlines and Dimensions**

---

---

**SOIC**

SST Legacy

**Package Outlines and Dimensions**

**8-Lead Small Outline Integrated Circuit (SAE/F) - 5x6 mm Body [SOIC]**

**Note:** For the most current package drawings, please see the Microchip Packaging Specification located at <http://www.microchip.com/packaging>

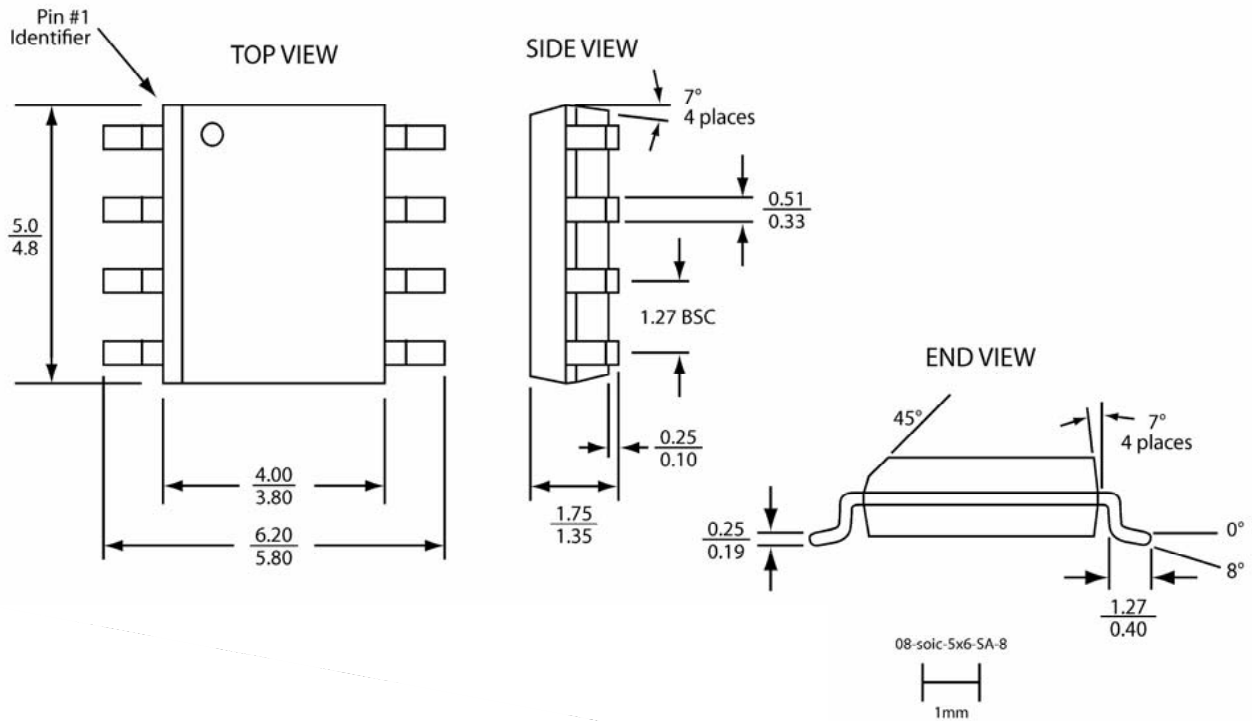

**Note:**

1. Complies with JEDEC publication 95 MS-012 AA dimensions, although some dimensions may be more stringent.
2. All linear dimensions are in millimeters (max/min).
3. Coplanarity: 0.1 mm
4. Maximum allowable mold flash is 0.15 mm at the package ends and 0.25 mm between leads.

## Package Outlines and Dimensions

### 8-Lead Small Outline Integrated Circuit (S3AE/F) - 5x8 mm Body [SOIC]

**Note:** For the most current package drawings, please see the Microchip Packaging Specification located at <http://www.microchip.com/packaging>

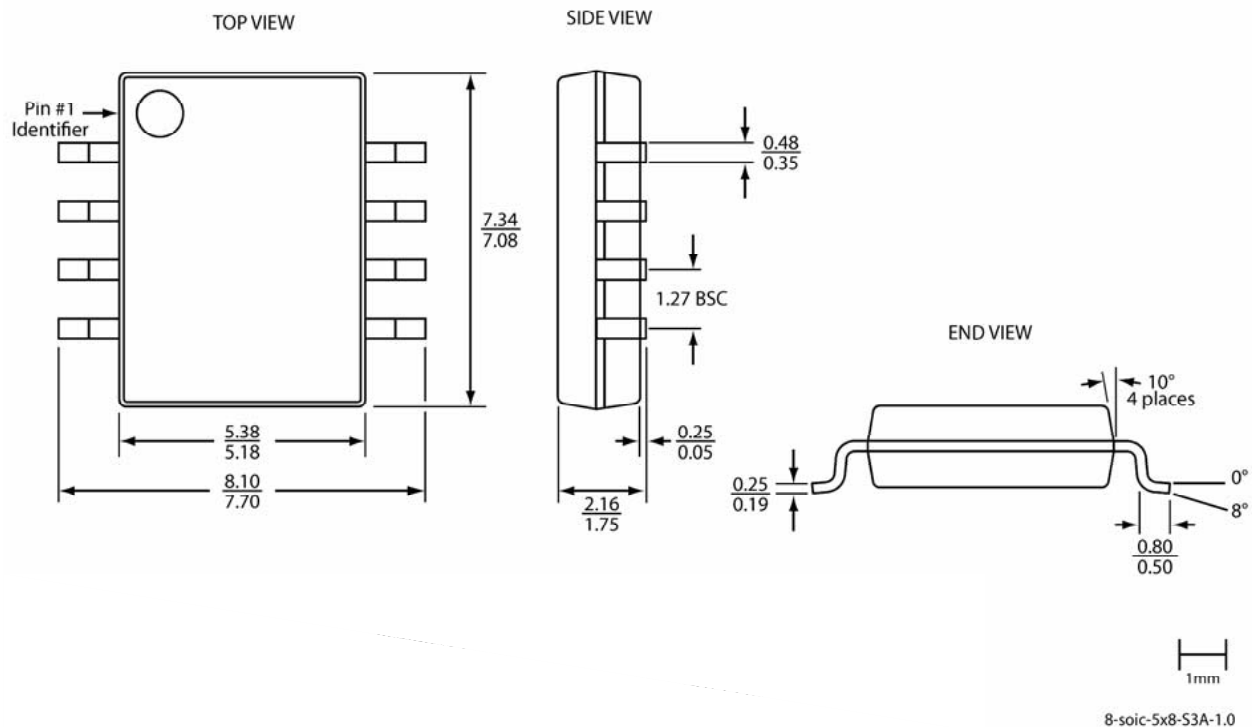

**Note:**

1. All linear dimensions are in millimeters (max/min).
2. Coplanarity: 0.1 mm
3. Maximum allowable mold flash is 0.15 mm at the package ends and 0.25 mm between leads.

**Package Outlines and Dimensions**

**8-Lead Small Outline Integrated Circuit (S2AE/F) - .208 Inch Body [SOIC]**

**Note:** For the most current package drawings, please see the Microchip Packaging Specification located at <http://www.microchip.com/packaging>

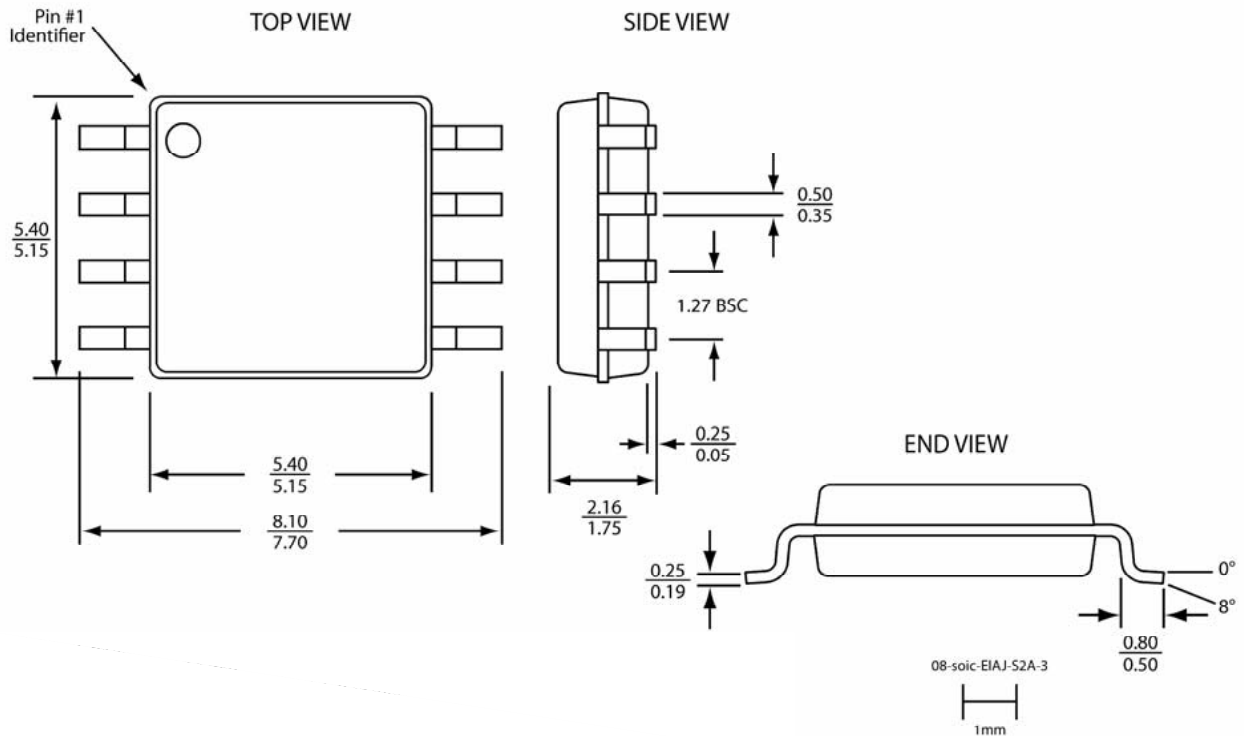

**Note:**

1. All linear dimensions are in millimeters (max/min).
2. Coplanarity: 0.1 mm
3. Maximum allowable mold flash is 0.15 mm at the package ends and 0.25 mm between leads.



---



---

## Package Outlines and Dimensions

---



---

### 16-Lead Small Outline Integrated Circuit (SCE/F) - 7.5 mm Body [SOIC]

**Note:** For the most current package drawings, please see the Microchip Packaging Specification located at <http://www.microchip.com/packaging>

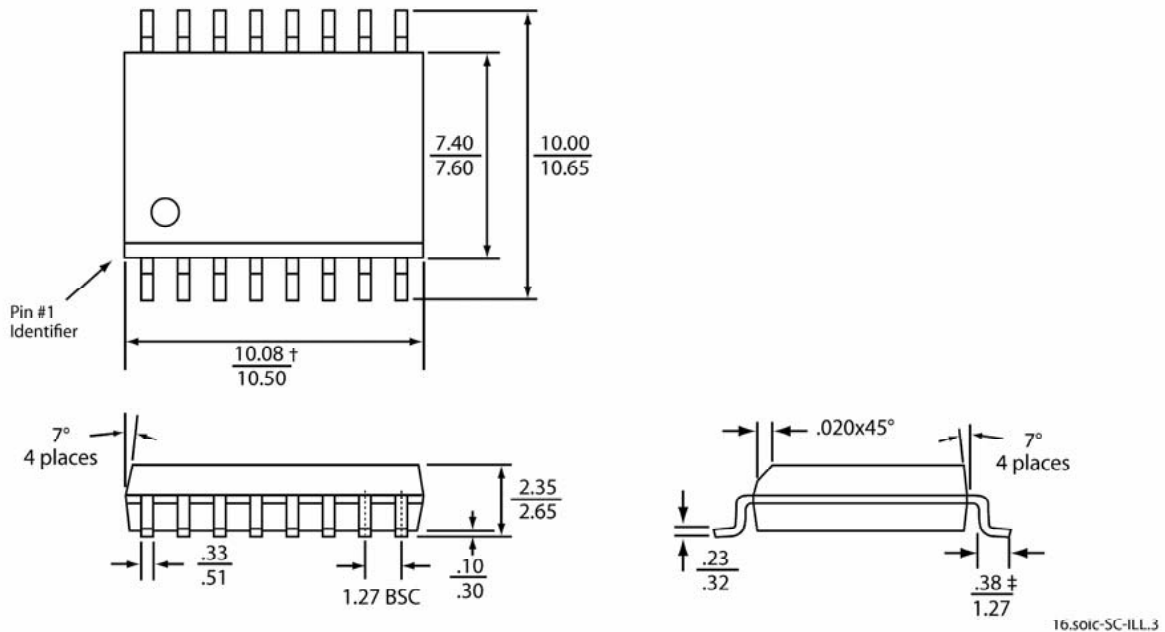

**Note:**

- Complies with JEDEC publication 95 MS-013 AA dimensions (except as noted), although some dimensions may be more stringent.  
 $\dagger$  = JEDEC min is 10.10; SST min (10.08) is less stringent  
 $\ddagger$  = JEDEC min is 0.40; SST min (0.38) is less stringent
- All linear dimensions are in metric (min/max).
- Coplanarity: 0.1 ( $\pm 0.05$ ) mm.
- Maximum allowable mold flash is 0.15mm at the package ends, and 0.25mm between leads.



**MICROCHIP**

---

---

**Package Outlines and Dimensions**

---

---

NOTES:

---

---

**Package Outlines and Dimensions**

---

---

**TBGA**

SST Legacy

**Package Outlines and Dimensions**

**24-Lead Thin Ball Grid Array (T4DE/F) - 6x8 mm Body [TBGA]**

**Note:** For the most current package drawings, please see the Microchip Packaging Specification located at <http://www.microchip.com/packaging>

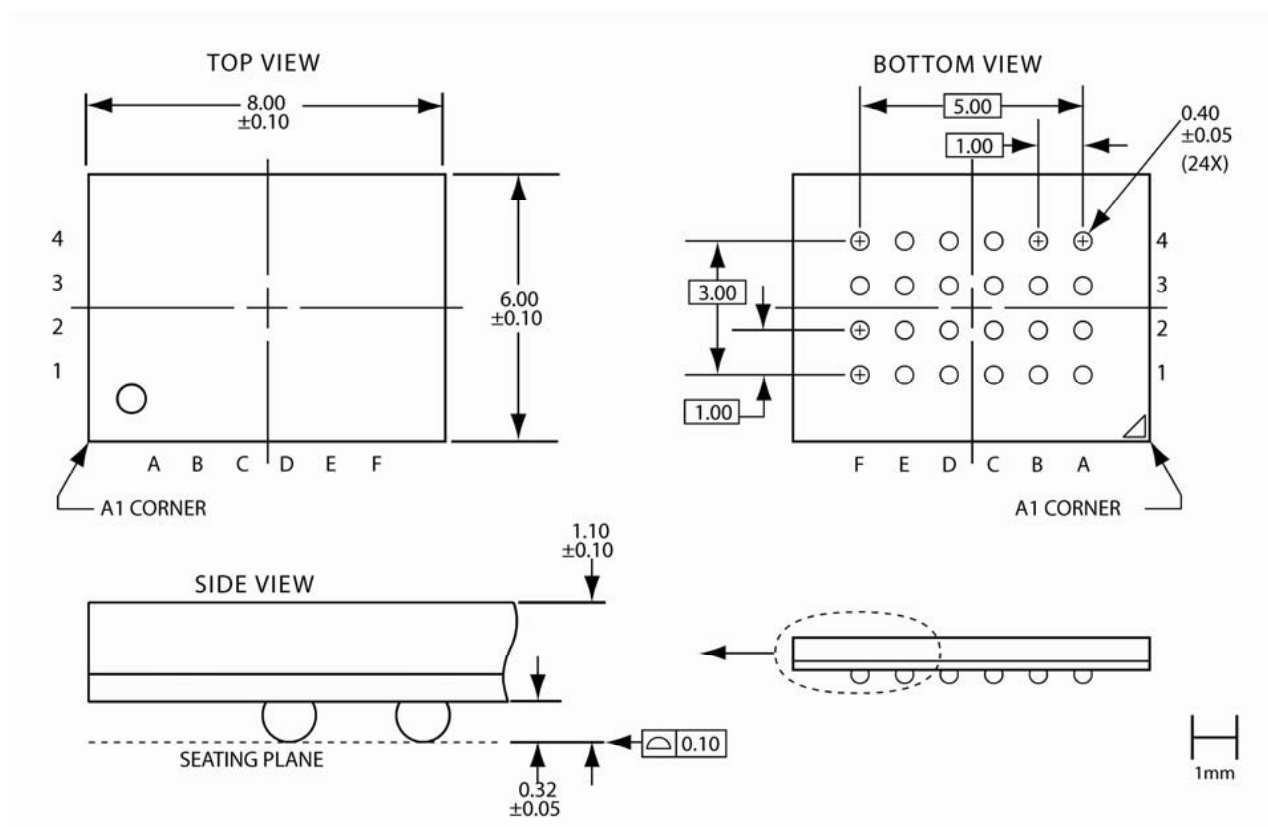

24-tbga-T4D-6x8-1.0

**Note:**

1. Topside A1 indicator is laser engraved.
2. All linear dimensions are in millimeters.
3. Coplanarity: 0.10 mm
4. Ball opening size is 0.32mm ( $\pm 0.05$  mm)

---

---

**Package Outlines and Dimensions**

---

---

**TFBGA**

SST Legacy

**Package Outlines and Dimensions**

**48-Lead Thin Fine-Pitch Ball Grid Array (B3KE/F) - 6x8 mm Body [TFBGA]**

**Note:** For the most current package drawings, please see the Microchip Packaging Specification located at <http://www.microchip.com/packaging>

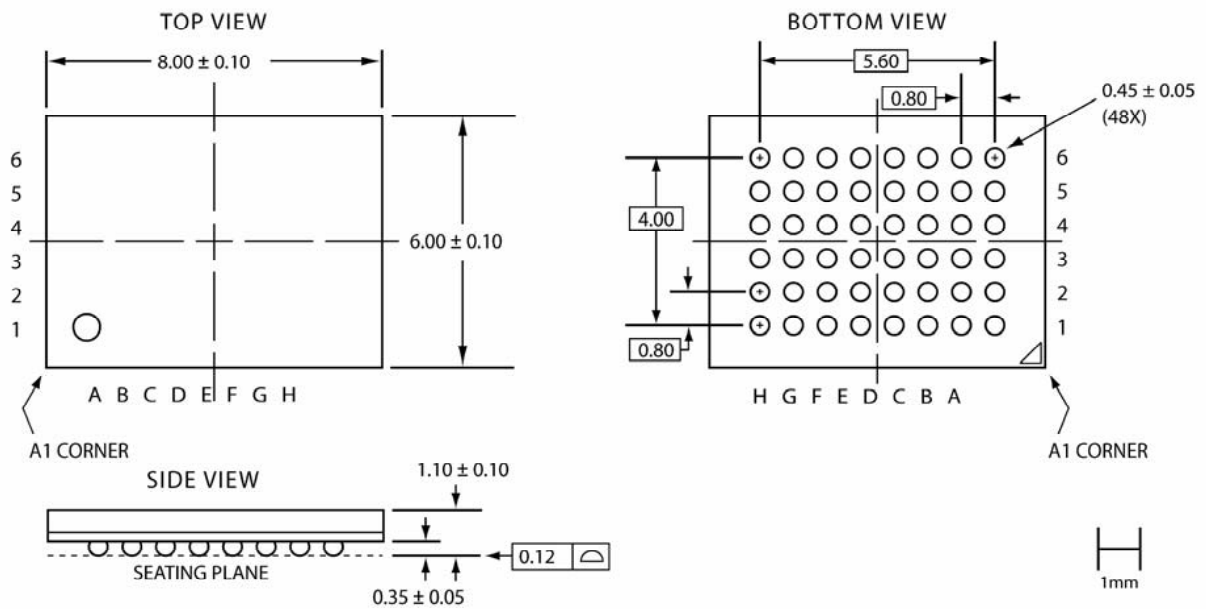

48-tfbga-B3K-6x8-450mic-5

**Note:**

1. Complies with JEDEC Publication 95, MO-210, variant 'AB-1', although some dimensions may be more stringent.
2. All linear dimensions are in millimeters.
3. Coplanarity: 0.12 mm
4. Ball opening size is 0.38 mm ( $\pm 0.05$  mm)

**Package Outlines and Dimensions**

**48-Lead Thin Fine-Pitch Ball Grid Array (B1KE/F) - 8x10 mm Body [TFBGA]**

**Note:** For the most current package drawings, please see the Microchip Packaging Specification located at <http://www.microchip.com/packaging>

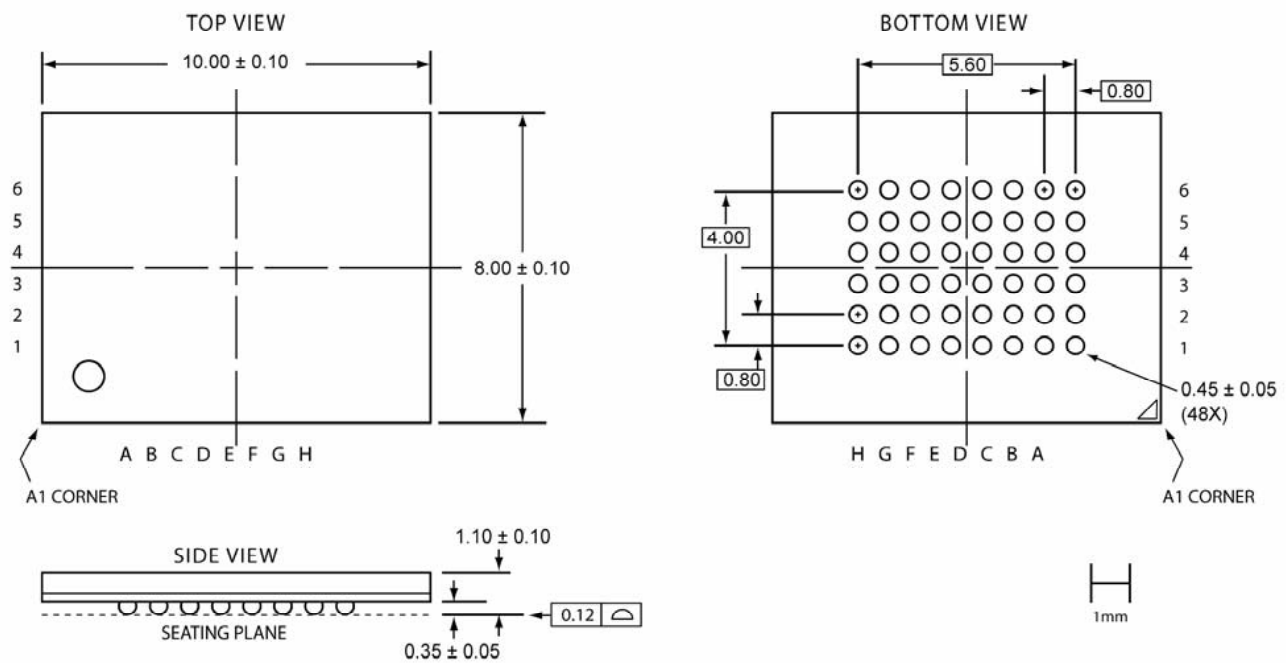

48-tfbga-B1K-8x10-450mic-5

**Note:**

1. Although many dimensions are similar to those of JEDEC Publication 95, MO-210, this specific package is not registered.
2. All linear dimensions are in millimeters.
3. Coplanarity: 0.12 mm
4. Ball opening size is 0.38 mm ( $\pm 0.05$  mm)



**MICROCHIP**

---

---

**Package Outlines and Dimensions**

---

---

NOTES:



---

---

**Package Outlines and Dimensions**

---

---

**WFBGA**  
SST Legacy

**Package Outlines and Dimensions**

**34-Lead Very, Very Thin Fine-Pitch Ball Grid Array (MME/F) - 4x6 mm Body [WFBGA]**

**Note:** For the most current package drawings, please see the Microchip Packaging Specification located at <http://www.microchip.com/packaging>

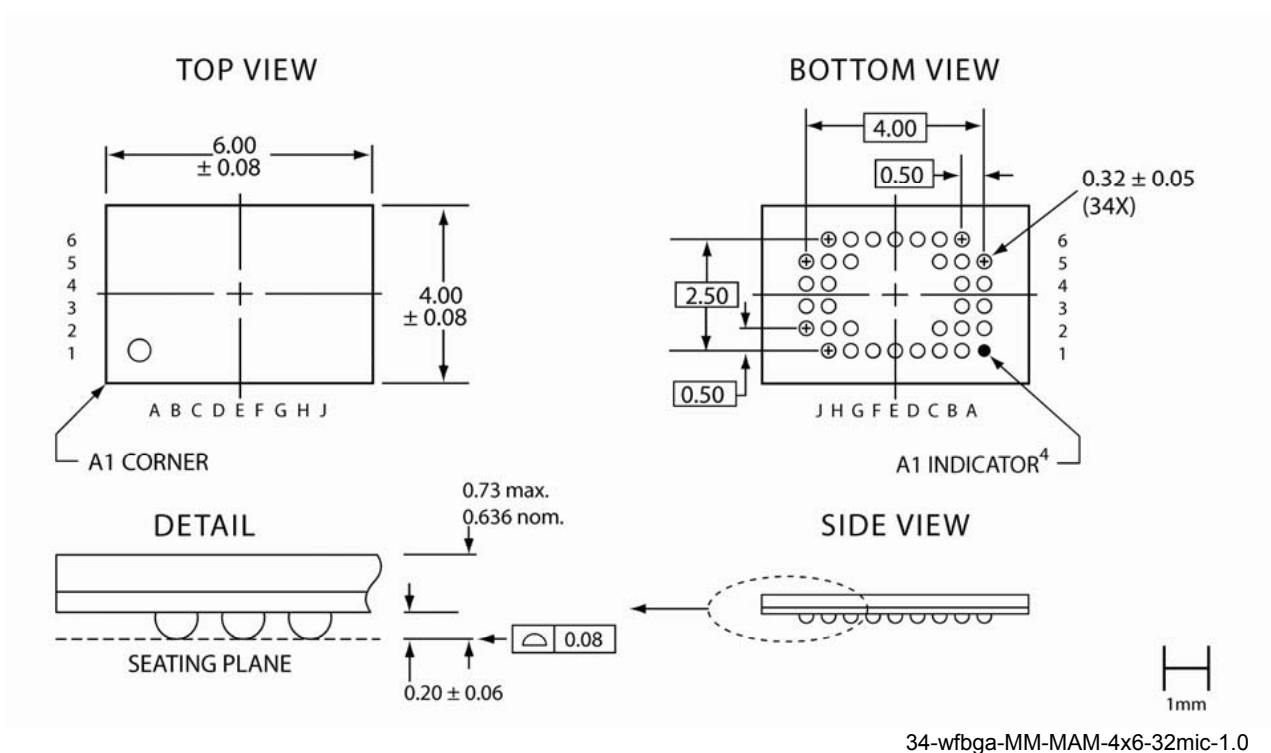

**Note:**

1. Complies with JEDEC Publication 95, MO-207, Variant CB-4 except nominal ball size is larger and there are fewer balls.
2. All linear dimensions are in millimeters.
3. Coplanarity: 0.08 mm.
4. No ball is present in position A1; a gold-colored indicator is present.
5. Ball opening size is 0.29 mm ( $\pm 0.05$  mm).

---



---

## Package Outlines and Dimensions

---



---

### 34-Lead Very, Very Thin Fine-Pitch Ball Grid Array (MAME/F) - 4x6 mm Body [WFBGA]

**Note:** For the most current package drawings, please see the Microchip Packaging Specification located at <http://www.microchip.com/packaging>

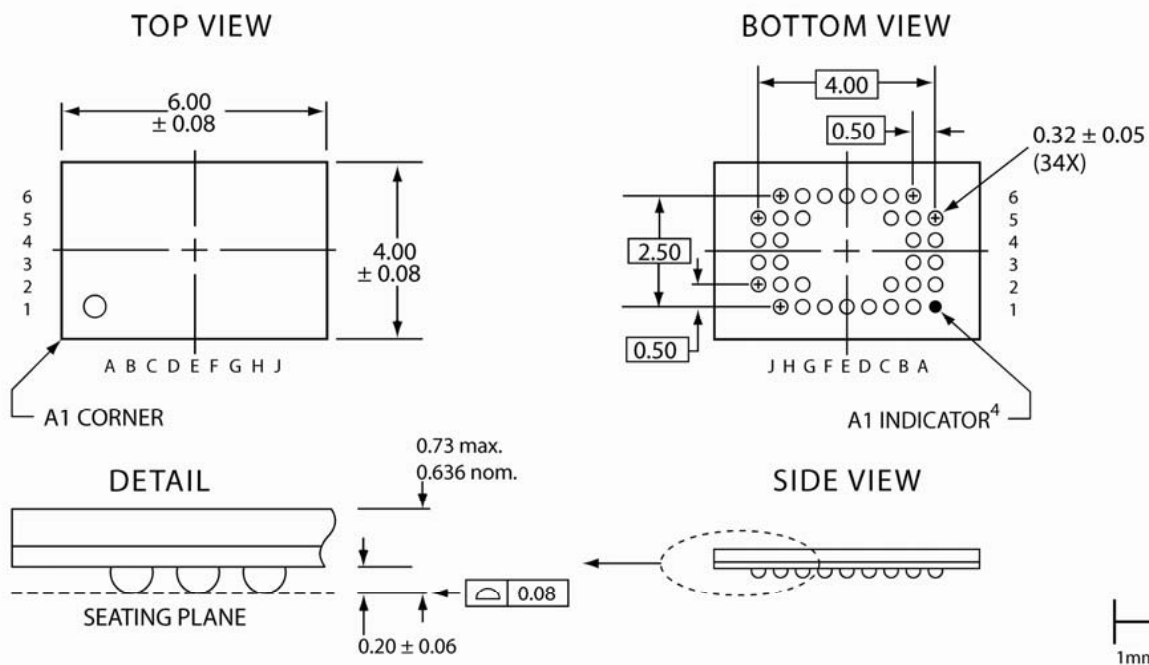

34-wfbga-MM-MAM-4x6-32mic-1.0

**Note:**

1. Complies with JEDEC Publication 95, MO-207, Variant CB-4 except nominal ball size is larger and there are fewer balls.
2. All linear dimensions are in millimeters.
3. Coplanarity: 0.08 mm.
4. No ball is present in position A1; a gold-colored indicator is present.
5. Ball opening size is 0.29 mm ( $\pm 0.05$  mm).

**Package Outlines and Dimensions**

**48-Lead Very, Very Thin Fine-Pitch Ball Grid Array (M1QE/F) - 4x6 mm Body [WFBGA]**

**Note:** For the most current package drawings, please see the Microchip Packaging Specification located at <http://www.microchip.com/packaging>

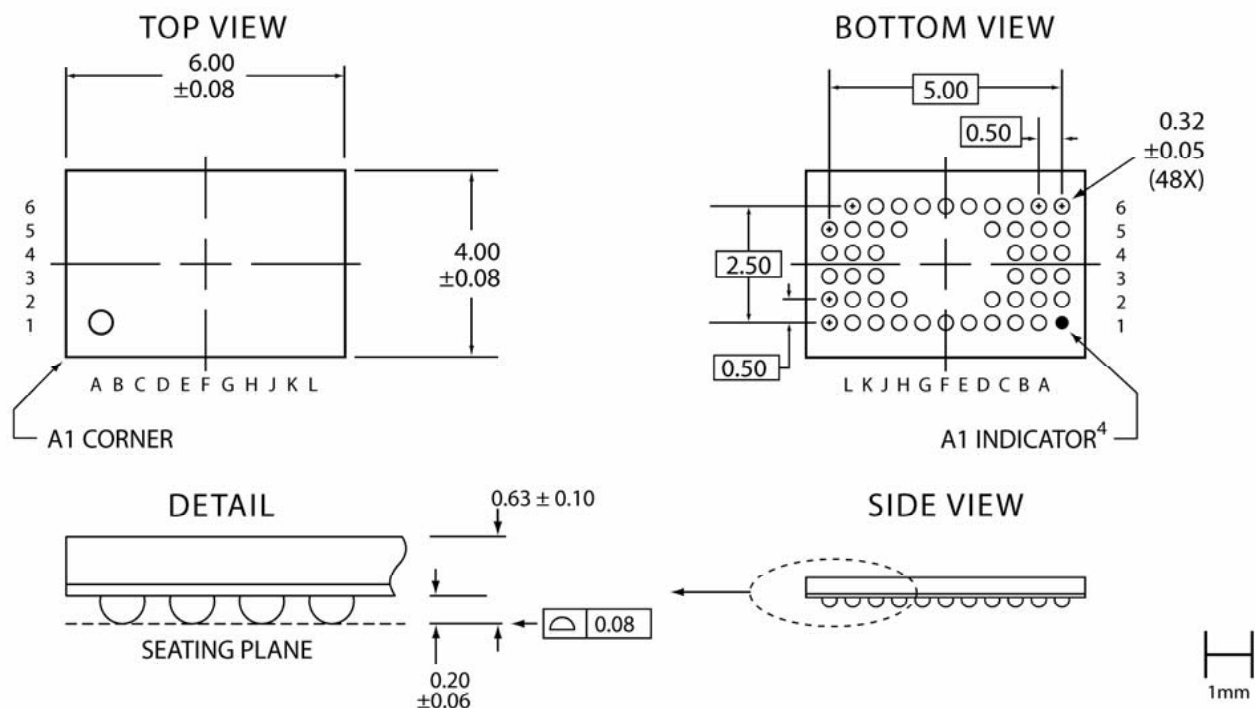

48-wfbga-M1Q-4x6-32mic-6.0

**Note:**

1. Complies with JEDEC Publication 95, MO-207, Variant C2B-4, dimensions except nominal ball width is larger.
2. All linear dimensions are in millimeters.
3. Coplanarity: 0.08 mm.
4. No ball is present in position A1; a gold-colored indicator is present.
5. Ball opening size is 0.29 mm (± 0.05 mm).

---



---

## Package Outlines and Dimensions

---



---

### 48-Lead Very, Very Thin Fine-Pitch Ball Grid Array (M2QE/F) - 5x6 mm Body [WFBGA]

**Note:** For the most current package drawings, please see the Microchip Packaging Specification located at <http://www.microchip.com/packaging>

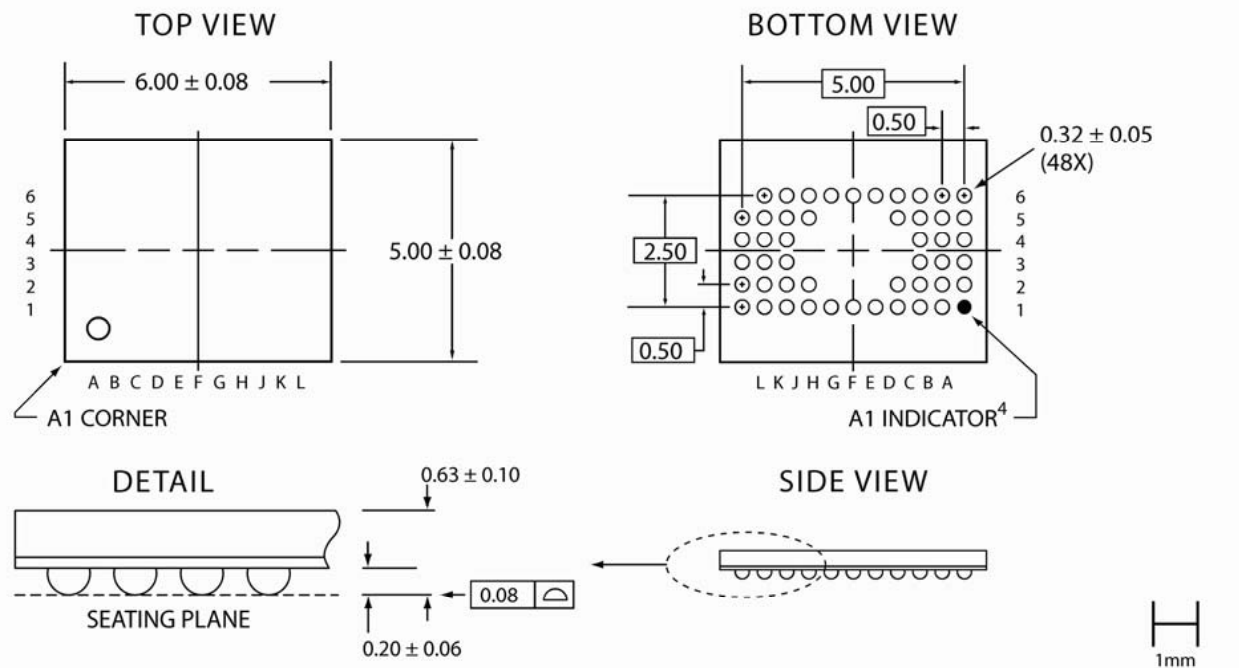

**Note:**

1. Although many dimensions are similar to those of JEDEC Publication 95, MO-225, this specific package is not registered.
2. All linear dimensions are in millimeters.
3. Coplanarity: 0.08 mm
4. No ball is present in position A1; a gold-colored indicator is present.
5. Ball opening size is 0.29 mm ( $\pm 0.05$  mm)

**Package Outlines and Dimensions**

**48-Lead Very, Very Thin Fine-Pitch Ball Grid Array (MAQE/F) - 4x6 mm Body [WFBGA]**

**Note:** For the most current package drawings, please see the Microchip Packaging Specification located at <http://www.microchip.com/packaging>

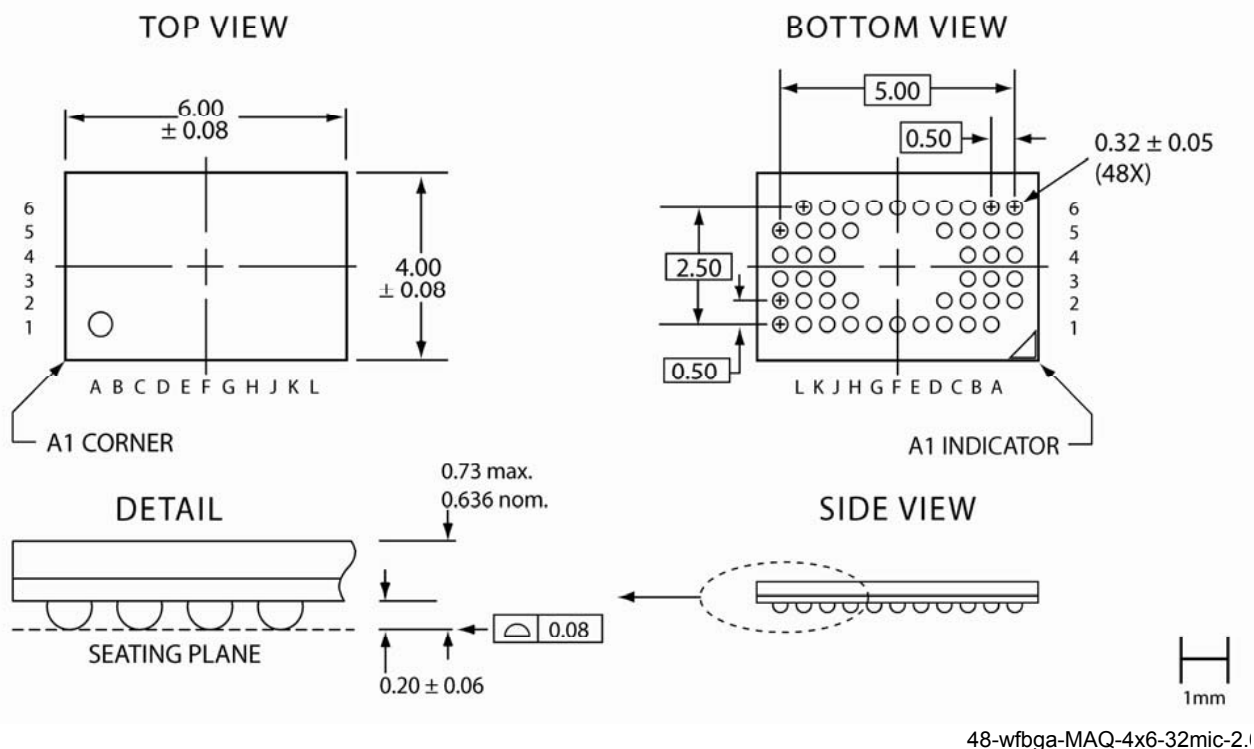

48-wfbga-MAQ-4x6-32mic-2.1

**Note:**

1. Complies with JEDEC Publication 95, MO-207, Variant CB-4 except nominal ball size is larger and bottom side A1 indicator is triangle at corner.
2. All linear dimensions are in millimeters.
3. Coplanarity: 0.08 mm
4. Ball opening size is 0.29 mm ( $\pm 0.05$  mm)

## Package Outlines and Dimensions

### 48-Lead Very, Very Thin Fine-Pitch Ball Grid Array (MBQE/F) - 5x6 mm Body [WFBGA]

**Note:** For the most current package drawings, please see the Microchip Packaging Specification located at <http://www.microchip.com/packaging>

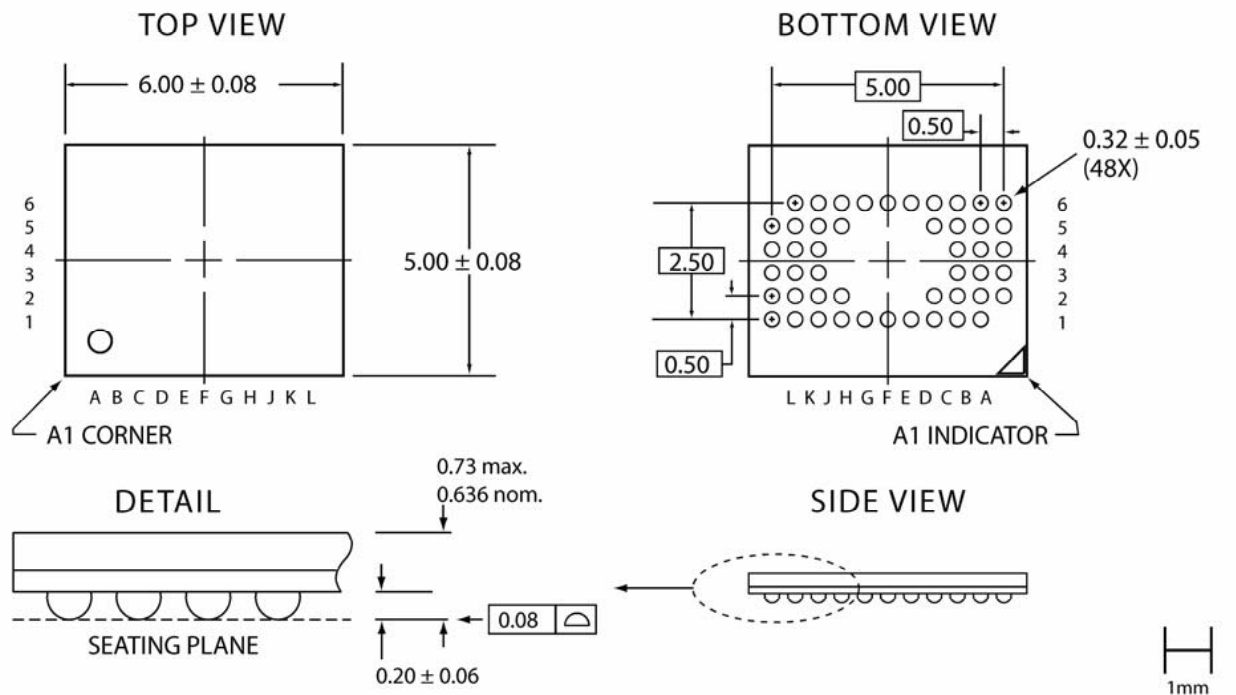

48-wfbga-MBQ-5x6-32mic-0

**Note:**

1. Although many dimensions are similar to those of JEDEC Publication 95, MO-225, this specific package is not registered.
2. All linear dimensions are in millimeters.
3. Coplanarity: 0.08 mm
4. Ball opening size is 0.29 mm ( $\pm 0.05$  mm)



**MICROCHIP**

---

---

**Package Outlines and Dimensions**

---

---

**NOTES:**



---

---

**Package Outlines and Dimensions**

---

---

**XFLGA**  
SST Legacy

**Package Outlines and Dimensions**

**48-Lead Extremely Thin Fine-Pitch Land Grid Array (C1QE/F) - 4x6 mm Body [XFLGA]**

**Note:** For the most current package drawings, please see the Microchip Packaging Specification located at <http://www.microchip.com/packaging>

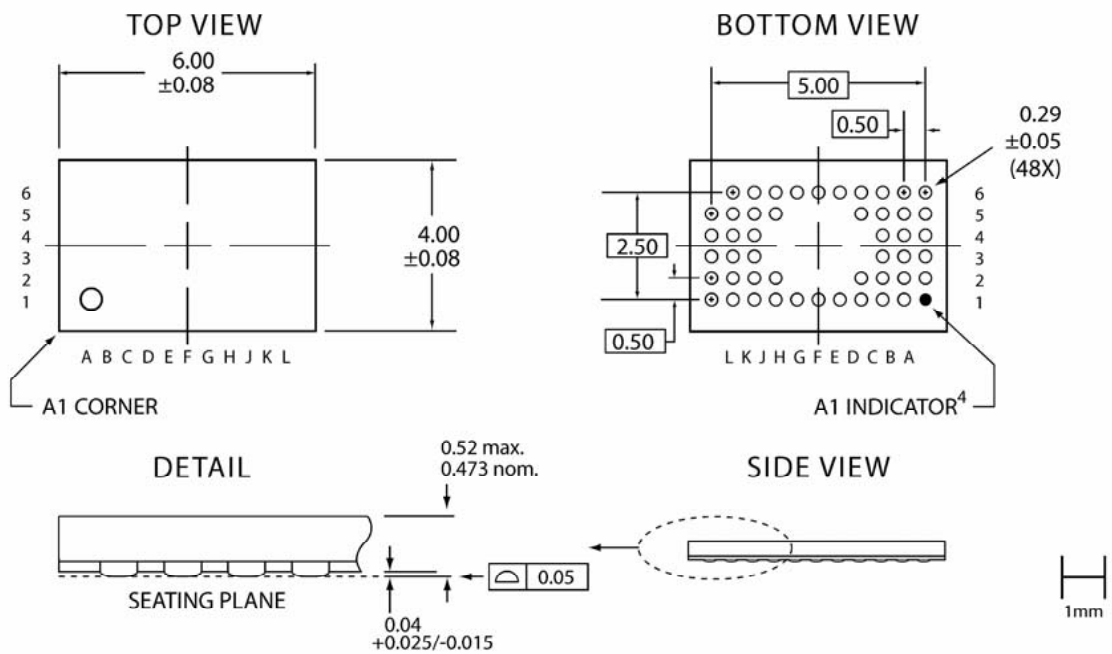

48-xflga-C1Q-4x6-29mic-6.0

**Note:**

1. Complies with JEDEC Publication 95, MO-207, variant CZB-4, dimensions except bump height is much less.
2. All linear dimensions are in millimeters.
3. Coplanarity: 0.05 mm.
4. No ball is present at A1; a gold-colored indicator is present.
5. Bump opening size is 0.29 (±0.05 mm).

## Package Outlines and Dimensions

### 48-Lead Extremely Thin Fine-Pitch Land Grid Array (CAQE/F) - 4x6 mm Body [XFLGA]

**Note:** For the most current package drawings, please see the Microchip Packaging Specification located at <http://www.microchip.com/packaging>

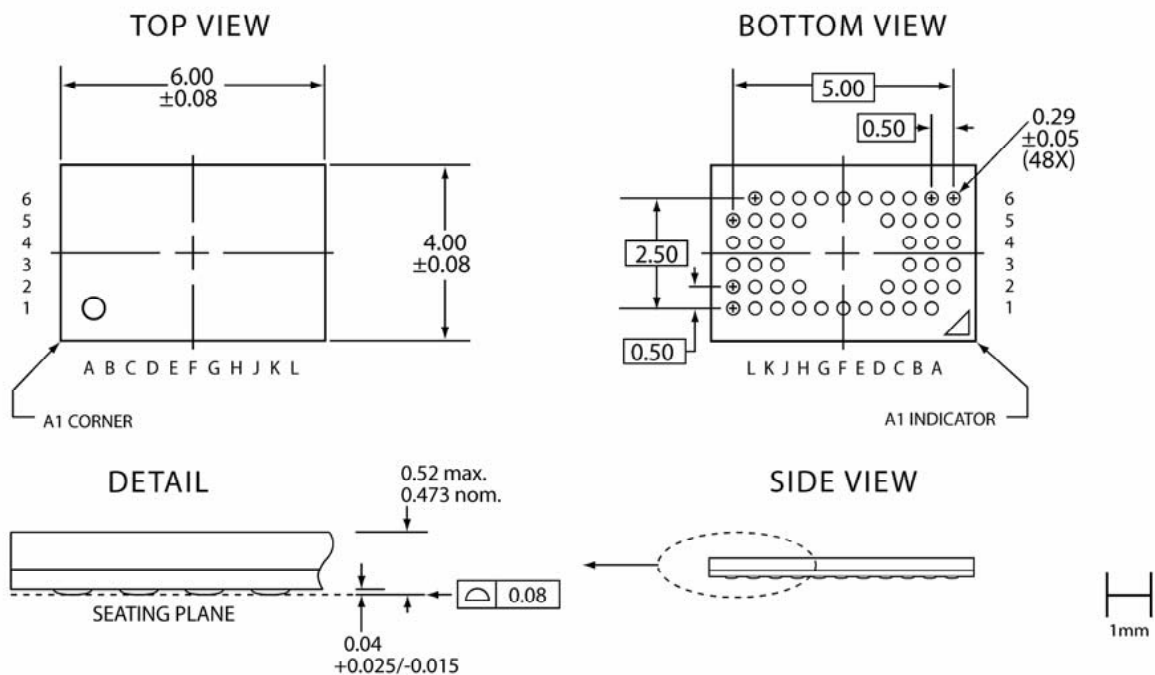

48-xflga-CAQ-4x6-29mic-6.0

**Note:**

1. Complies with JEDEC Publication 95, MO-207, variant CZB-4, dimensions except the bump height is much less, and the A1 indicator is different.
2. All linear dimensions are in millimeters.
3. Coplanarity: 0.08 mm.
4. For low-profile mounting on PCB, SST recommends underfill for best solder joint reliability.

**Package Outlines and Dimensions**

**48-Lead Extremely Thin Fine-Pitch Land Grid Array (C2QE/F) - 5x6 mm Body [XFLGA]**

**Note:** For the most current package drawings, please see the Microchip Packaging Specification located at <http://www.microchip.com/packaging>

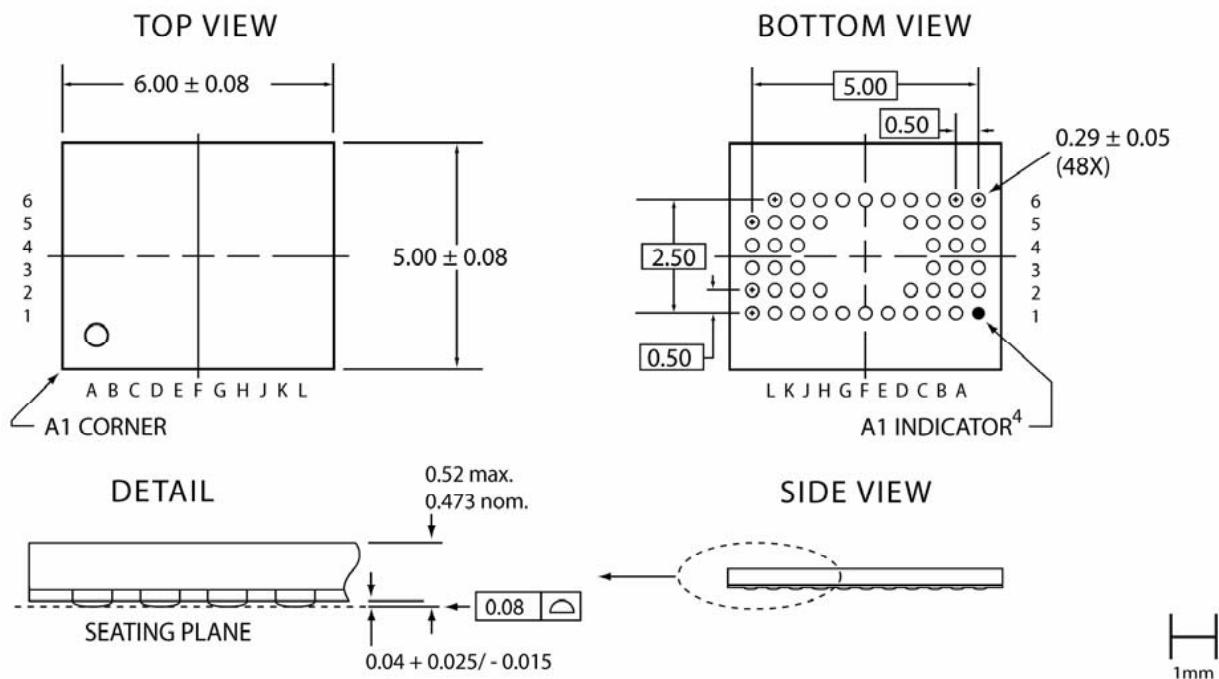

48-xflga-C2Q-5x6-29mic-NR

**Note:**

1. Although many dimensions are similar to those of JEDEC Publication 95, MO-222, this specific package is not registered.
2. All linear dimensions are in millimeters.
3. For low-profile mounting on PCB, SST recommends underfill for best solder joint reliability.
4. Coplanarity: 0.08 mm
5. No bump is present in position A1; a gold-colored indicator is present.

---



---

## Package Outlines and Dimensions

---



---

### 48-Lead Extremely Thin Fine-Pitch Land Grid Array (CBQE/F) - 5x6 mm Body [XFLGA]

**Note:** For the most current package drawings, please see the Microchip Packaging Specification located at <http://www.microchip.com/packageing>

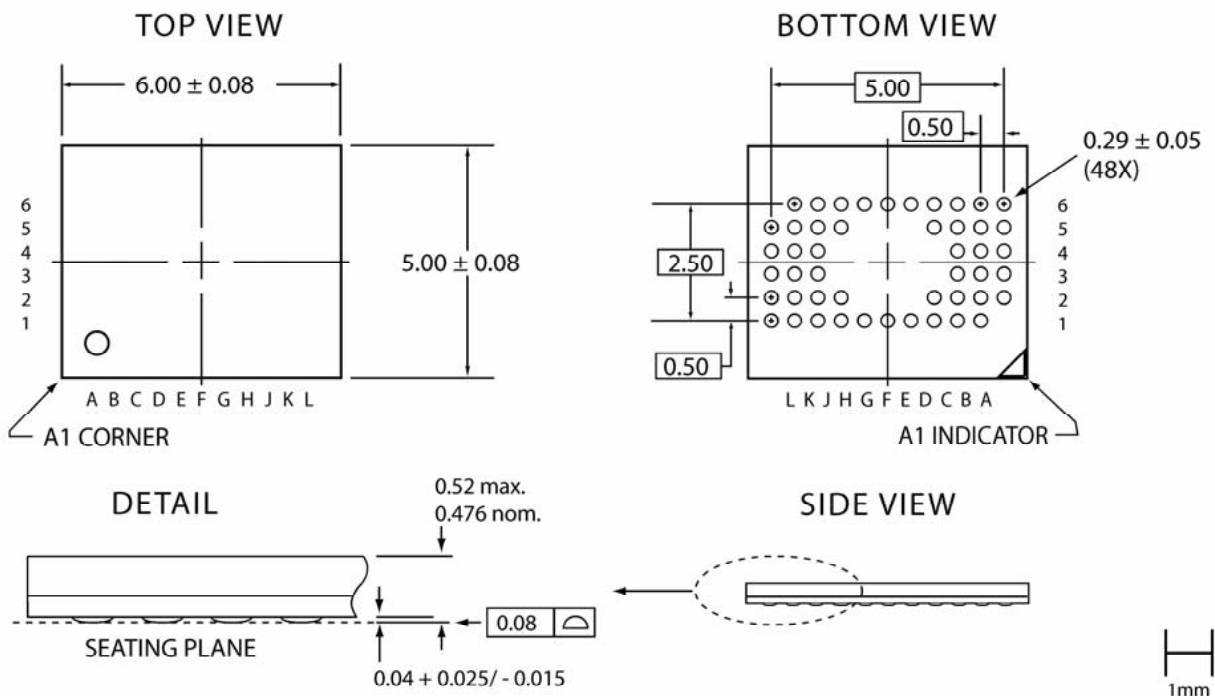

48-xflga-CBQ-5x6-29mic-0

**Note:**

1. Although many dimensions are similar to those of JEDEC Publication 95, MO-222, this specific package is not registered.
2. All linear dimensions are in millimeters.
3. For low-profile mounting on PCB, SST recommends underfill for best solderjoint reliability.
4. Coplanarity: 0.08 mm



**MICROCHIP**

---

---

**Package Outlines and Dimensions**

---

---

**NOTES:**

---

---

**Package Outlines and Dimensions**

---

---

**TQFP**

SST Legacy

**Package Outlines and Dimensions**

**44-Lead Thin Quad Flat Pack (TQJE/F) - 10x10 mm Body [TQFP]**

**Note:** For the most current package drawings, please see the Microchip Packaging Specification located at <http://www.microchip.com/packaging>

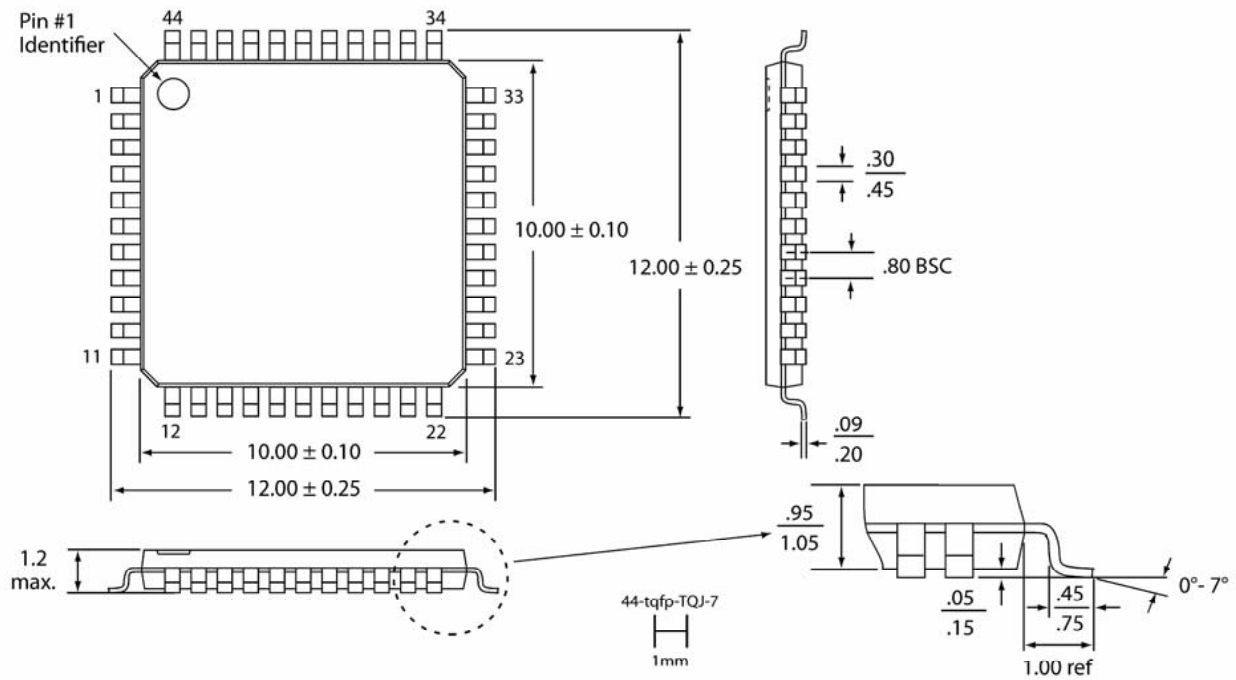

44-tqfp-TQJ-7

**Note:**

1. Complies with JEDEC publication 95 MS-026 ACB dimensions, although some dimensions may be more stringent.
2. All linear dimensions are in millimeters (min/max).
3. Coplanarity:  $0.1 (\pm 0.05)$  mm.
4. Package body dimensions do not include mold flash. Maximum allowable mold flash is  $.25$ mm.



---

---

**Package Outlines and Dimensions**

---

---

**TSOP**

SST Legacy

**Package Outlines and Dimensions**

**32-Lead Thin Small Outline Package (EHE/F) - [TSOP]**

**Note:** For the most current package drawings, please see the Microchip Packaging Specification located at <http://www.microchip.com/packaging>

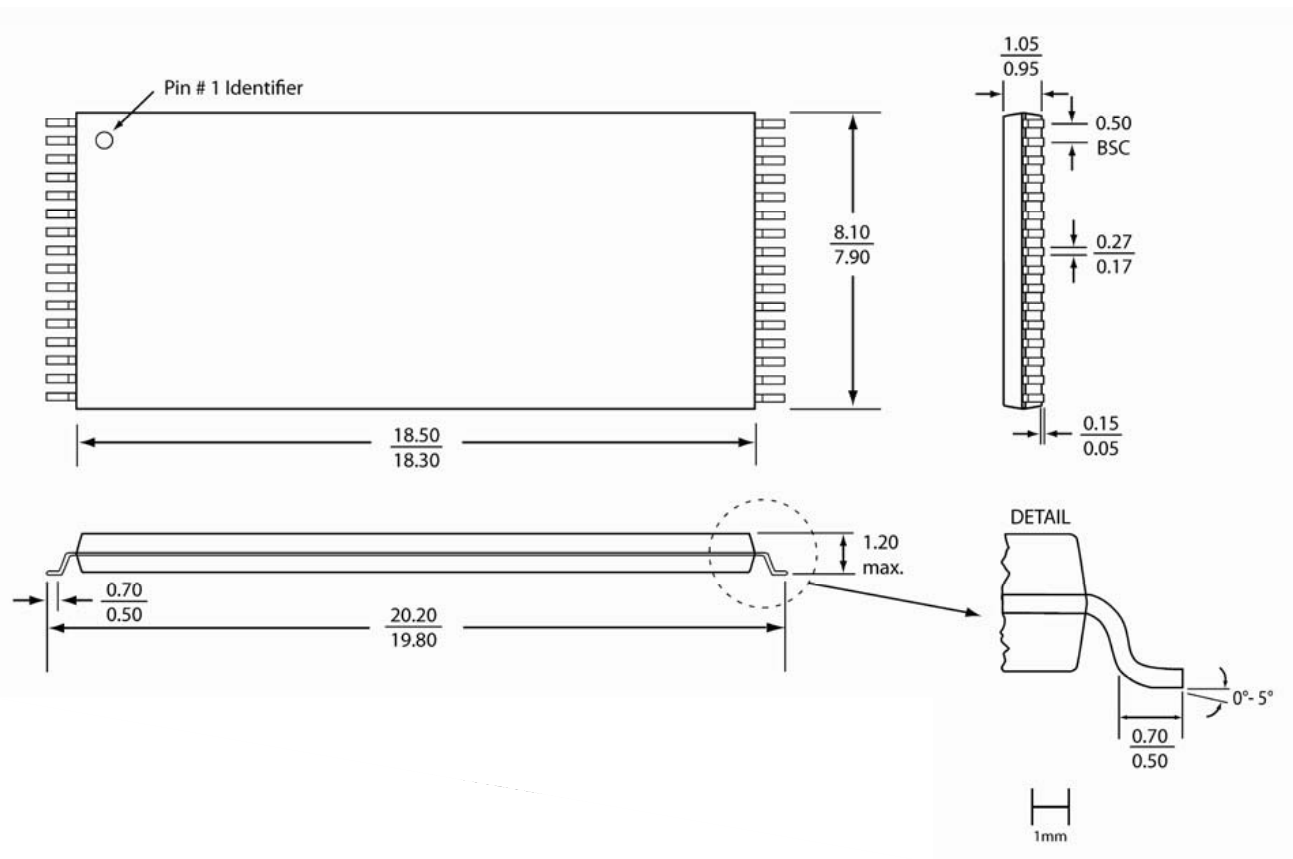

32-tsop-EH-7

**Note:**

1. Complies with JEDEC publication 95 MO-142 BD dimensions, although some dimensions may be more stringent.
2. All linear dimensions are in millimeters (max/min).
3. Coplanarity: 0.1 mm
4. Maximum allowable mold flash is 0.15 mm at the package ends, and 0.25mm between leads.

**Package Outlines and Dimensions**

**32-Lead Thin Small Outline Package (WHE/F) - [TSOP]**

**Note:** For the most current package drawings, please see the Microchip Packaging Specification located at <http://www.microchip.com/packaging>

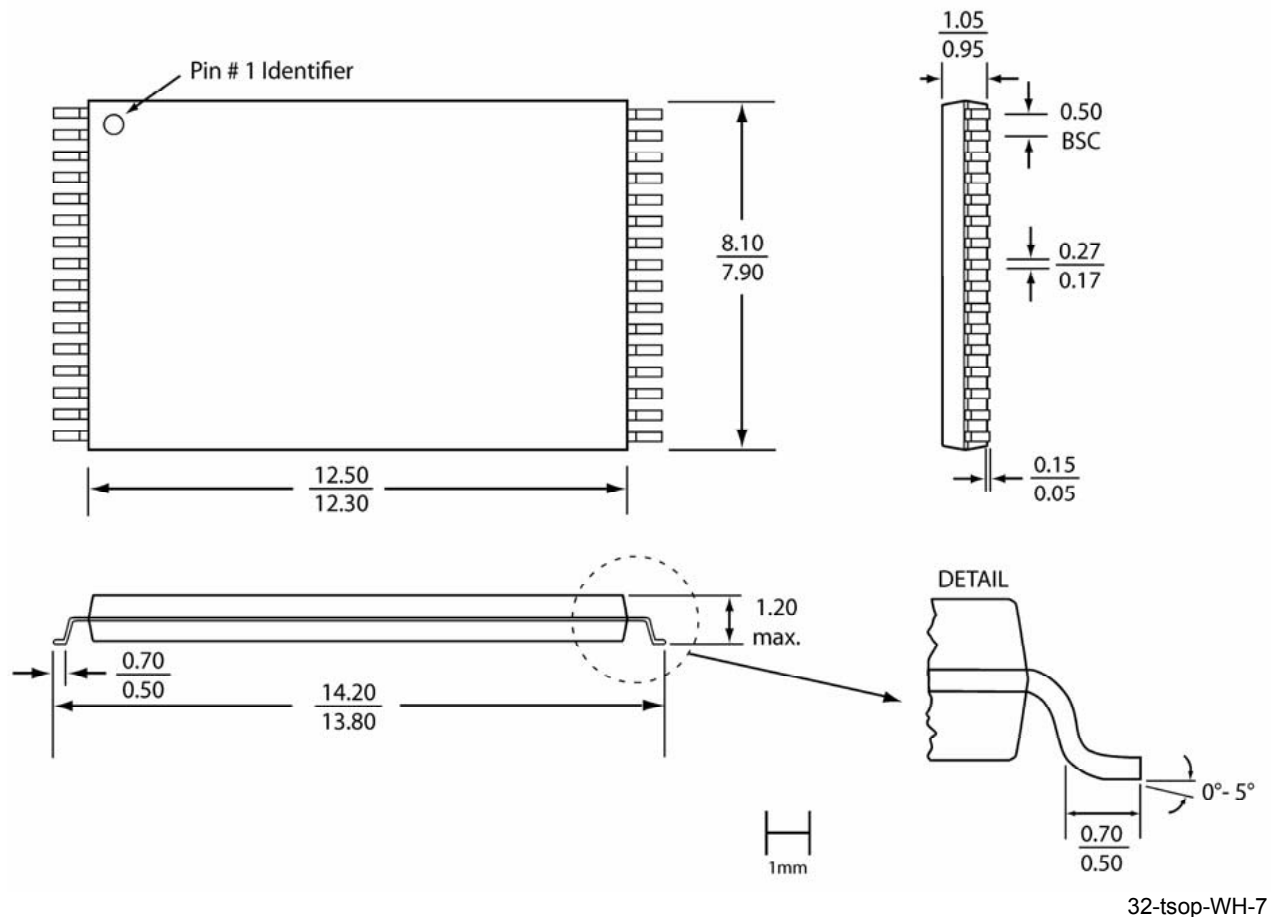

**Note:**

1. Complies with JEDEC publication 95 MO-142 BA dimensions, although some dimensions may be more stringent.
2. All linear dimensions are in millimeters (max/min).
3. Coplanarity: 0.1 mm
4. Maximum allowable mold flash is 0.15 mm at the package ends, and 0.25 mm between leads.

**Package Outlines and Dimensions**

**40-Lead Thin Small Outline Package (EIE/F) - [TSOP]**

**Note:** For the most current package drawings, please see the Microchip Packaging Specification located at <http://www.microchip.com/packaging>

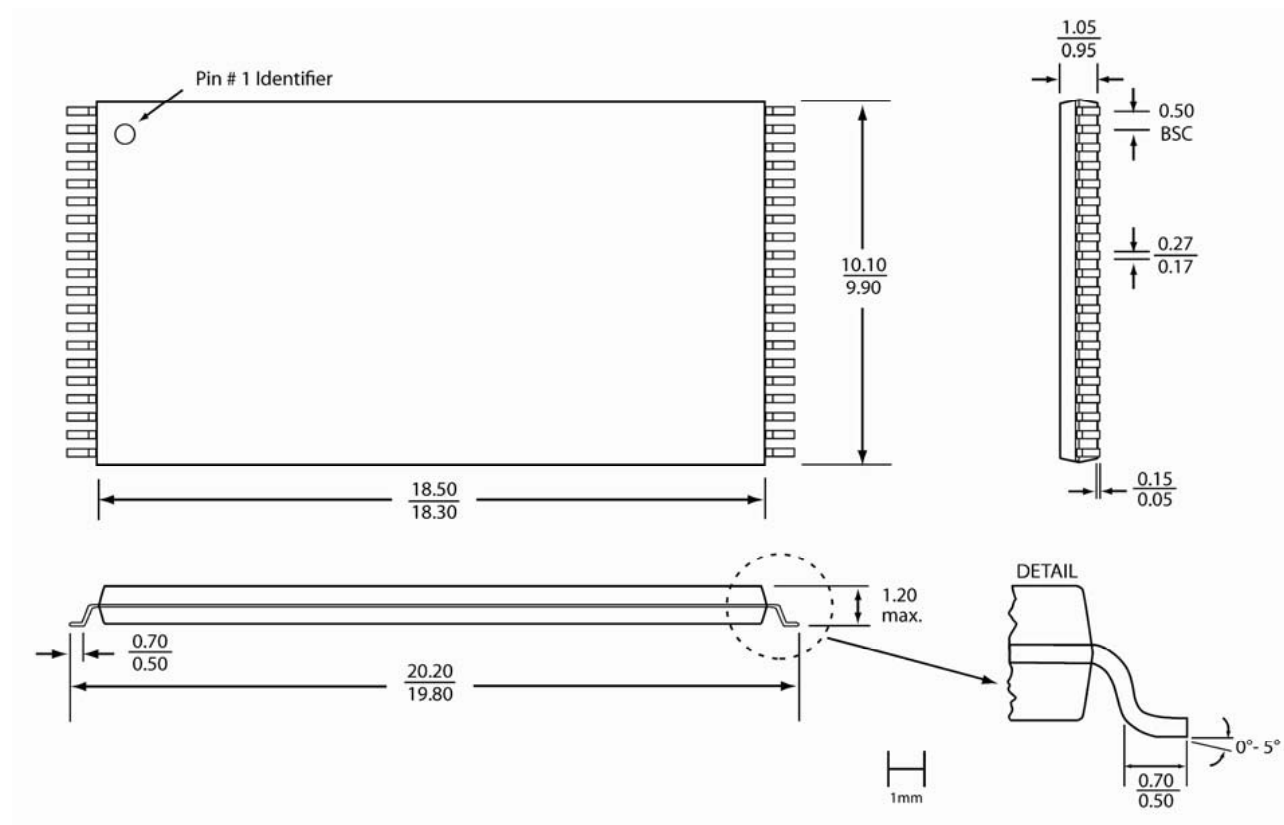

40-tsop-EI-7

**Note:**

1. Complies with JEDEC publication 95 MO-142 CD dimensions, although some dimensions may be more stringent.
2. All linear dimensions are in millimeters (max/min).
3. Coplanarity: 0.1 mm
4. Maximum allowable mold flash is 0.15 mm at the package ends, and 0.25 mm between leads.

**Package Outlines and Dimensions**

**40-Lead Thin Small Outline Package (WIE/F) - [TSOP]**

**Note:** For the most current package drawings, please see the Microchip Packaging Specification located at <http://www.microchip.com/packaging>

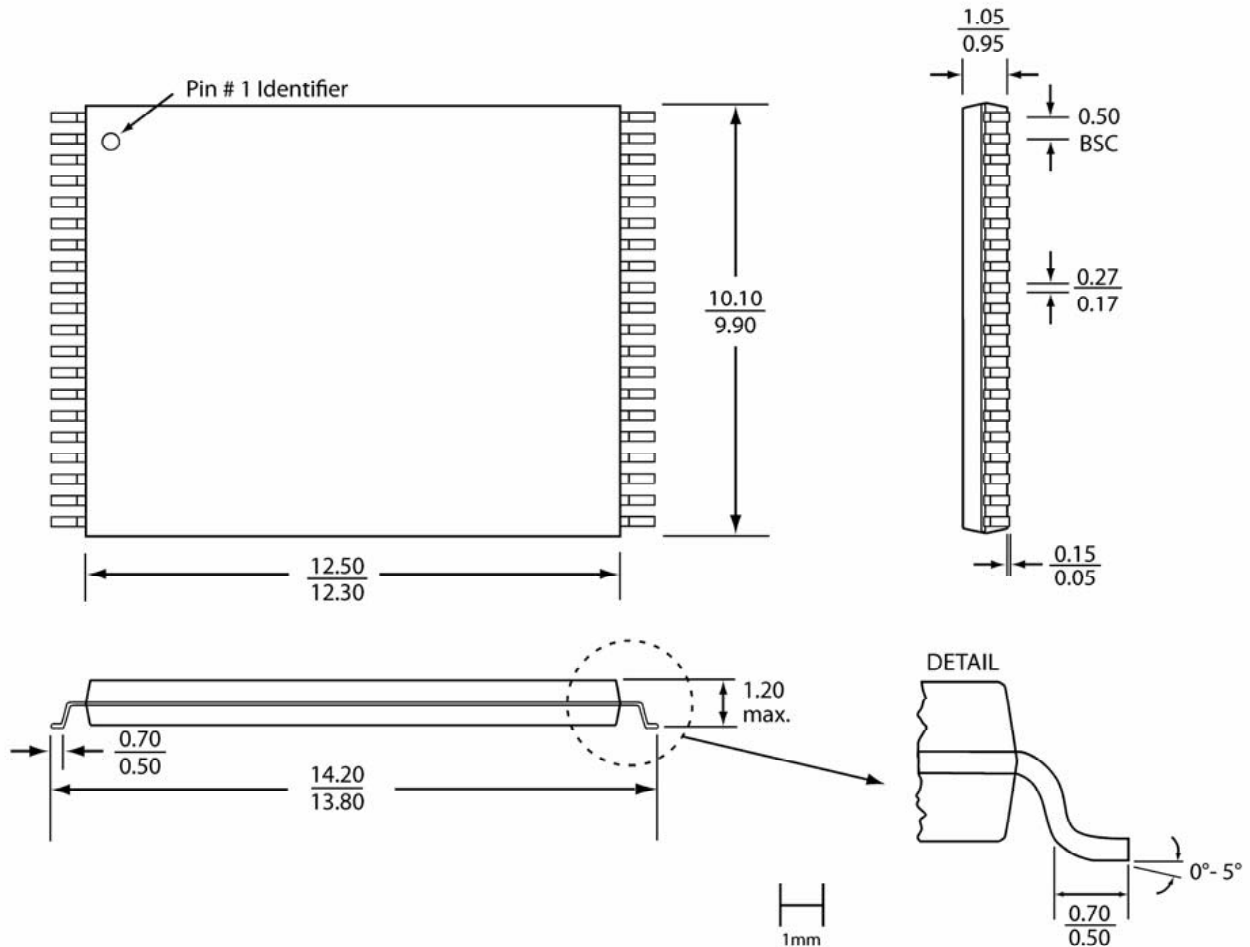

40-tsop-WI-7

**Note:**

1. Complies with JEDEC publication 95 MO-142 CA dimensions, although some dimensions may be more stringent.
2. All linear dimensions are in millimeters (max/min).
3. Coplanarity: 0.1 mm
4. Maximum allowable mold flash is 0.15 mm at the package ends, and 0.25 mm between leads.

**Package Outlines and Dimensions**

**48-Lead Thin Small Outline Package (EKE/F) - [TSOP]**

**Note:** For the most current package drawings, please see the Microchip Packaging Specification located at <http://www.microchip.com/packaging>

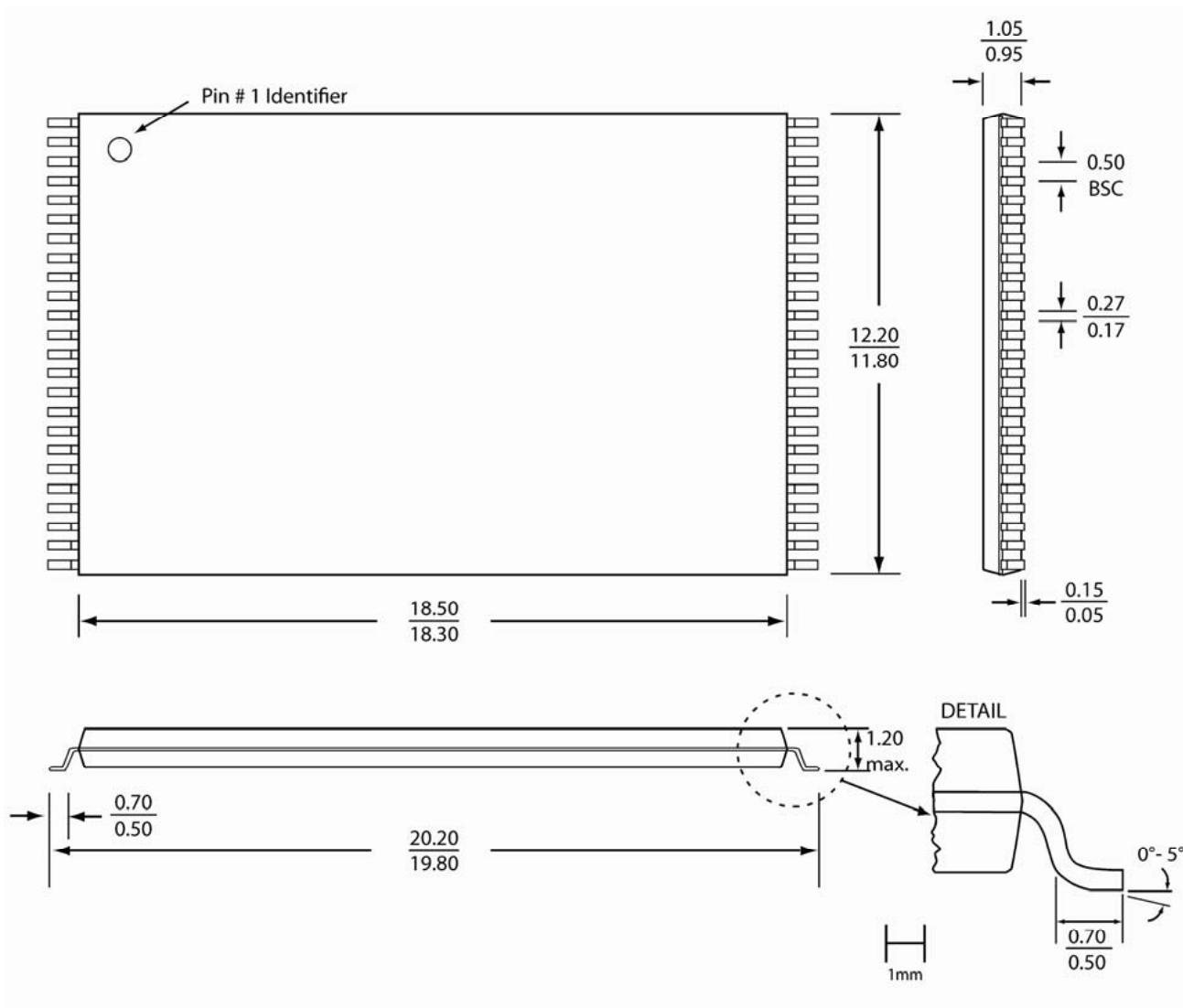

48-tsop-EK-8

**Note:**

1. Complies with JEDEC publication 95 MO-142 DD dimensions, although some dimensions may be more stringent.
2. All linear dimensions are in millimeters (max/min).
3. Coplanarity: 0.1 mm
4. Maximum allowable mold flash is 0.15 mm at the package ends, and 0.25 mm between leads.

**Package Outlines and Dimensions**

**56-Lead Thin Small Outline Package (ENE/F) - [TSOP]**

**Note:** For the most current package drawings, please see the Microchip Packaging Specification located at <http://www.microchip.com/packaging>

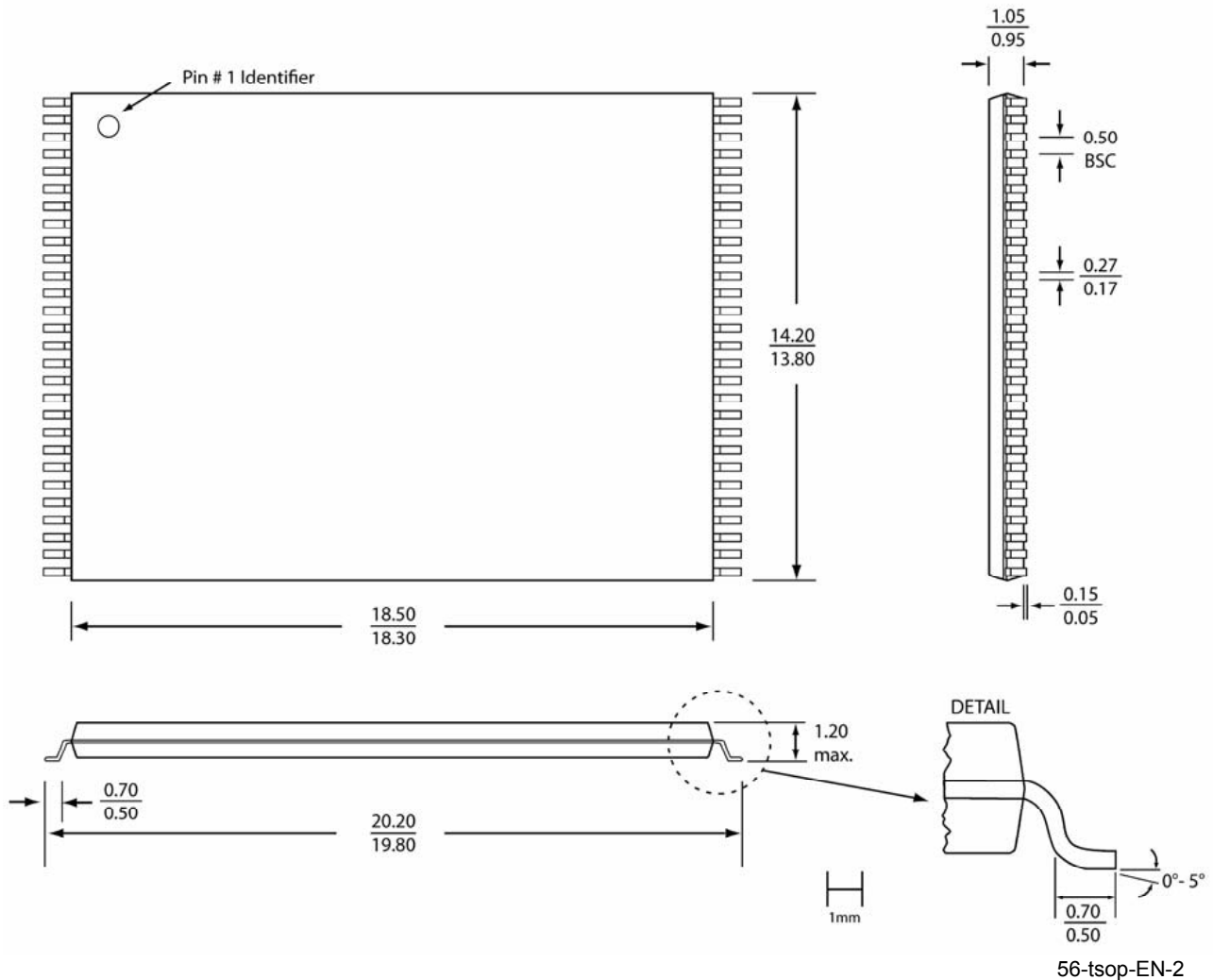

**Note:**

1. Complies with JEDEC publication 95 MO-142 EC dimensions, although some dimensions may be more stringent.
2. All linear dimensions are in millimeters (max/min).
3. Coplanarity: 0.1 mm
4. Maximum allowable mold flash is 0.15 mm at the package ends, and 0.25 mm between leads.



**MICROCHIP**

---

---

**Package Outlines and Dimensions**

---

---

NOTES:



---

---

**Package Outlines and Dimensions**

---

---

**UQFN**

SST Legacy

**Package Outlines and Dimensions**

**6-Lead Ultra Thin Quad Flatpack No-Leads (QU6E/F) - 3x1.6 mm Body [UQFN]**

**Note:** For the most current package drawings, please see the Microchip Packaging Specification located at <http://www.microchip.com/packaging>

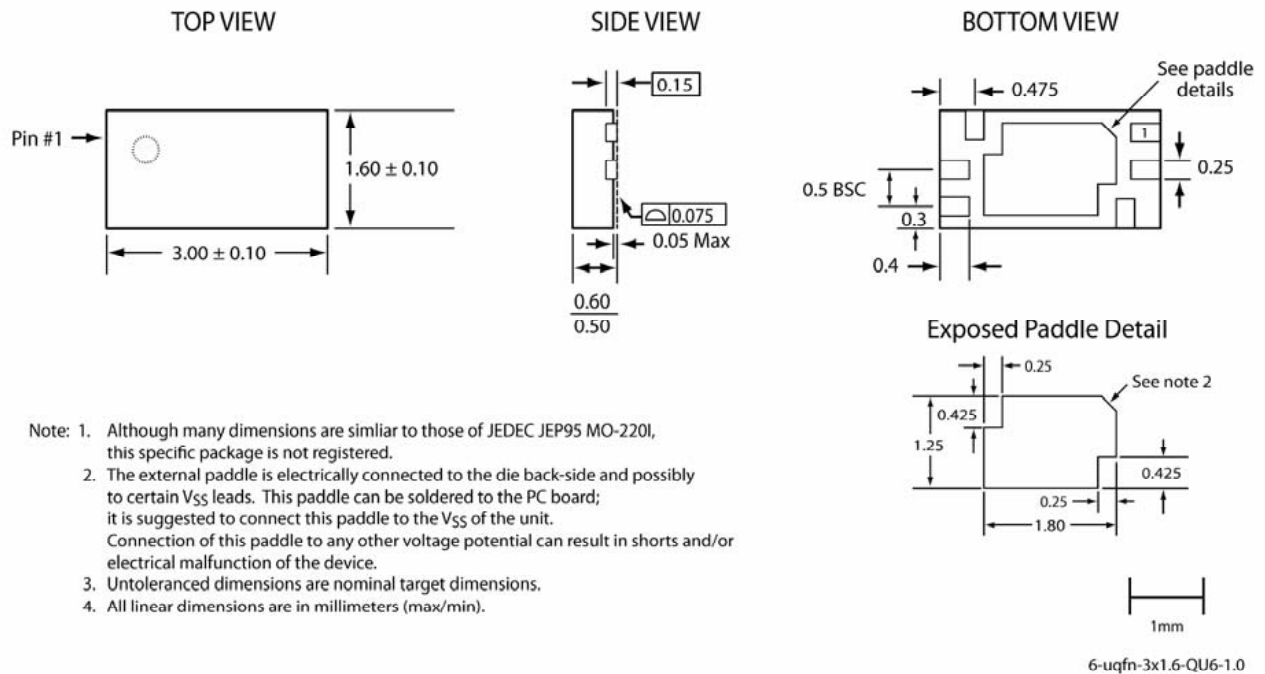

---



---

## Package Outlines and Dimensions

---



---

### 12-Lead Ultra Thin Quad Flatpack No-Leads (QUBE/F) - 2x2 mm Body [UQFN]

**Note:** For the most current package drawings, please see the Microchip Packaging Specification located at <http://www.microchip.com/packaging>

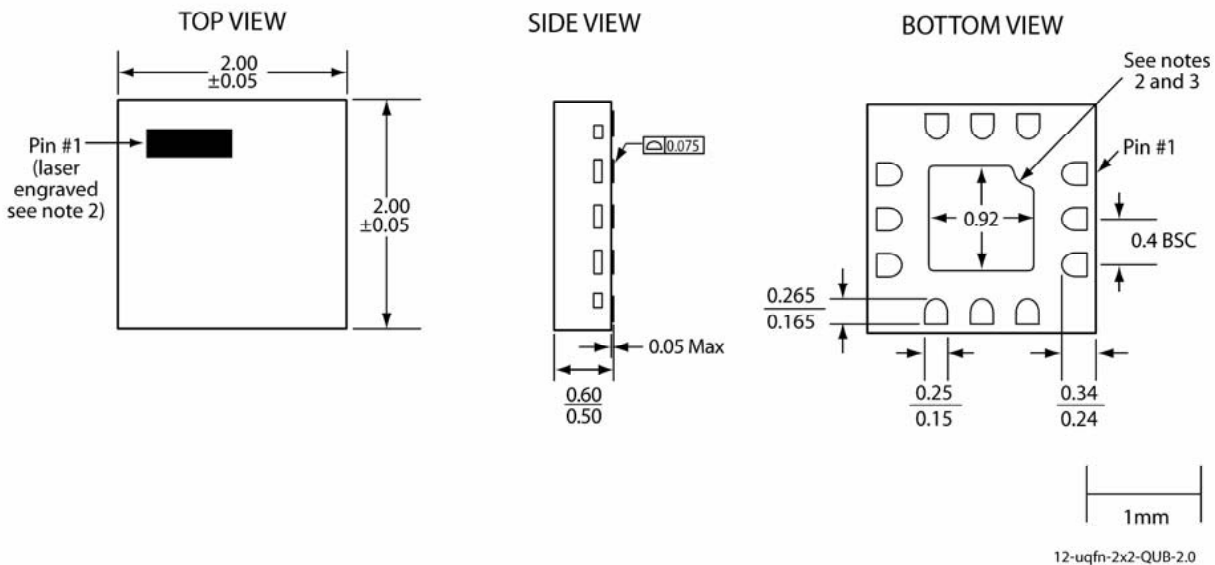

**Note:**

1. Similar to JEDEC JEP95 UQFN/USON variants, though number of contacts and some dimensions are different.
2. The topside pin #1 indicator is laser engraved; its approximate shape and location is as shown.
3. From the bottom view, the pin #1 indicator may be either a curved indent or a 45-degree chamfer.
4. The external paddle is electrically connected to the die back-side and to VSS.  
This paddle must be soldered to the PC board; it is required to connect this paddle to the VSS of the unit.  
Connection of this paddle to any other voltage potential will result in shorts and electrical malfunction of the device.
5. Untoleranced dimensions are nominal target dimensions.
6. All linear dimensions are in millimeters (max/min).

**Package Outlines and Dimensions**

**16-Lead Ultra Thin Quad Flatpack No-Leads (QUCE/F) - 3x3 mm Body [UQFN]**

**Note:** For the most current package drawings, please see the Microchip Packaging Specification located at <http://www.microchip.com/packaging>

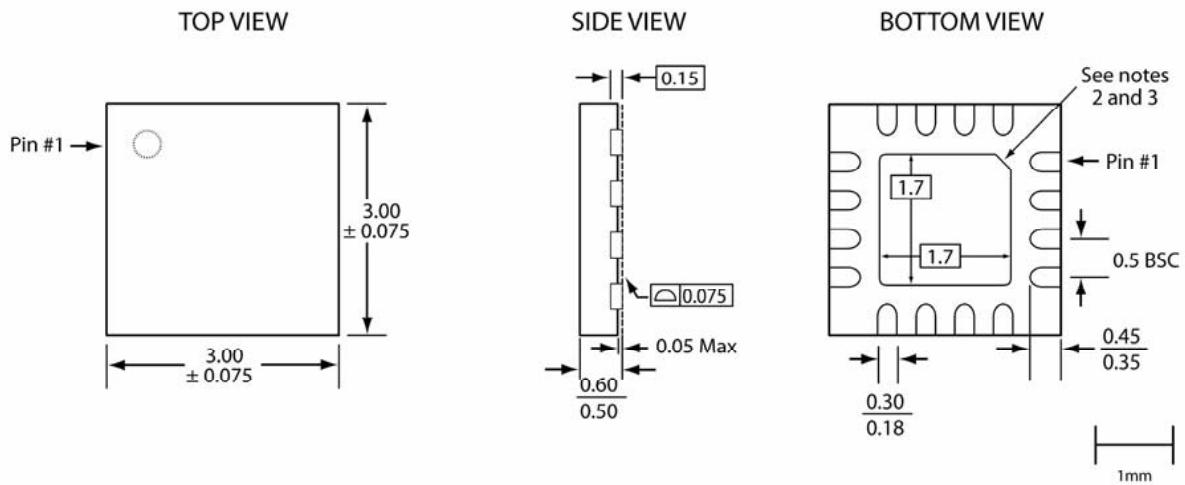

16-uqfn-3x3-QUC-0.0

**Note:**

1. Complies with JEDEC JEP95 MO-248D, variant UEED-4 except external paddle nominal dimensions.
2. From the bottom view, the pin #1 indicator may be either a 45-degree chamfer or a half-circle notch.
3. The external paddle is electrically connected to the die back-side and possibly to certain VSS leads. This paddle can be soldered to the PC board; it is suggested to connect this paddle to the VSS of the unit. Connection of this paddle to any other voltage potential can result in shorts and/or electrical malfunction of the device.
4. Untoleranced dimensions are nominal target dimensions.
5. All linear dimensions are in millimeters (max/min).

---



---

## Package Outlines and Dimensions

---



---

### 20-Lead Ultra Thin Quad Flatpack No-Leads (Q3DE/F) - 3x3 mm Body [UQFN]

**Note:** For the most current package drawings, please see the Microchip Packaging Specification located at <http://www.microchip.com/packaging>

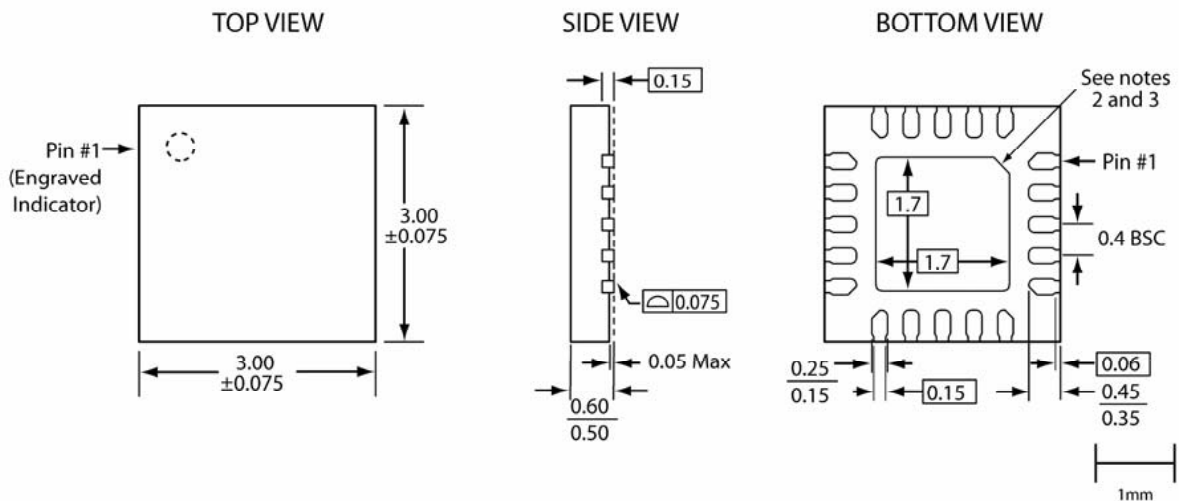

20-uqfn-3x3-Q3D-1.0

**Note:**

1. Complies with JEDEC JEP95 MO-248E, variant UEEE except external paddle nominal dimensions, shape of terminals at the body edge and shape of inboard terminals near the corners.
2. From the bottom view, the pin #1 indicator may be either a 45-degree chamfer or a half-circle notch.
3. The external paddle is electrically connected to the die back-side and to VSS.  
This paddle must be soldered to the PC board; it is required to connect this paddle to the VSS of the unit.  
Connection of this paddle to any other voltage potential will result in shorts and electrical malfunction of the device.
4. Untoleranced dimensions are nominal target dimensions.
5. All linear dimensions are in millimeters (max/min).

**Package Outlines and Dimensions**

**20-Lead Ultra Thin Quad Flat Pack, No Lead (GN) - 4x4x0.55 mm Body (UQFN)**

**Note:** For the most current package drawings, please see the Microchip Packaging Specification located at <http://www.microchip.com/packaging>

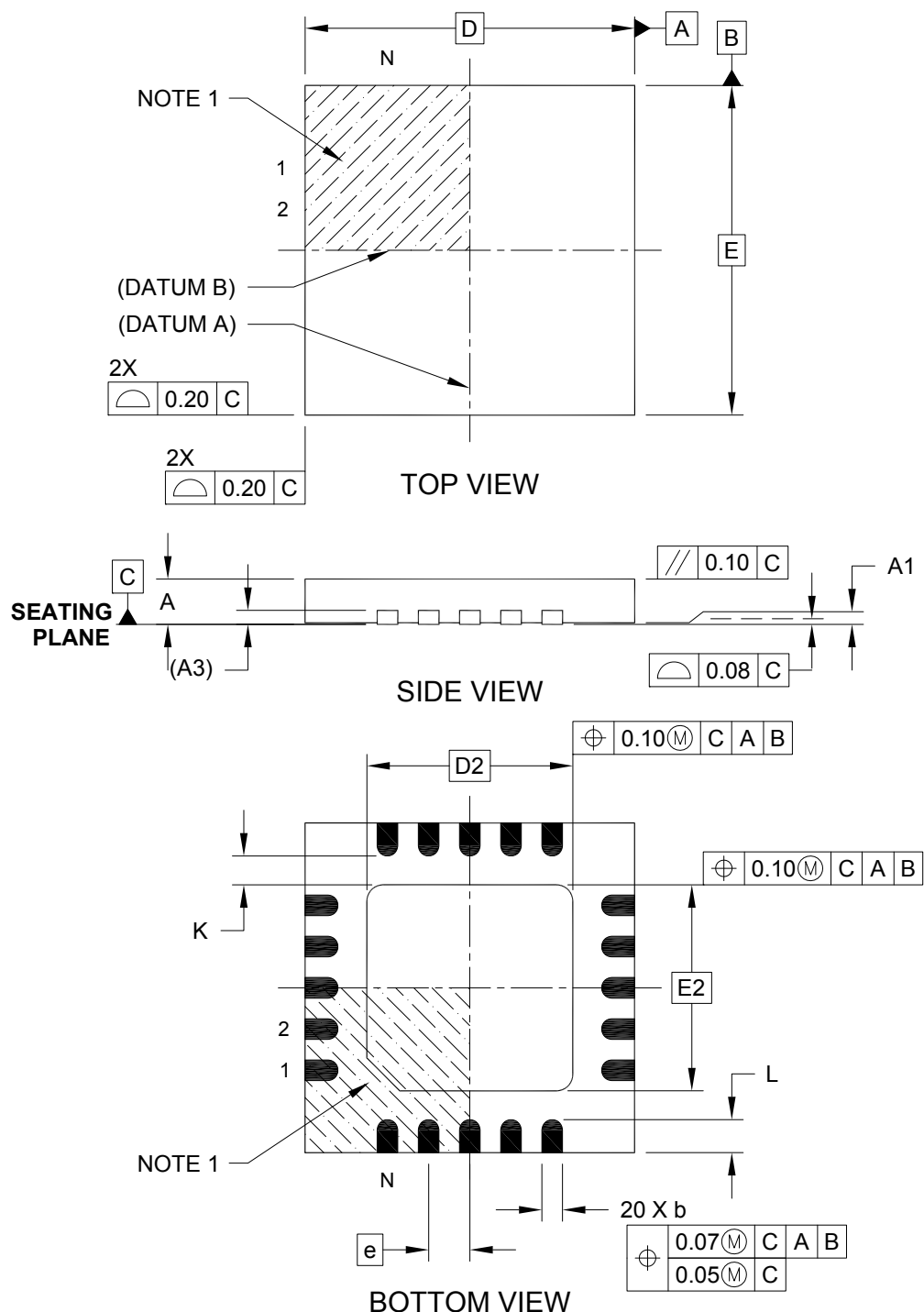

---



---

## Package Outlines and Dimensions

---



---

### 20-Lead Ultra Thin Quad Flat Pack, No Lead (GN) - 4x4x0.55 mm Body (UQFN)

**Note:** For the most current package drawings, please see the Microchip Packaging Specification located at <http://www.microchip.com/packaging>

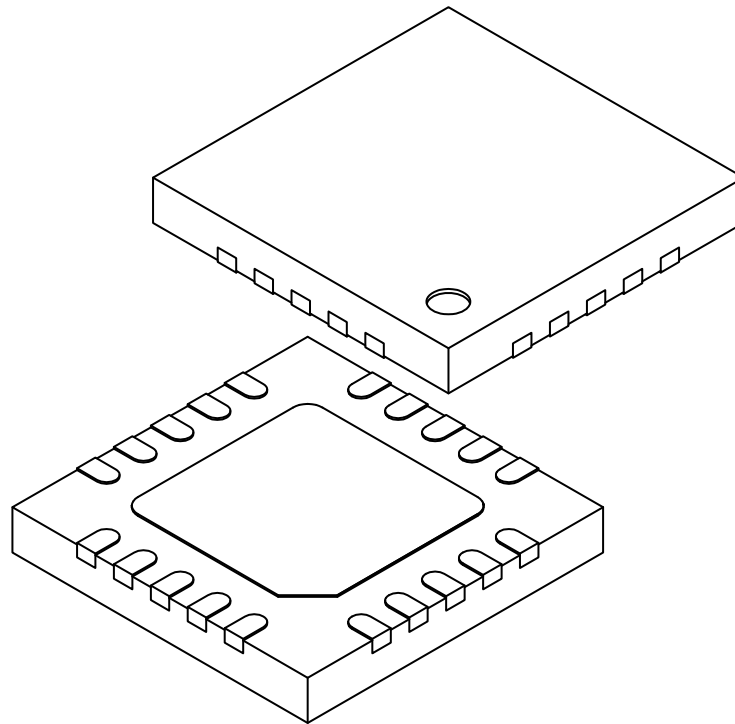

		MILLIMETERS		
Units				
Dimension Limits		MIN	NOM	MAX
Number of Pins	N	20		
Pitch	e	0.50 BSC		
Overall Height	A	0.50	0.55	0.60
Standoff	A1	0.00	0.02	0.05
Terminal Thickness	(A3)	0.15 REF		
Overall Width	E	4.00 BSC		
Exposed Pad Width	E2	2.45	2.50	2.55
Overall Length	D	4.00 BSC		
Exposed Pad Length	D2	2.45	2.50	2.55
Terminal Width	b	0.20	0.25	0.30
Terminal Length	L	0.35	0.40	0.45
Terminal-to-Exposed-Pad	K	0.20	-	-

**Notes:**

1. Pin 1 visual index feature may vary, but must be located within the hatched area.
2. Package is saw singulated
3. Dimensioning and tolerancing per ASME Y14.5M

BSC: Basic Dimension. Theoretically exact value shown without tolerances.

REF: Reference Dimension, usually without tolerance, for information purposes only.



**MICROCHIP**

---

---

**Package Outlines and Dimensions**

---

---

**NOTES:**



---

---

**Package Outlines and Dimensions**

---

---

**VQFN**

SST Legacy

**Package Outlines and Dimensions**

**16-Lead Very Thin Quad Flatpack No-Leads (QVCE/F) - 3x3 mm Body [VQFN]**

**Note:** For the most current package drawings, please see the Microchip Packaging Specification located at <http://www.microchip.com/packaging>

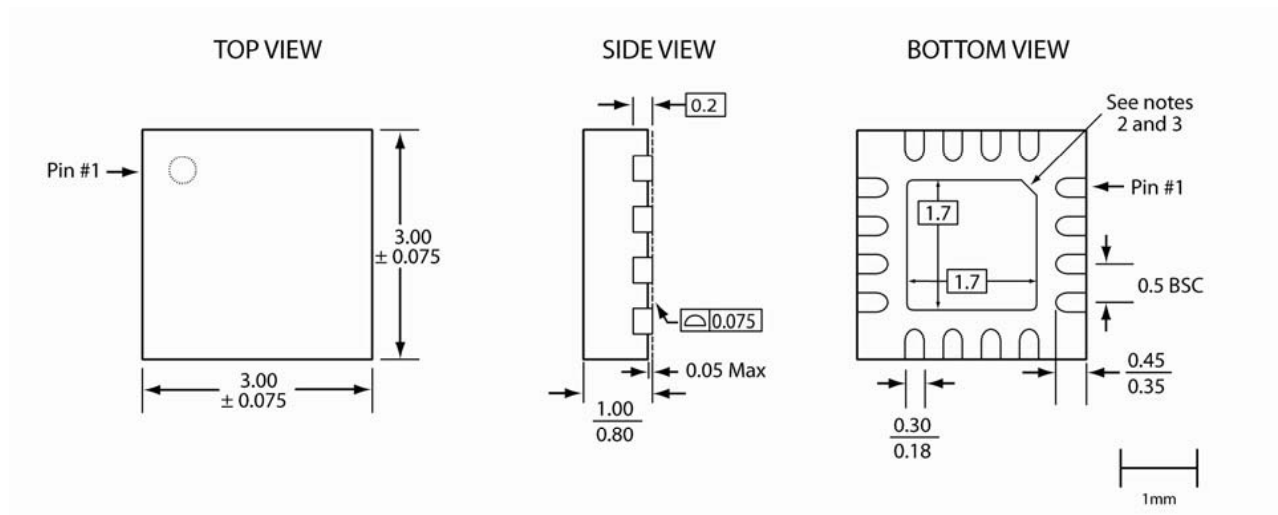

16-vqfn-3x3-QVC-2.0

**Note:**

1. Complies with JEDEC JEP95 MO-220J, variant VEED-4 except external paddle nominal dimensions.
2. From the bottom view, the pin #1 indicator may be either a 45-degree chamfer or a half-circle notch.
3. The external paddle is electrically connected to the die back-side and possibly to certain VSS leads. This paddle can be soldered to the PC board; it is suggested to connect this paddle to the VSS of the unit. Connection of this paddle to any other voltage potential can result in shorts and/or electrical malfunction of the device.
4. Untoleranced dimensions are nominal target dimensions.
5. All linear dimensions are in millimeters (max/min).

---

---

**Package Outlines and Dimensions**

---

---

**XQFN**

SST Legacy

**Package Outlines and Dimensions**

**12-Lead Extremely Thin Quad Flatpack No-Leads (QXBE/F) - 2x2 mm Body [XQFN]**

**Note:** For the most current package drawings, please see the Microchip Packaging Specification located at <http://www.microchip.com/packaging>

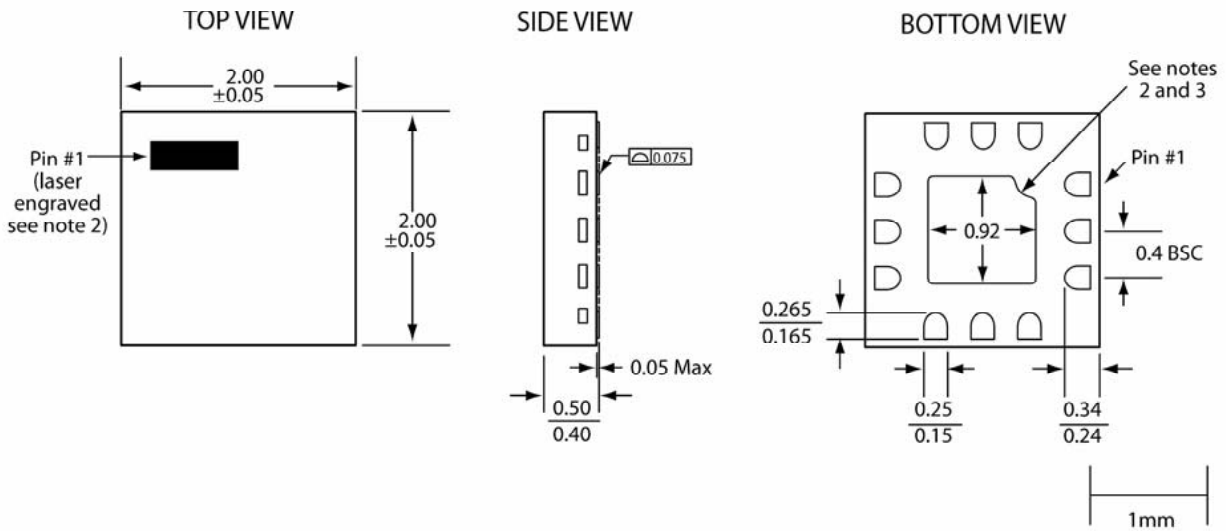

12-xqfn-2x2-QXB-2.0

**Note:**

1. Complies with JEDEC JEP95 MO-220J, variant VEED-4 except external paddle nominal dimensions and pull-back of terminals from body edge.
2. The topside pin #1 indicator is laser engraved; its approximate shape and location is as shown.
3. From the bottom view, the pin #1 indicator may be either a curved indent or a 45-degree chamfer.
4. The external paddle is electrically connected to the die back-side and possibly to certain VSS leads. This paddle must be soldered to the PC board; it is required to connect this paddle to the VSS of the unit. Connection of this paddle to any other voltage potential will result in shorts and electrical malfunction of the device.
5. Untoleranced dimensions are nominal target dimensions.
6. All linear dimensions are in millimeters (max/min).

---



---

## Package Outlines and Dimensions

---



---

### 16-Lead Extremely Thin Quad Flatpack No-Leads (QXCE/F) - 3x3 mm Body [XQFN]

**Note:** For the most current package drawings, please see the Microchip Packaging Specification located at <http://www.microchip.com/packaging>

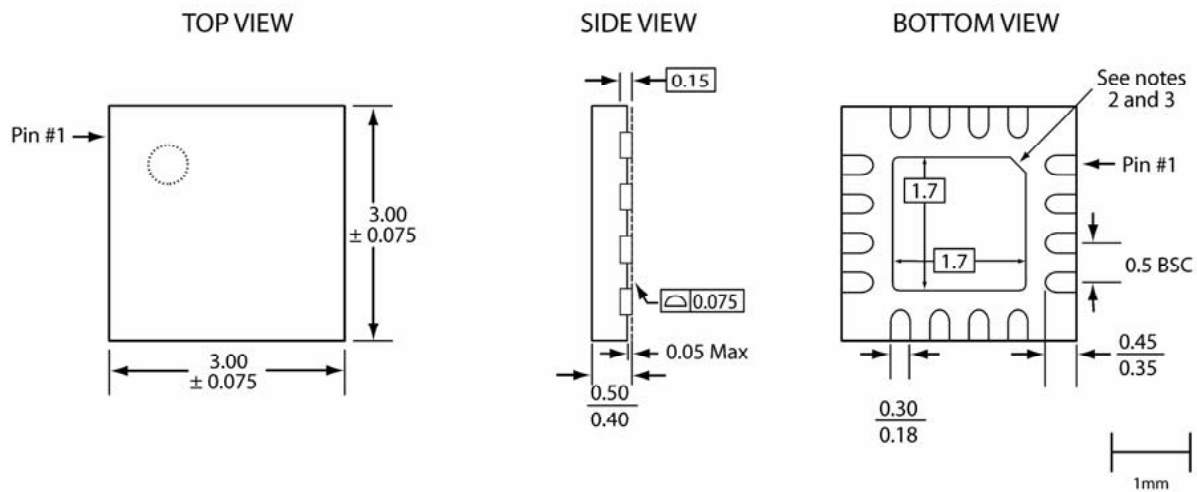

16-xqfn-3x3-QXC-1.0

**Note:**

1. Complies with JEDEC JEP95 MO-248, variant XEED-4 except external paddle nominal dimensions.
2. From the bottom view, the pin #1 indicator may be either a 45-degree chamfer or a half-circle notch.
3. The external paddle is electrically connected to the die back-side and to VSS.  
This paddle must be soldered to the PC board; it is required to connect this paddle to the VSS of the unit.  
Connection of this paddle to any other voltage potential will result in shorts and electrical malfunction of the device.
4. Untoleranced dimensions are nominal target dimensions.
5. All linear dimensions are in millimeters (max/min).



**MICROCHIP**

---

---

**Package Outlines and Dimensions**

---

---

**NOTES:**

---

---

**Package Outlines and Dimensions**

---

---

**X2QFN**  
SST Legacy

**Package Outlines and Dimensions**

**16-Lead Super-Thin Quad Flatpack No-Leads (Q3CE/F) - 2.5x2.5 mm Body [X2QFN]**

**Note:** For the most current package drawings, please see the Microchip Packaging Specification located at <http://www.microchip.com/packaging>

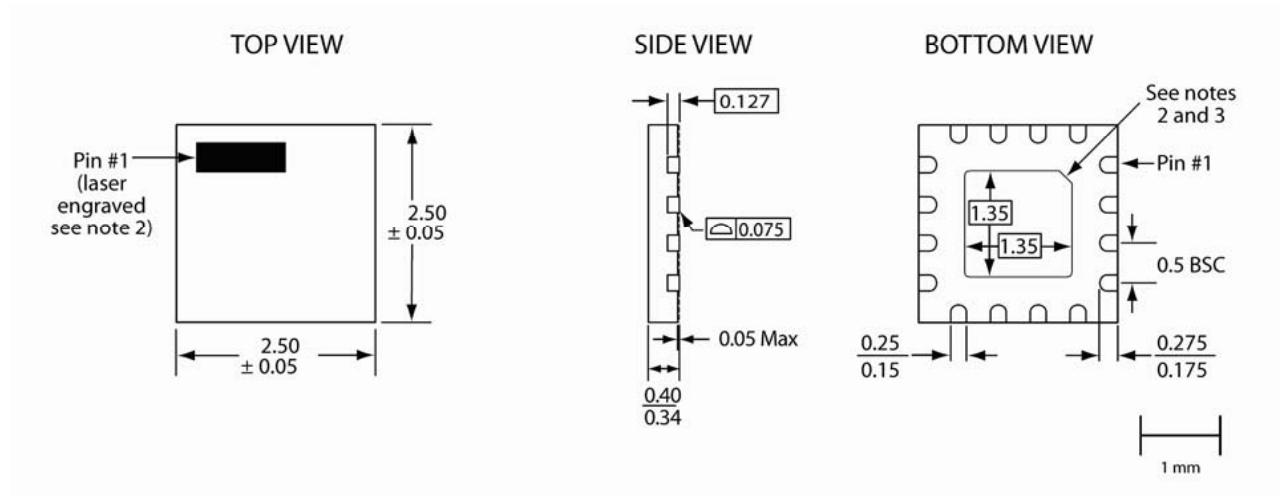

**Note:**

1. From the bottom view, the pin #1 indicator may be either a 45-degree chamfer or a half-circle notch.
2. The topside pin #1 indicator is laser engraved; its approximate shape and location is as shown.
3. The external paddle is electrically connected to the die back-side and to VSS.  
This paddle must be soldered to the PC board; it is required to connect this paddle to the VSS of the unit.  
Connection of this paddle to any other voltage potential will result in shorts and electrical malfunction of the device.
4. Untoleranced dimensions are nominal target dimensions.
5. All linear dimensions are in millimeters (max/min).



---

---

**Package Outlines and Dimensions**

---

---

**WQFN**

SST Legacy

**Package Outlines and Dimensions**

**16-Lead Very, Very Thin Quad Flatpack No-Leads (QCE/F) - 3x3 mm Body [WQFN]**

**Note:** For the most current package drawings, please see the Microchip Packaging Specification located at <http://www.microchip.com/packaging>

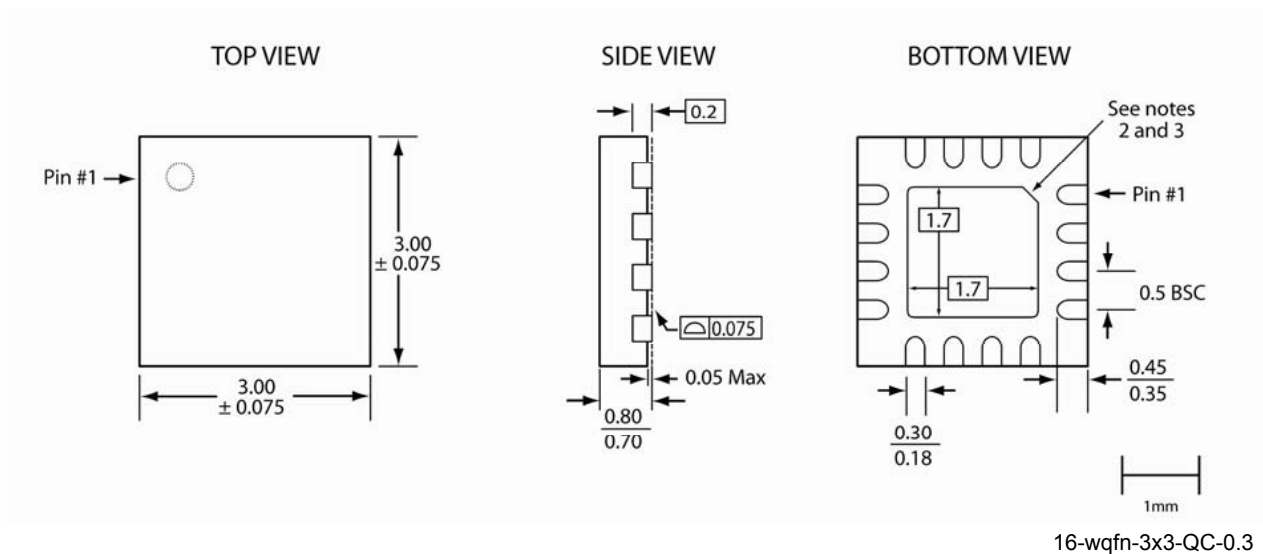

**Note:**

1. Complies with JEDEC JEP95 MO-220J, variant WEED-4 except external paddle nominal dimensions.
2. From the bottom view, the pin #1 indicator may be either a 45-degree chamfer or a half-circle notch.
3. The external paddle is electrically connected to the die back-side and possibly to certain VSS leads.  
This paddle can be soldered to the PC board; it is suggested to connect this paddle to the VSS of the unit.  
Connection of this paddle to any other voltage potential can result in shorts and/or electrical malfunction of the device.
4. Untoleranced dimensions are nominal target dimensions.
5. All linear dimensions are in millimeters (max/min).

---



---

## Package Outlines and Dimensions

---



---

### 24-Lead Very, Very Thin Quad Flatpack No-Leads (QDE/F) - 4x4 mm Body [WQFN]

**Note:** For the most current package drawings, please see the Microchip Packaging Specification located at <http://www.microchip.com/packaging>

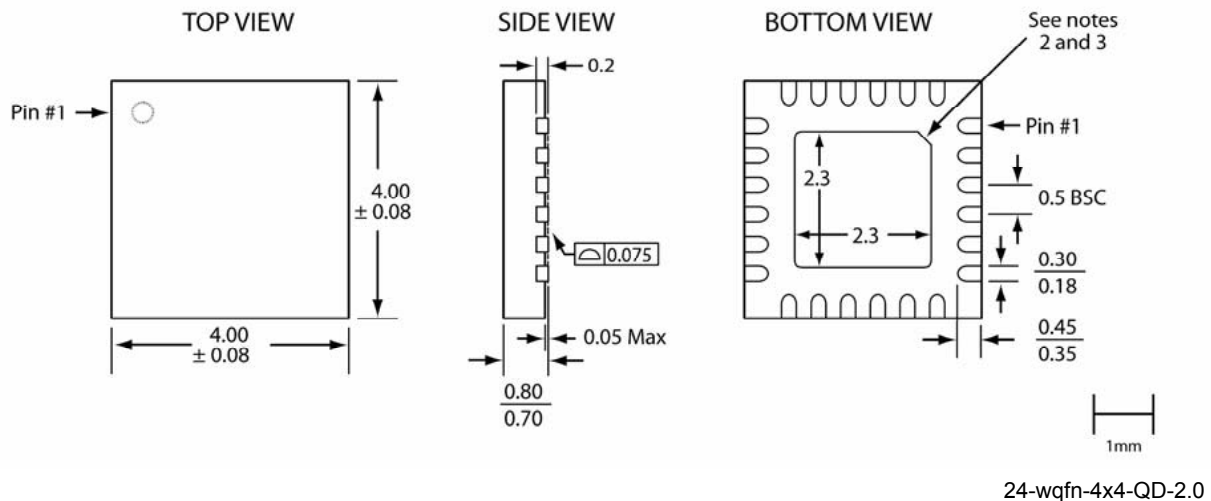

**Note:**

1. Complies with JEDEC JEP95 MO-220J, variant WGGD-4 except external paddle dimensions.
2. From the bottom view, the pin #1 indicator may be either a 45-degree chamfer or a half-circle notch.
3. The external paddle is electrically connected to the die back-side and possibly to certain VSS leads. This paddle can be soldered to the PC board; it is suggested to connect this paddle to the VSS of the unit. Connection of this paddle to any other voltage potential can result in shorts and/or electrical malfunction of the device.
4. Untoleranced dimensions are nominal target dimensions.
5. All linear dimensions are in millimeters (max/min).

**Package Outlines and Dimensions**

**40-Lead Very, Very Thin Quad Flatpack No-Leads (QIE/F) - 6x6 mm Body [WQFN]**

**Note:** For the most current package drawings, please see the Microchip Packaging Specification located at <http://www.microchip.com/packaging>

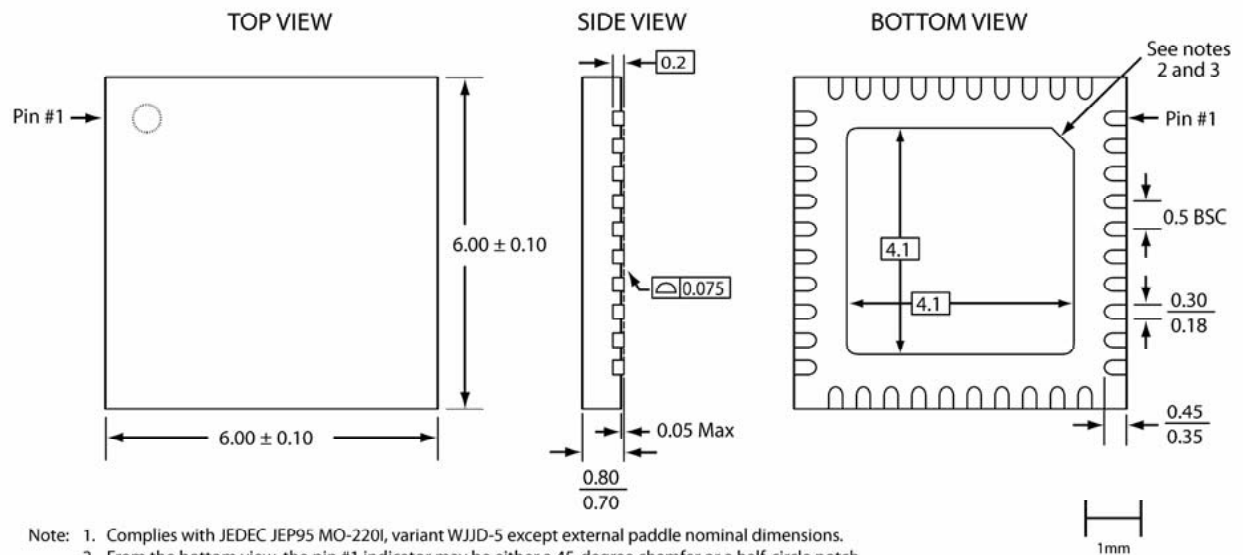

- Note: 1. Complies with JEDEC JEP95 MO-220I, variant WJJD-5 except external paddle nominal dimensions.  
 2. From the bottom view, the pin #1 indicator may be either a 45-degree chamfer or a half-circle notch.  
 3. The external paddle is electrically connected to the die back-side and possibly to certain V<sub>SS</sub> leads. This paddle should be soldered to the PC board; it is suggested to connect this paddle to the V<sub>SS</sub> of the unit. Connection of this paddle to any other voltage potential will result in shorts and/or electrical malfunction of the device.  
 4. Untoleranced dimensions are nominal target dimensions.  
 5. All linear dimensions are in millimeters (max/min).

40-wqfn-6x6-QI-1

---

---

**Package Outlines and Dimensions**

---

---

**USON**

SST Legacy

**Package Outlines and Dimensions**

**8-Lead Ultra Thin Small Outline No-Leads (QU8E/F) - 2x2 mm Body [USON]**

**Note:** For the most current package drawings, please see the Microchip Packaging Specification located at <http://www.microchip.com/packaging>

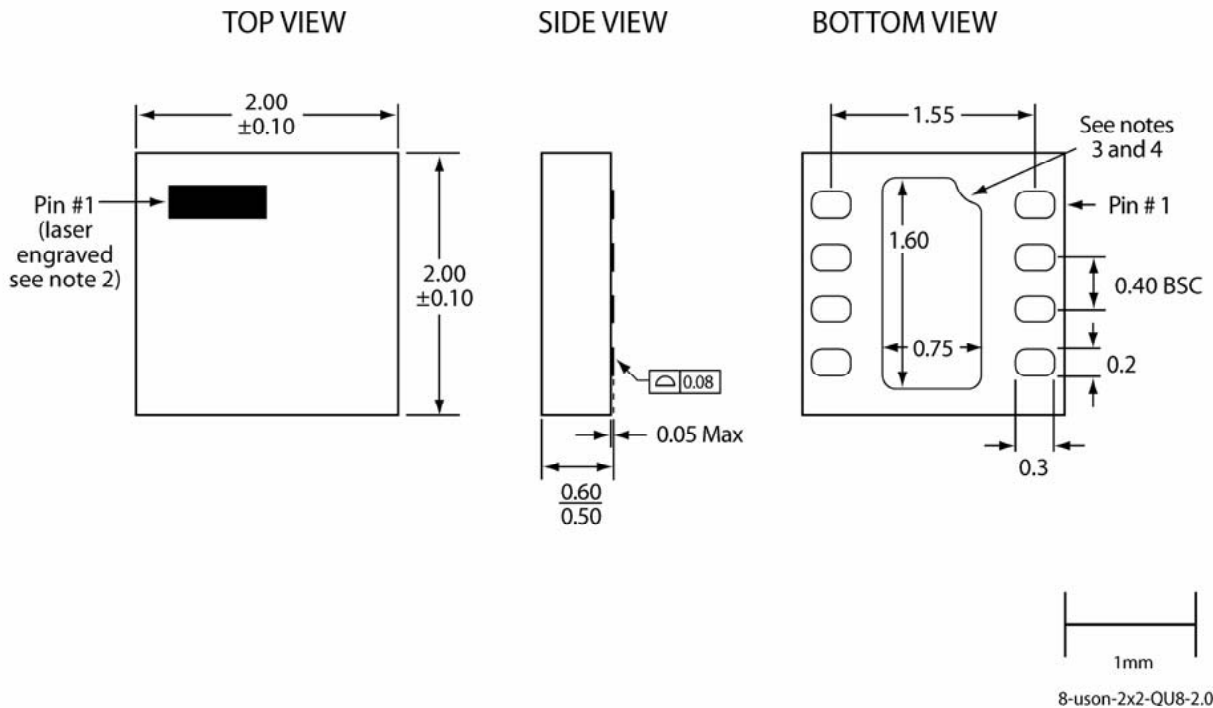

**Note:**

1. Similar to JEDEC JEP95 XQFN/XSON variants, though number of contacts and some dimensions are different.
2. The topside pin #1 indicator is laser engraved; its approximate shape and location is as shown.
3. From the bottom view, the pin #1 indicator may be either a curved indent or a 45-degree chamfer.
4. The external paddle is electrically connected to the die back-side and to VSS.  
This paddle must be soldered to the PC board; it is required to connect this paddle to the VSS of the unit.  
Connection of this paddle to any other voltage potential will result in shorts and electrical malfunction of the device.
5. Untoleranced dimensions are nominal target dimensions.
6. All linear dimensions are in millimeters (max/min).

---



---

## Package Outlines and Dimensions

---



---

### 8-Lead Ultra Thin Small Outline No-Leads (QUAE/F) - 2x2 mm Body [USON]

**Note:** For the most current package drawings, please see the Microchip Packaging Specification located at <http://www.microchip.com/packaging>

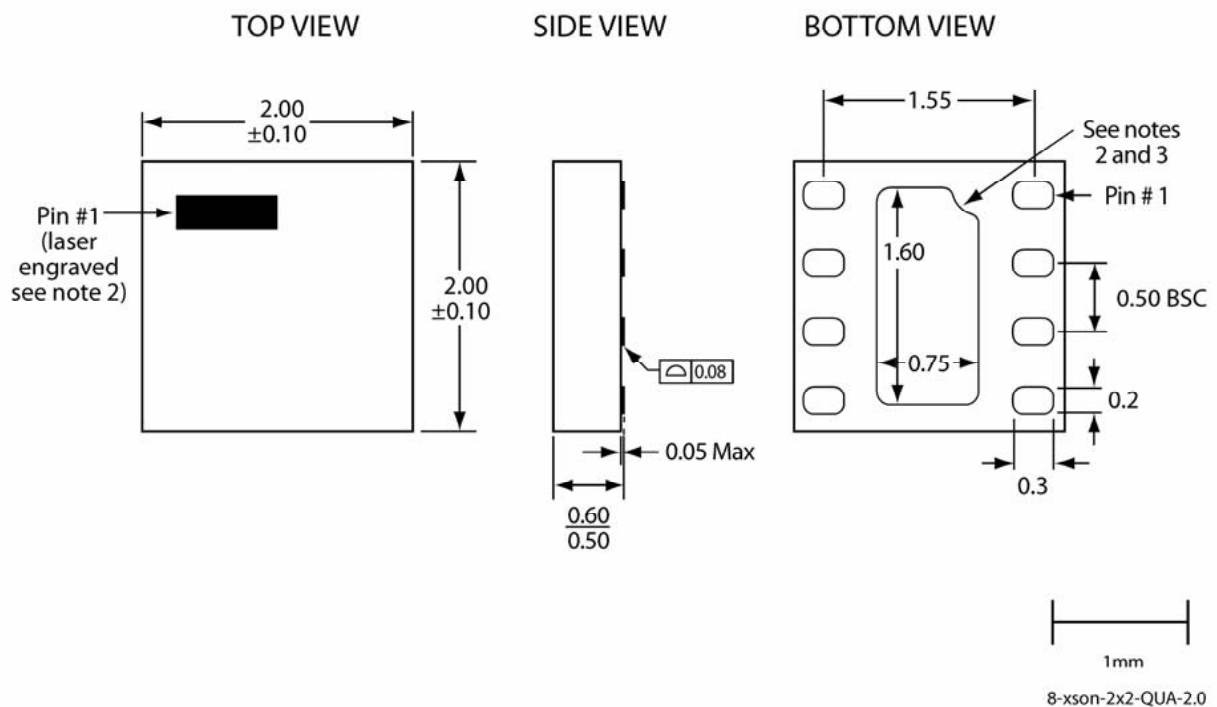

**Note:**

1. Similar to JEDEC JEP95 UQFN/USON variants, though number of contacts and some dimensions are different.
2. The topside pin #1 indicator is laser engraved; its approximate shape and location is as shown.
3. The external paddle is electrically connected to the die back-side and to VSS.  
This paddle must be soldered to the PC board; it is required to connect this paddle to the VSS of the unit.  
Connection of this paddle to any other voltage potential will result in shorts and electrical malfunction of the device.
4. Untoleranced dimensions are nominal target dimensions.
5. All linear dimensions are in millimeters (max/min).



**MICROCHIP**

---

---

**Package Outlines and Dimensions**

---

---

**NOTES:**



---

---

**Package Outlines and Dimensions**

---

---

**WSON**

SST Legacy

**Package Outlines and Dimensions**

**8-Lead Very, Very Thin Small Outline No-Leads (QAE/F) - 5x6 mm Body [WSON]**

**Note:** For the most current package drawings, please see the Microchip Packaging Specification located at <http://www.microchip.com/packaging>

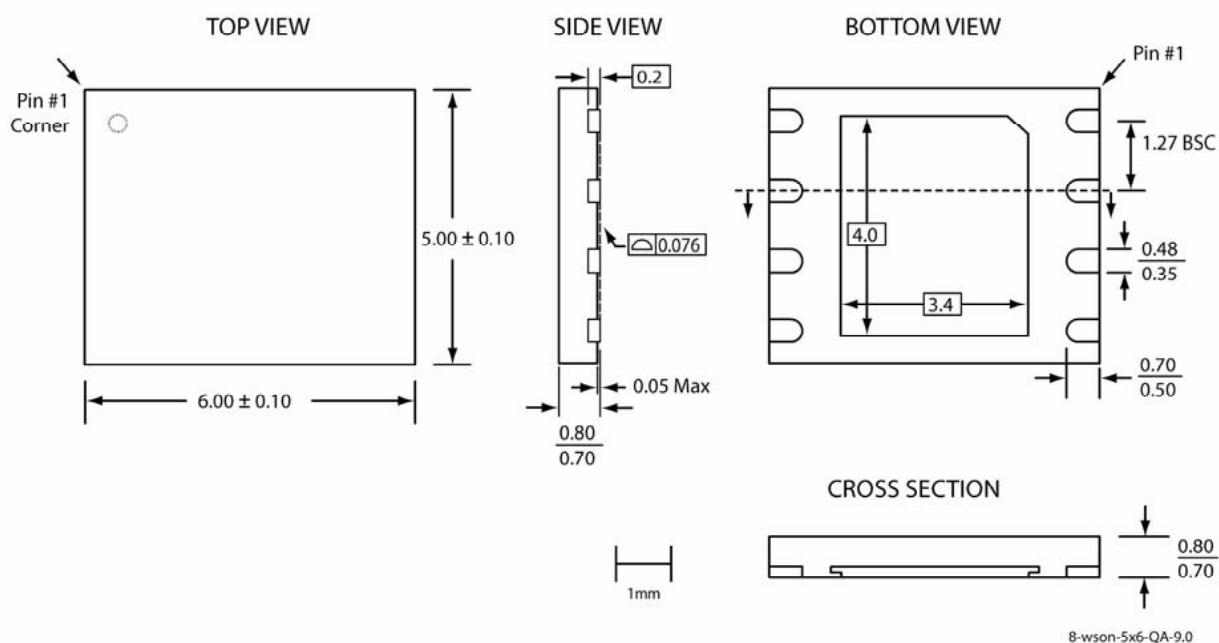

**Note:**

1. All linear dimensions are in millimeters (max/min).
2. Untoleranced dimensions (shown with box surround) are nominal target dimensions.
3. The external paddle is electrically connected to the die back-side and possibly to certain VSS leads. This paddle can be soldered to the PC board; it is suggested to connect this paddle to the VSS of the unit. Connection of this paddle to any other voltage potential can result in shorts and/or electrical malfunction of the device.

---



---

## Package Outlines and Dimensions

---



---

### 8-Lead Very, Very Thin Small Outline No-Leads (Q2AE/F) - 6x8 mm Body [WSO]

**Note:** For the most current package drawings, please see the Microchip Packaging Specification located at <http://www.microchip.com/packaging>

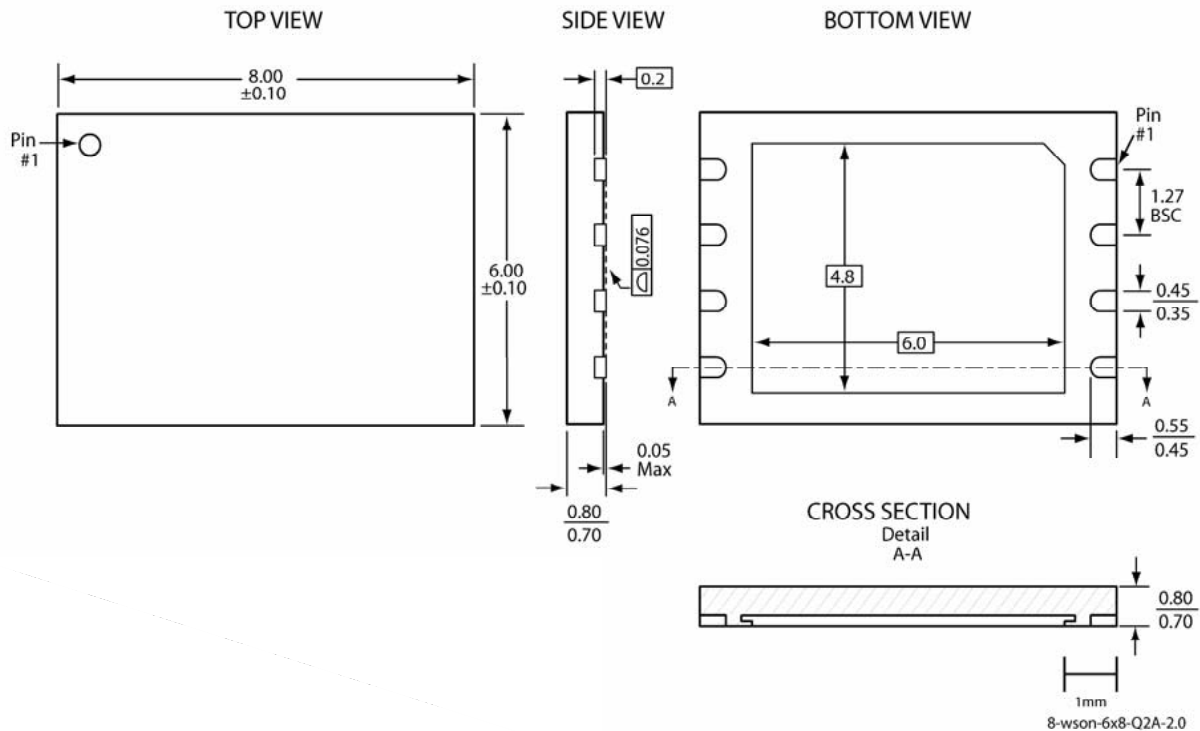

**Note:**

1. All linear dimensions are in millimeters (max/min).
2. Untoleranced dimensions are nominal target dimensions.
3. The external paddle is electrically connected to die back-side and VSS.  
This paddle can be soldered to the PC board;  
SST suggests connecting this paddle to VSS of the unit.  
Connection of this paddle to any other voltage potential will result in shorts and/or electrical malfunction of the device.



**MICROCHIP**

---

---

**Package Outlines and Dimensions**

---

---

NOTES:

---

---

**Package Outlines and Dimensions**

---

---

**XSON**

SST Legacy

**Package Outlines and Dimensions**

**6-Lead Extremely Thin Small Outline No-Leads (QX6E/F) - 1.5x1.5 mm Body [XSON]**

**Note:** For the most current package drawings, please see the Microchip Packaging Specification located at <http://www.microchip.com/packaging>

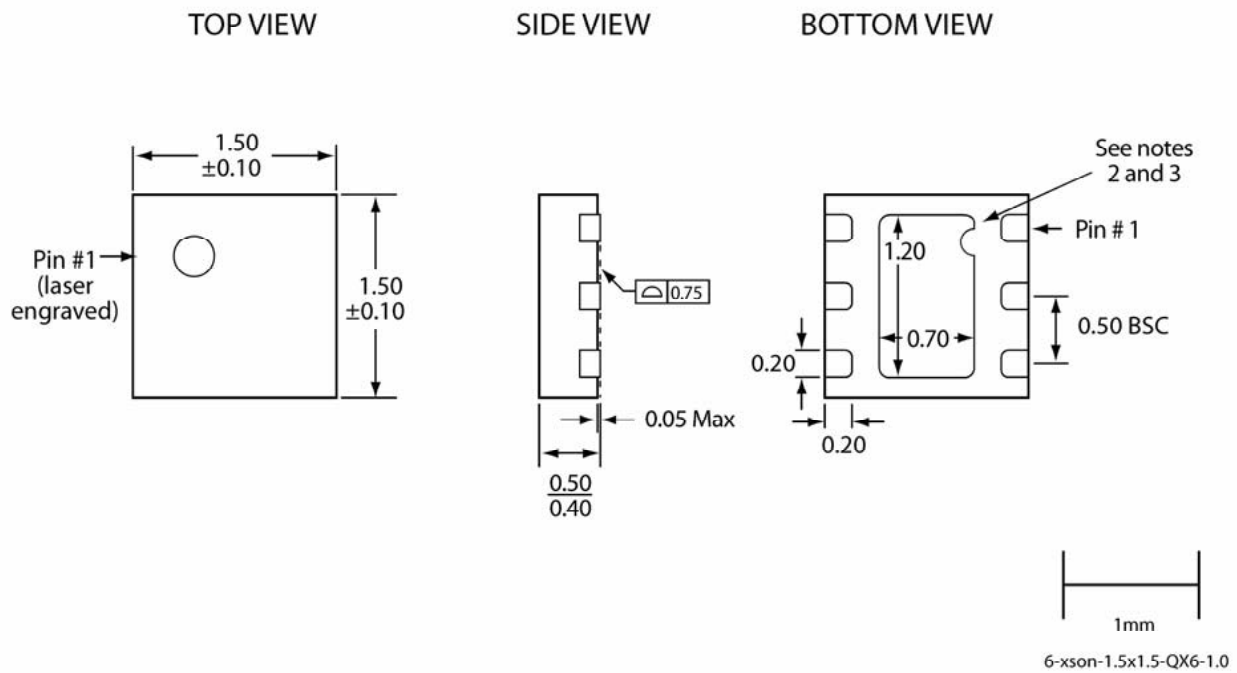

**Note:**

1. Similar to JEDEC JEP95 XQFN/XSON variants, though number of contacts and some dimensions are different.
2. From the bottom view, the pin #1 indicator may be either a curved indent or a 45-degree chamfer.
3. The external paddle is electrically connected to the die back-side and to VSS.  
This paddle must be soldered to the PC board; it is required to connect this paddle to the VSS of the unit.  
Connection of this paddle to any other voltage potential will result in shorts and electrical malfunction of the device.
4. Untoleranced dimensions are nominal target dimensions.
5. All linear dimensions are in millimeters (max/min).

---



---

## Package Outlines and Dimensions

---



---

### 8-Lead Extremely Thin Small Outline No-Leads (QX8E/F) - 2x2 mm Body [XSON]

**Note:** For the most current package drawings, please see the Microchip Packaging Specification located at <http://www.microchip.com/packaging>

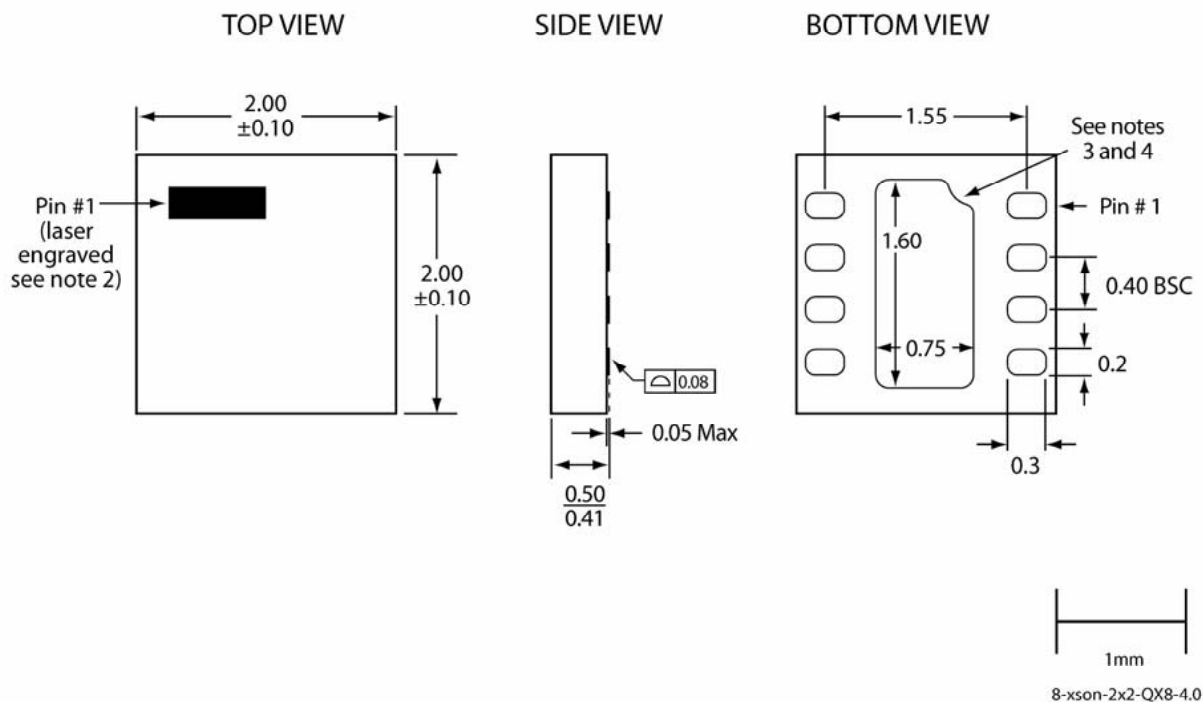

**Note:**

1. Similar to JEDEC JEP95 XQFN/XSON variants, though number of contacts and some dimensions are different.
2. The topside pin #1 indicator is laser engraved; its approximate shape and location is as shown.
3. From the bottom view, the pin #1 indicator may be either a curved indent or a 45-degree chamfer.
4. The external paddle is electrically connected to the die back-side and to VSS.  
This paddle must be soldered to the PC board; it is required to connect this paddle to the VSS of the unit.  
Connection of this paddle to any other voltage potential will result in shorts and electrical malfunction of the device.
5. Untoleranced dimensions are nominal target dimensions.
6. All linear dimensions are in millimeters (max/min).



**MICROCHIP**

---

---

**Package Outlines and Dimensions**

---

---

**NOTES:**



---

---

**Legacy SMSC Packaging Outlines and Dimensions**

---

---

**Legacy SMSC Package Drawings & Specifications**



**MICROCHIP**

---

---

**Legacy SMSC Packaging Outlines and Dimensions**

---

---

---

---

## Legacy SMSC Packaging Outlines and Dimensions

---

---

### **DFN**

SMSC Legacy

## Legacy SMSC Packaging Outlines and Dimensions

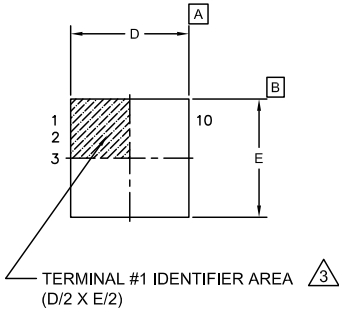

TOP VIEW

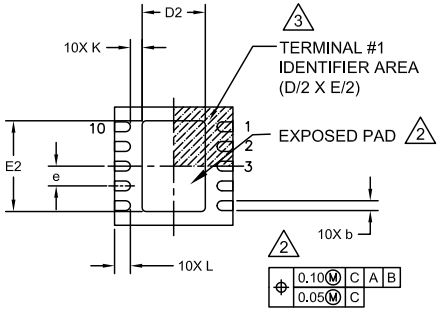

BOTTOM VIEW

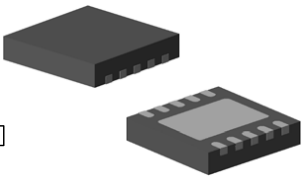

3-D VIEWS

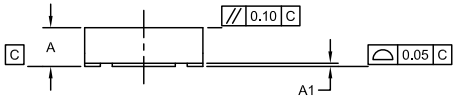

SIDE VIEW

COMMON DIMENSIONS					
SYMBOL	MIN	NOM	MAX	NOTE	REMARK
A	0.80	0.85	0.90	-	OVERALL PACKAGE HEIGHT
A1	0	0.02	0.05	-	STANDOFF
D/E	2.90	3.00	3.10	-	X/Y BODY SIZE
D2	1.50	1.60	1.70	2	X EXPOSED PAD SIZE
E2	2.20	2.30	2.40	2	Y EXPOSED PAD SIZE
L	0.35	0.40	0.45	-	TERMINAL LENGTH
b	0.18	0.25	0.30	2	TERMINAL WIDTH
K	0.25	0.30	-	-	TERMINAL TO PAD DISTANCE
e	0.50 BSC		-	-	TERMINAL PITCH

REVISION HISTORY					
REV	DESCRIPTION	DATE	RELEASED BY		
A	INITIAL PRELIMINARY RELEASE	2/28/08	S.K.ILIEV		
B	ADDED PAGE 2of2. APPLICATION NOTES UPDATED	4/8/09	S.K.ILIEV		

COMMON DIMENSIONS					
SYMBOL	MIN	NOM	MAX	NOTE	REMARK
A	0.80	0.85	0.90	-	OVERALL PACKAGE HEIGHT
A1	0	0.02	0.05	-	STANDOFF
D/E	2.90	3.00	3.10	-	X/Y BODY SIZE
D2	1.50	1.60	1.70	2	X EXPOSED PAD SIZE
E2	2.20	2.30	2.40	2	Y EXPOSED PAD SIZE
L	0.35	0.40	0.45	-	TERMINAL LENGTH
b	0.18	0.25	0.30	2	TERMINAL WIDTH
K	0.25	0.30	-	-	TERMINAL TO PAD DISTANCE
e	0.50 BSC		-	-	TERMINAL PITCH

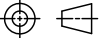
<p>UNLESS OTHERWISE SPECIFIED DIMENSIONS ARE IN MILLIMETERS AND TOLERANCES ARE:</p> <p>DECIMAL X.X ±0.1 X.XX ±0.05 X.XXX ±0.025</p> <p>INTERPRET DIM AND TOL PER ASME Y14.5M - 1994</p>	<p>THIRD ANGLE PROJECTION</p> 	<p>Note: For the most current package drawings, see the Microchip Packaging Specification at <a href="http://www.microchip.com/packaging">http://www.microchip.com/packaging</a></p>
<p>MATERIAL -</p>	<p>NAME -</p>	<p>TITLE <b>PACKAGE DATA</b> 10 PINS DFN-162304, 3x3mm BODY, 0.50mm PITCH 1.6x2.3mm ePAD, FULL LEAD DESIGN (SAWN) <b>Package Outline Drawing</b></p>
<p>FINISH -</p>	<p>CHECKED S.K.ILIEV</p>	<p>DWG NUMBER 10DFN-162304-3x3B</p>
<p>PRINT WITH "SCALE TO FIT" DO NOT SCALE DRAWING</p>	<p>APPROVED S.K.ILIEV</p>	<p>SCALE 1:1</p> <p>STD COMPLIANCE MO-229</p> <p>REV B</p> <p>SHEET 1 OF 2</p>

**NOTES:**

- ALL DIMENSIONS ARE IN MILLIMETERS.
- UNILATERAL COPLANARITY ZONE APPLIES TO THE EXPOSED PAD, AS WELL AS THE TERMINALS. DIMENSIONS "b" APPLIES TO PLATED TERMINALS AND IT IS MEASURED BETWEEN 0.15 AND 0.30 mm FROM THE TERMINAL TIP.
- DETAILS OF TERMINAL #1 IDENTIFIER ARE OPTIONAL BUT MUST BE LOCATED WITHIN THE AREA INDICATED.

## Legacy SMSC Packaging Outlines and Dimensions

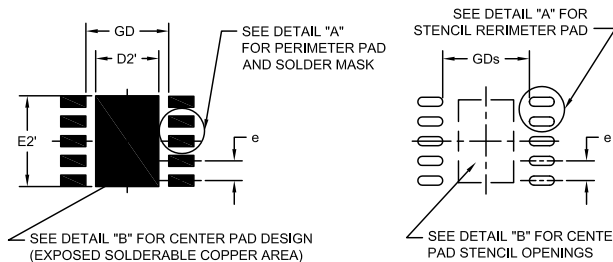

**PCB LAND PATTERN**

**STENCIL**

REVISION HISTORY			
REV	DESCRIPTION	DATE	RELEASED BY
B	ADDED PAGE 2 of 2. APPLICATION NOTES UPDATED	4/8/09	S.K.ILIEV

  

LAND PATTERN DIMENSIONS			
SYMBOL	MIN	NOM	MAX
GD	2.10	-	2.20
GDs	2.20	-	-
D2'	-	1.60	1.60
E2'	-	2.30	-
Pad: X	-	0.28	0.28
Stencil: Xs	-	0.23	0.25
Pad: Y	-	0.69	0.69
Stencil: Ys	-	0.62	0.64
e	0.50		

**SMT APPLICATION NOTES**

1. THE USER MAY MODIFY THE PCB LAND PATTERN DIMENSIONS BASED ON THEIR EXPERIENCE AND/OR PROCESS CAPABILITY.
2. THE LAND PATTERN CORRESPONDING TO THE PACKAGE EXPOSED PAD (IN THE CENTER) CAN BE LARGER, AND WITH DIFFERENT SHAPE THAN THE EXPOSED PAD ON THE PACKAGE. HOWEVER, THE SOLDERABLE AREA, AS DEFINED BY THE SOLDER MASK (SMD), OR NON SOLDER MASK DEFINED (NSMD), SHOULD BE AS SHOWN FOR THE BEST THERMAL & ELECTRICAL PERFORMANCE.
3. MAXIMUM THERMAL AND ELECTRICAL PERFORMANCE IS ACHIEVED WHEN AN ARRAY OF SOLID VIAS IS INCORPORATED IN THE CENTER LAND PATTERN (See Options 1 & 2).
4. THE VIAS SHOULD BE AT 0.8 to 1.2MM PITCH WITH 0.30 to 0.40MM DIAMETER, AND 1 OZ COPPER VIA BARREL PLATING.
5. NON SOLDER MASK DEFINED (NSMD) PAD DESIGN IS RECOMMENDED FOR PERIMETER LANDS.
6. A LASER-CUT STAINLESS STEEL STENCIL IS RECOMMENDED WITH ELECTRO POLISHED TRAPEZOIDAL WALLS. THE RECOMMENDED STENCIL THICKNESS IS 0.125 mm FOR PITCHES 0.4 and 0.5 mm.
7. RECOMMENDED STENCIL AREA & ASPECT RATIOS ARE 0.66 & 1.5 (MIN) RESPECTIVELY.
8. RECOMMENDED STENCIL APERTURES ARE AS SHOWN.
9. IT IS RECOMMENDED TO USE "NO-CLEAN", TYPE 3 SOLDER PASTE.
10. THE REFLOW PROFILE DEPENDS ON THE EXACT SOLDER PASTE USED AND THE GIVEN BOARD DETAILS, SUCH AS GEOMETRY, COMPONENTS ETC.

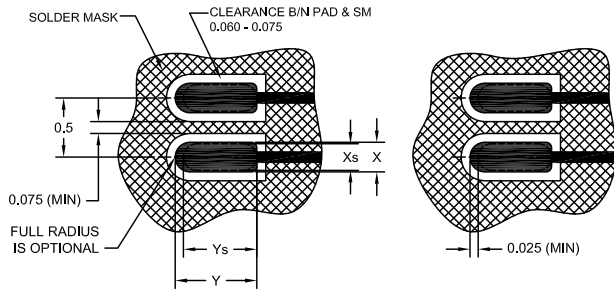

**DETAIL "A"**

**STENCIL OPENING - PERIMETER LANDS**

**OPTION 1**  
(NON-PLUGGED THERMAL VIAS)

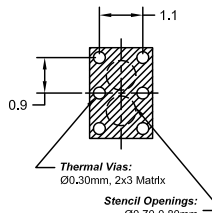

**Thermal Vias:**  
Ø0.30mm, 2x3 Matrix

**Stencil Openings:**  
Ø0.70-0.80mm

**OPTION 2**  
(PLUGGED THERMAL VIAS)

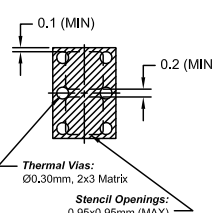

**Thermal Vias:**  
Ø0.30mm, 2x3 Matrix

**Stencil Openings:**  
0.95x0.95mm (MAX)

**DETAIL "B"**

**THERMAL VIAS and STENCIL OPENING - CENTER PAD**

<p>UNLESS OTHERWISE SPECIFIED DIMENSIONS ARE IN MILLIMETERS AND TOLERANCES ARE:</p> <p>DECIMAL XX ±0.1 X,XX ±0.05 X,XXX ±0.025</p> <p>INTERPRET DIM AND TOL PER ASME Y14.5M - 1994</p>	<p>THIRD ANGLE PROJECTION</p> 	<p>Note: For the most current package drawings, see the Microchip Packaging Specification at <a href="http://www.microchip.com/packaging">http://www.microchip.com/packaging</a></p>
<p>MATERIAL -</p>	<p>NAME -</p>	<p>TITLE <b>PACKAGE DATA</b> 10 PINS DFN-162304, 3x3mm BODY, 0.50mm PITCH 1.6x2.3mm ePAD, FULL LEAD DESIGN (SAWN) <b>Application Notes</b></p>
<p>FINISH -</p>	<p>CHECKED S.K.ILIEV</p>	<p>DWG NUMBER 10DFN-162304-3x3B</p>
<p>PRINT WITH "SCALE TO FIT" DO NOT SCALE DRAWING</p>	<p>APPROVED S.K.ILIEV</p>	<p>SCALE 1:1</p> <p>STD COMPLIANCE JEDEC: MO-229</p>
		<p>REV B</p> <p>SHEET 2 OF 2</p>



**MICROCHIP**

---

---

**Legacy SMSC Packaging Outlines and Dimensions**

---

---

**NOTES:**

---

---

## Legacy SMSC Packaging Outlines and Dimensions

---

---

### **DQFN Family**

SMSC Legacy

## Legacy SMSC Packaging Outlines and Dimensions

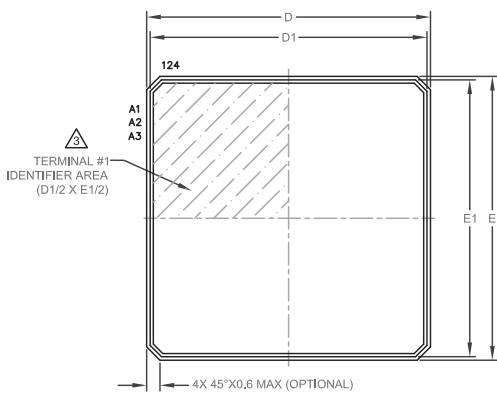

**TOP VIEW**

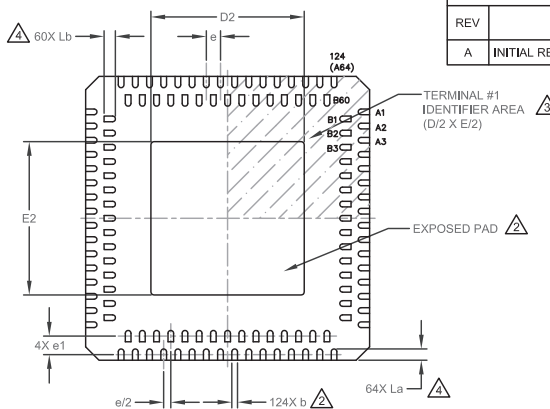

**BOTTOM VIEW**

REVISION HISTORY			
REV	DESCRIPTION	DATE	RELEASED BY
A	INITIAL RELEASE	12/12/07	S.K.ILIEV

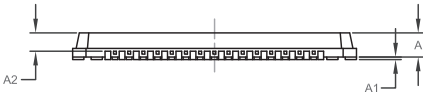

**SIDE VIEW**

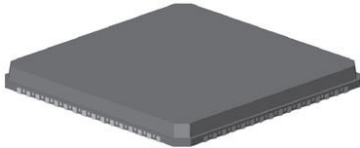

**3-D VIEW**

COMMON DIMENSIONS					
SYMBOL	MIN	NOM	MAX	NOTE	REMARK
A	-	0.80	0.85	-	OVERALL PKG HEIGHT
A1	0	0.01	0.05	-	STANDOFF
A2	-	0.65	0.70	-	MOLD THICKNESS
D/E	9.90	10.00	10.10	-	"X"/"Y" BODY SIZE
D1/E1	9.65	9.75	9.85	-	"X"/"Y" MOLD SIZE
D2/E2	5.30	5.40	5.50	2	"X"/"Y" EXPOSED PAD SIZE
La	0.30	0.40	0.50	4	OUTER TERMINAL LENGTH
Lb	0.30	0.40	0.50	4	INNER TERMINAL LENGTH
b	0.18	-	0.22	2	TERMINAL WIDTH
e	0.50 BSC		-	-	TERMINAL PITCH
e1	0.65 BSC		-	-	OUTER-INNER ROW DISTANCE

**NOTES:**

- ALL DIMENSIONS ARE IN MILLIMETER.
- POSITION TOLERANCE OF EACH TERMINAL AND EXPOSED PAD IS  $\pm 0.05\text{mm}$  AT MAXIMUM MATERIAL CONDITION. DIMENSIONS "b" APPLIES TO PLATED TERMINAL AND IS MEASURED BETWEEN 0.20 AND 0.25 mm FROM THE TERMINAL TIP.
- DETAILS OF TERMINAL #1 IDENTIFIER ARE OPTIONAL BUT MUST BE LOCATED WITHIN THE AREA INDICATED.
- ROUNDED INNER TIPS ON TERMINALS ARE OPTIONAL.

UNLESS OTHERWISE SPECIFIED DIMENSIONS ARE IN MILLIMETERS AND TOLERANCES ARE:

DECIMAL                      ANGULAR

XX      $\pm 0.1$                        $\pm 1^\circ$

XX      $\pm 0.05$

XXXX  $\pm 0.025$

INTERPRET DIM AND TOL PER ASME Y14.5M - 1994



THIRD ANGLE PROJECTION

Note: For the most current package drawings, see the Microchip Packaging Specification at <http://www.microchip.com/packaging>

TITLE		PACKAGE OUTLINE	
124 DQFN, 10x10 MM BODY, 0.5 MM PITCH		5.4x5.4 MM ePAD (PUNCHED)	
MATERIAL	DRAWN	DWG NUMBER	REV
-	S.K.ILIEV 12/10/07	AP-124-DQFN-10x10B-5.4x5.4ePAD	A
FINISH	CHECKED	SCALE	STD COMPLIANCE
-	S.K.ILIEV 12/10/07	1:1	-
PRINT WITH "SCALE TO FIT" DO NOT SCALE DRAWING	APPROVED	SHEET	1 OF 1
S.K.ILIEV 12/12/07			



## Legacy SMSC Packaging Outlines and Dimensions

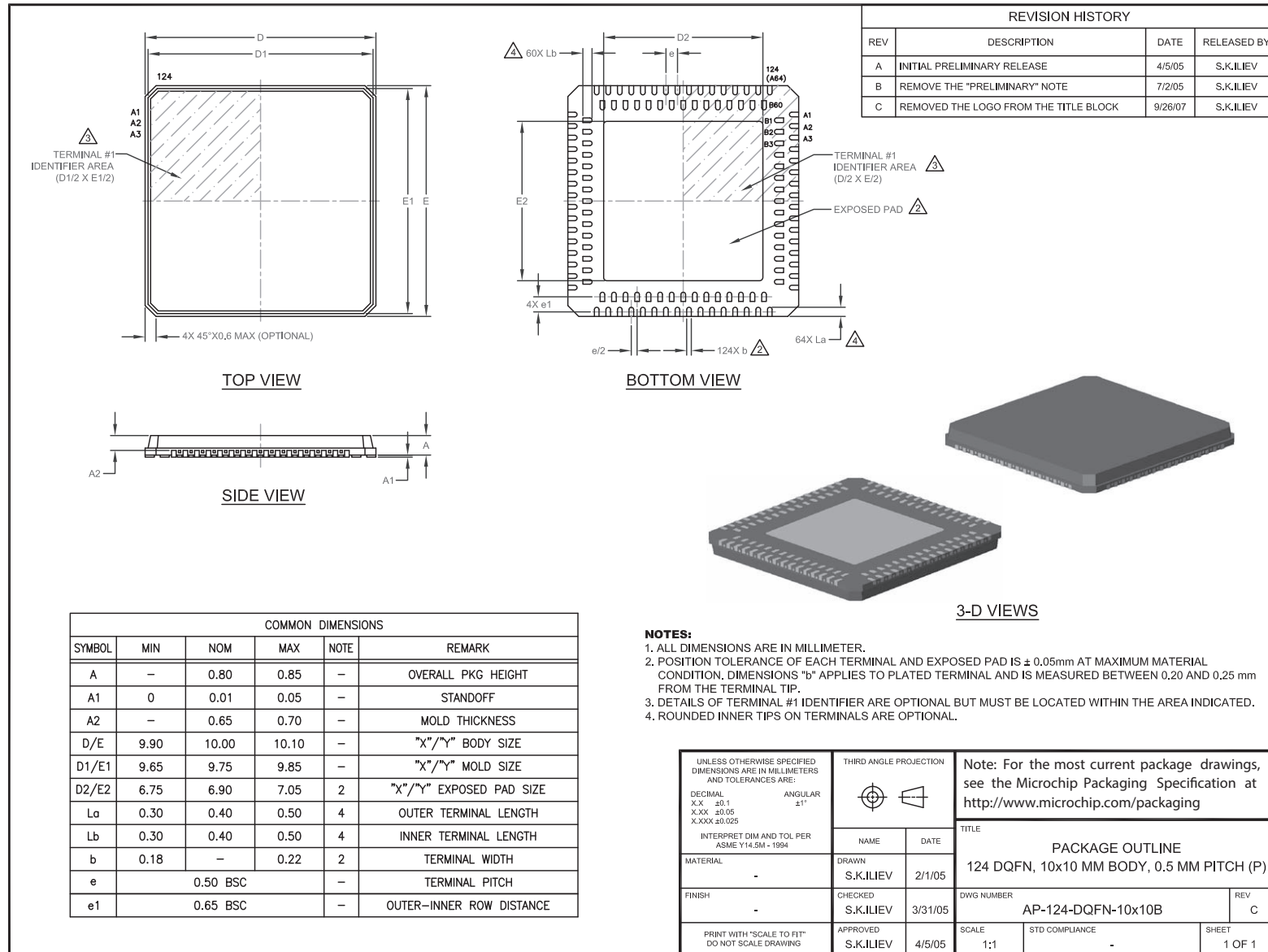

## Legacy SMSC Packaging Outlines and Dimensions

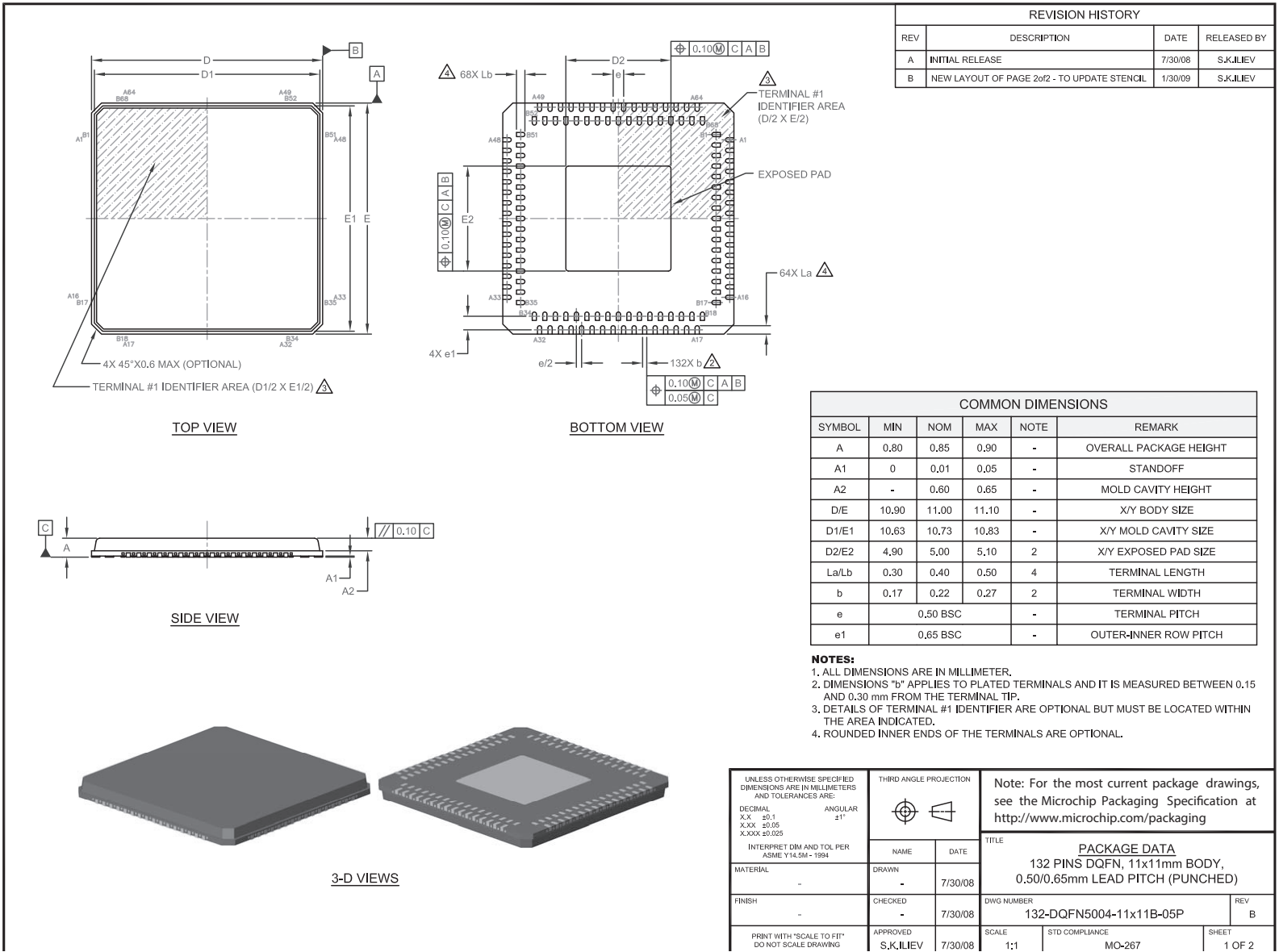

## Legacy SMSC Packaging Outlines and Dimensions

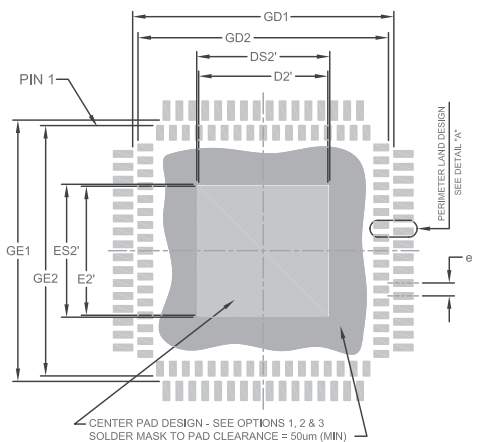

**PCB LAND PATTERN**

CENTER PAD DESIGN - SEE OPTIONS 1, 2 & 3  
SOLDER MASK TO PAD CLEARANCE = 50um (MIN)

REVISION HISTORY			
REV	DESCRIPTION	DATE	RELEASED BY
B	NEW LAYOUT OF PAGE 2of2 - TO UPDATE STENCIL	1/30/09	S.K.IJLIEV

LAND PATTERN DIMENSIONS		
SYMBOL	MIN	MAX
GD1/GE1	10.12	10.2
GD2/GE2	-	9.70
D2'/E2' (Copper center pad - NSMD)	-	5.00
DS2'/ES2' (Solder mask opening)	5.10	-
X	-	0.28
Y1	-	0.74
Y2	-	0.56
e	0.50	-

NSMD = Non Solder Mask Defined

  

**SMT APPLICATION NOTES**

1. THE USER MAY MODIFY THE PCB LAND PATTERN DIMENSIONS BASED ON THEIR EXPERIENCE AND/OR PROCESS CAPABILITY.
2. NON SOLDER MASK DEFINED (NSMD) CENTER LAND PATTERN (CORRESPONDING TO THE PACKAGE EXPOSED PAD) IS RECOMMENDED.
3. MAXIMUM THERMAL AND ELECTRICAL PERFORMANCE IS ACHIEVED WHEN AN ARRAY OF SOLID VIAS IS INCORPORATED IN THE CENTER LAND PATTERN. (See Options 1, 2 & 3)
4. THE VIAS SHOULD BE AT 0.8 TO 1.2MM PITCH WITH 0.30 TO 0.40MM DIAMETER, AND 1 OZ COPPER VIA BARREL PLATING.
5. NON SOLDER MASK DEFINED (NSMD) PAD DESIGN IS RECOMMENDED FOR PERIMETER LANDS.

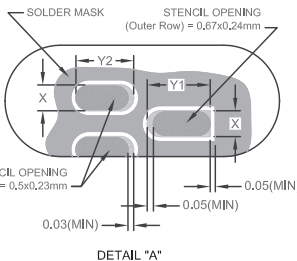
**DETAIL "A"**  
**STENCIL OPENING - PERIMETER LANDS**

**REWORK STENCIL OPENING - PERIMETER LANDS**  
**DIRECT SOLDER DEPOSIT ON PART**

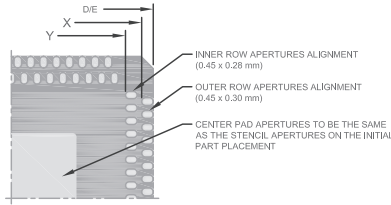

**OPTION 1**  
(UN-PLUGGED THERMAL VIAS)

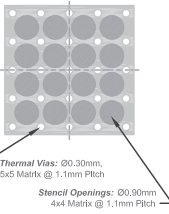

Thermal Vias: Ø0.30mm,  
5x5 Matrix @ 1.1mm Pitch  
Stencil Openings: Ø0.90mm  
4x4 Matrix @ 1.1mm Pitch

**OPTION 2**  
(PLUGGED THERMAL VIAS)

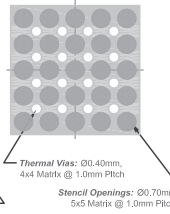

Thermal Vias: Ø0.40mm,  
4x4 Matrix @ 1.0mm Pitch  
Stencil Openings: Ø0.70mm,  
5x5 Matrix @ 1.0mm Pitch

**OPTION 3**  
(PLUGGED THERMAL VIAS)

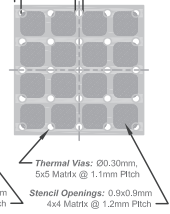

Thermal Vias: Ø0.30mm,  
5x5 Matrix @ 1.1mm Pitch  
Stencil Openings: Ø0.9x0.9mm  
4x4 Matrix @ 1.2mm Pitch

**THERMAL VIAS & STENCIL OPENING - CENTER PAD**

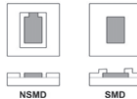

NSMD      SMD

6. A LASER-CUT STAINLESS STEEL STENCIL IS RECOMMENDED WITH ELECTRO POLISHED TRAPEZOIDAL WALLS. THE RECOMMENDED STENCIL THICKNESS IS 0.125 mm FOR PITCH = 0.5 mm.
7. RECOMMENDED STENCIL APERTURES ARE AS SHOWN.
8. IT IS RECOMMENDED TO USE "NO-CLEAN", TYPE 3 SOLDER PASTE.
9. THE REFLOW PROFILE DEPENDS ON THE EXACT SOLDER PASTE USED AND THE GIVEN BOARD DETAILS, SUCH AS GEOMETRY, COMPONENTS ETC.

  

UNLESS OTHERWISE SPECIFIED DIMENSIONS ARE IN MILLIMETERS AND TOLERANCES ARE:		THIRD ANGLE PROJECTION		Note: For the most current package drawings, see the Microchip Packaging Specification at <a href="http://www.microchip.com/packaging">http://www.microchip.com/packaging</a>
DECIMAL	ANGULAR			
X.X      ±0.1	±1°	NAME	DATE	<b>APPLICATION NOTES</b> 132 PINS DQFN, 11x11mm BODY, 0.50/0.65mm LEAD PITCH (PUNCHED)
X.XX    ±0.05		MATERIAL	DRAWN	
X.XXX ±0.025		FINISH	CHECKED	
INTERPRET DIM AND TOL PER ASME Y14.5M-1994	SCALE	APPROVED	DATE	
PRINT WITH "SCALE TO FIT" DO NOT SCALE DRAWING	1:1	S.K.IJLIEV	7/30/08	DWG NUMBER 132-DQFN5004-11x11B-05P
				TITLE 132 PINS DQFN, 11x11mm BODY, 0.50/0.65mm LEAD PITCH (PUNCHED)
				STD COMPLIANCE -
				SHEET 2 OF 2

## Legacy SMSC Packaging Outlines and Dimensions

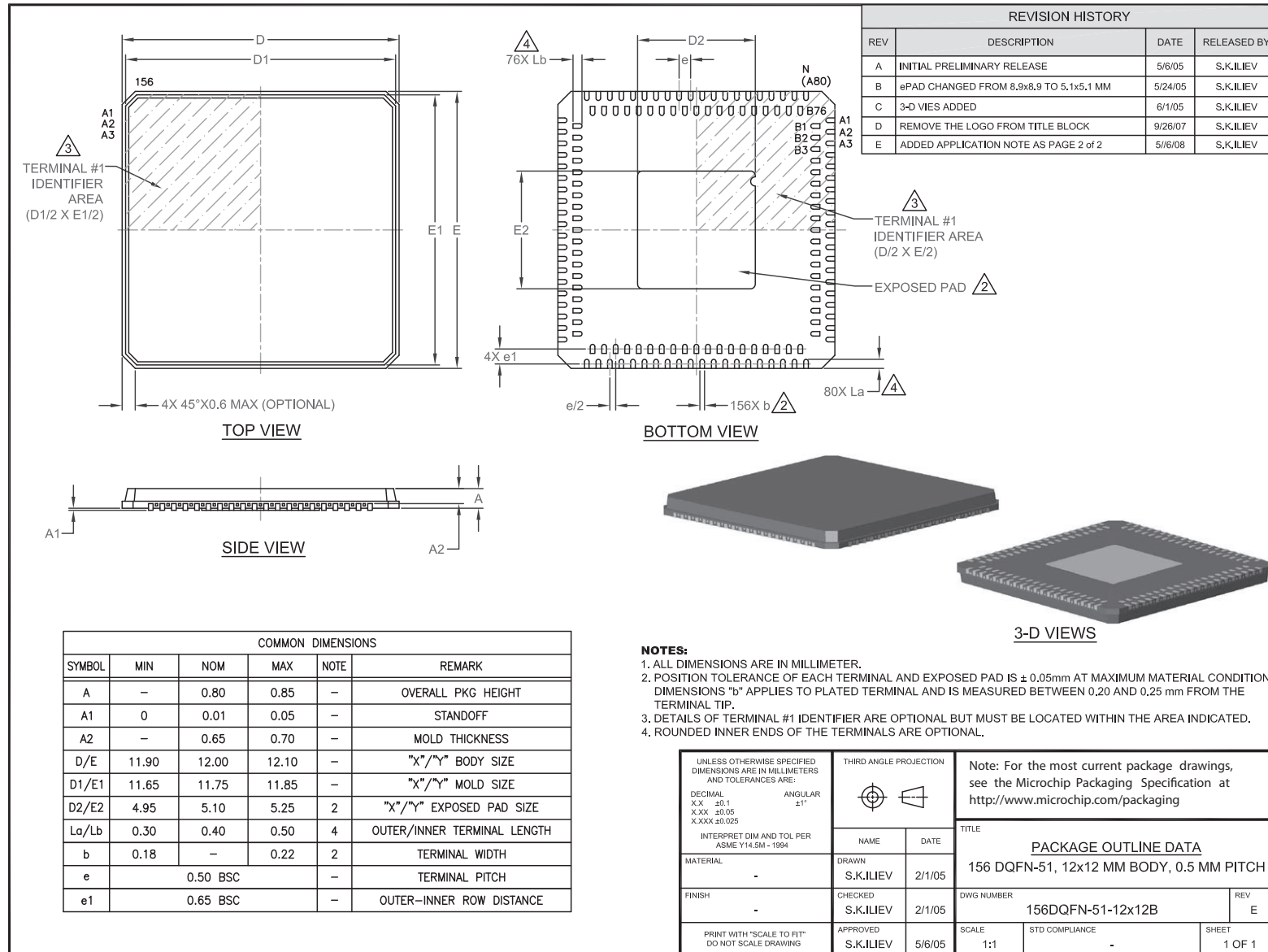

## Legacy SMSC Packaging Outlines and Dimensions

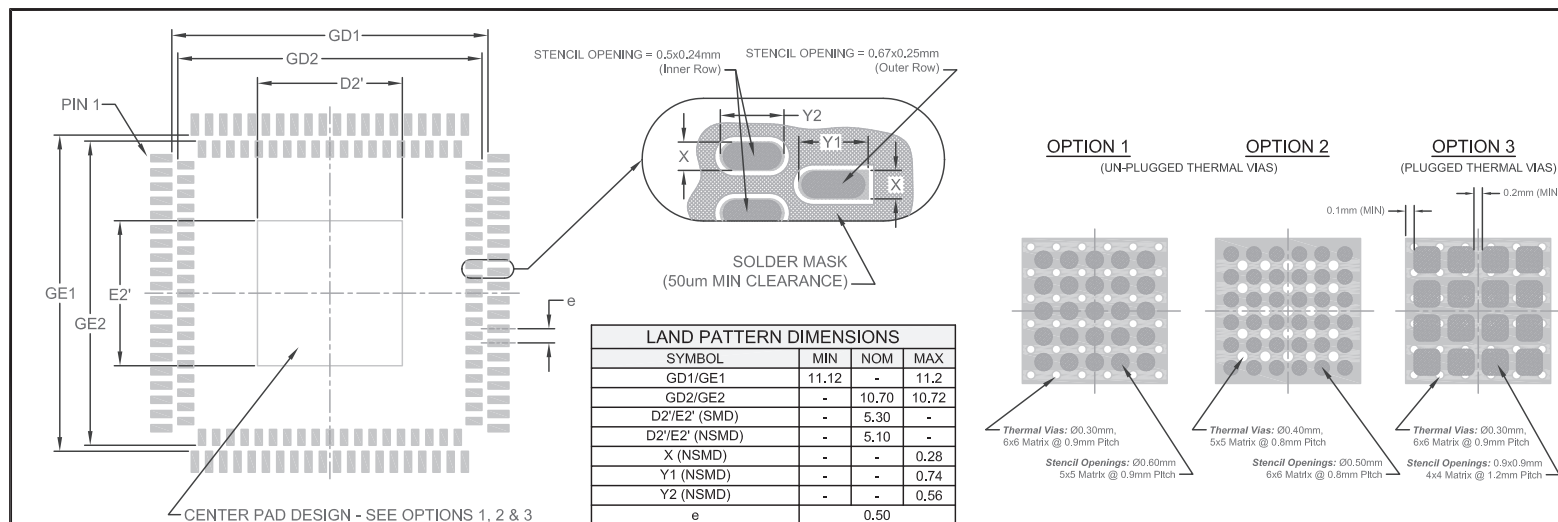

**RECOMMENDED PCB LAND PATTERN**

**SMT APPLICATION NOTES**

1. THE USER MAY MODIFY THE PCB LAND PATTERN DIMENSIONS BASED ON THEIR EXPERIENCE AND/OR PROCESS CAPABILITY.
2. THE LAND PATTERN CORRESPONDING TO THE PACKAGE EXPOSED PAD (IN THE CENTER) CAN BE LARGER, AND WITH DIFFERENT SHAPE THAN THE EXPOSED PAD ON THE PACKAGE, HOWEVER, THE SOLDERABLE AREA, AS DEFINED BY THE SOLDER MASK, SHOULD BE AS SHOWN FOR THE BEST THERMAL & ELECTRICAL PERFORMANCE:  
NSMD: 5.1x5.1mm  
SMD: 5.3x5.3mm
3. MAXIMUM THERMAL AND ELECTRICAL PERFORMANCE IS ACHIEVED WHEN AN ARRAY OF SOLID VIAS IS INCORPORATED IN THE CENTER LAND PATTERN. (See Options 1, 2 & 3)
4. THE VIAS SHOULD BE AT 0.8 TO 1.0MM PITCH WITH 0.30 TO 0.40MM DIAMETER, AND 1 OZ COPPER VIA BARREL PLATING.
5. NON SOLDER MASK DEFINED (NSMD) PAD DESIGN IS RECOMMENDED FOR PERIMETER LANDS.
6. A LASER-CUT STAINLESS STEEL STENCIL IS RECOMMENDED WITH ELECTRO POLISHED TRAPEZOIDAL WALLS, THE RECOMMENDED STENCIL THICKNESS IS 0.125 mm FOR PITCHES 0.4 and 0.5 mm.
7. RECOMMENDED STENCIL AREA & ASPECT RATIOS ARE 0.66 & 1.5 RESPECTIVELY.
8. RECOMMENDED STENCIL APERTURES ARE AS SHOWN.
9. IT IS RECOMMENDED TO USE "NO-CLEAN", TYPE 3 SOLDER PASTE.
10. THE REFLOW PROFILE DEPENDS ON THE EXACT SOLDER PASTE USED AND THE GIVEN BOARD DETAILS, SUCH AS GEOMETRY, COMPONENTS ETC.

UNLESS OTHERWISE SPECIFIED DIMENSIONS ARE IN MILLIMETERS AND TOLERANCES ARE:  DECIMAL                      ANGULAR XX    ±0.1                      ±1° X.XX   ±0.05 X.XXX ±0.025  INTERPRET DIM AND TOL PER ASME Y14.5M - 1994	THIRD ANGLE PROJECTION  	Note: For the most current package drawings, see the Microchip Packaging Specification at <a href="http://www.microchip.com/packaging">http://www.microchip.com/packaging</a>
MATERIAL -	DRAWN S.K.JLIEV    2/1/05	TITLE  <b>APPLICATION NOTES</b> 156DQFN-51, 12x12 MM BODY, 0.5 MM PITCH
FINISH -	CHECKED S.K.JLIEV    2/1/05	DWG NUMBER 156DQFN-51-12x12B
PRINT WITH "SCALE TO FIT" DO NOT SCALE DRAWING	APPROVED S.K.JLIEV    5/6/05	SCALE    1:1 STD COMPLIANCE    - SHEET    2 OF 2



**MICROCHIP**

---

---

## Legacy SMSC Packaging Outlines and Dimensions

---

---

NOTES:

---

---

**Legacy SMSC Packaging Outlines and Dimensions**

---

---

**DS Family**

SMSC Legacy

## Legacy SMSC Packaging Outlines and Dimensions

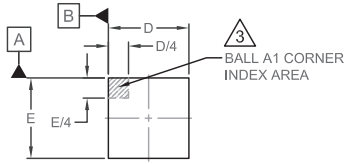

**TOP VIEW**

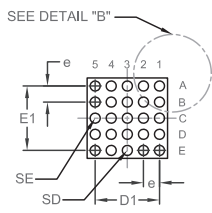

**BOTTOM VIEW**

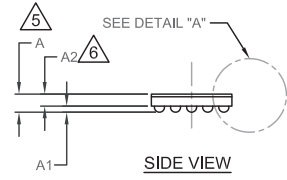

**SIDE VIEW**

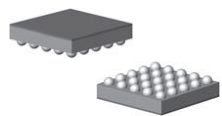

**3-D VIEWS**

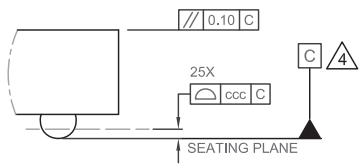

**DETAIL A**

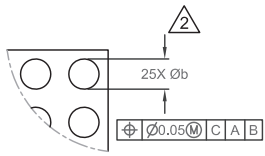

**DETAIL B**

**LAND PATTERN DIMENSIONS**

SYMBOL	MIN	NOM	MAX
D1'E1'	-	1.60	-
b'	0.20	0.23	-
e'	-	0.40	-

THE USER MAY MODIFY THE PCB LAND PATTERN DIMENSIONS, BASED ON THEIR EXPERIENCE AND/OR PROCESS CAPABILITY

**PCB LAND PATTERN**

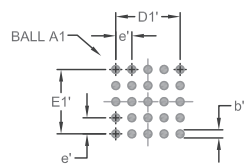

REVISION HISTORY			
REV	DESCRIPTION	DATE	REL. BY
A	INITIAL RELEASE	10/24/07	S.K.ILIEV
B	PCB LAND PATTERN UPDATED	4/20/09	S.K.ILIEV
C	D/E from 1.94 - 1.97 to 1.97±0.03mm	11/16/09	S.K.ILIEV
D	A from NOM & MAX to range MIN - MAX. ADDED SD and SE	MAR2010	S.K.ILIEV
E	UPDATED b' to be 0.20 MIN & 0.23 NOM	SEP 2010	SKI

COMMON DIMENSIONS					
SYMBOL	MIN	NOM	MAX	NOTE	REMARK
A	0.52	0.56	0.62	5	OVERALL PACKAGE HEIGHT
A1	0.16	0.20	0.24	-	STANDOFF
A2	-	-	0.38	6	PACKAGE THICKNESS
D/E	1.94	1.97	2.00	-	X/Y DIE SIZE
D1/E1	1.60 BSC		-	-	X/Y END BALLS DISTANCE
b	0.20	0.25	0.30	2	BALL DIAMETER
e	0.40 BSC		-	-	BALL PITCH
SD/SE	0.00		-	-	CENTER BALL POSITION (OUTER ROW)
ccc	0	-	0.05	4	COPLANARITY

**NOTES:**

- ALL DIMENSIONS ARE IN MILLIMETERS.
- DIMENSION "b" IS MEASURED AT THE MAXIMUM BALL DIAMETER, PARALLEL TO PRIMARY DATUM "C".
- THE BALL "A1" CORNER MUST BE IDENTIFIED IN THE INDICATED AREA OF THE TOP PACKAGE SURFACE.
- PRIMARY DATUM "C" AND SEATING PLANE ARE DEFINED BY THE SPHERICAL CROWNS OF THE CONTACT SOLDER BALLS.
- DIMENSION "A" DOES NOT INCLUDE ATTACHED EXTERNAL FEATURES, SUCH AS HEAT SINK OR CHIP CAPACITORS. DIMENSION "A(MAX)" IS GIVEN FOR THE EXTREMELY THIN VARIATION OF THE PACKAGE PROFILE HEIGHT.
- DIMENSION "A2" INCLUDES A DIE COATING THICKNESS.

UNLESS OTHERWISE SPECIFIED DIMENSIONS ARE IN MILLIMETERS AND TOLERANCES ARE: DECIMAL      ANGULAR XX ±0.1        ±1° XXX ±0.05 XXXX ±0.025 INTERPRET DIM AND TOL PER ASME Y14.5M - 1994	THIRD ANGLE PROJECTION 	Note: For the most current package drawings, see the Microchip Packaging Specification at <a href="http://www.microchip.com/packaging">http://www.microchip.com/packaging</a>
MATERIAL N/A	DRAWN - 7/14/07	TITLE <b>PACKAGE OUTLINE</b> 25 Ball DSe1, 0.40mm Pitch, e1=SAC Ball Material DSe1 = Die Size Package, or WL CSP
FINISH N/A	CHECKED S.K.ILIEV 10/23/07	DWG NUMBER 25DSe1-2x2B-0.4P REV E
PRINT WITH "SCALE TO FIT" DO NOT SCALE DRAWING	APPROVED S.K.ILIEV 10/24/07	SCALE 1:1 STD COMPLIANCE MO-211 SHEET 1 OF 1



## Legacy SMSC Packaging Outlines and Dimensions

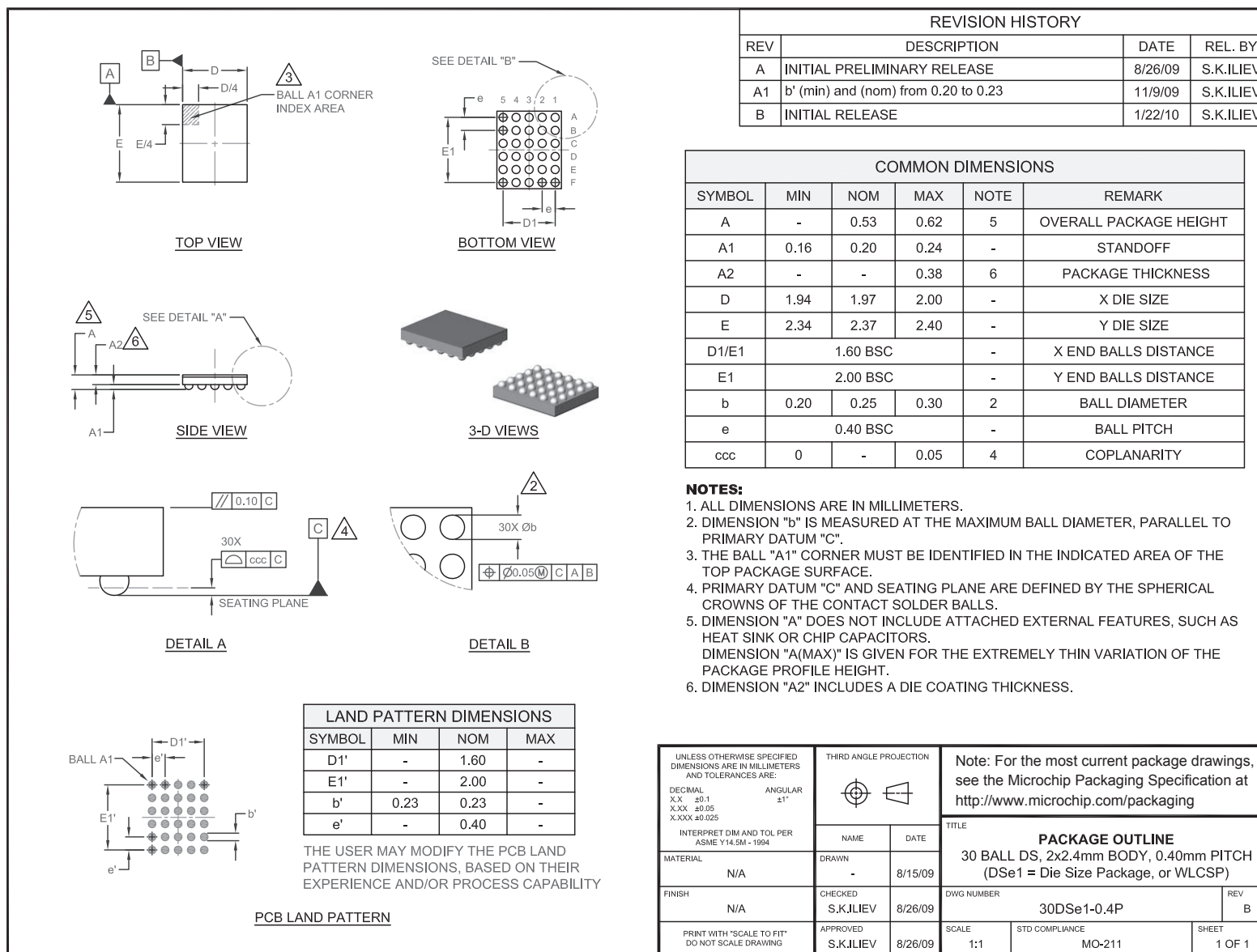



**MICROCHIP**

---

---

**Legacy SMSC Packaging Outlines and Dimensions**

---

---

**NOTES:**

---

---

## Legacy SMSC Packaging Outlines and Dimensions

---

---

### **LBGA**

SMSC Legacy

## Legacy SMSC Packaging Outlines and Dimensions

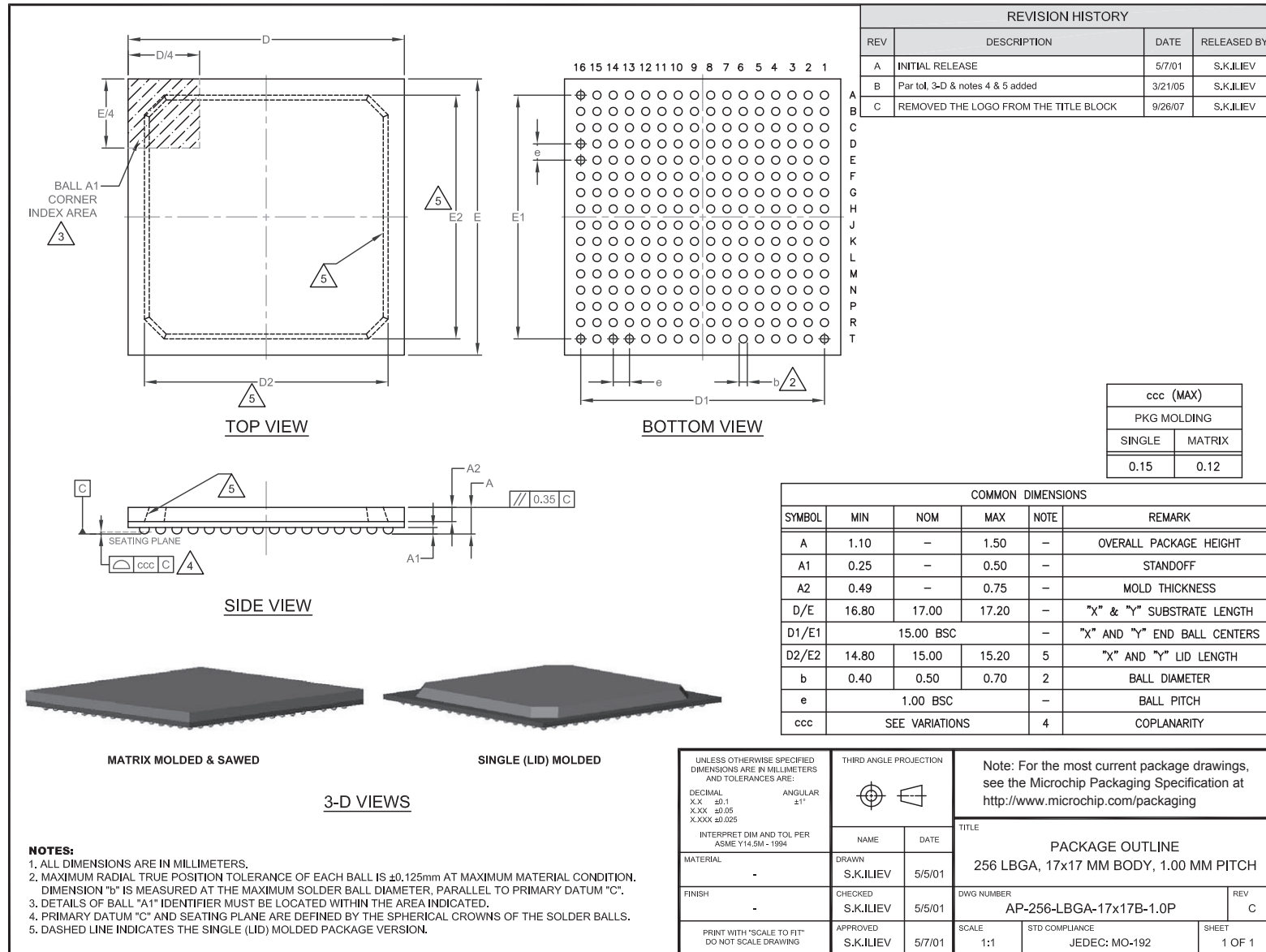

---

---

## Legacy SMSC Packaging Outlines and Dimensions

---

---

### **DSA**

SMSC Legacy

## Legacy SMSC Packaging Outlines and Dimensions

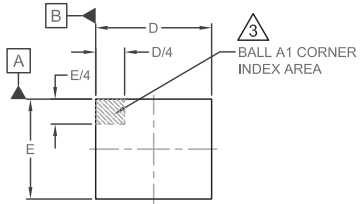

**TOP VIEW**

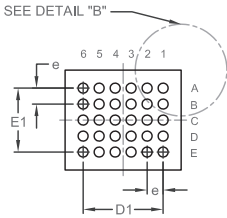

**BOTTOM VIEW**

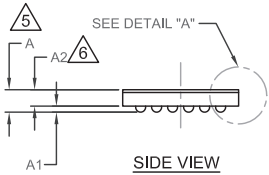

**SIDE VIEW**

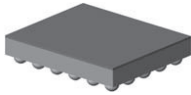

**3-D VIEW**

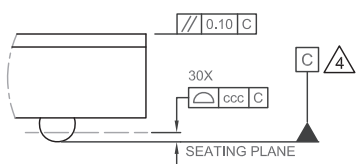

**DETAIL A**

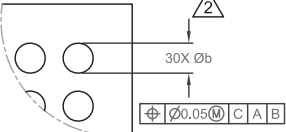

**DETAIL B**

**LAND PATTERN DIMENSIONS**

SYMBOL	MIN	NOM	MAX
D1'	-	2.00	-
E1'	-	1.60	-
b'	0.23	0.23	-
e'	-	0.40	-

THE USER MAY MODIFY THE PCB LAND PATTERN DIMENSIONS, BASED ON THEIR EXPERIENCE AND/OR PROCESS CAPABILITY

**PCB LAND PATTERN**

REVISION HISTORY			
REV	DESCRIPTION	DATE	REL. BY
A	INITIAL PRELIMINARY RELEASE	9/10/2012	S.K.ILIEV
A1	UPDATED A1 CORNER ON TOP VIEW TO MATCH THE ONE IN BOTTOM VIEW	3/19/2012	SKI
A2	ADDED 3-D VIEW	3/23/2012	SKI
A3	ROTATE PKG 90° CLOCKWISE	3/28/2012	SKI
B	INITIAL RELEASE	1/25/2013	SKI

  

COMMON DIMENSIONS					
SYMBOL	MIN	NOM	MAX	NOTE	REMARK
A	-	0.56	0.62	5	OVERALL PACKAGE HEIGHT
A1	0.16	0.20	0.24	-	STANDOFF
A2	-	-	0.38	6	PACKAGE THICKNESS
D	2.87	2.90	2.93	-	X DIE SIZE
E	2.47	2.50	2.53	-	Y DIE SIZE
D1	2.00 BSC		-	-	X END BALLS DISTANCE
E1	1.60 BSC		-	-	Y END BALLS DISTANCE
b	0.20	0.25	0.30	2	BALL DIAMETER
e	0.40 BSC		-	-	BALL PITCH
ccc	0	-	0.05	4	COPLANARITY

**NOTES:**

- ALL DIMENSIONS ARE IN MILLIMETERS.
- DIMENSION "b" IS MEASURED AT THE MAXIMUM BALL DIAMETER, PARALLEL TO PRIMARY DATUM "C".
- THE BALL "A1" CORNER MUST BE IDENTIFIED IN THE INDICATED AREA OF THE TOP PACKAGE SURFACE.
- PRIMARY DATUM "C" AND SEATING PLANE ARE DEFINED BY THE SPHERICAL CROWNS OF THE CONTACT SOLDER BALLS.
- DIMENSION "A" DOES NOT INCLUDE ATTACHED EXTERNAL FEATURES, SUCH AS HEAT SINK OR CHIP CAPACITORS. DIMENSION "A(MAX)" IS GIVEN FOR THE EXTREMELY THIN VARIATION OF THE PACKAGE PROFILE HEIGHT.
- DIMENSION "A2" INCLUDES A DIE COATING THICKNESS.

UNLESS OTHERWISE SPECIFIED DIMENSIONS ARE IN MILLIMETERS AND TOLERANCES ARE: DECIMAL X.XX ±0.1 X.XXX ±0.05 X.XXX ±0.025 INTERPRET DIM AND TOL PER ASME Y14.5M - 1994	THIRD ANGLE PROJECTION 	<p>Note: For the most current package drawings, see the Microchip Packaging Specification at <a href="http://www.microchip.com/packaging">http://www.microchip.com/packaging</a></p>																	
MATERIAL: N/A FINISH: N/A PRINT WITH "SCALE TO FIT" DO NOT SCALE DRAWING		<table border="1" style="width: 100%; border-collapse: collapse;"> <tr> <td>NAME</td> <td>DATE</td> <td>TITLE</td> </tr> <tr> <td>DRAWN: -</td> <td>2/9/12</td> <td rowspan="2" style="text-align: center;"><b>PACKAGE OUTLINE</b> 30 BALL DSA, 2.5x2.9mm BODY, 0.40mm PITCH (DSA = Die Size Package, or WLCSF)</td> </tr> <tr> <td>CHECKED: S.K.ILIEV</td> <td>2/9/12</td> </tr> <tr> <td>APPROVED: S.K.ILIEV</td> <td>2/10/12</td> <td>DWG NUMBER: 30DSA-0.4P</td> </tr> <tr> <td colspan="2">SCALE: 1:1</td> <td>REV: B</td> </tr> <tr> <td colspan="2">STD COMPLIANCE: MO-211</td> <td>SHEET: 1 OF 1</td> </tr> </table>	NAME	DATE	TITLE	DRAWN: -	2/9/12	<b>PACKAGE OUTLINE</b> 30 BALL DSA, 2.5x2.9mm BODY, 0.40mm PITCH (DSA = Die Size Package, or WLCSF)	CHECKED: S.K.ILIEV	2/9/12	APPROVED: S.K.ILIEV	2/10/12	DWG NUMBER: 30DSA-0.4P	SCALE: 1:1		REV: B	STD COMPLIANCE: MO-211		SHEET: 1 OF 1
NAME	DATE	TITLE																	
DRAWN: -	2/9/12	<b>PACKAGE OUTLINE</b> 30 BALL DSA, 2.5x2.9mm BODY, 0.40mm PITCH (DSA = Die Size Package, or WLCSF)																	
CHECKED: S.K.ILIEV	2/9/12																		
APPROVED: S.K.ILIEV	2/10/12	DWG NUMBER: 30DSA-0.4P																	
SCALE: 1:1		REV: B																	
STD COMPLIANCE: MO-211		SHEET: 1 OF 1																	

---

---

## Legacy SMSC Packaging Outlines and Dimensions

---

---

### **LFBGA**

SMSC Legacy

## Legacy SMSC Packaging Outlines and Dimensions

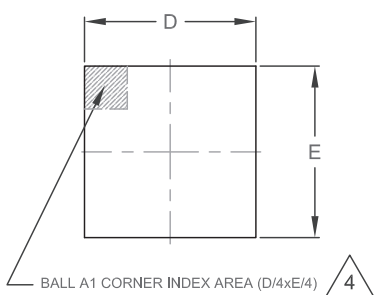

TOP VIEW

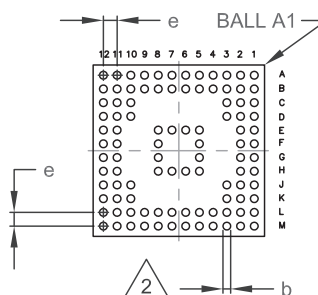

BOTTOM VIEW

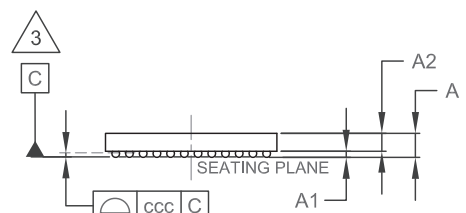

SIDE VIEW

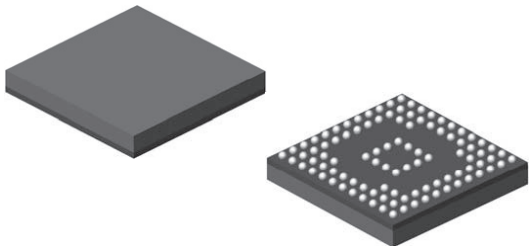

3-D VIEWS

REVISION HISTORY			
REVISION	DESCRIPTION	DATE	RELEASED BY
A	INITIAL PRELIMINARY RELEASE	8/22/07	S.K.ILIEV
B	INITIAL PRODUCTION RELEASE	3/20/08	S.K.ILIEV
C	ADDED PAGE 2 of 2, UPDATED APP NOTES.	2/7/09	S.K.ILIEV

COMMON DIMENSIONS					
SYMBOL	MIN	NOM	MAX	NOTE	REMARK
A	-	1.60	1.70	-	OVERALL PACKAGE HEIGHT
A1	0.25	0.34	-	-	STANDOFF
A2	1.16	1.26	1.36	-	PACKAGE BODY THICKNESS
D/E	9.90	10.00	10.10	-	OVERALL PACKAGE SIZE
b	0.40	0.45	0.50	2	BALL DIAMETER
e	0.80 BSC			-	BALL PITCH
ccc	-	-	0.20	3	COPLANARITY

**NOTES:**

- ALL DIMENSIONS ARE IN MILLIMETERS.
- MAXIMUM RADIAL TRUE POSITION TOLERANCE OF EACH BALL IS  $\pm 0.075\text{mm}$  AT MAXIMUM MATERIAL CONDITION. DIMENSION "b" IS MEASURED AT THE MAXIMUM BALL DIAMETER, PARALLEL TO PRIMARY DATUM "C".
- PRIMARY DATUM C (SEATING PLANE) IS DEFINED BY THE SPHERICAL CROWNS OF THE CONTACT BALLS.
- A1 CORNER MUST BE IDENTIFIED ON THE TOP SURFACE OF THE PACKAGE BY USING A CORNER CHAMFER, INK OR METALIZED MARKINGS, IDENTATION OR OTHER FEATURE OF PACKAGE BODY. EXACT SHAPE OF EACH CORNER IS OPTIONAL, BUT PIN 1 CORNER MUST BE INIQUE.

<small>UNLESS OTHERWISE SPECIFIED DIMENSIONS ARE IN MILLIMETERS AND TOLERANCES ARE:</small> DECIMAL            ANGULAR X.X $\pm 0.1$ $\pm 1^\circ$ X.XX $\pm 0.05$ X.XXX $\pm 0.025$ <small>INTERPRET DIM AND TOL PER ASME Y14.5M - 1994</small>	<small>THIRD ANGLE PROJECTION</small> 	Note: For the most current package drawings, see the Microchip Packaging Specification at <a href="http://www.microchip.com/packaging">http://www.microchip.com/packaging</a>																														
<table border="1" style="width: 100%; border-collapse: collapse;"> <tr> <td style="width: 30%;">MATERIAL</td> <td style="width: 30%;">DRAWN</td> <td style="width: 40%;">DATE</td> </tr> <tr> <td style="text-align: center;">-</td> <td style="text-align: center;">-</td> <td style="text-align: center;">8/20/07</td> </tr> </table>	MATERIAL	DRAWN	DATE	-	-	8/20/07	<table border="1" style="width: 100%; border-collapse: collapse;"> <tr> <td style="width: 30%;">FINISH</td> <td style="width: 30%;">CHECKED</td> <td style="width: 40%;">DATE</td> </tr> <tr> <td style="text-align: center;">-</td> <td style="text-align: center;">-</td> <td style="text-align: center;">8/20/07</td> </tr> </table>	FINISH	CHECKED	DATE	-	-	8/20/07	<table border="1" style="width: 100%; border-collapse: collapse;"> <tr> <td colspan="3" style="text-align: center;">TITLE</td> </tr> <tr> <td colspan="3" style="text-align: center;">PACKAGE DATA</td> </tr> <tr> <td colspan="3" style="text-align: center;">100 BALL LFBGA, 10x10mm BODY, 0.8mm PITCH</td> </tr> <tr> <td colspan="3" style="text-align: center;">Package Outline Drawing (POD)</td> </tr> <tr> <td colspan="2">DWG NUMBER</td> <td>REV</td> </tr> <tr> <td colspan="2" style="text-align: center;">100LFBGA-10x10B-0.8P</td> <td style="text-align: center;">C</td> </tr> </table>	TITLE			PACKAGE DATA			100 BALL LFBGA, 10x10mm BODY, 0.8mm PITCH			Package Outline Drawing (POD)			DWG NUMBER		REV	100LFBGA-10x10B-0.8P		C
MATERIAL	DRAWN	DATE																														
-	-	8/20/07																														
FINISH	CHECKED	DATE																														
-	-	8/20/07																														
TITLE																																
PACKAGE DATA																																
100 BALL LFBGA, 10x10mm BODY, 0.8mm PITCH																																
Package Outline Drawing (POD)																																
DWG NUMBER		REV																														
100LFBGA-10x10B-0.8P		C																														
<table border="1" style="width: 100%; border-collapse: collapse;"> <tr> <td style="width: 30%;">PRINT WITH "SCALE TO FIT" DO NOT SCALE DRAWING</td> <td style="width: 30%;">APPROVED</td> <td style="width: 40%;">DATE</td> </tr> <tr> <td></td> <td style="text-align: center;">S.K.ILIEV</td> <td style="text-align: center;">8/21/07</td> </tr> </table>	PRINT WITH "SCALE TO FIT" DO NOT SCALE DRAWING	APPROVED	DATE		S.K.ILIEV	8/21/07	<table border="1" style="width: 100%; border-collapse: collapse;"> <tr> <td style="width: 20%;">SCALE</td> <td style="width: 40%;">STD COMPLIANCE</td> <td style="width: 40%;">SHEET</td> </tr> <tr> <td style="text-align: center;">1:1</td> <td style="text-align: center;">JEDEC: MO-275</td> <td style="text-align: center;">1 OF 2</td> </tr> </table>	SCALE	STD COMPLIANCE	SHEET	1:1	JEDEC: MO-275	1 OF 2																			
PRINT WITH "SCALE TO FIT" DO NOT SCALE DRAWING	APPROVED	DATE																														
	S.K.ILIEV	8/21/07																														
SCALE	STD COMPLIANCE	SHEET																														
1:1	JEDEC: MO-275	1 OF 2																														



## Legacy SMSC Packaging Outlines and Dimensions

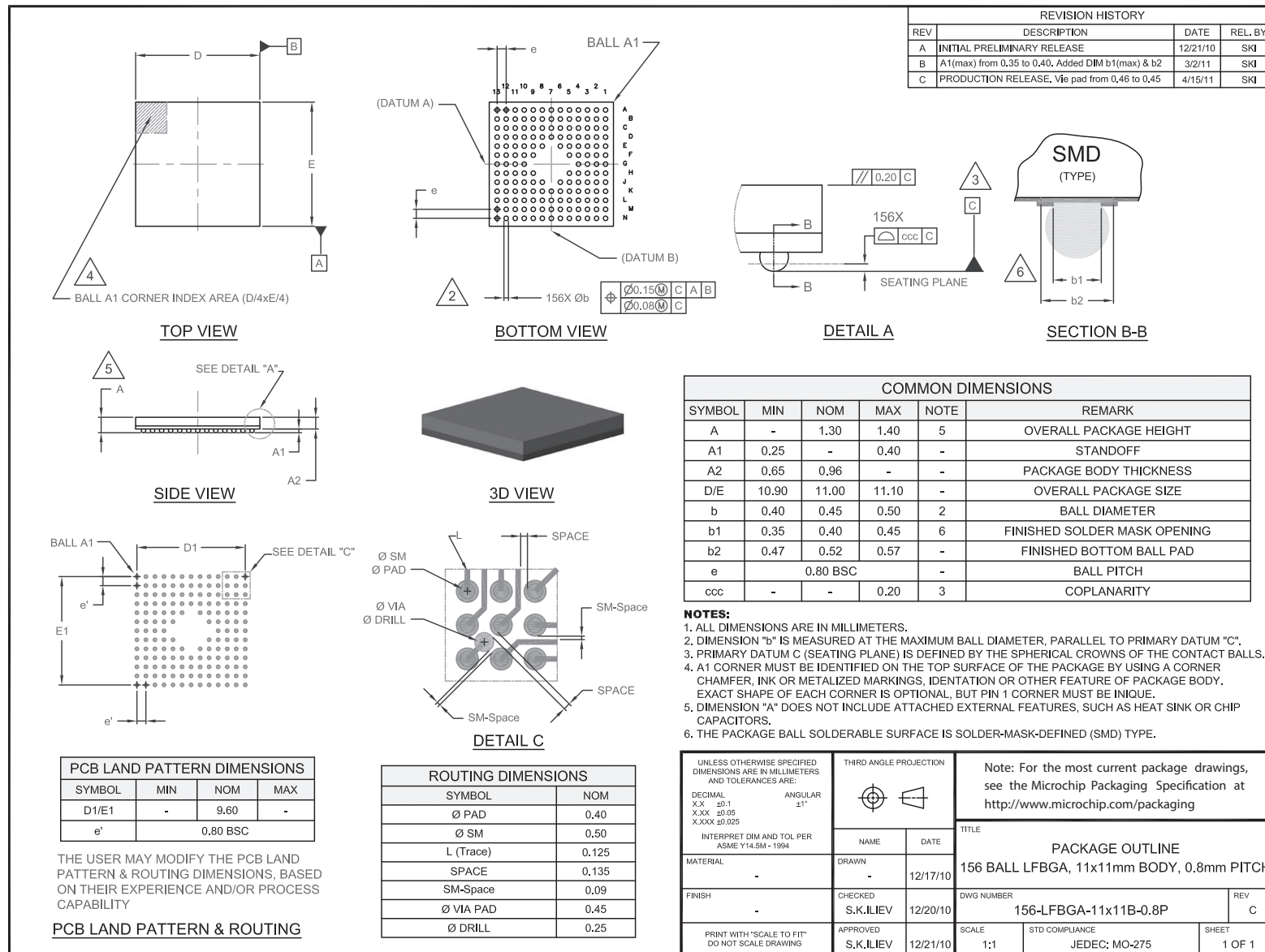

## Legacy SMSC Packaging Outlines and Dimensions

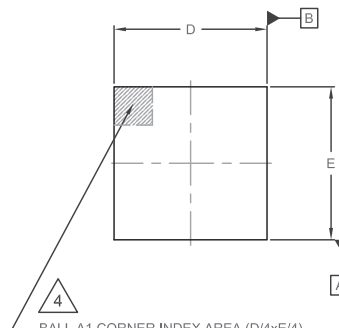

**TOP VIEW**

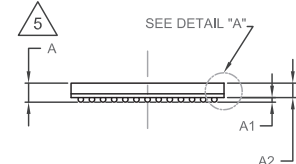

**SIDE VIEW**

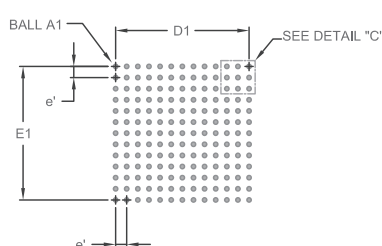

**PCB LAND PATTERN DIMENSIONS**

SYMBOL	MIN	NOM	MAX
D1/E1	-	9.60	-
e'	0.80 BSC		

THE USER MAY MODIFY THE PCB LAND PATTERN & ROUTING DIMENSIONS, BASED ON THEIR EXPERIENCE AND/OR PROCESS CAPABILITY

**PCB LAND PATTERN & ROUTING**

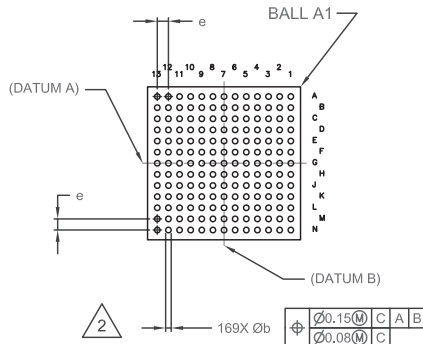

**BOTTOM VIEW**

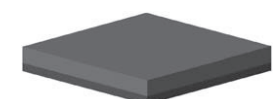

**3D VIEW**

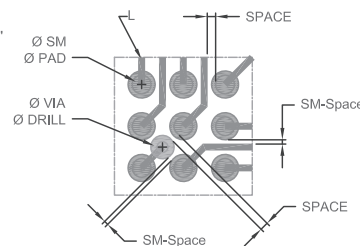

**DETAIL C**

**ROUTING DIMENSIONS**

SYMBOL	NOM
Ø PAD	0.40
Ø SM	0.50
L (Trace)	0.125
SPACE (Min)	0.135
SM-Space (Min)	0.09
Ø VIA PAD	0.45
Ø DRILL	0.25

REVISION HISTORY			
REV	DESCRIPTION	DATE	REL. BY
A	INITIAL PRELIMINARY RELEASE	11/7/11	SKJ
B	INITIAL RELEASE	2/15/12	SKJ

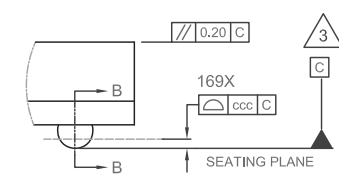

**DETAIL A**

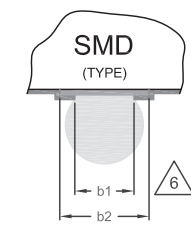

**SECTION B-B**

COMMON DIMENSIONS					
SYMBOL	MIN	NOM	MAX	NOTE	REMARK
A	-	1.30	1.40	5	OVERALL PACKAGE HEIGHT
A1	0.25	-	0.40	-	STANDOFF
A2	0.65	0.96	-	-	PACKAGE BODY THICKNESS
D/E	10.90	11.00	11.10	-	OVERALL PACKAGE SIZE
b	0.40	0.45	0.50	2	BALL DIAMETER
b1	0.35	0.40	0.45	6	FINISHED SOLDER MASK OPENING
b2	0.47	0.52	0.57	-	FINISHED BOTTOM BALL PAD
e	0.80 BSC			-	BALL PITCH
ccc	-	-	0.20	3	COPLANARITY

**NOTES:**

- ALL DIMENSIONS ARE IN MILLIMETERS.
- DIMENSION "b" IS MEASURED AT THE MAXIMUM BALL DIAMETER, PARALLEL TO PRIMARY DATUM "C".
- PRIMARY DATUM C (SEATING PLANE) IS DEFINED BY THE SPHERICAL CROWNS OF THE CONTACT BALLS.
- A1 CORNER MUST BE IDENTIFIED ON THE TOP SURFACE OF THE PACKAGE BY USING A CORNER CHAMFER, INK OR METALIZED MARKINGS, IDENTATION OR OTHER FEATURE OF PACKAGE BODY. EXACT SHAPE OF EACH CORNER IS OPTIONAL, BUT PIN 1 CORNER MUST BE INKUE.
- DIMENSION "A" DOES NOT INCLUDE ATTACHED EXTERNAL FEATURES, SUCH AS HEAT SINK OR CHIP CAPACITORS.
- THE PACKAGE BALL SOLDERABLE SURFACE IS SOLDER-MASK-DEFINED (SMD) TYPE.

UNLESS OTHERWISE SPECIFIED DIMENSIONS ARE IN MILLIMETERS AND TOLERANCES ARE:		THIRD ANGLE PROJECTION		Note: For the most current package drawings, see the Microchip Packaging Specification at <a href="http://www.microchip.com/packaging">http://www.microchip.com/packaging</a>
DECIMAL	ANGULAR	NAME	DATE	
X.X ±0.1	±1°			TITLE <b>PACKAGE OUTLINE</b>
X.XX ±0.05				
X.XXX ±0.025				169 BALL LFBGA, 11x11mm BODY, 0.8mm PITCH
INTERPRET DIM AND TOL PER ASME Y14.5M - 1994				
MATERIAL		DRAWN	11/4/11	DWG NUMBER 169-LFBGA-11x11B-0.8P
FINISH		CHECKED	11/4/11	REV B
		APPROVED	11/7/11	SCALE 1:1
PRINT WITH "SCALE TO FIT" DO NOT SCALE DRAWING				STD COMPLIANCE JEDEC: MO-275
				SHEET 1 OF 1

## Legacy SMSC Packaging Outlines and Dimensions

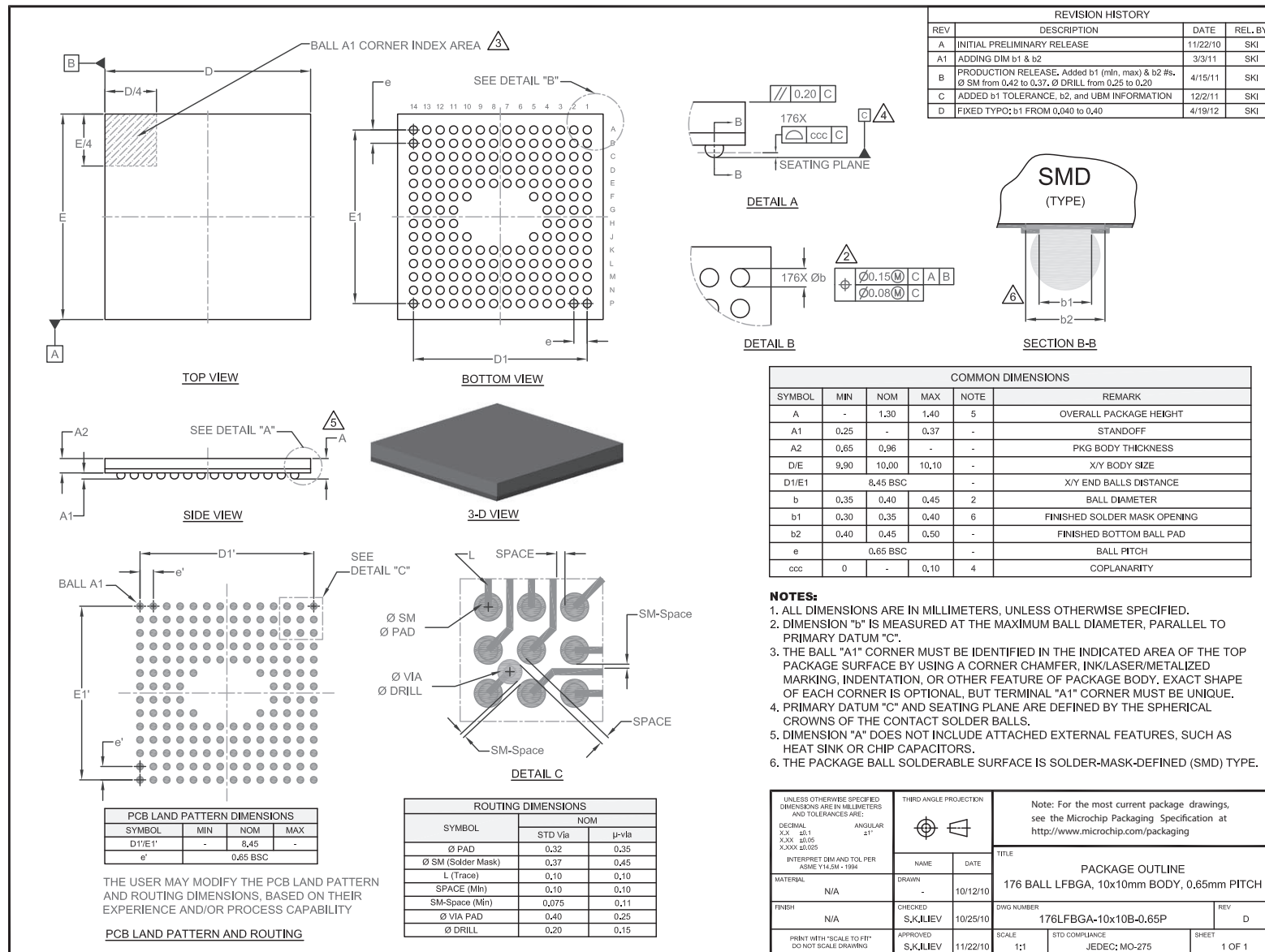

## Legacy SMSC Packaging Outlines and Dimensions

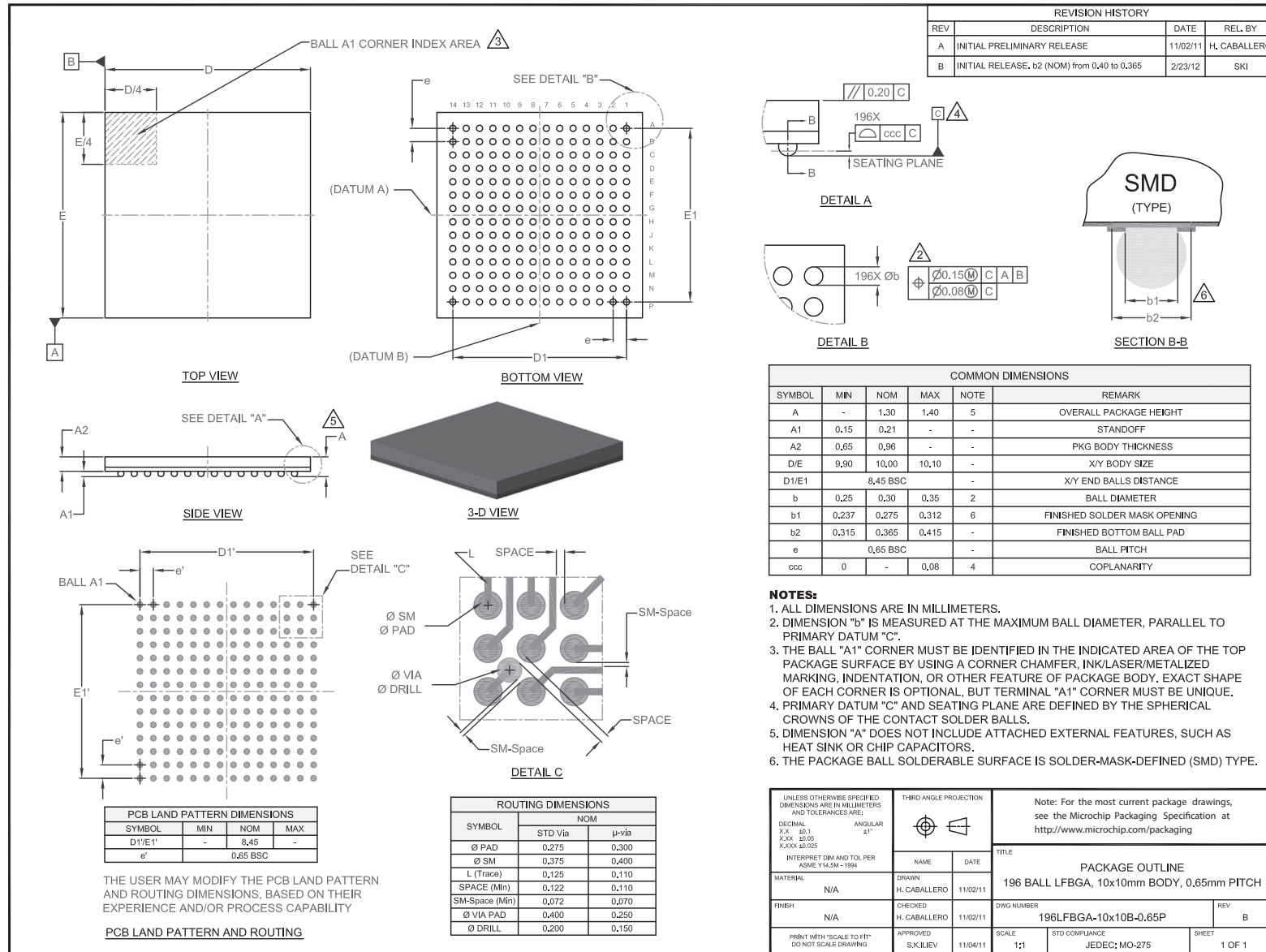

## Legacy SMSC Packaging Outlines and Dimensions

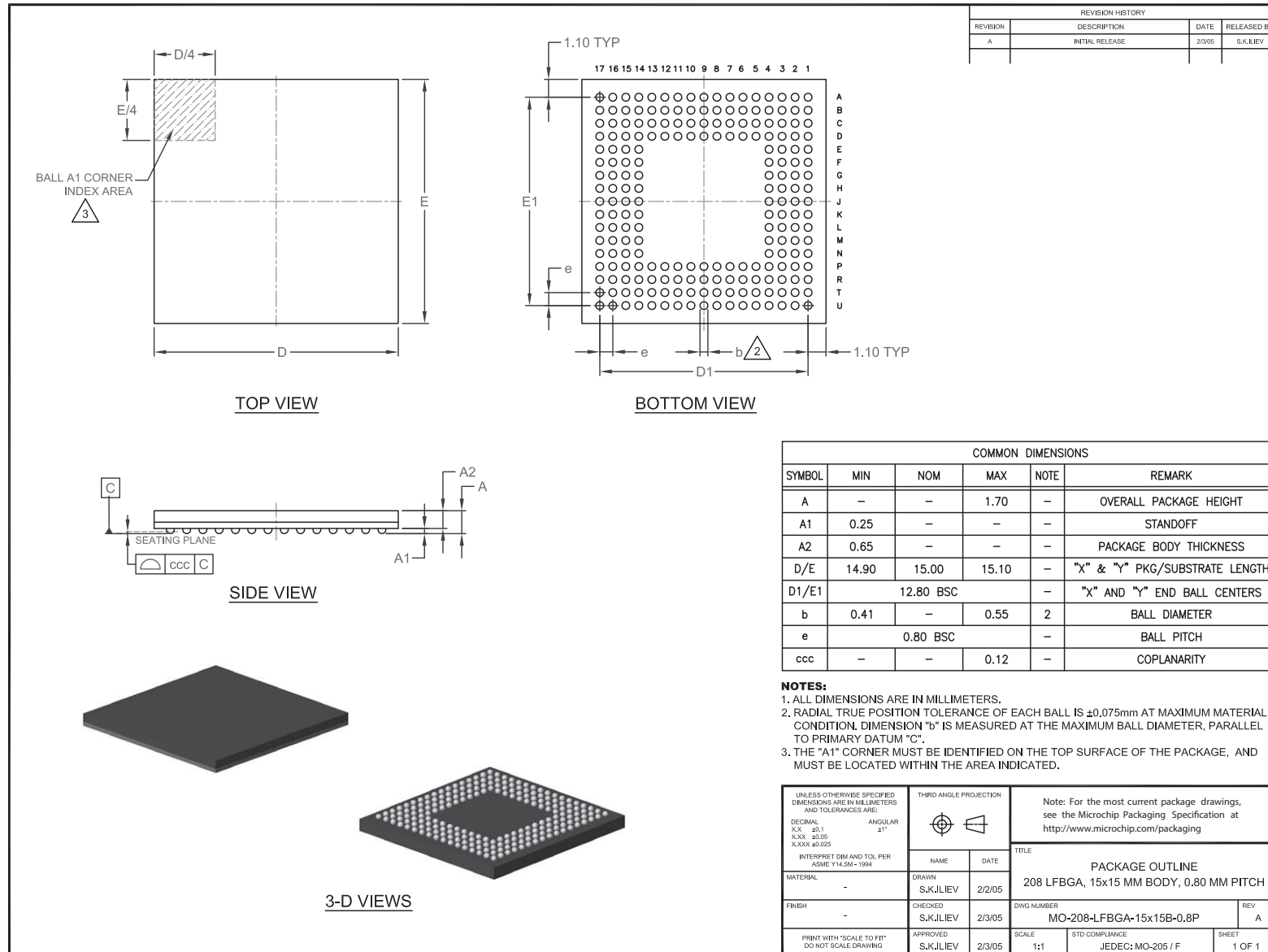

## Legacy SMSC Packaging Outlines and Dimensions

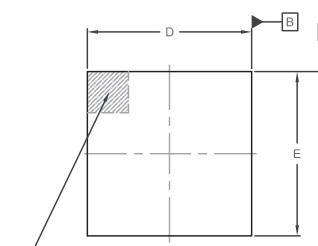

**TOP VIEW**

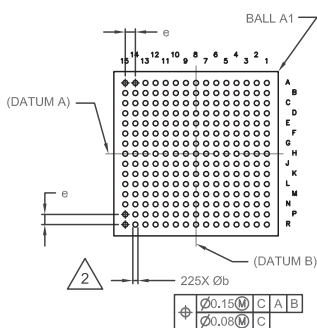

**BOTTOM VIEW**

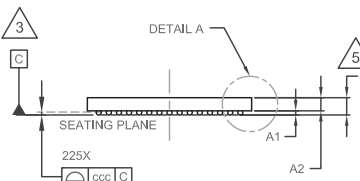

**SIDE VIEW**

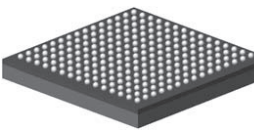

**3-D VIEW**

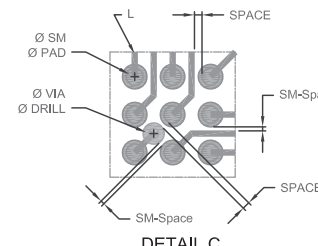

**DETAIL C**

REVISION HISTORY			
REV	DESCRIPTION	DATE	REL. BY
B	INITIAL PRODUCTION RELEASE, ADDED DIM "b2" & PCB ROUTING	2/15/2011	S,K,ILIEV

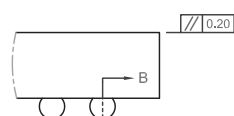
**DETAIL A**

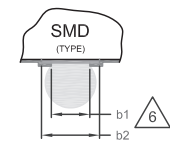

**SECTION B-B**

COMMON DIMENSIONS					
SYMBOL	MIN	NOM	MAX	NOTE	REMARK
A	-	1.30	1.40	5	OVERALL PACKAGE HEIGHT
A1	0.25	-	0.40	-	STANDOFF
A2	0.65	0.96	-	-	PACKAGE BODY THICKNESS
D/E	12.90	13.00	13.10	-	OVERALL PACKAGE SIZE
b	0.40	0.45	0.50	2	BALL DIAMETER
b1	0.35	0.40	0.45	6	FINISHED SOLDER MASK OPENING
b2	0.45	0.50	0.55	-	FINISHED BALL PAD DIAMETER
e	-	0.80 BSC	-	-	BALL PITCH
ccc	-	-	0.20	3	COPLANARITY

**NOTES:**

- ALL DIMENSIONS ARE IN MILLIMETERS.
- DIMENSION "b" IS MEASURED AT THE MAXIMUM BALL DIAMETER, PARALLEL TO PRIMARY DATUM "C".
- PRIMARY DATUM C (SEATING PLANE) IS DEFINED BY THE SPHERICAL CROWNS OF THE CONTACT BALLS.
- THE BALL "A1" CORNER MUST BE IDENTIFIED ON THE TOP SURFACE OF THE PACKAGE BY USING A CORNER CHAMFER, INK OR METALIZED MARKINGS, INDENTATION OR OTHER FEATURE OF PACKAGE BODY; EXACT SHAPE OF EACH CORNER IS OPTIONAL, BUT PIN 1 CORNER MUST BE UNIQUE.
- DIMENSION "A" DOES NOT INCLUDE ATTACHED EXTERNAL FEATURES, SUCH AS HEAT SINK OR CHIP CAPACITORS.
- THE PACKAGE BALL SOLDERABLE SURFACE IS SOLDER-MASK-DEFINED (SMD) TYPE.

PCB LAND PATTERN DIMENSIONS			
SYMBOL	MIN	NOM	MAX
D1/E1	-	11.20	-
e'	-	0.80 BSC	-



THE USER MAY MODIFY THE PCB LAND PATTERN & ROUTING DIMENSIONS, BASED ON THEIR EXPERIENCE AND/OR PROCESS CAPABILITY

ROUTING DIMENSIONS	
SYMBOL	NOM
Ø PAD	0.40
Ø SM	0.50
L (Trace)	0.125
SPACE (Min)	0.135
SM-Space (Min)	0.09
Ø VIA PAD	0.45
Ø DRILL	0.25

**PCB LAND PATTERN**

THIRD ANGLE PROJECTION	
	

Note: For the most current package drawings, see the Microchip Packaging Specification at <http://www.microchip.com/packaging>

TITLE	
<b>PACKAGE OUTLINE</b>	
225 BALL LFBGA, 13x13mm BODY, 0.8mm PITCH	

NAME	DATE
DRAWN	8/5/09
CHECKED	8/5/09
APPROVED	8/6/09

DWG NUMBER		REV
225-LFBGA-13x13B-0.8P		B

SCALE	STD COMPLIANCE	SHEET
1:1	JEDEC; MO-275	1 OF 1

## Legacy SMSC Packaging Outlines and Dimensions

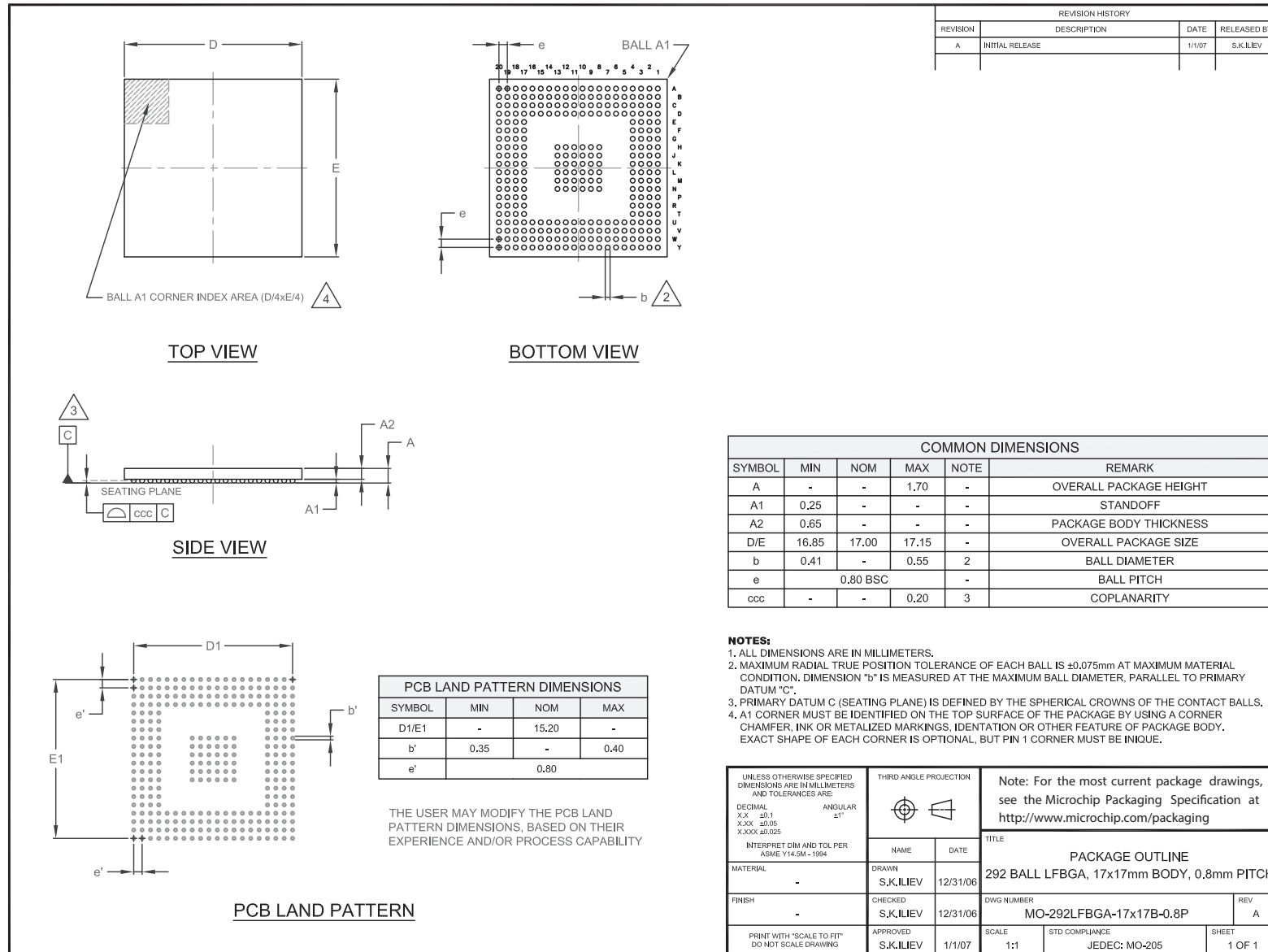



## Legacy SMSC Packaging Outlines and Dimensions

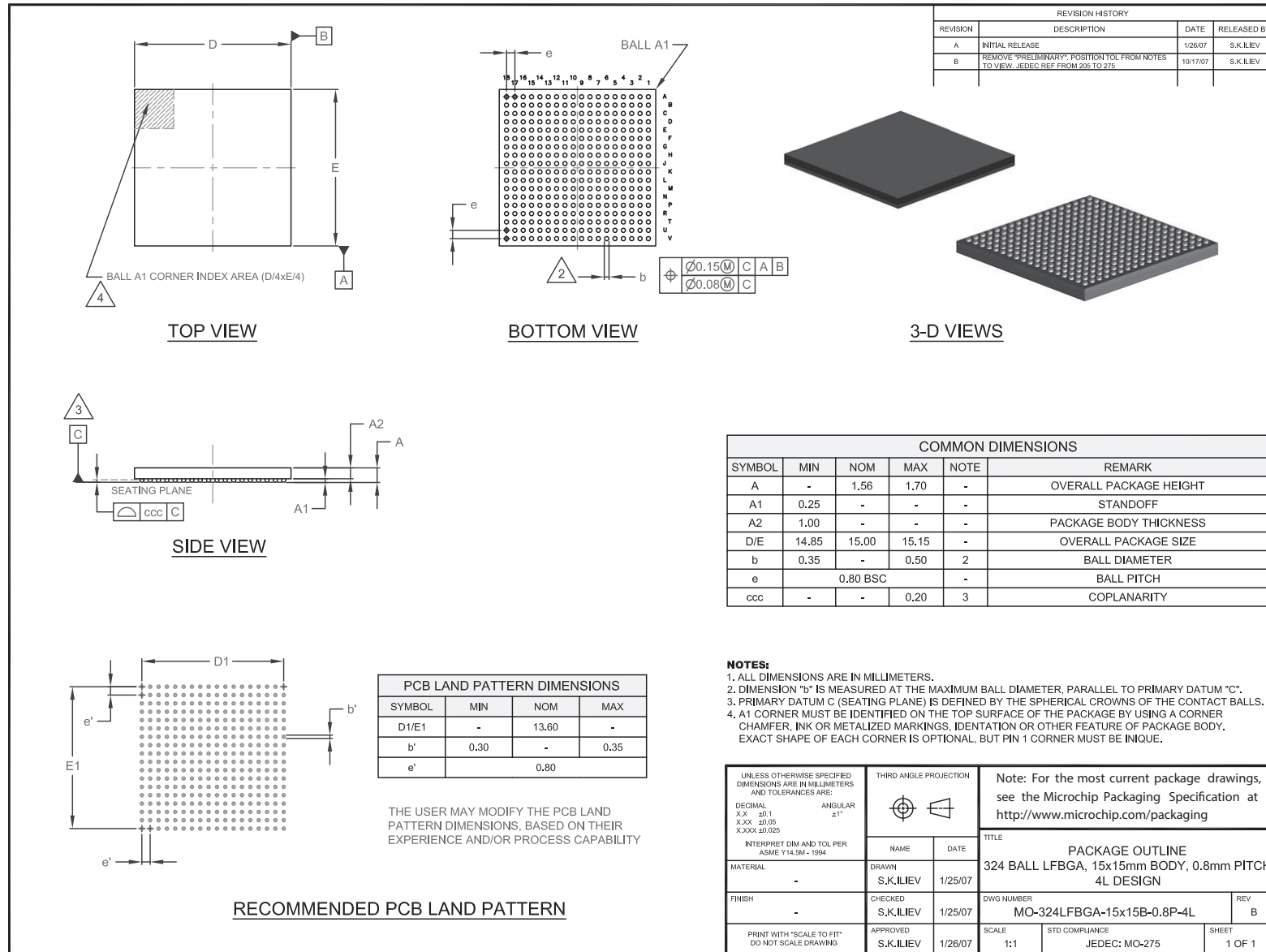



---

---

## Legacy SMSC Packaging Outlines and Dimensions

---

---

### **LGA**

SMSC Legacy

## Legacy SMSC Packaging Outlines and Dimensions

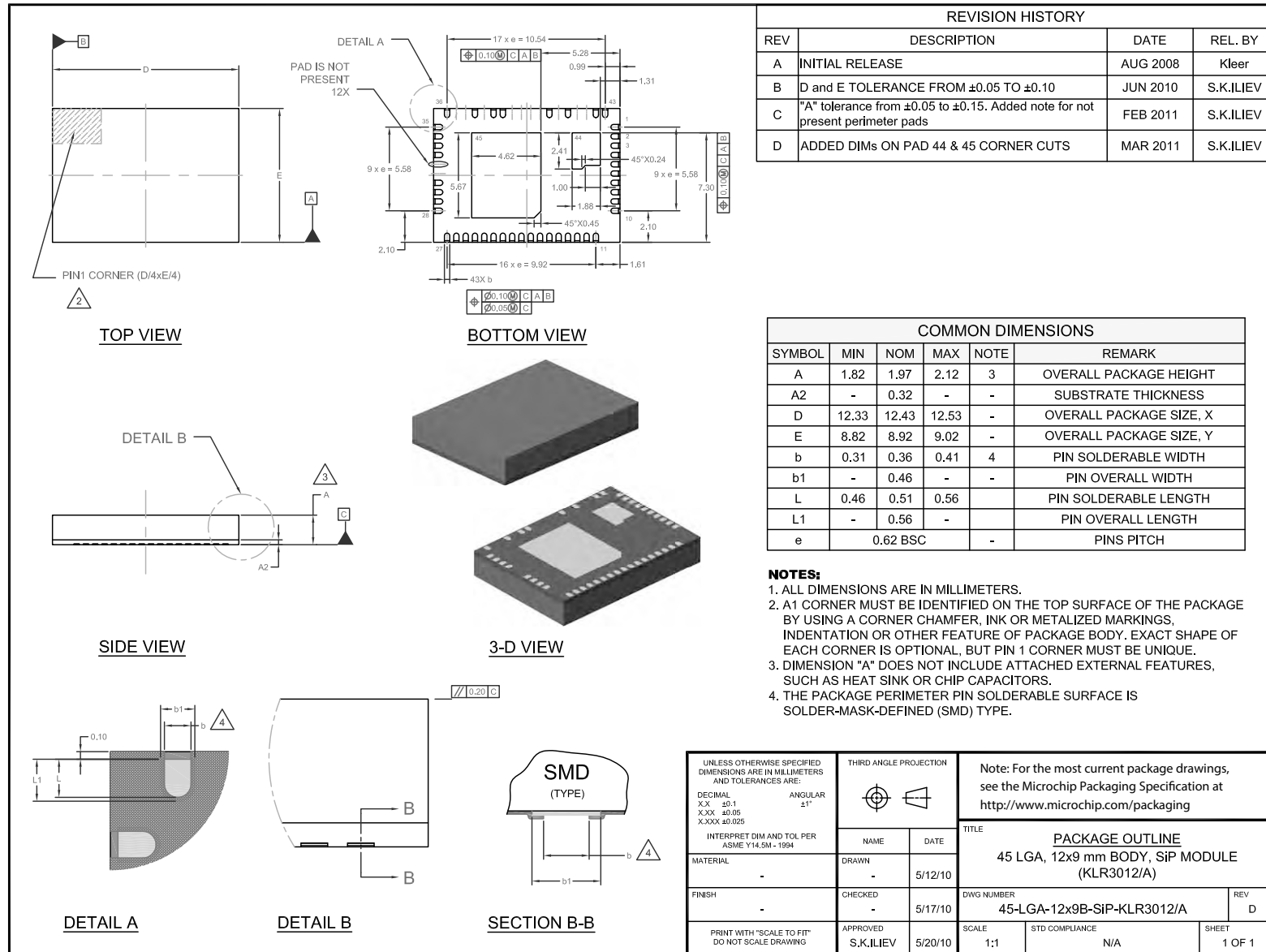

## Legacy SMSC Packaging Outlines and Dimensions

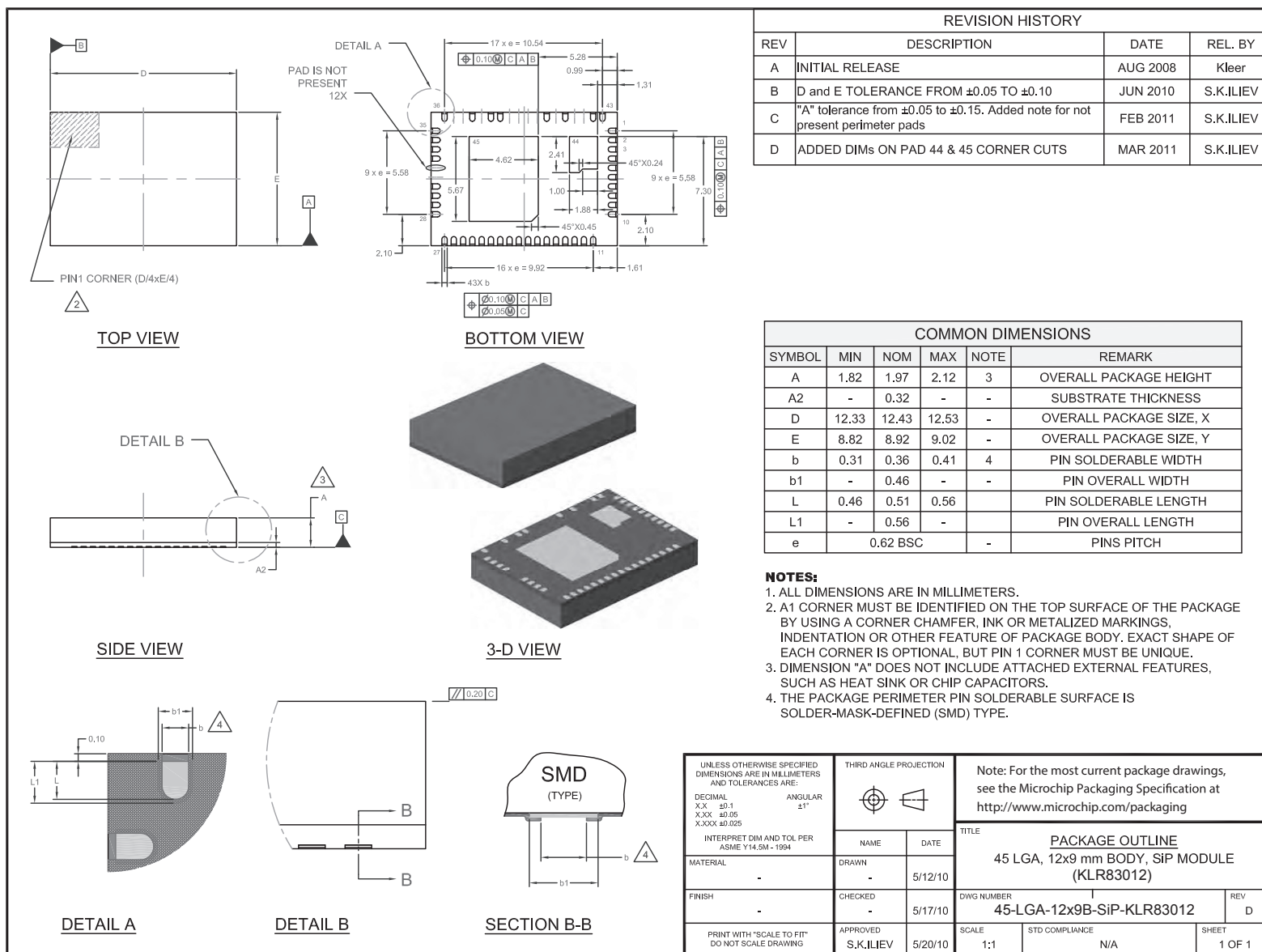



**MICROCHIP**

---

---

**Legacy SMSC Packaging Outlines and Dimensions**

---

---

**NOTES:**

---

---

## Legacy SMSC Packaging Outlines and Dimensions

---

---

### **LQFP**

SMSC Legacy

## Legacy SMSC Packaging Outlines and Dimensions

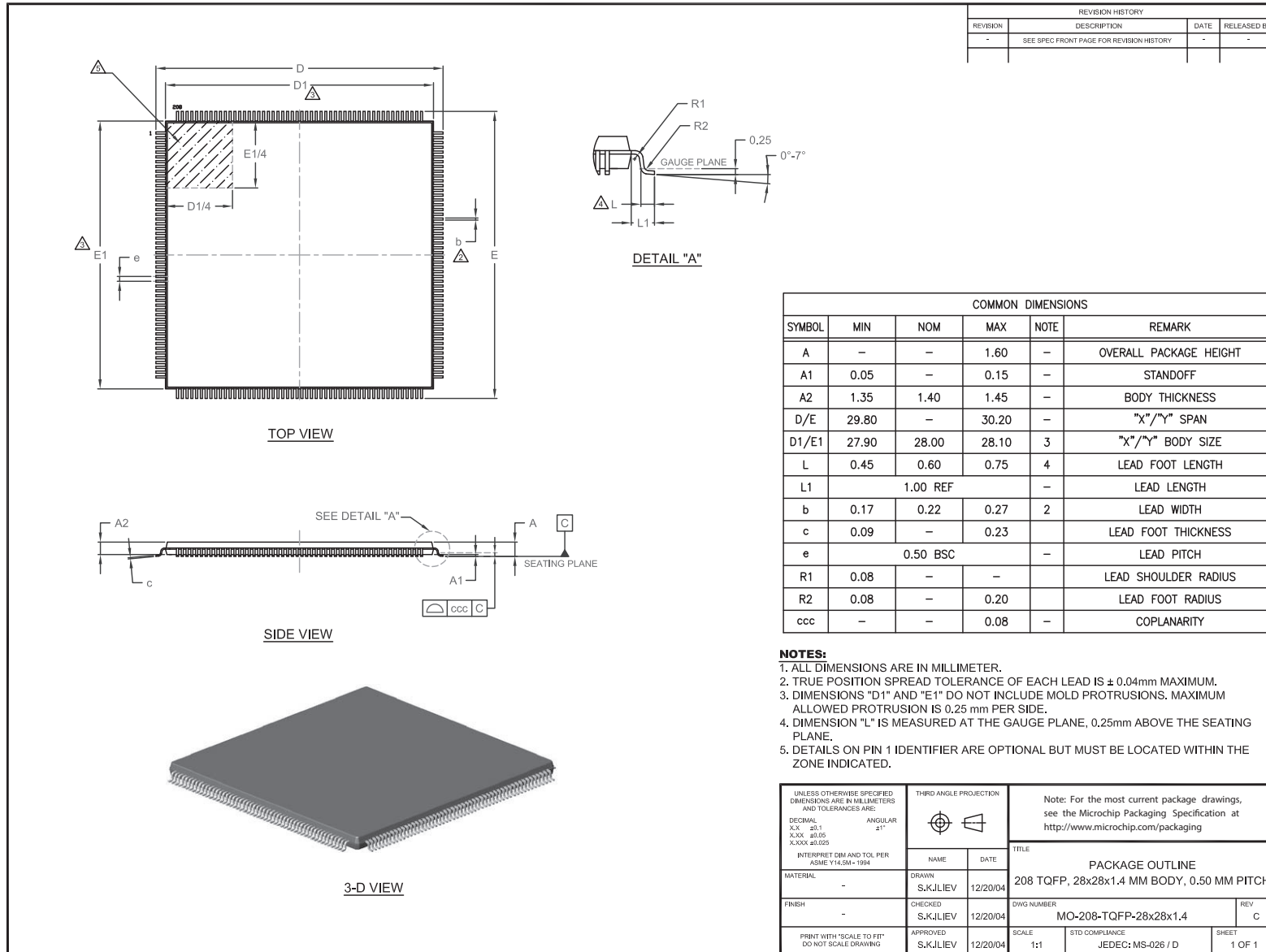

## Legacy SMSC Packaging Outlines and Dimensions

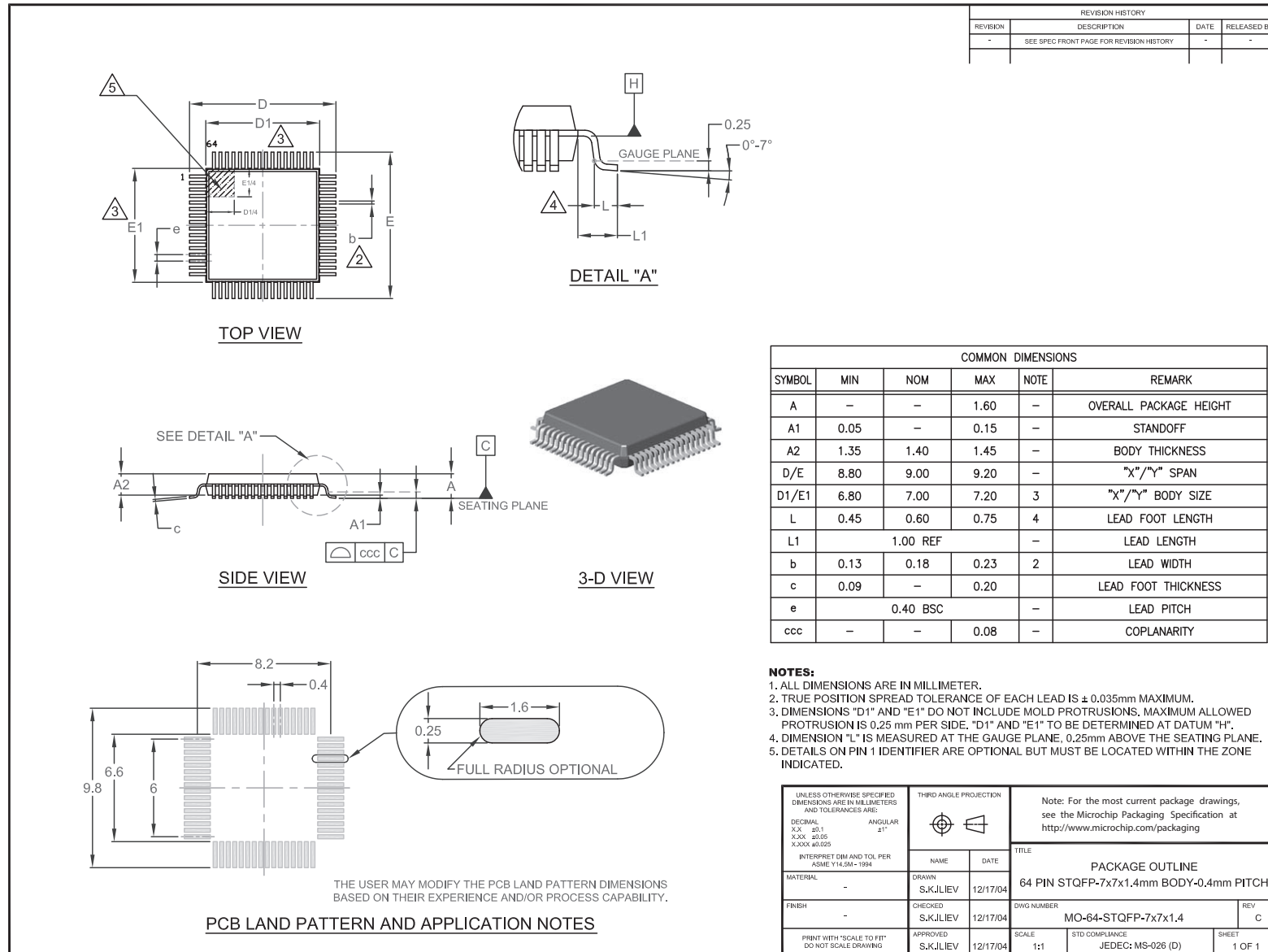

THE USER MAY MODIFY THE PCB LAND PATTERN DIMENSIONS BASED ON THEIR EXPERIENCE AND/OR PROCESS CAPABILITY.



**MICROCHIP**

---

---

**Legacy SMSC Packaging Outlines and Dimensions**

---

---

**NOTES:**



---

---

## Legacy SMSC Packaging Outlines and Dimensions

---

---

### **MQFP**

SMSC Legacy

## Legacy SMSC Packaging Outlines and Dimensions

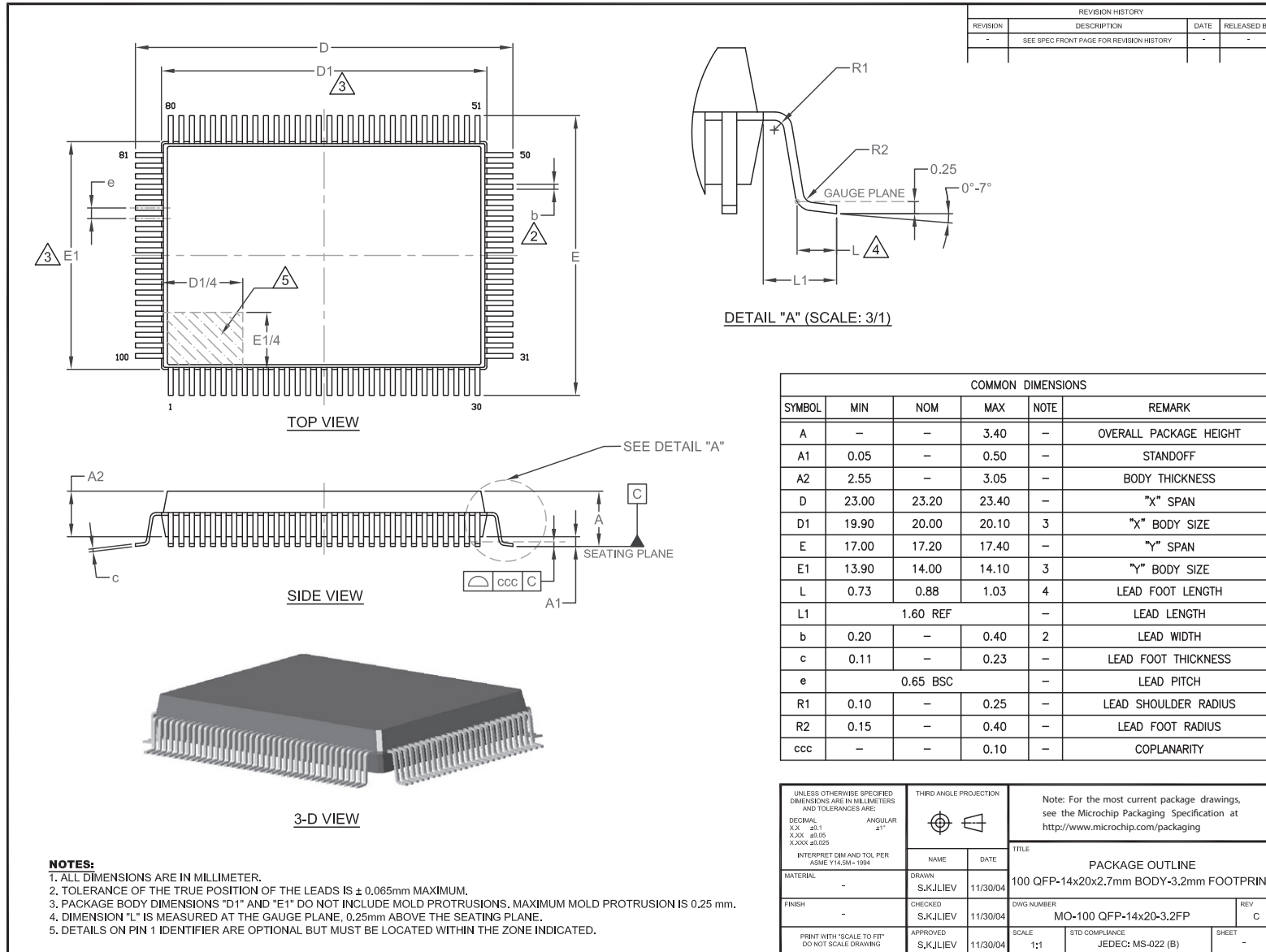

## Legacy SMSC Packaging Outlines and Dimensions

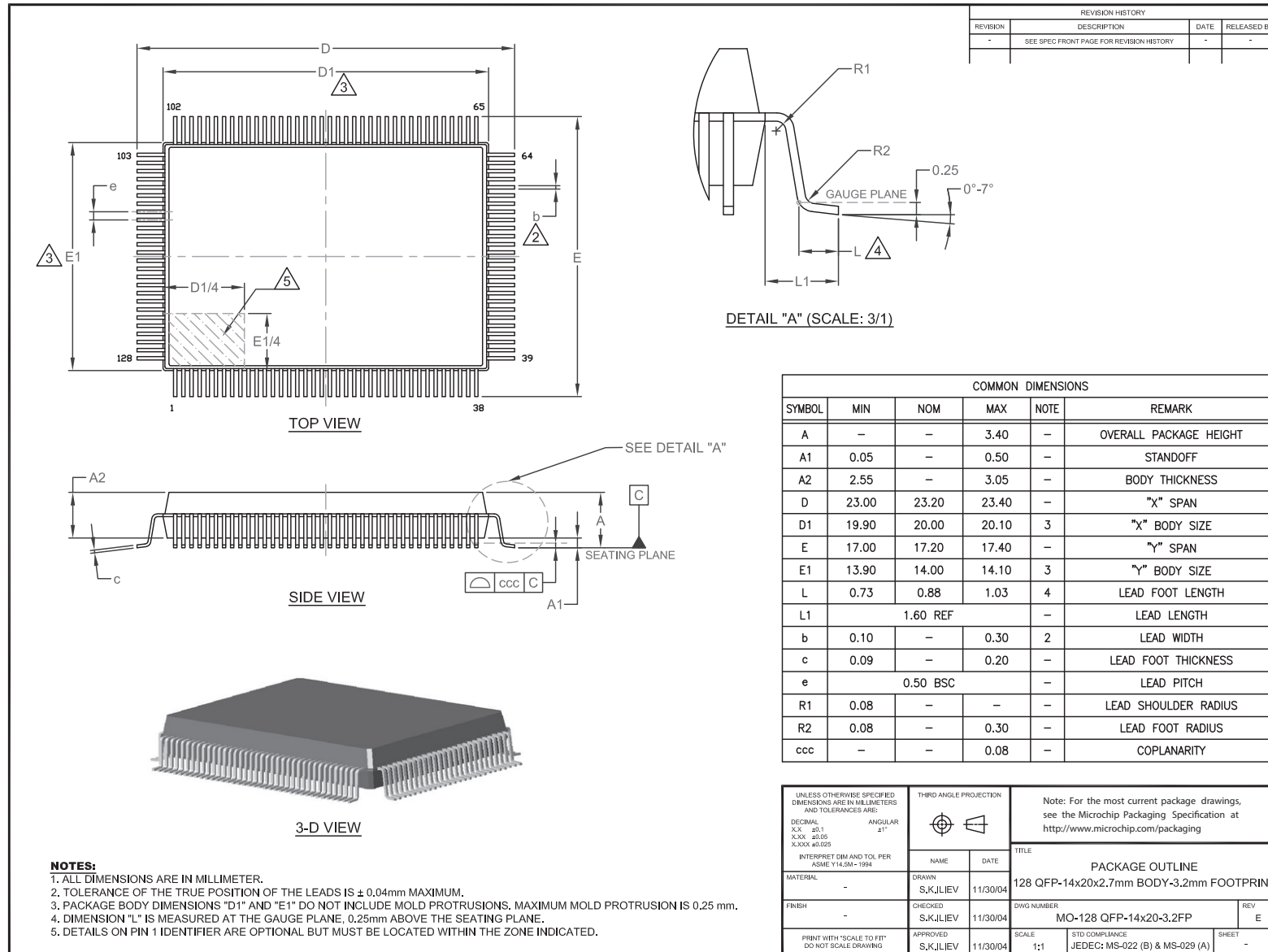



**MICROCHIP**

---

---

**Legacy SMSC Packaging Outlines and Dimensions**

---

---

**NOTES:**

---

---

## Legacy SMSC Packaging Outlines and Dimensions

---

---

### **PLCC**

SMSC Legacy

## Legacy SMSC Packaging Outlines and Dimensions

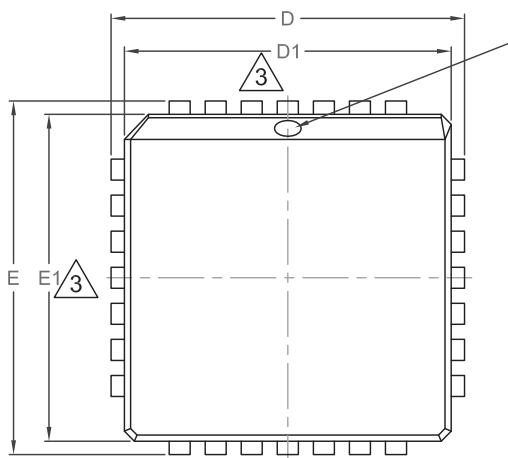

**TOP VIEW**

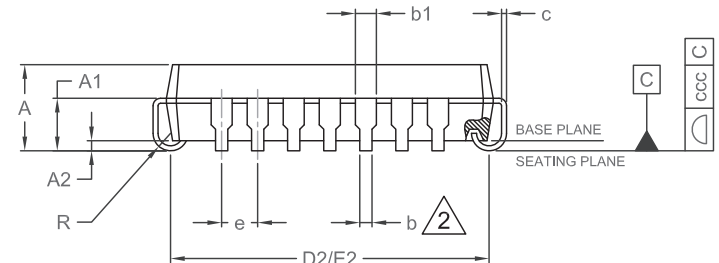

**SIDE VIEW**

REVISION HISTORY			
REV	DESCRIPTION	DATE	RELEASED BY
A	INITIAL RELEASE	4/26/01	S.K.ILIEV
B	NEW DWG LAYOUT, 3-D VIEW ADDED	3/09/05	S.K.ILIEV
C	REMOVED THE LOGO FROM THE TITLE BLOCK	9/25/07	S.K.ILIEV

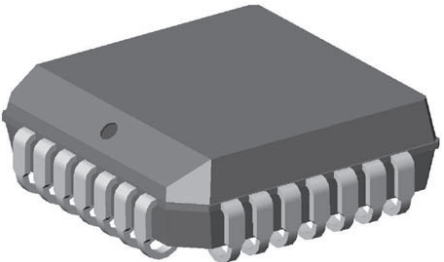
**3-D VIEW**

COMMON DIMENSIONS					
SYMBOL	MIN	NOM	MAX	NOTE	REMARK
A	0.165	–	0.180	–	OVERALL PKG HEIGHT
A1	0.090	–	0.120	–	LEAD HEIGHT
A2	0.020	–	–	–	STANDOFF
D/E	0.485	–	0.495	3	"X"/"Y" SPAN
D1/E1	0.450	0.453	0.456	3	"X"/"Y" BODY SIZE
D2/E2	0.390	–	0.430	–	LEAD CONTACT SPAN AT PLANE "C"
R	0.025	–	0.045	–	LEAD RADIUS AT PLANE "C"
e	0.050 BSC		–	–	LEAD PITCH
b	0.013	–	0.021	2	LEAD WIDTH AT PLANE "C"
b1	0.026	–	0.032	–	LEAD WIDTH AT PKG BODY/MOLD
c	0.010 TYP		–	–	LEAD THICKNESS
ccc	–	–	0.004	–	COPLANARITY

**NOTES:**

- ALL DIMENSIONS ARE IN INCHES.
- TRUE POSITION SPREAD TOLERANCE OF EACH LEAD IS  $\pm 0.0035$  inches AT MAXIMUM MATERIAL CONDITION.
- DIMENSIONS "D1" & "E1" DO NOT INCLUDE MOLD PROTRUSION. MAXIMUM ALLOWABLE MOLD PROTRUSION IS 0.010 inches PER SIDE.

UNLESS OTHERWISE SPECIFIED DIMENSIONS ARE IN MILLIMETERS AND TOLERANCES ARE:

DECIMAL	ANGULAR
XX ±0.1	±1°
X.XX ±0.05	
X.XXX ±0.025	

INTERPRET DIM AND TOL PER ASME Y14.5M - 1994

THIRD ANGLE PROJECTION



Note: For the most current package drawings, see the Microchip Packaging Specification at <http://www.microchip.com/packaging>

TITLE	
PACKAGE OUTLINE 28 PIN PLCC, 0.050 inch PITCH	
MATERIAL	DRAWN S.K.ILIEV 4/26/01
FINISH	CHECKED S.K.ILIEV 4/26/01
APPROVED S.K.ILIEV 4/26/01	DATE
DWG NUMBER AP-28-PLCC	
SCALE 1:1	STD COMPLIANCE JEDEC: MO-047
SHEET 1 OF 1	

---

---

## Legacy SMSC Packaging Outlines and Dimensions

---

---

### **QFN**

SMSC Legacy

## Legacy SMSC Packaging Outlines and Dimensions

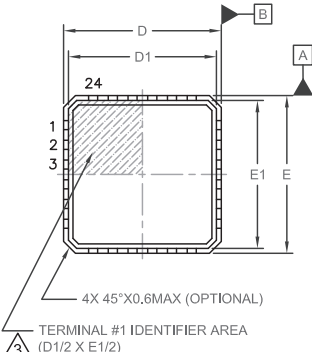

**TOP VIEW**

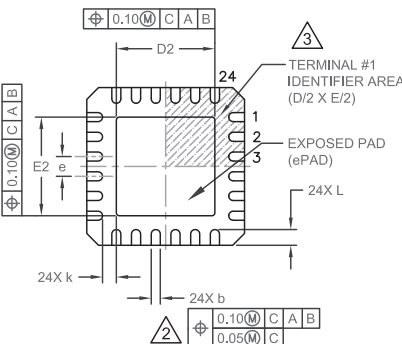

**BOTTOM VIEW**

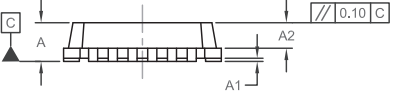

**SIDE VIEW**

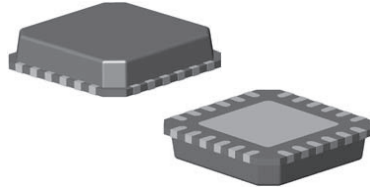

**3-D VIEWS**

REVISION HISTORY			
REV	DESCRIPTION	DATE	RELEASED BY
A	INITIAL RELEASE	4/6/06	S.K.ILIEV
B	ADDED PAGE 2of2, AND APP NOTES UPDATED. D/E TOLERANCE FROM ±0.15 TO ±0.10mm. ADDED DIM K, POSITION TOLERANCES SHOWN AT BOTTOM VIEW.	2/18/09	S.K.ILIEV
C	ADD K(NOM), AND RE-LAYOUT PAGE 2 of 2	6/10/09	S.K.ILIEV

COMMON DIMENSIONS					
SYMBOL	MIN	NOM	MAX	NOTE	REMARK
A	0.70	0.85	1.00	-	OVERALL PACKAGE HEIGHT
A1	0	0.02	0.05	-	STANDOFF
A2	-	-	0.90	-	MOLD CAP THICKNESS
D/E	3.90	4.00	4.10	-	X/Y BODY SIZE
D1/E1	3.55	3.75	3.95	-	X/Y MOLD CAP SIZE
D2/E2	2.40	2.50	2.60	-	X/Y EXPOSED PAD SIZE
L	0.30	0.40	0.50	-	TERMINAL LENGTH
b	0.18	0.25	0.30	2	TERMINAL WIDTH
k	0.25	0.35	-	-	PIN TO ePAD CLEARANCE
e	0.50 BSC		-	-	TERMINAL PITCH

**NOTES:**

- ALL DIMENSIONS ARE IN MILLIMETERS.
- DIMENSIONS "b" APPLIES TO PLATED TERMINALS AND IT IS MEASURED BETWEEN 0.15 AND 0.30 mm FROM THE TERMINAL TIP.
- DETAILS OF TERMINAL #1 IDENTIFIER ARE OPTIONAL BUT MUST BE LOCATED WITHIN THE AREA INDICATED.

UNLESS OTHERWISE SPECIFIED DIMENSIONS ARE IN MILLIMETERS AND TOLERANCES ARE:

DECIMAL  
XX ±0.1  
X.XX ±0.05  
X.XXX ±0.025

INTERPRET DIM AND TOL PER ASME Y14.5M - 1994

THIRD ANGLE PROJECTION

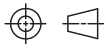

Note: For the most current package drawings, see the Microchip Packaging Specification at <http://www.microchip.com/packaging>

<b>TITLE</b>		<b>PACKAGE DATA</b>	
24 PINS QFN-2504, 4x4mm BODY, 0.5mm PITCH, 2.5x2.5mm EXPOSED PAD, 0.4mm LEAD LENGTH		<b>Package Outline Drawing (POD)</b>	
DWG NUMBER		REV	
24QFN-2504-4x4B		C	
SCALE	STD COMPLIANCE	SHEET	
1:1	JEDEC: MO-220	1 OF 2	



## Legacy SMSC Packaging Outlines and Dimensions

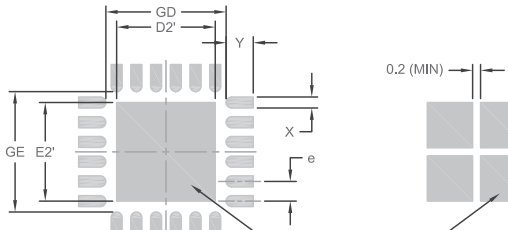

SEE NOTE 2

LAND PATTERN DIMENSIONS			
SYMBOL	MIN	NOM	MAX
GD/GE	3,05	-	3,10
D2/E2'	-	2,50	2,50
Pad: X	-	0,28	0,28
Pad: Y	-	0,69	-
e	-	0,50	-

**NOTES:**

1. THE USER MAY MODIFY THE PCB LAND PATTERN DESIGN AND DIMENSIONS BASED ON THEIR EXPERIENCE AND/OR PROCESS CAPABILITY.
2. EXPOSED SOLDERABLE COPPER AREA OF THE CENTER PAD CAN BE EITHER SOLID OR SEGMENTED.
3. MAXIMUM THERMAL AND ELECTRICAL PACKAGE PERFORMANCE IS ACHIEVED WHEN AN ARRAY OF SOLID VIAS IS INCORPORATED IN THE CENTER LAND PATTERN.

**PCB LAND PATTERN**

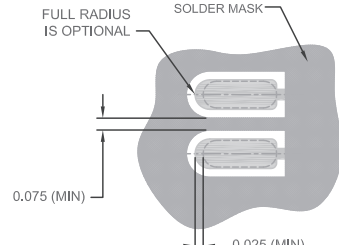

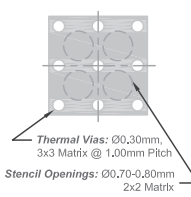

**DETAIL "A" - STENCIL OPENING for PERIMETER LANDS**

**OPTION 1**  
(NON-PLUGGED THERMAL VIAS)

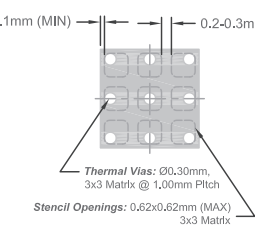

**OPTION 2**  
(PLUGGED THERMAL VIAS)





**DETAIL "B" - THERMAL VIAS and STENCIL OPENING for CENTER PAD**

REVISION HISTORY			
REV	DESCRIPTION	DATE	RELEASED BY
C	ADD K(NOM), AND RE-LAYOUT PAGE 2 of 2	6/10/09	S.K.ILIEV

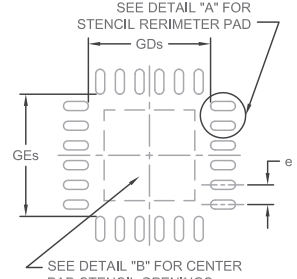

STENCIL DIMENSIONS			
SYMBOL	MIN	NOM	MAX
GDs/GEs	3,10	-	-
Xs	-	0,23	0,25
Ys	-	0,62	-
e	-	0,50	-

**STENCIL**

**SMT APPLICATION NOTES**

1. THE USER MAY MODIFY THE PCB LAND PATTERN DIMENSIONS BASED ON THEIR EXPERIENCE AND/OR PROCESS CAPABILITY.
2. THE LAND PATTERN CORRESPONDING TO THE PACKAGE EXPOSED PAD (IN THE CENTER) CAN BE LARGER, AND WITH DIFFERENT SHAPE THAN THE EXPOSED PAD ON THE PACKAGE. HOWEVER, THE SOLDERABLE AREA, AS DEFINED BY THE SOLDER MASK (SMD), OR NON SOLDER MASK DEFINED (NSMD), SHOULD BE AS SHOWN FOR THE BEST THERMAL & ELECTRICAL PERFORMANCE.
3. MAXIMUM THERMAL AND ELECTRICAL PERFORMANCE IS ACHIEVED WHEN AN ARRAY OF SOLID VIAS IS INCORPORATED IN THE CENTER LAND PATTERN (See Options 1 & 2).
4. THE VIAS SHOULD BE AT 0.8 to 1.2MM PITCH WITH 0.30 TO 0.40MM DIAMETER, AND 1 OZ COPPER VIA BARREL PLATING.
5. NON SOLDER MASK DEFINED (NSMD) PAD DESIGN IS RECOMMENDED FOR PERIMETER LANDS.
6. A LASER-CUT STAINLESS STEEL STENCIL IS RECOMMENDED WITH ELECTRO POLISHED TRAPEZOIDAL WALLS. THE RECOMMENDED STENCIL THICKNESS IS 0.125 mm FOR PITCHES 0,4 and 0,5 mm.
7. RECOMMENDED STENCIL AREA & ASPECT RATIOS ARE 0.66 & 1.5 (MIN) RESPECTIVELY.
8. RECOMMENDED STENCIL APERTURES ARE AS SHOWN.
9. IT IS RECOMMENDED TO USE "NO-CLEAN", TYPE 3 SOLDER PASTE.
10. THE REFLOW PROFILE DEPENDS ON THE EXACT SOLDER PASTE USED AND THE GIVEN BOARD DETAILS, SUCH AS GEOMETRY, COMPONENTS ETC.

UNLESS OTHERWISE SPECIFIED DIMENSIONS ARE IN MILLIMETERS AND TOLERANCES ARE:

DECIMAL	ANGULAR
X.X ±0,1	±1°
X.XX ±0,05	
X.XXX ±0,025	

INTERPRET DIM AND TOL PER ASME Y14,5M - 1994

THIRD ANGLE PROJECTION



Note: For the most current package drawings, see the Microchip Packaging Specification at <http://www.microchip.com/packaging>

TITLE		PACKAGE DATA	
24 PINS QFN-2504, 4x4mm BODY, 0.5mm PITCH, 2.5x2.5mm EXPOSED PAD, 0.4mm LEAD LENGTH		<b>Application Notes</b>	
MATERIAL	DRAWN	DWG NUMBER	REV
-	-	24QFN-2504-4x4B	C
FINISH	CHECKED	SCALE	STD COMPLIANCE
-	S.K.ILIEV	1:1	JEDEC: MO-220
PRINT WITH "SCALE TO FIT" DO NOT SCALE DRAWING	APPROVED	SHEET	
	S.K.ILIEV	2 OF 2	

## Legacy SMSC Packaging Outlines and Dimensions

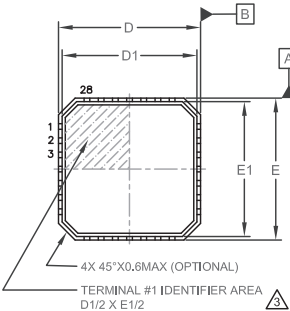

**TOP VIEW**

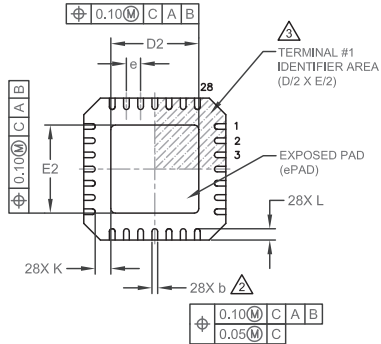

**BOTTOM VIEW**

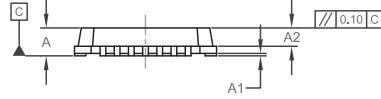

**SIDE VIEW**

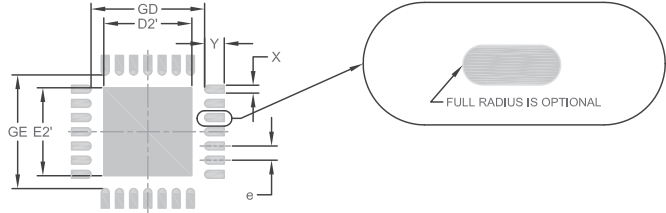

**3-D VIEWS**

REVISION HISTORY			
REV	DESCRIPTION	DATE	REL. BY
A	INITIAL RELEASE	8/20/09	S.K.JILIEV

COMMON DIMENSIONS					
SYMBOL	MIN	NOM	MAX	NOTE	REMARK
A	0.80	0.85	1.00	-	OVERALL PACKAGE HEIGHT
A1	0	0.02	0.05	-	STANDOFF
A2	0.60	-	0.80	-	MOLD CAP THICKNESS
D/E	4.90	5.00	5.10	-	X/Y BODY SIZE
D1/E1	4.55	4.75	4.95	-	X/Y MOLD CAP SIZE
D2/E2	3.00	3.10	3.20	-	X/Y EXPOSED PAD SIZE
L	0.30	0.40	0.50	-	TERMINAL LENGTH
b	0.18	0.25	0.30	2	TERMINAL WIDTH
K	0.45	0.55	-	-	TERMINAL TO ePAD CLEARANCE
e	0.50 BSC			-	TERMINAL PITCH

**NOTES:**

- ALL DIMENSIONS ARE IN MILLIMETER.
- DIMENSIONS "b" APPLIES TO PLATED TERMINALS AND IT IS MEASURED BETWEEN 0.15 AND 0.30 mm FROM THE TERMINAL TIP.
- DETAILS OF TERMINAL #1 IDENTIFIER ARE OPTIONAL BUT MUST BE LOCATED WITHIN THE AREA INDICATED.

LAND PATTERN DIMENSIONS			
SYMBOL	MIN	NOM	MAX
GD/GE	4.00	-	4.10
D2'/E2'	-	3.10	-
X	-	0.28	0.28
Y	-	0.69	-
e	0.50		

**PCB LAND PATTERN**

**PCB LAND NOTES:**

- THE USER MAY MODIFY THE PCB LAND PATTERN DESIGN AND DIMENSIONS BASED ON THEIR EXPERIENCE AND/OR PROCESS CAPABILITY
- EXPOSED SOLDERABLE COPPER AREA OF THE CENTER PAD CAN BE EITHER SOLID OR SEGMENTED
- MAXIMUM THERMAL AND ELECTRICAL PACKAGE PERFORMANCE IS ACHIEVED WHEN AN ARRAY OF SOLID VIAS IS INCORPORATED IN THE CENTER LAND PATTERN

UNLESS OTHERWISE SPECIFIED DIMENSIONS ARE IN MILLIMETERS AND TOLERANCES ARE:		THIRD ANGLE PROJECTION		Note: For the most current package drawings, see the Microchip Packaging Specification at <a href="http://www.microchip.com/packaging">http://www.microchip.com/packaging</a>
DECIMAL	ANGULAR	NAME	DATE	
X.X ±0.1	±1°			<b>TITLE</b> PACKAGE OUTLINE 28 PINS QFN-3104, 5x5mm BODY, 0.5mm PITCH 3.1x3.1mm ePAD, 0.4mm Lead Length
X.XX ±0.05				
X.XXX ±0.025				
INTERPRET DIM AND TOL PER ASME Y14.5M - 1994				
MATERIAL		DRAWN	8/14/09	
FINISH		CHECKED	8/17/09	
		APPROVED	8/20/09	
PRINT WITH "SCALE TO FIT" DO NOT SCALE DRAWING		SCALE	1:1	
		STD COMPLIANCE	JEDEC: MO-220	
		SHEET	1 OF 1	

## Legacy SMSC Packaging Outlines and Dimensions

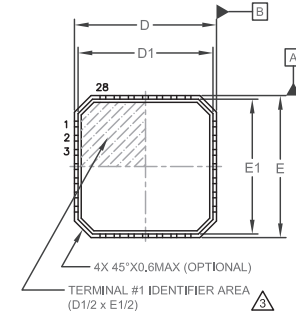

**TOP VIEW**

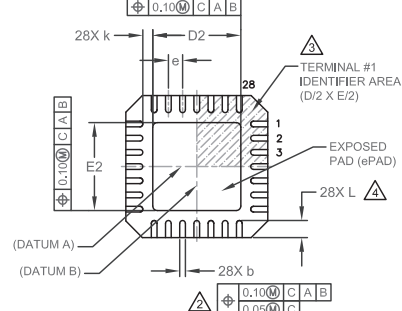

**BOTTOM VIEW**

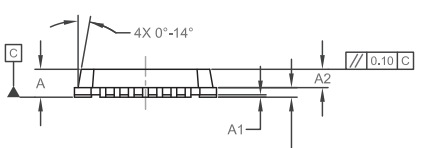

**SIDE VIEW**

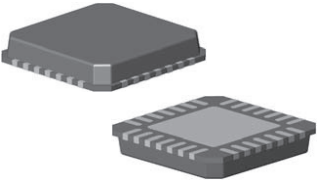

**3-D VIEWS**

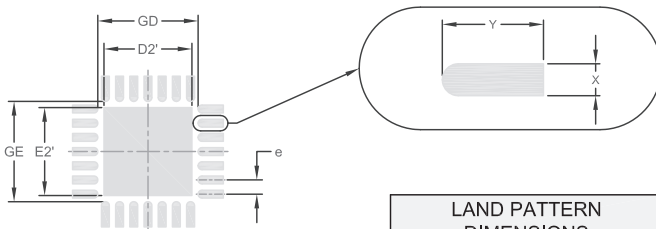

**PCB LAND PATTERN**

REVISION HISTORY			
REV	DESCRIPTION	DATE	REL. BY
A	INITIAL RELEASE	10/7/03	S.K.JLIEV
B	ADDING "PRELIMINARY" NOTE	12/1/03	S.K.JLIEV
C	REMOVE THE "PRELIMINARY" NOTE	12/14/04	S.K.JLIEV
D	NEW DRAWING FORMAT AND 3-D VIEW ADDED	12/20/04	S.K.JLIEV
E	D2/E2(MIN) FROM 1.25 TO 2.95 & (NOM) ADDED	6/21/05	S.K.JLIEV
F	RECOMMENDED PCB LAND PATTERN ADDED	4/20/06	S.K.JLIEV
G	ADDED PARALLELISM TOL, D2/E2' MAX, Y(nom) and X(nom), POSITION TOL MOVED TO TOP VIEW, SIDE ANGLE (max) FROM 12 TO 14°, D/E and D2/E2 TOL FROM ±0.15 TO ±0.10, GD/ED FROM 3.53 TO 3.65, Y(max) NOT SPECIFIED NOW	4/12/2011	SK1

COMMON DIMENSIONS					
SYMBOL	MIN	NOM	MAX	NOTE	REMARK
A	0.80	0.85	1.00	-	OVERALL PACKAGE HEIGHT
A1	0	0.02	0.05	-	STANDOFF
A2	0.60	0.65	0.80	-	MOLD CAP THICKNESS
A3	0.20 (REF)			-	LEADFRAME THICKNESS
D/E	4.90	5.00	5.10	-	X/Y BODY SIZE
D1/E1	4.55	4.75	4.95	-	X/Y MOLD CAP SIZE
D2/E2	3.00	3.10	3.20	2	X/Y EXPOSED PAD SIZE
L	0.50	0.60	0.75	4	TERMINAL LENGTH
b	0.18	0.25	0.30	2	TERMINAL WIDTH
e	0.50 BSC			-	TERMINAL PITCH

**NOTES:**

- ALL DIMENSIONS ARE IN MILLIMETER.
- DIMENSIONS "b" APPLIES TO PLATED TERMINALS AND IT IS MEASURED BETWEEN 0.15 AND 0.30 mm FROM THE TERMINAL TIP.
- DETAILS OF TERMINAL #1 IDENTIFIER ARE OPTIONAL BUT MUST BE LOCATED WITHIN THE AREA INDICATED.
- ROUNDED INNER TIPS ON TERMINALS ARE OPTIONAL.

LAND PATTERN DIMENSIONS			
SYMBOL	MIN	NOM	MAX
GD/GE	3.65	-	3.70
D2'/E2'	-	3.10	3.10
X	-	0.24	0.28
Y	-	0.89	-
e	0.50		

THE USER MAY MODIFY THE PCB LAND PATTERN DIMENSIONS BASED ON THEIR EXPERIENCE AND/OR PROCESS CAPABILITY

MAXIMUM THERMAL AND ELECTRICAL PACKAGE PERFORMANCE IS ACHIEVED WHEN AN ARRAY OF SOLID VIAS IS INCORPORATED IN THE CENTER LAND PATTERN

UNLESS OTHERWISE SPECIFIED DIMENSIONS ARE IN MILLIMETERS AND TOLERANCES ARE: DECIMAL      ANGULAR X.X      ±0.1 X.XX    ±0.05 X.XXX   ±0.025		THIRD ANGLE PROJECTION 		Note: For the most current package drawings, see the Microchip Packaging Specification at <a href="http://www.microchip.com/packaging">http://www.microchip.com/packaging</a>	
INTERPRET DIM AND TOL PER ASME Y14.5M - 1994		NAME	DATE	TITLE <b>PACKAGE DATA</b>	
MATERIAL	DRAWN	S.K.JLIEV	10/7/03	28 TERMINAL QFN, 5x5mm BODY, 0.5mm PITCH 3106 PCB FEATURES	
FINISH	CHECKED	S.K.JLIEV	10/7/03	DWG NUMBER	REV
PRINT WITH "SCALE TO FIT" DO NOT SCALE DRAWING	APPROVED	S.K.JLIEV	10/7/03	POD-28QFN-5x5B-05P-3106	G
SCALE		STD COMPLIANCE		SHEET	
1:1		JEDEC: MO-220		1 OF 1	

## Legacy SMSC Packaging Outlines and Dimensions

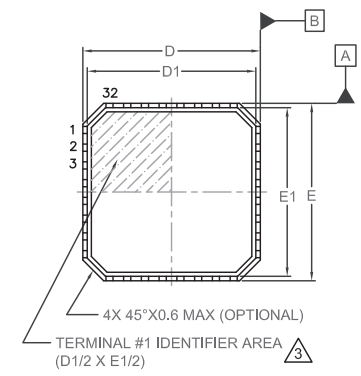

**TOP VIEW**

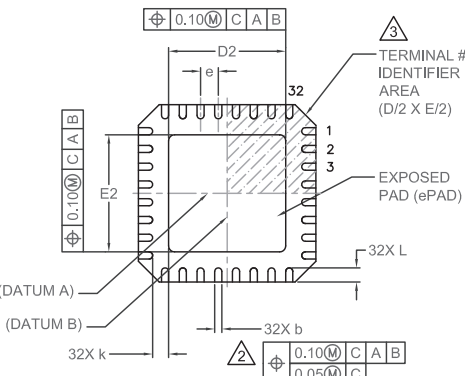

**BOTTOM VIEW**

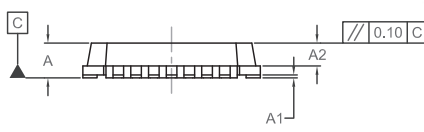

**SIDE VIEW**

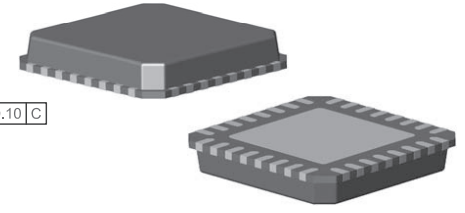

**3-D VIEWS**

REVISION HISTORY			
REV	DESCRIPTION	DATE	RELEASED BY
A	INITIAL RELEASE	10/30/08	S.K.ILIEV
B	L(MAX) FROM 0.55 TO 0.50mm. ADDED D2/E2 TABLE	7/8/05	S.K.ILIEV
C	D2/E2 FROM 2.95 - 3.10 - 3.25 TO 3.15 - 3.30 - 3.45	10/19/05	S.K.ILIEV
D	ADDED PCB LAND PATTERN. ADDED DIM "K"	11/18/08	S.K.ILIEV
E	ADDED PAGE 2of2, AND APP NOTES UPDATED. D/E and D2/E2 TOLERANCES FROM ±0.15 TO ±0.10mm. MINIMUM "K" FROM 0.20 TO 0.35mm	2/17/09	S.K.ILIEV
F	FIXED 3-D VIEWS from 28 to 32 PINS. ADDED K(nom). RE-LAYOUT PAGE 2of2.	4/23/09	S.K.ILIEV
G	D2/E2 (MIN) from 3.10 to 3.20.	9/1/09	S.K.ILIEV
H	ADDED A2 (NOM). ADDED D2/E2'(MIN). X from 0.28 to 0.24. Y from 0.69 to 0.75. Ys from 0.64 to 0.68.	10/7/10	S.K.ILIEV

**NOTES:**

- ALL DIMENSIONS ARE IN MILLIMETERS.
- DIMENSIONS "b" APPLIES TO PLATED TERMINALS AND IT IS MEASURED BETWEEN 0.15 AND 0.30 mm FROM THE TERMINAL TIP.
- DETAILS OF TERMINAL #1 IDENTIFIER ARE OPTIONAL BUT MUST BE LOCATED WITHIN THE AREA INDICATED.

COMMON DIMENSIONS					
SYMBOL	MIN	NOM	MAX	NOTE	REMARK
A	0.70	0.85	1.00	-	OVERALL PACKAGE HEIGHT
A1	0	0.02	0.05	-	STANDOFF
A2	-	0.65	0.90	-	MOLD CAP THICKNESS
D/E	4.90	5.00	5.10	-	X/Y BODY SIZE
D1/E1	4.55	4.75	4.95	-	X/Y MOLD CAP SIZE
D2/E2	3.20	3.30	3.40	-	X/Y EXPOSED PAD SIZE
L	0.30	0.40	0.50	-	TERMINAL LENGTH
b	0.18	0.25	0.30	2	TERMINAL WIDTH
k	0.35	0.45	-	-	TERMINAL TO ePAD CLEARANCE
e	0.50 BSC		-	-	TERMINAL PITCH

UNLESS OTHERWISE SPECIFIED DIMENSIONS ARE IN MILLIMETERS AND TOLERANCES ARE:

DECIMAL X.X ±0.1  
X.XX ±0.05  
X.XXX ±0.025

INTERPRET DIM AND TOL PER ASME Y14.5M - 1994

MATERIAL -

FINISH -

PRINT WITH "SCALE TO FIT" DO NOT SCALE DRAWING

THIRD ANGLE PROJECTION

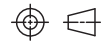

ANGULAR ±1°

NAME	DATE
DRAWN -	2/19/04
CHECKED S.K.ILIEV	2/19/04
APPROVED S.K.ILIEV	7/12/04

Note: For the most current package drawings, see the Microchip Packaging Specification at <http://www.microchip.com/packaging>

<b>TITLE</b> PACKAGE DATA 32 PINS QFN-3304, 5x5mm BODY, 0.5mm PITCH 3.3x3.3mm ePAD, 0.4mm LEAD LENGTH <b>Package Outline Drawing (POD)</b>	
DWG NUMBER <b>32QFN-3304-5x5B</b>	REV <b>H</b>
SCALE <b>1:1</b>	STD COMPLIANCE <b>JEDEC: MO-220</b>
SHEET <b>1 OF 2</b>	

## Legacy SMSC Packaging Outlines and Dimensions

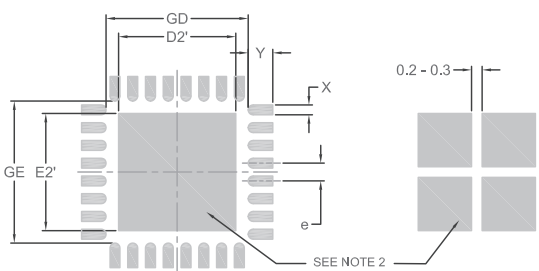

**PCB LAND PATTERN**

LAND PATTERN DIMENSIONS			
SYMBOL	MIN	NOM	MAX
GD/GE	4.00	-	4.10
D2'/E2'	3.10	-	3.30
X	-	0.24	0.28
Y	-	0.69	0.75
e	0.50		

**NOTES:**  
1. THE USER MAY MODIFY THE PCB LAND PATTERN DESIGN AND DIMENSIONS BASED ON THEIR EXPERIENCE AND/OR PROCESS CAPABILITY  
2. EXPOSED SOLDERABLE COPPER AREA OF THE CENTER PAD CAN BE EITHER SOLID OR SEGMENTED  
3. MAXIMUM THERMAL AND ELECTRICAL PACKAGE PERFORMANCE IS ACHIEVED WHEN AN ARRAY OF SOLID VIAS IS INCORPORATED IN THE CENTER LAND PATTERN

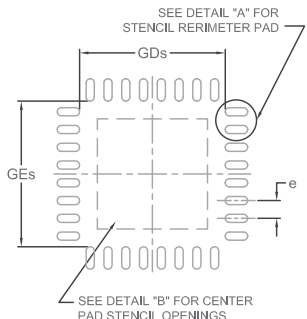

**STENCIL**

STENCIL DIMENSIONS			
SYMBOL	MIN	NOM	MAX
GDs/GEs	4.05	-	-
Xs	-	0.23	0.25
Ys	-	0.62	0.68
e	0.50		

**STENCIL APPLICATION NOTES**

- THE USER MAY MODIFY THE PCB LAND PATTERN DIMENSIONS BASED ON THEIR EXPERIENCE AND/OR PROCESS CAPABILITY.
- THE LAND PATTERN CORRESPONDING TO THE PACKAGE EXPOSED PAD (IN THE CENTER) CAN BE LARGER, AND WITH DIFFERENT SHAPE THAN THE EXPOSED PAD ON THE PACKAGE. HOWEVER, THE SOLDERABLE AREA, AS DEFINED BY THE SOLDER MASK (SMD), OR NON-SOLDER MASK DEFINED (NSMD), SHOULD BE AS SHOWN FOR THE BEST THERMAL & ELECTRICAL PERFORMANCE.
- MAXIMUM THERMAL AND ELECTRICAL PERFORMANCE IS ACHIEVED WHEN AN ARRAY OF SOLID VIAS IS INCORPORATED IN THE CENTER LAND PATTERN (See Options 1 & 2).
- THE VIAS SHOULD BE AT 0.8 TO 1.2MM PITCH WITH 0.30 TO 0.40MM DIAMETER, AND 1 OZ COPPER VIA BARREL PLATING.
- NON SOLDER MASK DEFINED (NSMD) PAD DESIGN IS RECOMMENDED FOR PERIMETER LANDS.
- A LASER-CUT STAINLESS STEEL STENCIL IS RECOMMENDED WITH ELECTRO POLISHED TRAPEZOIDAL WALLS. THE RECOMMENDED STENCIL THICKNESS IS 0.125 mm FOR PITCHES 0.4 and 0.5 mm.
- RECOMMENDED STENCIL AREA & ASPECT RATIOS ARE 0.66 & 1.5 (MIN) RESPECTIVELY.
- RECOMMENDED STENCIL APERTURES ARE AS SHOWN.
- IT IS RECOMMENDED TO USE "NO-CLEAN", TYPE 3 SOLDER PASTE.
- THE REFLOW PROFILE DEPENDS ON THE EXACT SOLDER PASTE USED AND THE GIVEN BOARD DETAILS, SUCH AS GEOMETRY, COMPONENTS ETC.

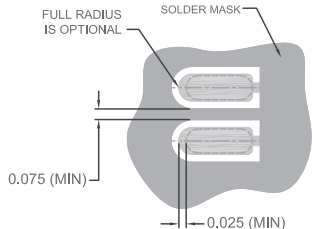

**DETAIL "A" - STENCIL OPENING for PERIMETER LANDS**

**OPTION 1**  
(NON-PLUGGED THERMAL VIAS)

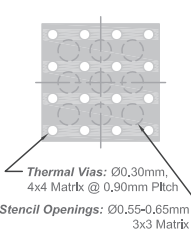

**OPTION 2**  
(PLUGGED THERMAL VIAS)

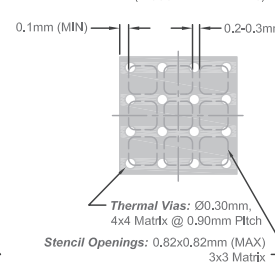

**DETAIL "B"**  
**THERMAL VIAS and STENCIL OPENING - CENTER PAD**

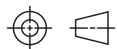
<p>UNLESS OTHERWISE SPECIFIED DIMENSIONS ARE IN MILLIMETERS AND TOLERANCES ARE:</p> <table style="width: 100%;"> <tr> <td>DECIMAL</td> <td>ANGULAR</td> </tr> <tr> <td>X.X ±0.1</td> <td>±1°</td> </tr> <tr> <td>X.XX ±0.05</td> <td></td> </tr> <tr> <td>X.XXX ±0.025</td> <td></td> </tr> </table> <p>INTERPRET DIM AND TOL PER ASME Y14.5M - 1994</p>	DECIMAL	ANGULAR	X.X ±0.1	±1°	X.XX ±0.05		X.XXX ±0.025		<b>THIRD ANGLE PROJECTION</b> 	<p>Note: For the most current package drawings, see the Microchip Packaging Specification at <a href="http://www.microchip.com/packaging">http://www.microchip.com/packaging</a></p>																																		
DECIMAL	ANGULAR																																											
X.X ±0.1	±1°																																											
X.XX ±0.05																																												
X.XXX ±0.025																																												
<table border="1" style="width: 100%; border-collapse: collapse;"> <tr> <td style="width: 30%;">MATERIAL</td> <td style="width: 30%;">DRAWN</td> <td style="width: 40%;">DATE</td> </tr> <tr> <td style="text-align: center;">-</td> <td style="text-align: center;">-</td> <td style="text-align: center;">2/17/09</td> </tr> <tr> <td style="vertical-align: top;">FINISH</td> <td style="vertical-align: top;">CHECKED</td> <td style="vertical-align: top;">DATE</td> </tr> <tr> <td style="text-align: center;">-</td> <td style="text-align: center;">-</td> <td style="text-align: center;">2/17/09</td> </tr> <tr> <td style="vertical-align: top;">PRINT WITH "SCALE TO FIT" DO NOT SCALE DRAWING</td> <td style="vertical-align: top;">APPROVED</td> <td style="vertical-align: top;">DATE</td> </tr> <tr> <td></td> <td style="text-align: center;">S.K.ILIEV</td> <td style="text-align: center;">2/17/09</td> </tr> </table>	MATERIAL	DRAWN	DATE	-	-	2/17/09	FINISH	CHECKED	DATE	-	-	2/17/09	PRINT WITH "SCALE TO FIT" DO NOT SCALE DRAWING	APPROVED	DATE		S.K.ILIEV	2/17/09	<table border="1" style="width: 100%; border-collapse: collapse;"> <tr> <td colspan="3" style="text-align: center;"><b>TITLE</b></td> </tr> <tr> <td colspan="3" style="text-align: center;"><b>PACKAGE DATA</b></td> </tr> <tr> <td colspan="3" style="text-align: center;">32 PINS QFN-3304, 5x5mm BODY, 0.5mm PITCH, 3.3x3.3mm EXPOSED PAD, 0.4mm LEAD LENGTH</td> </tr> <tr> <td colspan="3" style="text-align: center;"><b>Application Notes</b></td> </tr> <tr> <td style="width: 60%;">DWG NUMBER</td> <td style="width: 20%;">REV</td> <td style="width: 20%;"></td> </tr> <tr> <td style="text-align: center;">32QFN-3304-5x5B</td> <td style="text-align: center;">H</td> <td></td> </tr> <tr> <td>SCALE</td> <td>STD COMPLIANCE</td> <td>SHEET</td> </tr> <tr> <td style="text-align: center;">1:1</td> <td style="text-align: center;">JEDEC: MO-220</td> <td style="text-align: center;">2 OF 2</td> </tr> </table>		<b>TITLE</b>			<b>PACKAGE DATA</b>			32 PINS QFN-3304, 5x5mm BODY, 0.5mm PITCH, 3.3x3.3mm EXPOSED PAD, 0.4mm LEAD LENGTH			<b>Application Notes</b>			DWG NUMBER	REV		32QFN-3304-5x5B	H		SCALE	STD COMPLIANCE	SHEET	1:1	JEDEC: MO-220	2 OF 2
MATERIAL	DRAWN	DATE																																										
-	-	2/17/09																																										
FINISH	CHECKED	DATE																																										
-	-	2/17/09																																										
PRINT WITH "SCALE TO FIT" DO NOT SCALE DRAWING	APPROVED	DATE																																										
	S.K.ILIEV	2/17/09																																										
<b>TITLE</b>																																												
<b>PACKAGE DATA</b>																																												
32 PINS QFN-3304, 5x5mm BODY, 0.5mm PITCH, 3.3x3.3mm EXPOSED PAD, 0.4mm LEAD LENGTH																																												
<b>Application Notes</b>																																												
DWG NUMBER	REV																																											
32QFN-3304-5x5B	H																																											
SCALE	STD COMPLIANCE	SHEET																																										
1:1	JEDEC: MO-220	2 OF 2																																										

## Legacy SMSC Packaging Outlines and Dimensions

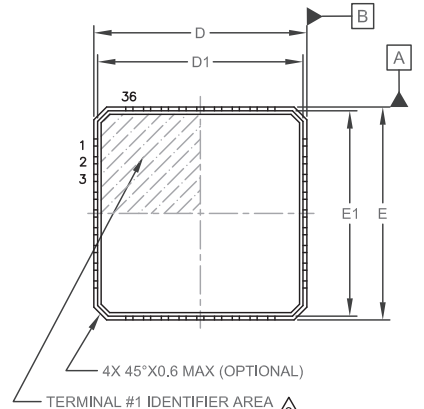

**TOP VIEW**

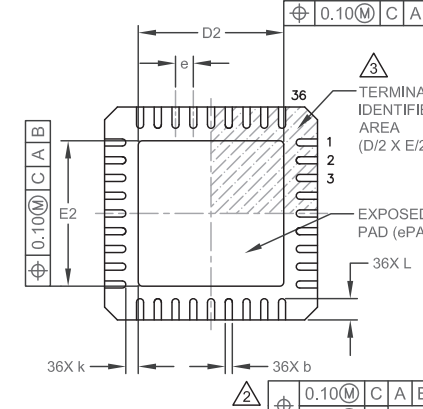

**BOTTOM VIEW**

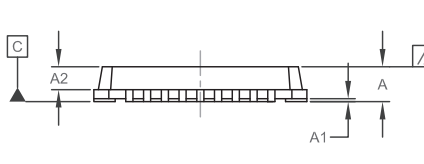

**SIDE VIEW**

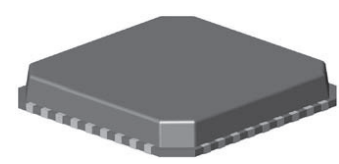
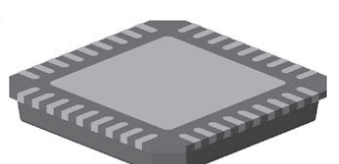
**3-D VIEWS**

REVISION HISTORY			
REV	DESCRIPTION	DATE	RELEASED BY
A	INITIAL RELEASE	7/24/07	S.K.ILIEV
B	"A" was 0.70-1.00, now 0.80-0.85-0.90. "A2" was -- 0.90, now - 0.65-0.75. D/E tolerance was ±0.15, now is ±0.10. ADDED PAGE 2of2. UPDATED APP NOTES	3/27/09	S.K.ILIEV

COMMON DIMENSIONS					
SYMBOL	MIN	NOM	MAX	NOTE	REMARK
A	0.80	0.85	0.90	-	OVERALL PACKAGE HEIGHT
A1	0	0.02	0.05	-	STANDOFF
A2	-	0.65	0.75	-	MOLD CAP THICKNESS
D/E	5.90	6.00	6.10	-	X/Y BODY SIZE
D1/E1	5.55	-	5.95	-	X/Y MOLD CAP SIZE
D2/E2	4.00	4.10	4.20	-	X/Y EXPOSED PAD SIZE
L	0.50	0.60	0.75	-	TERMINAL LENGTH
b	0.18	0.25	0.30	2	TERMINAL WIDTH
k	0.25	0.35	-	-	TERMINAL TO ePAD CLEARANCE
e	0.50 BSC			-	TERMINAL PITCH

**NOTES:**

1. ALL DIMENSIONS ARE IN MILLIMETERS.
2. DIMENSIONS "b" APPLIES TO PLATED TERMINALS AND IT IS MEASURED BETWEEN 0.15 AND 0.30 mm FROM THE TERMINAL TIP.
3. DETAILS OF TERMINAL #1 IDENTIFIER ARE OPTIONAL BUT MUST BE LOCATED WITHIN THE AREA INDICATED.

<small>UNLESS OTHERWISE SPECIFIED DIMENSIONS ARE IN MILLIMETERS AND TOLERANCES ARE:            DECIMAL X.X ±0.1            X.XX ±0.05            X.XXX ±0.025            INTERPRET DIM AND TOL PER ASME Y14.5M - 1994</small>	<small>THIRD ANGLE PROJECTION</small> 	<small>Note: For the most current package drawings, see the Microchip Packaging Specification at <a href="http://www.microchip.com/packaging">http://www.microchip.com/packaging</a></small>
<small>MATERIAL: -</small>	<small>NAME: -</small> <small>DATE: 7/20/07</small>	<small>TITLE: PACKAGE DATA</small> <small>36 PINS QFN-4106, 6x6mm BODY, 0.5mm PITCH, 4.1x4.1mm EXPOSED PAD, 0.6mm LEAD LENGTH</small> <small><b>Package Outline Drawing (POD)</b></small>
<small>FINISH: -</small>	<small>CHECKED: S.K.ILIEV</small> <small>7/24/07</small>	<small>DWG NUMBER: 36QFN-4106-6x6B</small> <small>REV: B</small>
<small>PRINT WITH "SCALE TO FIT" DO NOT SCALE DRAWING</small>	<small>APPROVED: S.K.ILIEV</small> <small>7/24/07</small>	<small>SCALE: 1:1</small> <small>STD COMPLIANCE: JEDEC: MO-220</small> <small>SHEET: 1 OF 2</small>

## Legacy SMSC Packaging Outlines and Dimensions

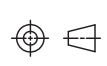

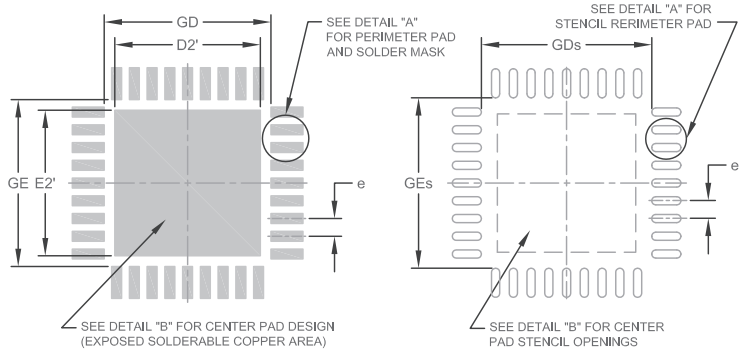
**PCB LAND PATTERN**

**STENCIL**

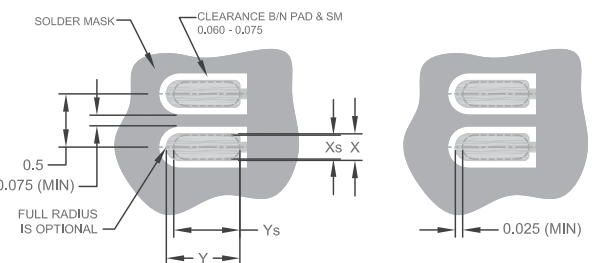

**DETAIL "A"**

**STENCIL OPENING - PERIMETER LANDS**

**OPTION 1**  
(NON-PLUGGED THERMAL VIAS)

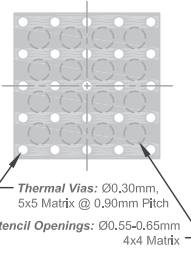

**Thermal Vias:** Ø0.30mm,  
5x5 Matrix @ 0.90mm Pitch  
**Stencil Openings:** Ø0.55-0.65mm  
4x4 Matrix

**OPTION 2**  
(PLUGGED THERMAL VIAS)

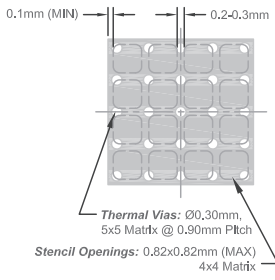

**Thermal Vias:** Ø0.30mm,  
5x5 Matrix @ 0.90mm Pitch  
**Stencil Openings:** 0.82x0.82mm (MAX)  
4x4 Matrix

**DETAIL "B"**

**THERMAL VIAS and STENCIL OPENING - CENTER PAD**

REVISION HISTORY			
REV	DESCRIPTION	DATE	RELEASED BY
B	"A" was 0.70-1.00, now 0.80-0.85-0.90, "A2" was -- 0.90, now - 0.65-0.75. D/E tolerance was ±0.15, now is ±0.10. ADDED PAGE 2of2. UPDATED APP NOTES	3/27/09	S.K.ILIEV

  

LAND PATTERN DIMENSIONS			
SYMBOL	MIN	NOM	MAX
GD/GE	4.70	-	4.75
GDs/GEs	4.80	-	-
D2'/E2'	-	4.10	4.10
Pad: X	-	0.28	0.28
Stencil: Xs	-	0.23	0.25
Pad: Y	-	0.90	0.90
Stencil: Ys	-	0.82	0.84
e	0.50		

**SMT APPLICATION NOTES**

1. THE USER MAY MODIFY THE PCB LAND PATTERN DIMENSIONS BASED ON THEIR EXPERIENCE AND/OR PROCESS CAPABILITY.
2. THE LAND PATTERN CORRESPONDING TO THE PACKAGE EXPOSED PAD (IN THE CENTER) CAN BE LARGER, AND WITH DIFFERENT SHAPE THAN THE EXPOSED PAD ON THE PACKAGE. HOWEVER, THE SOLDERABLE AREA, AS DEFINED BY THE SOLDER MASK (SMD), OR NON-SOLDER MASK DEFINED (NSMD), SHOULD BE AS SHOWN FOR THE BEST THERMAL & ELECTRICAL PERFORMANCE.
3. MAXIMUM THERMAL AND ELECTRICAL PERFORMANCE IS ACHIEVED WHEN AN ARRAY OF SOLID VIAS IS INCORPORATED IN THE CENTER LAND PATTERN (See Options 1 & 2).
4. THE VIAS SHOULD BE AT 0.8 TO 1.2MM PITCH WITH 0.30 TO 0.40MM DIAMETER, AND 1 OZ COPPER VIA BARREL PLATING.
5. NON SOLDER MASK DEFINED (NSMD) PAD DESIGN IS RECOMMENDED FOR PERIMETER LANDS.
6. A LASER-CUT STAINLESS STEEL STENCIL IS RECOMMENDED WITH ELECTRO POLISHED TRAPEZOIDAL WALLS. THE RECOMMENDED STENCIL THICKNESS IS 0.125 mm FOR PITCHES 0.4 and 0.5 mm.
7. RECOMMENDED STENCIL AREA & ASPECT RATIOS ARE 0.66 & 1.5 (MIN) RESPECTIVELY.
8. RECOMMENDED STENCIL APERTURES ARE AS SHOWN.
9. IT IS RECOMMENDED TO USE "NO-CLEAN", TYPE 3 SOLDER PASTE.
10. THE REFLOW PROFILE DEPENDS ON THE EXACT SOLDER PASTE USED AND THE GIVEN BOARD DETAILS, SUCH AS GEOMETRY, COMPONENTS ETC.

<p>UNLESS OTHERWISE SPECIFIED DIMENSIONS ARE IN MILLIMETERS AND TOLERANCES ARE:</p> <table style="width: 100%;"> <tr> <td style="width: 50%;">DECIMAL</td> <td style="width: 50%;">ANGULAR</td> </tr> <tr> <td>X.X ±0.1</td> <td>±1°</td> </tr> <tr> <td>X.XX ±0.05</td> <td></td> </tr> <tr> <td>X.XXX ±0.025</td> <td></td> </tr> </table> <p>INTERPRET DIM AND TOL PER ASME Y14.5M - 1994</p>	DECIMAL	ANGULAR	X.X ±0.1	±1°	X.XX ±0.05		X.XXX ±0.025		<p>THIRD ANGLE PROJECTION</p> 	<p>Note: For the most current package drawings, see the Microchip Packaging Specification at <a href="http://www.microchip.com/packaging">http://www.microchip.com/packaging</a></p>																									
DECIMAL	ANGULAR																																		
X.X ±0.1	±1°																																		
X.XX ±0.05																																			
X.XXX ±0.025																																			
<table border="1" style="width: 100%; border-collapse: collapse;"> <tr> <td style="width: 30%;">MATERIAL</td> <td style="width: 30%;">DRAWN</td> <td style="width: 40%;">DATE</td> </tr> <tr> <td style="text-align: center;">-</td> <td style="text-align: center;">-</td> <td style="text-align: center;">3/25/09</td> </tr> <tr> <td style="vertical-align: top;">FINISH</td> <td style="vertical-align: top;">CHECKED</td> <td style="vertical-align: top;">DATE</td> </tr> <tr> <td style="text-align: center;">-</td> <td style="text-align: center;">S.K.ILIEV</td> <td style="text-align: center;">3/27/09</td> </tr> <tr> <td style="vertical-align: top;">PRINT WITH "SCALE TO FIT" DO NOT SCALE DRAWING</td> <td style="vertical-align: top;">APPROVED</td> <td style="vertical-align: top;">DATE</td> </tr> <tr> <td></td> <td style="text-align: center;">S.K.ILIEV</td> <td style="text-align: center;">3/27/09</td> </tr> </table>	MATERIAL	DRAWN	DATE	-	-	3/25/09	FINISH	CHECKED	DATE	-	S.K.ILIEV	3/27/09	PRINT WITH "SCALE TO FIT" DO NOT SCALE DRAWING	APPROVED	DATE		S.K.ILIEV	3/27/09	<table border="1" style="width: 100%; border-collapse: collapse;"> <tr> <td colspan="2" style="text-align: center;">TITLE</td> </tr> <tr> <td colspan="2" style="text-align: center;">PACKAGE DATA</td> </tr> <tr> <td colspan="2" style="text-align: center;">36 PINS QFN-4106, 6x6mm BODY, 0.5mm PITCH, 4.1x4.1mm EXPOSED PAD, 0.6mm LEAD LENGTH</td> </tr> <tr> <td colspan="2" style="text-align: center;"><b>Application Notes</b></td> </tr> <tr> <td style="width: 70%;">DWG NUMBER</td> <td style="width: 30%;">REV</td> </tr> <tr> <td style="text-align: center;">36QFN-4106-6x6B</td> <td style="text-align: center;">B</td> </tr> <tr> <td>SCALE</td> <td>SHEET</td> </tr> <tr> <td style="text-align: center;">1:1</td> <td style="text-align: center;">2 OF 2</td> </tr> </table>	TITLE		PACKAGE DATA		36 PINS QFN-4106, 6x6mm BODY, 0.5mm PITCH, 4.1x4.1mm EXPOSED PAD, 0.6mm LEAD LENGTH		<b>Application Notes</b>		DWG NUMBER	REV	36QFN-4106-6x6B	B	SCALE	SHEET	1:1	2 OF 2
MATERIAL	DRAWN	DATE																																	
-	-	3/25/09																																	
FINISH	CHECKED	DATE																																	
-	S.K.ILIEV	3/27/09																																	
PRINT WITH "SCALE TO FIT" DO NOT SCALE DRAWING	APPROVED	DATE																																	
	S.K.ILIEV	3/27/09																																	
TITLE																																			
PACKAGE DATA																																			
36 PINS QFN-4106, 6x6mm BODY, 0.5mm PITCH, 4.1x4.1mm EXPOSED PAD, 0.6mm LEAD LENGTH																																			
<b>Application Notes</b>																																			
DWG NUMBER	REV																																		
36QFN-4106-6x6B	B																																		
SCALE	SHEET																																		
1:1	2 OF 2																																		

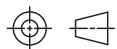

## Legacy SMSC Packaging Outlines and Dimensions

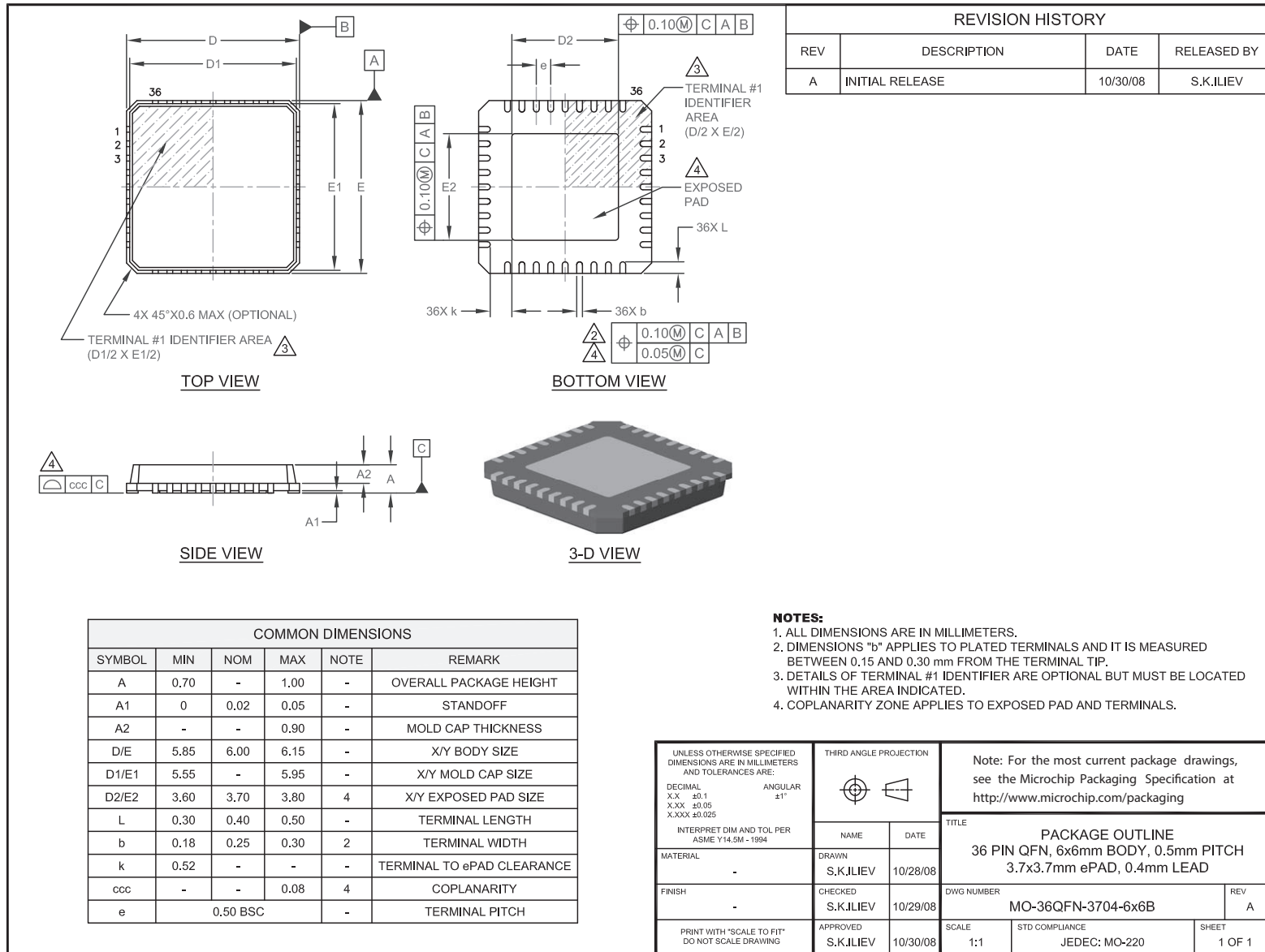



## Legacy SMSC Packaging Outlines and Dimensions

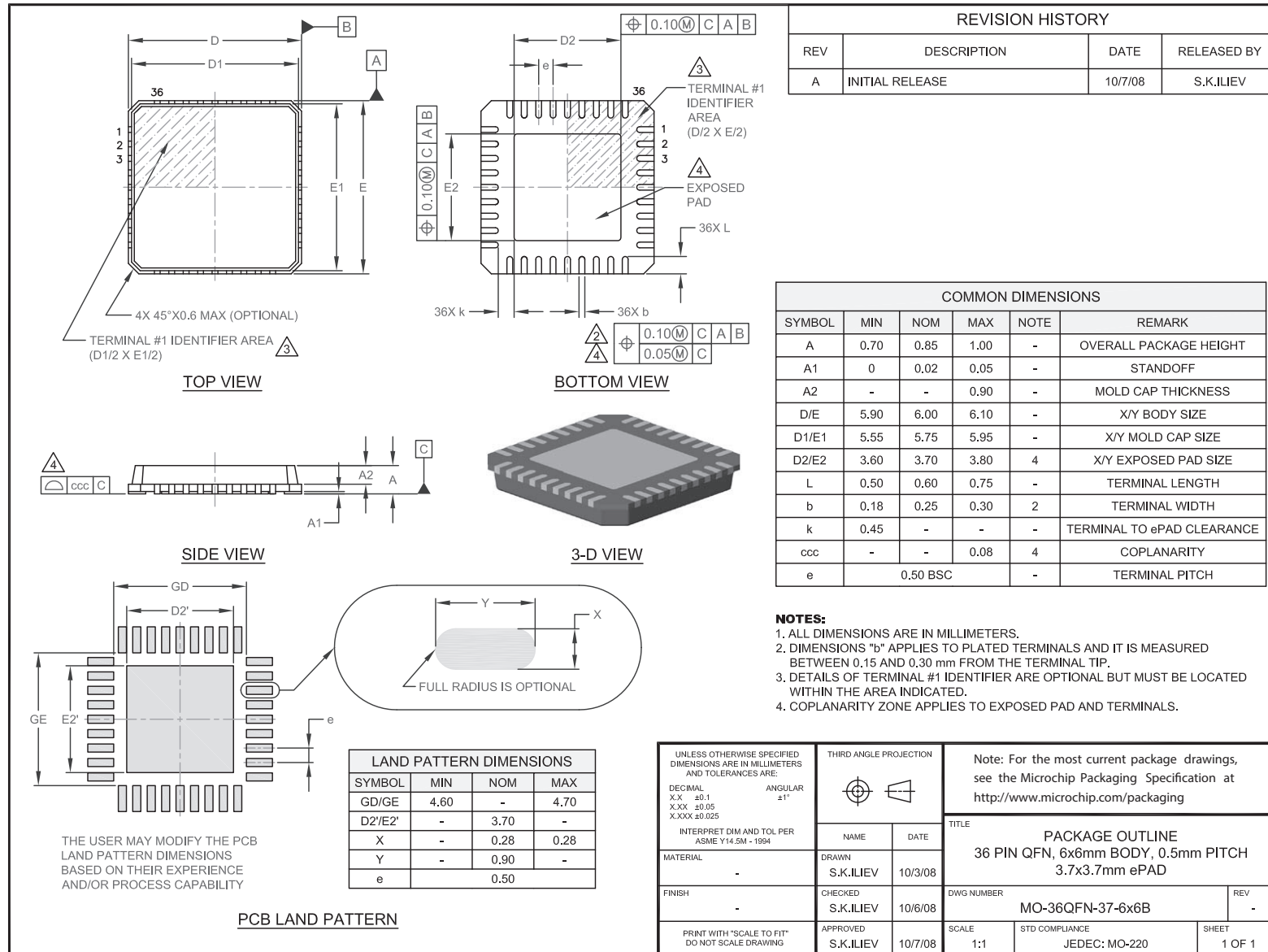

## Legacy SMSC Packaging Outlines and Dimensions

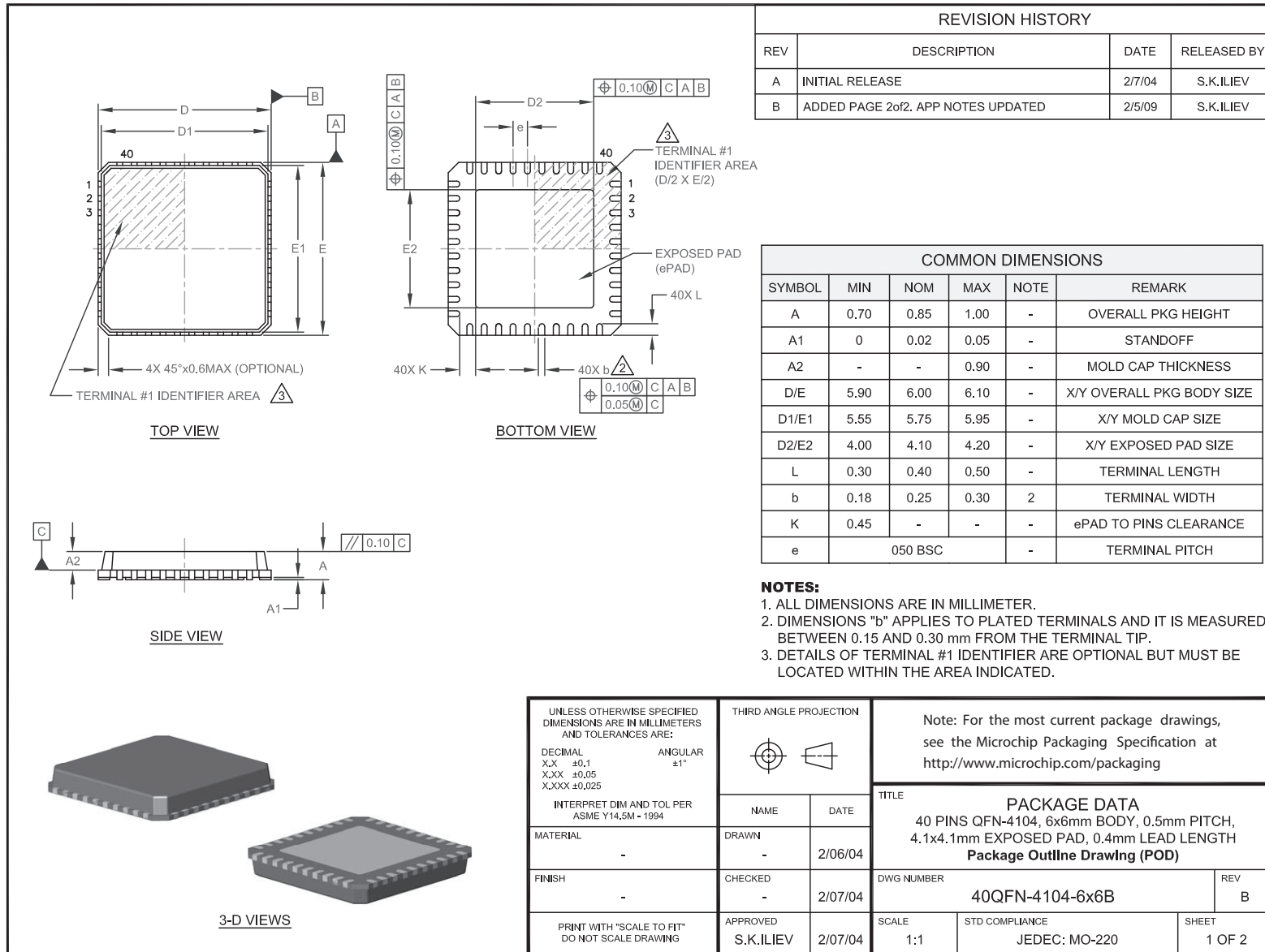

## Legacy SMSC Packaging Outlines and Dimensions

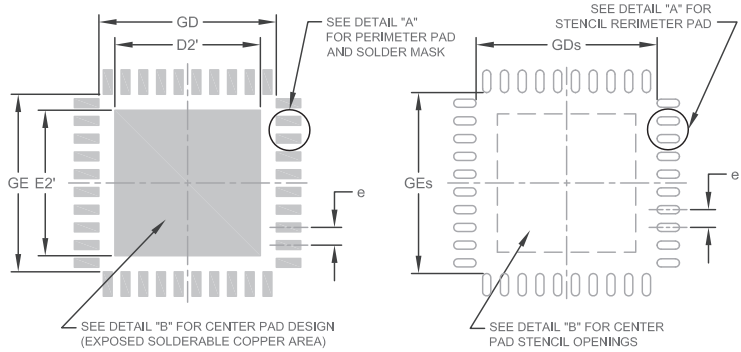

**PCB LAND PATTERN**

**STENCIL**

REVISION HISTORY			
REV	DESCRIPTION	DATE	RELEASED BY
B	ADDED PAGE 2of2. APP NOTES UPDATED	2/5/09	S.K.ILIEV

  

LAND PATTERN DIMENSIONS			
SYMBOL	MIN	NOM	MAX
GD/GE	5.00	-	5.10
GDs/GEs	5.05	-	-
D2'/E2'	-	4.10	-
Pad: X	-	0.28	0.28
Stencil: Xs	-	0.23	0.25
Pad: Y	-	0.69	0.69
Stencil: Ys	-	0.62	0.64
e	-	0.50	-

**SMT APPLICATION NOTES**

1. THE USER MAY MODIFY THE PCB LAND PATTERN DIMENSIONS BASED ON THEIR EXPERIENCE AND/OR PROCESS CAPABILITY.
2. THE LAND PATTERN CORRESPONDING TO THE PACKAGE EXPOSED PAD (IN THE CENTER) CAN BE LARGER, AND WITH DIFFERENT SHAPE THAN THE EXPOSED PAD ON THE PACKAGE. HOWEVER, THE SOLDERABLE AREA, AS DEFINED BY THE SOLDER MASK (SMD), OR NON-SOLDER MASK DEFINED (NSMD), SHOULD BE AS SHOWN FOR THE BEST THERMAL & ELECTRICAL PERFORMANCE.
3. MAXIMUM THERMAL AND ELECTRICAL PERFORMANCE IS ACHIEVED WHEN AN ARRAY OF SOLID VIAS IS INCORPORATED IN THE CENTER LAND PATTERN (See Options 1 & 2).
4. THE VIAS SHOULD BE AT 0.8 TO 1.2MM PITCH WITH 0.30 TO 0.40MM DIAMETER, AND 1 OZ COPPER VIA BARREL PLATING.
5. NON SOLDER MASK DEFINED (NSMD) PAD DESIGN IS RECOMMENDED FOR PERIMETER LANDS.
6. A LASER-CUT STAINLESS STEEL STENCIL IS RECOMMENDED WITH ELECTRO POLISHED TRAPEZOIDAL WALLS. THE RECOMMENDED STENCIL THICKNESS IS 0.125 mm FOR PITCHES 0.4 and 0.5 mm.
7. RECOMMENDED STENCIL AREA & ASPECT RATIOS ARE 0.66 & 1.5 (MIN) RESPECTIVELY.
8. RECOMMENDED STENCIL APERTURES ARE AS SHOWN.
9. IT IS RECOMMENDED TO USE "NO-CLEAN", TYPE 3 SOLDER PASTE.
10. THE REFLOW PROFILE DEPENDS ON THE EXACT SOLDER PASTE USED AND THE GIVEN BOARD DETAILS, SUCH AS GEOMETRY, COMPONENTS ETC.

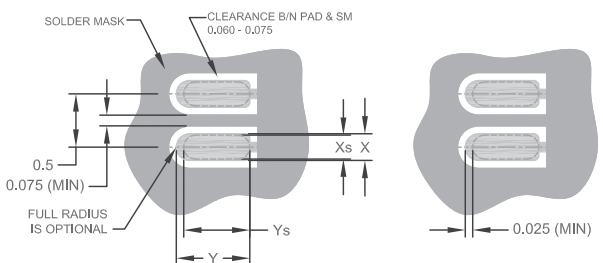

**DETAIL "A"**

**STENCIL OPENING - PERIMETER LANDS**

**OPTION 1**  
(NON-PLUGGED THERMAL VIAS)

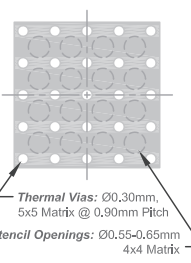

**Thermal Vias:** Ø0.30mm,  
5x5 Matrix @ 0.90mm Pitch  
**Stencil Openings:** Ø0.55-0.65mm  
4x4 Matrix

**OPTION 2**  
(PLUGGED THERMAL VIAS)

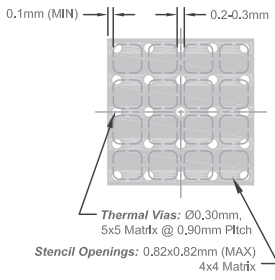

**Thermal Vias:** Ø0.30mm,  
5x5 Matrix @ 0.90mm Pitch  
**Stencil Openings:** 0.82x0.82mm (MAX)  
4x4 Matrix

**DETAIL "B"**

**THERMAL VIAS and STENCIL OPENING - CENTER PAD**

<p>UNLESS OTHERWISE SPECIFIED DIMENSIONS ARE IN MILLIMETERS AND TOLERANCES ARE:</p> <table style="width: 100%;"> <tr> <td style="width: 50%;">DECIMAL</td> <td style="width: 50%;">ANGULAR</td> </tr> <tr> <td>X.X ±0.1</td> <td>±1°</td> </tr> <tr> <td>X.XX ±0.05</td> <td></td> </tr> <tr> <td>X.XXX ±0.025</td> <td></td> </tr> </table> <p>INTERPRET DIM AND TOL PER ASME Y14.5M - 1994</p>	DECIMAL	ANGULAR	X.X ±0.1	±1°	X.XX ±0.05		X.XXX ±0.025		<p>THIRD ANGLE PROJECTION</p> 	<p>Note: For the most current package drawings, see the Microchip Packaging Specification at <a href="http://www.microchip.com/packaging">http://www.microchip.com/packaging</a></p>																									
DECIMAL	ANGULAR																																		
X.X ±0.1	±1°																																		
X.XX ±0.05																																			
X.XXX ±0.025																																			
<table border="1" style="width: 100%; border-collapse: collapse;"> <tr> <td style="width: 30%;">MATERIAL</td> <td style="width: 30%;">DRAWN</td> <td style="width: 40%;">DATE</td> </tr> <tr> <td style="text-align: center;">-</td> <td style="text-align: center;">-</td> <td style="text-align: center;">2/06/04</td> </tr> <tr> <td style="vertical-align: top;">FINISH</td> <td style="vertical-align: top;">CHECKED</td> <td style="vertical-align: top;">DATE</td> </tr> <tr> <td style="text-align: center;">-</td> <td style="text-align: center;">-</td> <td style="text-align: center;">2/07/04</td> </tr> <tr> <td style="vertical-align: top;">PRINT WITH "SCALE TO FIT" DO NOT SCALE DRAWING</td> <td style="vertical-align: top;">APPROVED</td> <td style="vertical-align: top;">DATE</td> </tr> <tr> <td></td> <td style="text-align: center;">S.K.ILIEV</td> <td style="text-align: center;">2/07/04</td> </tr> </table>	MATERIAL	DRAWN	DATE	-	-	2/06/04	FINISH	CHECKED	DATE	-	-	2/07/04	PRINT WITH "SCALE TO FIT" DO NOT SCALE DRAWING	APPROVED	DATE		S.K.ILIEV	2/07/04	<table border="1" style="width: 100%; border-collapse: collapse;"> <tr> <td colspan="2" style="text-align: center;">TITLE</td> </tr> <tr> <td colspan="2" style="text-align: center;">PACKAGE DATA</td> </tr> <tr> <td colspan="2" style="text-align: center;">40 PINS QFN-4104, 6x6mm BODY, 0.5mm PITCH, 4.1x4.1mm EXPOSED PAD, 0.4mm LEAD LENGTH</td> </tr> <tr> <td colspan="2" style="text-align: center;"><b>Application Notes</b></td> </tr> <tr> <td style="width: 70%;">DWG NUMBER</td> <td style="width: 30%;">REV</td> </tr> <tr> <td style="text-align: center;">40QFN-4104-6x6B</td> <td style="text-align: center;">B</td> </tr> <tr> <td>SCALE</td> <td>SHEET</td> </tr> <tr> <td style="text-align: center;">1:1</td> <td style="text-align: center;">2 OF 2</td> </tr> </table>	TITLE		PACKAGE DATA		40 PINS QFN-4104, 6x6mm BODY, 0.5mm PITCH, 4.1x4.1mm EXPOSED PAD, 0.4mm LEAD LENGTH		<b>Application Notes</b>		DWG NUMBER	REV	40QFN-4104-6x6B	B	SCALE	SHEET	1:1	2 OF 2
MATERIAL	DRAWN	DATE																																	
-	-	2/06/04																																	
FINISH	CHECKED	DATE																																	
-	-	2/07/04																																	
PRINT WITH "SCALE TO FIT" DO NOT SCALE DRAWING	APPROVED	DATE																																	
	S.K.ILIEV	2/07/04																																	
TITLE																																			
PACKAGE DATA																																			
40 PINS QFN-4104, 6x6mm BODY, 0.5mm PITCH, 4.1x4.1mm EXPOSED PAD, 0.4mm LEAD LENGTH																																			
<b>Application Notes</b>																																			
DWG NUMBER	REV																																		
40QFN-4104-6x6B	B																																		
SCALE	SHEET																																		
1:1	2 OF 2																																		
STD COMPLIANCE		JEDEC: MO-220																																	

## Legacy SMSC Packaging Outlines and Dimensions

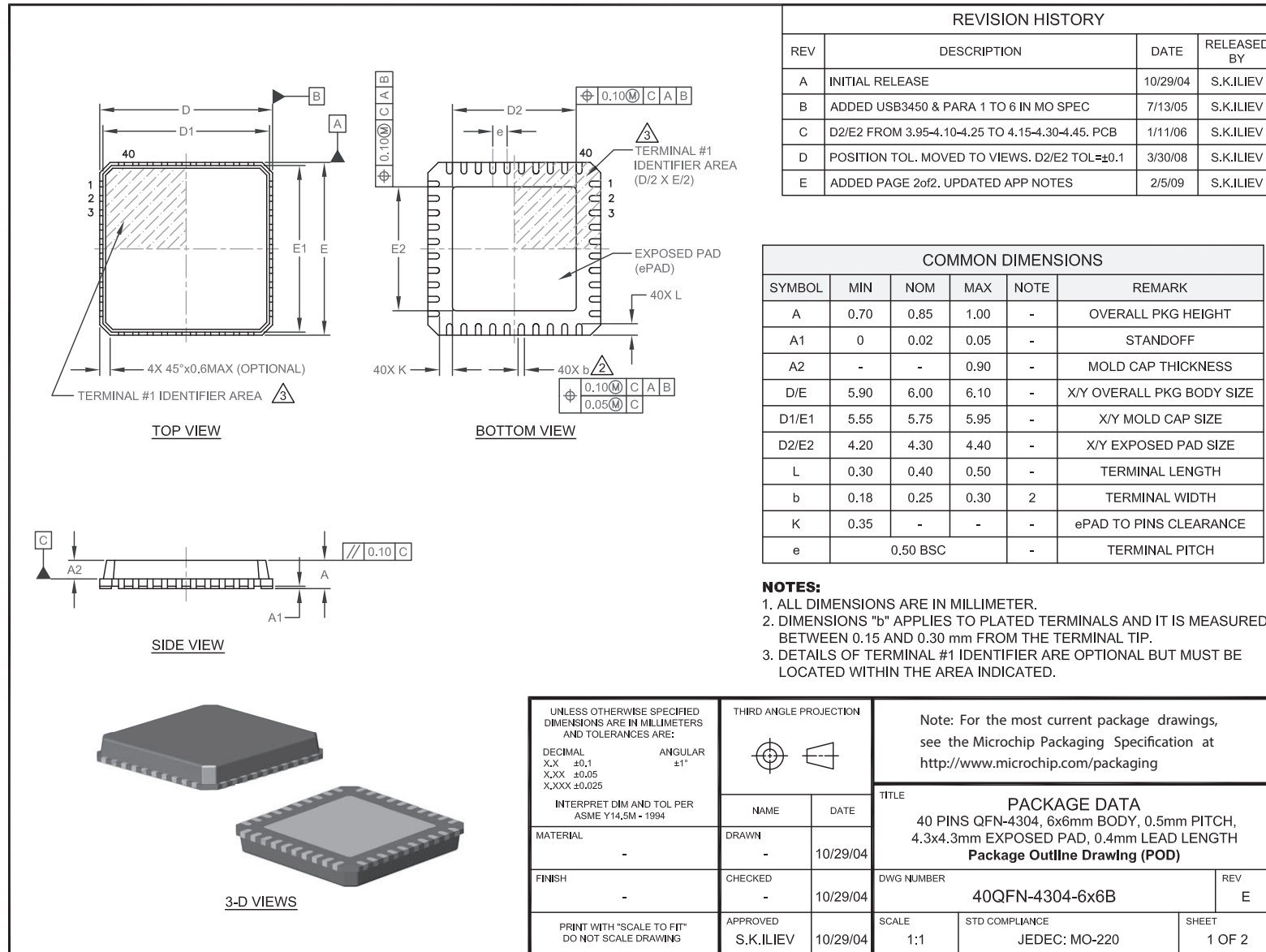

## Legacy SMSC Packaging Outlines and Dimensions

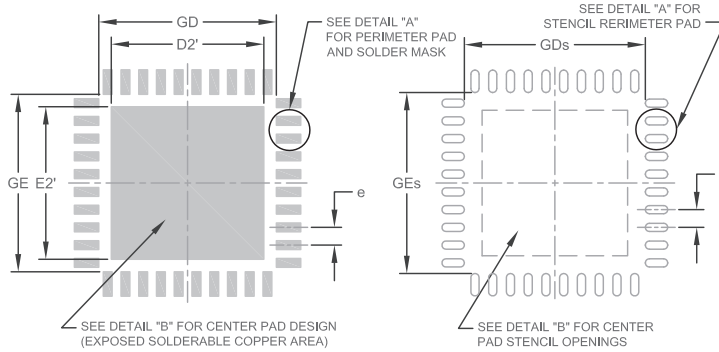

**PCB LAND PATTERN**

**STENCIL**

SEE DETAIL "A" FOR PERIMETER PAD AND SOLDER MASK

SEE DETAIL "A" FOR STENCIL PERIMETER PAD

SEE DETAIL "B" FOR CENTER PAD DESIGN (EXPOSED SOLDERABLE COPPER AREA)

SEE DETAIL "B" FOR CENTER PAD STENCIL OPENINGS

REVISION HISTORY			
REV	DESCRIPTION	DATE	RELEASED BY
E	ADDED PAGE 2of2. UPDATED APP NOTES	2/5/09	S.K.ILIEV

  

LAND PATTERN DIMENSIONS			
SYMBOL	MIN	NOM	MAX
GD/GE	5.00	-	5.10
GDs/GEs	5.05	-	-
D2'/E2'	-	4.30	4.30
Pad: X	-	0.28	0.28
Stencil: Xs	-	0.23	0.25
Pad: Y	-	0.69	0.69
Stencil: Ys	-	0.62	0.64
e	0.50		

**SMT APPLICATION NOTES**

1. THE USER MAY MODIFY THE PCB LAND PATTERN DIMENSIONS BASED ON THEIR EXPERIENCE AND/OR PROCESS CAPABILITY.
2. THE LAND PATTERN CORRESPONDING TO THE PACKAGE EXPOSED PAD (IN THE CENTER) CAN BE LARGER, AND WITH DIFFERENT SHAPE THAN THE EXPOSED PAD ON THE PACKAGE. HOWEVER, THE SOLDERABLE AREA, AS DEFINED BY THE SOLDER MASK (SMD), OR NON-SOLDER MASK DEFINED (NSMD), SHOULD BE AS SHOWN FOR THE BEST THERMAL & ELECTRICAL PERFORMANCE.
3. MAXIMUM THERMAL AND ELECTRICAL PERFORMANCE IS ACHIEVED WHEN AN ARRAY OF SOLID VIAS IS INCORPORATED IN THE CENTER LAND PATTERN (See Options 1 & 2).
4. THE VIAS SHOULD BE AT 0.8 TO 1.2MM PITCH WITH 0.30 TO 0.40MM DIAMETER, AND 1 OZ COPPER VIA BARREL PLATING.
5. NON SOLDER MASK DEFINED (NSMD) PAD DESIGN IS RECOMMENDED FOR PERIMETER LANDS.
6. A LASER-CUT STAINLESS STEEL STENCIL IS RECOMMENDED WITH ELECTRO POLISHED TRAPEZOIDAL WALLS. THE RECOMMENDED STENCIL THICKNESS IS 0.125 mm FOR PITCHES 0.4 and 0.5 mm.
7. RECOMMENDED STENCIL AREA & ASPECT RATIOS ARE 0.66 & 1.5 (MIN) RESPECTIVELY.
8. RECOMMENDED STENCIL APERTURES ARE AS SHOWN.
9. IT IS RECOMMENDED TO USE "NO-CLEAN", TYPE 3 SOLDER PASTE.
10. THE REFLOW PROFILE DEPENDS ON THE EXACT SOLDER PASTE USED AND THE GIVEN BOARD DETAILS, SUCH AS GEOMETRY, COMPONENTS ETC.

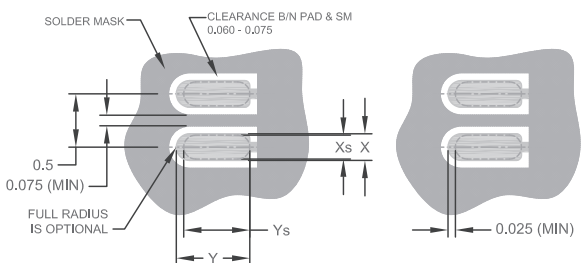

**DETAIL "A"**

**STENCIL OPENING - PERIMETER LANDS**

**OPTION 1**  
(NON-PLUGGED THERMAL VIAS)

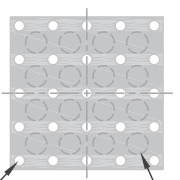

Thermal Vias: Ø0.30mm,  
5x5 Matrix @ 0.95mm Pitch

Stencil Openings: Ø0.60-0.70mm  
4x4 Matrix

**OPTION 3**  
(PLUGGED THERMAL VIAS)

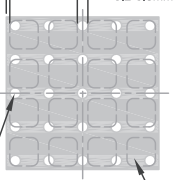

Thermal Vias: Ø0.30mm,  
5x5 Matrix @ 0.95mm Pitch

Stencil Openings: 0.82x0.82mm (MAX)  
4x4 Matrix

**DETAIL "B"**

**THERMAL VIAS and STENCIL OPENING - CENTER PAD**

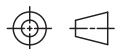
<p>UNLESS OTHERWISE SPECIFIED DIMENSIONS ARE IN MILLIMETERS AND TOLERANCES ARE:</p> <table style="width: 100%;"> <tr> <td>DECIMAL</td> <td>ANGULAR</td> </tr> <tr> <td>X.X ±0.1</td> <td>±1°</td> </tr> <tr> <td>X.XX ±0.05</td> <td></td> </tr> <tr> <td>X.XXX ±0.025</td> <td></td> </tr> </table> <p>INTERPRET DIM AND TOL PER ASME Y14.5M - 1994</p>	DECIMAL	ANGULAR	X.X ±0.1	±1°	X.XX ±0.05		X.XXX ±0.025		<p>THIRD ANGLE PROJECTION</p> 	<p>Note: For the most current package drawings, see the Microchip Packaging Specification at <a href="http://www.microchip.com/packageing">http://www.microchip.com/packageing</a></p>																																													
DECIMAL	ANGULAR																																																						
X.X ±0.1	±1°																																																						
X.XX ±0.05																																																							
X.XXX ±0.025																																																							
<table border="1" style="width: 100%; border-collapse: collapse;"> <tr> <td>MATERIAL</td> <td>DRAWN</td> <td>DATE</td> </tr> <tr> <td>-</td> <td>-</td> <td>2/5/09</td> </tr> <tr> <td>FINISH</td> <td>CHECKED</td> <td>DATE</td> </tr> <tr> <td>-</td> <td>-</td> <td>2/5/09</td> </tr> <tr> <td>PRINT WITH "SCALE TO FIT" DO NOT SCALE DRAWING</td> <td>APPROVED</td> <td>DATE</td> </tr> <tr> <td></td> <td>S.K.ILIEV</td> <td>2/5/09</td> </tr> </table>	MATERIAL	DRAWN	DATE	-	-	2/5/09	FINISH	CHECKED	DATE	-	-	2/5/09	PRINT WITH "SCALE TO FIT" DO NOT SCALE DRAWING	APPROVED	DATE		S.K.ILIEV	2/5/09	<table border="1" style="width: 100%; border-collapse: collapse;"> <tr> <td colspan="2">NAME</td> <td>DATE</td> </tr> <tr> <td colspan="2">-</td> <td>2/5/09</td> </tr> <tr> <td colspan="2">CHECKED</td> <td>DATE</td> </tr> <tr> <td colspan="2">-</td> <td>2/5/09</td> </tr> <tr> <td colspan="2">APPROVED</td> <td>DATE</td> </tr> <tr> <td colspan="2">S.K.ILIEV</td> <td>2/5/09</td> </tr> </table>	NAME		DATE	-		2/5/09	CHECKED		DATE	-		2/5/09	APPROVED		DATE	S.K.ILIEV		2/5/09	<table border="1" style="width: 100%; border-collapse: collapse;"> <tr> <td colspan="2">TITLE</td> <td rowspan="2">REV</td> </tr> <tr> <td colspan="2" style="text-align: center;"> <b>PACKAGE DATA</b>            40 PINS QFN-4304, 6x6mm BODY, 0.5mm PITCH,            4,3x4,3mm EXPOSED PAD, 0,4mm LEAD LENGTH  <b>Application Notes</b> </td> </tr> <tr> <td colspan="2">DWG NUMBER</td> <td>REV</td> </tr> <tr> <td colspan="2" style="text-align: center;">40QFN-4304-6x6B</td> <td style="text-align: center;">E</td> </tr> <tr> <td>SCALE</td> <td>STD COMPLIANCE</td> <td>SHEET</td> </tr> <tr> <td style="text-align: center;">1:1</td> <td style="text-align: center;">JEDEC: MO-220</td> <td style="text-align: center;">2 OF 2</td> </tr> </table>	TITLE		REV	<b>PACKAGE DATA</b> 40 PINS QFN-4304, 6x6mm BODY, 0.5mm PITCH, 4,3x4,3mm EXPOSED PAD, 0,4mm LEAD LENGTH <b>Application Notes</b>		DWG NUMBER		REV	40QFN-4304-6x6B		E	SCALE	STD COMPLIANCE	SHEET	1:1	JEDEC: MO-220	2 OF 2
MATERIAL	DRAWN	DATE																																																					
-	-	2/5/09																																																					
FINISH	CHECKED	DATE																																																					
-	-	2/5/09																																																					
PRINT WITH "SCALE TO FIT" DO NOT SCALE DRAWING	APPROVED	DATE																																																					
	S.K.ILIEV	2/5/09																																																					
NAME		DATE																																																					
-		2/5/09																																																					
CHECKED		DATE																																																					
-		2/5/09																																																					
APPROVED		DATE																																																					
S.K.ILIEV		2/5/09																																																					
TITLE		REV																																																					
<b>PACKAGE DATA</b> 40 PINS QFN-4304, 6x6mm BODY, 0.5mm PITCH, 4,3x4,3mm EXPOSED PAD, 0,4mm LEAD LENGTH <b>Application Notes</b>																																																							
DWG NUMBER		REV																																																					
40QFN-4304-6x6B		E																																																					
SCALE	STD COMPLIANCE	SHEET																																																					
1:1	JEDEC: MO-220	2 OF 2																																																					

## Legacy SMSC Packaging Outlines and Dimensions

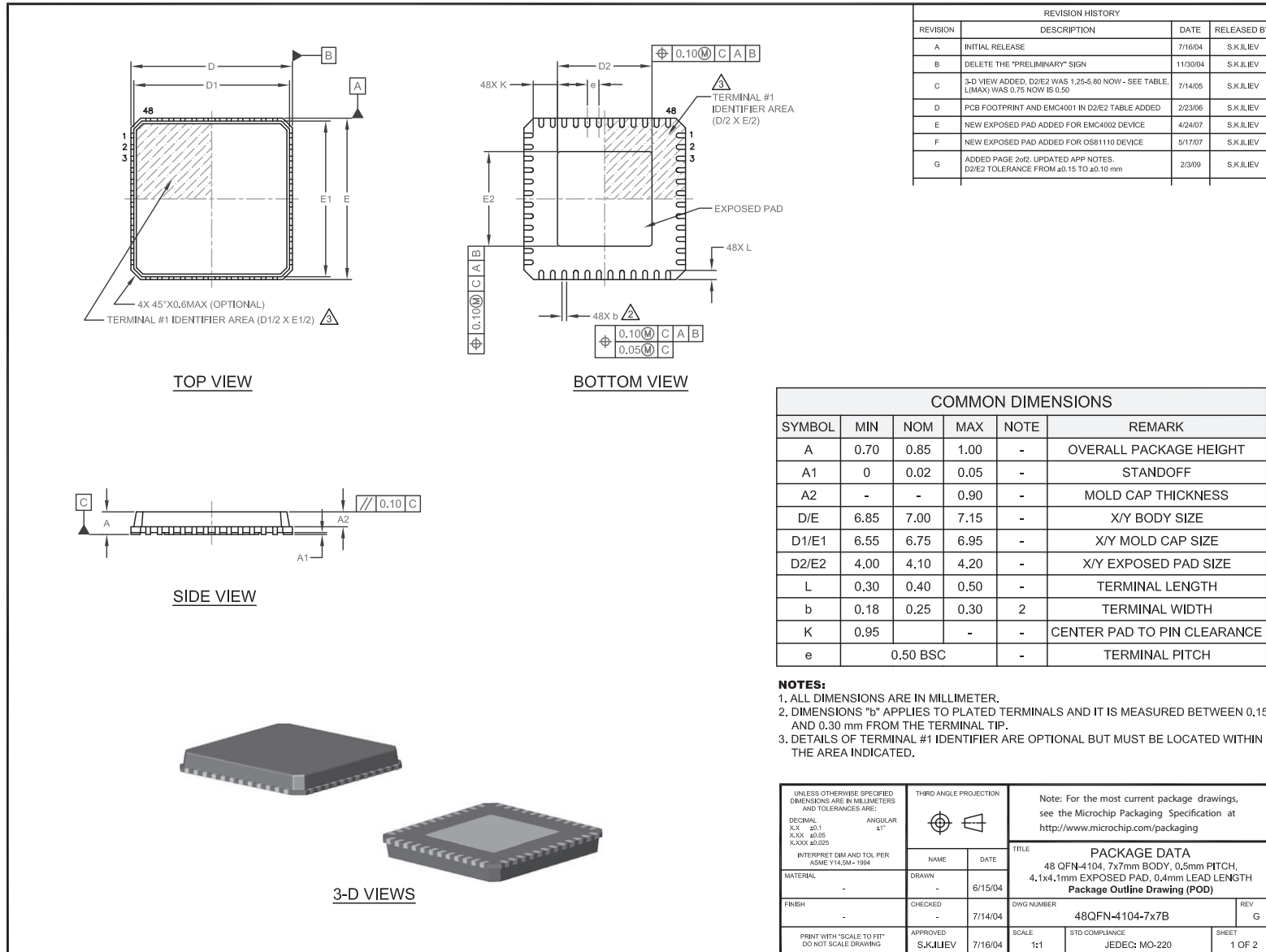

## Legacy SMSC Packaging Outlines and Dimensions

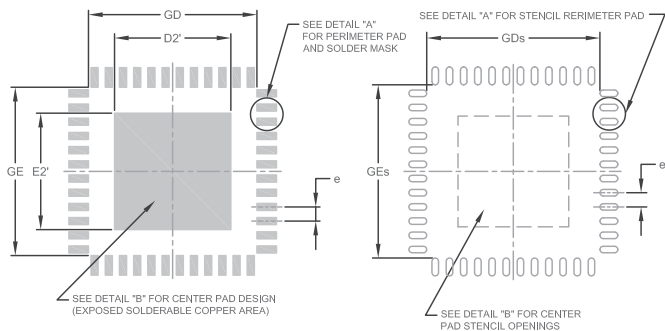

**PCB LAND PATTERN**

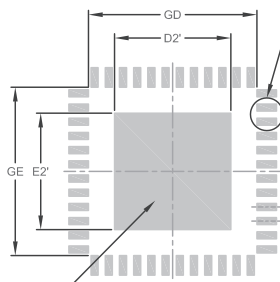

**STENCIL**

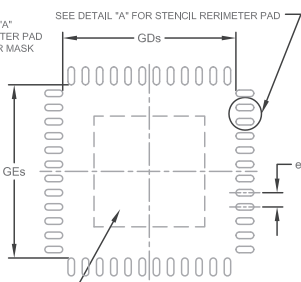

REVISION HISTORY			
REV	DESCRIPTION	DATE	RELEASED BY
G	ADDED PAGE 2 of 2, UPDATED APP NOTES AND D2/E2 TOLERANCE FROM ±0.15 TO ±0.10 mm	2/3/09	S.K.ILIEV

  

LAND PATTERN DIMENSIONS			
SYMBOL	MIN	NOM	MAX
GD/GE	6.00	-	6.10
GDs/GEs	6.05	-	-
D2'/E2'	-	4.10	-
Pad: X	-	0.28	0.28
Stencil: Xs	-	0.23	0.25
Pad: Y	-	0.69	0.69
Stencil: Ys	-	0.62	0.64
e	0.50		

**SMT APPLICATION NOTES**

- THE USER MAY MODIFY THE PCB LAND PATTERN DIMENSIONS BASED ON THEIR EXPERIENCE AND/OR PROCESS CAPABILITY.
- THE LAND PATTERN CORRESPONDING TO THE PACKAGE EXPOSED PAD (IN THE CENTER) CAN BE LARGER, AND WITH DIFFERENT SHAPE THAN THE EXPOSED PAD ON THE PACKAGE. HOWEVER, THE SOLDERABLE AREA, AS DEFINED BY THE SOLDER MASK (SMD), OR NON-SOLDER MASK DEFINED (NSMD), SHOULD BE AS SHOWN FOR THE BEST THERMAL & ELECTRICAL PERFORMANCE.
- MAXIMUM THERMAL AND ELECTRICAL PERFORMANCE IS ACHIEVED WHEN AN ARRAY OF SOLID VIAS IS INCORPORATED IN THE CENTER LAND PATTERN. (See Options 1 & 2)
- THE VIAS SHOULD BE AT 0.8 to 1.2MM PITCH WITH 0.30 to 0.40MM DIAMETER, AND 1 OZ COPPER VIA BARREL PLATING.
- NON SOLDER MASK DEFINED (NSMD) PAD DESIGN IS RECOMMENDED FOR PERIMETER LANDS.
- A LASER-CUT STAINLESS STEEL STENCIL IS RECOMMENDED WITH ELECTRO POLISHED TRAPEZOIDAL WALLS. THE RECOMMENDED STENCIL THICKNESS IS 0.125 mm FOR PITCHES 0.4 and 0.5 mm.
- RECOMMENDED STENCIL AREA & ASPECT RATIOS ARE 0.66 & 1.5 (MIN) RESPECTIVELY.
- RECOMMENDED STENCIL APERTURES ARE AS SHOWN.
- IT IS RECOMMENDED TO USE "NO-CLEAN", TYPE 3 SOLDER PASTE.
- THE REFLOW PROFILE DEPENDS ON THE EXACT SOLDER PASTE USED AND THE GIVEN BOARD DETAILS, SUCH AS GEOMETRY, COMPONENTS ETC.

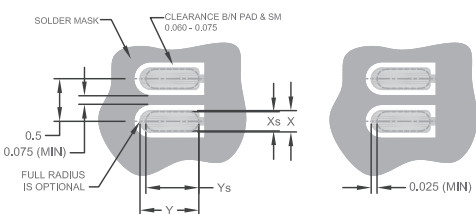

**DETAIL "A"**  
**STENCIL OPENING - PERIMETER LANDS**

**OPTION 1**  
(NON-PLUGGED THERMAL VIAS)

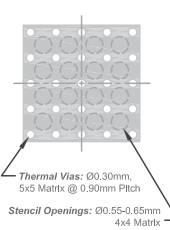

**OPTION 3**  
(PLUGGED THERMAL VIAS)

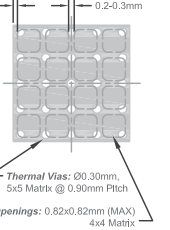

**DETAIL "B"**  
**THERMAL VIAS and STENCIL OPENING - CENTER PAD**

UNLESS OTHERWISE SPECIFIED DIMENSIONS ARE IN MILLIMETERS AND TOLERANCES ARE: DECIMAL                    ANGULAR XX     ±0.1                    ±1° X.X    ±0.05 X.XXX ±0.025	THIRD ANGLE PROJECTION 	Note: For the most current package drawings, see the Microchip Packaging Specification at <a href="http://www.microchip.com/packaging">http://www.microchip.com/packaging</a>
INTERPRET DIM AND TOL PER ASME Y14.5M - 1994	NAME                    DATE	TITLE <b>PACKAGE DATA</b> 48 QFN-4104, 7x7mm BODY, 0.5mm PITCH, 4.1x4.1mm EXPOSED PAD, 0.4mm LEAD LENGTH <b>Application Notes</b>
MATERIAL                    DRAWN                    DATE	FINISH                    CHECKED                    DATE	DWG #                    REV
PRINT WITH "SCALE TO FIT" DO NOT SCALE DRAWING	APPROVED S.K.ILIEV                    2/3/09	SCALE                    STD COMPLIANCE                    SHEET
	1:1                    -                    2 OF 2	48QFN-4104-7x7B                    G

## Legacy SMSC Packaging Outlines and Dimensions

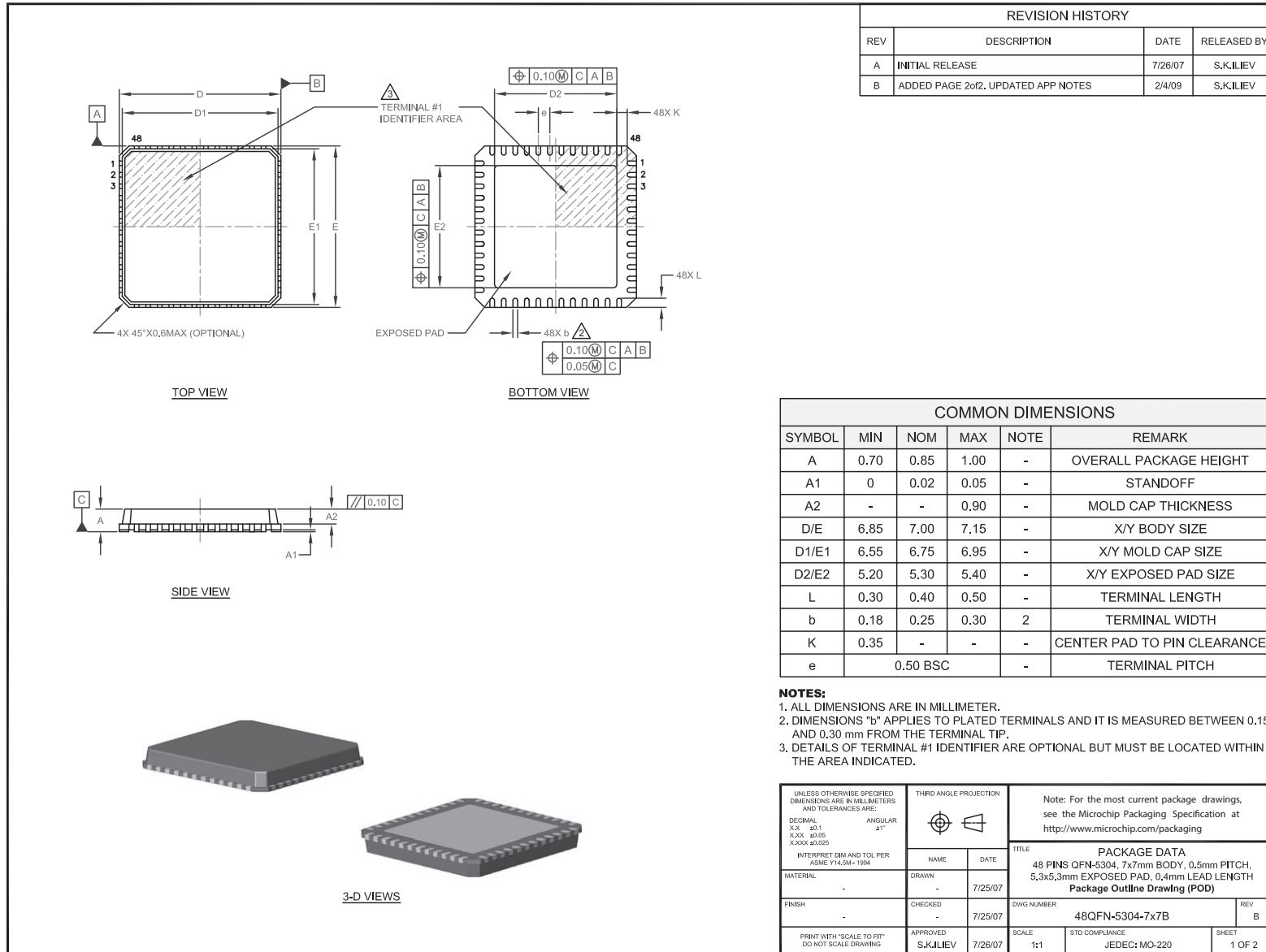



## Legacy SMSC Packaging Outlines and Dimensions

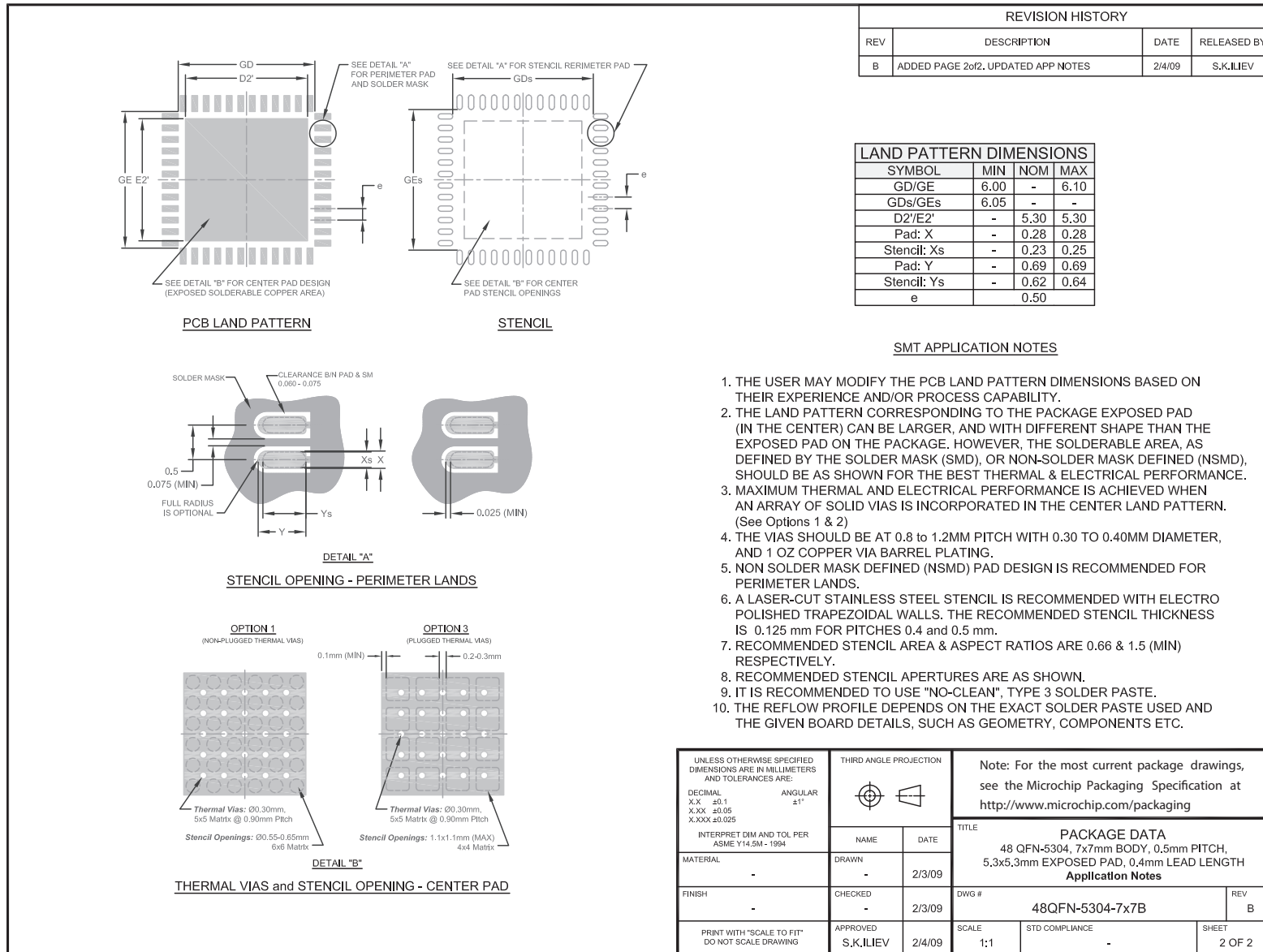

## Legacy SMSC Packaging Outlines and Dimensions

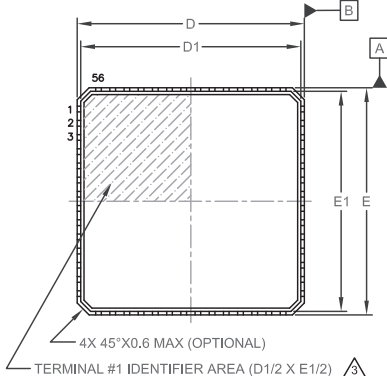

**TOP VIEW**

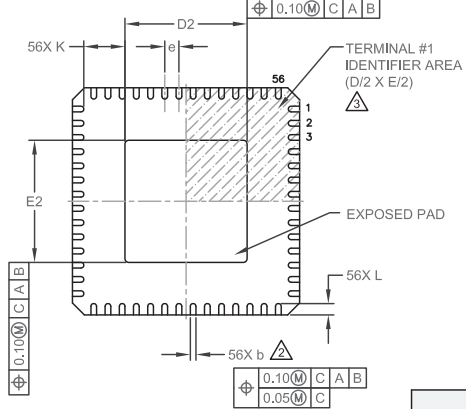

**BOTTOM VIEW**

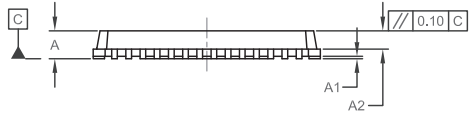

**SIDE VIEW**

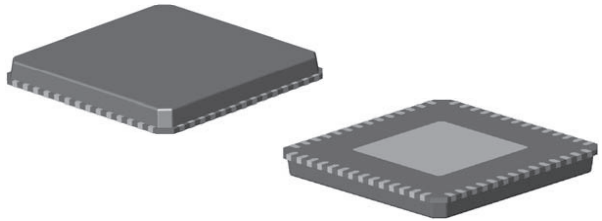

**3-D VIEWS**

**REVISION HISTORY**

REV	DESCRIPTION	DATE	RELEASED BY
A	INITIAL RELEASE	2/7/04	S.K.ILIEV
B	REMOVE "PRELIMINARY" NOTE	10/7/04	S.K.ILIEV
C	L(MAX) FROM 0.55 TO 0.50, ADD D2/E2 VAR TABLE	7/2/05	S.K.ILIEV
D	DELETE EMC2700, ADD USB2504A, USB2524 AND EMC2700P IN THE D2/E2 VARIATIONS TABLE	4/13/06	S.K.ILIEV
E	4304 GEOMETRY SHOWN ONLY. ADDED PAGE 2of2	6/11/08	S.K.ILIEV

**COMMON DIMENSIONS**

SYMBOL	MIN	NOM	MAX	NOTE	REMARK
A	0.70	0.85	1.00	-	OVERALL PACKAGE HEIGHT
A1	0	0.02	0.05	-	STANDOFF
A2	-	-	0.90	-	MOLD CAP THICKNESS
D/E	7.85	8.00	8.15	-	X/Y BODY SIZE
D1/E1	7.55	-	7.95	-	X/Y MOLD CAP SIZE
D2/E2	4.20	4.30	4.40	-	X/Y EXPOSED PAD SIZE
L	0.30	0.40	0.50	-	TERMINAL LENGTH
b	0.18	0.25	0.30	2	TERMINAL WIDTH
K	1.35	-	-	-	CENTER PAD TO PIN CLEARANCE
e	0.50 BSC			-	TERMINAL PITCH

**NOTES:**

- ALL DIMENSIONS ARE IN MILLIMETER.
- DIMENSIONS "b" APPLIES TO PLATED TERMINALS AND IT IS MEASURED BETWEEN 0.15 AND 0.30 mm FROM THE TERMINAL TIP.
- DETAILS OF TERMINAL #1 IDENTIFIER ARE OPTIONAL BUT MUST BE LOCATED WITHIN THE AREA INDICATED.

UNLESS OTHERWISE SPECIFIED DIMENSIONS ARE IN MILLIMETERS AND TOLERANCES ARE:

DECIMAL      ANGULAR  
 XX ±0.1      ±1°  
 X.XX ±0.05  
 X.XXX ±0.025

INTERPRET DIM AND TOL PER ASME Y14.5M - 1994

MATERIAL	-	DRAWN	-	DATE	2/06/04
FINISH	-	CHECKED	-	DATE	2/07/04
APPROVED	S.K.ILIEV	DATE	2/07/04		

PRINT WITH "SCALE TO FIT" DO NOT SCALE DRAWING

THIRD ANGLE PROJECTION



Note: For the most current package drawings, see the Microchip Packaging Specification at <http://www.microchip.com/packaging>

<b>TITLE</b>	
<b>PACKAGE DATA</b> 56 QFN-4304, 8x8mm BODY, 0.5mm PITCH, 4.3x4.3mm ePAD, 0.4mm LEAD LENGTH <b>Package Outline Drawing (POD)</b>	
DWG #	56QFN-4304-8x8B
SCALE	1:1
STD COMPLIANCE	JEDEC: MO-220
SHEET	1 OF 2

## Legacy SMSC Packaging Outlines and Dimensions

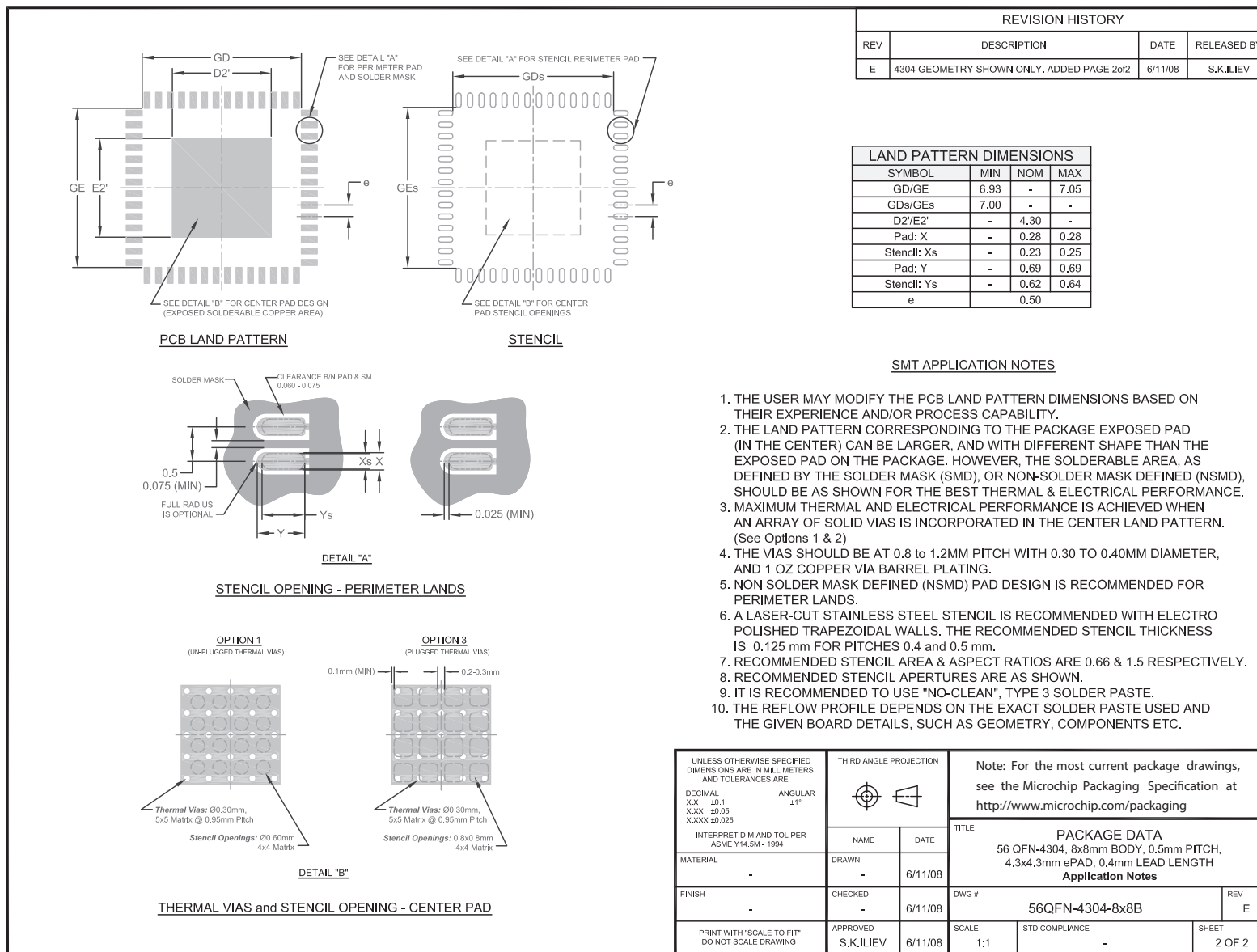

**Legacy SMSC Packaging Outlines and Dimensions**

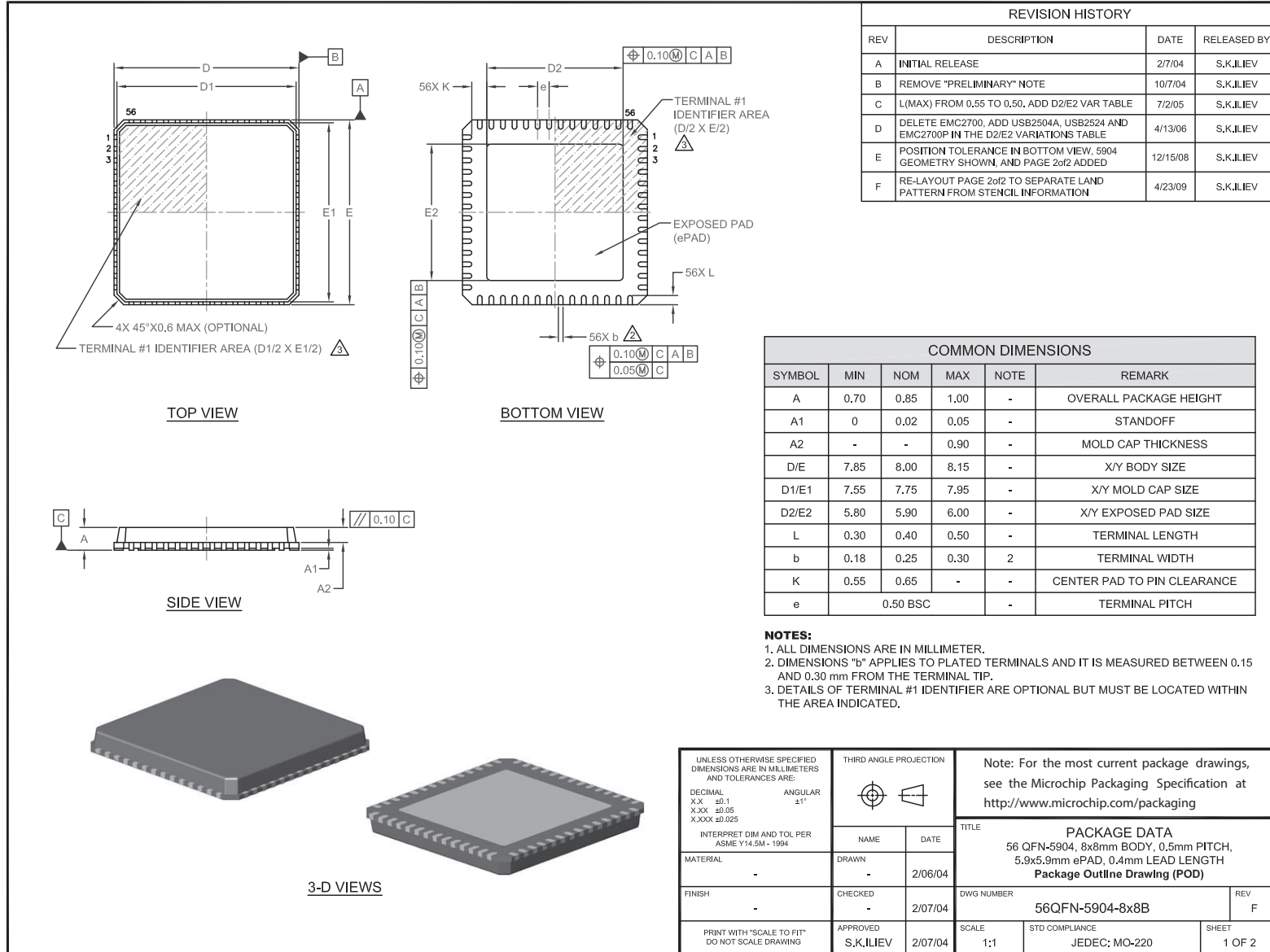

## Legacy SMSC Packaging Outlines and Dimensions

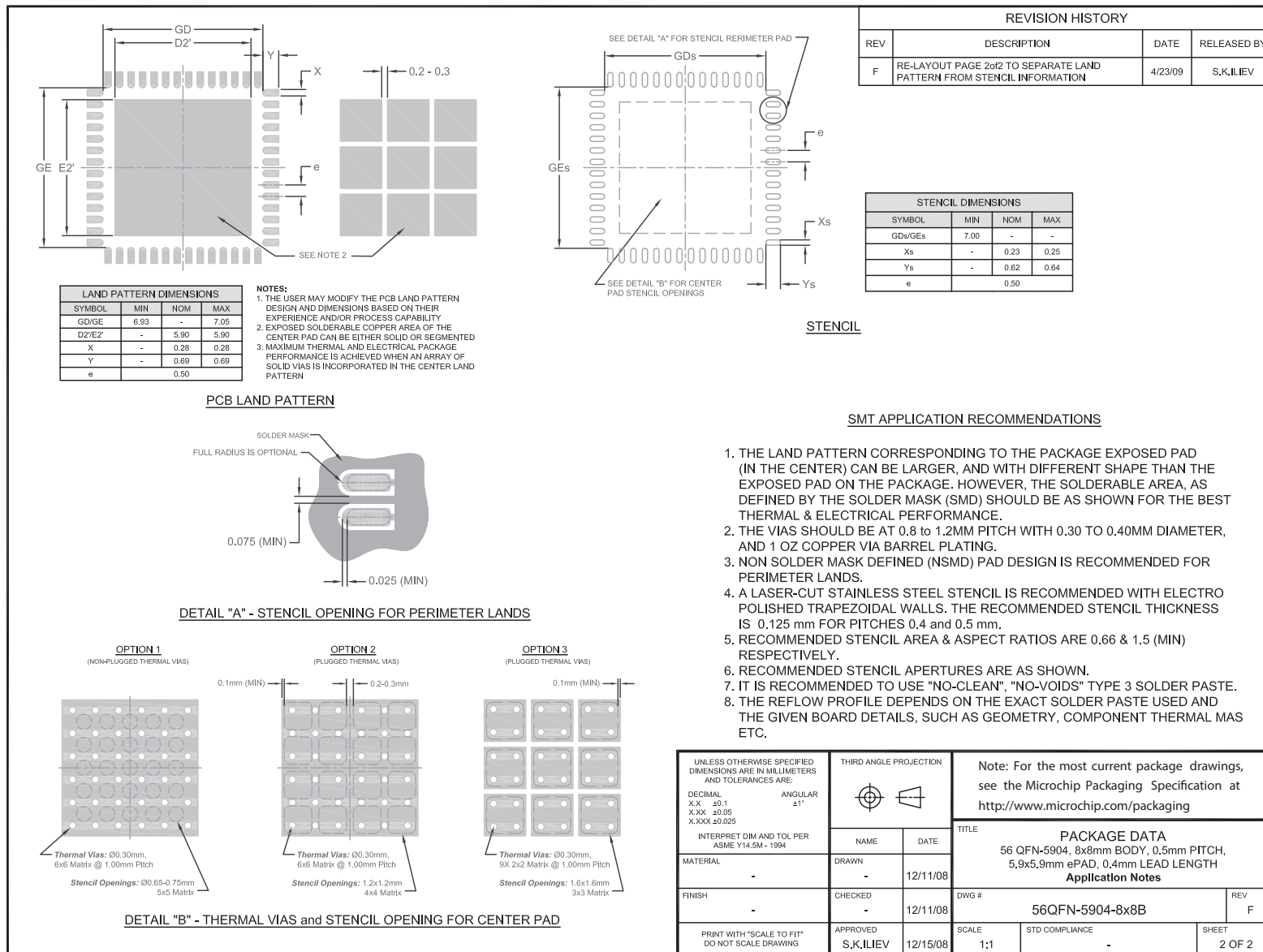

## Legacy SMSC Packaging Outlines and Dimensions

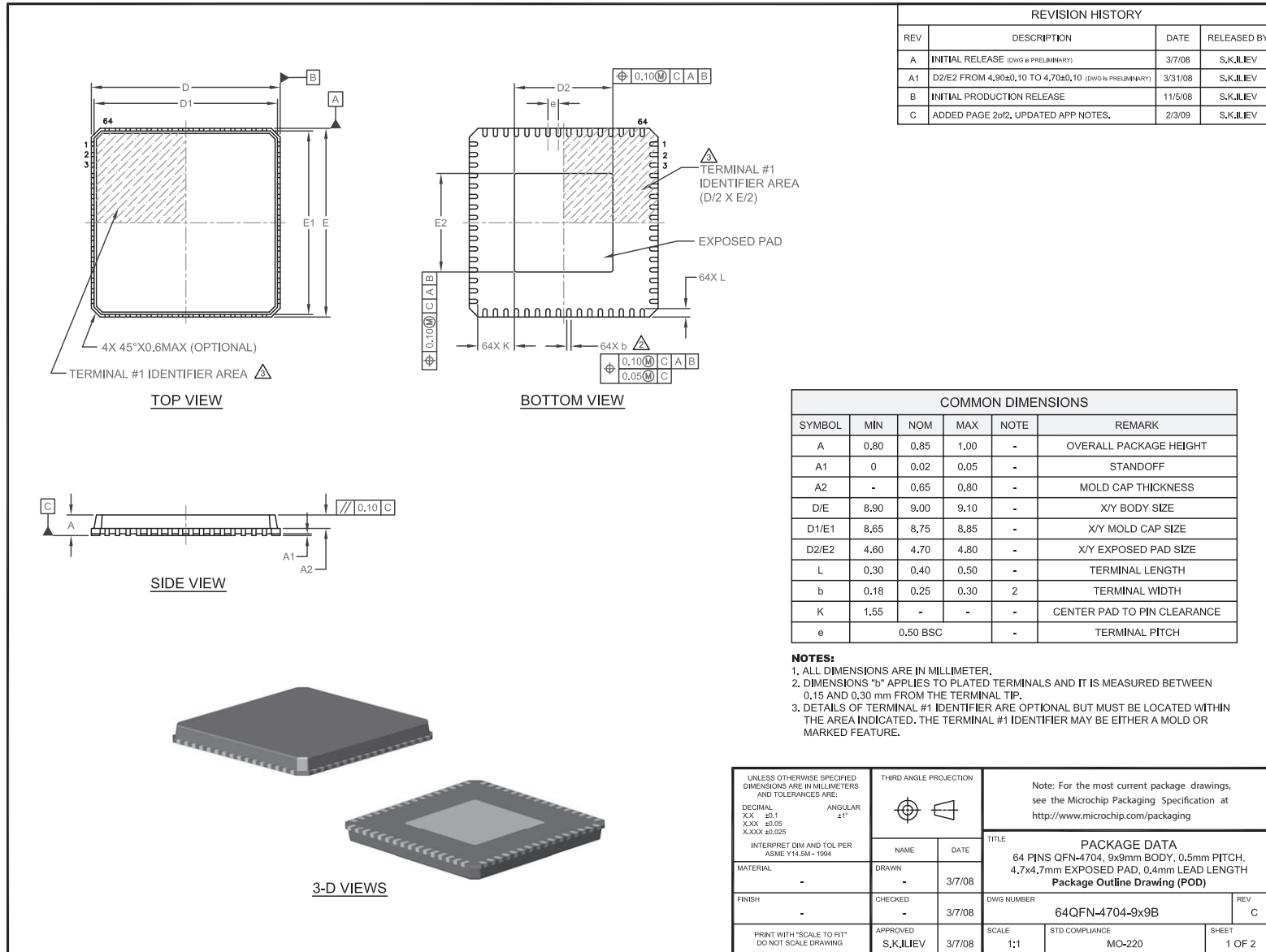

## Legacy SMSC Packaging Outlines and Dimensions

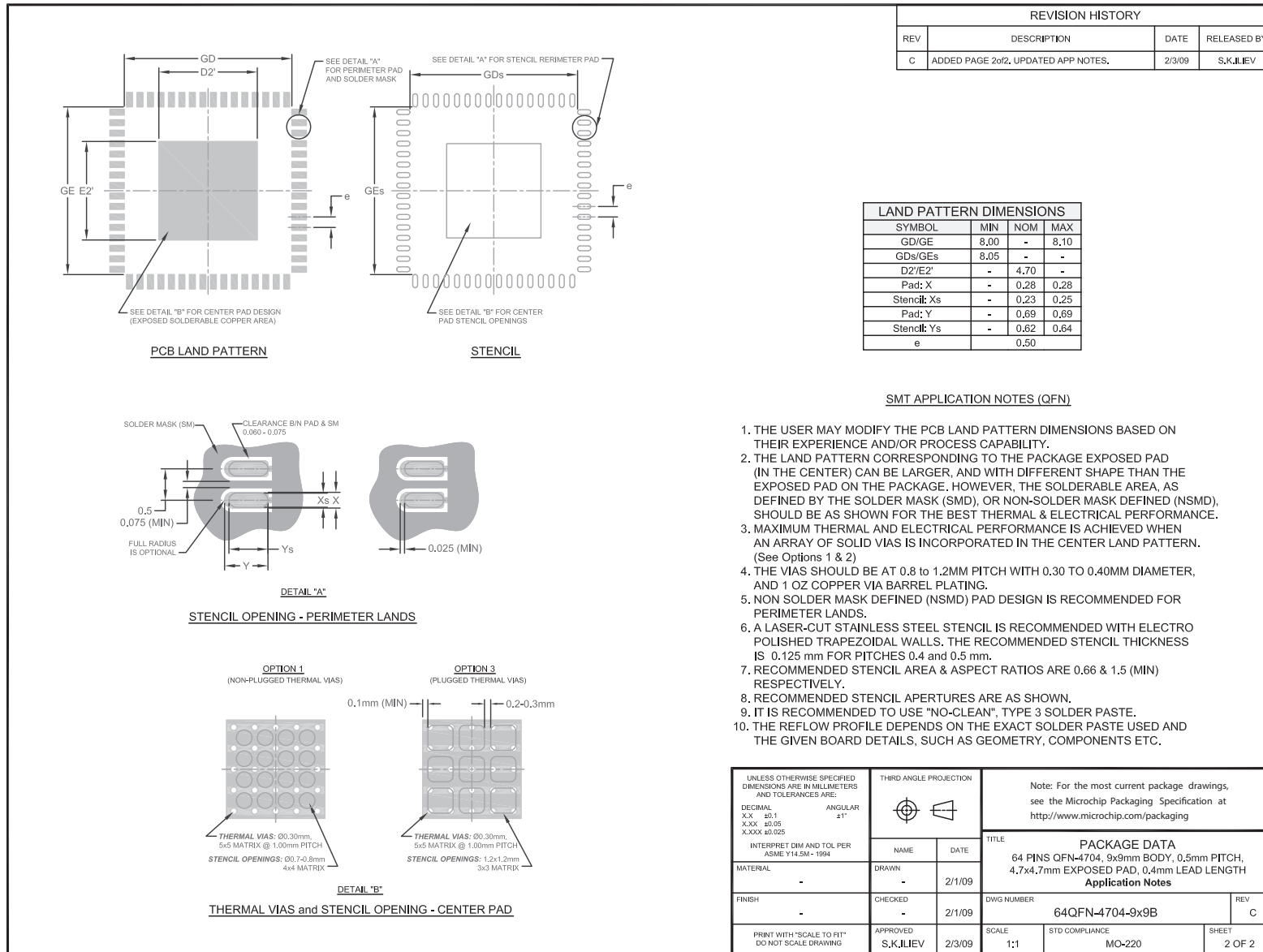

NAME	DATE
DRAWN	2/1/09
CHECKED	2/1/09
APPROVED	2/3/09

PRINT WITH "SCALE TO FIT" DO NOT SCALE DRAWING

## Legacy SMSC Packaging Outlines and Dimensions

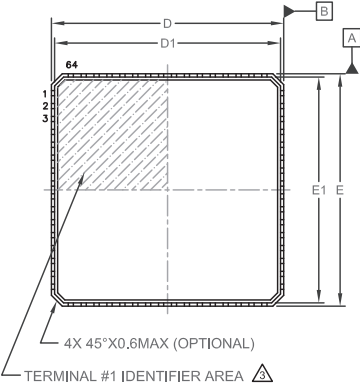

**TOP VIEW**

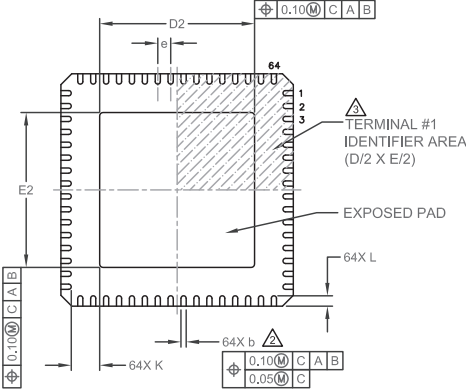

**BOTTOM VIEW**

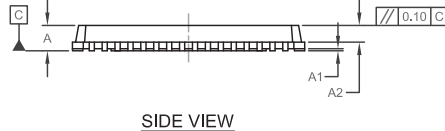

**SIDE VIEW**

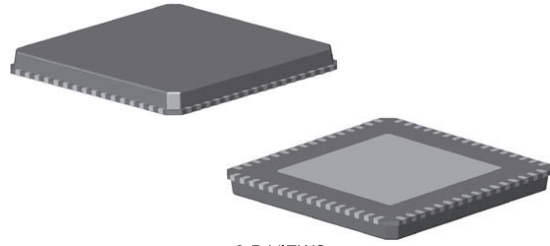

**3-D VIEWS**

REVISION HISTORY

REV	DESCRIPTION	DATE	RELEASED BY
A	INITIAL RELEASE	1/21/09	S.K.IJLIEV
B	ADDED PAGE 2-of-2, UPDATED APP NOTES.	2/3/09	S.K.IJLIEV

  

COMMON DIMENSIONS					
SYMBOL	MIN	NOM	MAX	NOTE	REMARK
A	0.80	0.85	1.00	-	OVERALL PACKAGE HEIGHT
A1	0	0.02	0.05	-	STANDOFF
A2	-	0.65	0.80	-	MOLD CAP THICKNESS
D/E	8.90	9.00	9.10	-	X/Y BODY SIZE
D1/E1	8.65	8.75	8.85	-	X/Y MOLD CAP SIZE
D2/E2	5.90	6.00	6.10	-	X/Y EXPOSED PAD SIZE
L	0.30	0.40	0.50	-	TERMINAL LENGTH
b	0.18	0.25	0.30	2	TERMINAL WIDTH
K	0.90	-	-	-	CENTER PAD TO PIN CLEARANCE
e	0.50 BSC		-	-	TERMINAL PITCH

**NOTES:**

- ALL DIMENSIONS ARE IN MILLIMETER.
- DIMENSIONS "b" APPLIES TO PLATED TERMINALS AND IT IS MEASURED BETWEEN 0.15 AND 0.30 mm FROM THE TERMINAL TIP.
- DETAILS OF TERMINAL #1 IDENTIFIER ARE OPTIONAL BUT MUST BE LOCATED WITHIN THE AREA INDICATED. THE TERMINAL #1 IDENTIFIER MAY BE EITHER A MOLD OR MARKED FEATURE.

<small>UNLESS OTHERWISE SPECIFIED DIMENSIONS ARE IN MILLIMETERS AND TOLERANCES ARE:</small> DECIMAL                      ANGULAR X.X                      ±0.1 X.XX                      ±0.05 X.XXX                      ±0.025 <small>INTERPRET DIM AND TOL PER ASME Y14.5M-1994</small>	<small>THIRD ANGLE PROJECTION</small> 	<small>Note: For the most current package drawings, see the Microchip Packaging Specification at <a href="http://www.microchip.com/package">http://www.microchip.com/package</a></small>  <b>TITLE</b> <b>PACKAGE DATA</b> 64 PINS QFN-6004, 8x8mm BODY, 0.5mm PITCH, 6.0x6.0mm EXPOSED PAD, 0.4mm LEAD LENGTH <b>Package Outline Drawing (POD)</b>																									
<table border="1" style="width: 100%; border-collapse: collapse;"> <tr> <td style="width: 30%;">MATERIAL</td> <td style="width: 30%;">DRAWN</td> <td style="width: 30%;">DATE</td> </tr> <tr> <td style="text-align: center;">-</td> <td style="text-align: center;">-</td> <td style="text-align: center;">12/19/08</td> </tr> <tr> <td style="vertical-align: top;">FINISH</td> <td style="vertical-align: top;">CHECKED</td> <td style="vertical-align: top;">DATE</td> </tr> <tr> <td style="text-align: center;">-</td> <td style="text-align: center;">-</td> <td style="text-align: center;">1/20/09</td> </tr> <tr> <td style="vertical-align: top;">APPROVED</td> <td style="vertical-align: top;">SCALE</td> <td style="vertical-align: top;">STD COMPLIANCE</td> </tr> <tr> <td style="text-align: center;">S.K.IJLIEV</td> <td style="text-align: center;">1:1</td> <td style="text-align: center;">MO-220</td> </tr> </table>	MATERIAL	DRAWN	DATE	-	-	12/19/08	FINISH	CHECKED	DATE	-	-	1/20/09	APPROVED	SCALE	STD COMPLIANCE	S.K.IJLIEV	1:1	MO-220	<table border="1" style="width: 100%; border-collapse: collapse;"> <tr> <td style="width: 60%;">DWG NUMBER</td> <td style="width: 20%;">REV</td> </tr> <tr> <td style="text-align: center;">64QFN-6004-9x9B</td> <td style="text-align: center;">B</td> </tr> <tr> <td colspan="2" style="text-align: center;">SHEET</td> </tr> <tr> <td colspan="2" style="text-align: center;">1 OF 2</td> </tr> </table>	DWG NUMBER	REV	64QFN-6004-9x9B	B	SHEET		1 OF 2	
MATERIAL	DRAWN	DATE																									
-	-	12/19/08																									
FINISH	CHECKED	DATE																									
-	-	1/20/09																									
APPROVED	SCALE	STD COMPLIANCE																									
S.K.IJLIEV	1:1	MO-220																									
DWG NUMBER	REV																										
64QFN-6004-9x9B	B																										
SHEET																											
1 OF 2																											



## Legacy SMSC Packaging Outlines and Dimensions

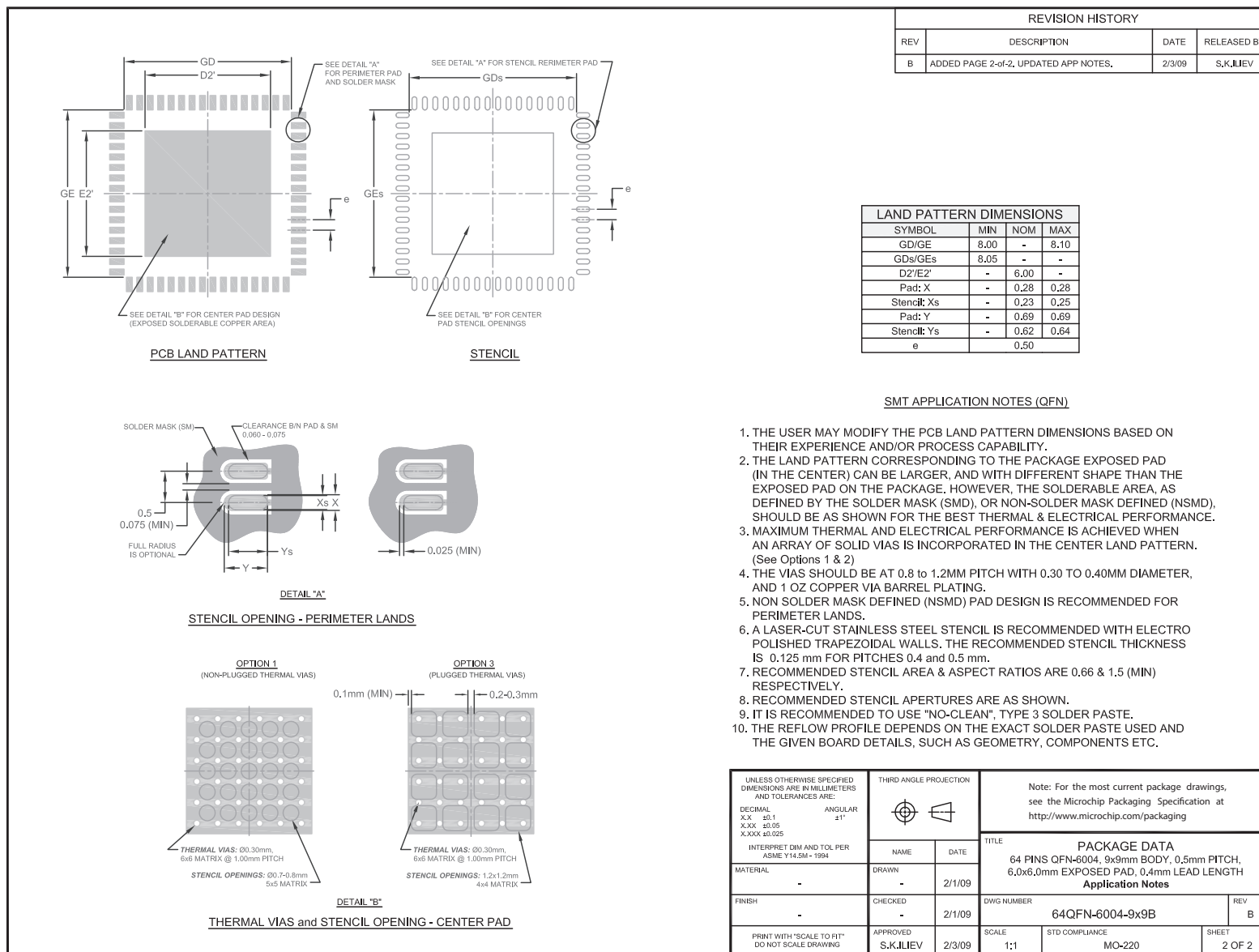

## Legacy SMSC Packaging Outlines and Dimensions

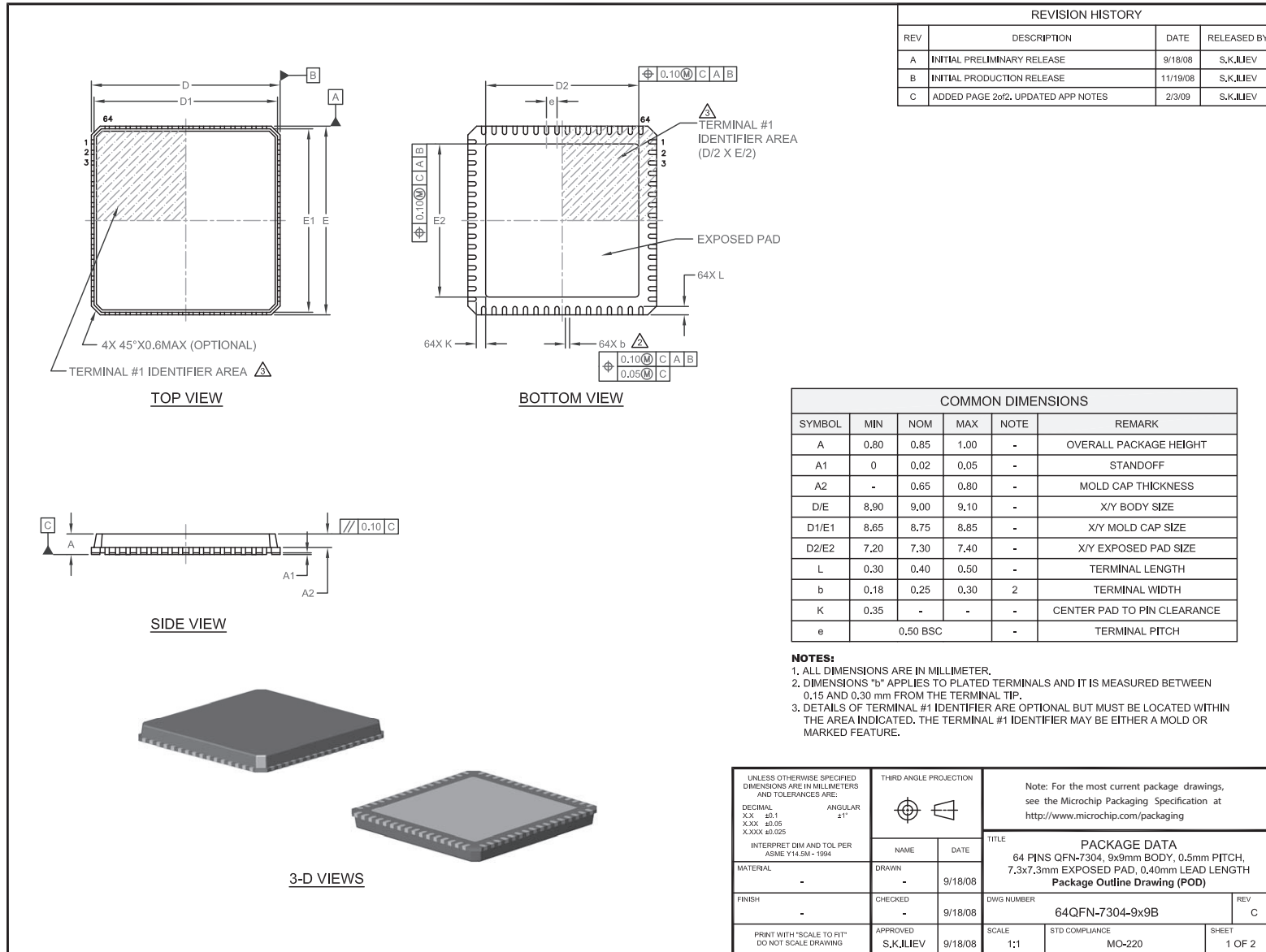

## Legacy SMSC Packaging Outlines and Dimensions

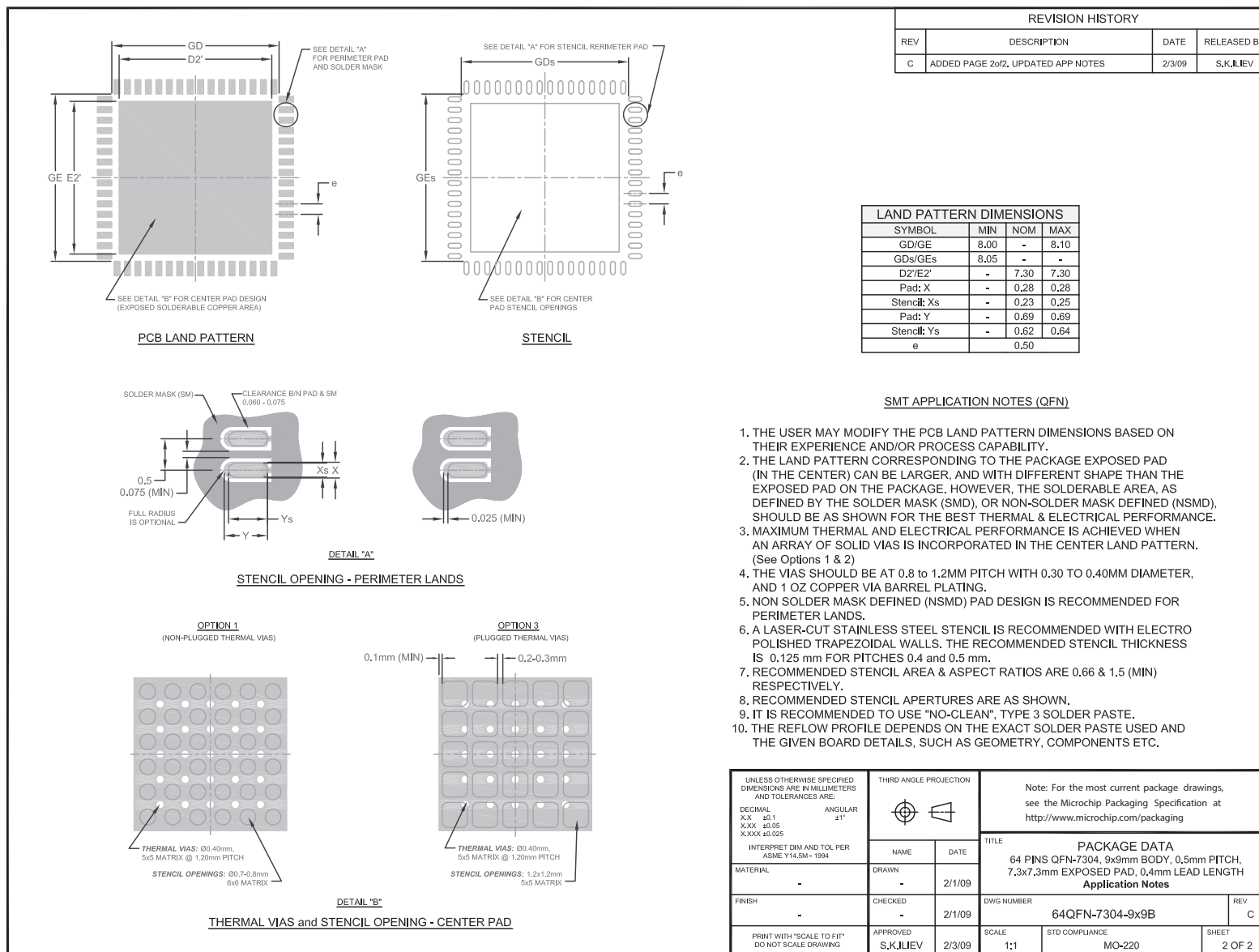

## Legacy SMSC Packaging Outlines and Dimensions

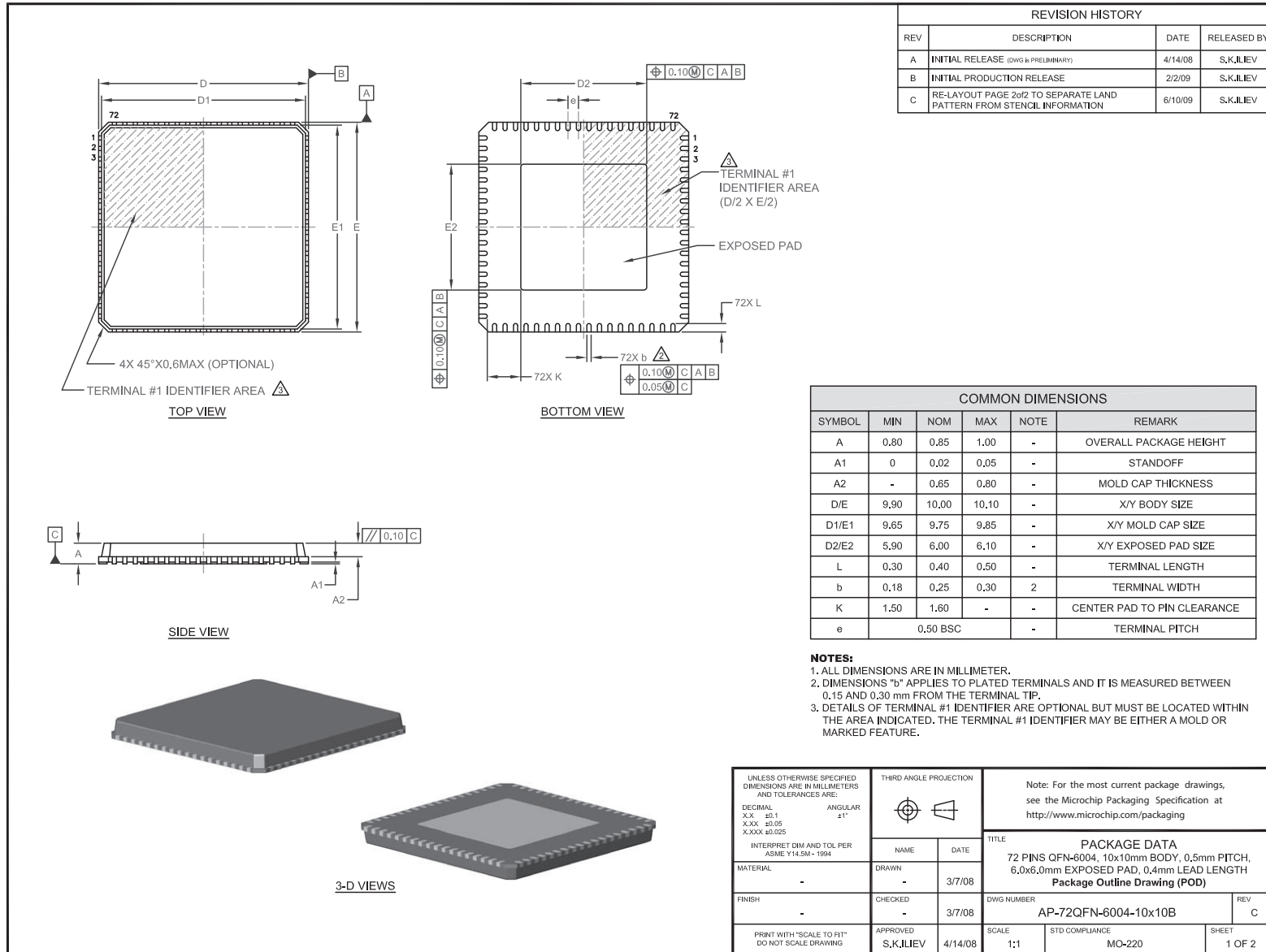

## Legacy SMSC Packaging Outlines and Dimensions

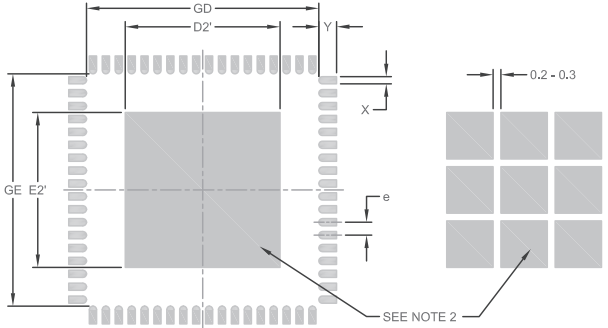

**PCB LAND PATTERN**

LAND PATTERN DIMENSIONS			
SYMBOL	MIN	NOM	MAX
GD/GE	9.00	-	9.10
D2'/E2'	-	6.00	-
X	-	0.28	0.28
Y	-	0.69	-
e	-	0.50	-

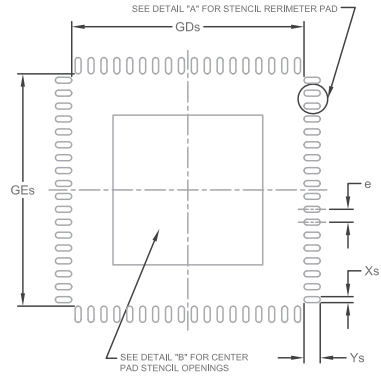

**STENCIL**

STENCIL DIMENSIONS			
SYMBOL	MIN	NOM	MAX
GDs/GEs	9.05	-	-
Xs	-	0.23	0.25
Ys	-	0.62	0.64
e	-	0.50	-

REVISION HISTORY			
REV	DESCRIPTION	DATE	RELEASED BY
C	RE-LAYOUT PAGE 2of2 TO SEPARATE LAND PATTERN FROM STENCIL INFORMATION	6/10/09	S.K.JLIEV

**NOTES:**

1. THE USER MAY MODIFY THE PCB LAND PATTERN DESIGN AND DIMENSIONS BASED ON THEIR EXPERIENCE AND/OR PROCESS CAPABILITY.
2. EXPOSED SOLDERABLE COPPER AREA OF THE CENTER PAD CAN BE EITHER SOLID OR SEGMENTED.
3. MAXIMUM THERMAL AND ELECTRICAL PACKAGE PERFORMANCE IS ACHIEVED WHEN AN ARRAY OF SOLID VIAS IS INCORPORATED IN THE CENTER LAND PATTERN.

**SMT APPLICATION NOTES**

1. THE USER MAY MODIFY THE PCB LAND PATTERN DIMENSIONS BASED ON THEIR EXPERIENCE AND/OR PROCESS CAPABILITY.
2. THE LAND PATTERN CORRESPONDING TO THE PACKAGE EXPOSED PAD (IN THE CENTER) CAN BE LARGER, AND WITH DIFFERENT SHAPE THAN THE EXPOSED PAD ON THE PACKAGE. HOWEVER, THE SOLDERABLE AREA, AS DEFINED BY THE SOLDER MASK (SMD), OR NON-SOLDER MASK DEFINED (NSMD), SHOULD BE AS SHOWN FOR THE BEST THERMAL & ELECTRICAL PERFORMANCE.
3. MAXIMUM THERMAL AND ELECTRICAL PERFORMANCE IS ACHIEVED WHEN AN ARRAY OF SOLID VIAS IS INCORPORATED IN THE CENTER LAND PATTERN. (See Options 1 & 2)
4. THE VIAS SHOULD BE AT 0.8 TO 1.2MM PITCH WITH 0.30 TO 0.40MM DIAMETER, AND 1 OZ COPPER VIA BARREL PLATING.
5. NON SOLDER MASK DEFINED (NSMD) PAD DESIGN IS RECOMMENDED FOR PERIMETER LANDS.
6. A LASER-CUT STAINLESS STEEL STENCIL IS RECOMMENDED WITH ELECTRO POLISHED TRAPEZOIDAL WALLS, THE RECOMMENDED STENCIL THICKNESS IS 0.125 mm FOR PITCHES 0.4 and 0.5 mm.
7. RECOMMENDED STENCIL AREA & ASPECT RATIOS ARE 0.66 & 1.5 RESPECTIVELY.
8. RECOMMENDED STENCIL APERTURES ARE AS SHOWN.
9. IT IS RECOMMENDED TO USE "NO-CLEAN", TYPE 3 SOLDER PASTE.
10. THE REFLOW PROFILE DEPENDS ON THE EXACT SOLDER PASTE USED AND THE GIVEN BOARD DETAILS, SUCH AS GEOMETRY, COMPONENTS ETC.

**DETAIL "A" - STENCIL OPENING for PERIMETER LANDS**

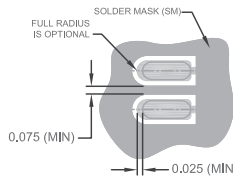

**DETAIL "B" - THERMAL VIAS and STENCIL OPENING for CENTER PAD**

**OPTION 1**  
(NON-PLUGGED THERMAL VIAS)

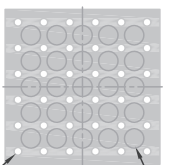

THERMAL VIAS: Ø0.30mm,  
6x6 MATRIX @ 1.00mm PITCH  
STENCIL OPENINGS: Ø0.7-0.8mm  
5x5 MATRIX

**OPTION 2**  
(PLUGGED THERMAL VIAS)

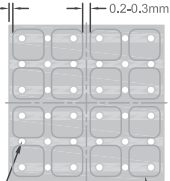

THERMAL VIAS: Ø0.30mm,  
6x6 MATRIX @ 1.00mm PITCH  
STENCIL OPENINGS: 1.2x1.2mm  
4x4 MATRIX

**OPTION 3**  
(PLUGGED THERMAL VIAS)

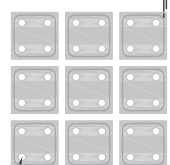

Thermal Vias: Ø0.30mm,  
9X 2x2 Matrix @ 1.00mm Pitch  
Stencil Openings: 1.6x1.6mm  
3x3 Matrix

UNLESS OTHERWISE SPECIFIED DIMENSIONS ARE IN MILLIMETERS AND TOLERANCES ARE: DECIMAL XX ±0.1 XX.X ±0.05 X.XXX ±0.025	THIRD ANGLE PROJECTION		Note: For the most current package drawings, see the Microchip Packaging Specification at <a href="http://www.microchip.com/packaging">http://www.microchip.com/packaging</a>
INTERPRET DIM AND TOL PER ASME Y14.5M - 1994			<b>TITLE</b> PACKAGE DATA 72 PINS QFN-6004, 10x10mm BODY, 0.5mm PITCH, 6.0x6.0mm EXPOSED PAD, 0.4mm LEAD LENGTH <b>Application Notes</b>
MATERIAL	DRAWN	DATE	DWG NUMBER
-	-	3/7/08	AP-72QFN-6004-10x10B
FINISH	CHECKED	DATE	REV
-	-	3/7/08	C
PRINT WITH "SCALE TO FIT" DO NOT SCALE DRAWING	APPROVED	DATE	SCALE    STD COMPLIANCE    SHEET
	S.K.JLIEV	4/14/08	1:1    MO-220    2 OF 2

## Legacy SMSC Packaging Outlines and Dimensions

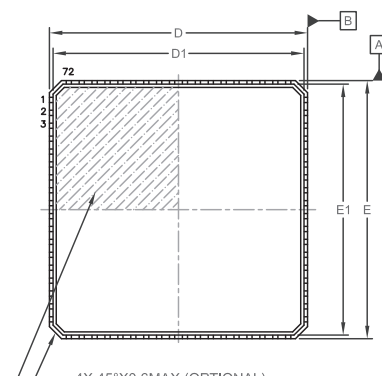

**TOP VIEW**

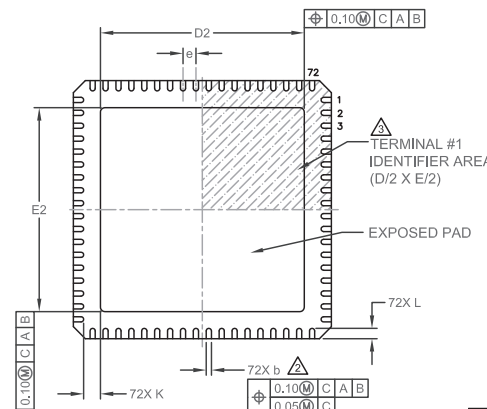

**BOTTOM VIEW**



**SIDE VIEW**

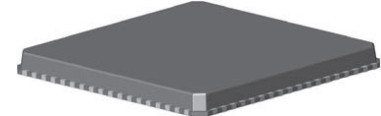

**3-D VIEW**

**4X 45°X0.6MAX (OPTIONAL)**

TERMINAL #1 IDENTIFIER AREA

TERMINAL #1 IDENTIFIER AREA (D/2 X E/2)

EXPOSED PAD

COMMON DIMENSIONS

SYMBOL	MIN	NOM	MAX	NOTE	REMARK
A	0.80	0.85	1.00	-	OVERALL PACKAGE HEIGHT
A1	0	0.02	0.05	-	STANDOFF
A2	-	0.65	0.80	-	MOLD CAP THICKNESS
D/E	9.90	10.00	10.10	-	X/Y BODY SIZE
D1/E1	9.65	9.75	9.85	-	X/Y MOLD CAP SIZE
D2/E2	7.80	7.90	8.00	-	X/Y EXPOSED PAD SIZE
L	0.30	0.40	0.50	-	TERMINAL LENGTH
b	0.18	0.25	0.30	2	TERMINAL WIDTH
K	0.55	0.65	-	-	CENTER PAD TO PIN CLEARANCE
e	0.50 BSC		-	-	TERMINAL PITCH

**NOTES:**

- ALL DIMENSIONS ARE IN MILLIMETER.
- DIMENSIONS "b" APPLIES TO PLATED TERMINALS AND IT IS MEASURED BETWEEN 0.15 AND 0.30 mm FROM THE TERMINAL TIP.
- DETAILS OF TERMINAL #1 IDENTIFIER ARE OPTIONAL BUT MUST BE LOCATED WITHIN THE AREA INDICATED. THE TERMINAL #1 IDENTIFIER MAY BE EITHER A MOLD OR MARKED FEATURE.

REV	DESCRIPTION	DATE	RELEASED BY
A	INITIAL RELEASE	5/29/12	SK1

<small>UNLESS OTHERWISE SPECIFIED DIMENSIONS ARE IN MILLIMETERS AND TOLERANCES ARE: DECIMAL X.X ±0.1 X.XX ±0.05 X.XXX ±0.025 ANGULAR ±1° INTERPRET DIM AND TOL PER ASME Y14.5M - 1994</small>	THIRD ANGLE PROJECTION		<small>Note: For the most current package drawings, see the Microchip Packaging Specification at <a href="http://www.microchip.com/packaging">http://www.microchip.com/packaging</a></small>																			
		<table border="1" style="width: 100%; border-collapse: collapse;"> <tr> <th>NAME</th> <th>DATE</th> </tr> <tr> <td>DRAWN</td> <td>4/7/12</td> </tr> <tr> <td>CHECKED</td> <td>5/7/12</td> </tr> <tr> <td>APPROVED</td> <td>5/29/12</td> </tr> </table>		NAME	DATE	DRAWN	4/7/12	CHECKED	5/7/12	APPROVED	5/29/12	<table border="1" style="width: 100%; border-collapse: collapse;"> <tr> <th colspan="2">TITLE</th> </tr> <tr> <td colspan="2" style="text-align: center;">PACKAGE DATA</td> </tr> <tr> <td colspan="2" style="text-align: center;">72 PINS QFN-7904, 10x10mm BODY, 0.5mm PITCH, 7.9x7.9mm EXPOSED PAD, 0.4mm LEAD LENGTH</td> </tr> <tr> <td colspan="2" style="text-align: center;">Package Outline Drawing (POD)</td> </tr> <tr> <th>DWG NUMBER</th> <th>REV</th> </tr> <tr> <td style="text-align: center;">AP-72QFN-7904-10x10B</td> <td style="text-align: center;">A</td> </tr> </table>	TITLE		PACKAGE DATA		72 PINS QFN-7904, 10x10mm BODY, 0.5mm PITCH, 7.9x7.9mm EXPOSED PAD, 0.4mm LEAD LENGTH		Package Outline Drawing (POD)		DWG NUMBER	REV
NAME	DATE																					
DRAWN	4/7/12																					
CHECKED	5/7/12																					
APPROVED	5/29/12																					
TITLE																						
PACKAGE DATA																						
72 PINS QFN-7904, 10x10mm BODY, 0.5mm PITCH, 7.9x7.9mm EXPOSED PAD, 0.4mm LEAD LENGTH																						
Package Outline Drawing (POD)																						
DWG NUMBER	REV																					
AP-72QFN-7904-10x10B	A																					
<small>PRINT WITH "SCALE TO FIT" DO NOT SCALE DRAWING</small>	<table border="1" style="width: 100%; border-collapse: collapse;"> <tr> <th>SCALE</th> <th>STD COMPLIANCE</th> <th>SHEET</th> </tr> <tr> <td style="text-align: center;">1:1</td> <td style="text-align: center;">MO-220</td> <td style="text-align: center;">1 OF 1</td> </tr> </table>	SCALE	STD COMPLIANCE	SHEET	1:1	MO-220	1 OF 1															
SCALE	STD COMPLIANCE	SHEET																				
1:1	MO-220	1 OF 1																				

---

---

## Legacy SMSC Packaging Outlines and Dimensions

---

---

### **SQFN**

SMSC Legacy

## Legacy SMSC Packaging Outlines and Dimensions

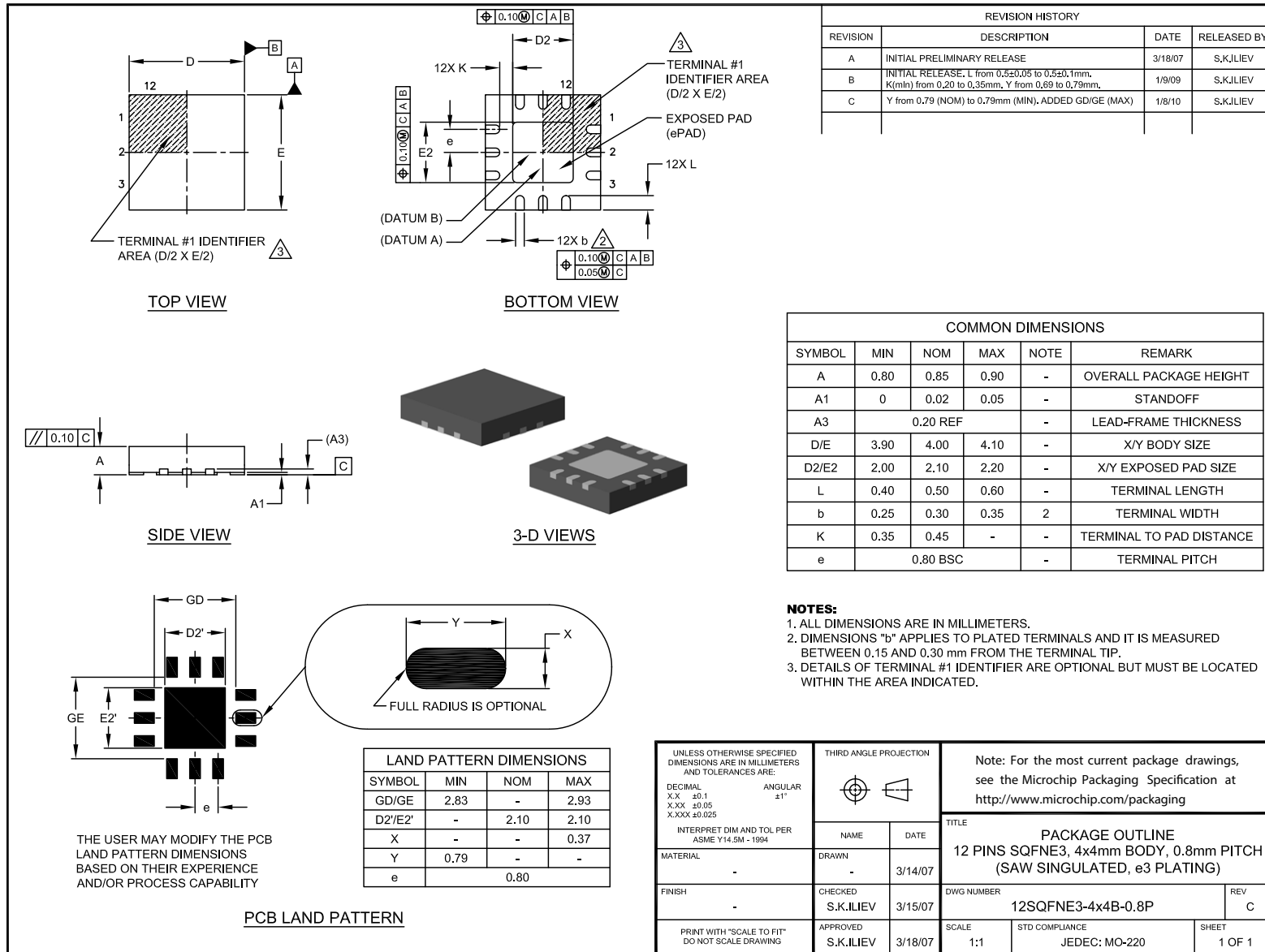



## Legacy SMSC Packaging Outlines and Dimensions

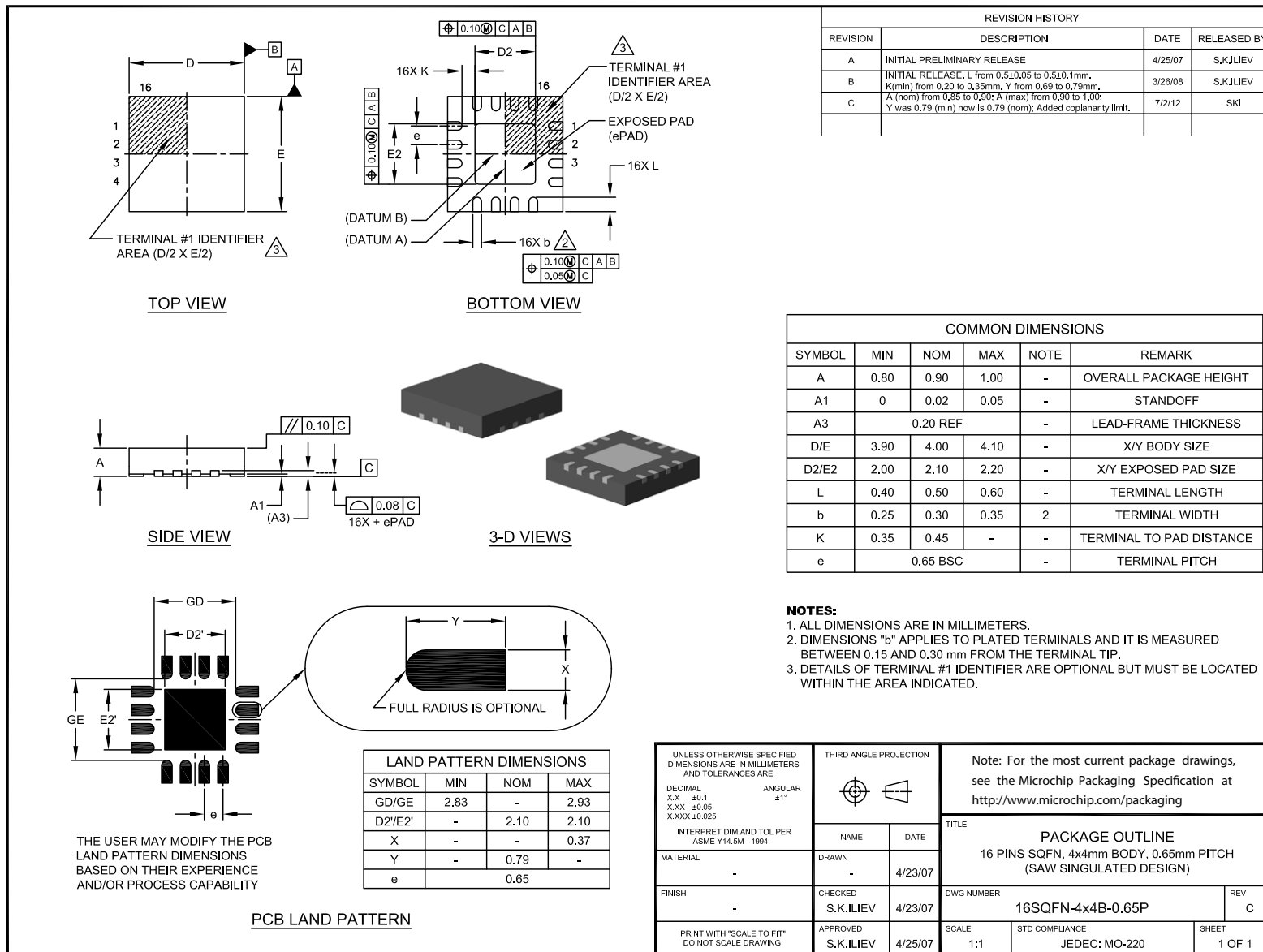

## Legacy SMSC Packaging Outlines and Dimensions

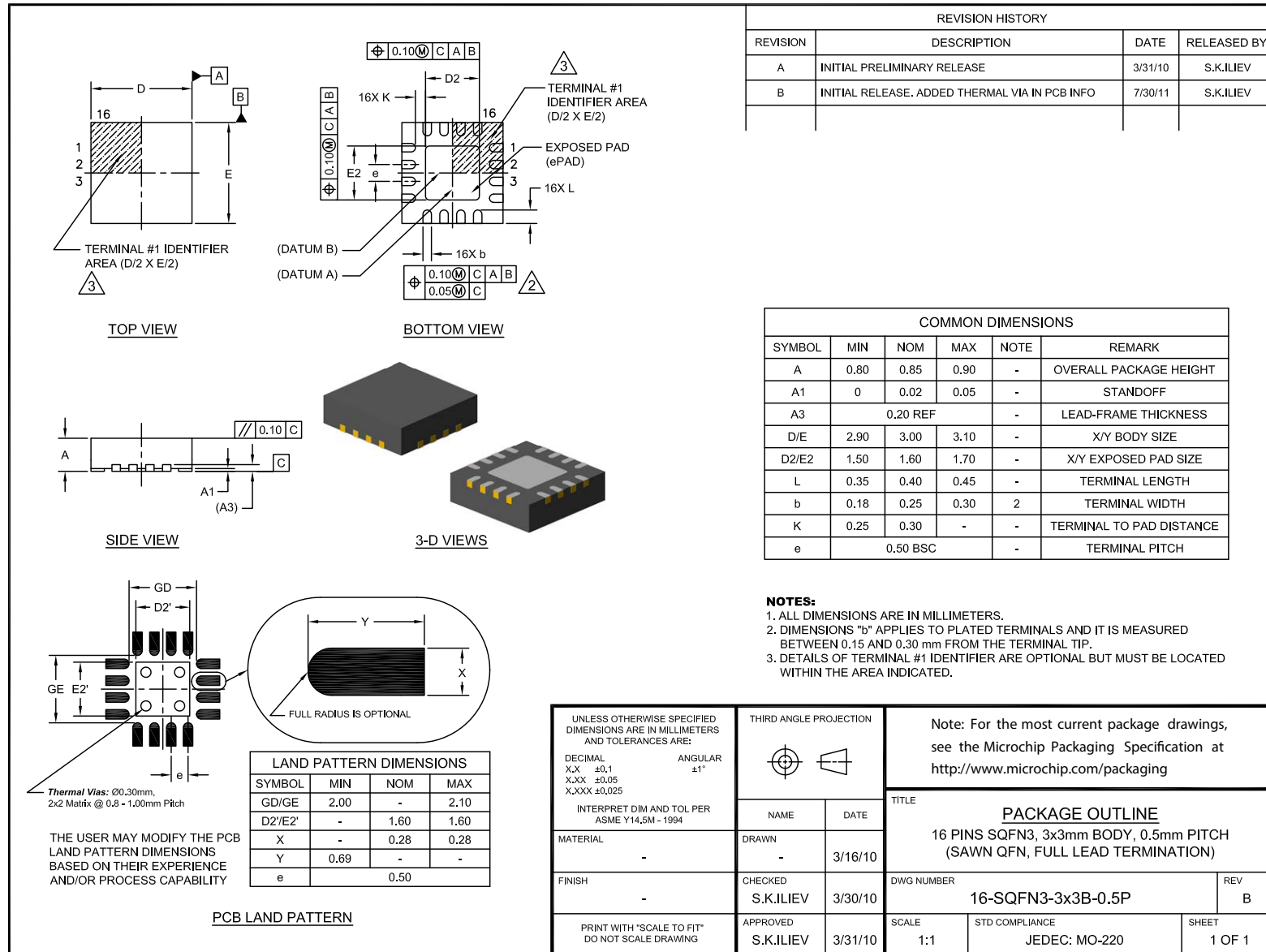

## Legacy SMSC Packaging Outlines and Dimensions

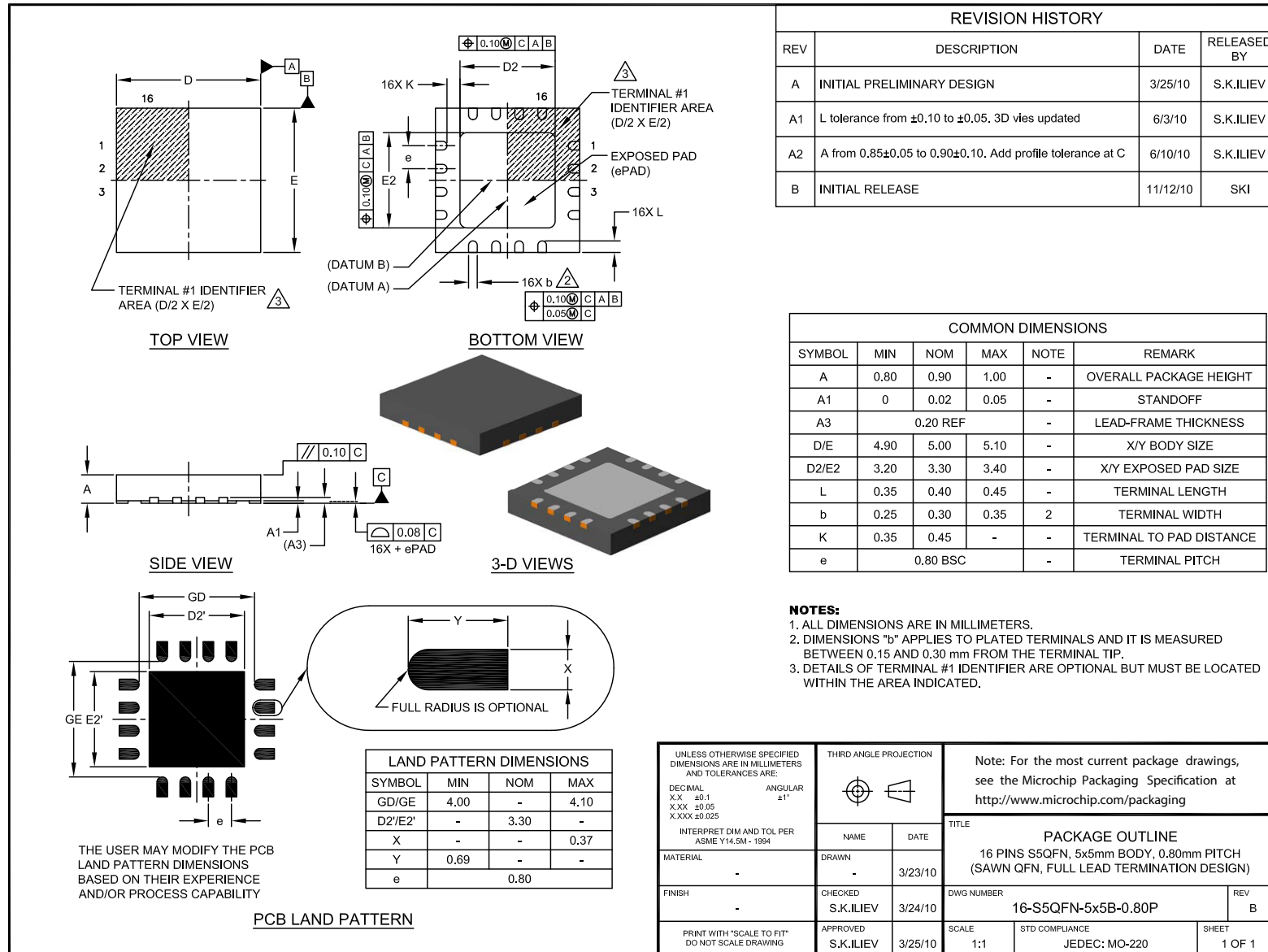

## Legacy SMSC Packaging Outlines and Dimensions

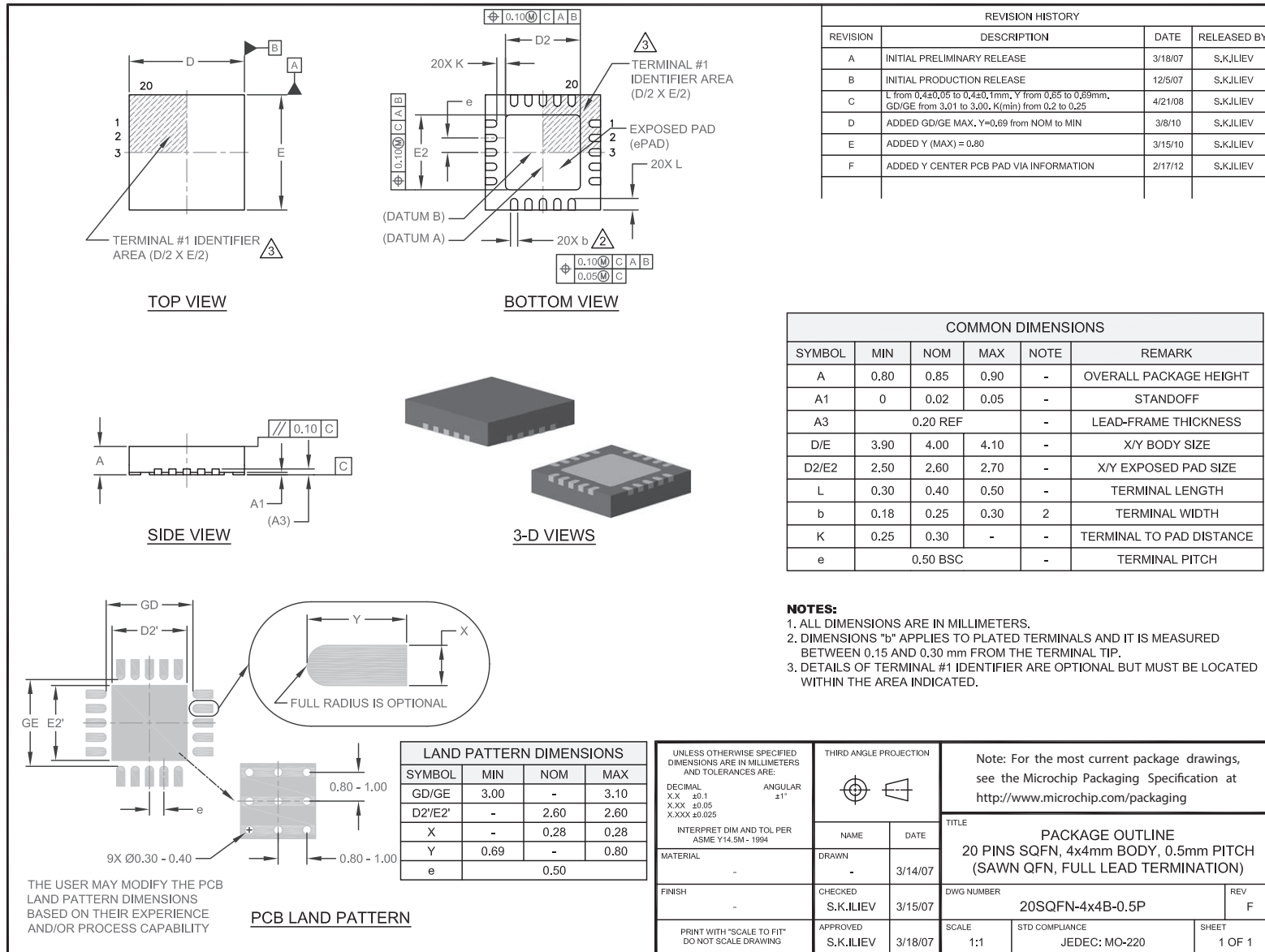

## Legacy SMSC Packaging Outlines and Dimensions

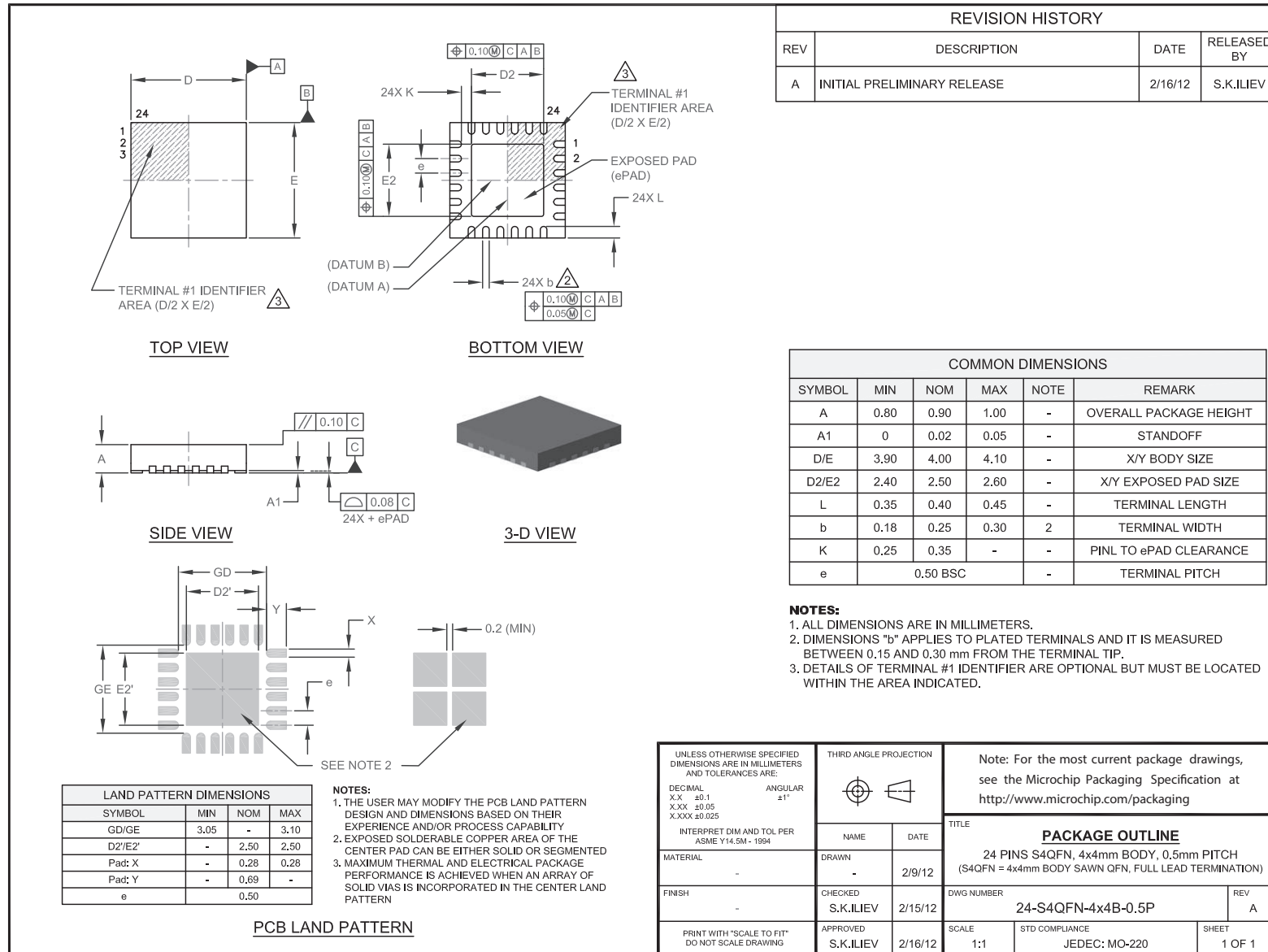

## Legacy SMSC Packaging Outlines and Dimensions

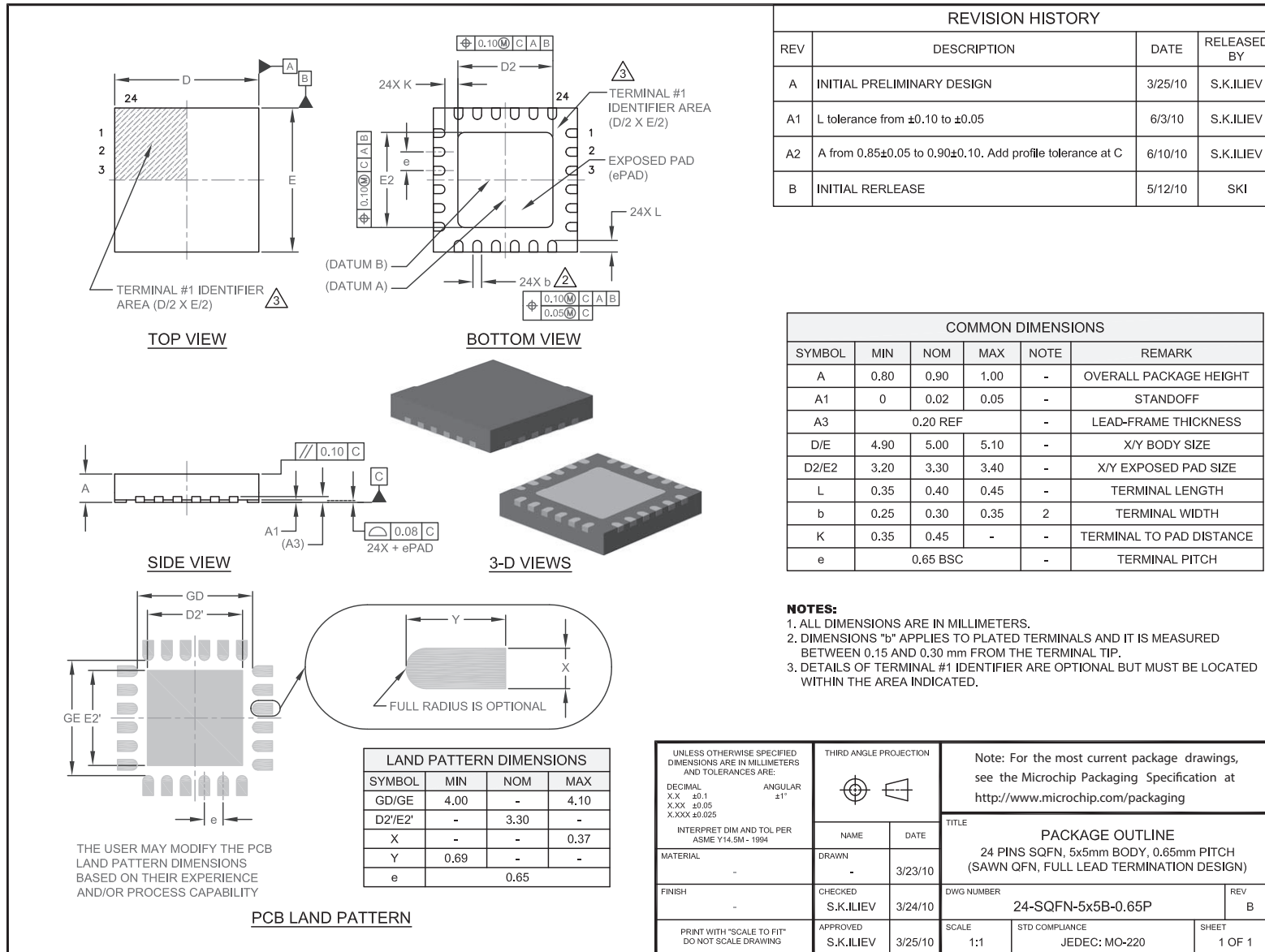

## Legacy SMSC Packaging Outlines and Dimensions

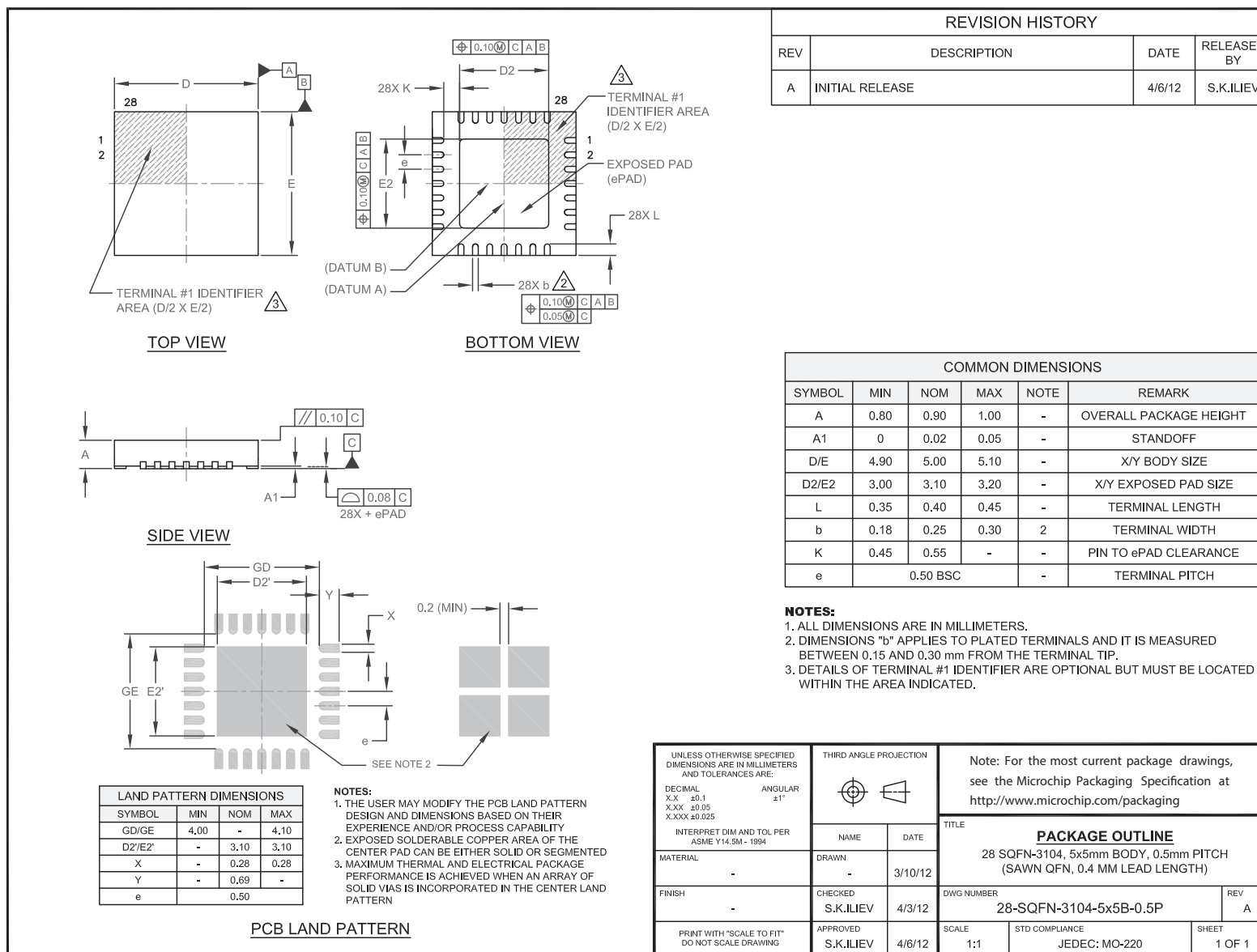

## Legacy SMSC Packaging Outlines and Dimensions

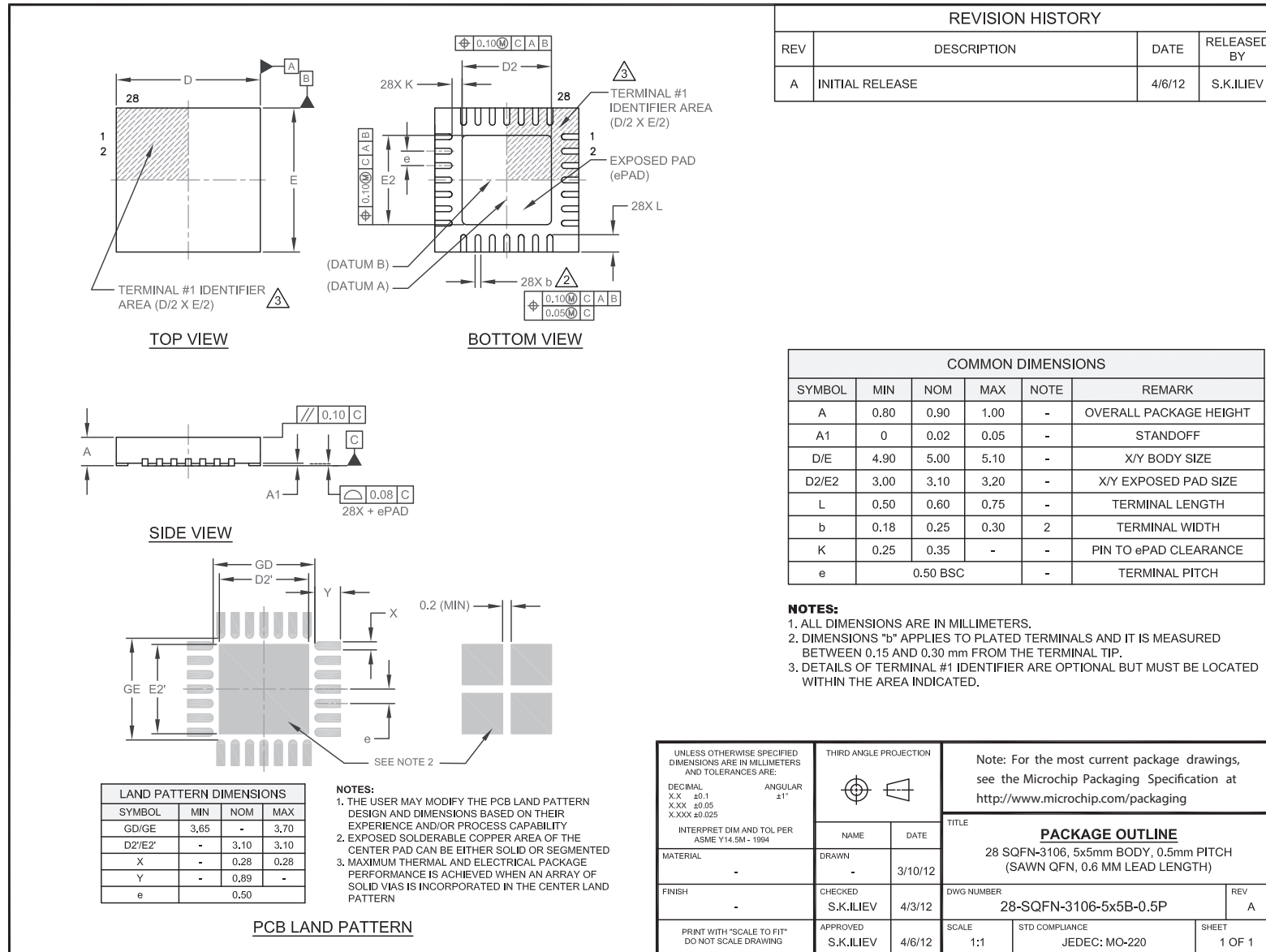



## Legacy SMSC Packaging Outlines and Dimensions

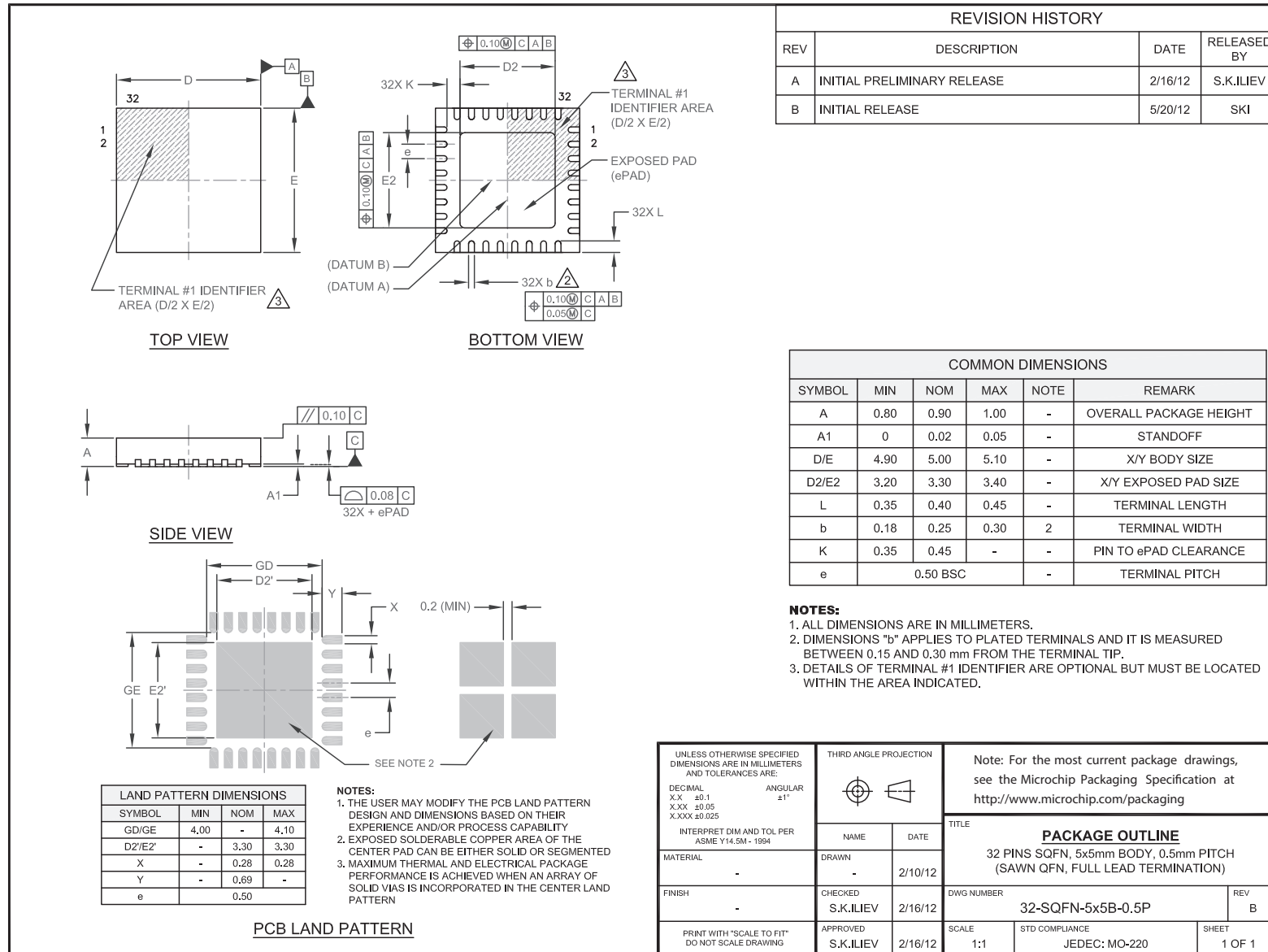

## Legacy SMSC Packaging Outlines and Dimensions

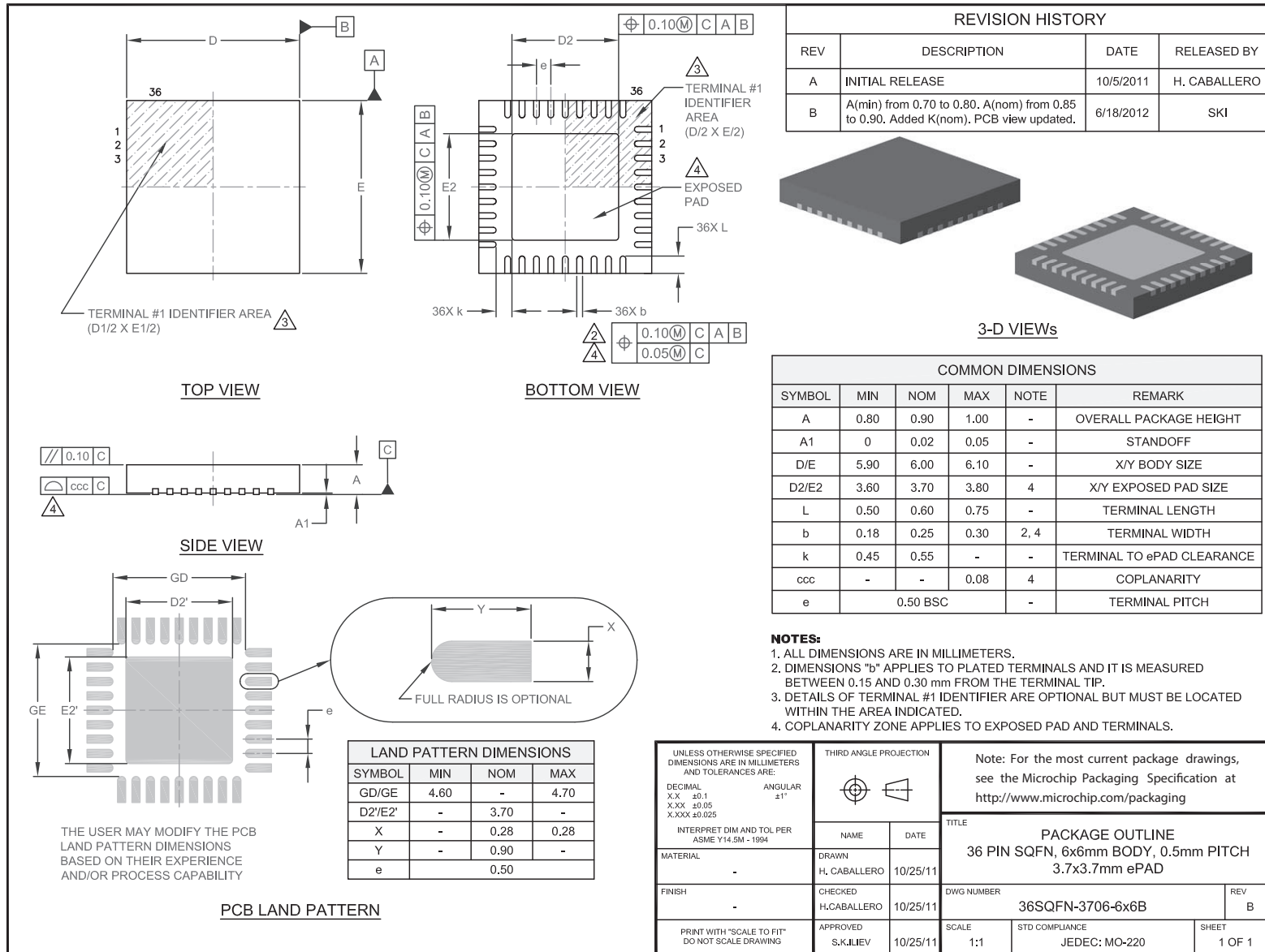

## Legacy SMSC Packaging Outlines and Dimensions

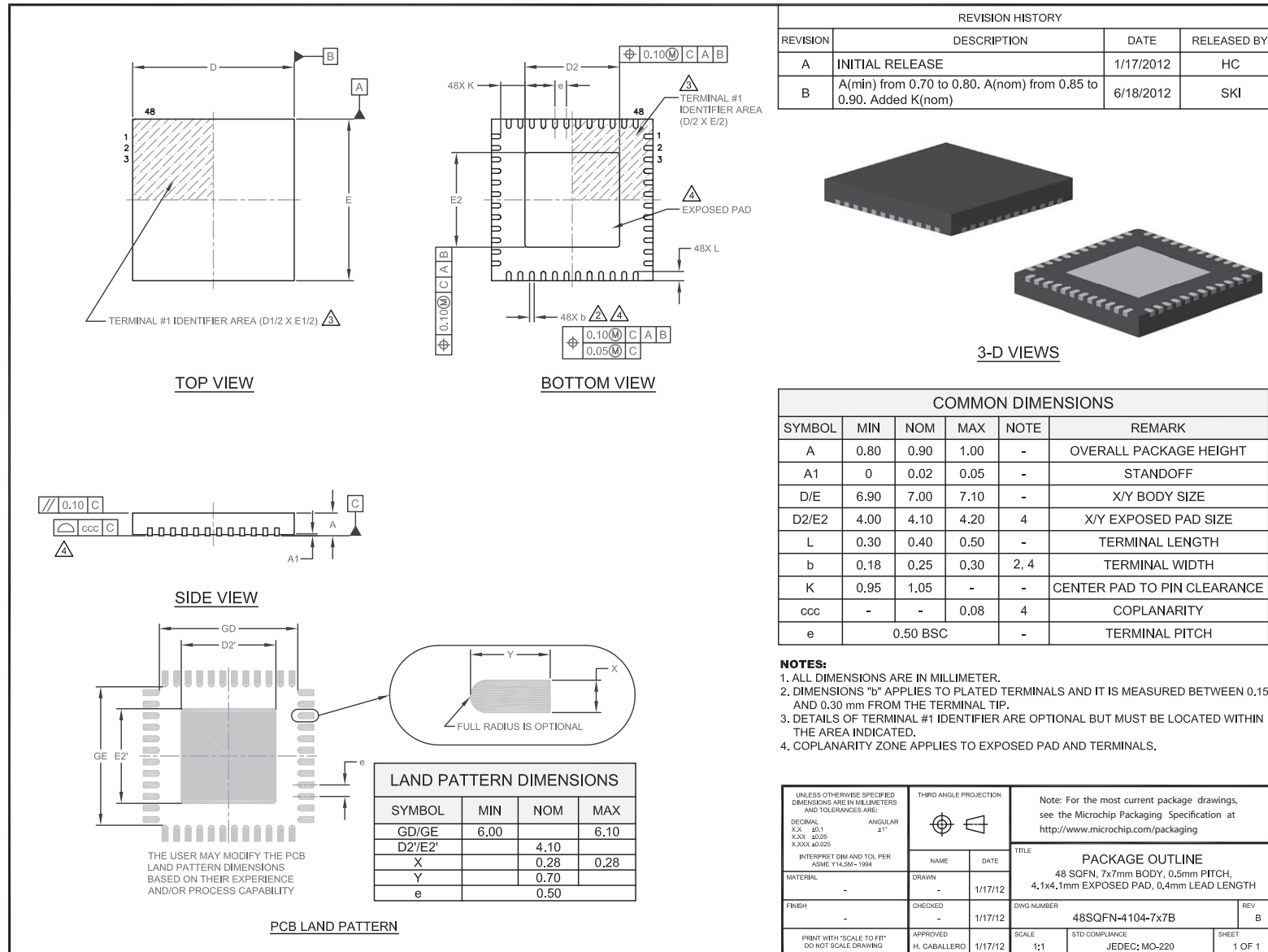

## Legacy SMSC Packaging Outlines and Dimensions

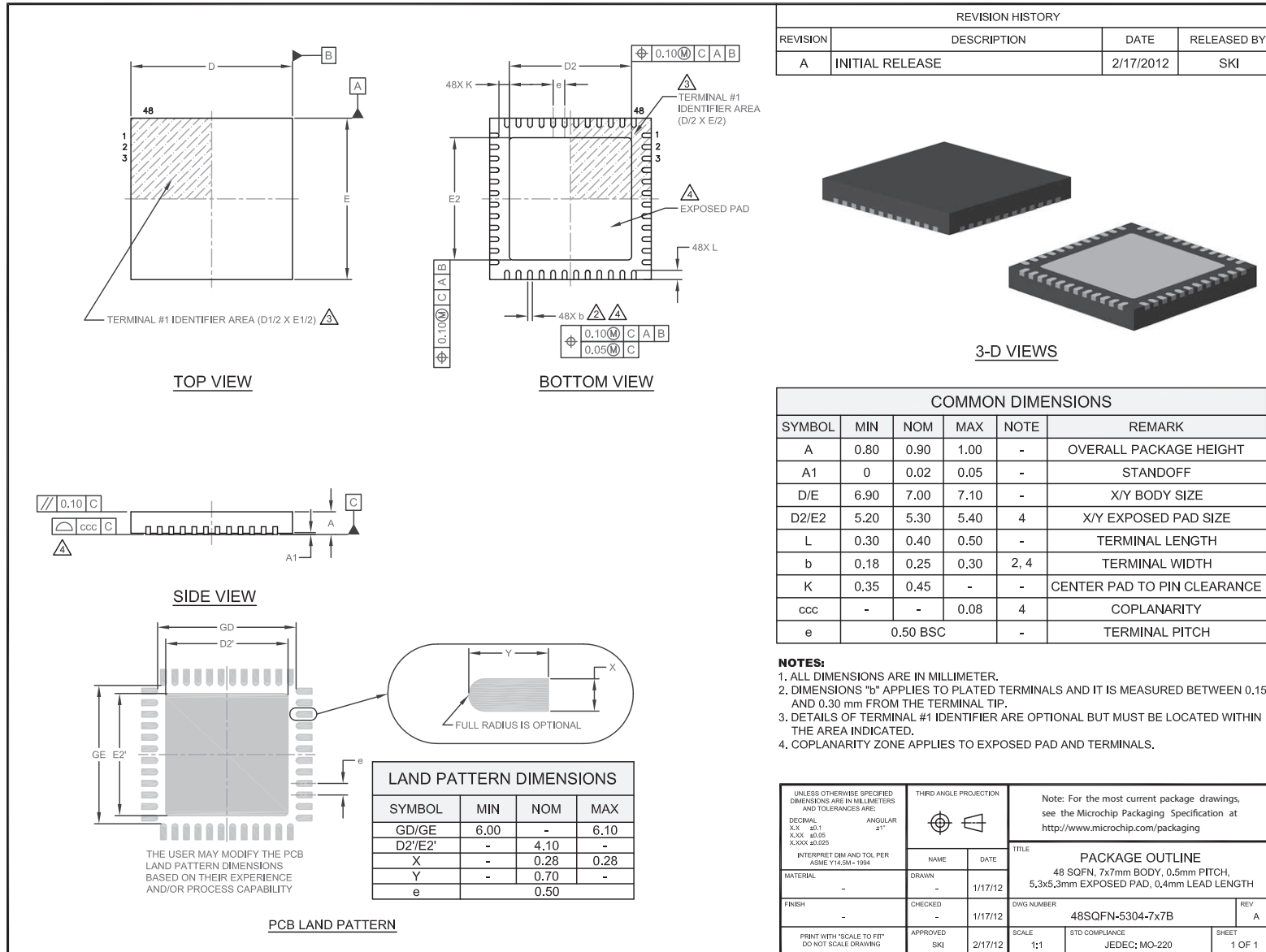

---

---

## Legacy SMSC Packaging Outlines and Dimensions

---

---

### **QFP**

SMSC Legacy

## Legacy SMSC Packaging Outlines and Dimensions

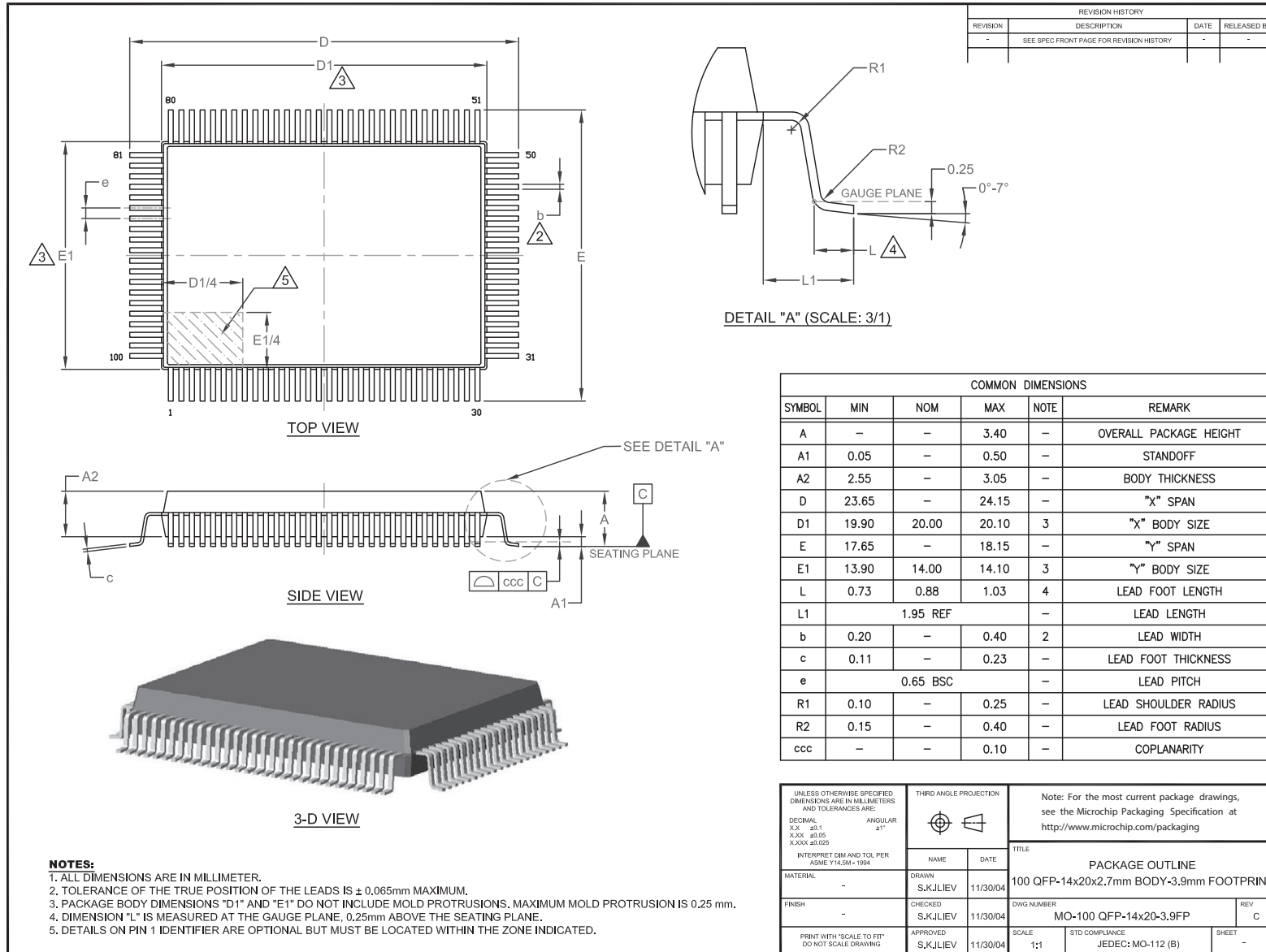

## Legacy SMSC Packaging Outlines and Dimensions

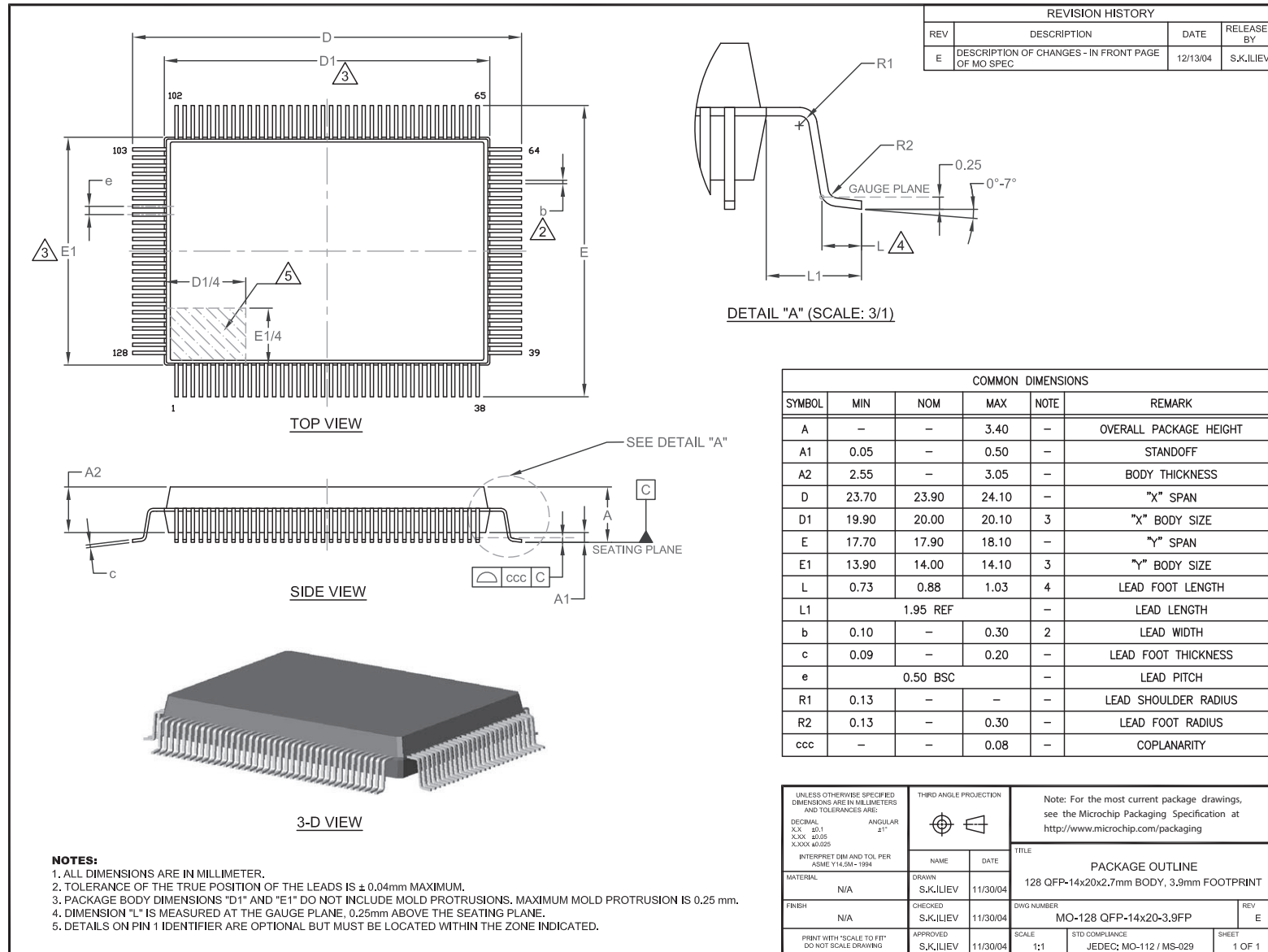

## Legacy SMSC Packaging Outlines and Dimensions

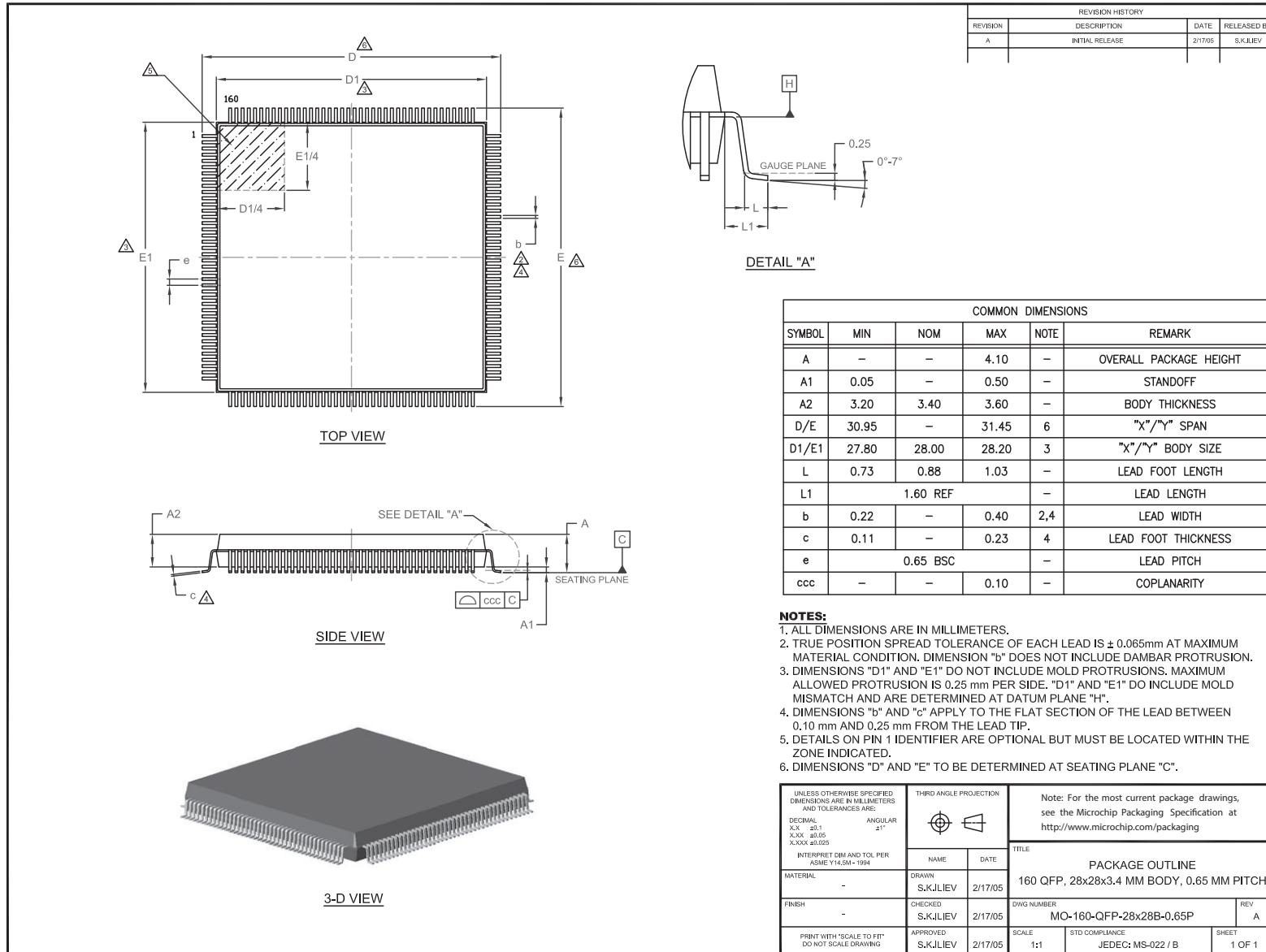



## Legacy SMSC Packaging Outlines and Dimensions

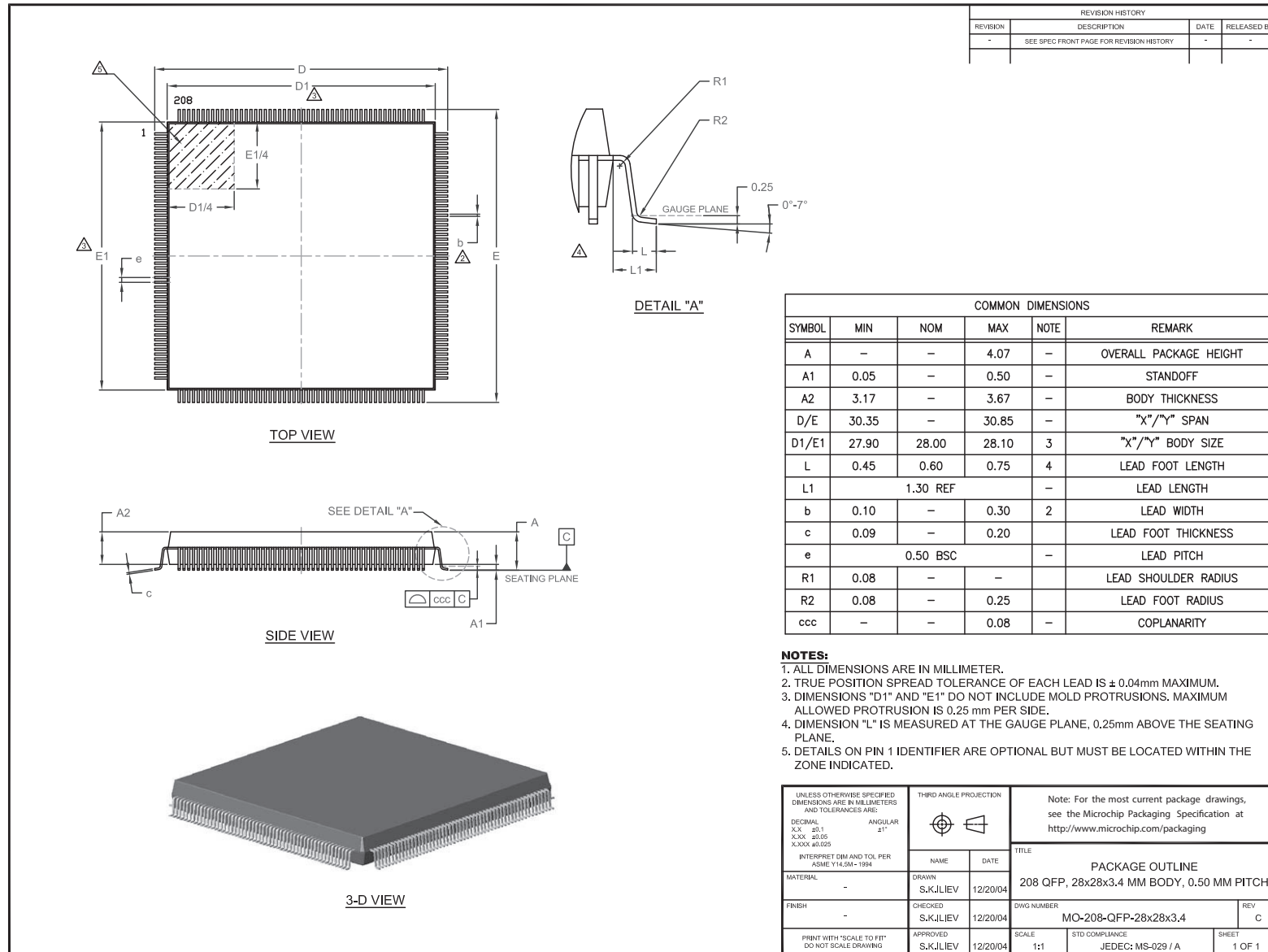



**MICROCHIP**

---

---

**Legacy SMSC Packaging Outlines and Dimensions**

---

---

**NOTES:**

---

---

## Legacy SMSC Packaging Outlines and Dimensions

---

---

### **SIP**

SMSC Legacy

## Legacy SMSC Packaging Outlines and Dimensions

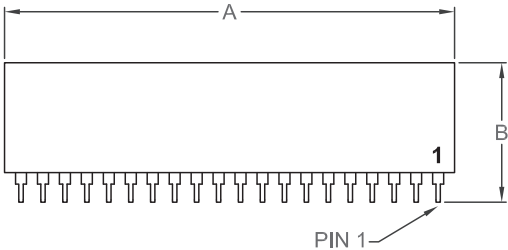

**TOP VIEW**

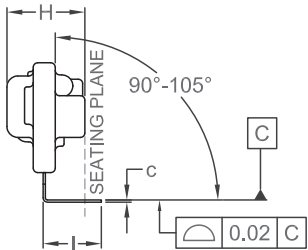

**END VIEW**

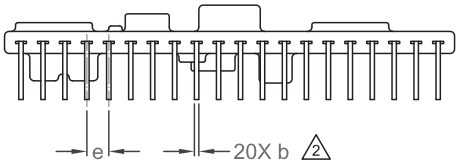

**SIDE VIEW**

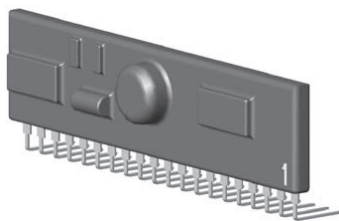

**3-D VIEW**

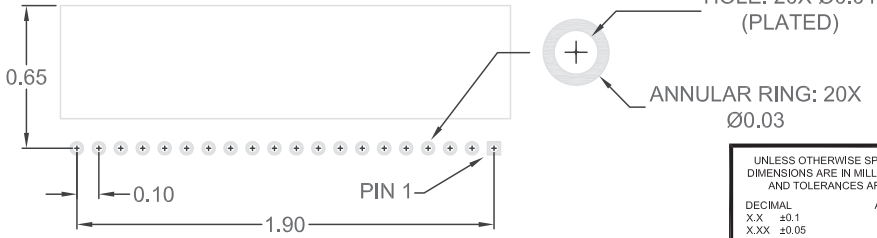

**RECOMMENDED PCB LAND PATTERN**

THE USER MAY MODIFY THE PCB LAND PATTERN DIMENSIONS BASED ON THEIR EXPERIENCE AND/OR PROCESS CAPABILITY

REVISION HISTORY			
REVISION	DESCRIPTION	DATE	RELEASED BY
A	CONVERTING THE DRAWING TO DWG FORMAT	6/23/06	S.K.ILIEV
A	PCB LAND PATTERN IS ADDED	9/23/08	S.K.ILIEV

COMMON DIMENSIONS					
SYMBOL	MIN	NOM	MAX	NOTE	REMARK
A	2.000	-	2.100	-	OVERALL PACKAGE LENGTH
B	0.625	0.650	0.675	-	PACKAGE WIDTH
H	-	-	0.400	-	PACKAGE HEIGHT
I	0.250	-	0.265	-	LEAD LENGTH (BENT TO TIP)
b	0.018	-	0.022	2	LEAD WIDTH
c	0.008	0.010	0.012	-	LEAD THICKNESS
e	0.100 BSC			-	LEAD PITCH

**NOTES:**

- ALL DIMENSIONS ARE IN INCHES.
- TRUE POSITION SPREAD TOLERANCE OF EACH LEAD IS  $\pm 0.02$  INCHES AT MAXIMUM MATERIAL CONDITIONS. PINS MUST BE CUT STRAIGHT, AND THE CUTTING EDGE MUST BE PARALLEL TO THE PACKAGE BODY WITHIN 0.005 INCHES.

UNLESS OTHERWISE SPECIFIED DIMENSIONS ARE IN MILLIMETERS AND TOLERANCES ARE:

DECIMAL	ANGULAR
X.X ±0.1	±1°
X.XX ±0.05	
X.XXX ±0.025	

INTERPRET DIM AND TOL PER ASME Y14.5M - 1994

MATERIAL	-
FINISH	-

PRINT WITH "SCALE TO FIT"  
DO NOT SCALE DRAWING

THIRD ANGLE PROJECTION

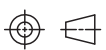

NAME	DATE	Note: For the most current package drawings, see the Microchip Packaging Specification at <a href="http://www.microchip.com/packaging">http://www.microchip.com/packaging</a>		
DRAWN				
CHECKED		<b>TITLE</b> PACKAGE OUTLINE 20 LEADS SIP, 0.100 INCHES PITCH (RIGHT ANGLE LEAD DESIGN)		
APPROVED		<b>DWG NUMBER</b> PS-HYC9088-20SIP-R		
		SCALE	STD COMPLIANCE	SHEET
		1:1	N/A	1 OF 1

---

---

## Legacy SMSC Packaging Outlines and Dimensions

---

---

### **QLeX**

SMSC Legacy

## Legacy SMSC Packaging Outlines and Dimensions

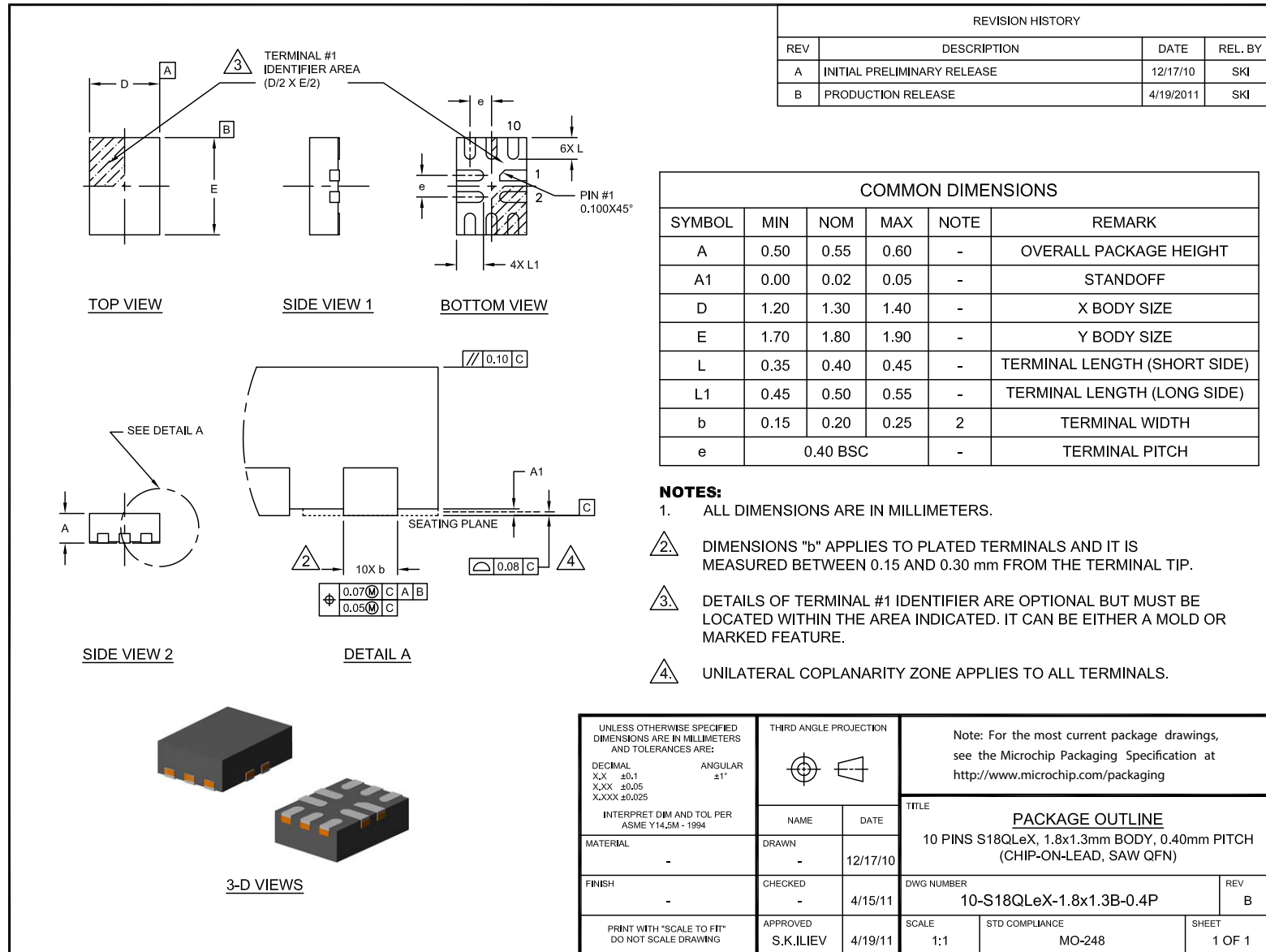

## Legacy SMSC Packaging Outlines and Dimensions

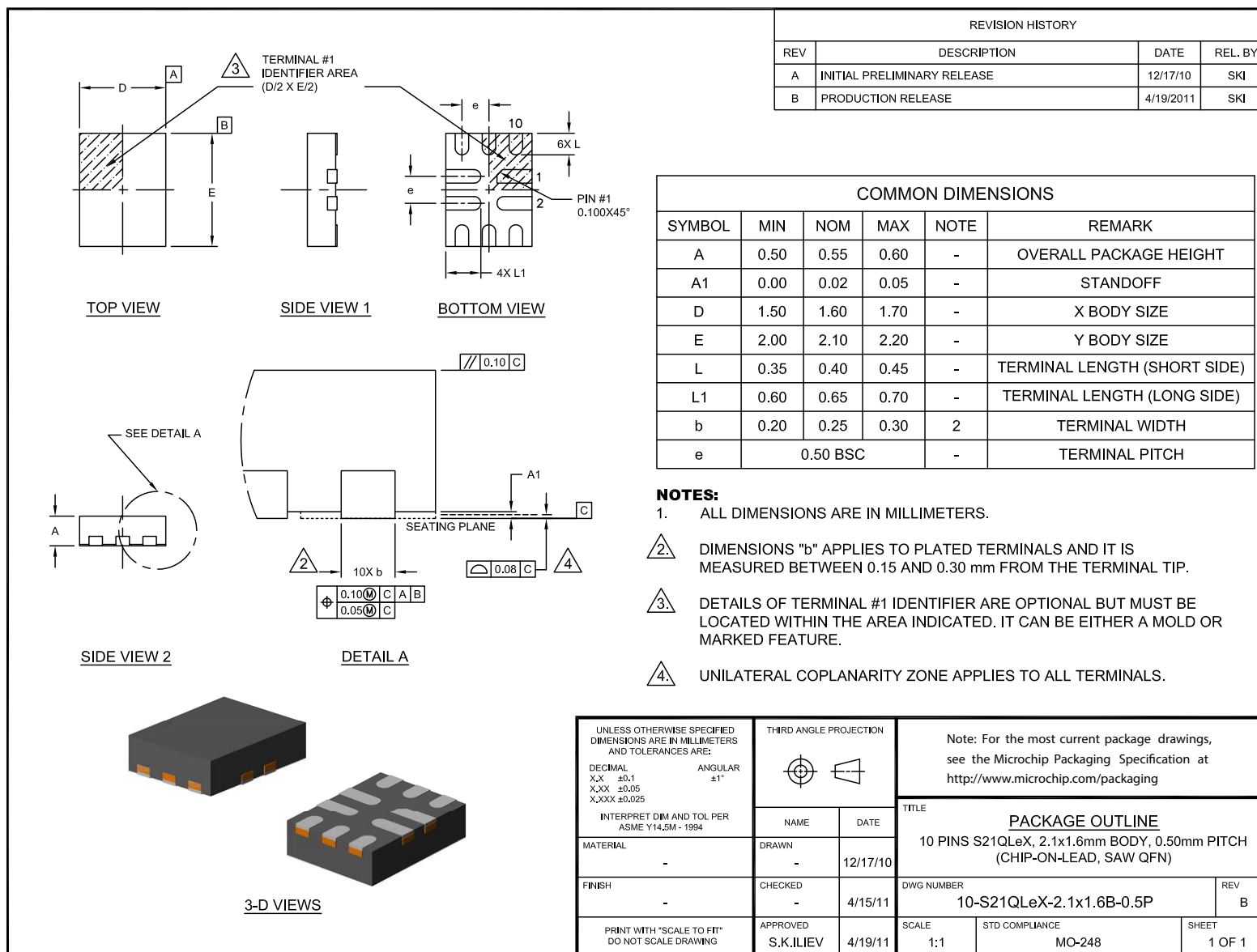



**MICROCHIP**

---

---

**Legacy SMSC Packaging Outlines and Dimensions**

---

---

**NOTES:**



---

---

**Legacy SMSC Packaging Outlines and Dimensions**

---

---

**SOT-23**

SMSC Legacy

## Legacy SMSC Packaging Outlines and Dimensions

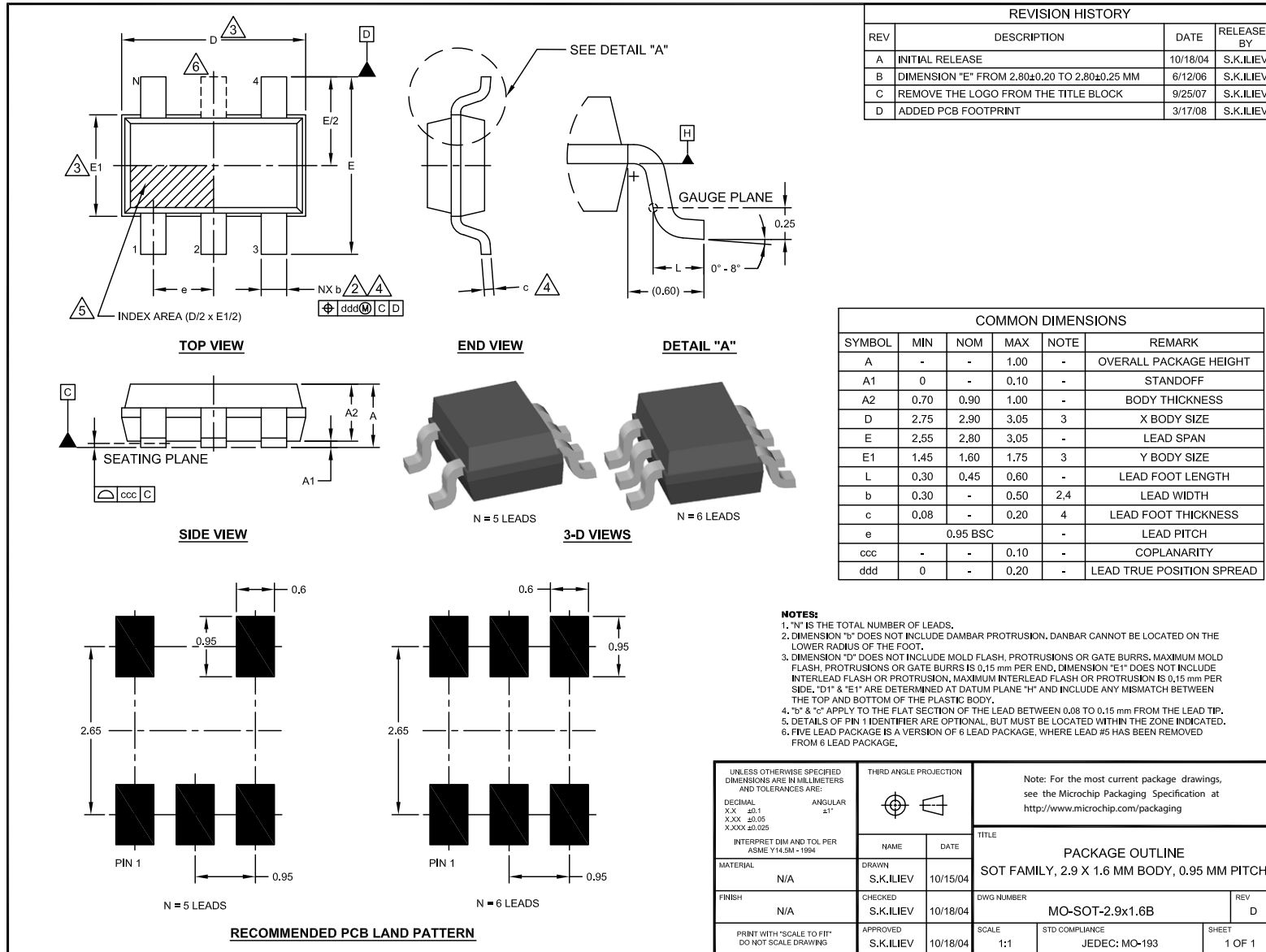

REVISION HISTORY			
REV	DESCRIPTION	DATE	RELEASED BY
A	INITIAL RELEASE	10/18/04	S.K.ILIEV
B	DIMENSION "E" FROM 2.80±0.20 TO 2.80±0.25 MM	6/12/06	S.K.ILIEV
C	REMOVE THE LOGO FROM THE TITLE BLOCK	9/25/07	S.K.ILIEV
D	ADDED PCB FOOTPRINT	3/17/08	S.K.ILIEV

COMMON DIMENSIONS					
SYMBOL	MIN	NOM	MAX	NOTE	REMARK
A	-	-	1.00	-	OVERALL PACKAGE HEIGHT
A1	0	-	0.10	-	STANDOFF
A2	0.70	0.90	1.00	-	BODY THICKNESS
D	2.75	2.90	3.05	3	X BODY SIZE
E	2.55	2.80	3.05	-	LEAD SPAN
E1	1.45	1.60	1.75	3	Y BODY SIZE
L	0.30	0.45	0.60	-	LEAD FOOT LENGTH
b	0.30	-	0.50	2,4	LEAD WIDTH
c	0.08	-	0.20	4	LEAD FOOT THICKNESS
e	0.95 BSC			-	LEAD PITCH
ccc	-	-	0.10	-	COPLANARITY
ddd	0	-	0.20	-	LEAD TRUE POSITION SPREAD

- NOTES:**
- "N" IS THE TOTAL NUMBER OF LEADS.
  - DIMENSION "b" DOES NOT INCLUDE MOLD FLASH, PROTRUSIONS OR GATE BURRS. DANBAR CANNOT BE LOCATED ON THE LOWER RADIUS OF THE FOOT.
  - DIMENSION "D" DOES NOT INCLUDE MOLD FLASH, PROTRUSIONS OR GATE BURRS. MAXIMUM MOLD FLASH, PROTRUSIONS OR GATE BURRS IS 0.15 mm PER END. DIMENSION "E1" DOES NOT INCLUDE INTERLEAD FLASH OR PROTRUSION, MAXIMUM INTERLEAD FLASH OR PROTRUSION IS 0.15 mm PER SIDE. "D1" & "E1" ARE DETERMINED AT DATUM PLANE "H" AND INCLUDE ANY MISMATCH BETWEEN THE TOP AND BOTTOM OF THE PLASTIC BODY.
  - "b" & "c" APPLY TO THE FLAT SECTION OF THE LEAD BETWEEN 0.08 TO 0.15 mm FROM THE LEAD TIP.
  - DETAILS OF PIN 1 IDENTIFIER ARE OPTIONAL, BUT MUST BE LOCATED WITHIN THE ZONE INDICATED.
  - FIVE LEAD PACKAGE IS A VERSION OF 6 LEAD PACKAGE, WHERE LEAD #5 HAS BEEN REMOVED FROM 6 LEAD PACKAGE.

UNLESS OTHERWISE SPECIFIED DIMENSIONS ARE IN MILLIMETERS AND TOLERANCES ARE: DECIMAL ANGULAR X.X .±0.1 ±1° XXX .±0.05 XXXX ±0.025		THIRD ANGLE PROJECTION		Note: For the most current package drawings, see the Microchip Packaging Specification at <a href="http://www.microchip.com/packaging">http://www.microchip.com/packaging</a>	
INTERPRET DIM AND TOL PER ASME Y14.2M - 1994		NAME	DATE	TITLE	
MATERIAL	N/A	DRAWN	S.K.ILIEV	PACKAGE OUTLINE SOT FAMILY, 2.9 X 1.6 MM BODY, 0.95 MM PITCH	
FINISH	N/A	CHECKED	S.K.ILIEV	DWG NUMBER	REV
PRINT WITH "SCALE TO FIT" DO NOT SCALE DRAWING		APPROVED	S.K.ILIEV	SCALE	STD COMPLIANCE
				1:1	JEDEC: MO-193
					SHEET 1 OF 1

---

---

## Legacy SMSC Packaging Outlines and Dimensions

---

---

### **SOIC**

SMSC Legacy

## Legacy SMSC Packaging Outlines and Dimensions

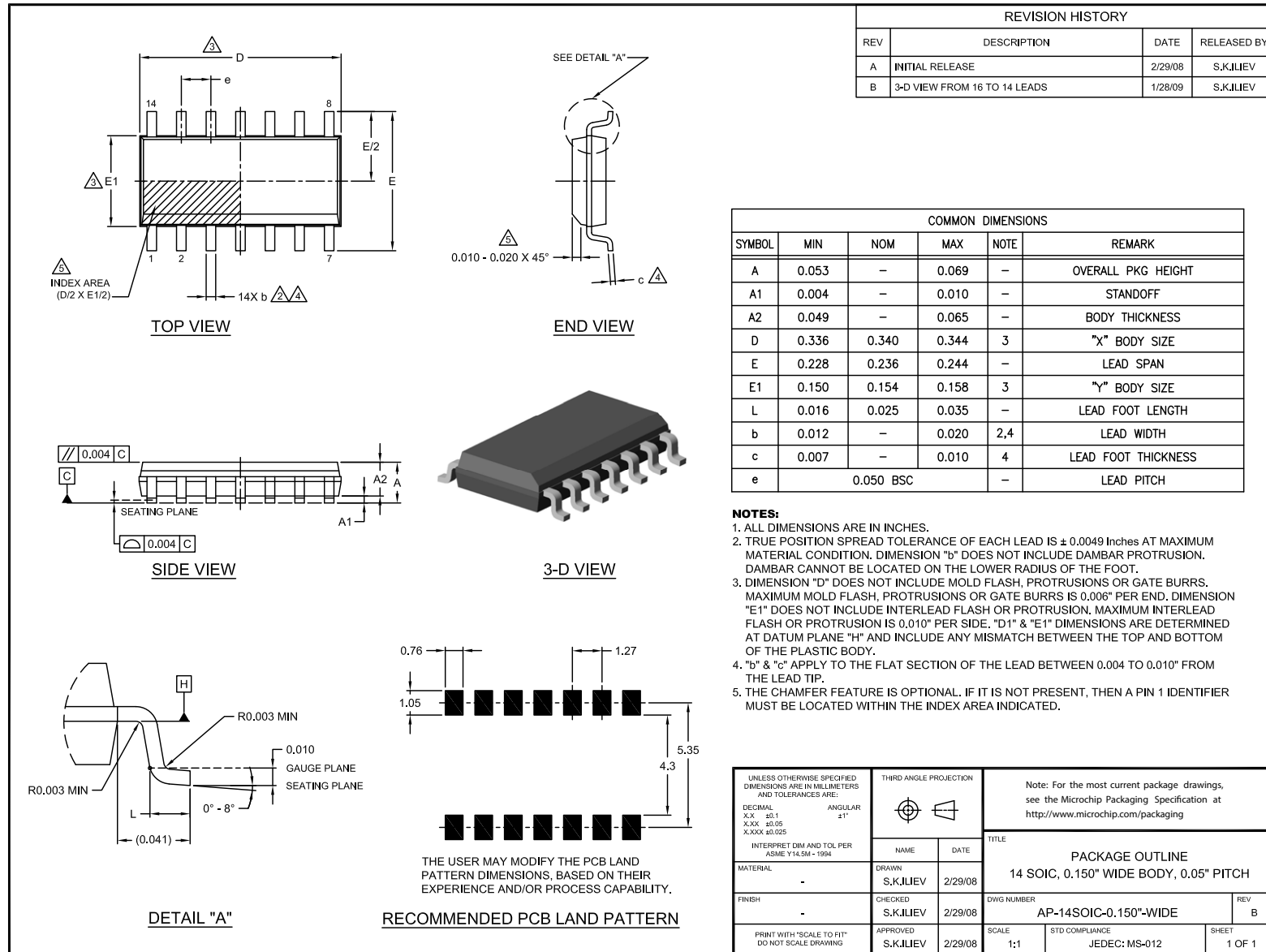

## Legacy SMSC Packaging Outlines and Dimensions

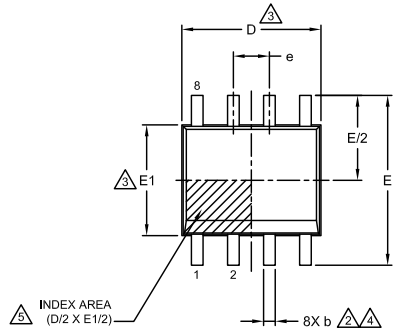

**TOP VIEW**

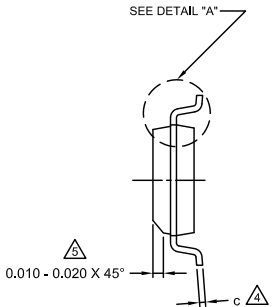

**END VIEW**

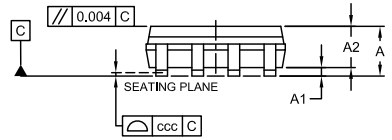

**SIDE VIEW**

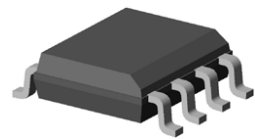

**3-D VIEW**

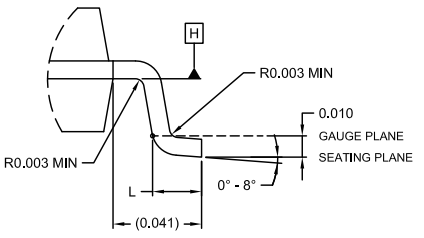

**DETAIL "A"**

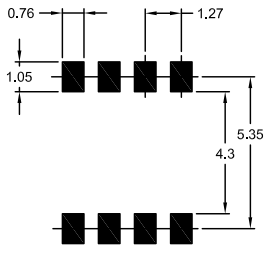

**PCB LAND PATTERN**

THE USER MAY MODIFY THE PCB LAND PATTERN DIMENSIONS, BASED ON THEIR EXPERIENCE AND/OR PROCESS CAPABILITY.

**REVISION HISTORY**

REV	DESCRIPTION	DATE	RELEASED BY
A	INITIAL RELEASE	5/20/04	S.K.ILIEV
B	ADDED PCB LAND PATTERN	7/9/12	SKI

**COMMON DIMENSIONS**

SYMBOL	MIN	NOM	MAX	NOTE	REMARK
A	0.053	-	0.069	-	OVERALL PKG HEIGHT
A1	0.004	-	0.010	-	STANDOFF
A2	0.049	-	0.065	-	BODY THICKNESS
D	0.189	0.193	0.197	3	"X" BODY SIZE
E	0.228	0.236	0.244	-	LEAD SPAN
E1	0.150	0.154	0.158	3	"Y" BODY SIZE
L	0.016	-	0.035	-	LEAD FOOT LENGTH
b	0.012	-	0.020	2,4	LEAD WIDTH
c	0.007	-	0.010	4	LEAD FOOT THICKNESS
e	0.050 BSC			-	LEAD PITCH
ccc	-	-	0.0035	-	COPLANARITY

**NOTES:**

- ALL DIMENSIONS ARE IN INCHES.
- TRUE POSITION SPREAD TOLERANCE OF EACH LEAD IS  $\pm 0.0049$  inches AT MAXIMUM MATERIAL CONDITION. DIMENSION "b" DOES NOT INCLUDE DAMBAR PROTRUSION. DAMBAR CANNOT BE LOCATED ON THE LOWER RADIUS OF THE FOOT.
- DIMENSION "D" DOES NOT INCLUDE MOLD FLASH, PROTRUSIONS OR GATE BURRS. MAXIMUM MOLD FLASH, PROTRUSIONS OR GATE BURRS IS 0.006" PER END. DIMENSION "E1" DOES NOT INCLUDE INTERLEAD FLASH OR PROTRUSION. MAXIMUM INTERLEAD FLASH OR PROTRUSION IS 0.010" PER SIDE. "D1" & "E1" DIMENSIONS ARE DETERMINED AT DATUM PLANE "H" AND INCLUDE ANY MISMATCH BETWEEN THE TOP AND BOTTOM OF THE PLASTIC BODY.
- "b" & "c" APPLY TO THE FLAT SECTION OF THE LEAD BETWEEN 0.004 TO 0.010" FROM THE LEAD TIP.
- THE CHAMFER FEATURE IS OPTIONAL. IF IT IS NOT PRESENT, THEN A PIN 1 IDENTIFIER MUST BE LOCATED WITHIN THE INDEX AREA INDICATED.

UNLESS OTHERWISE SPECIFIED DIMENSIONS ARE IN MILLIMETERS AND TOLERANCES ARE:

DECIMAL            ANGULAR

XX            ±0.1            ±1°

XX.X           ±0.05

XX.XXX       ±0.025

THIRD ANGLE PROJECTION



Note: For the most current package drawings, see the Microchip Packaging Specification at <http://www.microchip.com/packaging>

INTERPRET DIM AND TOL PER ASME Y14.5M - 1994

MATERIAL	DRAWN	DATE
-	S.K.ILIEV	5/17/04
FINISH	CHECKED	DATE
-	S.K.ILIEV	5/19/04
APPROVED	DATE	SCALE
S.K.ILIEV	5/20/04	1:1

TITLE

**PACKAGE OUTLINE**

8 SOIC, 0.150" WIDE BODY, 0.05" PITCH

DWG NUMBER	REV
AP-8SOIC-0.150"-WIDE	B
SCALE	STD COMPLIANCE
1:1	JEDEC: MS-012
SHEET	1 OF 1



**MICROCHIP**

---

---

**Legacy SMSC Packaging Outlines and Dimensions**

---

---

**NOTES:**

---

---

## Legacy SMSC Packaging Outlines and Dimensions

---

---

### **SSOP**

SMSC Legacy

## Legacy SMSC Packaging Outlines and Dimensions

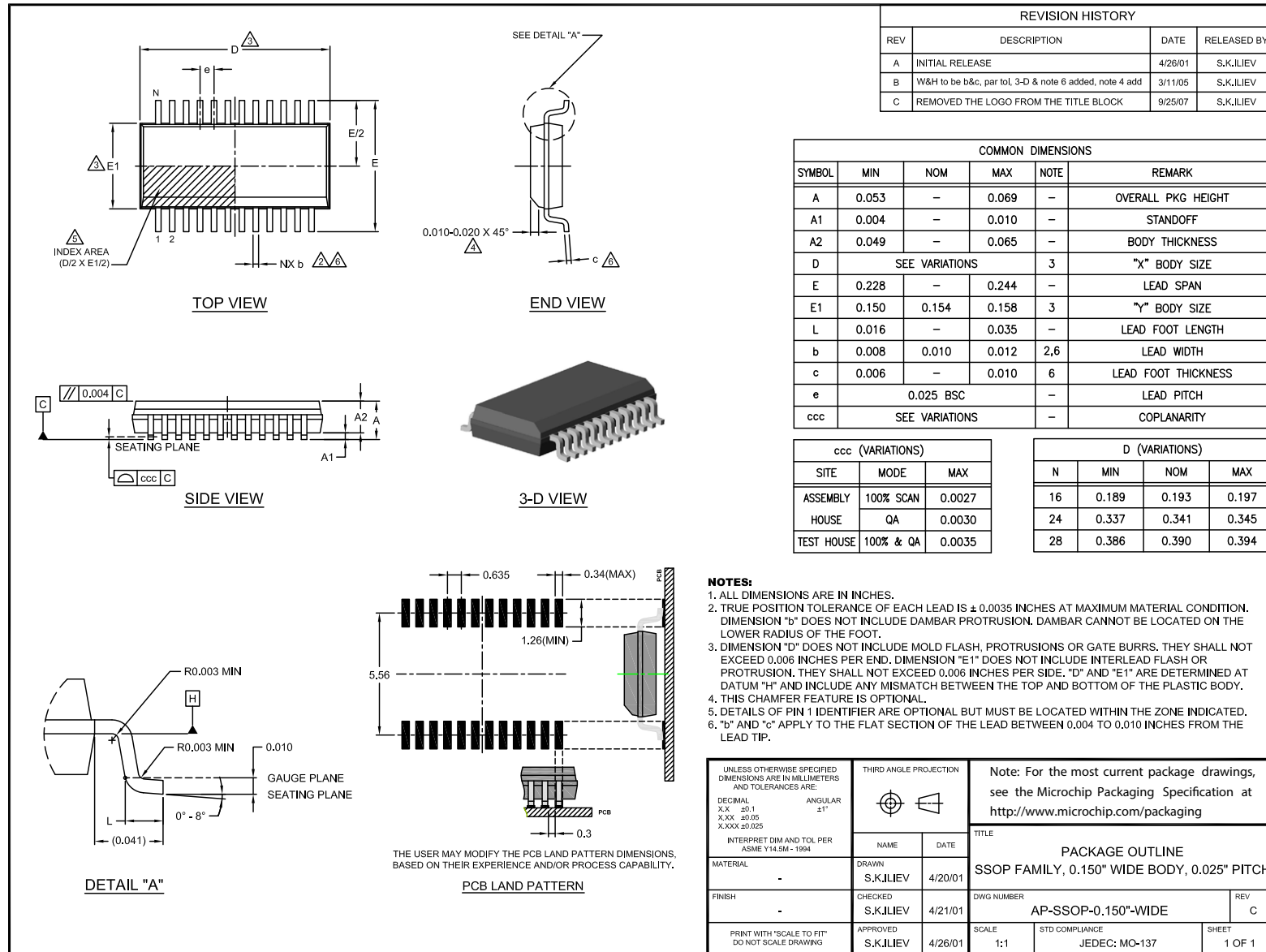



---

---

## Legacy SMSC Packaging Outlines and Dimensions

---

---

### **TDFN**

SMSC Legacy

## Legacy SMSC Packaging Outlines and Dimensions

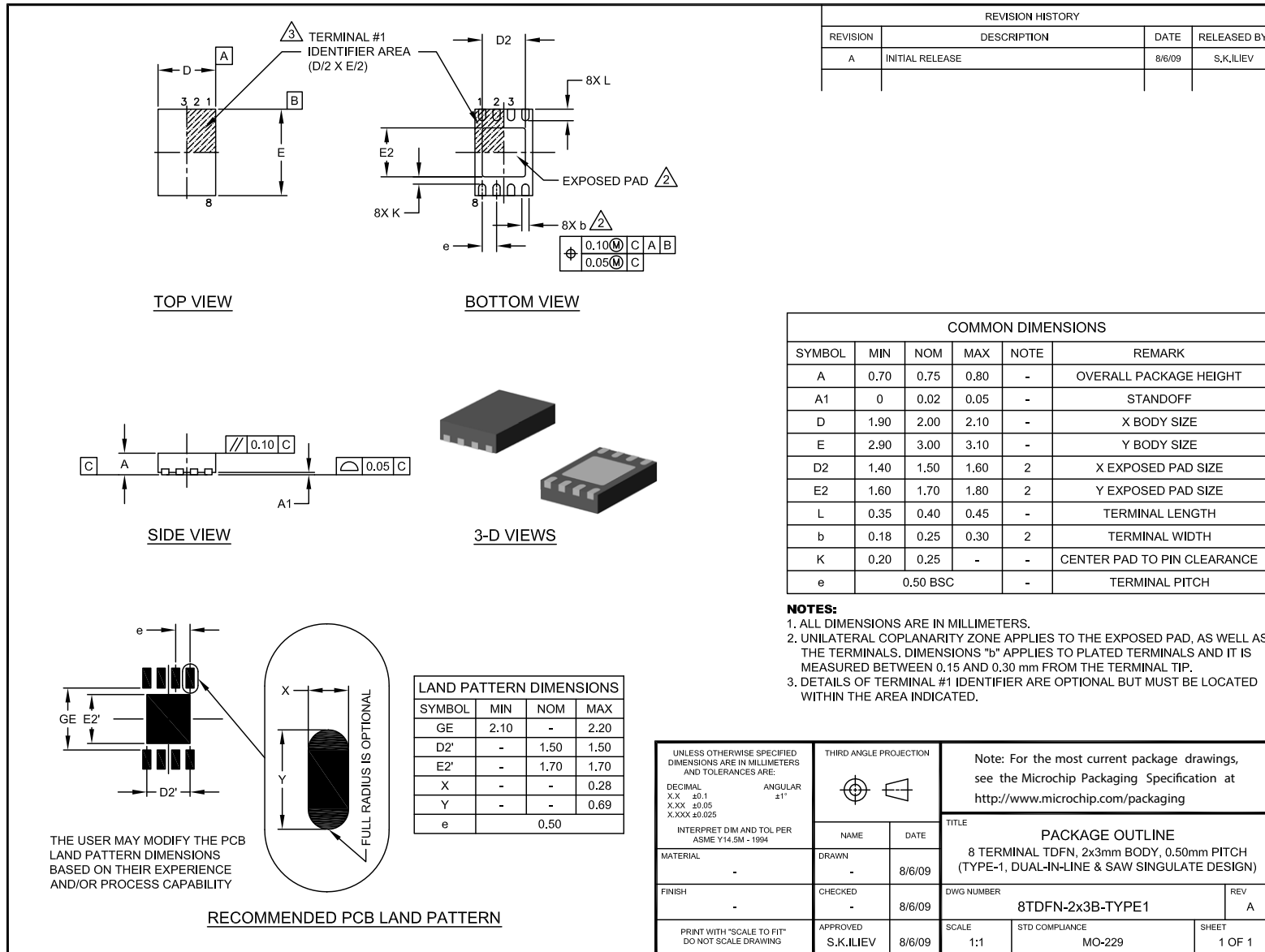

---

---

## Legacy SMSC Packaging Outlines and Dimensions

---

---

### **TFBGA**

SMSC Legacy

## Legacy SMSC Packaging Outlines and Dimensions

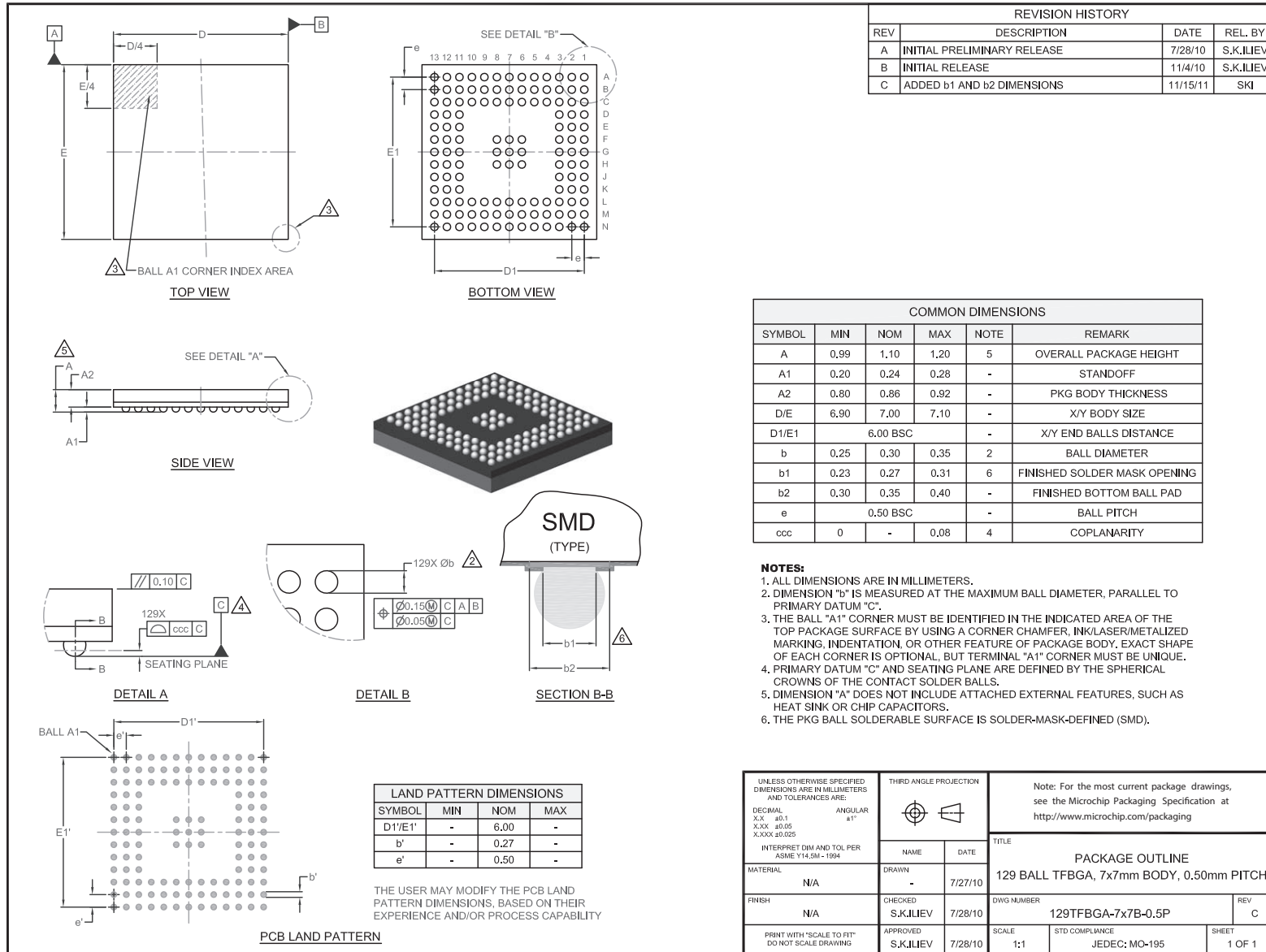

## Legacy SMSC Packaging Outlines and Dimensions

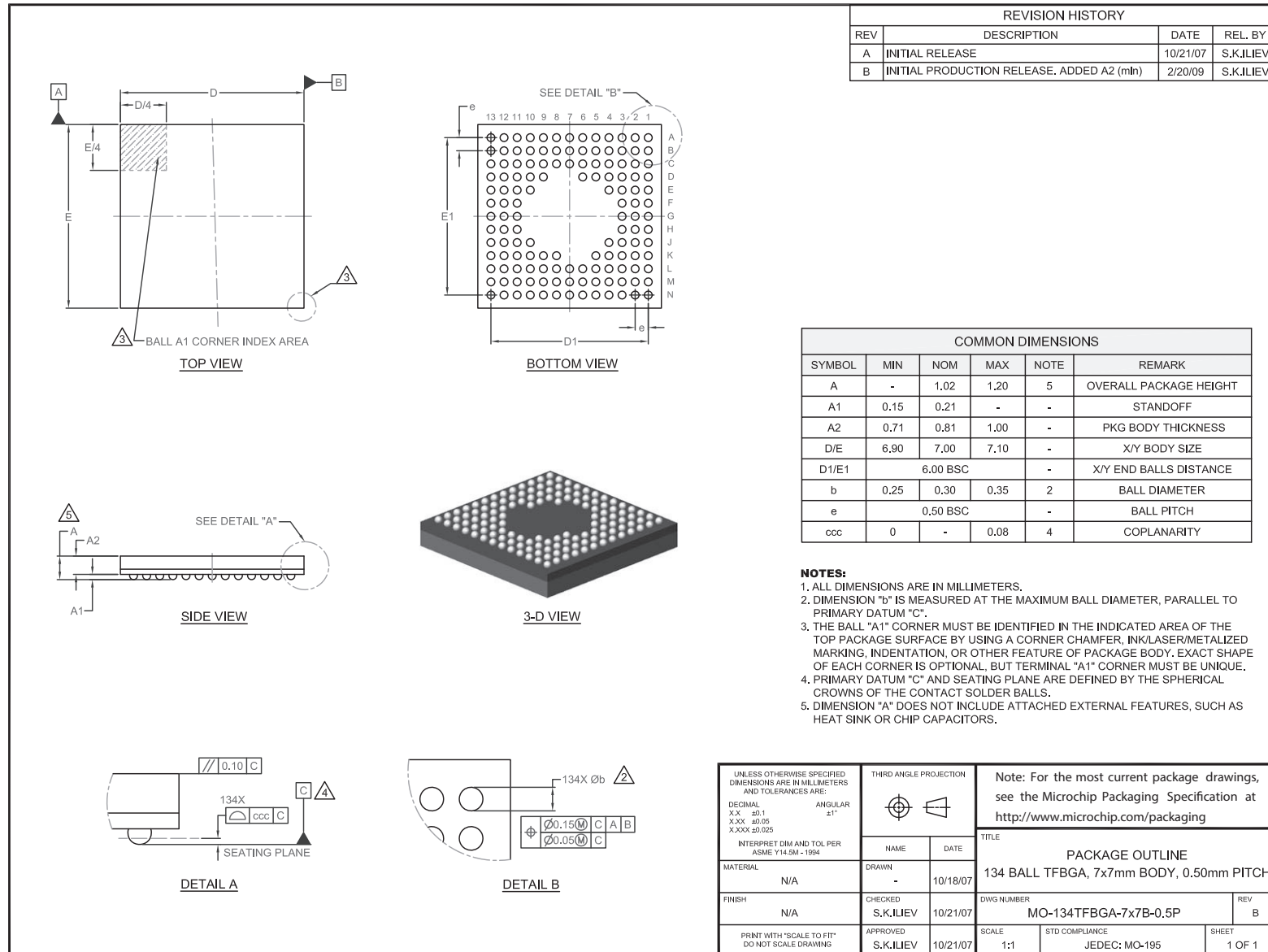

## Legacy SMSC Packaging Outlines and Dimensions

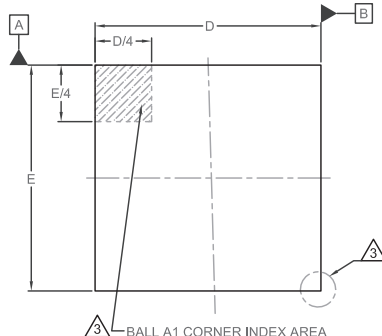

**TOP VIEW**

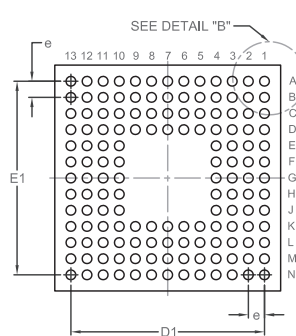

**BOTTOM VIEW**

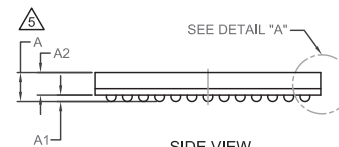

**SIDE VIEW**

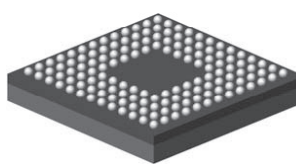

**3-D VIEW**

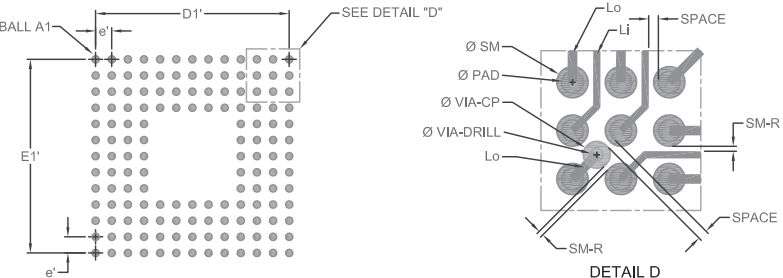

**DETAIL D**

REVISION HISTORY			
REV	DESCRIPTION	DATE	REL. BY
A	INITIAL PRELIMINARY RELEASE	10/21/07	S.K.JLIEV
B	INITIAL RELEASE	11/10/08	S.K.JLIEV
C	b' FROM 0,20-0,25 TO 0,27 (min) and 0,27 (max)	8/10/10	S.K.JLIEV
D	ADDED ROUTING AND SECTION C-C (b1 DIM)	12/11/2010	S.K.JLIEV

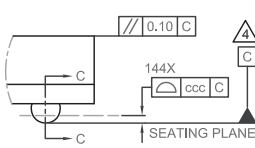
**DETAIL A**

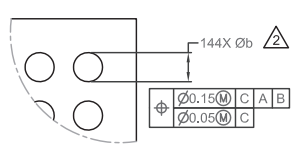

**DETAIL B**

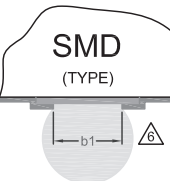

**SECTION C-C**

COMMON DIMENSIONS					
SYMBOL	MIN	NOM	MAX	NOTE	REMARK
A	-	1,02	1,20	5	OVERALL PACKAGE HEIGHT
A1	0,15	0,21	-	-	STANDOFF
A2	-	0,81	1,00	-	PKG BODY THICKNESS
D/E	6,90	7,00	7,10	-	X/Y BODY SIZE
D1/E1	6,00 BSC		-	-	X/Y END BALLS DISTANCE
b	0,25	0,30	0,35	2	BALL DIAMETER
b1	0,24	0,27	0,30	6	BALL SOLDERABLE PAD DIAMETER
e	0,50 BSC		-	-	BALL PITCH
ccc	0	-	0,08	4	COPLANARITY

**NOTES:**

- ALL DIMENSIONS ARE IN MILLIMETERS.
- DIMENSION "b" IS MEASURED AT THE MAXIMUM BALL DIAMETER, PARALLEL TO PRIMARY DATUM C.
- THE BALL "A1" CORNER MUST BE IDENTIFIED IN THE INDICATED AREA OF THE TOP PACKAGE SURFACE BY USING A CORNER CHAMFER, INK/LASER/METALIZED MARKING, INDENTATION, OR OTHER FEATURE OF PACKAGE BODY. EXACT SHAPE OF EACH CORNER IS OPTIONAL, BUT TERMINAL "A1" CORNER MUST BE UNIQUE.
- PRIMARY DATUM "C" AND SEATING PLANE ARE DEFINED BY THE SPHERICAL CROWNS OF THE CONTACT SOLDER BALLS.
- DIMENSION "A" DOES NOT INCLUDE ATTACHED EXTERNAL FEATURES, SUCH AS HEAT SINK OR CHIP CAPACITORS.
- THE PKG BALL SOLDERABLE SURFACE IS SOLDER-MASK-DEFINED (SMD) TYPE.

LAND PATTERN DIMENSIONS			
SYMBOL	MIN	NOM	MAX
D1'/E1'	-	6,00	-
e'	-	0,50	-

THE USER MAY MODIFY THE PCB LAND PATTERN DIMENSIONS, BASED ON THEIR EXPERIENCE AND/OR PROCESS CAPABILITY

**PCB LAND PATTERN & ROUTING**

ROUTING DIMENSIONS				
Symbol	Recommended	Acceptable		
Ø PAD	0,27	0,25	0,30	
Ø SM	0,325	0,346	0,325	0,375
Ø VIA-CP	0,28	0,28	N/A	
Ø VIA-DRILL	0,13	0,13	Via-In-Pad	
Lo	0,10	0,10	0,10	
Li	0,075	0,075	N/A	
SPACE (Metal-to-Metal)	0,078	0,088	0,20	
SM-R	0,05	0,04	0,05	-

UNLESS OTHERWISE SPECIFIED DIMENSIONS ARE IN MILLIMETERS AND TOLERANCES ARE:

DECIMAL	ANGULAR
X.X ±0,1	±1°
X.XX ±0,05	
X.XXX ±0,025	

INTERPRET DIM AND TOL PER ASME Y14.5M-1994

THIRD ANGLE PROJECTION		Note: For the most current package drawings, see the Microchip Packaging Specification at <a href="http://www.microchip.com/packaging">http://www.microchip.com/packaging</a>	
NAME	DATE	TITLE	
MATERIAL	N/A	PACKAGE OUTLINE	
DRAWN	S.K.JLIEV 10/18/07		
FINISH	N/A	144 BALL TFBGA, 7x7mm BODY, 0.50mm PITCH	
CHECKED	S.K.JLIEV 10/21/07		
APPROVED	S.K.JLIEV 10/21/07	DWG NUMBER	MO-144TFBGA-7x7B-0.5P
PRINT WITH "SCALE TO FIT" DO NOT SCALE DRAWING		SCALE	1:1
		STD COMPLIANCE	JEDEC: MQ-195
		SHEET	1 OF 1

---

---

**Legacy SMSC Packaging Outlines and Dimensions**

---

---

**TSSOP**

SMSC Legacy

## Legacy SMSC Packaging Outlines and Dimensions

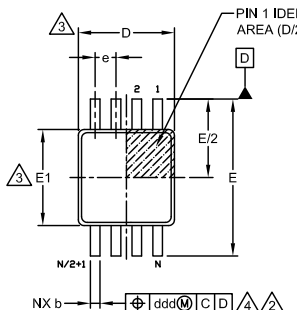

**TOP VIEW**

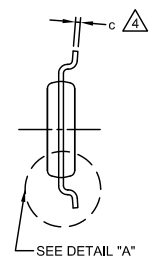

**END VIEW**

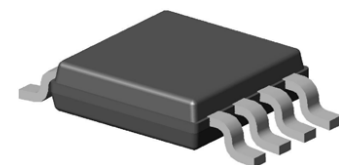

**3-D VIEW**

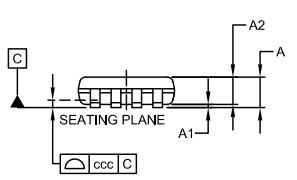

**SIDE VIEW**

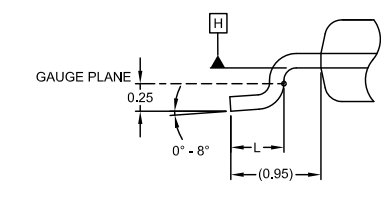

**DETAIL "A"**

REVISION HISTORY			
REV	DESCRIPTION	DATE	RELEASED BY
A	INITIAL RELEASE	7/07/04	S.K.ILIEV
B	REMOVED THE LOGO FROM THE TITLE BLOCK	9/25/07	S.K.ILIEV

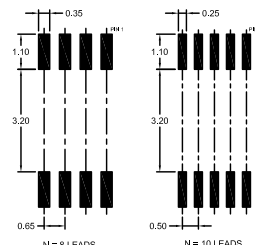
**RECOMMENDED PCB LAND PATTERN**

COMMON DIMENSIONS					
SYMBOL	MIN	NOM	MAX	NOTE	REMARK
A	0.80	-	1.10	-	OVERALL PKG HEIGHT
A1	0.05	-	0.15	-	STANDOFF
A2	0.75	0.85	0.95	-	BODY THICKNESS
D	SEE VARIATIONS			3	"X" BODY SIZE
E	4.65	4.90	5.15	-	LEAD SPAN
E1	2.80	3.00	3.20	3	"Y" BODY SIZE
L	0.40	0.60	0.80	-	LEAD FOOT LENGTH
b	SEE VARIATIONS			2,4	LEAD WIDTH
c	0.08	-	0.23	4	LEAD FOOT THICKNESS
e	SEE VARIATIONS			-	LEAD PITCH
0	-	-	0.10	-	COPLANARITY
ddd	SEE VARIATIONS			-	LEAD TRUE POSITION SPREAD

**NOTES:**

- ALL DIMENSIONS ARE IN MILLIMETER.
- DIMENSION "b" DOES NOT INCLUDE DAMBAR PROTRUSION. DAMBAR CANNOT BE LOCATED ON THE LOWER RADIUS OF THE FOOT.
- DIMENSIONS "D" AND "E1" DO NOT INCLUDE MOLD PROTRUSIONS, FLASH OR INTERLEAD FLASH. MAXIMUM MOLD PROTRUSIONS, FLASH OR INTERLEAD FLASH IS 0.15 mm PER END OR SIDE. "D" AND "E1" ARE DETERMINED AT DATUM PLANE "H" AND INCLUDE ANY MISMATCH BETWEEN THE TOP AND BOTTOM OF THE PLASTIC BODY.
- DIMENSIONS "b" AND "c" APPLY TO THE FLAT SECTION OF THE LEAD BETWEEN 0.08 AND 0.15 mm FROM THE LEAD TIP.
- DETAILS OF PIN 1 IDENTIFIER ARE OPTIONAL, BUT MUST BE LOCATED WITHIN THE ZONE INDICATED.

VAR	D		e	ddd	b	
N	MIN	MAX	BSC	MAX	MIN	MAX
8	2.80	3.20	0.65	0.13	0.22	0.38
10	2.80	3.20	0.50	0.08	0.17	0.27

UNLESS OTHERWISE SPECIFIED DIMENSIONS ARE IN MILLIMETERS AND TOLERANCES ARE:

DECIMAL	ANGULAR
X.X	±0.1°
X.XX	±0.05°
X.XXX	±0.025°

INTERPRET DIM AND TOL PER ASME Y14.5M - 1994

THIRD ANGLE PROJECTION

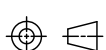

Note: For the most current package drawings, see the Microchip Packaging Specification at <http://www.microchip.com/packaging>

MATERIAL		NAME	DATE	<b>PACKAGE OUTLINE</b> <b>TSSOP FAMILY, 3.0 MM WIDE BODY</b>	
-		DRAWN	7/05/04		
FINISH		CHECKED	7/05/04		
-		APPROVED	7/07/04	DWG NUMBER	
PRINT WITH "SCALE TO FIT" DO NOT SCALE DRAWING		S.K.ILIEV	7/07/04	MO-TSSOP-3.0mm-WIDE	
			SCALE	STD COMPLIANCE	SHEET
			1:1	JEDEC: MO-187	1 OF 1



---

---

## Legacy SMSC Packaging Outlines and Dimensions

---

---

### TQFP

SMSC Legacy

## Legacy SMSC Packaging Outlines and Dimensions

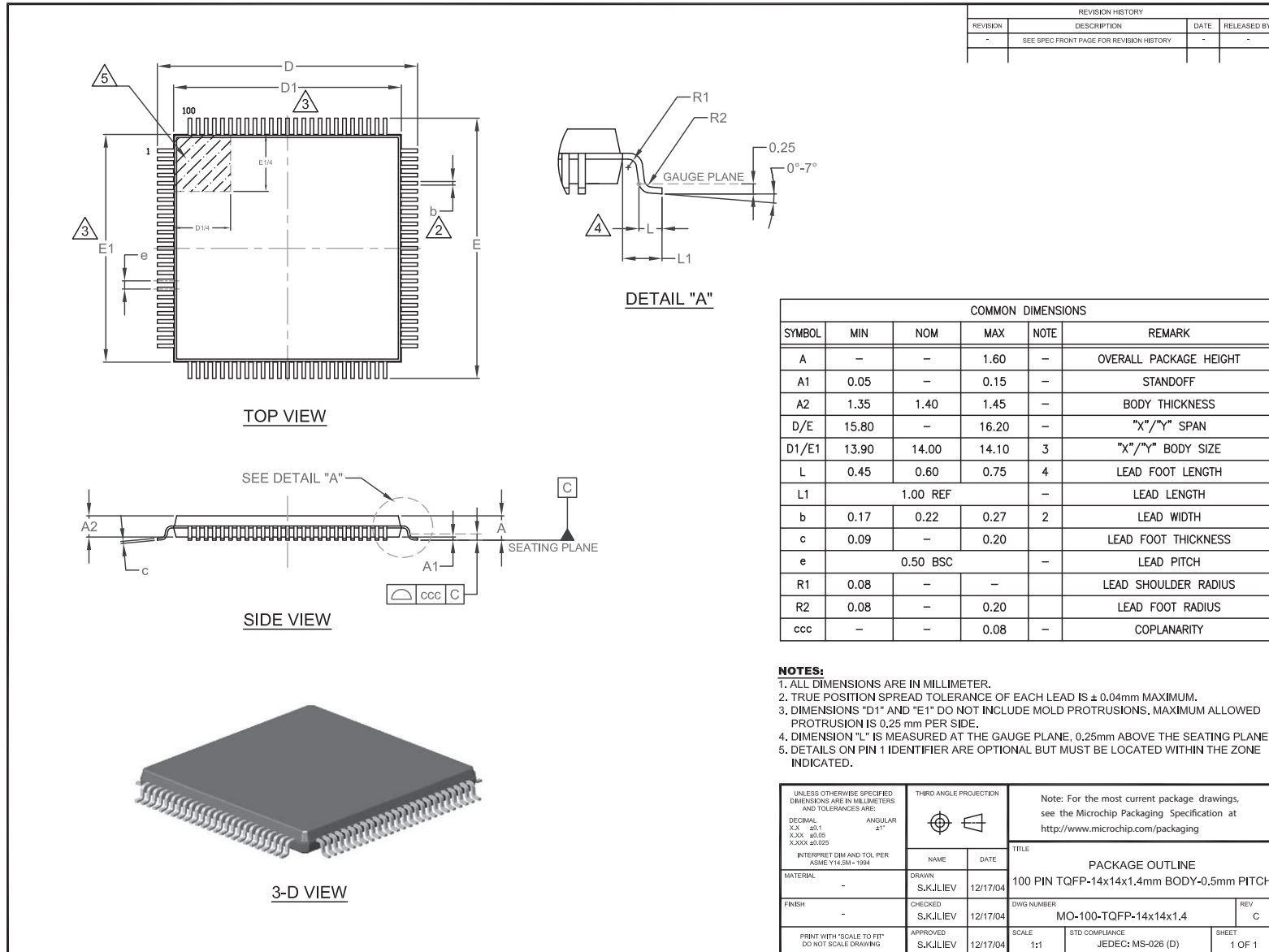

REVISION HISTORY			
REVISION	DESCRIPTION	DATE	RELEASED BY
-	SEE SPEC FRONT PAGE FOR REVISION HISTORY	-	-

## Legacy SMSC Packaging Outlines and Dimensions

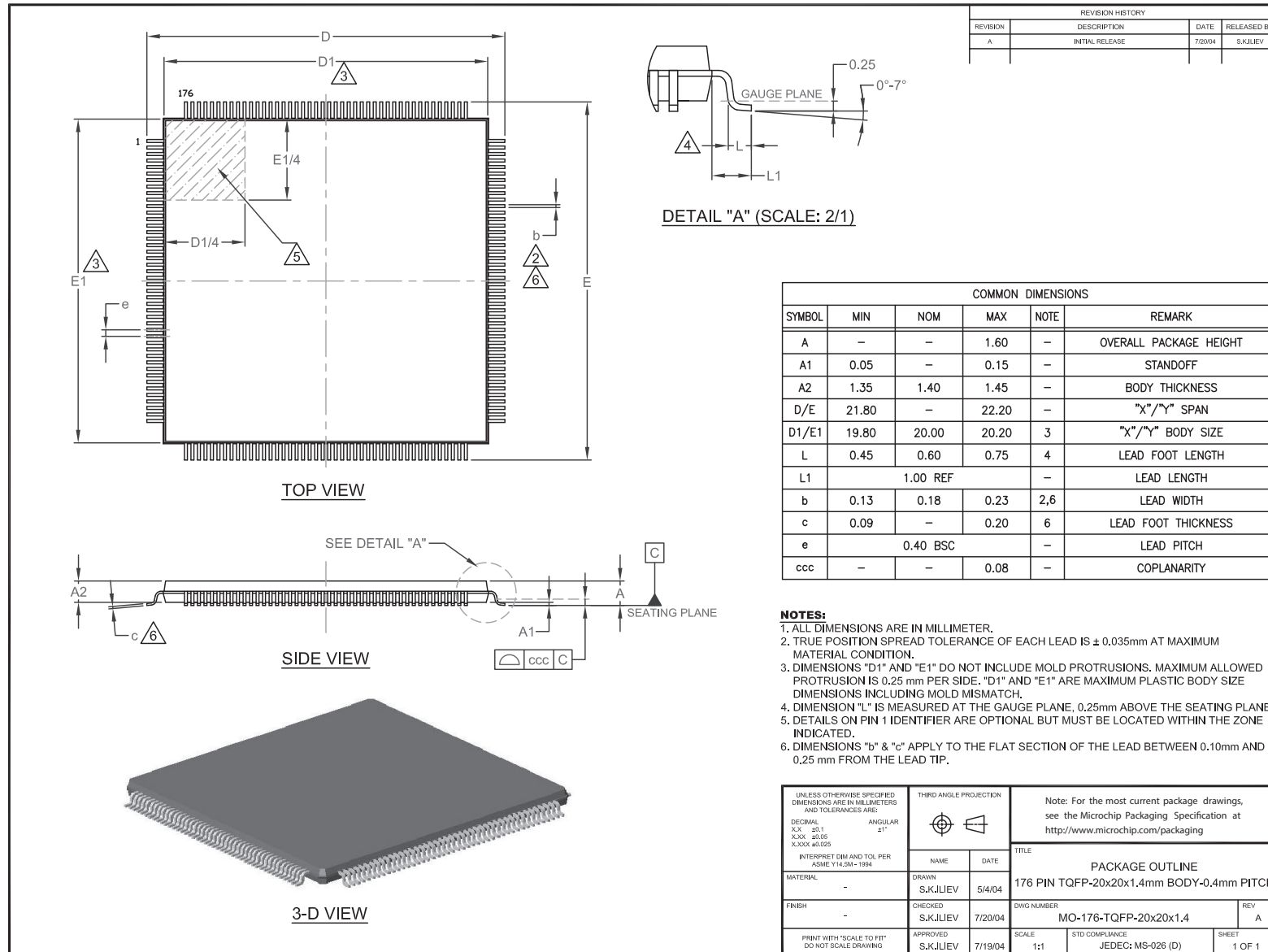

## Legacy SMSC Packaging Outlines and Dimensions

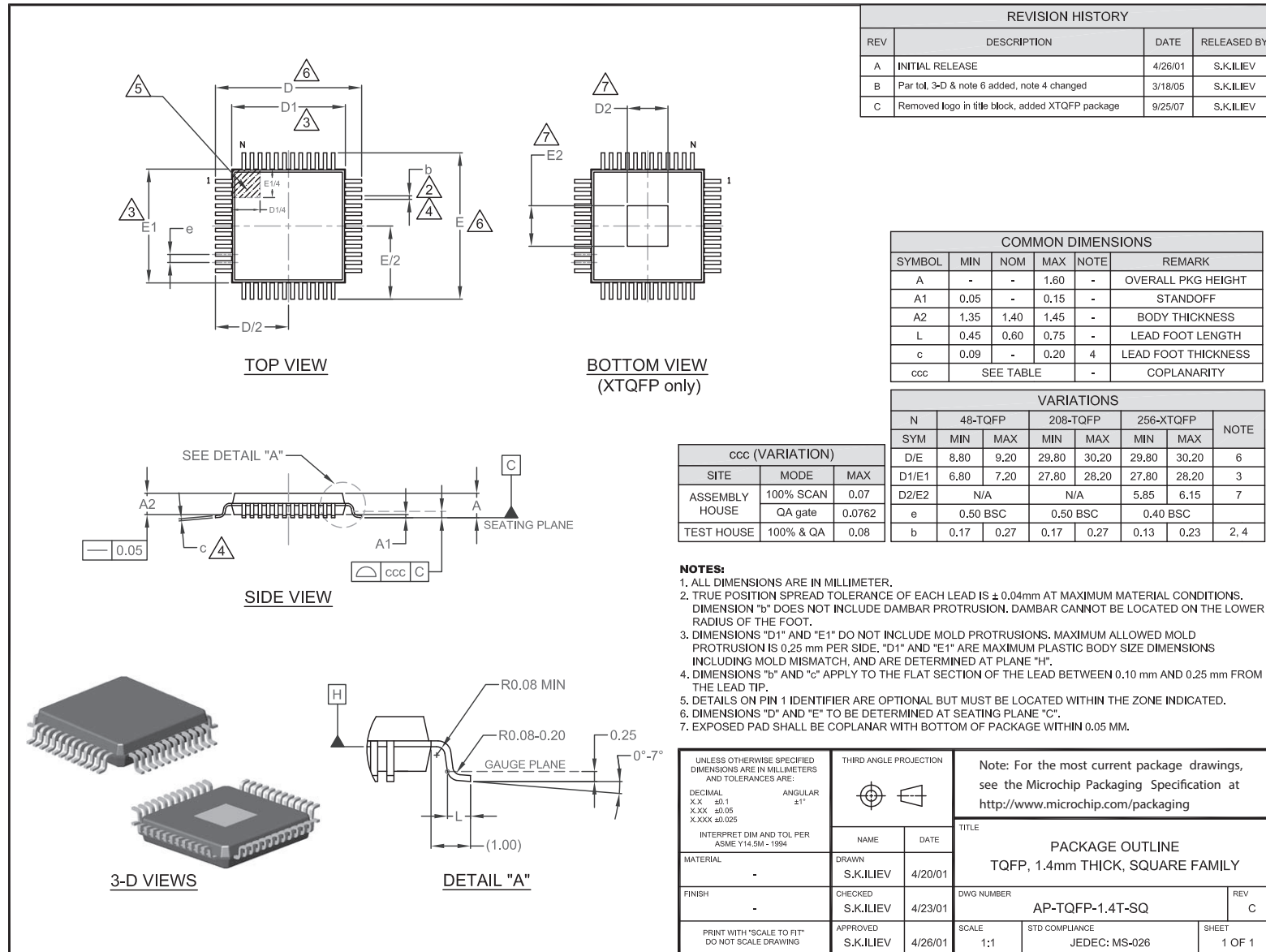

---

---

## Legacy SMSC Packaging Outlines and Dimensions

---

---

### **UFBGA**

SMSC Legacy

## Legacy SMSC Packaging Outlines and Dimensions

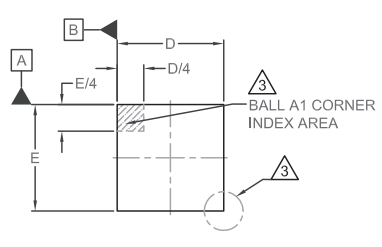

**TOP VIEW**

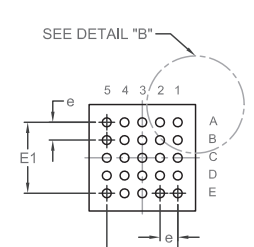

**BOTTOM VIEW**

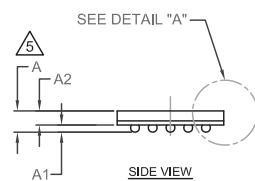

**SIDE VIEW**

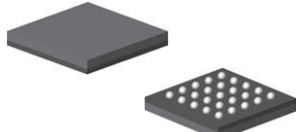

**3-D VIEWS**

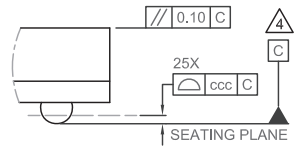

**DETAIL A**

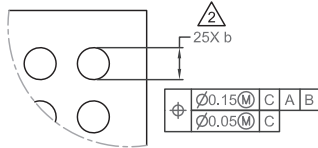

**DETAIL B**

REVISION HISTORY			
REV	DESCRIPTION	DATE	REL. BY
A	INITIAL PRELIMINARY RELEASE	11/7/07	S.K.ILIEV
B	INITIAL RELEASE	3/2/2008	SKI

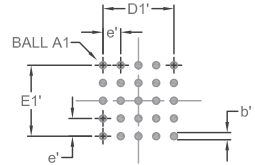
**PCB LAND PATTERN**

LAND PATTERN DIMENSIONS			
SYMBOL	MIN	NOM	MAX
D1'/E1'	-	2.00	-
b'	0.20	-	0.25
e'	-	0.50	-

COMMON DIMENSIONS					
SYMBOL	MIN	NOM	MAX	NOTE	REMARK
A	-	0.61	0.62	5	OVERALL PACKAGE HEIGHT
A1	0.18	0.23	-	-	STANDOFF
A2	0.40 REF			-	PKG BODY THICKNESS
D/E	2.90	3.00	3.10	-	X/Y BODY SIZE
D1/E1	2.00 BSC			-	X/Y END BALLS DISTANCE
b	0.25	0.30	0.35	2	BALL DIAMETER
e	0.50 BSC			-	BALL PITCH
ccc	0	-	0.08	4	COPLANARITY

**NOTES:**

- ALL DIMENSIONS ARE IN MILLIMETERS.
- DIMENSION "b" IS MEASURED AT THE MAXIMUM BALL DIAMETER, PARALLEL TO PRIMARY DATUM "C".
- THE BALL "A1" CORNER MUST BE IDENTIFIED IN THE INDICATED AREA OF THE TOP PACKAGE SURFACE BY USING A CORNER CHAMFER, INK/LASER/METALIZED MARKING, INDENTATION, OR OTHER FEATURE OF PACKAGE BODY. EXACT SHAPE OF EACH CORNER IS OPTIONAL, BUT TERMINAL "A1" CORNER MUST BE UNIQUE.
- PRIMARY DATUM "C" AND SEATING PLANE ARE DEFINED BY THE SPHERICAL CROWNS OF THE CONTACT SOLDER BALLS.
- DIMENSION "A" DOES NOT INCLUDE ATTACHED EXTERNAL FEATURES, SUCH AS HEAT SINK OR CHIP CAPACITORS.

UNLESS OTHERWISE SPECIFIED DIMENSIONS ARE IN MILLIMETERS AND TOLERANCES ARE:

DECIMAL	ANGULAR
XX ±0.1	±1°
XXX ±0.05	
XXXX ±0.025	

INTERPRET DIM AND TOL PER ASME Y14.5M - 1994

MATERIAL	THIRD ANGLE PROJECTION
N/A	
FINISH	NAME      DATE
N/A	S.K.ILIEV    11/7/07
APPROVED	CHECKED
S.K.ILIEV	S.K.ILIEV
11/7/07	11/7/07

Note: For the most current package drawings, see the Microchip Packaging Specification at <http://www.microchip.com/packaging>

TITLE	
PACKAGE OUTLINE	
25 BALL UFBGA, 3x3mm BODY, 0.50mm PITCH	
DWG NUMBER	REV
AP-25UFBGA-3x3B-0.5P	B
SCALE	STD COMPLIANCE
1:1	MO-280
SHEET	1 OF 1

---

---

## Legacy SMSC Packaging Outlines and Dimensions

---

---

### **VFBGA**

SMSC Legacy

## Legacy SMSC Packaging Outlines and Dimensions

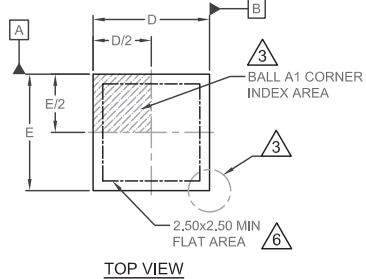

**TOP VIEW**

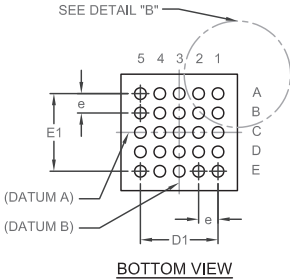

**BOTTOM VIEW**

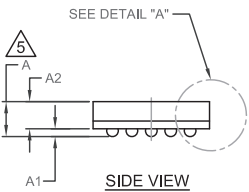

**SIDE VIEW**

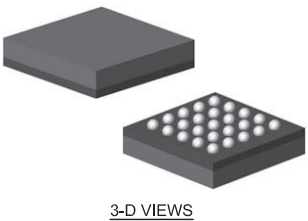

**3-D VIEWS**

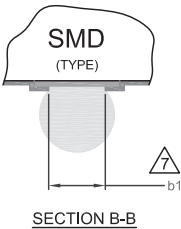

**SECTION B-B**

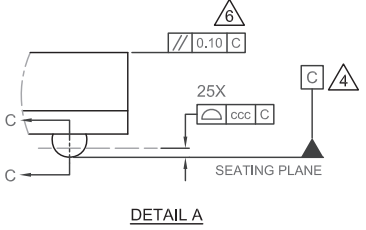

**DETAIL A**

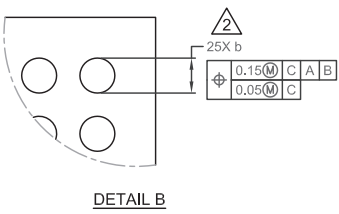

**DETAIL B**

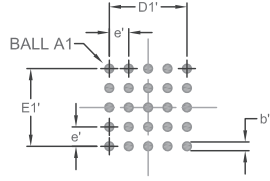

**PCB LAND PATTERN**

THE USER MAY MODIFY THE PCB LAND PATTERN DIMENSIONS BASED ON THEIR EXPERIENCE AND/OR PROCESS CAPABILITY

REVISION HISTORY			
REV	DESCRIPTION	DATE	REL. BY
A	INITIAL RELEASE	6/8/06	S.K.ILIEV
B	ADDED b1, Amin, Amax and A2max. Updated PCB dimensions accordingly.	April-2010	S.K.ILIEV

COMMON DIMENSIONS					
SYMBOL	MIN	NOM	MAX	NOTE	REMARK
A	0.77	-	1.00	5	OVERALL PACKAGE HEIGHT
A1	0.15	-	0.29	-	STANDOFF
A2	0.65	-	0.71	-	PKG BODY THICKNESS
D/E	2.90	3.00	3.10	-	X/Y BODY SIZE
D1/E1	2.00 BSC			-	X/Y END BALLS DISTANCE
b	0.25	0.30	0.35	2	BALL DIAMETER
b1	0.22	0.25	0.28	7	SOLDERABLE SURFACE
e	0.50 BSC			-	BALL PITCH
ccc	0	-	0.08	4	COPLANARITY

**NOTES:**

1. ALL DIMENSIONS ARE IN MILLIMETERS.
2. DIMENSION "b" IS MEASURED AT THE MAXIMUM BALL DIAMETER, PARALLEL TO PRIMARY DATUM "C".
3. THE BALL "A1" CORNER MUST BE IDENTIFIED IN THE INDICATED AREA OF THE TOP PACKAGE SURFACE BY USING A CORNER CHAMFER, INK/LASER/METALIZED MARKING, INDENTATION, OR OTHER FEATURE OF PACKAGE BODY. EXACT SHAPE OF EACH CORNER IS OPTIONAL, BUT TERMINAL "A1" CORNER MUST BE UNIQUE.
4. PRIMARY DATUM "C" AND SEATING PLANE ARE DEFINED BY THE SPHERICAL CROWNS OF THE CONTACT SOLDER BALLS.
5. DIMENSION "A" DOES NOT INCLUDE ATTACHED EXTERNAL FEATURES, SUCH AS HEAT SINK OR CHIP CAPACITORS.
6. PARALLELISM ON THE TOP SURFACE APPLIES ONLY TO THE MINIMUM FLAT AREA SHOWN ON THE TOP VIEW.
7. THE PACKAGE BALL SOLDERABLE SURFACE IS SOLDER-MASK-DEFINED (SMD).

LAND PATTERN DIMENSIONS	
SYMBOL	MIN NOM MAX
D1'/E1'	2.00 BSC
b'	0.25 0.25 0.28
e'	0.50 BSC

UNLESS OTHERWISE SPECIFIED DIMENSIONS ARE IN MILLIMETERS AND TOLERANCES ARE: DECIMAL X.X ±0.1 X.XX ±0.05 X.XXX ±0.025	ANGULAR ±1°		Note: For the most current package drawings, see the Microchip Packaging Specification at <a href="http://www.microchip.com/packaging">http://www.microchip.com/packaging</a>
INTERPRET DIM AND TOL PER ASME Y14.5M - 1994		NAME DATE	TITLE <b>PACKAGE OUTLINE</b> <b>25 BALL VFBGA, 3x3mm BODY, 0.50mm PITCH</b>
MATERIAL N/A	DRAWN -	DATE 6/8/06	DWG NUMBER <b>25VFBGA-3x3B-0.5P</b>
FINISH N/A	CHECKED S.K.ILIEV	DATE 6/8/06	REV <b>B</b>
PRINT WITH "SCALE TO FIT" DO NOT SCALE DRAWING	APPROVED S.K.ILIEV	DATE 6/8/06	SCALE 1:1
STD COMPLIANCE -		SHEET 1 OF 1	

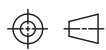

## Legacy SMSC Packaging Outlines and Dimensions



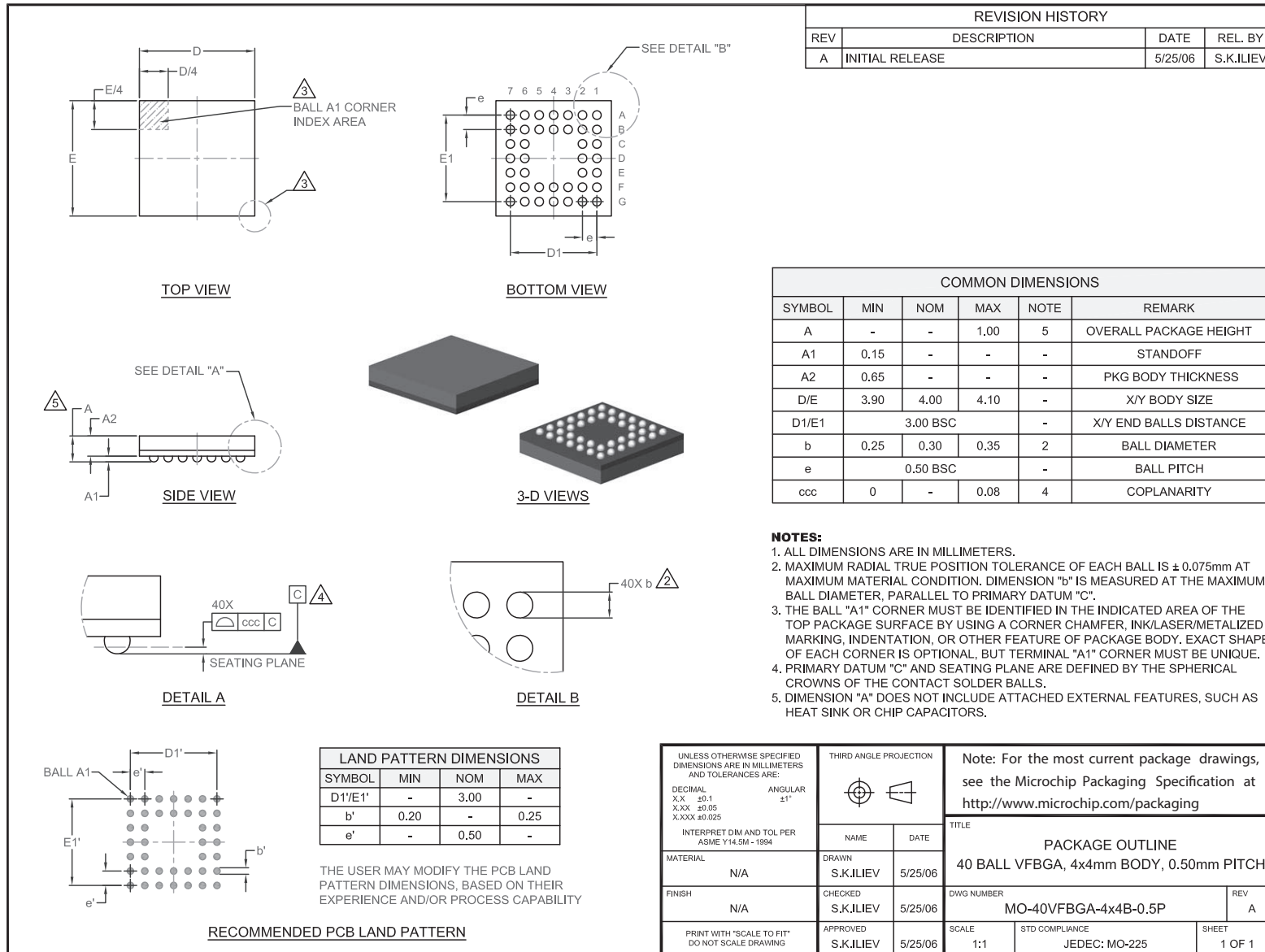

**MICROCHIP**

---

---

**Legacy SMSC Packaging Outlines and Dimensions**

---

---

**NOTES:**

---

---

**Legacy SMSC Packaging Outlines and Dimensions**

---

---

**WFBGA**

SMSC Legacy

## Legacy SMSC Packaging Outlines and Dimensions

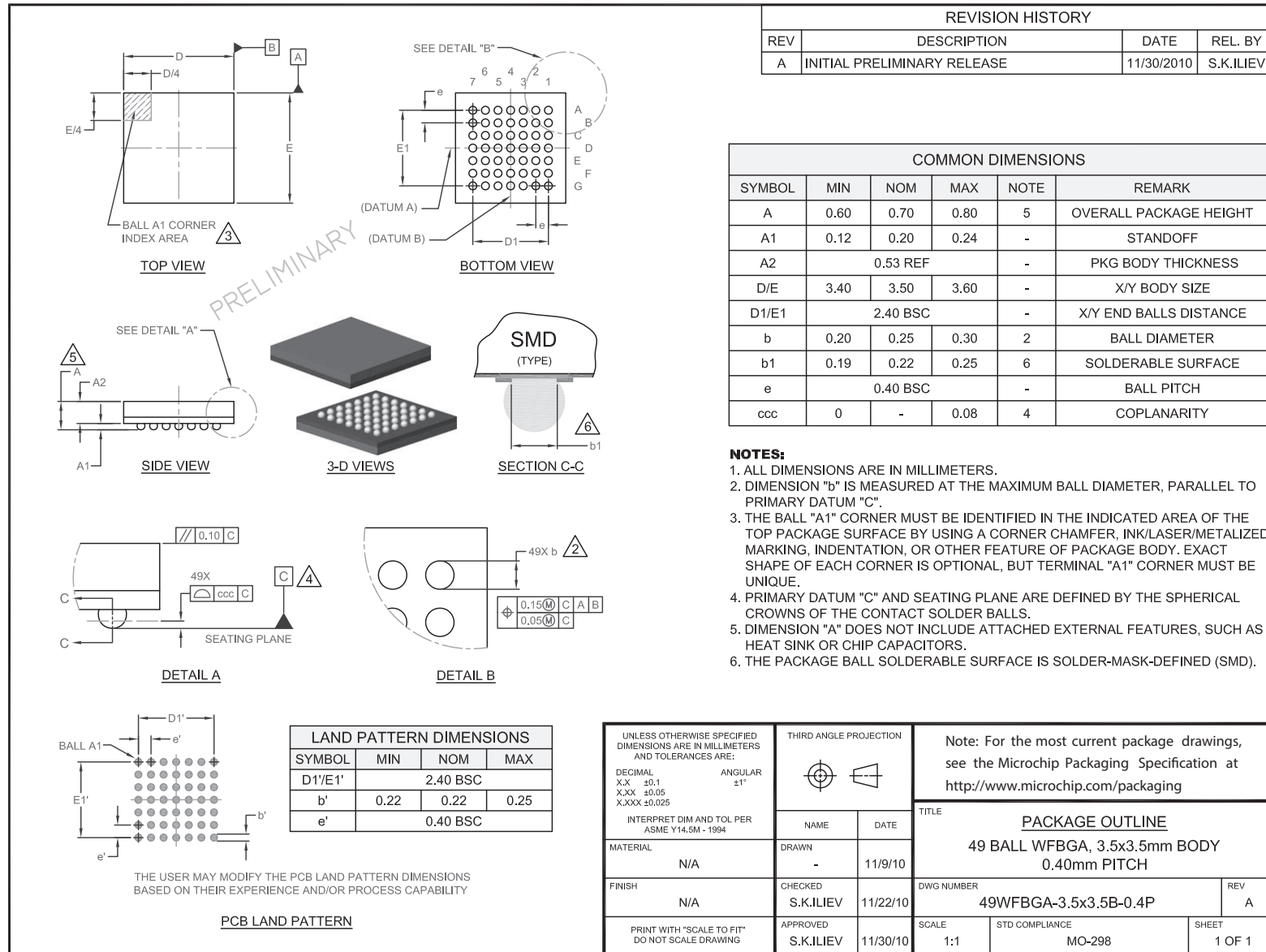

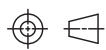
<p>UNLESS OTHERWISE SPECIFIED DIMENSIONS ARE IN MILLIMETERS AND TOLERANCES ARE:</p> <p>DECIMAL                      ANGULAR</p> <p>X.X                              ±0.1</p> <p>X.XX                             ±0.05</p> <p>X.XXX                            ±0.025</p> <p>INTERPRET DIM AND TOL PER ASME Y14.5M - 1994</p>	<p>THIRD ANGLE PROJECTION</p> 	<p>Note: For the most current package drawings, see the Microchip Packaging Specification at <a href="http://www.microchip.com/packaging">http://www.microchip.com/packaging</a></p> <p>TITLE</p> <p style="text-align: center;"><b>PACKAGE OUTLINE</b></p> <p style="text-align: center;"><b>49 BALL WFBGA, 3.5x3.5mm BODY</b></p> <p style="text-align: center;"><b>0.40mm PITCH</b></p>
<p>MATERIAL</p> <p style="text-align: center;">N/A</p>	<p>NAME</p> <p style="text-align: center;">-</p>	<p>DATE</p> <p style="text-align: center;">11/9/10</p>
<p>FINISH</p> <p style="text-align: center;">N/A</p>	<p>CHECKED</p> <p style="text-align: center;">S.K.ILIEV</p>	<p>DATE</p> <p style="text-align: center;">11/22/10</p>
<p>PRINT WITH "SCALE TO FIT" DO NOT SCALE DRAWING</p>	<p>APPROVED</p> <p style="text-align: center;">S.K.ILIEV</p>	<p>DATE</p> <p style="text-align: center;">11/30/10</p>
<p>SCALE</p> <p style="text-align: center;">1:1</p>		<p>STD COMPLIANCE</p> <p style="text-align: center;">MO-298</p>
<p>SHEET</p> <p style="text-align: center;">1 OF 1</p>		<p>DWG NUMBER</p> <p style="text-align: center;">49WFBGA-3.5x3.5B-0.4P</p>
<p>REV</p> <p style="text-align: center;">A</p>		<p>REV</p> <p style="text-align: center;">A</p>

---

---

**Legacy SMSC Packaging Outlines and Dimensions**

---

---

**VTQFP**

SMSC Legacy

## Legacy SMSC Packaging Outlines and Dimensions

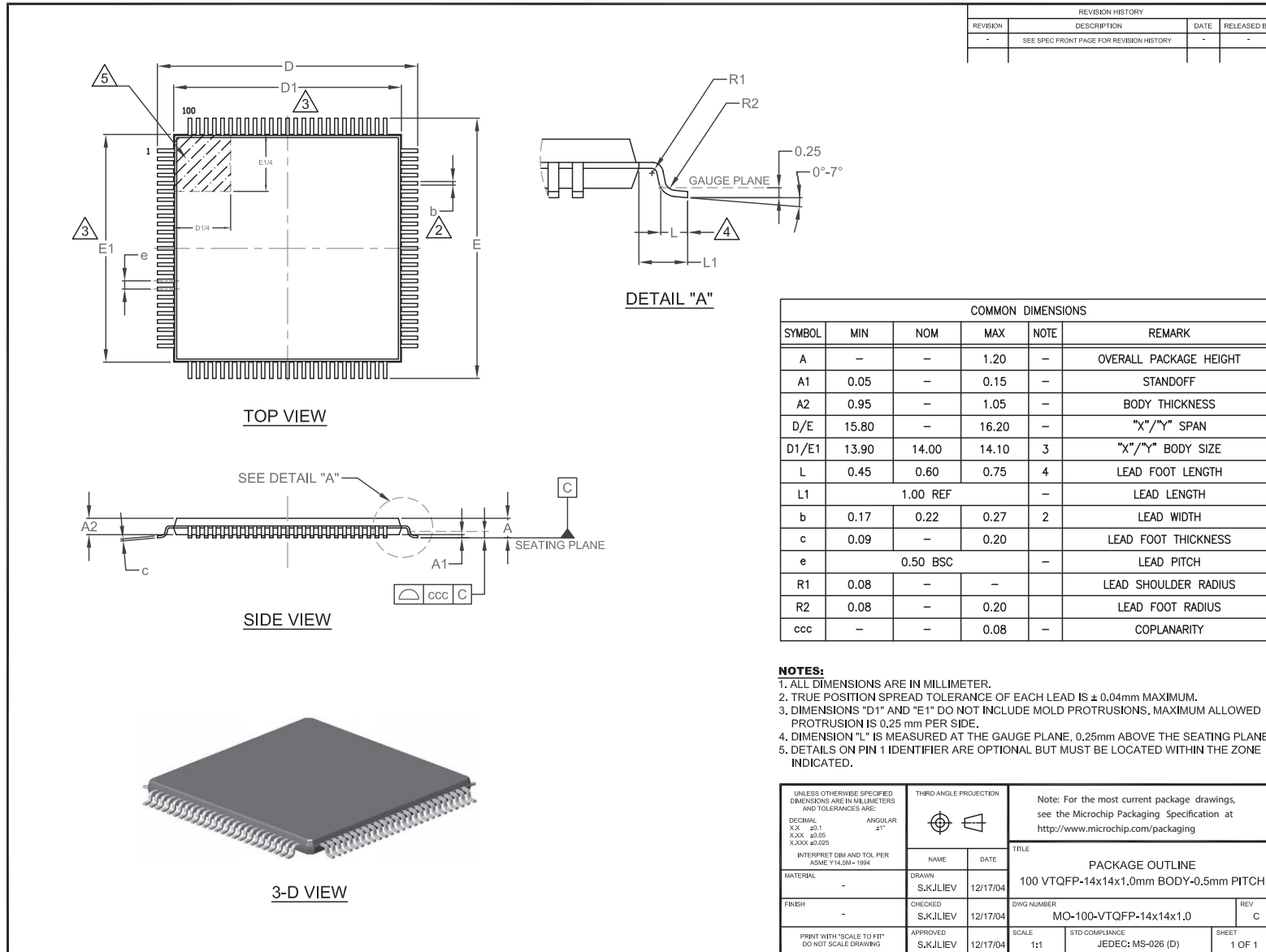

## Legacy SMSC Packaging Outlines and Dimensions

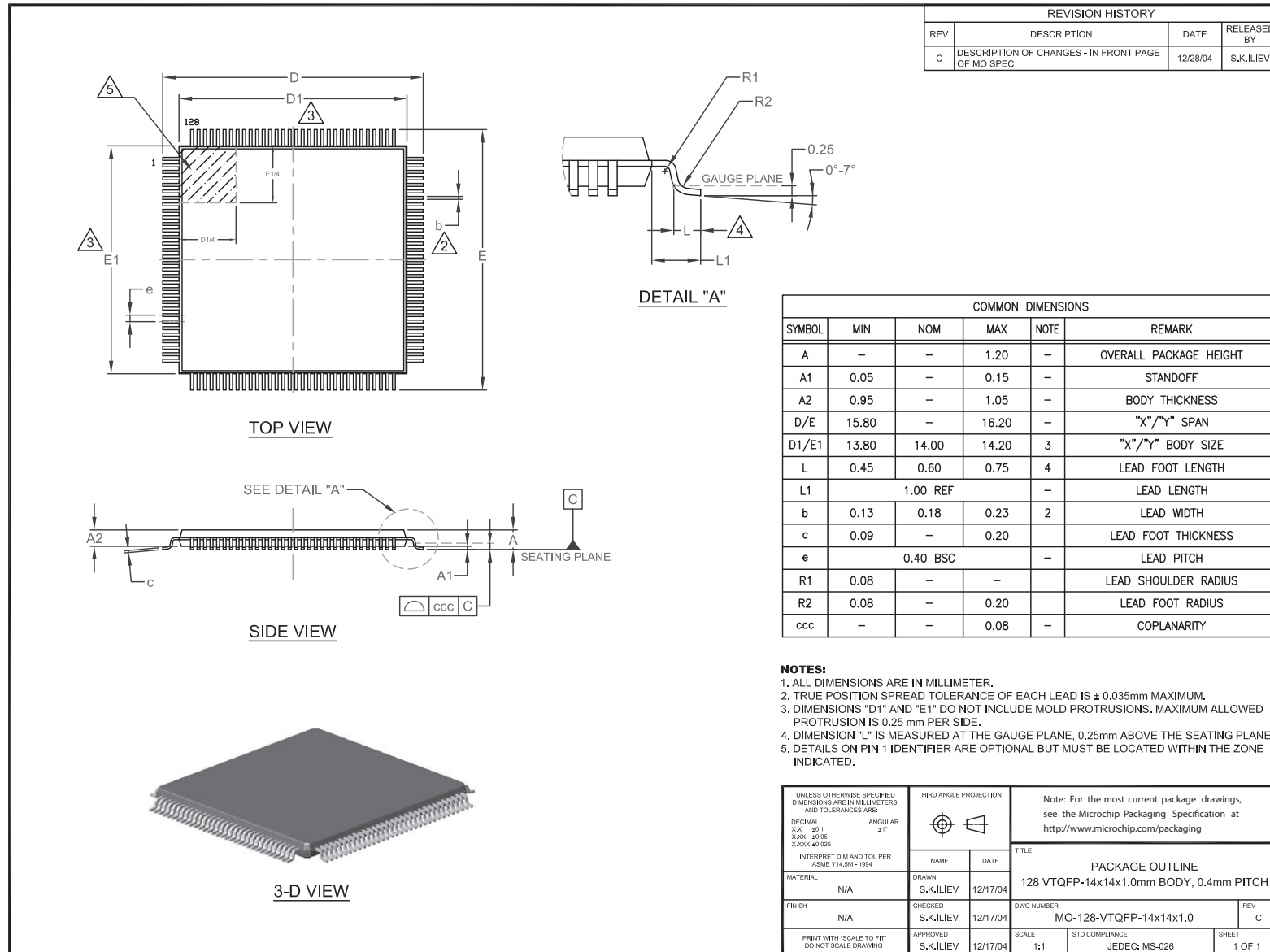

## Legacy SMSC Packaging Outlines and Dimensions

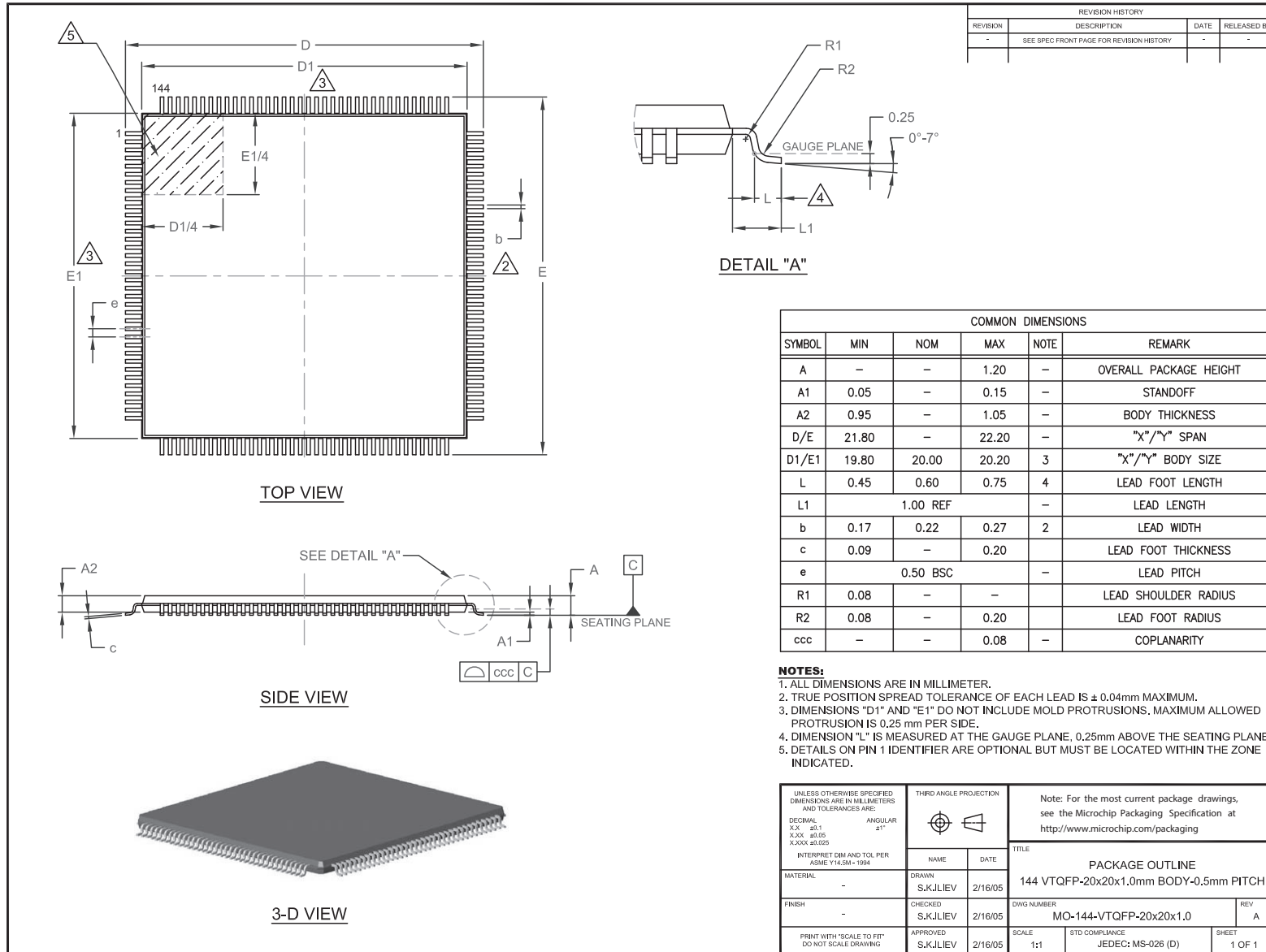



---

---

## Legacy SMSC Packaging Outlines and Dimensions

---

---

**XVTQFP**  
SMSC Legacy

**Legacy SMSC Packaging Outlines and Dimensions**

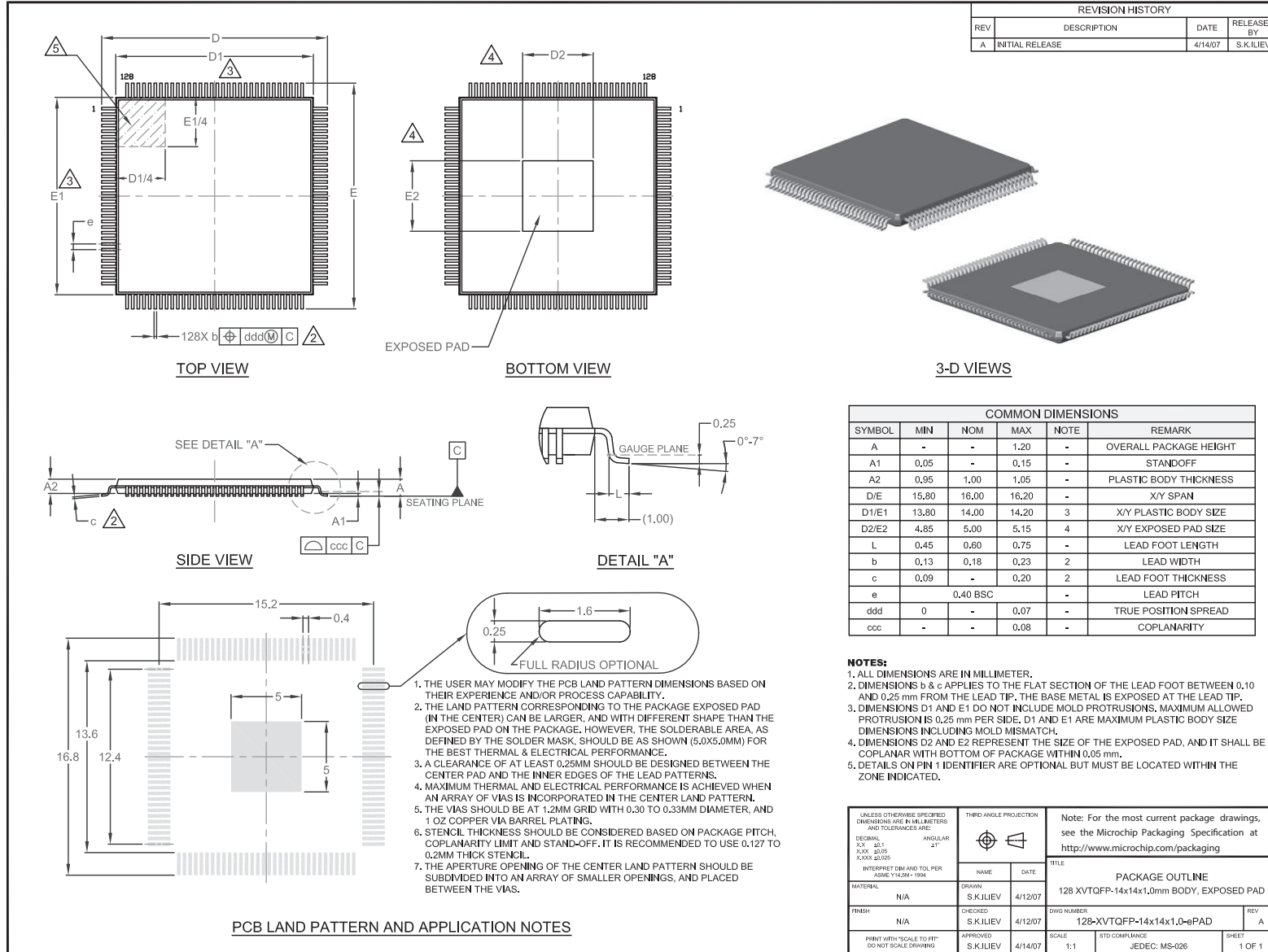

---

---

**Package Outlines and Dimensions**

---

---

**Legacy Supertex Package Drawings & Specifications**



**MICROCHIP**

---

---

**Package Outlines and Dimensions**

---

---

**NOTES:**

---

---

**Package Outlines and Dimensions**

---

---

**BCC**

Supertex Legacy

## Package Outlines and Dimensions

### 26-Lead BCC Package Outline (B1)

6.00x6.00mm body, 0.80mm height (max), 0.65mm pitch

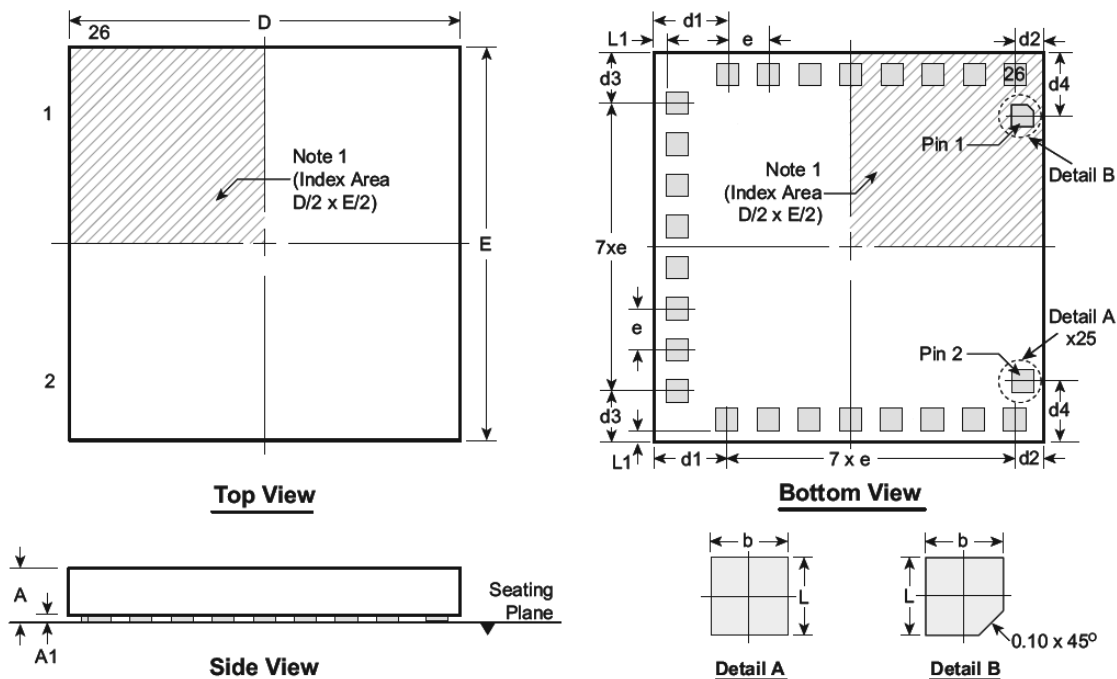

Note: For the most current package drawings, see the Microchip Packaging Specification at [www.microchip.com/packaging](http://www.microchip.com/packaging).

**Notes:**

1. A Pin 1 identifier must be located in the index area indicated. The Pin 1 identifier can be: a molded mark/identifier, an embedded metal marker, or a printed indicator.

Symbol	A	A1	b	D	d1	d2	d3	d4	E	e	L	L1
Dimension (mm)	MIN	0.65	0.050	0.25	5.85	1.050	0.400	0.725	0.925	5.85	0.25	0.10
	NOM	-	0.075	0.35	6.00	REF	REF	REF	REF	6.00	0.35	REF
	MAX	0.80	0.100	0.45	6.15					6.15	0.45	

Drawings not to scale.

---



---

## Package Outlines and Dimensions

---



---

### 84-Lead BCC+ Package Outline (B2)

7.00x7.00mm body, 0.80mm height (max), 0.50mm pitch

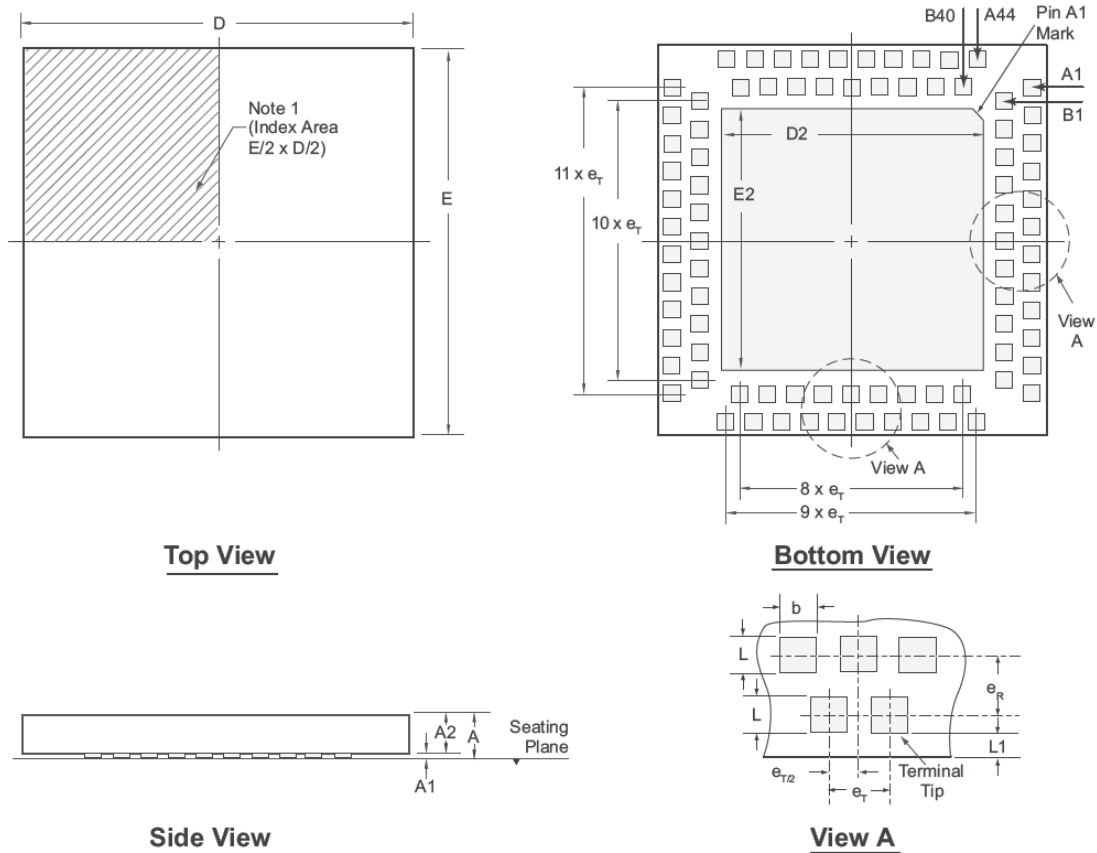

Note: For the most current package drawings, see the Microchip Packaging Specification at [www.microchip.com/packaging](http://www.microchip.com/packaging).

**Note:**

1. A Pin 1 identifier must be located in the index area indicated. The Pin 1 identifier can be: a molded mark/identifier; an embedded metal marker; or a printed indicator.

Symbol	A	A1	A2	b	D	D2	E	E2	$e_R$	$e_T$	L	L1
Dimension (mm)	MIN	0.65	0.05	0.60	0.20	6.85	4.55	6.85	0.50	0.50	0.20	0.10 REF
	NOM	-	-	0.65	0.30	7.00	4.70	7.00	BSC	BSC	0.30	
	MAX	0.80	0.10	0.70	0.40	7.15	4.85	7.15			0.40	

Drawings not to scale.



**MICROCHIP**

---

---

**Package Outlines and Dimensions**

---

---

**NOTES:**



---

---

**Package Outlines and Dimensions**

---

---

**BD**

Supertex Legacy

## Package Outlines and Dimensions

### 42-Ball Bumped Die Package Outline (BD)

5.29x5.30mm body, 1.02mm height (max), 0.52 / 0.60mm pitch

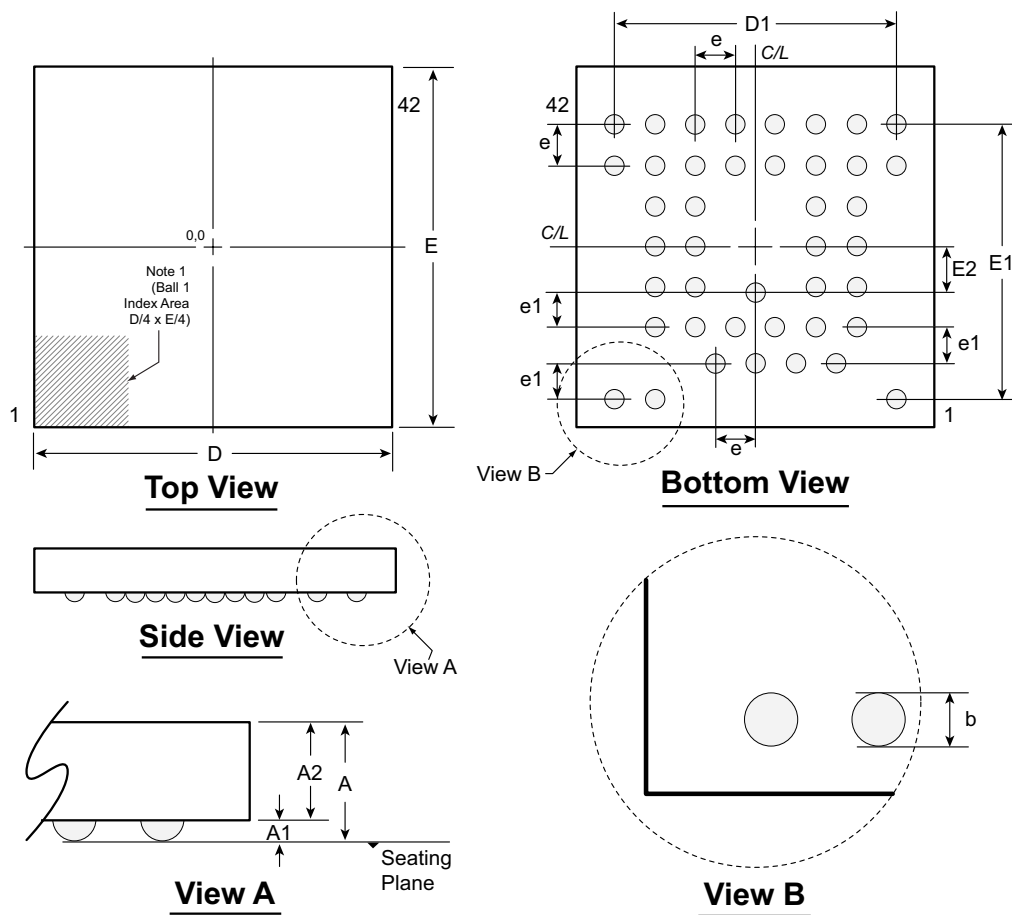

**Notes:** For the most current package drawings, See the Microchip Packaging Specification at [www.microchip.com/packaging](http://www.microchip.com/packaging).

**Notes:**

- Ball 1 identifier must be located in the index area indicated. Ball 1 identifier can be: a molded mark/identifier; an embedded metal marker; or a printed indicator.

Symbol	A	A1	A2	b	D	D1	E	E1	E2	e	e1	
Dimension (mm)	MIN	0.91	0.21	0.70	0.29	5.19	4.20 BSC	5.20	4.04 BSC	0.68 BSC	0.60 BSC	0.52 BSC
	NOM	0.965	0.24	0.725	0.32	5.29		5.30				
	MAX	1.02	0.27	0.75	0.35	5.39		5.40				

---

---

**Package Outlines and Dimensions**

---

---

**Cerpac**

Supertex Legacy

**Package Outlines and Dimensions**

**44-Lead Quad Cerpac Package Outline (DJ)**  
**.650x.650in body, .190in height (max), .050in pitch**

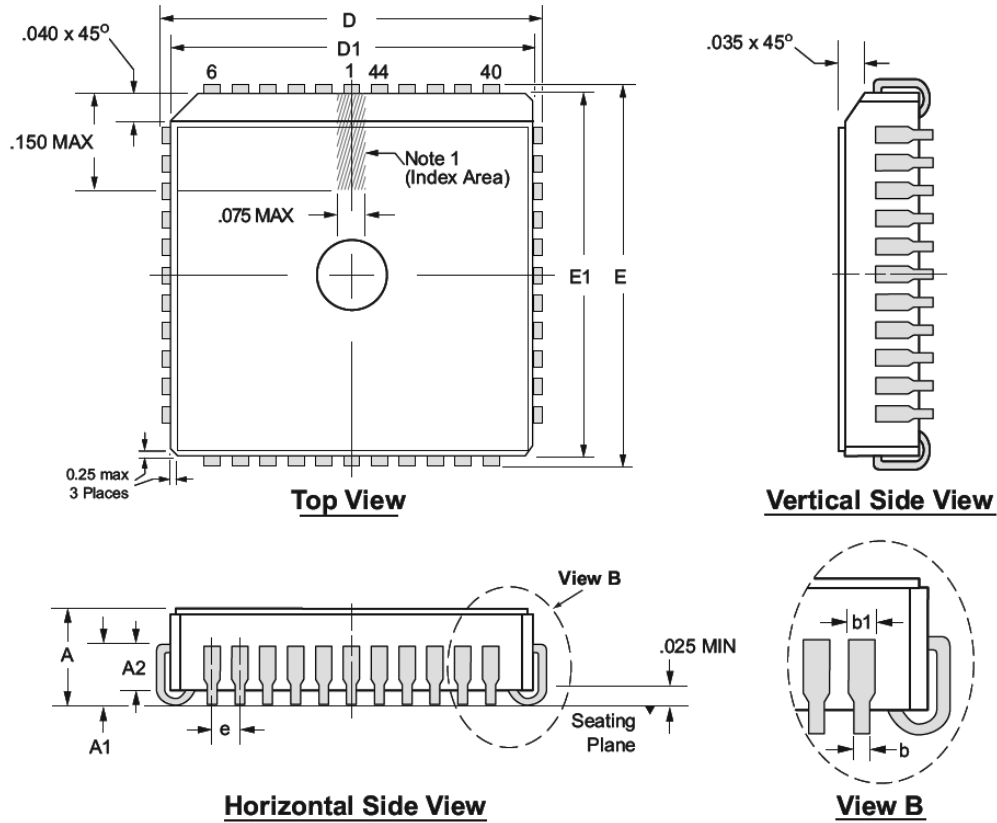

Note: For the most current package drawings, see the Microchip Packaging Specification at [www.microchip.com/packaging](http://www.microchip.com/packaging).

**Note:**

1. A Pin 1 identifier must be located in the index area indicated. The Pin 1 identifier can be: a molded mark/identifier, an embedded metal marker, or a printed indicator.

Symbol	A	A1	A2	b	b1	D	D1	E	E1	e	
Dimension (inches)	MIN	.155	.090	.060 REF	.017	.026	.685	.630	.685	.630	.050 BSC
	NOM	.172	.100		.019	.029	.690	.650	.690	.650	
	MAX	.190	.120		.021	.032	.695	.665	.695	.665	

JEDEC Registration MO-087, Variation AB, Issue B, August, 1991.  
 Drawings not to scale.

---

---

**Package Outlines and Dimensions**

---

---

**DFN**

Supertex Legacy

**Package Outlines and Dimensions**

**10-Lead DFN Package Outline (K7)**

3.00x3.00mm body, 0.80mm height (max), 0.50mm pitch

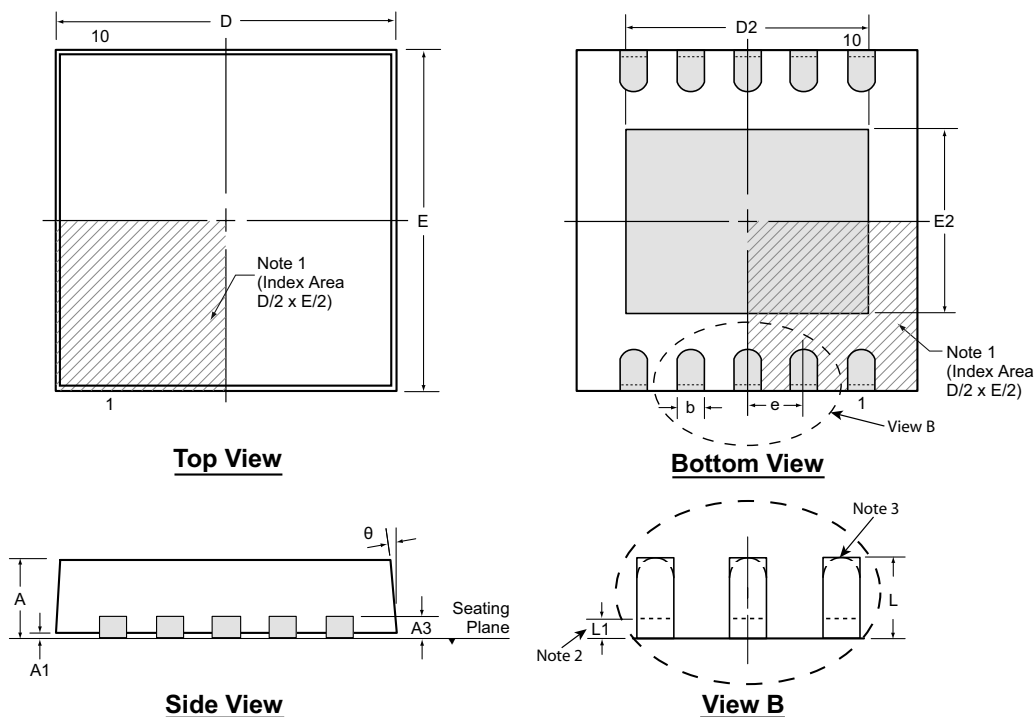

Note: For the most current package drawings, see the Microchip Packaging Specification at [www.microchip.com/packaging](http://www.microchip.com/packaging).

**Notes:**

1. A Pin 1 identifier must be located in the index area indicated. The Pin 1 identifier can be: a molded mark/identifier; an embedded metal marker; or a printed indicator.
2. Depending on the method of manufacturing, a maximum of 0.15mm pullback (L1) may be present.
3. The inner tip of the lead may be either rounded or square.

Symbol	A	A1	A3	b	D	D2	E	E2	e	L	L1	θ	
Dimension (mm)	MIN	0.70	0.00	0.20 REF	0.18	2.85*	2.20	2.85*	1.40	0.50 BSC	0.30	0.00*	0°
	NOM	0.75	0.02		0.25	3.00	-	3.00	-		0.40	-	-
	MAX	0.80	0.05		0.30	3.15*	2.70	3.15*	1.75		0.50	0.15	14°

JEDEC Registration MO-229, Variation WEED-5, Issue C, Aug. 2003.

\* This dimension is not specified in the JEDEC drawing.

Drawings not to scale.

---



---

## Package Outlines and Dimensions

---



---

### 19-Lead DFN Package Outline (K7)

7.00x5.00mm body, 0.80mm height (max), 0.50mm pitch

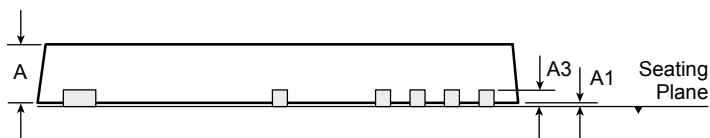
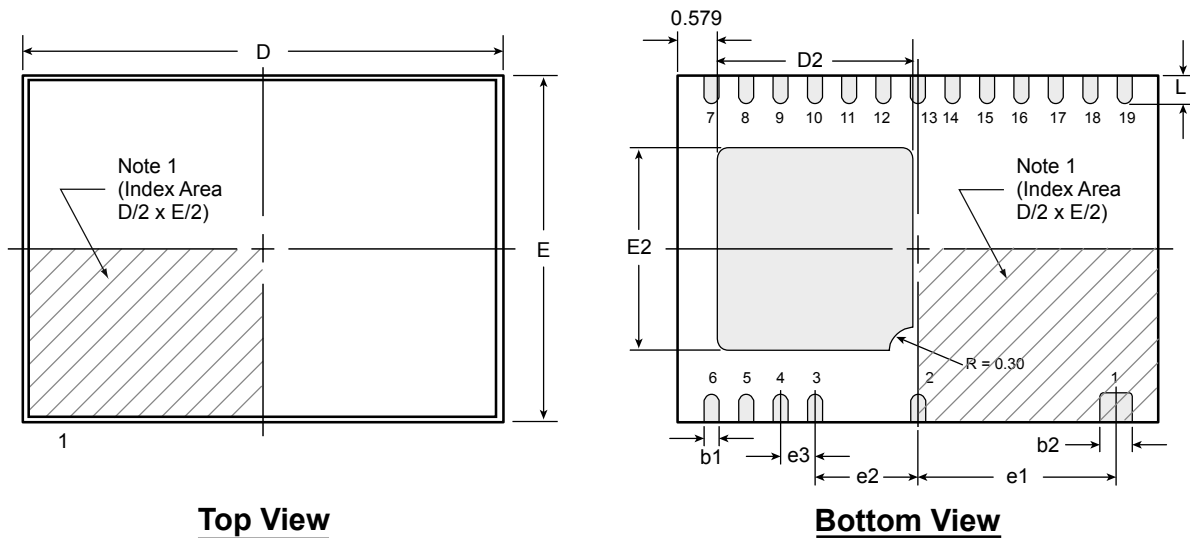

**Side View**

**Note:** For the most current package drawings, see the Microchip Packaging Specification at [www.microchip.com/packaging](http://www.microchip.com/packaging).

**Notes:**

1. A Pin 1 identifier must be located in the index area indicated. The Pin 1 identifier can be: a molded mark/identifier; an embedded metal marker; or a printed indicator.
2. Depending on the method of manufacturing, a maximum of 0.15mm pullback (L1) may be present.
3. The inner tip of the lead may be either rounded or square.

Symbol	A	A1	A3	b1	b2	D	D2	E	E2	e1	e2	e3	L	
Dimension (mm)	MIN	0.70	0.00	0.20 REF	0.20	0.42	7.00 BSC	2.692	5.00 BSC	2.802	2.875 BSC	1.50 BSC	0.50 BSC	0.30
	NOM	0.75	0.02		0.25	0.47		2.842		2.952				0.40
	MAX	0.80	0.05		0.30	0.52		2.942		3.052				0.50

*Drawings not to scale.*

**Package Outlines and Dimensions**

**8-Lead DFN Package Outline (K6)**

**4.00x4.00mm body, 1.00mm height (max), 1.00mm pitch (dual pad)**

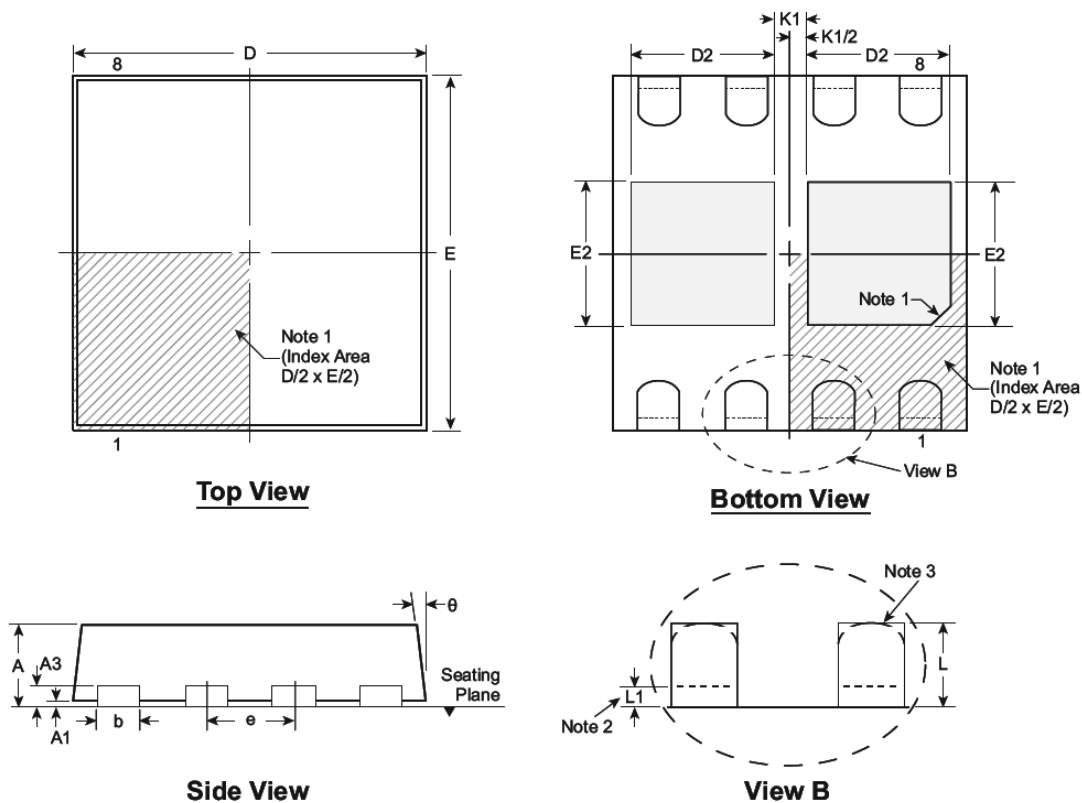

Note: For the most current package drawings, see the Microchip Packaging Specification at [www.microchip.com/packaging](http://www.microchip.com/packaging).

**Notes:**

1. A Pin 1 identifier must be located in the index area indicated. The Pin 1 identifier can be: a molded mark/identifier; an embedded metal marker; or a printed indicator.
2. Depending on the method of manufacturing, a maximum of 0.15mm pullback (L1) may be present.
3. The inner tip of the lead may be either rounded or square.

Symbol	A	A1	A3	b	D	D2	E	E2	e	K1	L	L1	θ	
Dimension (mm)	MIN	0.80	0.00	0.20 REF	0.25	3.90	1.35	3.90	1.35	1.00 BSC	0.50 REF	0.40	0.00	0°
	NOM	0.90	-		0.30	4.00	1.45	4.00	1.45			0.50	-	-
	MAX	1.00	0.05		0.35	4.10	1.55	4.10	1.55			0.60	0.15	14°

Drawings not to scale



---



---

## Package Outlines and Dimensions

---



---

### 8-Lead DFN Package Outline (K6)

5.00x5.00mm body, 0.90mm height (max), 1.27mm pitch (dual pad)

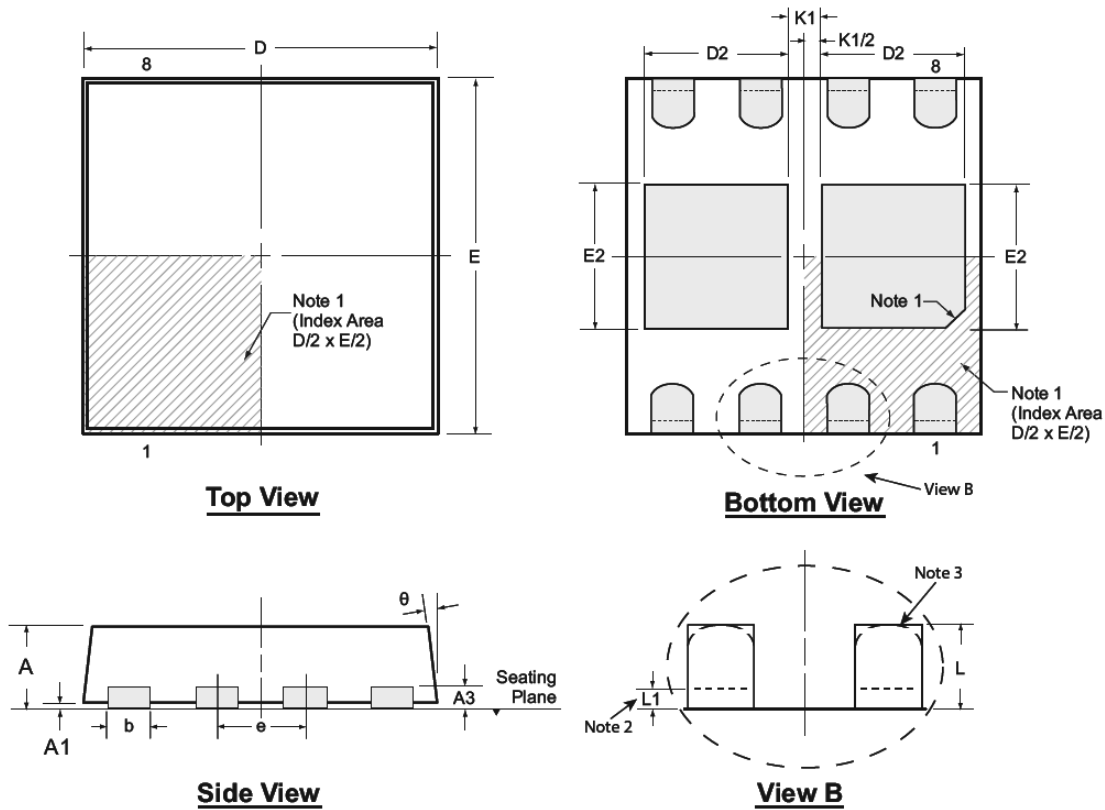

Note: For the most current package drawings, see the Microchip Packaging Specification at [www.microchip.com/packaging](http://www.microchip.com/packaging).

**Notes:**

1. A Pin 1 identifier must be located in the index area indicated. The Pin 1 identifier can be: a molded mark/identifier; an embedded metal marker; or a printed indicator.
2. Depending on the method of manufacturing, a maximum of 0.15mm pullback (L1) may be present.
3. The inner tip of the lead may be either rounded or square.

Symbol	A	A1	A3	b	D	D2	E	E2	e	K1	L	L1	$\theta$	
Dimension (mm)	MIN	0.80	0.00	0.20 REF	0.35	4.90	1.93	4.90	1.90	1.27 BSC	0.40 REF	0.40	0.00	0°
	NOM	0.85	-		0.40	5.00	2.03	5.00	2.00			0.50	-	-
	MAX	0.90	0.05		0.45	5.10	2.13	5.10	2.10			0.60	0.15	14°

Drawings not to scale

**Package Outlines and Dimensions**

**10-Lead DFN Package Outline (K6)**

*3.00x4.00mm body, 1.00mm height (max), 0.50mm pitch*

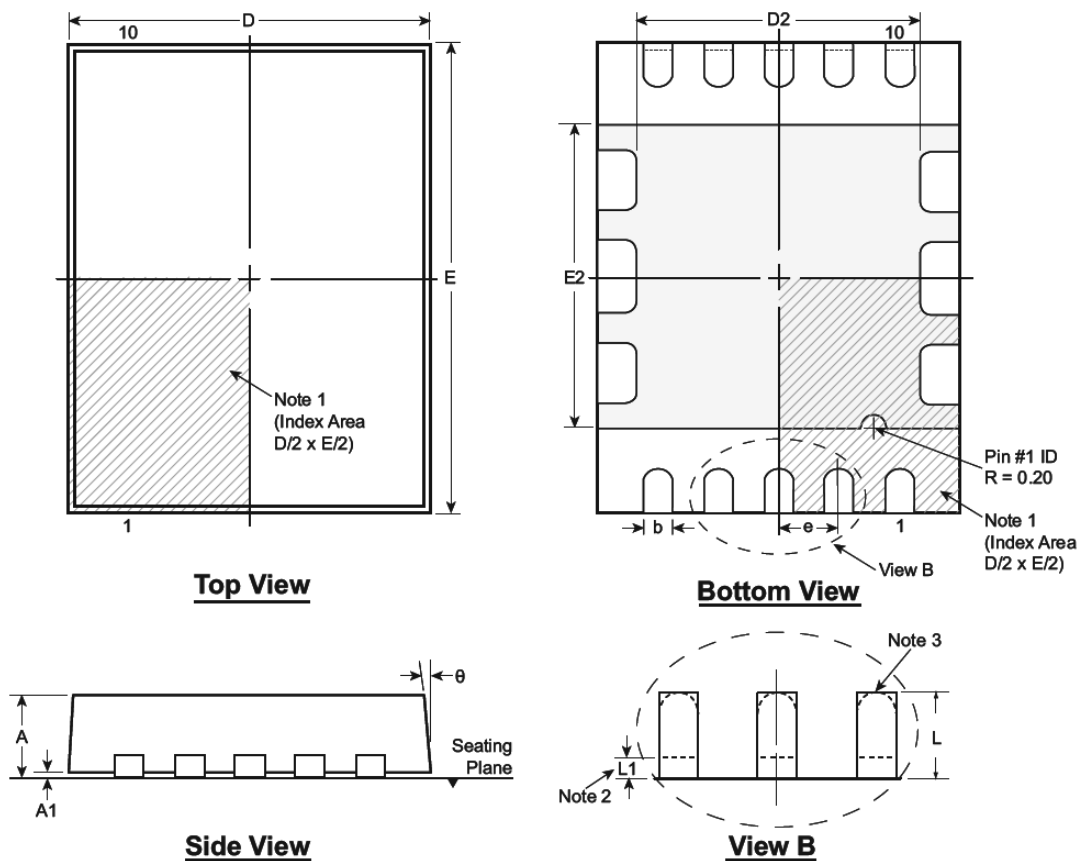

Note: For the most current package drawings, see the Microchip Packaging Specification at [www.microchip.com/packaging](http://www.microchip.com/packaging).

**Notes:**

1. A Pin 1 identifier must be located in the index area indicated. The Pin 1 identifier can be: a molded mark/identifier; an embedded metal marker; or a printed indicator.
2. Depending on the method of manufacturing, a maximum of 0.15mm pullback (L1) may be present.
3. The inner tip of the lead may be either rounded or square.

Symbol	A	A1	b	D	D2	E	E2	e	L	L1	$\theta$	
Dimension (mm)	MIN	0.80	0.00	0.18	2.95	2.20	3.95	2.50	0.50 BSC	0.30	0.00	0°
	NOM	0.90	0.02	0.25	3.00	2.35	4.00	2.65		0.40	-	-
	MAX	1.00	0.05	0.30	3.05	2.45	4.05	2.75		0.50	0.15	14°

Drawings not to scale.

---



---

## Package Outlines and Dimensions

---



---

### 12-Lead DFN Package Outline (K6)

4.00x4.00mm body, 1.00mm height (max), 0.50mm pitch

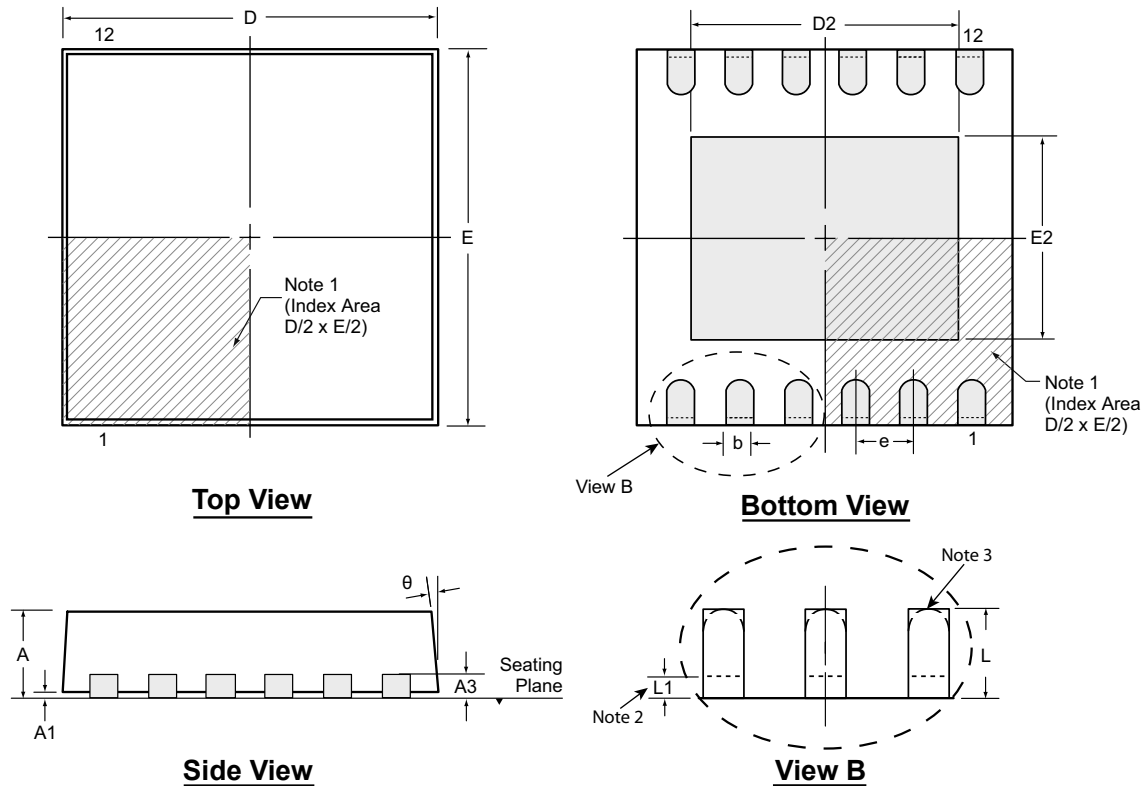

Note: For the most current package drawings, see the Microchip Packaging Specification at [www.microchip.com/packaging](http://www.microchip.com/packaging).

**Notes:**

1. A Pin 1 identifier must be located in the index area indicated. The Pin 1 identifier can be: a molded mark/identifier; an embedded metal marker; or a printed indicator.
2. Depending on the method of manufacturing, a maximum of 0.15mm pullback ( $L_1$ ) may be present.
3. The inner tip of the lead may be either rounded or square.

Symbol	A	A1	A3	b	D	D2	E	E2	e	L	L1	$\theta$	
Dimension (mm)	MIN	0.80	0.00	0.20 REF	0.18	3.85	3.19	3.85	2.29	0.50 BSC	0.30	0.00	0°
	NOM	0.90	0.02		0.25	4.00	3.34	4.00	2.44		0.40	-	-
	MAX	1.00	0.05		0.30	4.15	3.44	4.15	2.54		0.50	0.15	14°

Drawings not to scale.

**Package Outlines and Dimensions**

**18-Lead DFN Package Outline (K6)**  
**5.00x5.00mm body, 1.00mm height (max), 0.50mm pitch**

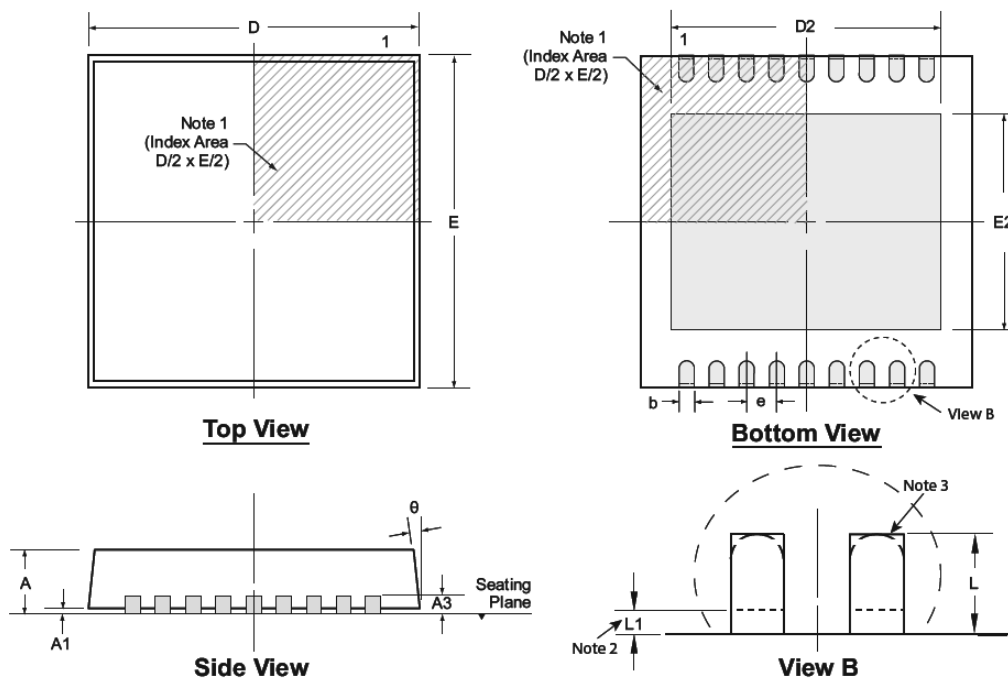

Note: For the most current package drawings, see the Microchip Packaging Specification at [www.microchip.com/packaging](http://www.microchip.com/packaging).

**Notes:**

1. A Pin 1 identifier must be located in the index area indicated. The Pin 1 identifier can be: a molded mark/identifier, an embedded metal marker, or a printed indicator.
2. Depending on the method of manufacturing, a maximum of 0.15mm pullback (L1) may be present.
3. The inner tip of the lead may be either rounded or square.

Symbol	A	A1	A3	b	D	D2	E	E2	e	L	L1	$\theta$	
Dimension (mm)	MIN	0.80	0.00	0.20 REF	0.18	4.85*	4.20 <sup>†</sup>	4.85*	3.50 <sup>†</sup>	0.50 BSC	0.30 <sup>†</sup>	0.00*	0°
	NOM	0.90	0.02		0.25	5.00	4.35 <sup>†</sup>	5.00	3.65 <sup>†</sup>		0.40 <sup>†</sup>	-	-
	MAX	1.00	0.05		0.30	5.15*	4.45 <sup>†</sup>	5.15*	3.75 <sup>†</sup>		0.50 <sup>†</sup>	0.15	14°

JEDEC Registration MO-229, Variation VJJD-2, Issue C, Aug 2003.

\* This dimension is not specified in the JEDEC drawing.

† This dimension differs from the JEDEC drawing.

**Drawings not to scale.**

---



---

## Package Outlines and Dimensions

---



---

### 8-Lead DFN Package Outline (K7)

3.00x3.00mm body, 0.80mm height (max), 0.65mm pitch

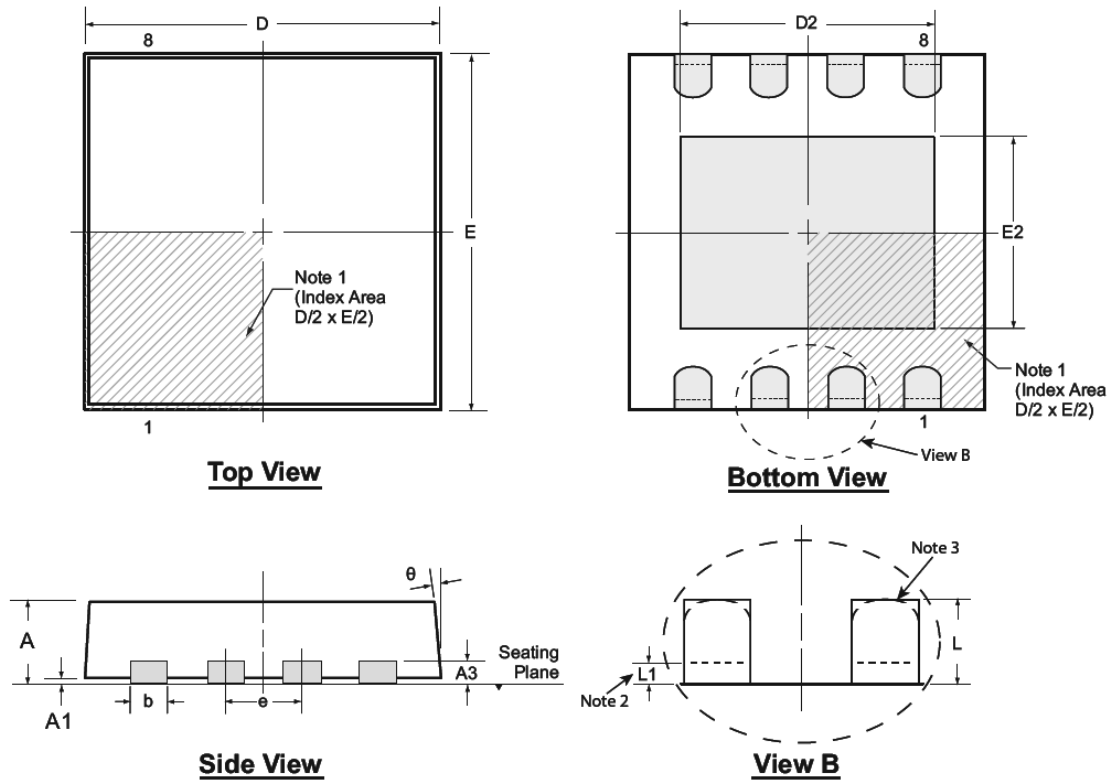

Note: For the most current package drawings, see the Microchip Packaging Specification at [www.microchip.com/packaging](http://www.microchip.com/packaging).

**Notes:**

1. A Pin 1 identifier must be located in the index area indicated. The Pin 1 identifier can be: a molded mark/identifier; an embedded metal marker; or a printed indicator.
2. Depending on the method of manufacturing, a maximum of 0.15mm pullback (L1) may be present.
3. The inner tip of the lead may be either rounded or square.

Symbol	A	A1	A3	b	D	D2	E	E2	e	L	L1	$\theta$	
Dimension (mm)	MIN	0.70	0.00	0.20 REF	0.25	2.85*	1.60	2.85*	1.35	0.65 BSC	0.30	0.00*	0°
	NOM	0.75	0.02		0.30	3.00	-	3.00	-		0.40	-	-
	MAX	0.80	0.05		0.35	3.15*	2.50	3.15*	1.75		0.50	0.15	14°

JEDEC Registration MO-229, Variation WEEC-2, Issue C, Aug. 2003.

\* This dimension is not specified in the JEDEC drawing.

Drawings not to scale.

## Package Outlines and Dimensions

### 10-Lead DFN Package Outline (K7)

3.00x3.00mm body, 0.80mm height (max), 0.50mm pitch

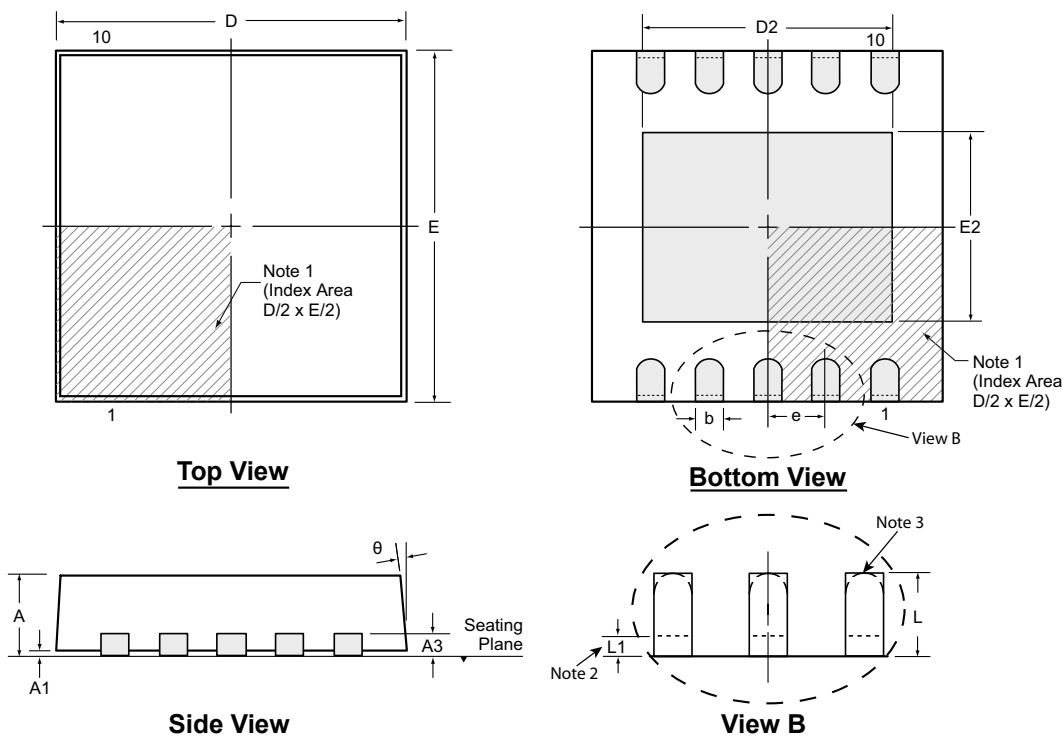

Note: For the most current package drawings, see the Microchip Packaging Specification at [www.microchip.com/packaging](http://www.microchip.com/packaging).

**Notes:**

1. A Pin 1 identifier must be located in the index area indicated. The Pin 1 identifier can be: a molded mark/identifier; an embedded metal marker; or a printed indicator.
2. Depending on the method of manufacturing, a maximum of 0.15mm pullback (L1) may be present.
3. The inner tip of the lead may be either rounded or square.

Symbol	A	A1	A3	b	D	D2	E	E2	e	L	L1	$\theta$	
Dimension (mm)	MIN	0.70	0.00	0.20 REF	0.18	2.85*	2.20	2.85*	1.40	0.50 BSC	0.30	0.00*	0°
	NOM	0.75	0.02		0.25	3.00	-	3.00	-		0.40	-	-
	MAX	0.80	0.05		0.30	3.15*	2.70	3.15*	1.75		0.50	0.15	14°

JEDEC Registration MO-229, Variation WEED-5, Issue C, Aug. 2003.

\* This dimension is not specified in the JEDEC drawing.

---



---

## Package Outlines and Dimensions

---



---

### 10-Lead DFN Package Outline (K7)

4.00x4.00mm body, 0.80mm height (max), 0.65mm pitch

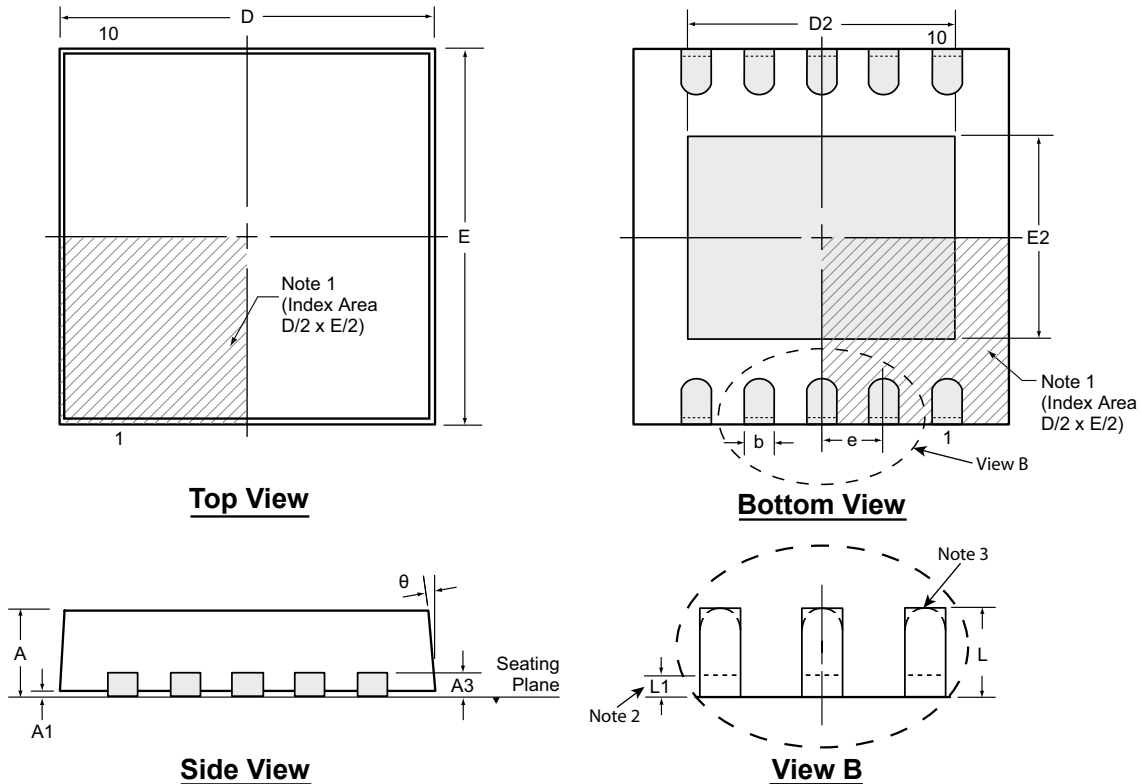

Note: For the most current package drawings, see the Microchip Packaging Specification at [www.microchip.com/packaging](http://www.microchip.com/packaging).

**Notes:**

1. A Pin 1 identifier must be located in the index area indicated. The Pin 1 identifier can be: a molded mark/identifier; an embedded metal marker; or a printed indicator.
2. Depending on the method of manufacturing, a maximum of 0.15mm pullback ( $L1$ ) may be present.
3. The inner tip of the lead may be either rounded or square.

Symbol	A	A1	A3	b	D	D2	E	E2	e	L	L1	$\theta$	
Dimension (mm)	MIN	0.70	0.00	0.20 REF	0.25	3.85*	2.80	3.85*	2.30	0.65 BSC	0.30	0.00*	0°
	NOM	0.75	0.02		0.30	4.00	-	4.00	-		0.40	-	-
	MAX	0.80	0.05		0.35	4.15*	3.50	4.15*	2.80		0.50	0.15	14°

JEDEC Registration MO-229, Variation WGGC, Issue C, Aug. 2003.

\* This dimension is not specified in the JEDEC drawing.

Drawings not to scale.



**MICROCHIP**

---

---

**Package Outlines and Dimensions**

---

---

NOTES:



---

---

**Package Outlines and Dimensions**

---

---

**LLGA**

Supertex Legacy

## Package Outlines and Dimensions

### 26-Lead LLGA Package Outline (G1)

6.00x6.00mm body, 0.60mm height (max), 0.65mm pitch

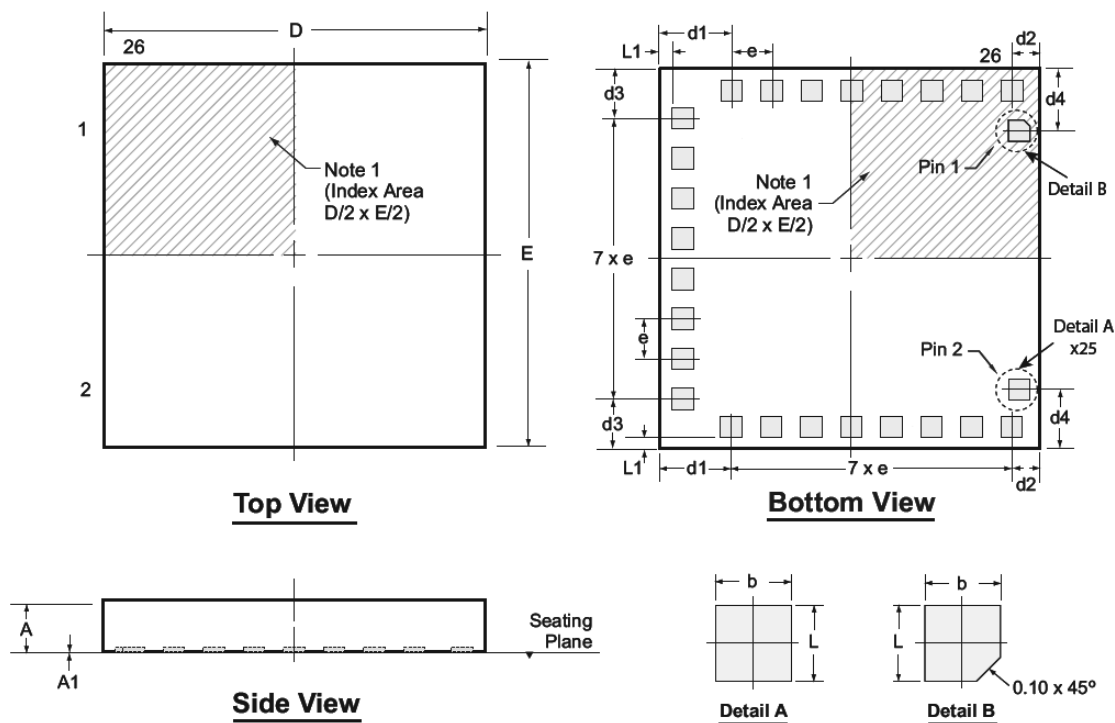

Note: For the most current package drawings, see the Microchip Packaging Specification at [www.microchip.com/packaging](http://www.microchip.com/packaging).

**Note:**

1. A Pin 1 identifier must be located in the index area indicated. The Pin 1 identifier can be: a molded mark/identifier; an embedded metal marker; or a printed indicator.

Symbol	A	A1	b	D	d1	d2	d3	d4	E	e	L	L1
Dimension (mm)	MIN	0.50	0.00	0.25	5.90	1.050	0.400	0.725	0.925	5.90	0.65 BSC	0.25
	NOM	0.55	-	0.35	6.00	REF	REF	REF	REF	6.00		0.35
	MAX	0.60	0.05	0.45	6.10	REF	REF	REF	REF	6.10		0.45

Drawings not to scale.

---

---

**Package Outlines and Dimensions**

---

---

**LFGA**

Supertex Legacy

**Package Outlines and Dimensions**

**6-Lead LFGA Package Outline (LA)**

*3.00x3.00mm body, 0.85mm height (max), 0.65mm pitch*

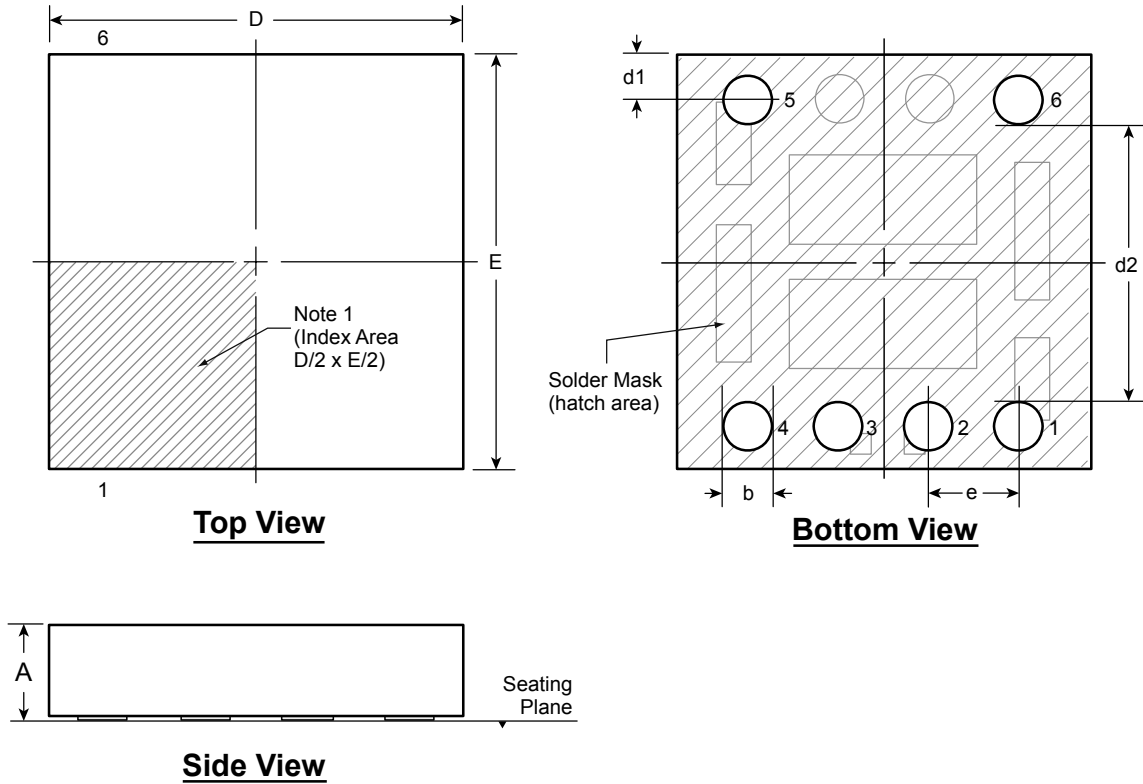

Note: For the most current package drawings, see the Microchip Packaging Specification at [www.microchip.com/packaging](http://www.microchip.com/packaging).

**Notes:**

1. A Pin 1 identifier must be located in the index area indicated. The Pin 1 identifier can be: a molded mark/identifier; an embedded metal marker; or a printed indicator.

Symbol		A	b	D	E	d1	d2	e
Dimension (mm)	MIN	0.75	0.30	2.925	2.925	0.225	2.00 BSC	0.65 BSC
	NOM	0.80	0.35	3.000	3.000	0.325		
	MAX	0.85	0.40	3.075	3.075	0.425		

Drawings not to scale

---



---

## Package Outlines and Dimensions

---



---

### 22-Lead LFGA Package Outline (LA)

5.00x7.00mm body, 0.85mm height (max), 0.50mm pitch

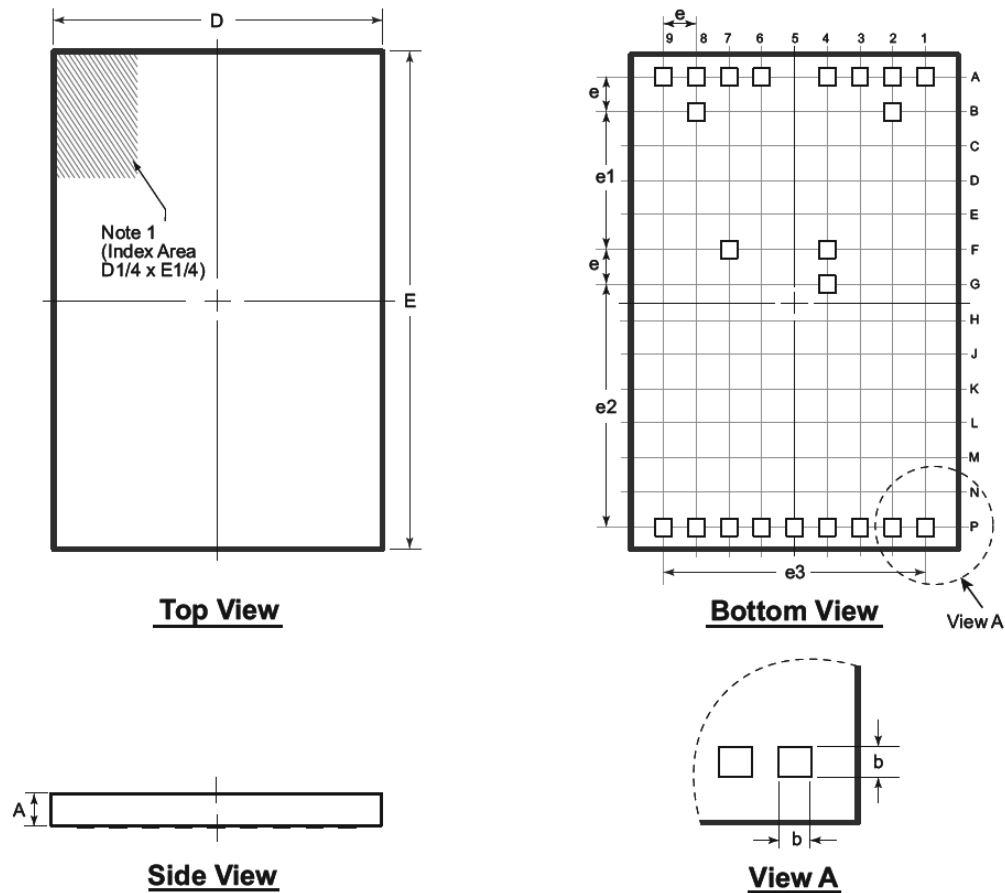

Note: For the most current package drawings, see the Microchip Packaging Specification at [www.microchip.com/packaging](http://www.microchip.com/packaging).

**Notes:**

1. A Pin 1 identifier must be located in the index area indicated. The Pin 1 identifier can be: a molded mark/identifier; an embedded metal marker; or a printed indicator.

Symbol		A	b	D	E	e	e1	e2	e3
Dimension (mm)	MIN	0.75	0.20	4.925	6.925	0.50 BSC	2.00 BSC	3.50 BSC	4.00 BSC
	NOM	0.80	0.25	5.000	7.000				
	MAX	0.85	0.30	5.075	7.075				

Drawings not to scale.

**Package Outlines and Dimensions**

**64-Pad LFGA Package Outline (LA)**

*7.00x7.00mm body, 0.85mm height (max), 0.65mm pitch*

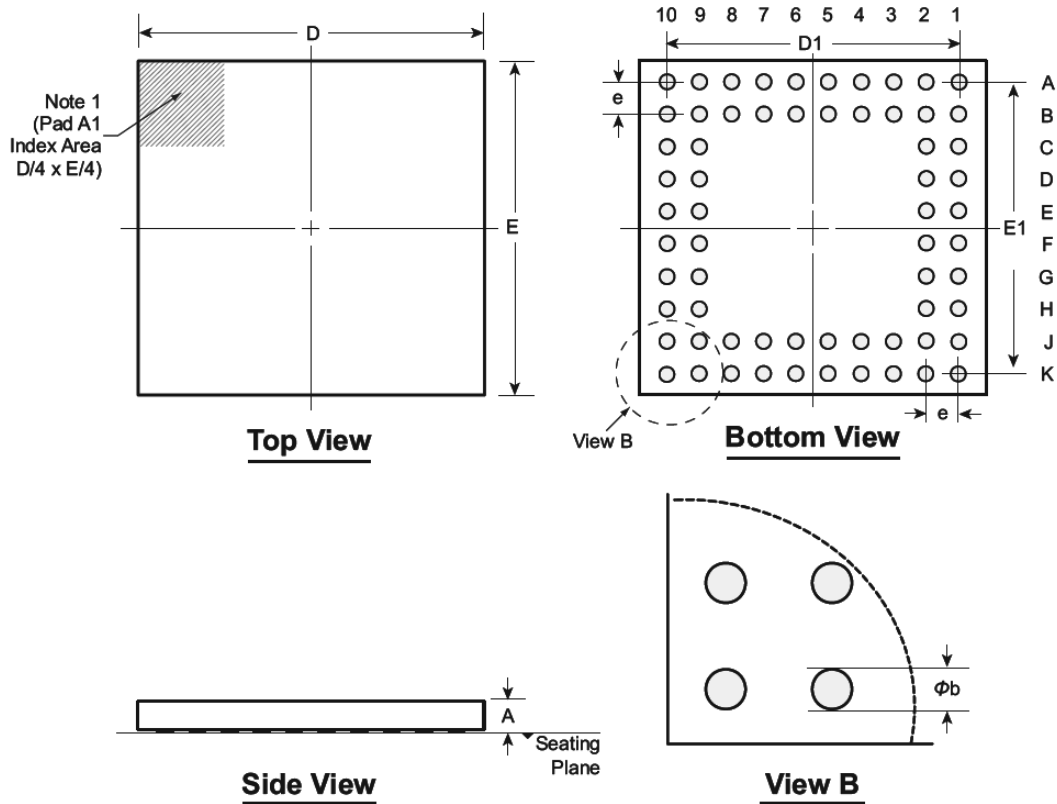

Note: For the most current package drawings, see the Microchip Packaging Specification at [www.microchip.com/packaging](http://www.microchip.com/packaging).

**Notes:**

1. Pad A1 identifier must be located in the index area indicated. Pad A1 identifier can be: a molded mark/identifier, an embedded metal marker, or a printed indicator.

Symbol		A	b	D	D1	E	E1	e
Dimension (mm)	MIN	0.75	0.25	6.925	5.85 BSC	6.925	5.85 BSC	0.65 BSC
	NOM	0.80	0.30	7.000		7.000		
	MAX	0.85	0.35	7.075		7.075		

*Drawings not to scale.*

---



---

## Package Outlines and Dimensions

---



---

### 64-Ball LFGA Package Outline (LB)

**7.00x7.00mm body, 1.00mm height (max), 0.65mm pitch**

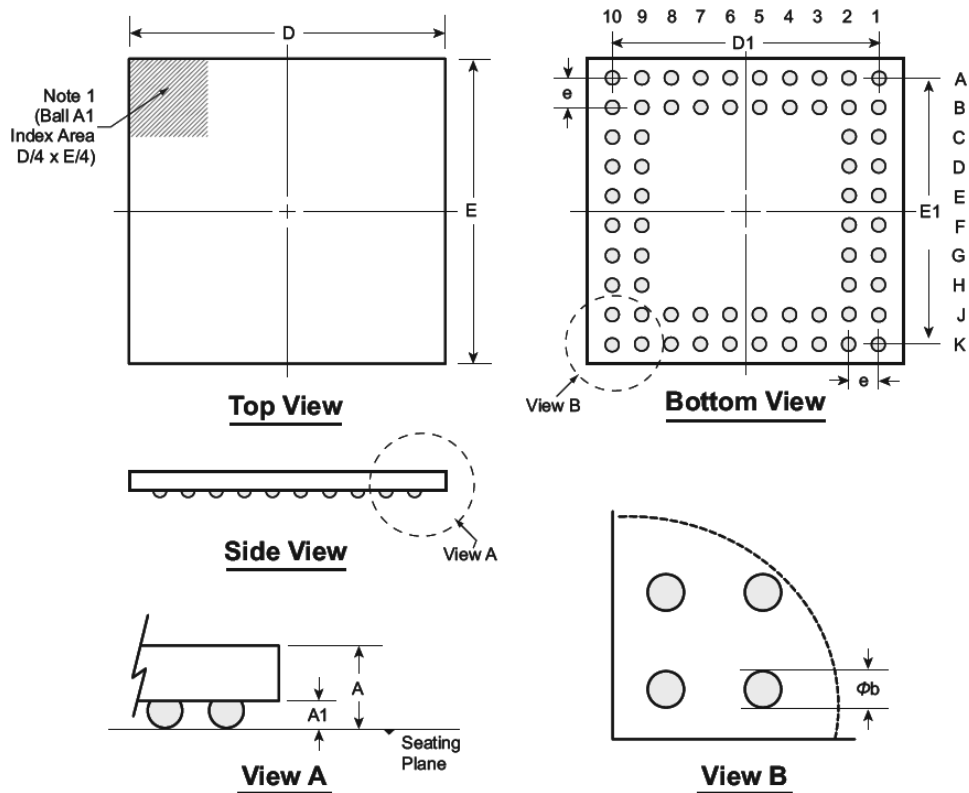

Note: For the most current package drawings, see the Microchip Packaging Specification at [www.microchip.com/packaging](http://www.microchip.com/packaging).

**Notes:**

- Ball A1 identifier must be located in the index area indicated. Ball A1 identifier can be: a molded mark/identifier; an embedded metal marker; or a printed indicator.

Symbol		A	A1	b	D	D1	E	E1	e
Dimension (mm)	MIN	0.90	0.10	0.25	6.925	5.85 BSC	6.925	5.85 BSC	0.65 BSC
	NOM	0.95	0.15	0.30	7.000		7.000		
	MAX	1.00	0.20	0.35	7.075		7.075		

Drawings not to scale.



**MICROCHIP**

---

---

**Package Outlines and Dimensions**

---

---

NOTES:



---

---

**Package Outlines and Dimensions**

---

---

**LQFP**

Supertex Legacy

## Package Outlines and Dimensions

### 32-Lead LQFP Package Outline (FG)

7.00x7.00mm body, 1.60mm height (max), 0.80mm pitch

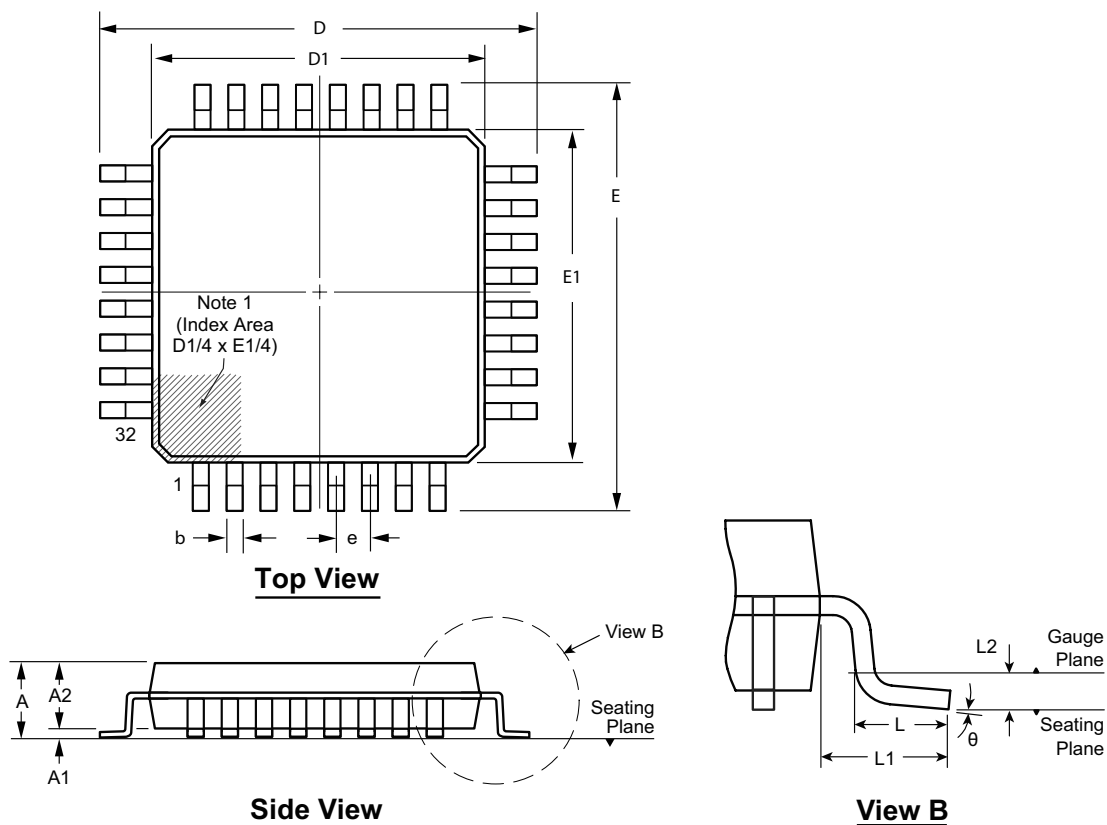

Note: For the most current package drawings, see the Microchip Packaging Specification at [www.microchip.com/packaging](http://www.microchip.com/packaging).

**Note:**

1. A Pin 1 identifier must be located in the index area indicated. The Pin 1 identifier can be: a molded mark/identifier; an embedded metal marker; or a printed indicator.

Symbol		A	A1	A2	b	D	D1	E	E1	e	L	L1	L2	$\theta$
Dimension (mm)	MIN	1.40*	0.05	1.35	0.30	8.80*	6.80*	8.80*	6.80*	0.80 BSC	0.45	1.00 REF	0.25 BSC	0°
	NOM	-	-	1.40	0.37	9.00	7.00	9.00	7.00		0.60			3.5°
	MAX	1.60	0.15	1.45	0.45	9.20*	7.20*	9.20*	7.20*		0.75			7°

JEDEC Registration MS-026, Variation BBA, Issue D, Jan. 2001.

\* This dimension is not specified in the JEDEC drawing.

**Drawings are not to scale.**

## Package Outlines and Dimensions

### 48-Lead LQFP Package Outline (FG)

**7.00x7.00mm body, 1.60mm height (max), 0.50mm pitch**

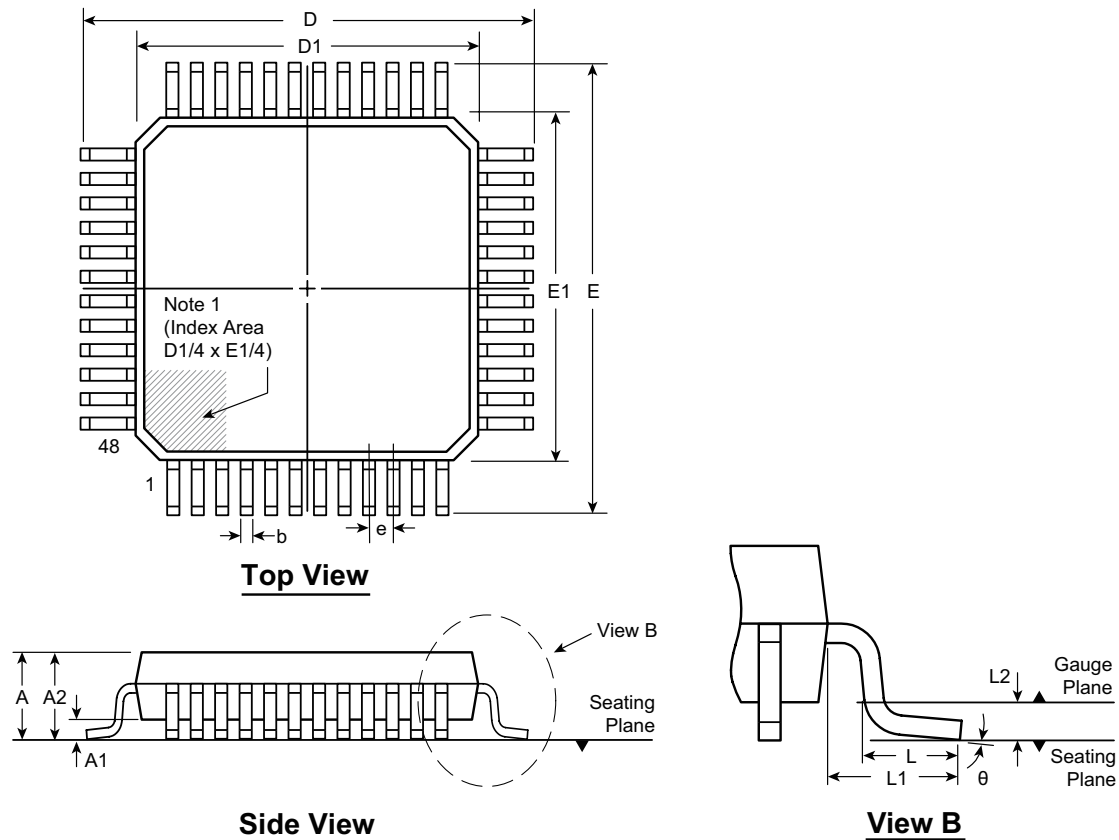

Note: For the most current package drawings, see the Microchip Packaging Specification at [www.microchip.com/packaging](http://www.microchip.com/packaging).

**Note:**

1. A Pin 1 identifier must be located in the index area indicated. The Pin 1 identifier can be: a molded mark/identifier; an embedded metal marker; or a printed indicator.

Symbol	A	A1	A2	b	D	D1	E	E1	e	L	L1	L2	θ	
Dimension (mm)	MIN	1.40*	0.05	1.35	0.17	8.80*	6.80*	8.80*	6.80*	0.50 BSC	0.45	1.00 REF	0.25 BSC	0°
	NOM	-	-	1.40	0.22	9.00	7.00	9.00	7.00		0.60		3.5°	
	MAX	1.60	0.15	1.45	0.27	9.20*	7.20*	9.20*	7.20*		0.75		7°	

JEDEC Registration MS-026, Variation BBC, Issue D, Jan. 2001.

\* This dimension is not specified in the JEDEC drawing.

Drawings are not to scale.



**MICROCHIP**

---

---

**Package Outlines and Dimensions**

---

---

**NOTES:**

---

---

**Package Outlines and Dimensions**

---

---

**MQFP**

Supertex Legacy

**Package Outlines and Dimensions**

**100-Lead MQFP Package Outline (FG)**

*20.00x14.00mm body, 3.15mm height (max), 0.65mm pitch, 3.20mm footprint*

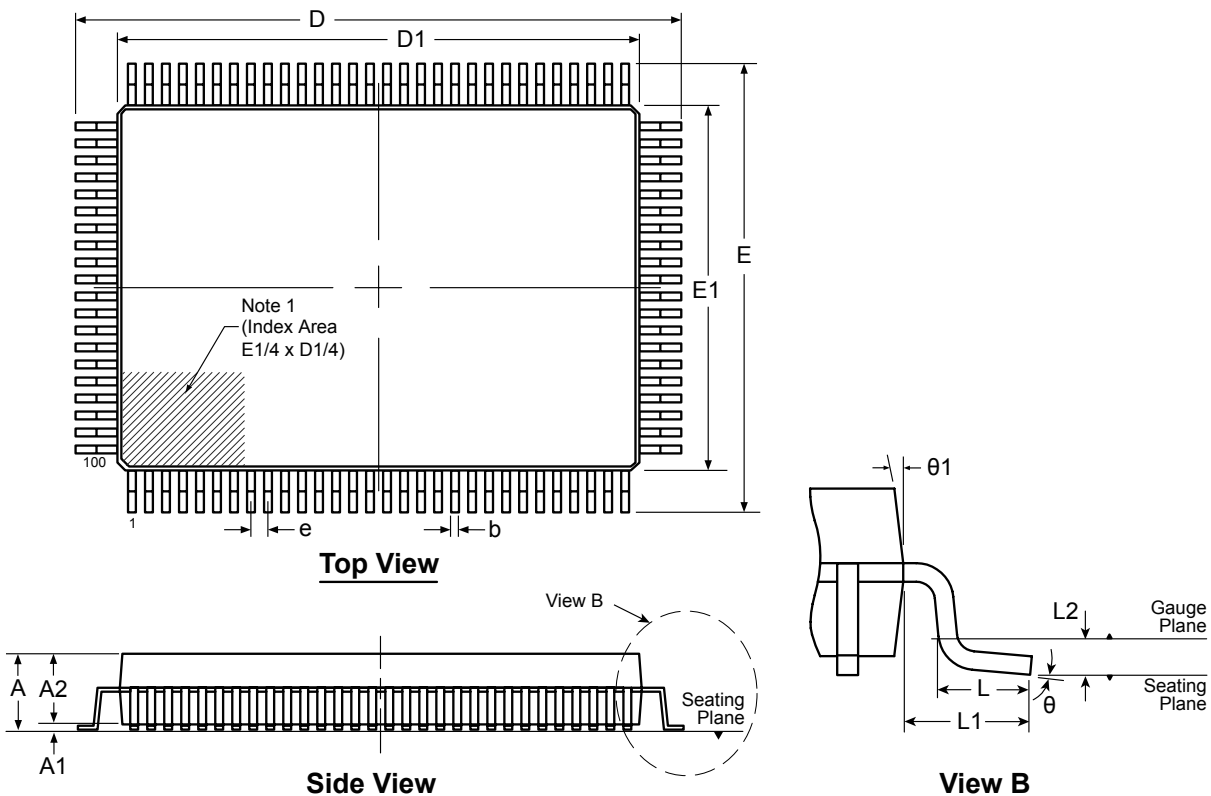

Note: For the most current package drawings, see the Microchip Packaging Specification at [www.microchip.com/packaging](http://www.microchip.com/packaging).

**Note:**

1. A Pin 1 identifier must be located in the index area indicated. The Pin 1 identifier can be: a molded mark/identifier; an embedded metal marker; or a printed indicator.

Symbol	A	A1	A2	b	D	D1	E	E1	e	L	L1	L2	θ	θ1	
Dimension (mm)	MIN	2.50*	0.00	2.50	0.22	22.95*	19.80*	16.95*	13.80*	0.65 BSC	0.73	1.60 REF	0.25 BSC	0°	5°
	NOM	-	-	2.70	-	23.20	20.00	17.20	14.00		0.88			-	-
	MAX	3.15	0.25	2.90	0.40	23.45*	20.20*	17.45*	14.20*		1.03			7°	16°

JEDEC Registration MS-022, Variation GC-2, Issue B, Dec. 1996.

\* This dimension is not specified in the JEDEC drawing.

Drawings are not to scale.

---

---

**Package Outlines and Dimensions**

---

---

**MSOP**

Supertex Legacy

**Package Outlines and Dimensions**

**8-Lead MSOP Package Outline (MG)**

**3.00x3.00mm body, 1.10mm height (max), 0.65mm pitch**

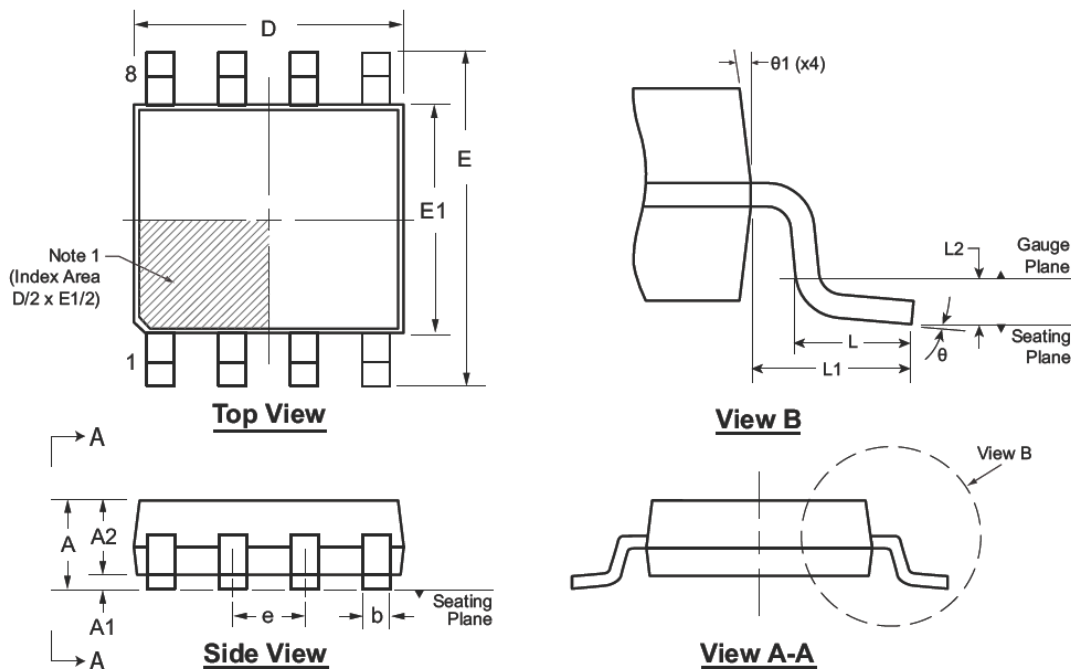

Note: For the most current package drawings, see the Microchip Packaging Specification at [www.microchip.com/packaging](http://www.microchip.com/packaging).

**Note:**

1. A Pin 1 identifier must be located in the index area indicated. The Pin 1 identifier can be: a molded mark/identifier; an embedded metal marker; or a printed indicator.

Symbol	A	A1	A2	b	D	E	E1	e	L	L1	L2	θ	θ1	
Dimension (mm)	MIN	0.75*	0.00	0.75	0.22	2.80*	4.65*	2.80*	0.65 BSC	0.95 REF	0.25 BSC	0°	5°	
	NOM	-	-	0.85	-	3.00	4.90	3.00				0.60	-	-
	MAX	1.10	0.15	0.95	0.38	3.20*	5.15*	3.20*				0.80	8°	15°

JEDEC Registration MO-187, Variation AA, Issue E, Dec. 2004.

\* This dimension is not specified in the JEDEC drawing.

Drawings are not to scale.



---



---

## Package Outlines and Dimensions

---



---

### 10-Lead MSOP Package Outline (MG)

**3.00x3.00mm body, 1.10mm height (max), 0.50mm pitch**

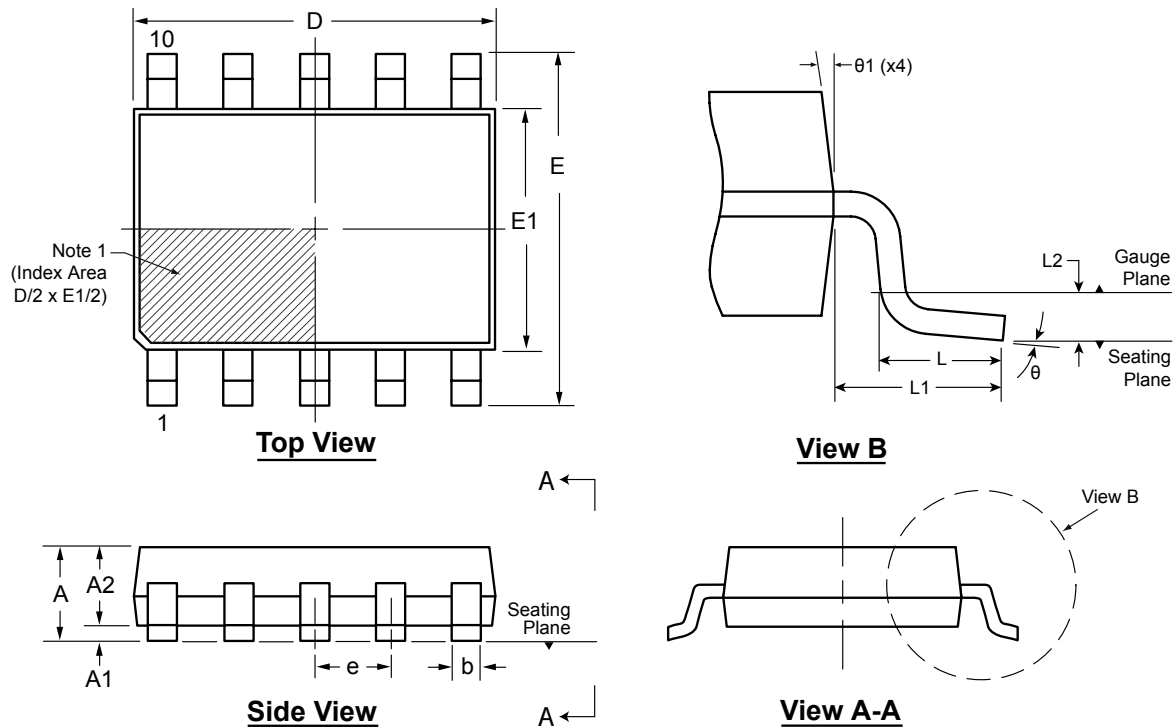

Note: For the most current package drawings, see the Microchip Packaging Specification at [www.microchip.com/packaging](http://www.microchip.com/packaging).

**Note:**

1. A Pin 1 identifier must be located in the index area indicated. The Pin 1 identifier can be: a molded mark/identifier; an embedded metal marker; or a printed indicator.

Symbol	A	A1	A2	b	D	E	E1	e	L	L1	L2	$\theta$	$\theta 1$	
Dimension (mm)	MIN	0.75*	0.00	0.75	0.17	2.80*	4.65*	2.80*	0.50 BSC	0.40	0.95 REF	0.25 BSC	0°	5°
	NOM	-	-	0.85	-	3.00	4.90	3.00		0.60			-	-
	MAX	1.10	0.15	0.95	0.33	3.20*	5.15*	3.20*		0.80			8°	15°

JEDEC Registration MO-187, Variation BA, Issue E, Dec. 2004.

\* This dimension is not specified in the JEDEC drawing.

Drawings are not to scale.



**MICROCHIP**

---

---

**Package Outlines and Dimensions**

---

---

NOTES:

---

---

**Package Outlines and Dimensions**

---

---

**PDIP**

Supertex Legacy

**Package Outlines and Dimensions**

**14-Lead PDIP (.300in Row Spacing) Package Outline (P)**  
*.750x.250in body, .210in height (max), .100in pitch*

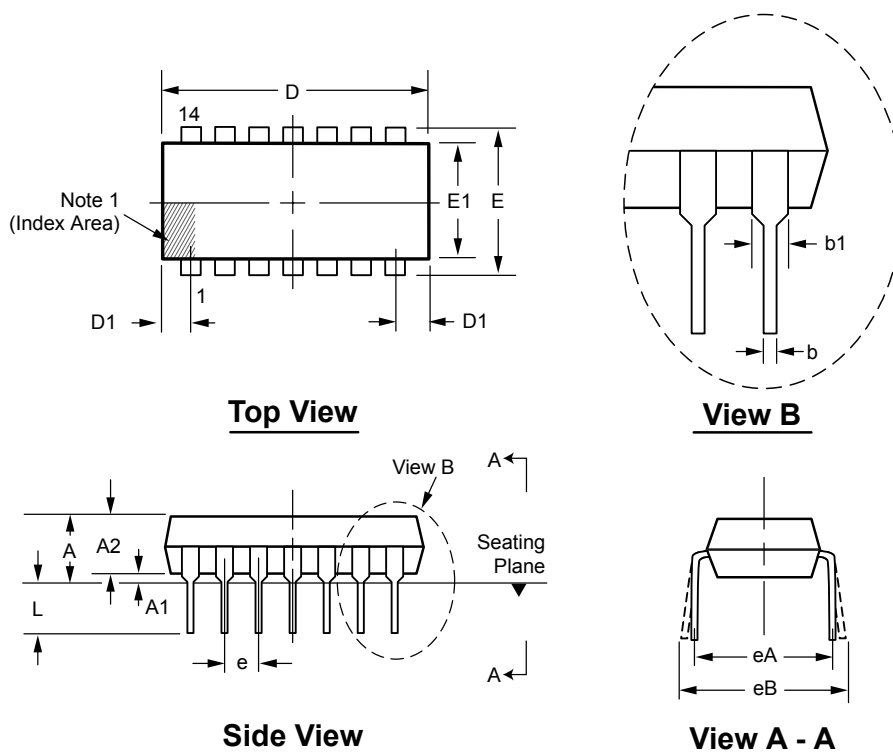

Note: For the most current package drawings, see the Microchip Packaging Specification at [www.microchip.com/packaging](http://www.microchip.com/packaging).

**Note:**

1. A Pin 1 identifier must be located in the index area indicated. The Pin 1 identifier can be: a molded mark/identifier; an embedded metal marker; or a printed indicator.

Symbol	A	A1	A2	b	b1	D	D1	E	E1	e	eA	eB	L	
Dimension (inches)	MIN	.130*	.015	.115	.014	.045	.735	.065 <sup>†</sup>	.290 <sup>†</sup>	.240	.100 BSC	.300 BSC	.300*	.115
	NOM	-	-	.130	.018	.060	.750	-	.310	.250			-	.130
	MAX	.210	.035*	.195	.023 <sup>†</sup>	.070	.810 <sup>†</sup>	.085*	.325	.280			.430	.150

JEDEC Registration MS-001, Variation AA, Issue D, June, 1993.

\* This dimension is not specified in the JEDEC drawing.

† This dimension differs from the JEDEC drawing.

**Drawings not to scale.**

---



---

## Package Outlines and Dimensions

---



---

### 16-Lead PDIP (.300in Row Spacing) Package Outline (P) .790x.250in body, .210in height (max), .100in pitch

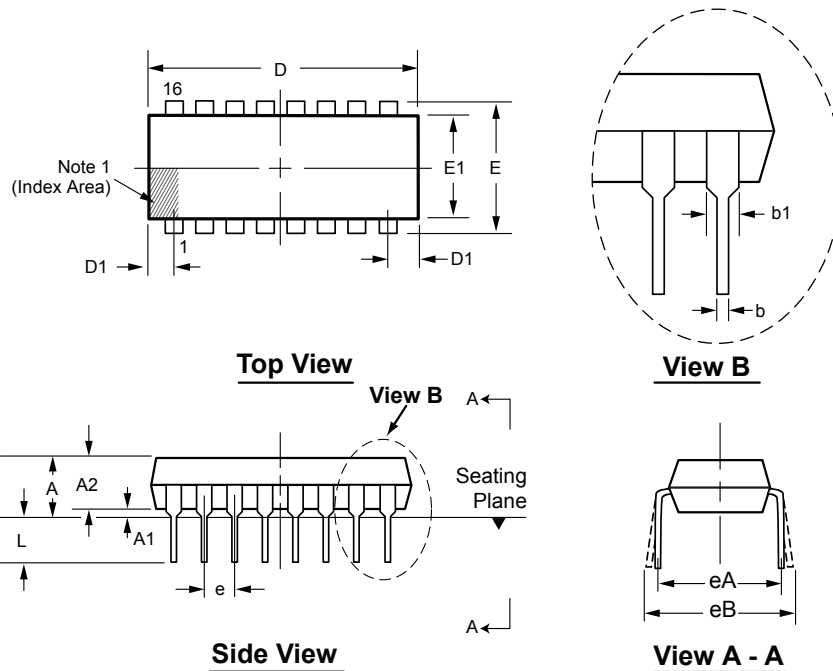

Note: For the most current package drawings, see the Microchip Packaging Specification at [www.microchip.com/packaging](http://www.microchip.com/packaging).

**Note:**

1. A Pin 1 identifier must be located in the index area indicated. The Pin 1 identifier can be: a molded mark/identifier; an embedded metal marker; or a printed indicator.

Symbol	A	A1	A2	b	b1	D	D1	E	E1	e	eA	eB	L	
Dimension (inches)	MIN	.130*	.015	.115	.014	.045	.745 <sup>†</sup>	.005	.290 <sup>†</sup>	.240	.100 BSC	.300 BSC	.300*	.115
	NOM	-	-	.130	.018	.060	.790	-	.310	.250			-	.130
	MAX	.210	.035*	.195	.023 <sup>†</sup>	.070	.810 <sup>†</sup>	.050*	.325	.280			.430	.150

JEDEC Registration MS-001, Variation AB, Issue D, June, 1993.

\* This dimension is not specified in the JEDEC drawing.

† This dimension differs from the JEDEC drawing.

**Drawings not to scale.**

**Package Outlines and Dimensions**

**28-Lead PDIP (.600in Row Spacing) Package Outline (P)**  
**1.565x.580in body, .250in height (max), .100in pitch**

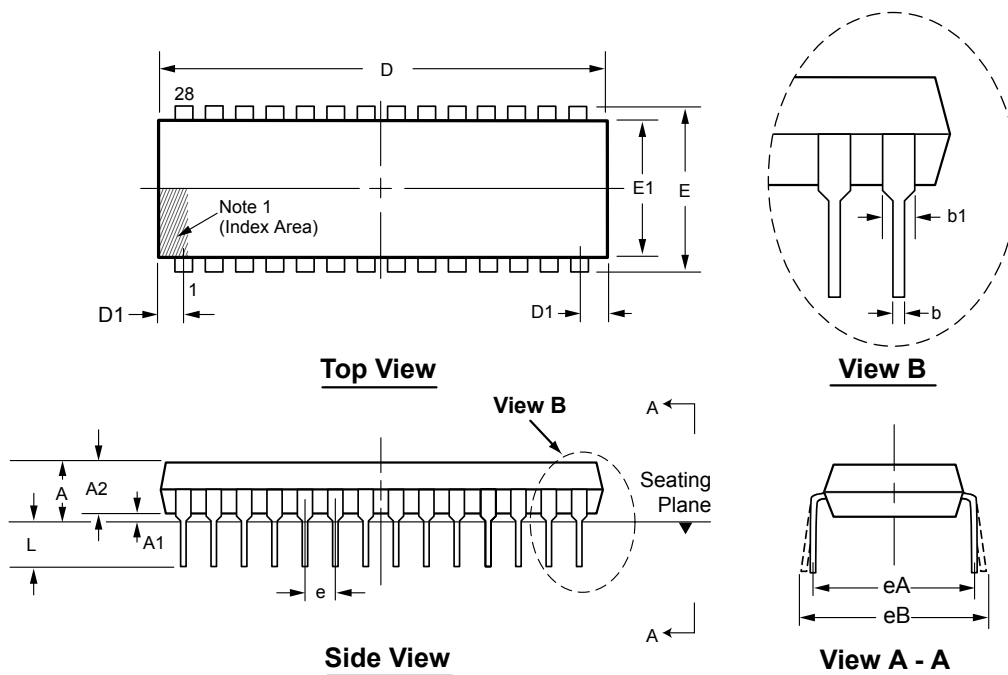

Note: For the most current package drawings, see the Microchip Packaging Specification at [www.microchip.com/packaging](http://www.microchip.com/packaging).

**Note:**

1. A Pin 1 identifier must be located in the index area indicated. The Pin 1 identifier can be: a molded mark/identifier; an embedded metal marker; or a printed indicator.

Symbol	A	A1	A2	b	b1	D	D1	E	E1	e	eA	eB	L		
Dimension (inches)	MIN	.140*	.015	.125	.014	.030	1.380	.065†	.590†	.485	.100 BSC	.600 BSC	.600*	.115	
	NOM	-	-	-	-	-	-	-	-	-			-	-	-
	MAX	.250	.055*	.195	.023†	.070	1.565	.085*	.625	.580			.700	.200	

JEDEC Registration MS-011, Variation AB, Issue B, June, 1988.

\* This dimension is not specified in the JEDEC drawing.

† This dimension differs from the JEDEC drawing.

**Drawings not to scale.**

## Package Outlines and Dimensions

### 40-Lead PDIP (.600in Row Spacing) Package Outline (P) 2.095x.580in body (max), .250in height (max), .100in pitch

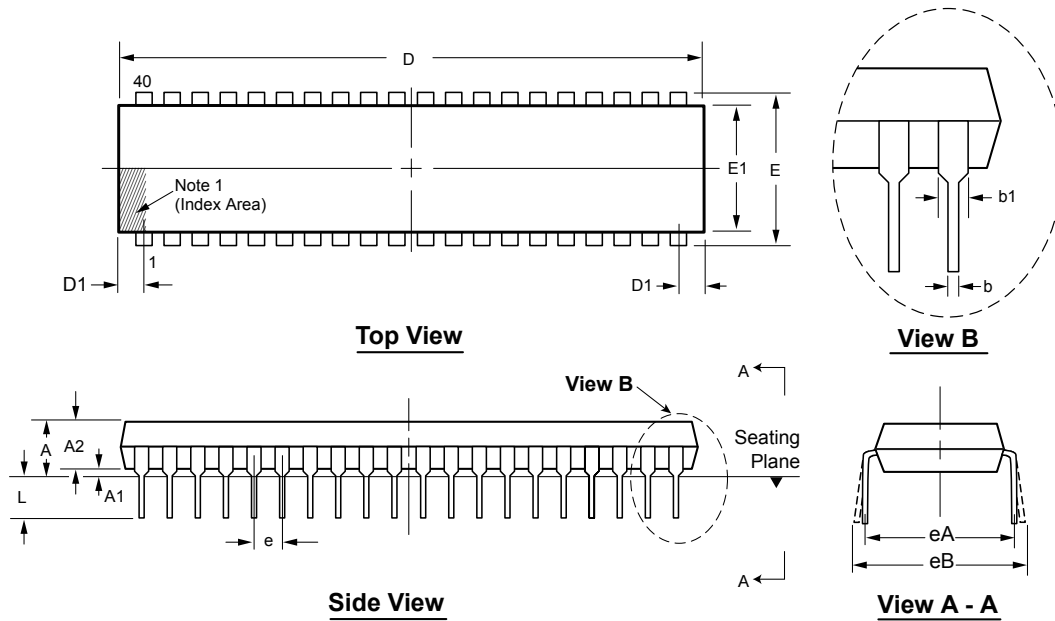

Note: For the most current package drawings, see the Microchip Packaging Specification at [www.microchip.com/packaging](http://www.microchip.com/packaging).

**Note:**

1. A Pin 1 identifier must be located in the index area indicated. The Pin 1 identifier can be: a molded mark/identifier; an embedded metal marker; or a printed indicator.

Symbol	A	A1	A2	b	b1	D	D1	E	E1	e	eA	eB	L	
Dimension (inches)	MIN	.140*	.015	.125	.014	.030	1.980	.065 <sup>†</sup>	.590 <sup>†</sup>	.485	.100 BSC	.600 BSC	.600*	.115
	NOM	-	-	-	-	-	-	-	-	-			-	-
	MAX	.250	.055*	.195	.023 <sup>†</sup>	.070	2.095	.085*	.625	.580			.700	.200

JEDEC Registration MS-011, Variation AC, Issue B, June, 1988.

\* This dimension is not specified in the JEDEC drawing.

† This dimension differs from the JEDEC drawing.

**Drawings not to scale.**



**MICROCHIP**

---

---

**Package Outlines and Dimensions**

---

---

**NOTES:**



---

---

**Package Outlines and Dimensions**

---

---

**PLCC**

Supertex Legacy

**Package Outlines and Dimensions**

**28-Lead PLCC Package Outline (PJ)**

*.453x.453in. body, .180in. height (max), .050in. pitch*

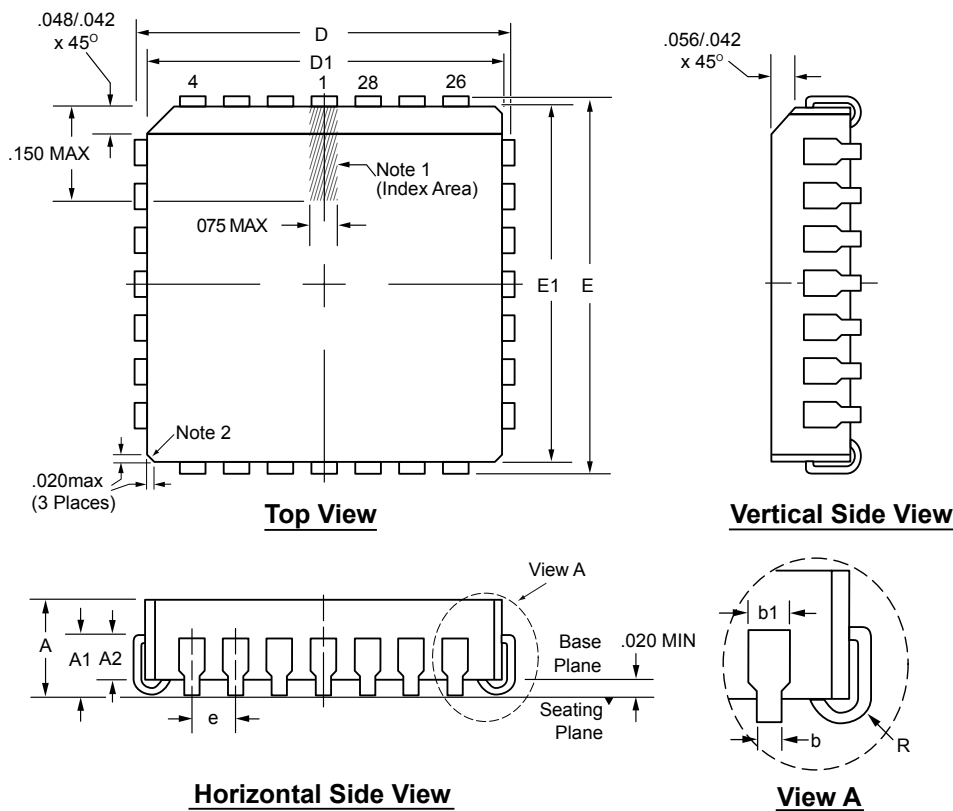

Note: For the most current package drawings, see the Microchip Packaging Specification at [www.microchip.com/packaging](http://www.microchip.com/packaging).

**Notes:**

1. A Pin 1 identifier must be located in the index area indicated. The Pin 1 identifier can be: a molded mark/identifier; an embedded metal marker; or a printed indicator.
2. Actual shape of this feature may vary.

Symbol	A	A1	A2	b	b1	D	D1	E	E1	e	R	
Dimension (inches)	MIN	.165	.090	.062	.013	.026	.485	.450	.485	.450	.050 BSC	.025
	NOM	.172	.105	-	-	-	.490	.453	.490	.453		.035
	MAX	.180	.120	.083	.021	.032	.495	.456	.495	.456		.045

JEDEC Registration MS-018, Variation AB, Issue A, June, 1993.

Drawings not to scale.

## Package Outlines and Dimensions

### 44-Lead PLCC Package Outline (PJ) .653x.653in body, .180in height (max), .050in pitch

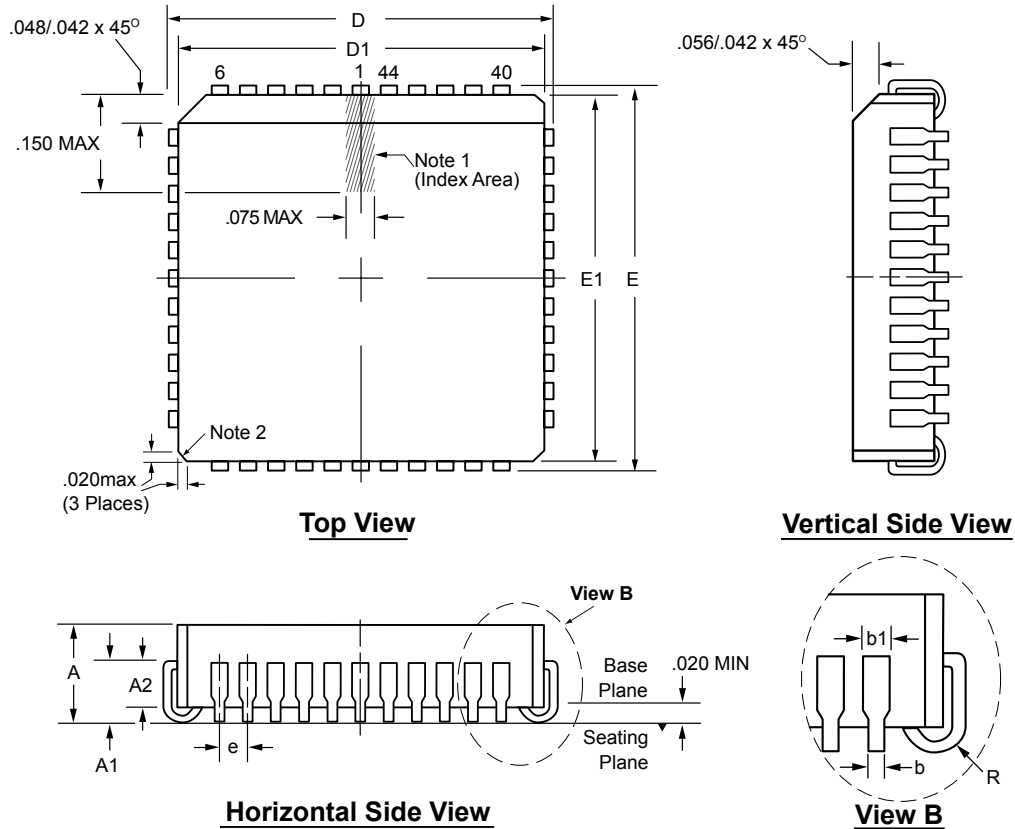

**Note:** For the most current package drawings, see the Microchip Packaging Specification at [www.microchip.com/packaging](http://www.microchip.com/packaging).

**Notes:**

1. A Pin 1 identifier must be located in the index area indicated. The Pin 1 identifier can be: a molded mark/identifier; an embedded metal marker; or a printed indicator.
2. Actual shape of this feature may vary.

Symbol	A	A1	A2	b	b1	D	D1	E	E1	e	R	
Dimension (inches)	MIN	.165	.090	.062	.013	.026	.685	.650	.685	.650	.050 BSC	.025
	NOM	.172	.105	-	-	-	.690	.653	.690	.653		.035
	MAX	.180	.120	.083	.021	.036 <sup>†</sup>	.695	.656	.695	.656		.045

JEDEC Registration MS-018, Variation AC, Issue A, June, 1993.

<sup>†</sup> This dimension differs from the JEDEC drawing.

**Drawings not to scale.**

**Package Outlines and Dimensions**

**20-Lead PLCC Package Outline (PJ)**

**.353x.353in body, .180in height (max), .050in pitch**

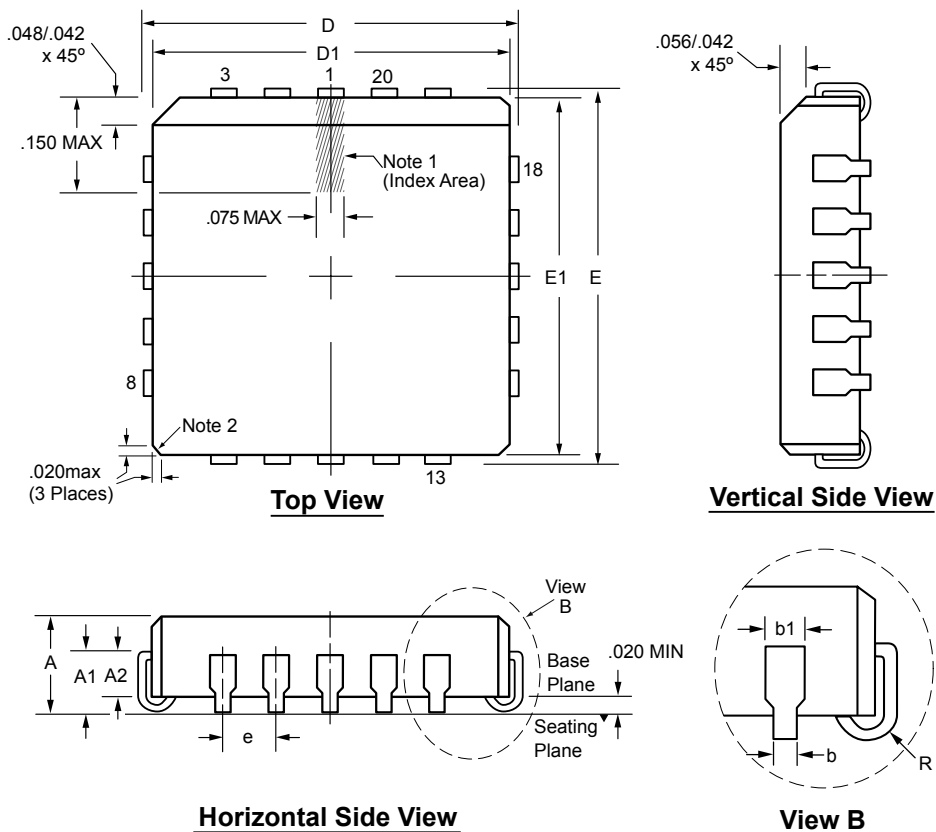

**Note:** For the most current package drawings, see the Microchip Packaging Specification at [www.microchip.com/packaging](http://www.microchip.com/packaging).

**Notes:**

1. A Pin 1 identifier must be located in the index area indicated. The Pin 1 identifier can be: a molded mark/identifier; an embedded metal marker; or a printed indicator.
2. Actual shape of this feature may vary.

Symbol	A	A1	A2	b	b1	D	D1	E	E1	e	R	
Dimension (inches)	MIN	.165	.090	.062	.013	.026	.385	.350	.385	.350	.050 BSC	.025
	NOM	.172	.105	-	-	-	.390	.353	.390	.353		.035
	MAX	.180	.120	.083	.021	.032	.395	.356	.395	.356		.045

JEDEC Registration MS-018, Variation AA, Issue A, June, 1993.  
**Drawings not to scale.**

---

---

**Package Outlines and Dimensions**

---

---

**PQFP**

Supertex Legacy

**Package Outlines and Dimensions**

**44-Lead PQFP Package Outline (PG)**

10.00x10.00mm body, 2.35mm height (max), 0.80mm pitch

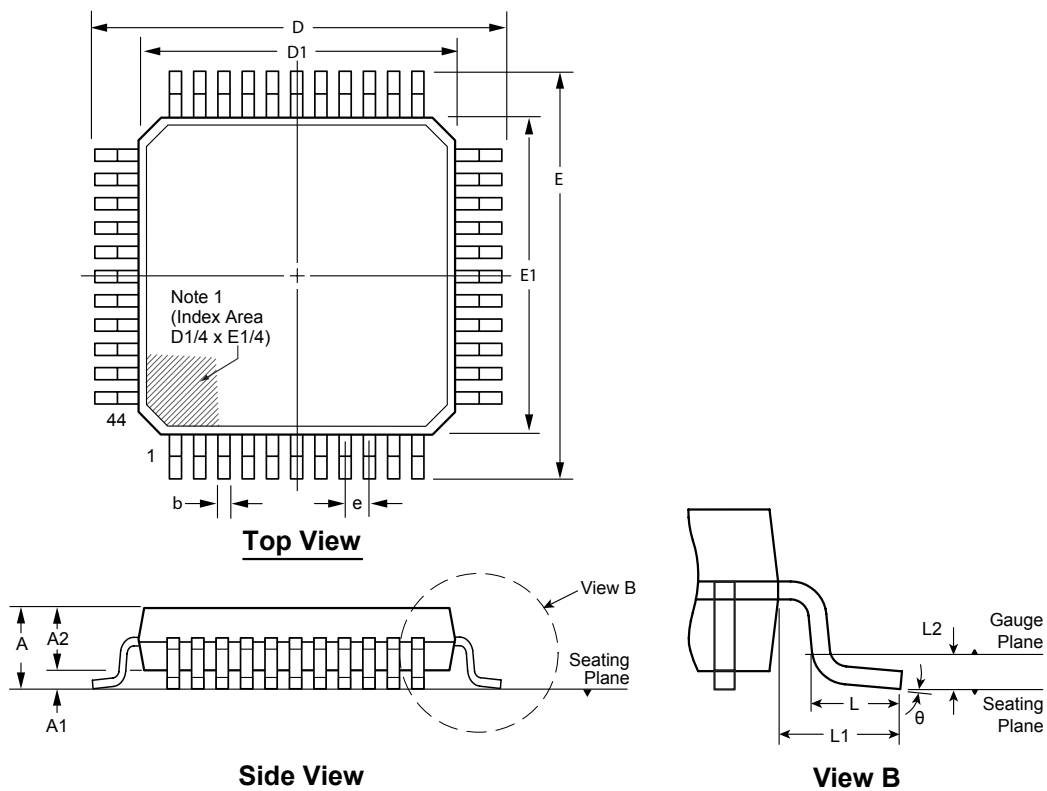

Note: For the most current package drawings, see the Microchip Packaging Specification at [www.microchip.com/packaging](http://www.microchip.com/packaging).

**Note:**

1. A Pin 1 identifier must be located in the index area indicated. The Pin 1 identifier can be: a molded mark/identifier; an embedded metal marker; or a printed indicator.

Symbol	A	A1	A2	b	D	D1	E	E1	e	L	L1	L2	θ	
Dimension (mm)	MIN	1.95*	0.00	1.95	0.30	13.65*	9.80*	13.65*	9.80*	0.80 BSC	1.95 REF	0.25 BSC	0°	
	NOM	-	-	2.00	-	13.90	10.00	13.90	10.00				0.88	3.5°
	MAX	2.35	0.25	2.10	0.45	14.15*	10.20*	14.15*	10.20*				1.03	7°

JEDEC Registration MO-112, Variation AA-2, Issue B, Sep.1995.

\* This dimension is not specified in the JEDEC drawing.

Drawings not to scale.

---



---

## Package Outlines and Dimensions

---



---

### 64-Lead PQFP (3-Sided) Package Outline (PG)

20.00x14.00mm body, 3.40mm height (max), 0.80mm pitch, 3.90mm footprint

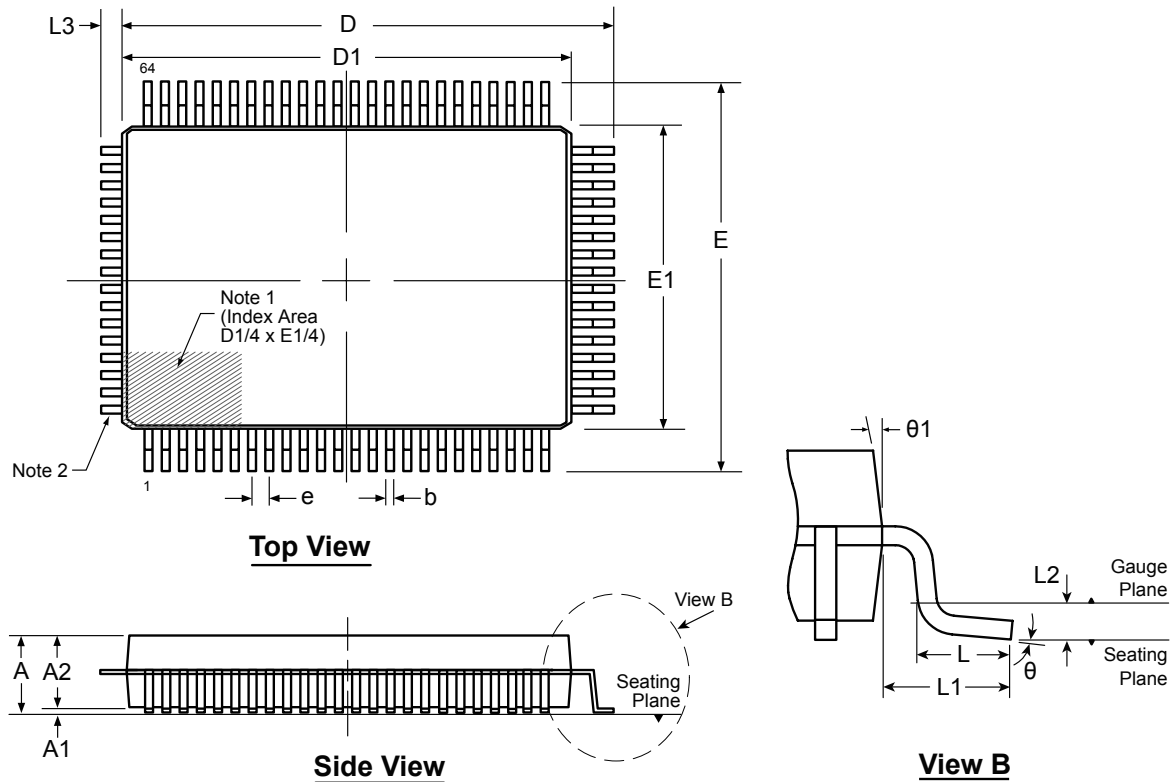

Note: For the most current package drawings, see the Microchip Packaging Specification at [www.microchip.com/packaging](http://www.microchip.com/packaging).

**Note:**

1. A Pin 1 identifier must be located in the index area indicated. The Pin 1 identifier can be: a molded mark/identifier; an embedded metal marker; or a printed indicator.
2. The leads on this side are trimmed.

Symbol	A	A1	A2	b	D	D1	E	E1	e	L	L1	L2	L3	$\theta$	$\theta 1$	
Dimension (mm)	MIN	2.80	0.25	2.55	0.30	22.25	19.80	17.65	13.80	0.80 BSC	0.73	1.95 REF	0.25 BSC	0.55 REF	0°	5°
	NOM	-	-	2.80	-	22.50	20.00	17.90	14.00		0.88				3.5°	-
	MAX	3.40	0.50	3.05	0.45	22.75	20.20	18.15	14.20		1.03				7°	16°

Drawings not to scale.

Supertex Doc. #: DSPD-64PQFP, Version NR090608.

## Package Outlines and Dimensions

### 80-Lead PQFP Package Outline (PG)

20.00x14.00mm body, 3.40mm height (max), 0.80mm pitch, 3.90mm footprint

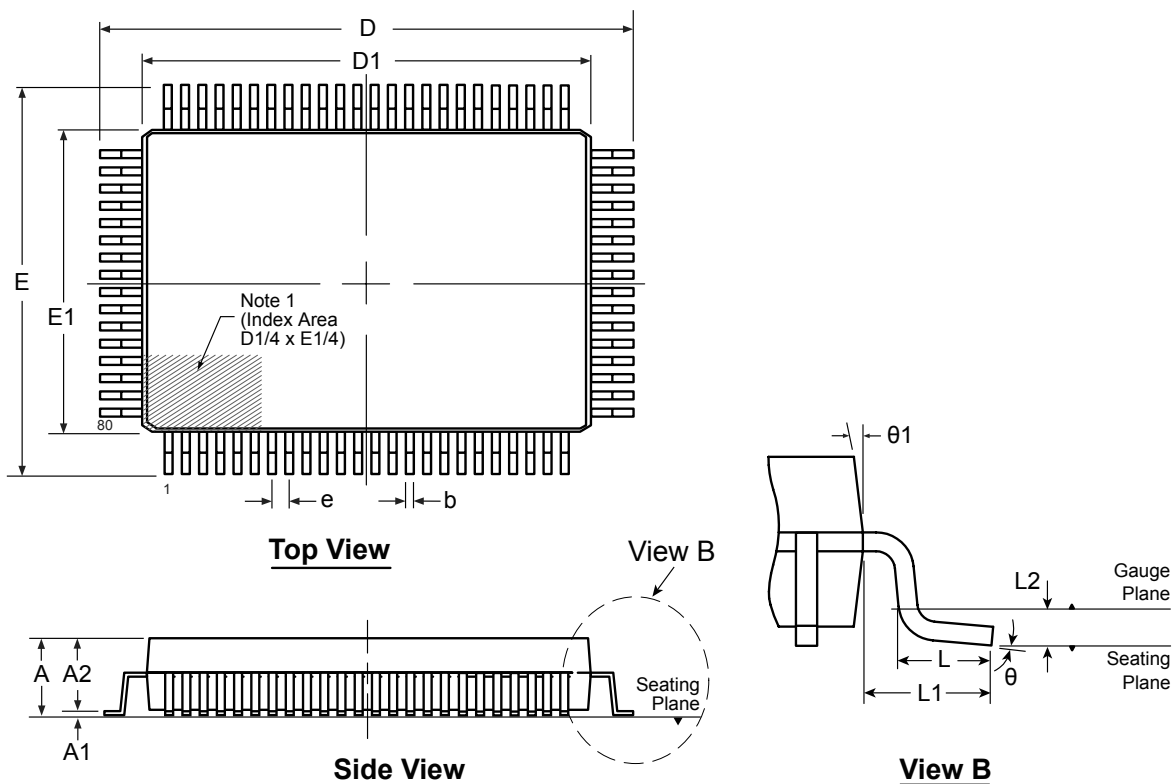

Note: For the most current package drawings, see the Microchip Packaging Specification at [www.microchip.com/packaging](http://www.microchip.com/packaging).

**Note:**

1. A Pin 1 identifier must be located in the index area indicated. The Pin 1 identifier can be: a molded mark/identifier; an embedded metal marker; or a printed indicator.

Symbol	A	A1	A2	b	D	D1	E	E1	e	L	L1	L2	θ	θ1	
Dimension (mm)	MIN	2.80*	0.25	2.55	0.30	23.65*	19.80*	17.65*	13.80*	0.80 BSC	0.73	1.95 REF	0.25 BSC	0°	5°
	NOM	-	-	2.80	-	23.90	20.00	17.90	14.00		0.88			3.5°	-
	MAX	3.40	0.50*	3.05	0.45	24.15*	20.20*	18.15*	14.20*		1.03			7°	16°

JEDEC Registration MO-112, Variation CB-1, Issue B, Sept. 1995.

\* This dimension is not specified in the JEDEC drawing.

Drawings not to scale.

S D # DSPD 80PQFPFG V i C041309



## Package Outlines and Dimensions

### 100-Lead PQFP Package Outline (PG)

20.00x14.00mm body, 3.40mm height (max), 0.65mm pitch, 3.90mm footprint

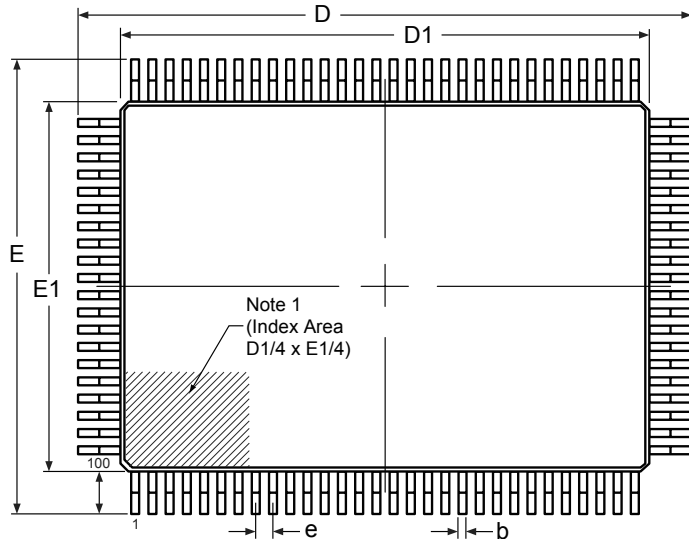

**Top View**

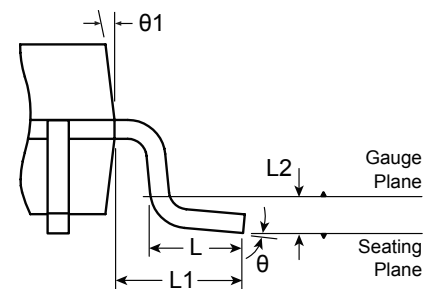

**View B**



**Side View**

Note: For the most current package drawings, see the Microchip Packaging Specification at [www.microchip.com/packaging](http://www.microchip.com/packaging).

**Note:**

- A Pin 1 identifier must be located in the index area indicated. The Pin 1 identifier can be: a molded mark/identifier; an embedded metal marker; or a printed indicator.

Symbol	A	A1	A2	b	D	D1	E	E1	e	L	L1	L2	$\theta$	$\theta 1$	
Dimension (mm)	MIN	2.80*	0.25	2.55	0.22	23.65*	19.80*	17.65*	13.80*	0.65 BSC	0.73	1.95 REF	0.25 BSC	0	5°
	NOM	-	-	2.80	-	23.90	20.00	17.90	14.00		0.88			3.5°	-
	MAX	3.40	0.50*	3.05	0.38	24.15*	20.20*	18.15*	14.20*		1.03			7°	16°

JEDEC Registration MO-112, Variation CC-1, Issue B, Sept. 1995.

\* This dimension is not specified in the JEDEC drawing.

Drawings are not to scale.

S D # DSPD 100PQFP V i C111109



**MICROCHIP**

---

---

**Package Outlines and Dimensions**

---

---

NOTES:

---

---

**Package Outlines and Dimensions**

---

---

**QFN**

Supertex Legacy

**Package Outlines and Dimensions**

**16-Lead QFN Package Outline (K6)**  
**4.00x4.00mm body, 1.00mm height (max), 0.65mm pitch**

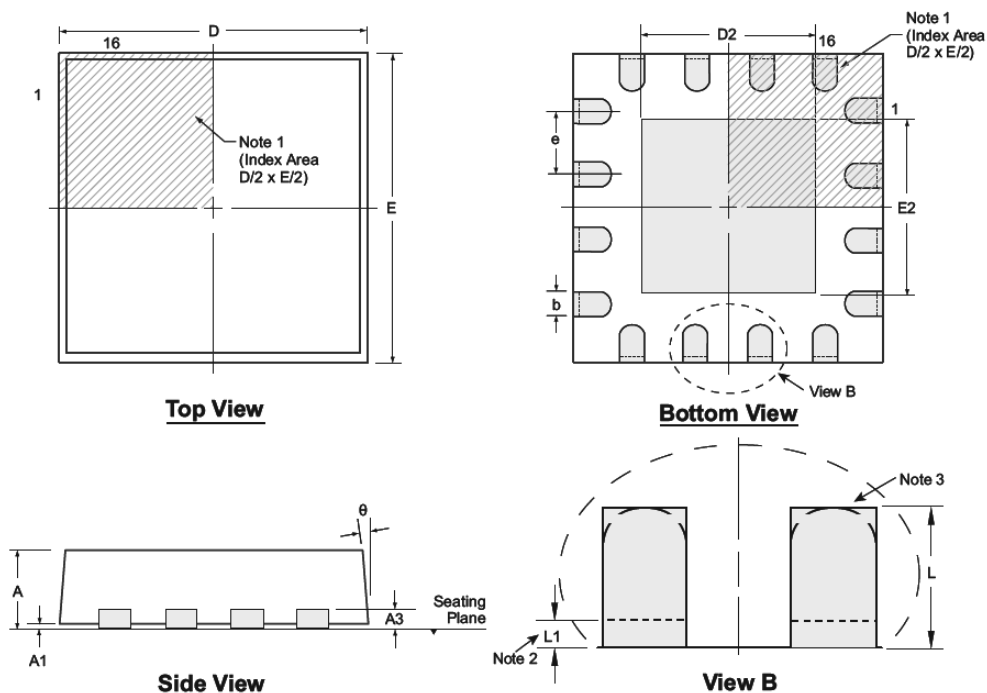

Note: For the most current package drawings, see the Microchip Packaging Specification at [www.microchip.com/packaging](http://www.microchip.com/packaging).

**Notes:**

1. A Pin 1 identifier must be located in the index area indicated. The Pin 1 identifier can be: a molded mark/identifier; an embedded metal marker; or a printed indicator.
2. Depending on the method of manufacturing, a maximum of 0.15mm pullback ( $L1$ ) may be present.
3. The inner tip of the lead may be either rounded or square.

Symbol	A	A1	A3	b	D	D2	E	E2	e	L	L1	$\theta$	
Dimension (mm)	MIN	0.80	0.00	0.20 REF	0.25	3.85*	2.50	3.85*	2.50	0.65 BSC	0.30 <sup>†</sup>	0.00	0°
	NOM	0.90	0.02		0.30	4.00	2.65	4.00	2.65		0.40 <sup>†</sup>	-	-
	MAX	1.00	0.05		0.35	4.15*	2.80	4.15*	2.80		0.50 <sup>†</sup>	0.15	14°

JEDEC Registration MO-220, Variation VGGC-2, Issue K, June 2006.

\* This dimension is not specified in the JEDEC drawing.

† This dimension differs from the JEDEC drawing.

Drawings not to scale.

---



---

## Package Outlines and Dimensions

---



---

### 24-Lead QFN Package Outline (K6)

**4.00x4.00mm body, 1.00mm height (max), 0.50mm pitch**

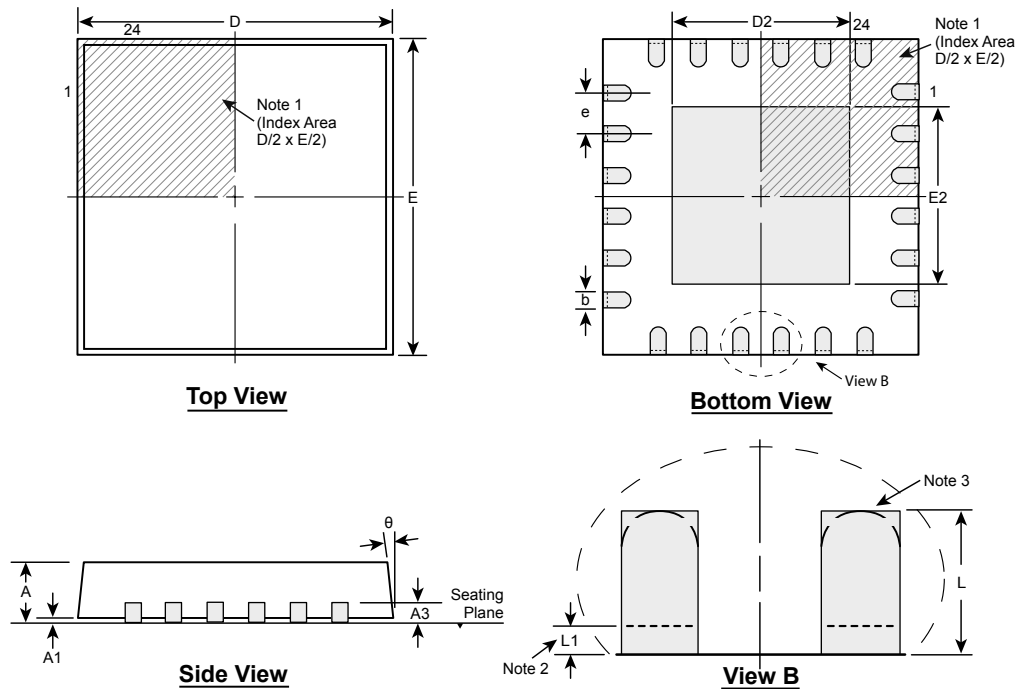

Note: For the most current package drawings, see the Microchip Packaging Specification at [www.microchip.com/packaging](http://www.microchip.com/packaging).

**Notes:**

1. A Pin 1 identifier must be located in the index area indicated. The Pin 1 identifier can be: a molded mark/identifier; an embedded metal marker; or a printed indicator.
2. Depending on the method of manufacturing, a maximum of 0.15mm pullback (L1) may be present.
3. The inner tip of the lead may be either rounded or square.

Symbol	A	A1	A3	b	D	D2	E	E2	e	L	L1	$\theta$	
Dimension (mm)	MIN	0.80	0.00	0.20 REF	0.18	3.85	2.55	3.85	2.55	0.50 BSC	0.25	0.03	0°
	NOM	0.90	0.02		0.25	4.00	2.70	4.00	2.70		0.35	-	-
	MAX	1.00	0.05		0.30	4.15	2.80	4.15	2.80		0.45	0.15	14°

*Drawings not to scale.*

**Package Outlines and Dimensions**

**12-Lead QFN Package Outline (K6)**

4.00x4.00mm body, 1.00mm height (max), 0.80mm pitch

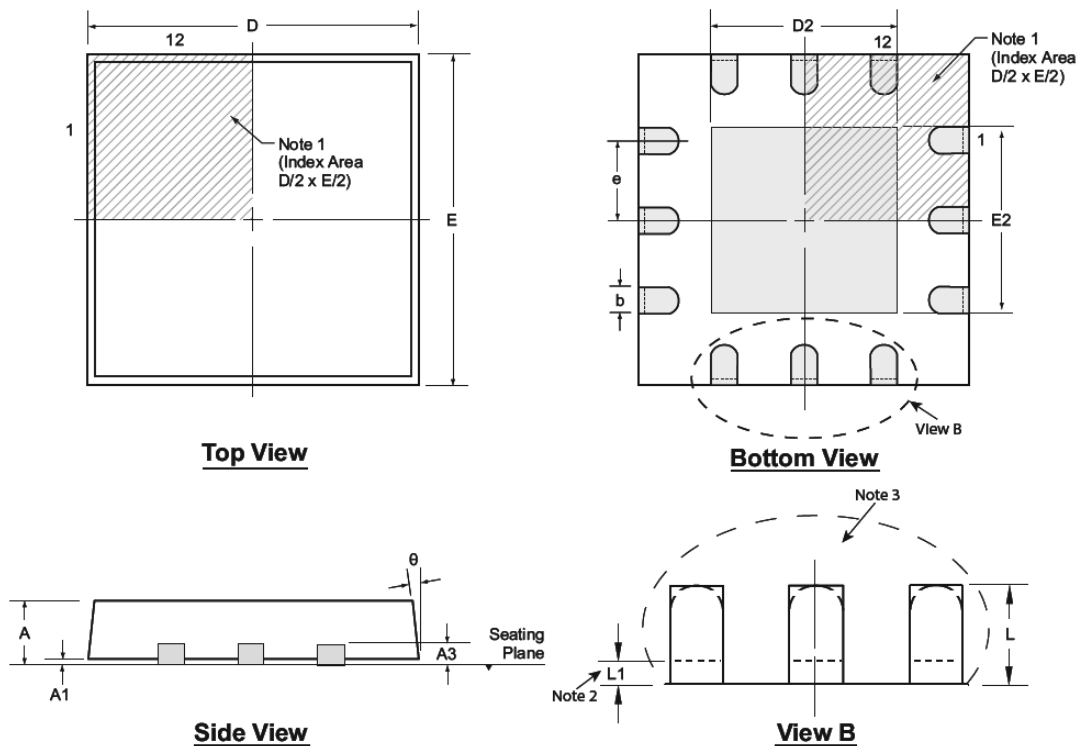

Note: For the most current package drawings, see the Microchip Packaging Specification at [www.microchip.com/packaging](http://www.microchip.com/packaging).

**Notes:**

1. A Pin 1 identifier must be located in the index area indicated. The Pin 1 identifier can be: a molded mark/identifier; an embedded metal marker; or a printed indicator.
2. Depending on the method of manufacturing, a maximum of 0.15mm pullback ( $L1$ ) may be present.
3. The inner tip of the lead may be either rounded or square.

Symbol	A	A1	A3	b	D	D2	E	E2	e	L	L1	$\theta$	
Dimension (mm)	MIN	0.80	0.00	0.20 REF	0.25	3.85*	0.75	3.85*	0.75	0.80 BSC	0.35	0.00	0°
	NOM	0.90	0.02		0.30	4.00	1.70	4.00	1.70		0.55	-	-
	MAX	1.00	0.05		0.35	4.15*	2.25	4.15*	2.25		0.75	0.15	14°

JEDEC Registration MO-220, Variation VGGB, Issue K, June 2006.

\* This dimension is not specified in the JEDEC drawing.

Drawings not to scale.

---



---

## Package Outlines and Dimensions

---



---

### 14-Lead QFN Package Outline (K6)

**5.00x5.00mm body, 1.00mm height (max), 1.27mm pitch**

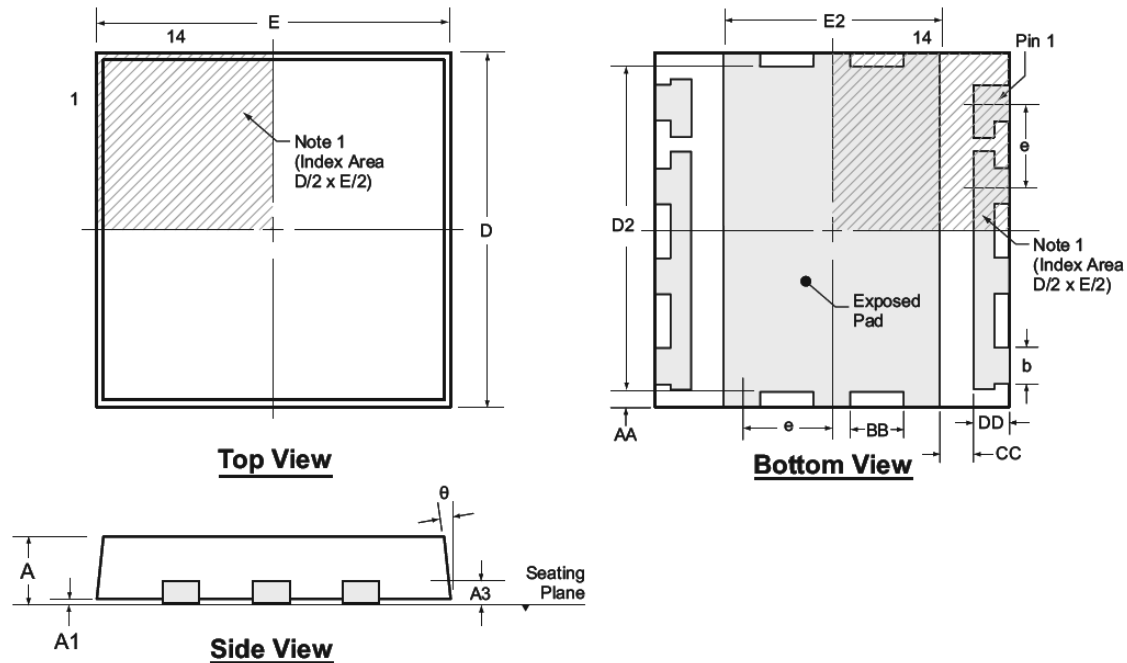

Note: For the most current package drawings, see the Microchip Packaging Specification at [www.microchip.com/packaging](http://www.microchip.com/packaging).

**Notes:**

1. A Pin 1 identifier must be located in the index area indicated. The Pin 1 identifier can be: a molded mark/identifier; an embedded metal marker; or a printed indicator.

Symbol	A	A1	A3	b	D	D2	E	E2	e	AA	BB	CC	DD	$\theta$	
Dimension (mm)	MIN	0.80	0.00	0.20 REF	0.46	4.85	4.45	4.85	2.52	1.27 BSC	0.152	0.473	0.66	0.456	0°
	NOM	0.90	0.02		0.51	5.00	4.50	5.00	2.57		0.252	0.523	0.71	0.506	-
	MAX	1.00	0.05		0.58	5.15	4.55	5.15	2.62		0.352	0.583	0.77	0.566	14°

Drawings not to scale.

**Package Outlines and Dimensions**

**16-Lead QFN Package Outline (K6)**  
**3.00x3.00mm body, 1.00mm height (max), 0.50mm pitch**

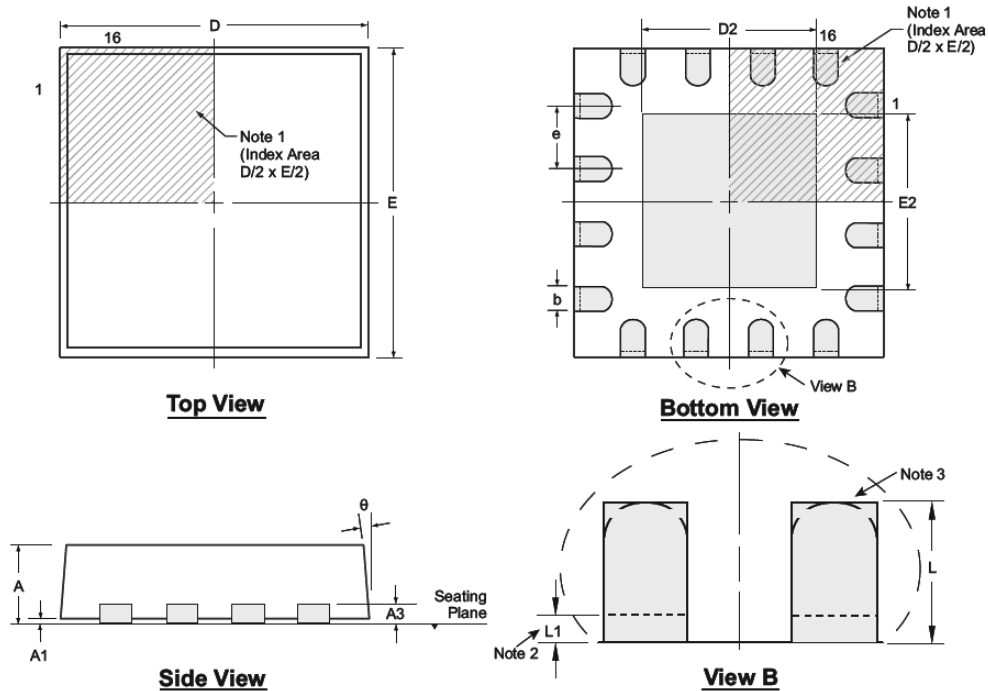

Note: For the most current package drawings, see the Microchip Packaging Specification at [www.microchip.com/packaging](http://www.microchip.com/packaging).

**Notes:**

1. A Pin 1 identifier must be located in the index area indicated. The Pin 1 identifier can be: a molded mark/identifier, an embedded metal marker, or a printed indicator.
2. Depending on the method of manufacturing, a maximum of 0.15mm pullback ( $L1$ ) may be present.
3. The inner tip of the lead may be either rounded or square.

Symbol	A	A1	A3	b	D	D2	E	E2	e	L	L1	$\theta$	
Dimension (mm)	MIN	0.80	0.00	0.20 REF	0.18	2.85*	1.50	2.85*	1.50	0.50 BSC	0.20†	0.00	0°
	NOM	0.90	0.02		0.25	3.00	1.65	3.00	1.65		0.30†	-	-
	MAX	1.00	0.05		0.30	3.15*	1.80	3.15*	1.80		0.45	0.15	14°

JEDEC Registration MO-220, Variation VEED-4, Issue K, June 2006.

\* This dimension is not specified in the JEDEC drawing.

† This dimension differs from the JEDEC drawing.

**Drawings not to scale.**



---



---

## Package Outlines and Dimensions

---



---

### 16-Lead QFN Package Outline (K6)

**4.00x4.00mm body, 1.00mm height (max), 0.65mm pitch**

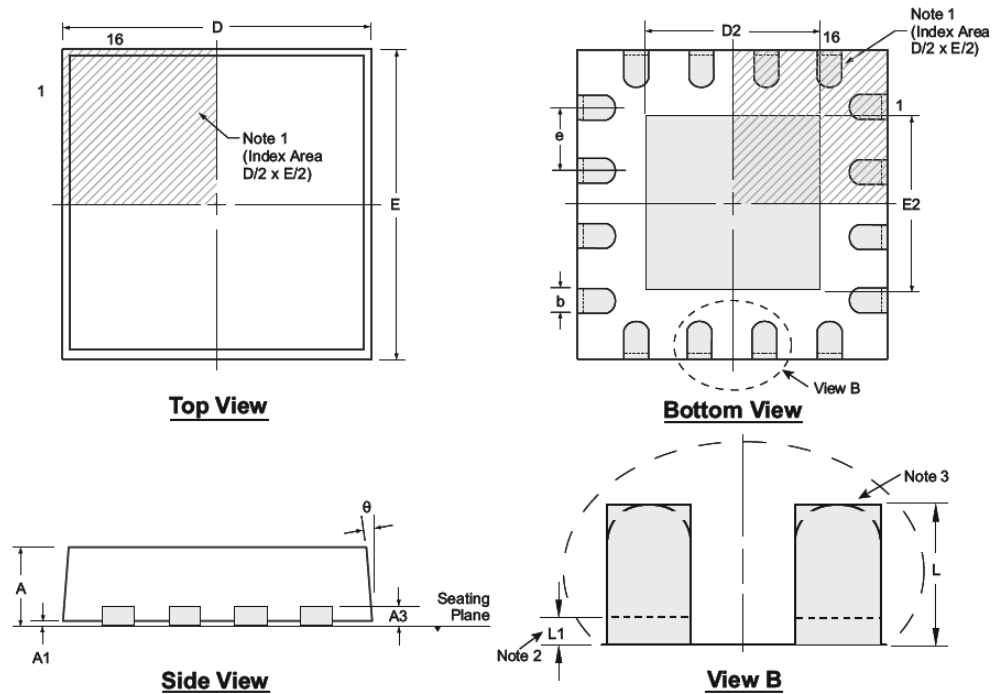

Note: For the most current package drawings, see the Microchip Packaging Specification at [www.microchip.com/packaging](http://www.microchip.com/packaging).

**Notes:**

1. A Pin 1 identifier must be located in the index area indicated. The Pin 1 identifier can be: a molded mark/identifier, an embedded metal marker, or a printed indicator.
2. Depending on the method of manufacturing, a maximum of 0.15mm pullback (L1) may be present.
3. The inner tip of the lead may be either rounded or square.

Symbol	A	A1	A3	b	D	D2	E	E2	e	L	L1	$\theta$	
Dimension (mm)	MIN	0.80	0.00	0.20 REF	0.25	3.85*	2.50	3.85*	2.50	0.65 BSC	0.30 <sup>†</sup>	0.00	0°
	NOM	0.90	0.02		0.30	4.00	2.65	4.00	2.65		0.40 <sup>†</sup>	-	-
	MAX	1.00	0.05		0.35	4.15*	2.80	4.15*	2.80		0.50 <sup>†</sup>	0.15	14°

JEDEC Registration MO-220, Variation VGGC-2, Issue K, June 2006.

\* This dimension is not specified in the JEDEC drawing.

† This dimension differs from the JEDEC drawing.

Drawings not to scale.

**Package Outlines and Dimensions**

**24-Lead QFN Package Outline (K6)**

4.00x5.00mm body, 1.00mm height (max), 0.50mm pitch

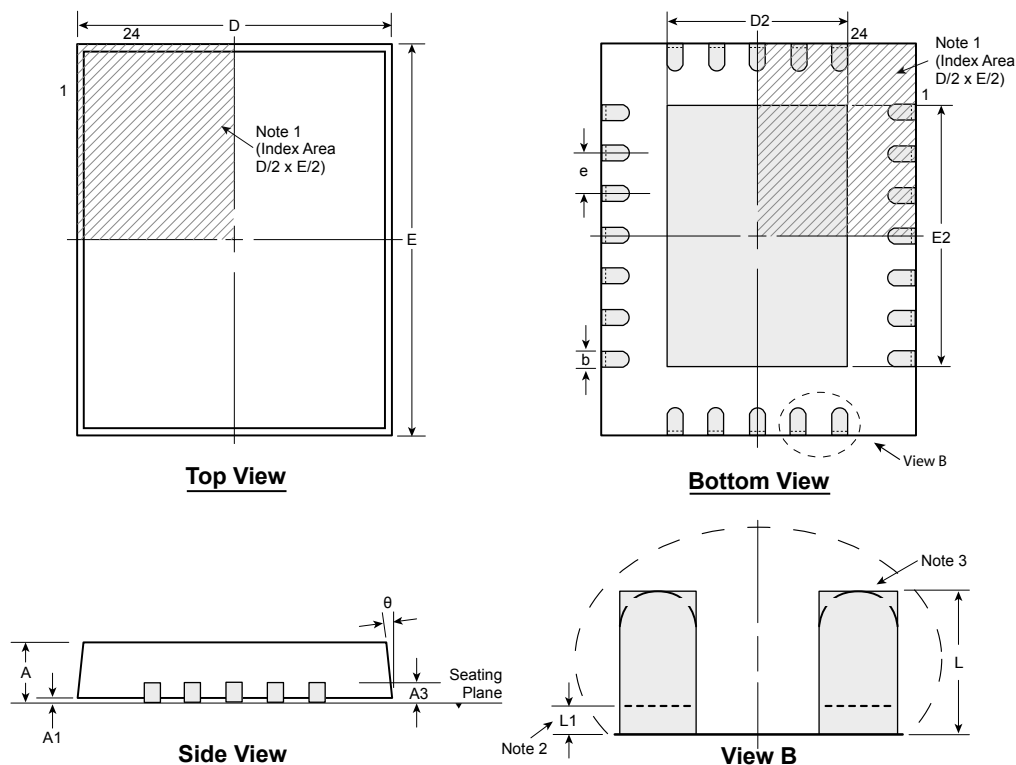

Note: For the most current package drawings, see the Microchip Packaging Specification at [www.microchip.com/packaging](http://www.microchip.com/packaging).

**Notes:**

1. A Pin 1 identifier must be located in the index area indicated. The Pin 1 identifier can be: a molded mark/identifier; an embedded metal marker; or a printed indicator.
2. Depending on the method of manufacturing, a maximum of 0.15mm pullback (L1) may be present.
3. The inner tip of the lead may be either rounded or square.

Symbol	A	A1	A3	b	D	D2	E	E2	e	L	L1	θ	
Dimension (mm)	MIN	0.80	0.00	0.20 REF	0.18	3.85*	2.50	4.85*	3.50	0.50 BSC	±0.30	0.00	0°
	NOM	0.90	0.02		0.25	4.00	2.65	5.00	3.65		0.40	-	-
	MAX	1.00	0.05		0.30	4.15*	2.80	5.15*	3.80		±0.50	0.15	14°

JEDEC Registration MO-220, Variation VGHD-1, Issue K, June 2006

\* This dimension is not specified in the JEDEC drawing.

† This dimension differs from the JEDEC drawing.

Drawings not to scale.

---



---

## Package Outlines and Dimensions

---



---

### 32-Lead QFN Package Outline (K6)

**5.00x5.00mm body, 1.00mm height (max), 0.50mm pitch**

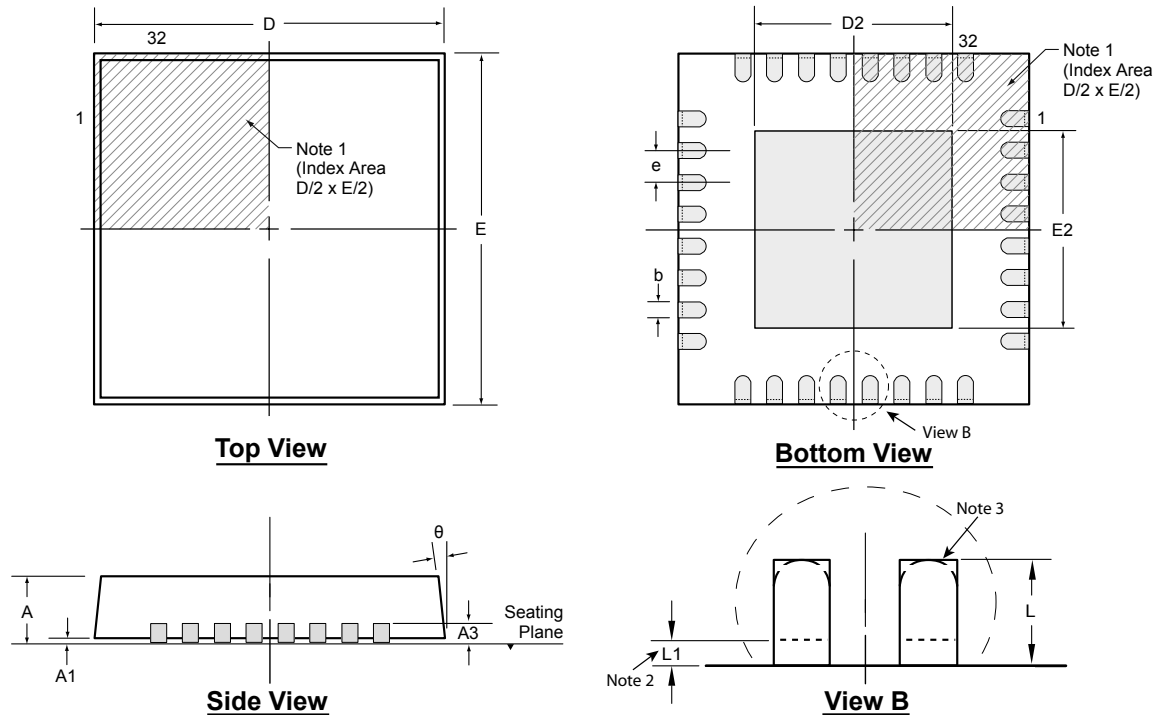

Note: For the most current package drawings, see the Microchip Packaging Specification at [www.microchip.com/packaging](http://www.microchip.com/packaging).

**Notes:**

1. A Pin 1 identifier must be located in the index area indicated. The Pin 1 identifier can be: a molded mark/identifier; an embedded metal marker; or a printed indicator.
2. Depending on the method of manufacturing, a maximum of 0.15mm pullback (L1) may be present.
3. The inner tip of the lead may be either rounded or square.

Symbol	A	A1	A3	b	D	D2	E	E2	e	L	L1	θ	
Dimension (mm)	MIN	0.80	0.00	0.20 REF	0.18	4.85*	1.05	4.85*	1.05	0.50 BSC	0.30 <sup>†</sup>	0.00	0°
	NOM	0.90	0.02		0.25	5.00	-	5.00	-		0.40 <sup>†</sup>	-	-
	MAX	1.00	0.05		0.30	5.15*	3.55 <sup>†</sup>	5.15*	3.55 <sup>†</sup>		0.50 <sup>†</sup>	0.15	14°

JEDEC Registration MO-220, Variation VHHD-6, Issue K, June 2006.

\* This dimension is not specified in the JEDEC drawing.

† This dimension differs from the JEDEC drawing.

Drawings not to scale.

**Package Outlines and Dimensions**

**33-Lead QFN Package Outline (K6)**

**6.00x6.00mm body, 1.00mm height (max), 0.50mm pitch**

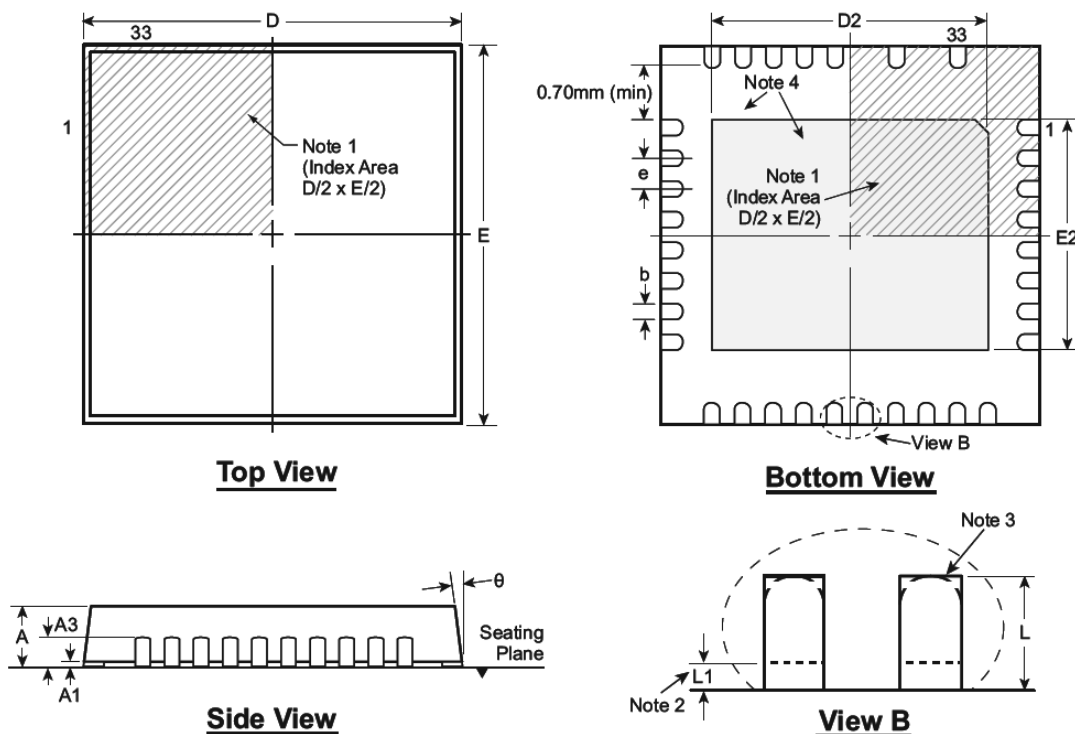

Note: For the most current package drawings, see the Microchip Packaging Specification at [www.microchip.com/packaging](http://www.microchip.com/packaging).

**Notes:**

1. A Pin 1 identifier must be located in the index area indicated. The Pin 1 identifier can be: a molded mark/identifier; an embedded metal marker; or a printed indicator.
2. Depending on the method of manufacturing, a maximum of 0.15mm pullback (L1) may be present.
3. The inner tip of the lead may be either rounded or square.
4. There will be an exposed DAP. A minimum of 0.7mm spacing will be maintained between the leads and the DAP.

Symbol	A	A1	A3	b	D	D2	E	E2	e	L	L1	$\theta^\circ$	
Dimension (mm)	MIN	0.80	0.00	0.20 REF	0.18	5.85	4.00	5.85	3.60	0.50 BSC	0.30	0.00	0
	NOM	0.90	0.02		0.25	6.00	4.15	6.00	3.75		0.40	-	-
	MAX	1.00	0.05		0.30	6.15	4.25	6.15	3.85		0.50	0.15	14

Drawings not to scale.

---



---

## Package Outlines and Dimensions

---



---

### 40-Lead QFN Package Outline (K6)

**6.00x6.00mm body, 1.00mm height (max), 0.50mm pitch**

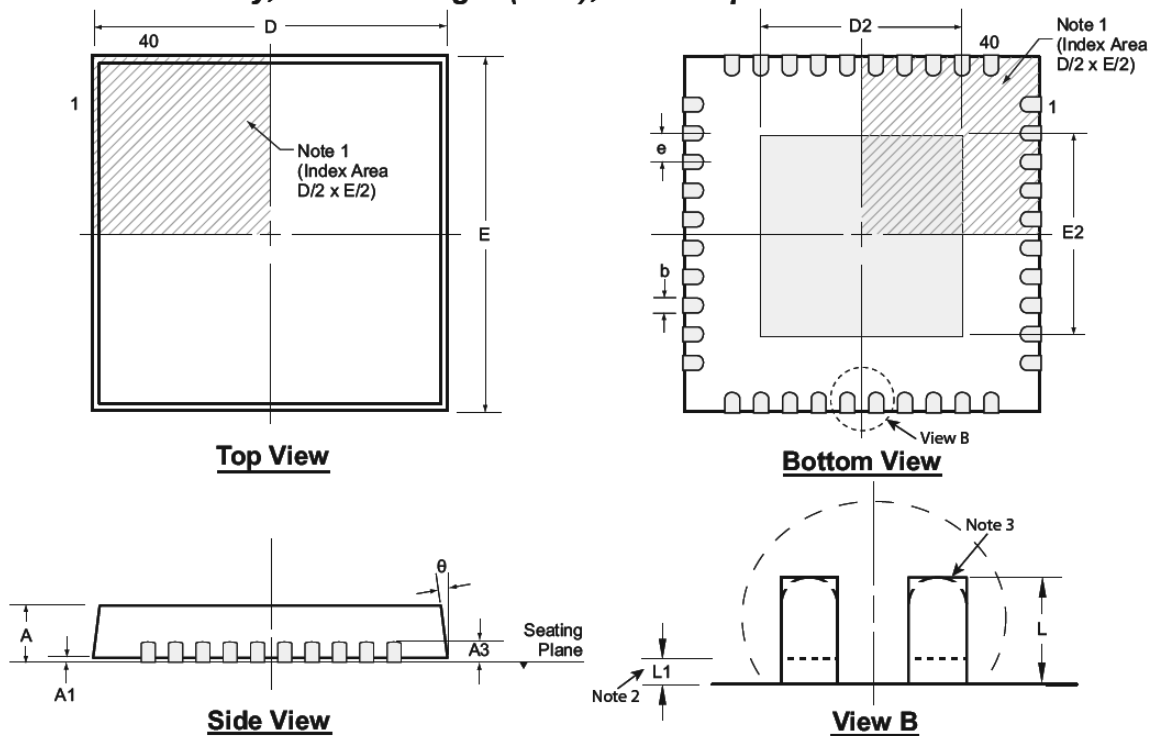

Note: For the most current package drawings, see the Microchip Packaging Specification at [www.microchip.com/packaging](http://www.microchip.com/packaging).

**Notes:**

1. A Pin 1 identifier must be located in the index area indicated. The Pin 1 identifier can be: a molded mark/identifier, an embedded metal marker, or a printed indicator.
2. Depending on the method of manufacturing, a maximum of 0.15mm pullback ( $L1$ ) may be present.
3. The inner tip of the lead may be either rounded or square.

Symbol	A	A1	A3	b	D	D2	E	E2	e	L	L1	$\theta^\circ$	
Dimension (mm)	MIN	0.80	0.00	0.20 REF	0.18	5.85*	1.05	5.85*	1.05	0.50 BSC	0.30 <sup>†</sup>	0.00	0
	NOM	0.90	0.02		0.25	6.00	-	6.00	-		0.40 <sup>†</sup>	-	-
	MAX	1.00	0.05		0.30	6.15*	4.45	6.15*	4.45		0.50 <sup>†</sup>	0.15	14

JEDEC Registration MO-220, Variation VJJD-6, Issue K, June 2006.

\* This dimension is not specified in the JEDEC drawing.

† This dimension differs from the JEDEC drawing.

**Drawings not to scale.**

**Package Outlines and Dimensions**

**48-Lead QFN Package Outline (K6)**

*7.00x7.00mm body, 1.00mm height (max), 0.50mm pitch*

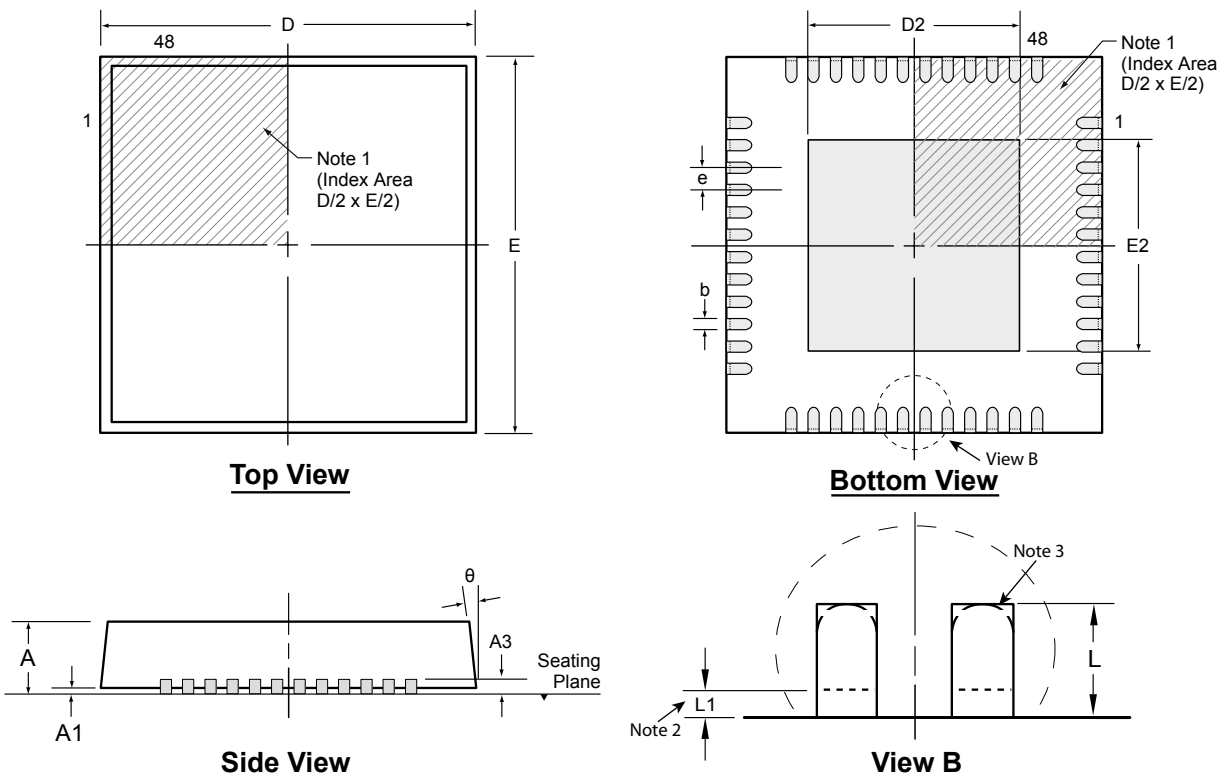

Note: For the most current package drawings, see the Microchip Packaging Specification at [www.microchip.com/packaging](http://www.microchip.com/packaging).

**Notes:**

1. A Pin 1 identifier must be located in the index area indicated. The Pin 1 identifier can be: a molded mark/identifier; an embedded metal marker; or a printed indicator.
2. Depending on the method of manufacturing, a maximum of 0.15mm pullback (L1) may be present.
3. The inner tip of the lead may be either rounded or square.

Symbol	A	A1	A3	b	D	D2	E	E2	e	L	L1	θ	
Dimension (mm)	MIN	0.80	0.00	0.20 REF	0.18	6.85*	1.25	6.85*	1.25	0.50 BSC	0.30†	0.00	0°
	NOM	0.90	0.02		0.25	7.00	-	7.00	-		0.40†	-	-
	MAX	1.00	0.05		0.30	7.15*	5.45	7.15*	5.45		0.50†	0.15	14°

JEDEC Registration MO-220, Variation VKKD-6, Issue K, June 2006.

\* This dimension is not specified in the JEDEC drawing.

† This dimension differs from the JEDEC drawing.

**Drawings are not to scale.**

---



---

## Package Outlines and Dimensions

---



---

### 56-Lead QFN Package Outline (K6)

8.00x8.00mm body, 1.00mm height (max), 0.50mm pitch

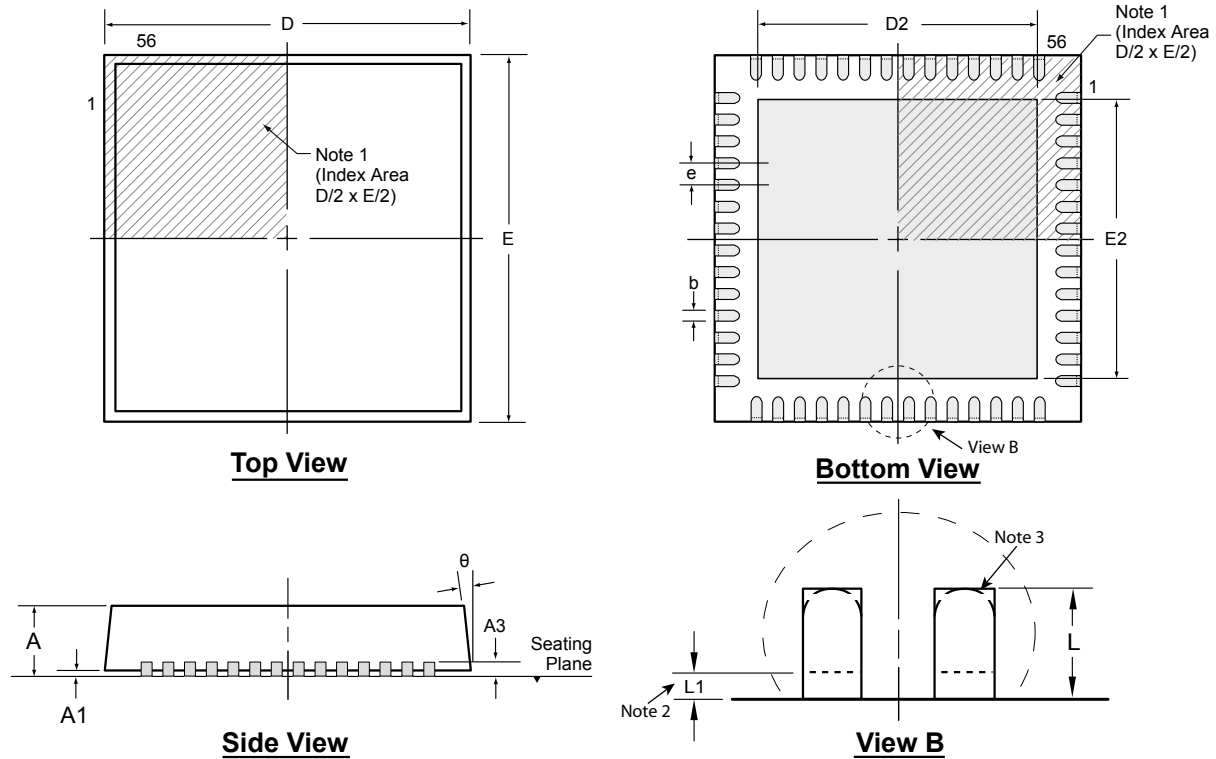

Note: For the most current package drawings, see the Microchip Packaging Specification at [www.microchip.com/packaging](http://www.microchip.com/packaging).

**Notes:**

1. A Pin 1 identifier must be located in the index area indicated. The Pin 1 identifier can be: a molded mark/identifier; an embedded metal marker; or a printed indicator.
2. Depending on the method of manufacturing, a maximum of 0.15mm pullback (L1) may be present.
3. The inner tip of the lead may be either rounded or square.

Symbol	A	A1	A3	b	D	D2	E	E2	e	L	L1	$\theta$	
Dimension (mm)	MIN	0.80	0.00	0.20 REF	0.18	7.85*	2.75	7.85*	2.75	0.50 BSC	0.30	0.00	0°
	NOM	0.90	0.02		0.25	8.00	5.70	8.00	5.70		0.40	-	-
	MAX	1.00	0.05		0.30	8.15*	6.70†	8.15*	6.70†		0.50	0.15	14°

JEDEC Registration MO-220, Variation VLLD-2, Issue K, June 2006.

\* This dimension is not specified in the JEDEC drawing.

† This dimension differs from the JEDEC drawing.

Drawings are not to scale.

**Package Outlines and Dimensions**

**64-Lead QFN Package Outline (K6)**  
**9.00x9.00mm body, 1.00mm height (max), 0.50mm pitch**

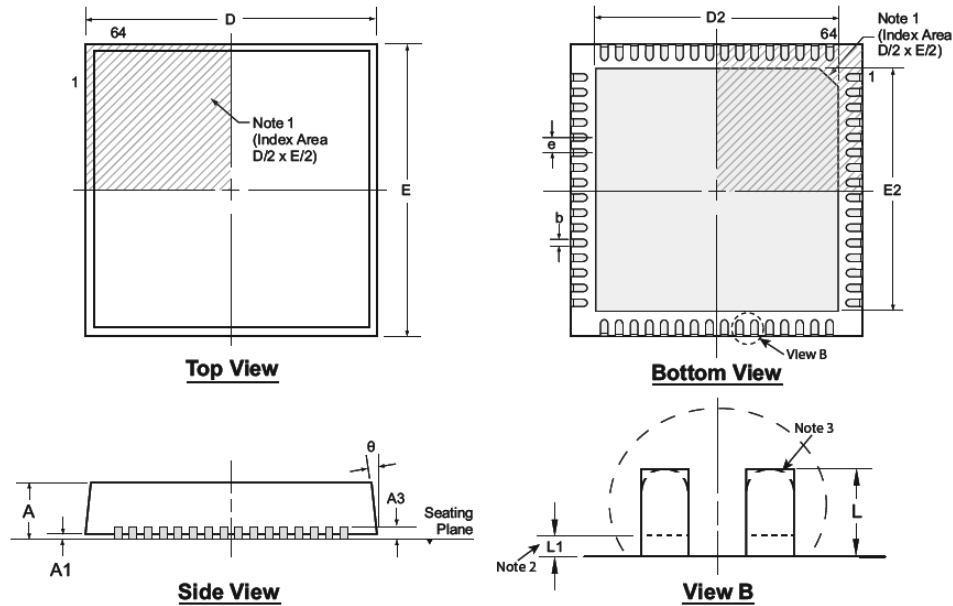

Note: For the most current package drawings, see the Microchip Packaging Specification at [www.microchip.com/packaging](http://www.microchip.com/packaging).

**Notes:**

1. A Pin 1 identifier must be located in the index area indicated. The Pin 1 identifier can be: a molded mark/identifier, an embedded metal marker, or a printed indicator.
2. Depending on the method of manufacturing, a maximum of 0.15mm pullback ( $L1$ ) may be present.
3. The inner tip of the lead may be either rounded or square.

Symbol	A	A1	A3	b	D	D2	E	E2	e	L	L1	$\theta$	
Dimension (mm)	MIN	0.80	0.00	0.20 REF	0.18	8.85*	6.00	8.85*	6.00	0.50 BSC	0.30	0.00	0°
	NOM	0.90	0.02		0.25	9.00	7.70*	9.00	7.70*		0.40	-	-
	MAX	1.00	0.05		0.30	9.15*	7.80†	9.15*	7.80†		0.50	0.15	14°

JEDEC Registration MO-220, Variation VMMD-4, Issue K, June 2006.

\* This dimension is not specified in the JEDEC drawing.

† This dimension differs from the JEDEC drawing.

Drawings are not to scale.



## Package Outlines and Dimensions

### 80-Lead QFN Package Outline (K6)

*11.00x11.00mm body, 1.00mm height (max), 0.50mm pitch*

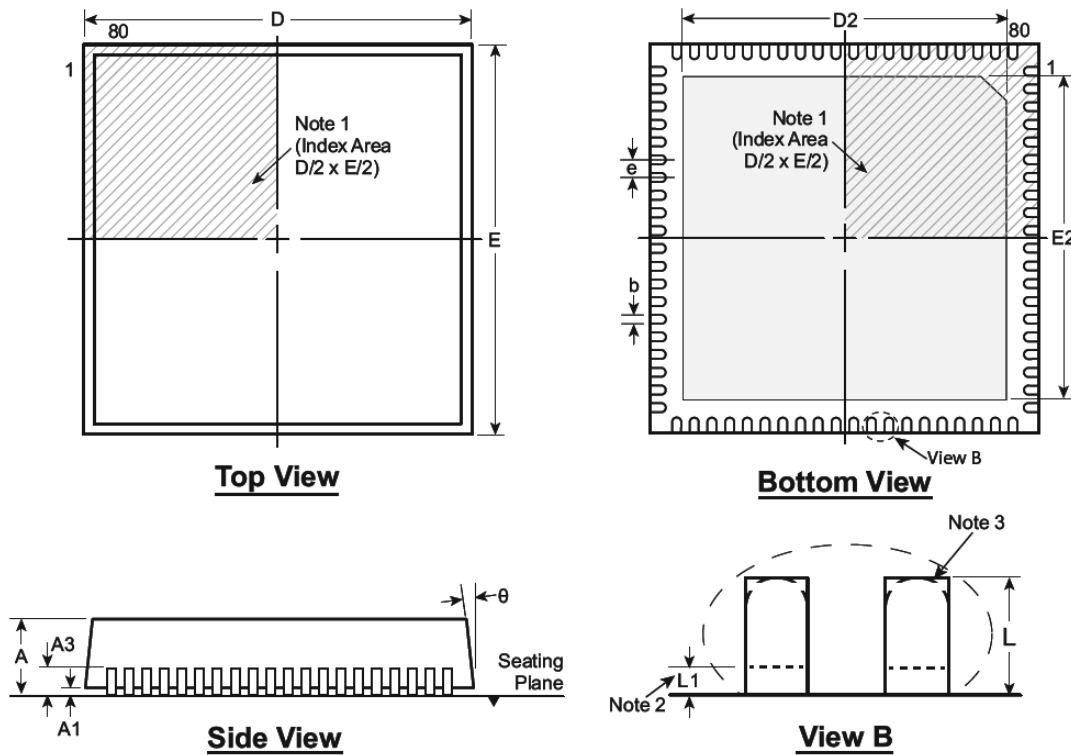

Note: For the most current package drawings, see the Microchip Packaging Specification at [www.microchip.com/packaging](http://www.microchip.com/packaging).

**Notes:**

1. A Pin 1 identifier must be located in the index area indicated. The Pin 1 identifier can be: a molded mark/identifier; an embedded metal marker; or a printed indicator.
2. Depending on the method of manufacturing, a maximum of 0.15mm pullback (L1) may be present.
3. The inner tip of the lead may be either rounded or square.

Symbol	A	A1	A3	b	D	D2	E	E2	e	L	L1	$\theta$	
Dimension (mm)	MIN	0.80	0.00	0.20 REF	0.18	10.90	9.50	10.90	9.50	0.50 BSC	0.30	0.00	0°
	NOM	0.90	0.02		0.25	11.00	9.65	11.00	9.65		0.40	-	-
	MAX	1.00	0.05		0.30	11.10	9.75	11.10	9.75		0.50	0.15	14°

*Drawings are not to scale.*

**Package Outlines and Dimensions**

**12-Lead QFN Package Outline (K7)**

**3.00x3.00mm body, 0.80mm height (max), 0.50mm pitch**

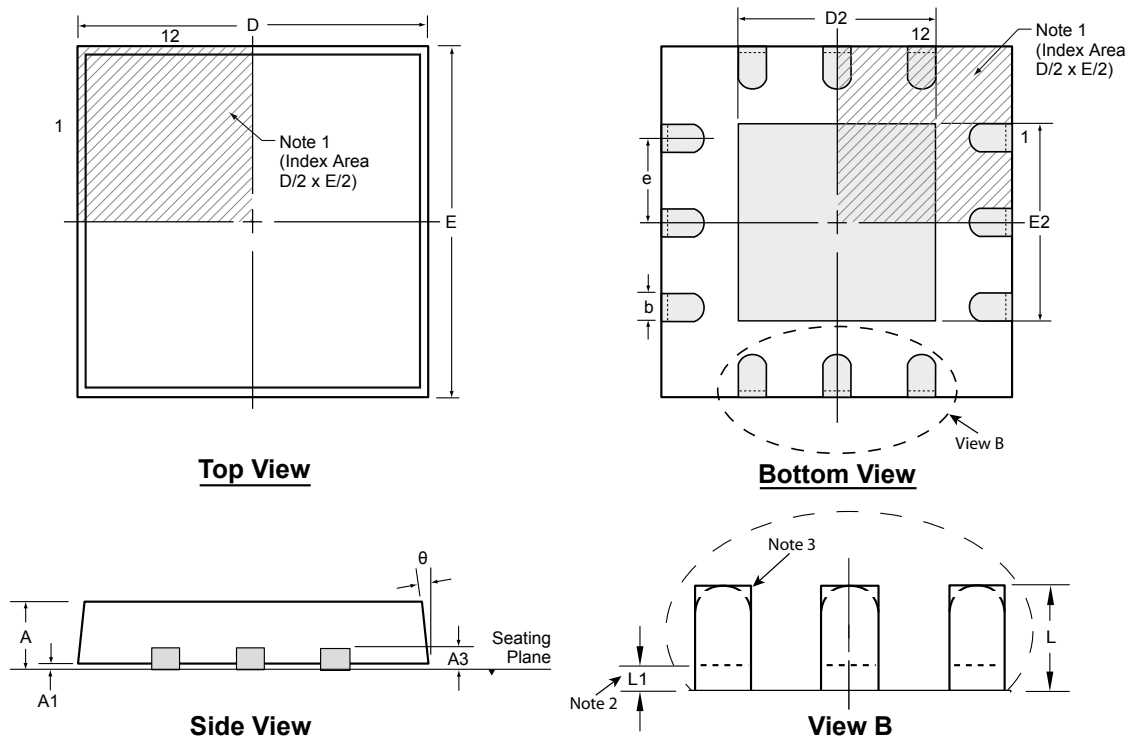

Note: For the most current package drawings, see the Microchip Packaging Specification at [www.microchip.com/packaging](http://www.microchip.com/packaging).

**Notes:**

1. A Pin 1 identifier must be located in the index area indicated. The Pin 1 identifier can be: a molded mark/identifier; an embedded metal marker; or a printed indicator.
2. Depending on the method of manufacturing, a maximum of 0.15mm pullback (L1) may be present.
3. The inner tip of the lead may be either rounded or square.

Symbol	A	A1	A3	b	D	D2	E	E2	e	L	L1	θ	
Dimension (mm)	MIN	0.70	0.00	0.20 REF	0.18	2.85*	1.25	2.85*	1.25	0.50 BSC	0.30	0.00	0°
	NOM	0.75	0.02		0.25	3.00	-	3.00	-		0.40	-	-
	MAX	0.80	0.05		0.30	3.15*	1.65	3.15*	1.65		0.50	0.15	14°

JEDEC Registration MO-220, Variation WEED-5, Issue K, June 2006.

\* This dimension is not specified in the JEDEC drawing.

Drawings not to scale.

---



---

## Package Outlines and Dimensions

---



---

### 16-Lead QFN Package Outline (K7)

**3.00x3.00mm body, 0.80mm height (max), 0.50mm pitch**

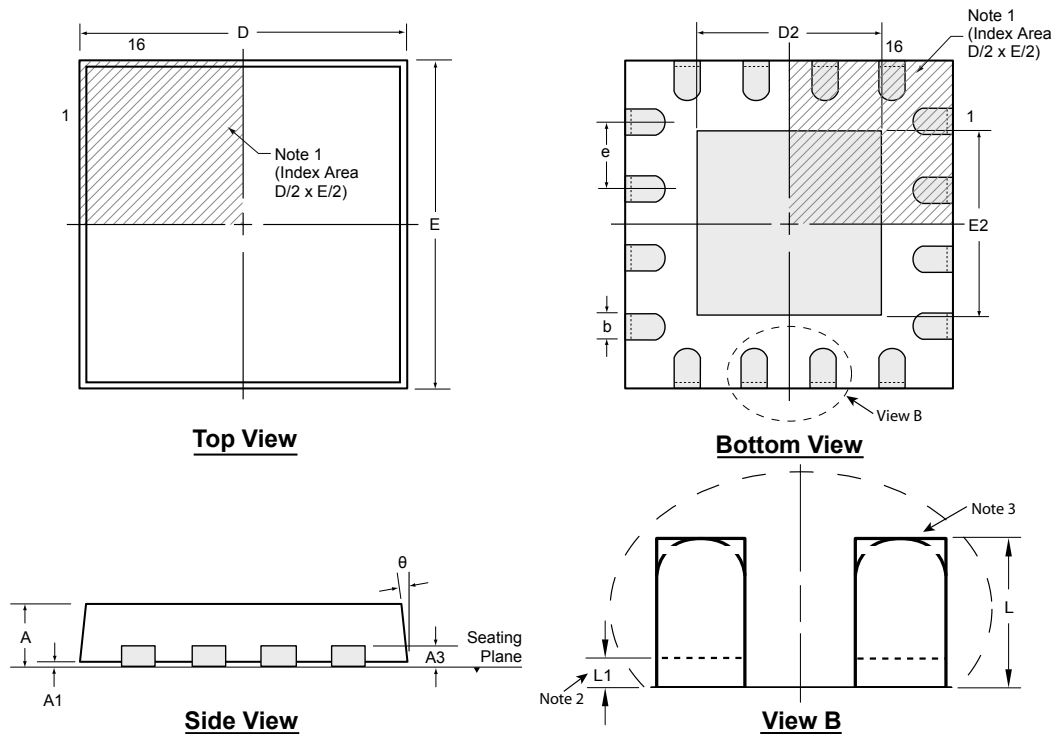

Note: For the most current package drawings, see the Microchip Packaging Specification at [www.microchip.com/packaging](http://www.microchip.com/packaging).

**Notes:**

1. A Pin 1 identifier must be located in the index area indicated. The Pin 1 identifier can be: a molded mark/identifier; an embedded metal marker; or a printed indicator.
2. Depending on the method of manufacturing, a maximum of 0.15mm pullback ( $L1$ ) may be present.
3. The inner tip of the lead may be either rounded or square.

Symbol	A	A1	A3	b	D	D2	E	E2	e	L	L1	$\theta$	
Dimension (mm)	MIN	0.70	0.00	0.20 REF	0.18	2.85*	1.50	2.85*	1.50	0.50 BSC	0.20 <sup>†</sup>	0.00	0°
	NOM	0.75	0.02		0.25	3.00	1.65	3.00	1.65		0.30 <sup>†</sup>	-	-
	MAX	0.80	0.05		0.30	3.15*	1.80	3.15*	1.80		0.45	0.15	14°

JEDEC Registration MO-220, Variation WEED-4, Issue K, June 2006.

\* This dimension is not specified in the JEDEC drawing.

† This dimension differs from the JEDEC drawing.

**Drawings not to scale.**

**Package Outlines and Dimensions**

**32-Lead QFN Package Outline (K7)**

*5.00x5.00mm body, 0.80mm height (max), 0.50mm pitch*

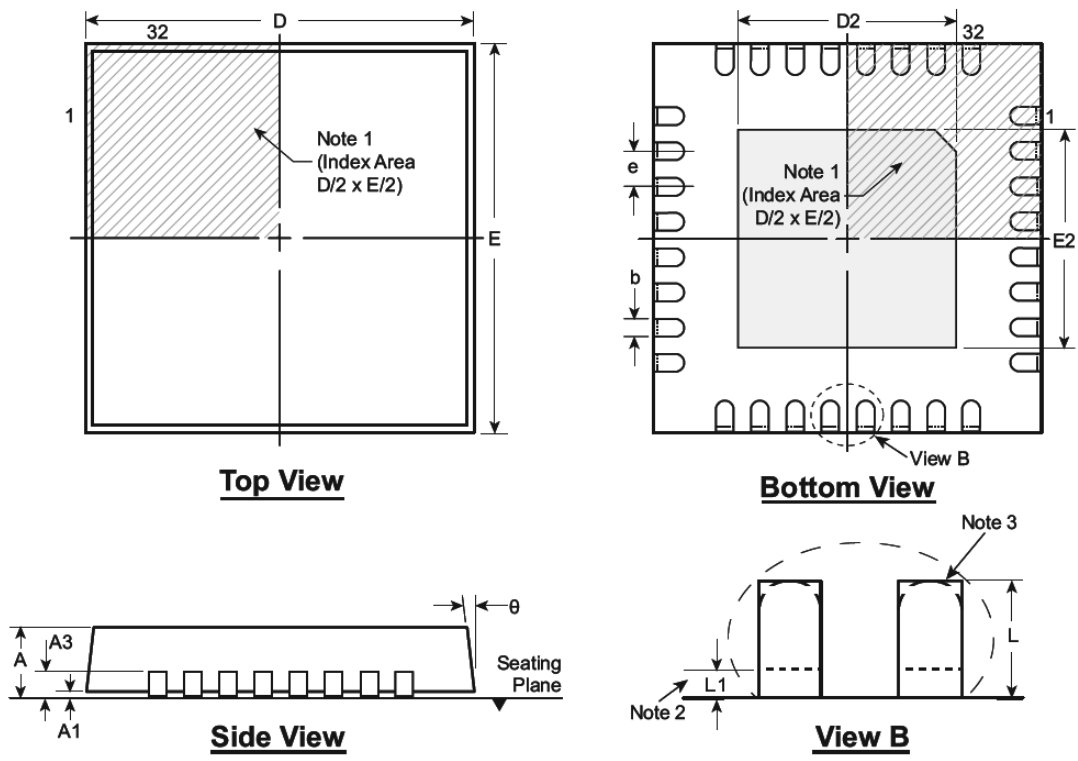

Note: For the most current package drawings, see the Microchip Packaging Specification at [www.microchip.com/packaging](http://www.microchip.com/packaging).

**Notes:**

1. A Pin 1 identifier must be located in the index area indicated. The Pin 1 identifier can be: a molded mark/identifier; an embedded metal marker; or a printed indicator.
2. Depending on the method of manufacturing, a maximum of 0.15mm pullback (L1) may be present.
3. The inner tip of the lead may be either rounded or square.

Symbol	A	A1	A3	b	D	D2	E	E2	e	L	L1	θ	
Dimension (mm)	MIN	0.70	0.00	0.20 REF	0.18	4.85*	1.05	4.85*	1.05	0.50 BSC	0.30 <sup>†</sup>	0.00	0°
	NOM	0.75	0.02		0.25	5.00	-	5.00	-		0.40 <sup>†</sup>	-	-
	MAX	0.80	0.05		0.30	5.15*	3.55 <sup>†</sup>	5.15*	3.55 <sup>†</sup>		0.50 <sup>†</sup>	0.15	14°

JEDEC Registration MO-220, Variation WHHD-6, Issue K, June 2006.

\* This dimension is not specified in the JEDEC drawing.

† This dimension differs from the JEDEC drawing.

**Drawings not to scale.**

---



---

## Package Outlines and Dimensions

---



---

### 32-Lead QFN Package Outline (K7)

**6.00x6.00mm body, 0.80mm height (max), 0.50mm pitch**

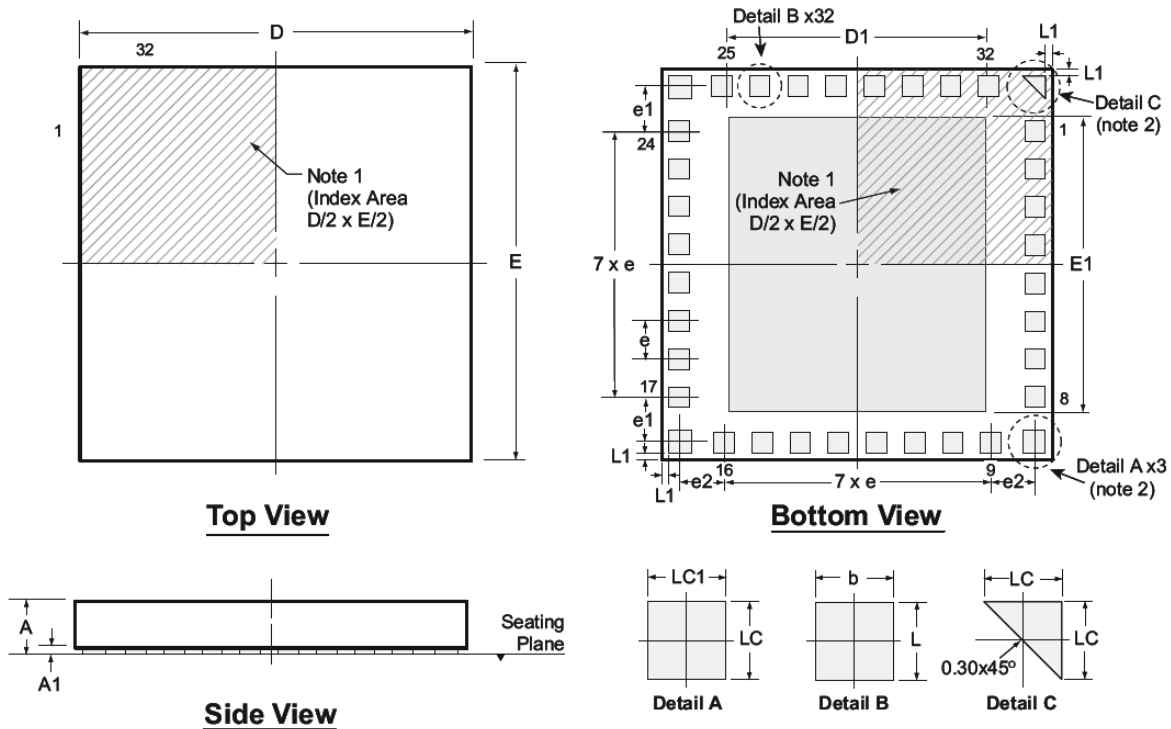

Note: For the most current package drawings, see the Microchip Packaging Specification at [www.microchip.com/packaging](http://www.microchip.com/packaging).

**Notes:**

1. A Pin 1 identifier must be located in the index area indicated. The Pin 1 identifier can be: a molded mark/identifier, an embedded metal marker, or a printed indicator.
2. The 4 corner pads are for mechanical placement only, they are not internally connected.

Symbol	A	A1	b	D	D1	E	E1	e	e1	e2	L	L1	LC	LC1	
Dimension (mm)	MIN	0.70	0.00	0.20	5.90	3.20	5.90	4.30	0.50 BSC	1.00 REF	0.975 REF	0.20 0.30 0.40	0.10 REF	0.20	0.25
	NOM	0.75	-	0.30	6.00	3.30	6.00	4.40						0.30	0.35
	MAX	0.80	0.05	0.40	6.10	3.40	6.10	4.50						0.40	0.45

Drawings not to scale.

**Package Outlines and Dimensions**

**40-Lead QFN Package Outline (K7)**  
**5.00x5.00mm body, 0.80mm height (max), 0.40mm pitch**

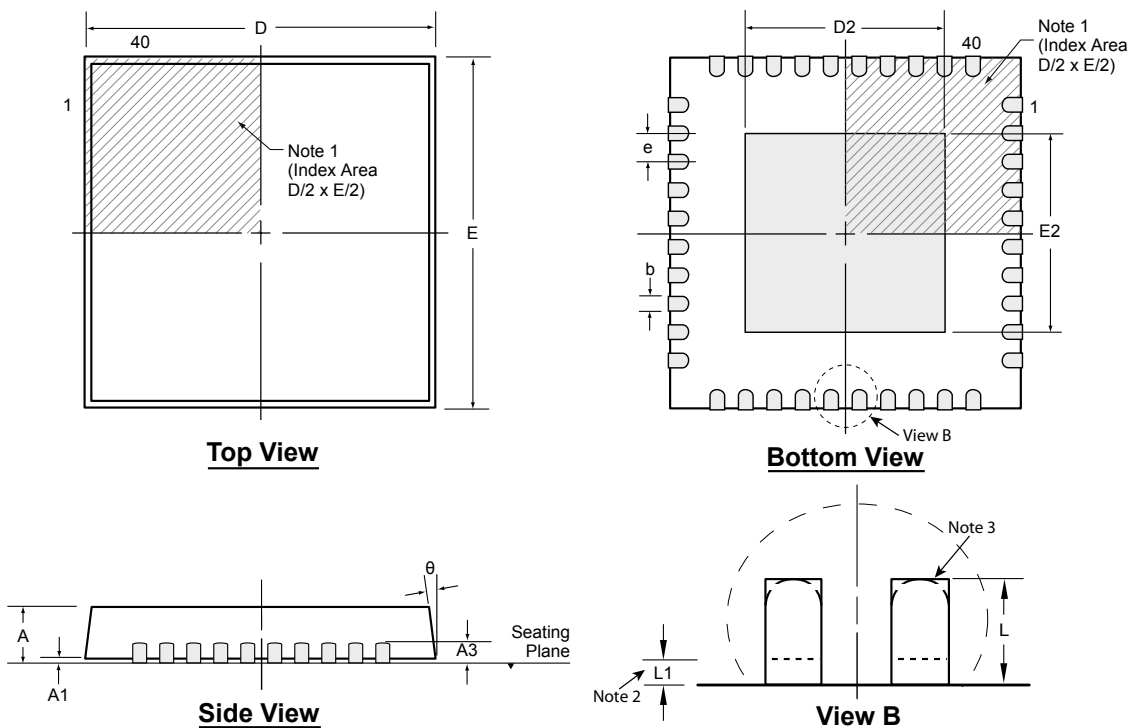

Note: For the most current package drawings, see the Microchip Packaging Specification at [www.microchip.com/packaging](http://www.microchip.com/packaging).

**Notes:**

1. A Pin 1 identifier must be located in the index area indicated. The Pin 1 identifier can be: a molded mark/identifier; an embedded metal marker; or a printed indicator.
2. Depending on the method of manufacturing, a maximum of 0.15mm pullback ( $L1$ ) may be present.
3. The inner tip of the lead may be either rounded or square.

Symbol	A	A1	A3	b	D	D2	E	E2	e	L	L1	$\theta$	
Dimension (mm)	MIN	0.70	0.00	0.20 REF	0.15	4.85*	3.45	4.85*	3.45	0.40 BSC	0.25†	0.00	0°
	NOM	0.75	0.02		0.20	5.00	3.60	5.00	3.60		0.35†	-	-
	MAX	0.80	0.05		0.25	5.15*	3.70†	5.15*	3.70†		0.45†	0.15	14°

JEDEC Registration MO-220, Variation WHHE-1, Issue K, June 2006

\* This dimension is not specified in the JEDEC drawing.

† This dimension differs from the JEDEC drawing.

Drawings not to scale.

---



---

## Package Outlines and Dimensions

---



---

### 44-Lead QFN Package Outline (K7)

7.00x7.00mm body, 0.80mm height (max), 0.50mm pitch

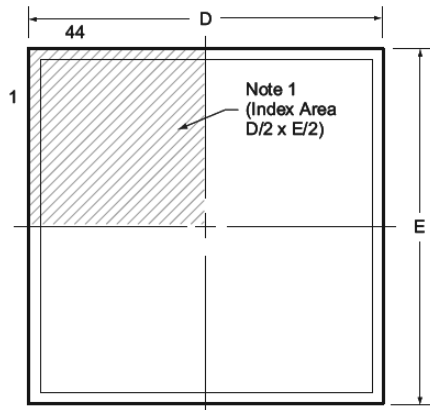

**Top View**

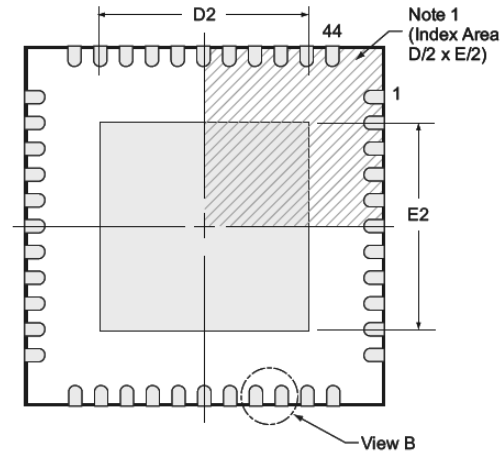

**Bottom View**

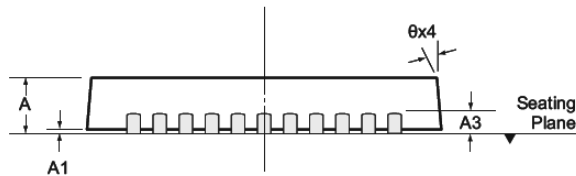

**Side View**

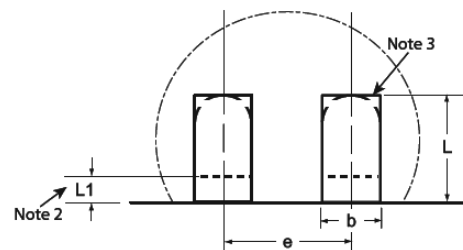

**View B**

Note: For the most current package drawings, see the Microchip Packaging Specification at [www.microchip.com/packaging](http://www.microchip.com/packaging).

**Notes:**

1. A Pin 1 identifier must be located in the index area indicated. The Pin 1 identifier can be: a molded mark/identifier, an embedded metal marker, or a printed indicator.
2. Depending on the method of manufacturing, a maximum of 0.15mm pullback (L1) may be present.
3. The inner tip of the lead may be either rounded or square.

Symbol	A	A1	A3	b	D	D2	E	E2	e	L	L1	θ	
Dimension (mm)	MIN	0.70	0.00	0.20 REF	0.18	6.85*	5.00†	6.85*	5.00†	0.50 BSC	0.45†	0.00	0°
	NOM	0.75	0.02		0.25	7.00	5.15†	7.00	5.15†		0.55†	-	-
	MAX	0.80	0.05		0.30	7.15*	5.25†	7.15*	5.25†		0.65†	0.15	14°

JEDEC Registration MO-220, Variation WKKD-3, Issue K, June 2006

\* This dimension is not specified in the JEDEC drawing.

† This dimension differs from the JEDEC drawing.

**Drawings not to scale.**



**MICROCHIP**

---

---

**Package Outlines and Dimensions**

---

---

**NOTES:**



---

---

**Package Outlines and Dimensions**

---

---

**QSOP**

Supertex Legacy

**Package Outlines and Dimensions**

**44-Lead QSOP Package Outline (QP)**

*17.83x7.50mm body, 2.64mm height (max), 0.80mm pitch*

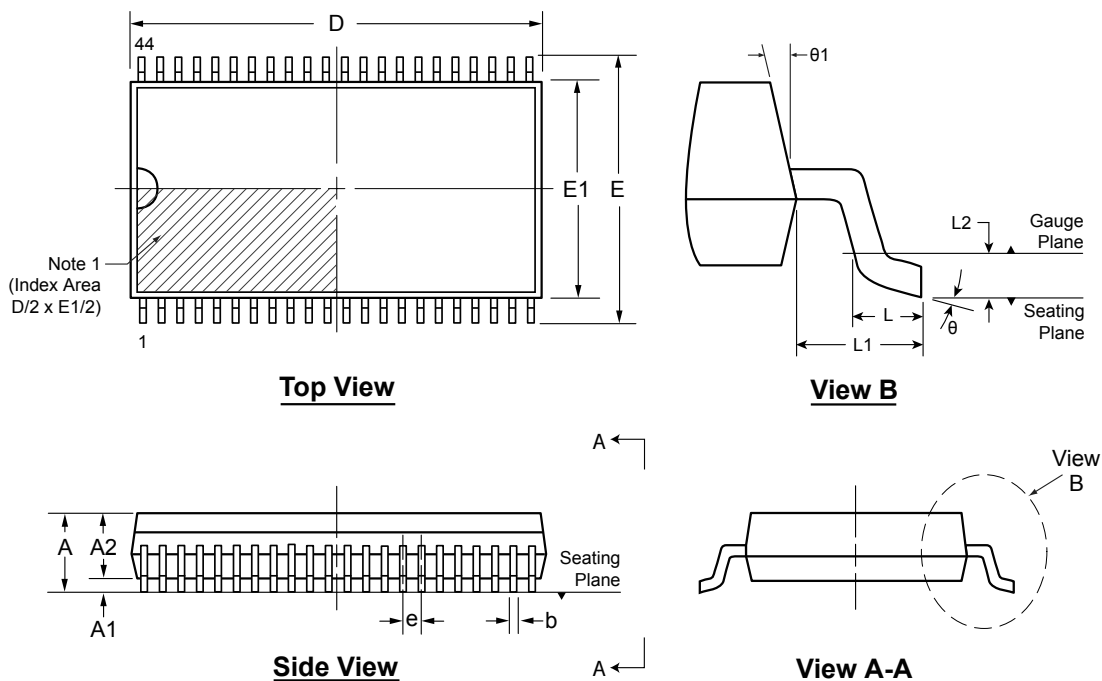

Note: For the most current package drawings, see the Microchip Packaging Specification at [www.microchip.com/packaging](http://www.microchip.com/packaging).

**Note:**

1. A Pin 1 identifier must be located in the index area indicated. The Pin 1 identifier can be: a molded mark/identifier; an embedded metal marker; or a printed indicator.

Symbol	A	A1	A2	b	D	E	E1	e	L	L1	L2	$\theta$	$\theta 1$
Dimensions (mm)	MIN	2.44	0.10	2.34	0.28	17.73	10.11	7.40	0.80 REF	0.40	1.405 REF	0.355 BSC	0°
	NOM	-	-	-	-	-	-	-		-			7°
	MAX	2.64	0.30	2.54	0.51	17.93	10.51	7.60		1.27			8°

Drawings are not to scale.

---

---

**Package Outlines and Dimensions**

---

---

**SOIC**

Supertex Legacy

**Package Outlines and Dimensions**

**8-Lead SOIC (Narrow Body w/Heat Slug) Package Outline (SG)**  
**4.90x3.90mm body, 1.70mm height (max), 1.27mm pitch**

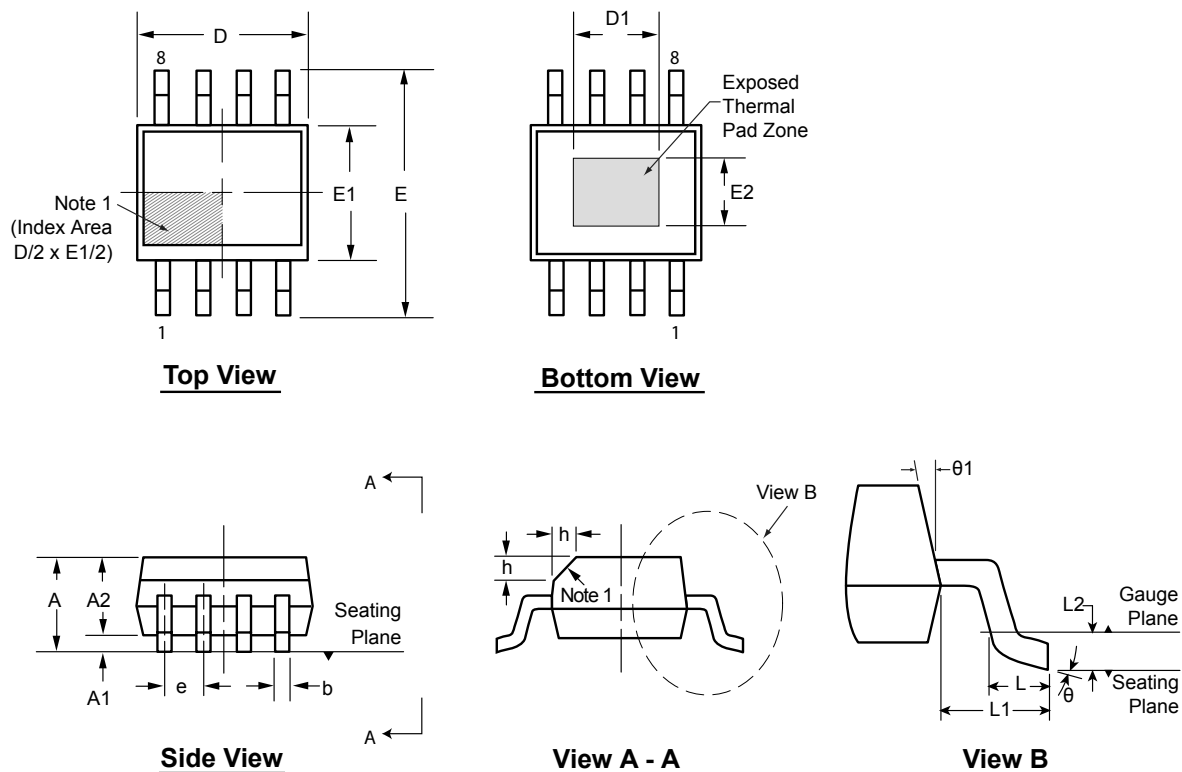

Note: For the most current package drawings, see the Microchip Packaging Specification at [www.microchip.com/packaging](http://www.microchip.com/packaging).

**Note:**

1. If optional chamfer feature is not present, a Pin 1 identifier must be located in the index area indicated. The Pin 1 identifier can be: a molded mark/identifier; an embedded metal marker; or a printed indicator.

Symbol	A	A1	A2	b	D	D1	E	E1	E2	e	h	L	L1	L2	θ	θ1				
Dimension (mm)	MIN	1.25*	0.00	1.25	0.31	4.80*	3.30 <sup>†</sup>	5.80*	3.80*	2.29 <sup>†</sup>	1.27 BSC	0.25	0.40	1.04 REF	0.25 BSC	0°	5°			
	NOM	-	-	-	-	4.90	-	6.00	3.90	-		-	-			-	-	-	-	-
	MAX	1.70	0.15	1.55*	0.51	5.00*	3.81 <sup>†</sup>	6.20*	4.00*	2.79 <sup>†</sup>		0.50	1.27			8°	15°			

JEDEC Registration MS-012, Variation BA, Issue E, Sept. 2005.

\* This dimension is not specified in the JEDEC drawing.

† This dimension differs from the JEDEC drawing.

Drawings not to scale.

---



---

## Package Outlines and Dimensions

---



---

### 8-Lead SOIC (Narrow Body) Package Outline (LG/TG) 4.90x3.90mm body, 1.75mm height (max), 1.27mm pitch

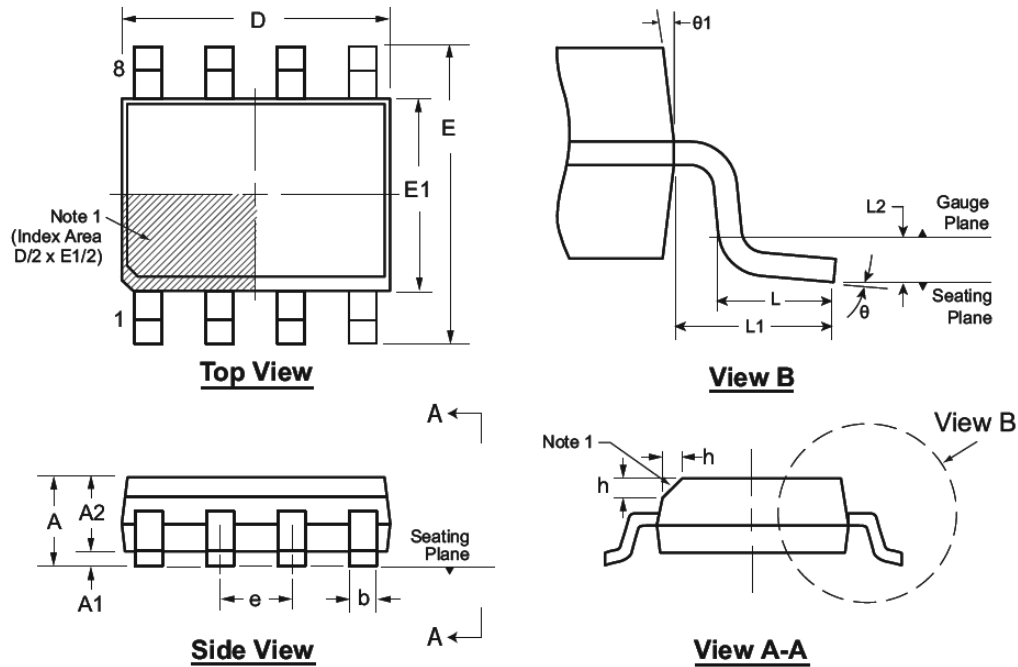

Note: For the most current package drawings, see the Microchip Packaging Specification at [www.microchip.com/packageing](http://www.microchip.com/packageing).

**Note:**

1. This chamfer feature is optional. A Pin 1 identifier must be located in the index area indicated. The Pin 1 identifier can be: a molded mark/identifier; an embedded metal marker; or a printed indicator.

Symbol	A	A1	A2	b	D	E	E1	e	h	L	L1	L2	$\theta$	$\theta1$		
Dimension (mm)	MIN	1.35*	0.10	1.25	0.31	4.80*	5.80*	3.80*	1.27 BSC	0.25	0.40	1.04 REF	0.25 BSC	0°	5°	
	NOM	-	-	-	-	4.90	6.00	3.90		-	-		-	-	-	-
	MAX	1.75	0.25	1.65*	0.51	5.00*	6.20*	4.00*		0.50	1.27		8°	15°		

JEDEC Registration MS-012, Variation AA, Issue E, Sept. 2005.

\* This dimension is not specified in the JEDEC drawing.

Drawings are not to scale.

**Package Outlines and Dimensions**

**14-Lead SOIC (Narrow Body) Package Outline (NG)**  
**8.65x3.90mm body, 1.75mm height (max), 1.27mm pitch**

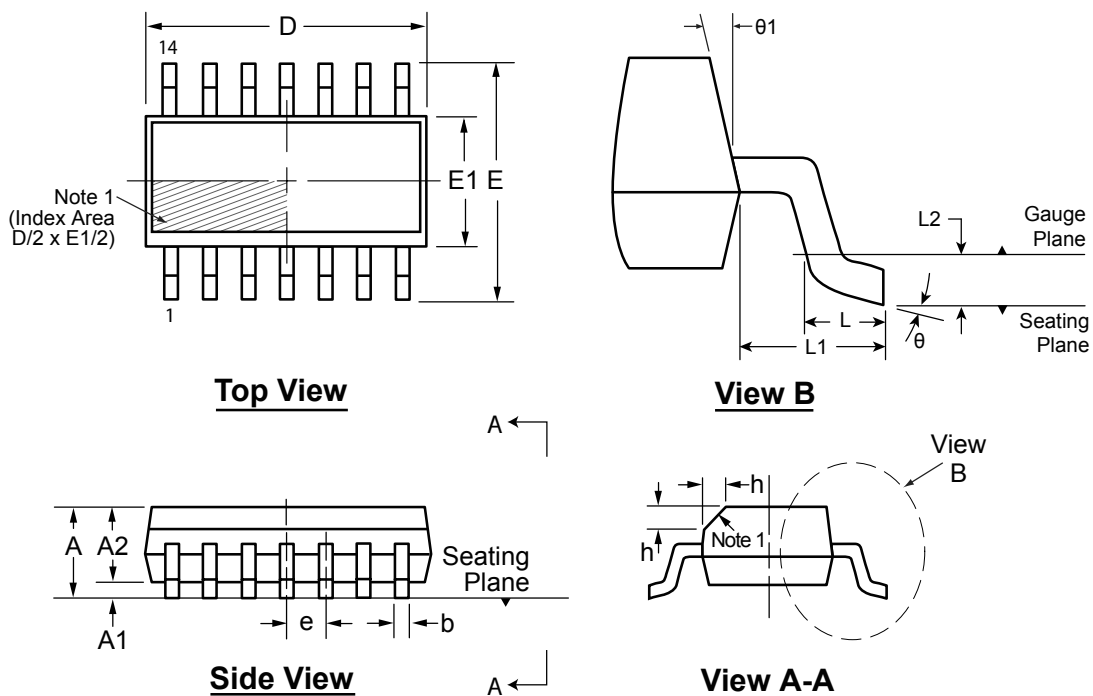

Note: For the most current package drawings, see the Microchip Packaging Specification at [www.microchip.com/packaging](http://www.microchip.com/packaging).

**Note:**

1. This chamfer feature is optional. If it is not present, then a Pin 1 identifier must be located in the index area indicated. The Pin 1 identifier can be: a molded mark/identifier; an embedded metal marker; or a printed indicator.

Symbol	A	A1	A2	b	D	E	E1	e	h	L	L1	L2	θ	θ1		
Dimension (mm)	MIN	1.35*	0.10	1.25	0.31	8.55*	5.80*	3.80*	1.27 BSC	0.25	0.40	1.04 REF	0.25	0°	5°	
	NOM	-	-	-	-	8.65	6.00	3.90		-	-		-	-	-	-
	MAX	1.75	0.25	1.65*	0.51	8.75*	6.20*	4.00*		0.50	1.27		-	0.25 BSC	8°	15°

JEDEC Registration MS-012, Variation AB, Issue E, Sept. 2005.

\* This dimension is not specified in the JEDEC drawing.

Drawings are not to scale.

---



---

## Package Outlines and Dimensions

---



---

### 16-Lead SOIC (Narrow Body) Package Outline (NG) 9.90x3.90mm body, 1.75mm height (max), 1.27mm pitch

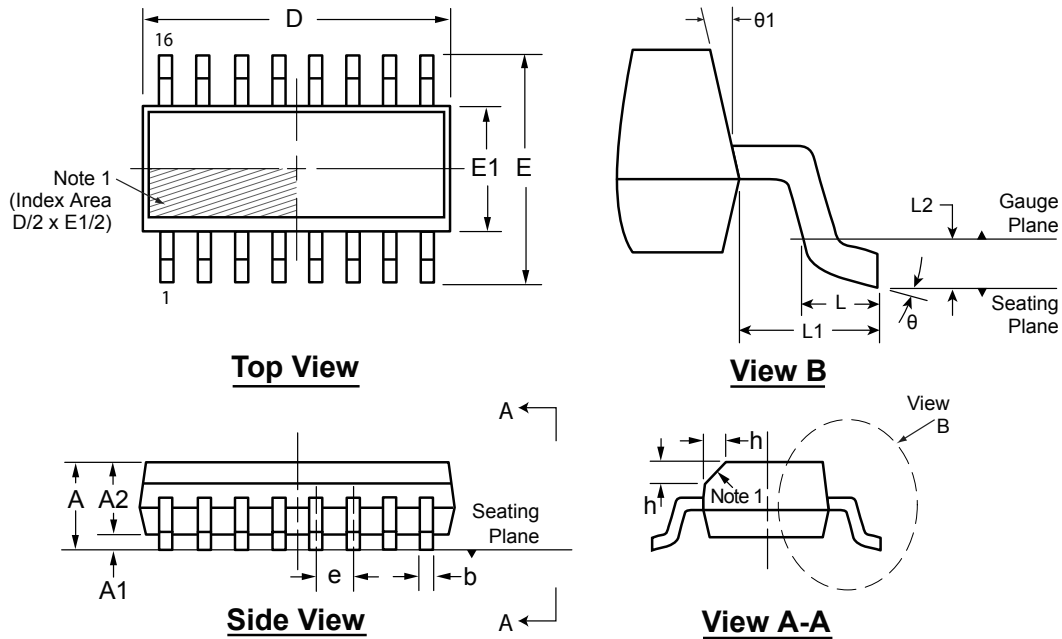

Note: For the most current package drawings, see the Microchip Packaging Specification at [www.microchip.com/packaging](http://www.microchip.com/packaging).

**Note:**

1. This chamfer feature is optional. If it is not present, then a Pin 1 identifier must be located in the index area indicated. The Pin 1 identifier can be: a molded mark/identifier; an embedded metal marker; or a printed indicator.

Symbol	A	A1	A2	b	D	E	E1	e	h	L	L1	L2	$\theta$	$\theta 1$	
Dimension (mm)	MIN	1.35*	0.10	1.25	0.31	9.80*	5.80*	3.80*	1.27 BSC	0.25	0.40	1.04 REF	0.25 BSC	0°	5°
	NOM	-	-	-	-	9.90	6.00	3.90		-	-			-	-
	MAX	1.75	0.25	1.65*	0.51	10.00*	6.20*	4.00*		0.50	1.27			8°	15°

JEDEC Registration MS-012, Variation AC, Issue E, Sept. 2005.

\* This dimension is not specified in the JEDEC drawing.

Drawings are not to scale.

**Package Outlines and Dimensions**

**16-Lead SOIC (Narrow Body) Package Outline (NG)**

**Pins #2 and #3 Trimmed**

*9.90x3.90mm body, 1.75mm height (max), 1.27mm pitch*

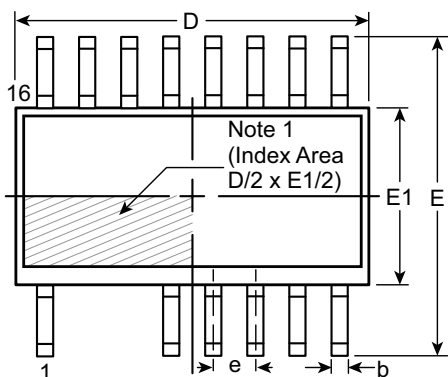

**Top View**

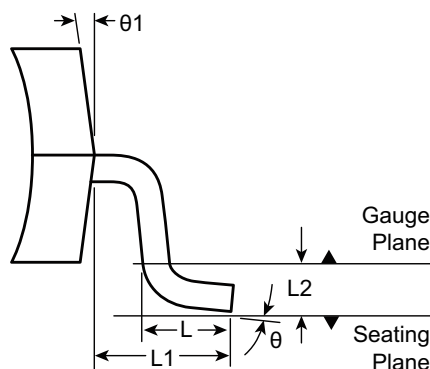

**View B**

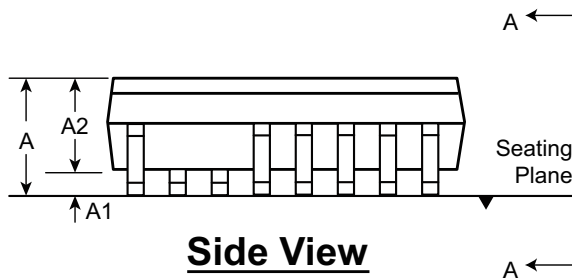

**Side View**

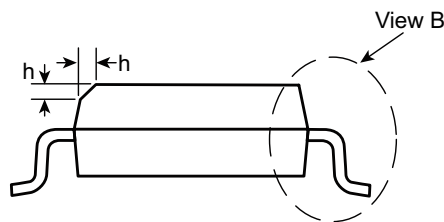

**View A-A**

Note: For the most current package drawings, see the Microchip Packaging Specification at [www.microchip.com/packaging](http://www.microchip.com/packaging).

**Note:**

- This chamfer feature is optional. If it is not present, then a Pin 1 identifier must be located in the index area indicated. The Pin 1 identifier can be: a molded mark/identifier; an embedded metal marker; or a printed indicator.

Symbol	A	A1	A2	b	D	E	E1	e	h	L	L1	L2	θ	θ1		
Dimension (mm)	MIN	1.35*	0.10	1.25	0.31	9.80*	5.80*	3.80*	1.27 BSC	0.25	0.40	1.04 REF	0.25	BSC	0°	5°
	NOM	-	-	-	-	9.90	6.00	3.90		-	-		-		-	
	MAX	1.75	0.25	1.65*	0.51	10.00*	6.20*	4.00*		0.50	1.27		8°		15°	

JEDEC Registration MS-012, Variation AC, Issue E, Sept. 2005.

\* This dimension is not specified in the JEDEC drawing.

Drawings are not to scale.



---

---

**Package Outlines and Dimensions**

---

---

**SOT-23**

Supertex Legacy

**Package Outlines and Dimensions**

**3-Lead TO-236AB (SOT-23) Package Outline (K1/T)**  
 2.90x1.30mm body, 1.12mm height (max), 1.90mm pitch

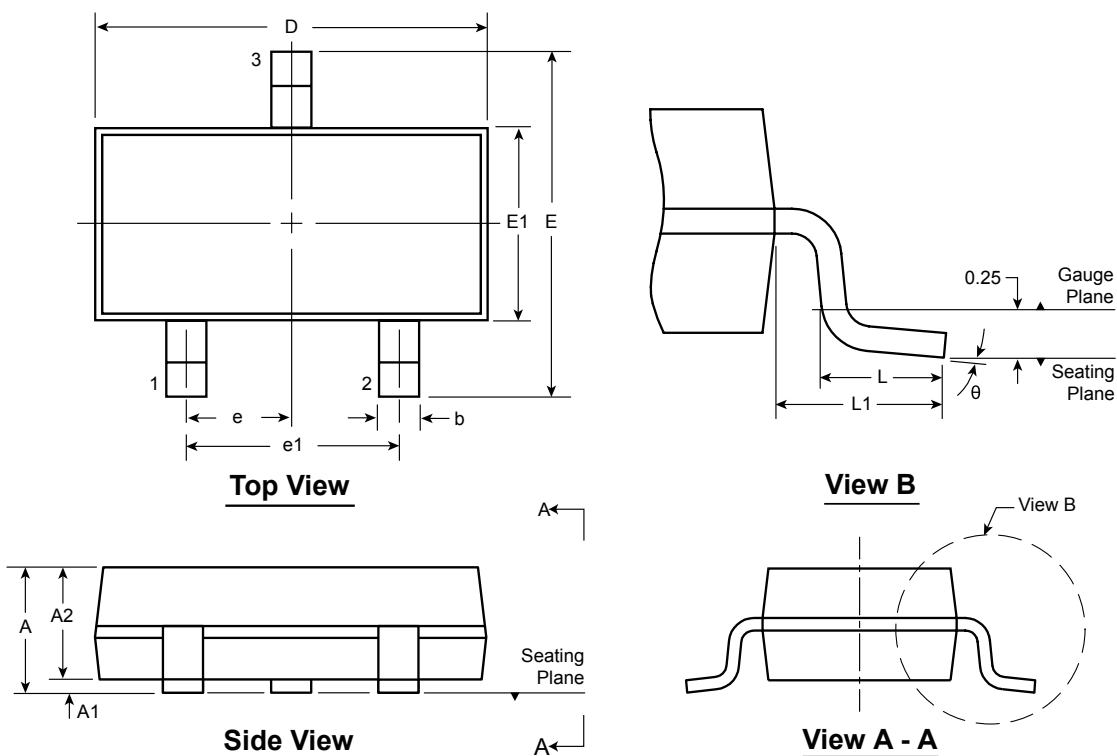

Note: For the most current package drawings, see the Microchip Packaging Specification at [www.microchip.com/packaging](http://www.microchip.com/packaging).

Symbol		A	A1	A2	b	D	E	E1	e	e1	L	L1	$\theta$
Dimension (mm)	MIN	0.89	0.01	0.88	0.30	2.80	2.10	1.20	0.95 BSC	1.90 BSC	0.20†	0.54 REF	0°
	NOM	-	-	0.95	-	2.90	-	1.30			0.50		-
	MAX	1.12	0.10	1.02	0.50	3.04	2.64	1.40			0.60		8°

JEDEC Registration TO-236, Variation AB, Issue H, Jan. 1999.

† This dimension differs from the JEDEC drawing.

Drawings not to scale.

---



---

## Package Outlines and Dimensions

---



---

### 5-Lead SOT-23 Package Outline (K1)

2.90x1.60mm body, 1.45mm height (max), 0.95mm pitch

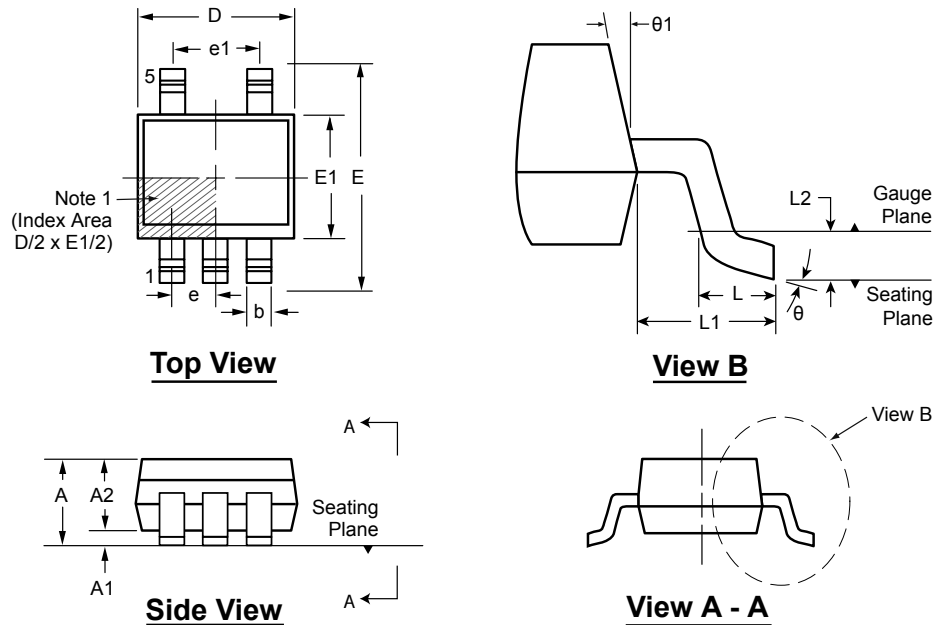

Note: For the most current package drawings, see the Microchip Packaging Specification at [www.microchip.com/packaging](http://www.microchip.com/packaging).

**Note:**

1. A Pin 1 identifier must be located in the index area indicated. The Pin 1 identifier can be: a molded mark/identifier; an embedded metal marker; or a printed indicator.

Symbol	A	A1	A2	b	D	E	E1	e	e1	L	L1	L2	$\theta$	$\theta 1$	
Dimension (mm)	MIN	0.90*	0.00	0.90	0.30	2.75*	2.60*	1.45*	0.95 BSC	1.90 BSC	0.30	0.60 REF	0.25 BSC	0°	5°
	NOM	-	-	1.15	-	2.90	2.80	1.60			0.45			4°	10°
	MAX	1.45	0.15	1.30	0.50	3.05*	3.00*	1.75*			0.60			8°	15°

JEDEC Registration MO-178, Variation AA, Issue C, Feb. 2000.

\* This dimension is not specified in the JEDEC drawing.

Drawings not to scale.



**MICROCHIP**

---

---

**Package Outlines and Dimensions**

---

---

**NOTES:**

---

---

**Package Outlines and Dimensions**

---

---

**SOT-223**

Supertex Legacy

**Package Outlines and Dimensions**

**3-Lead SOT-223 Package Outline (K5)**

*6.50x3.50mm body, 1.80mm height (max), 2.30mm pitch*

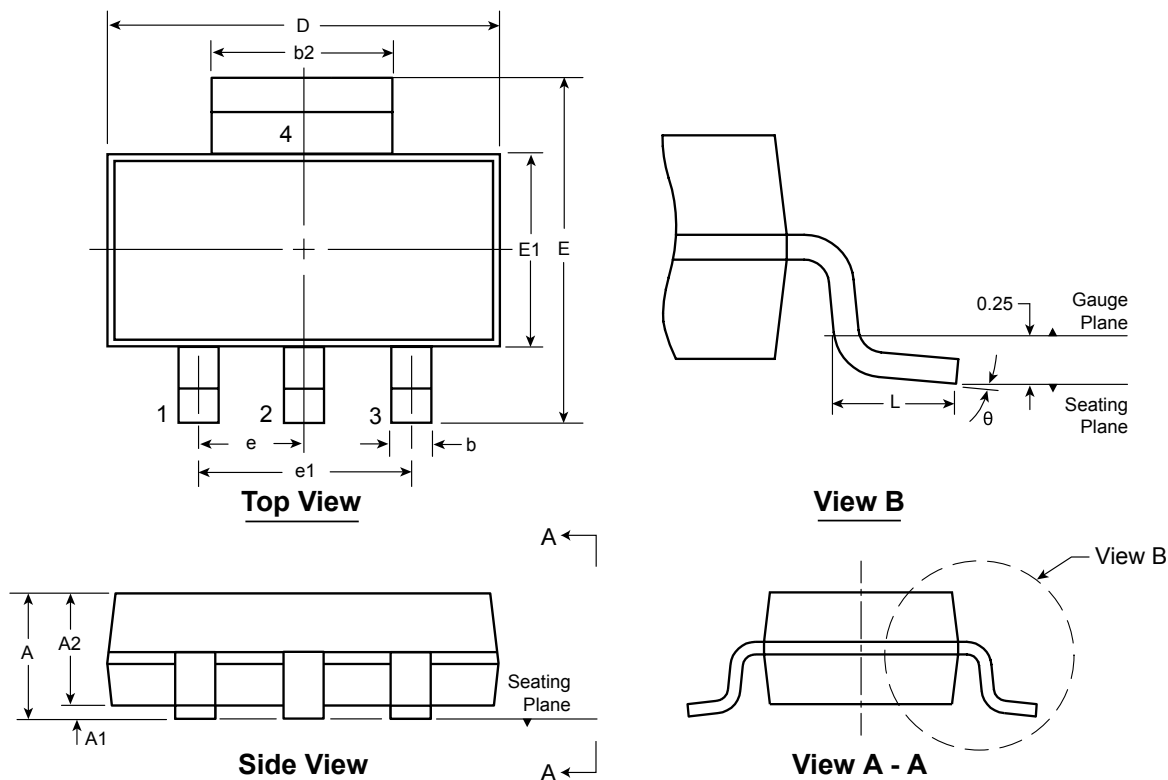

Note: For the most current package drawings, see the Microchip Packaging Specification at [www.microchip.com/packaging](http://www.microchip.com/packaging).

Symbol	A	A1	A2	b	b2	D	E	E1	e	e1	L	$\theta$	
Dimension (mm)	MIN	1.48*	0.02	1.50	0.65 <sup>†</sup>	2.90	6.30	6.70	3.30	2.30 BSC	4.60 BSC	0.75	0°
	NOM	-	-	1.60	0.76	3.00	6.50	7.00	3.50			-	-
	MAX	1.80	0.10	1.70	0.85 <sup>†</sup>	3.15 <sup>†</sup>	6.70	7.30	3.70			-	10°

JEDEC Registration TO-261, Variation AA, Issue C, May 2002.

\* This dimension is not specified in the JEDEC drawing.

† This dimension differs from the JEDEC drawing.

Drawings not to scale.

---

---

**Package Outlines and Dimensions**

---

---

**SOW**

Supertex Legacy

**Package Outlines and Dimensions**

**16-Lead SOW (Wide Body w/Heat Slug) Package Outline (SG)**  
**10.30x7.50mm body, 2.64mm height (max), 1.27mm pitch**

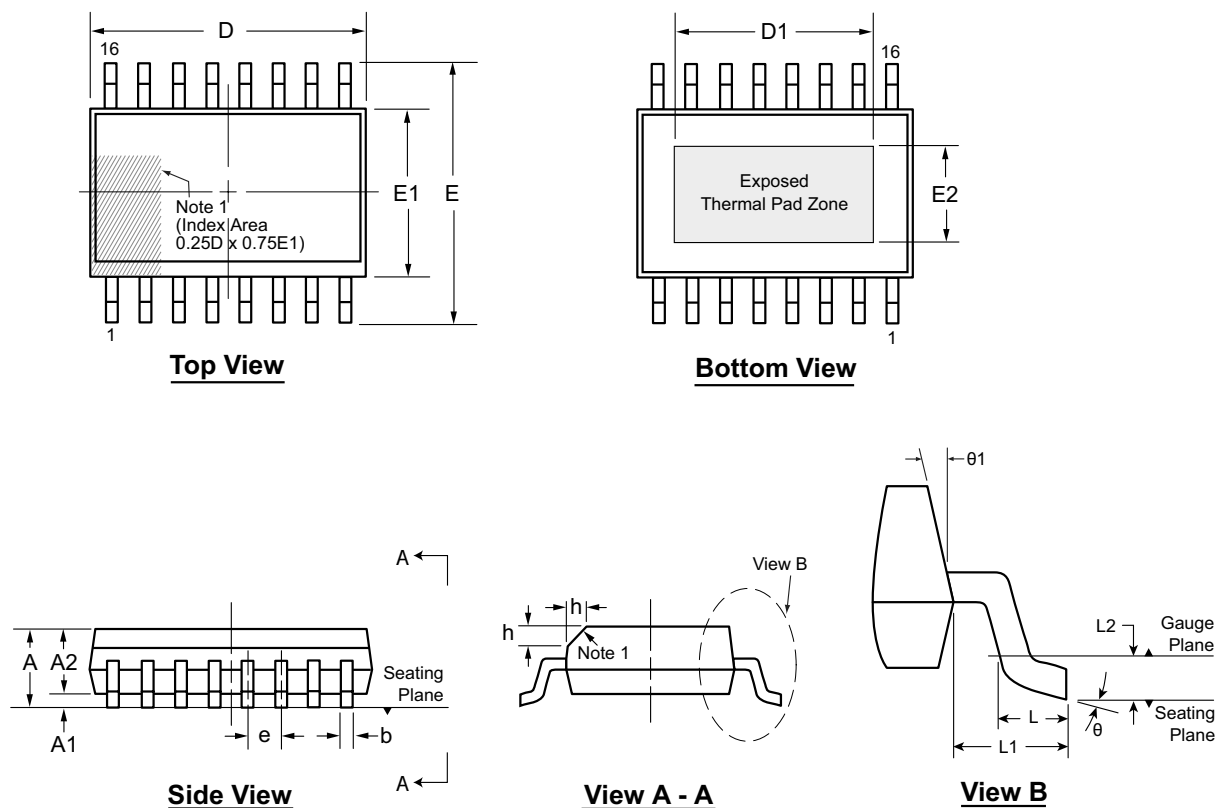

Note: For the most current package drawings, see the Microchip Packaging Specification at [www.microchip.com/packaging](http://www.microchip.com/packaging).

**Notes:**

1. If optional chamfer feature is not present, a Pin 1 identifier must be located in the index area indicated. The Pin 1 identifier can be: a molded mark/identifier; an embedded metal marker; or a printed indicator.

Symbol	A	A1	A2	b	D	D1	E	E1	E2	e	h	L	L1	L2	θ	θ1			
Dimension (mm)	MIN	2.06*	0.00	2.03†	0.31	10.10*	5.84†	9.97*	7.40*	4.57†	1.27 BSC	0.25	0.40	1.40 REF	0.25 BSC	0°	5°		
	NOM	-	-	-	-	10.30	-	10.30	7.50	-		-	-		-	-	-	-	-
	MAX	2.64†	0.15	2.54*	0.51	10.50*	6.35†	10.63*	7.60*	5.08†		0.75	1.27		-	-	8°	15°	

JEDEC Registration MS-013, Variation BA, Issue E, 2005.

\* This dimension is not specified in the JEDEC drawing.

† This dimension differs from the JEDEC drawing.

Drawings not to scale.



---



---

## Package Outlines and Dimensions

---



---

### 16-Lead SOW (Wide Body) Package Outline (WG)

10.30x7.50mm body, 2.65mm height (max), 1.27mm pitch

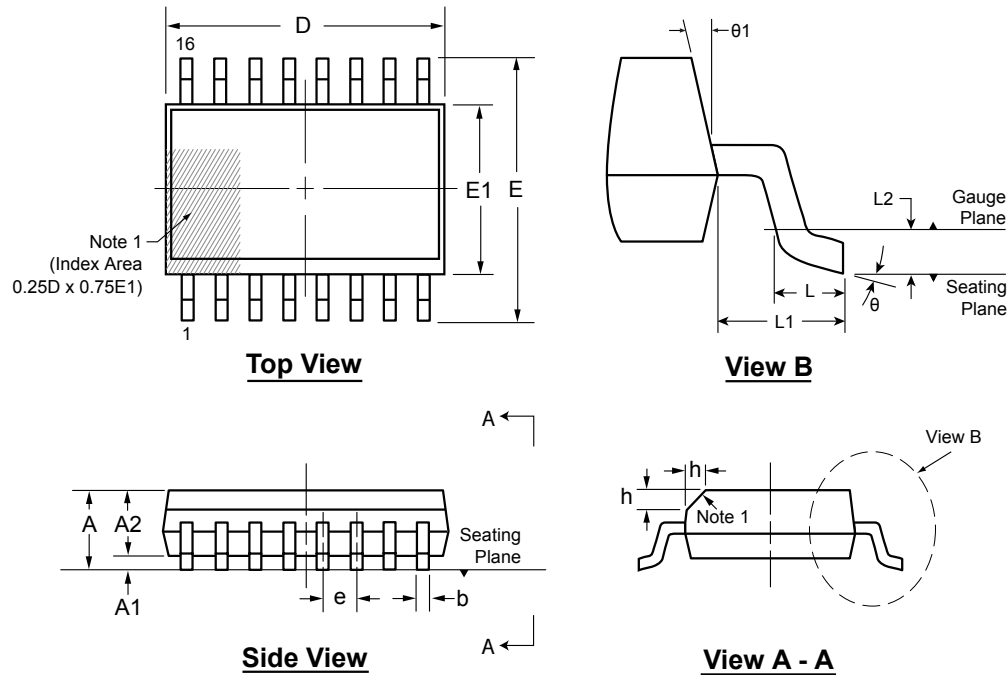

Note: For the most current package drawings, see the Microchip Packaging Specification at [www.microchip.com/packaging](http://www.microchip.com/packaging).

**Note:**

1. A Pin 1 identifier must be located in the index area indicated. The Pin 1 identifier can be: a molded mark/identifier; an embedded metal marker; or a printed indicator.

Symbol	A	A1	A2	b	D	E	E1	e	h	L	L1	L2	$\theta$	$\theta 1$		
Dimension (mm)	MIN	2.15*	0.10	2.05	0.31	10.10*	9.97*	7.40*	1.27 BSC	0.25	0.40	1.40 REF	0.25 BSC	0°	5°	
	NOM	-	-	-	-	10.30	10.30	7.50		-	-		-	-	-	-
	MAX	2.65	0.30	2.55*	0.51	10.50*	10.63*	7.60*		0.75	1.27		-	-	8°	15°

JEDEC Registration MS-013, Variation AA, Issue E, Sep. 2005.

\* This dimension is not specified in the JEDEC drawing.

Drawings are not to scale.

**Package Outlines and Dimensions**

**20-Lead SOW (Wide Body) Package Outline (WG)**  
**12.80x7.50mm body, 2.65mm height (max), 1.27mm pitch**

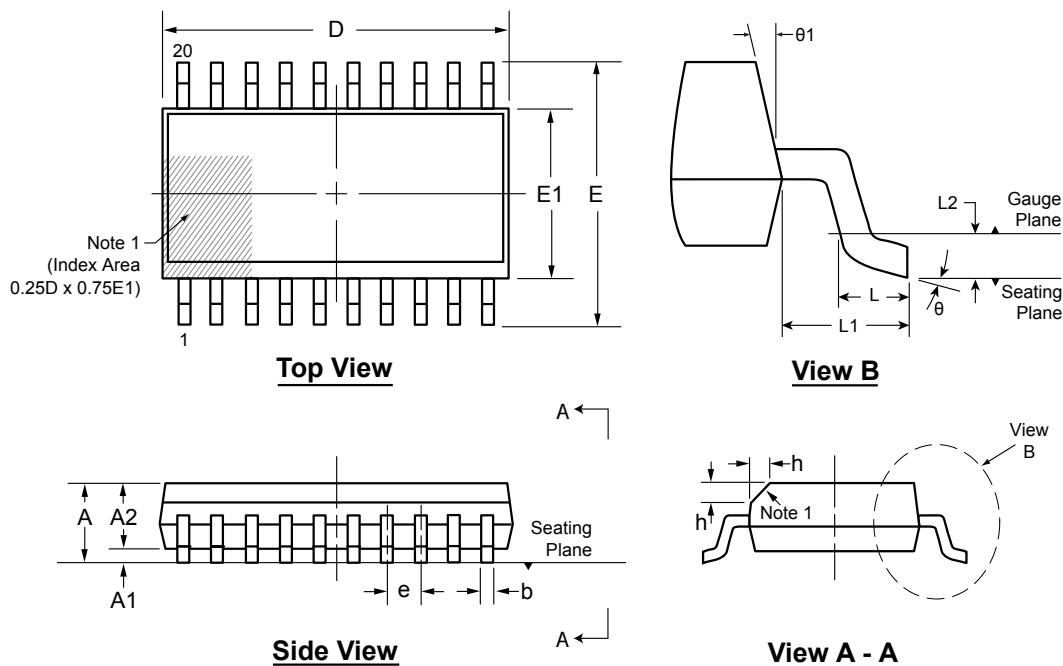

Note: For the most current package drawings, see the Microchip Packaging Specification at [www.microchip.com/packaging](http://www.microchip.com/packaging).

**Note:**

1. A Pin 1 identifier must be located in the index area indicated. The Pin 1 identifier can be: a molded mark/identifier; an embedded metal marker; or a printed indicator.

Symbol	A	A1	A2	b	D	E	E1	e	h	L	L1	L2	θ	θ1		
Dimension (mm)	MIN	2.15*	0.10	2.05	0.31	12.60*	9.97*	7.40*	1.27 BSC	0.25	0.40	1.40 REF	0.25	0°	5°	
	NOM	-	-	-	-	12.80	10.30	7.50		-	-		1.40	0.25	-	-
	MAX	2.65	0.30	2.55*	0.51	13.00*	10.63*	7.60*		0.75	1.27		1.40	0.25	8°	15°

JEDEC Registration MS-013, Variation AC, Issue E, Sep. 2005.

\* This dimension is not specified in the JEDEC drawing.

Drawings are not to scale.

---



---

## Package Outlines and Dimensions

---



---

### 24-Lead SOW (Wide Body) Package Outline (WG)

15.40x7.50 body, 2.65mm height (max), 1.27mm pitch

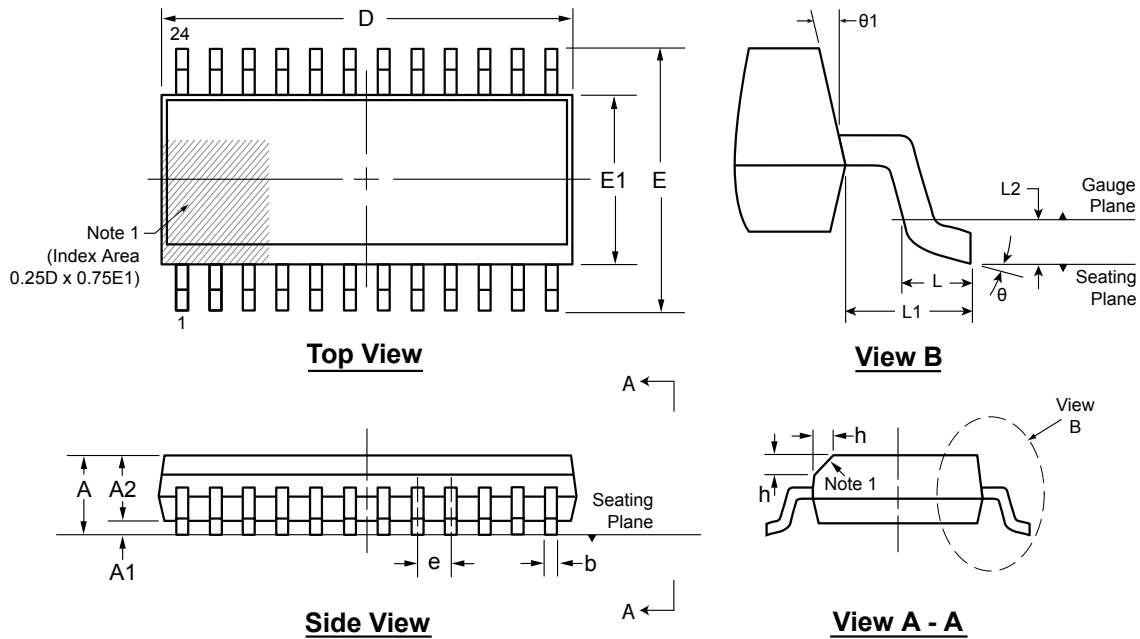

Note: For the most current package drawings, see the Microchip Packaging Specification at [www.microchip.com/packaging](http://www.microchip.com/packaging).

**Note:**

1. A Pin 1 identifier must be located in the index area indicated. The Pin 1 identifier can be: a molded mark/identifier; an embedded metal marker; or a printed indicator.

Symbol	A	A1	A2	b	D	E	E1	e	h	L	L1	L2	$\theta$	$\theta 1$		
Dimension (mm)	MIN	2.15*	0.10	2.05	0.31	15.20*	9.97*	7.40*	1.27 BSC	0.25	0.40	1.40 REF	0.25	0°	5°	
	NOM	-	-	-	-	15.40	10.30	7.50		-	-		-	-	-	-
	MAX	2.65	0.30	2.55*	0.51	15.60*	10.63*	7.60*		0.75	1.27		-	0.25	8°	15°

JEDEC Registration MS-013, Variation AD, Issue E, Sep. 2005.

\* This dimension is not specified in the JEDEC drawing.

Drawings are not to scale.

© 2017 Microchip Technology Inc. DS00000049CH

**Package Outlines and Dimensions**

**28-Lead SOW (Wide Body) Package Outline (WG)**  
**17.90x7.50mm body, 2.65mm height (max), 1.27mm pitch**

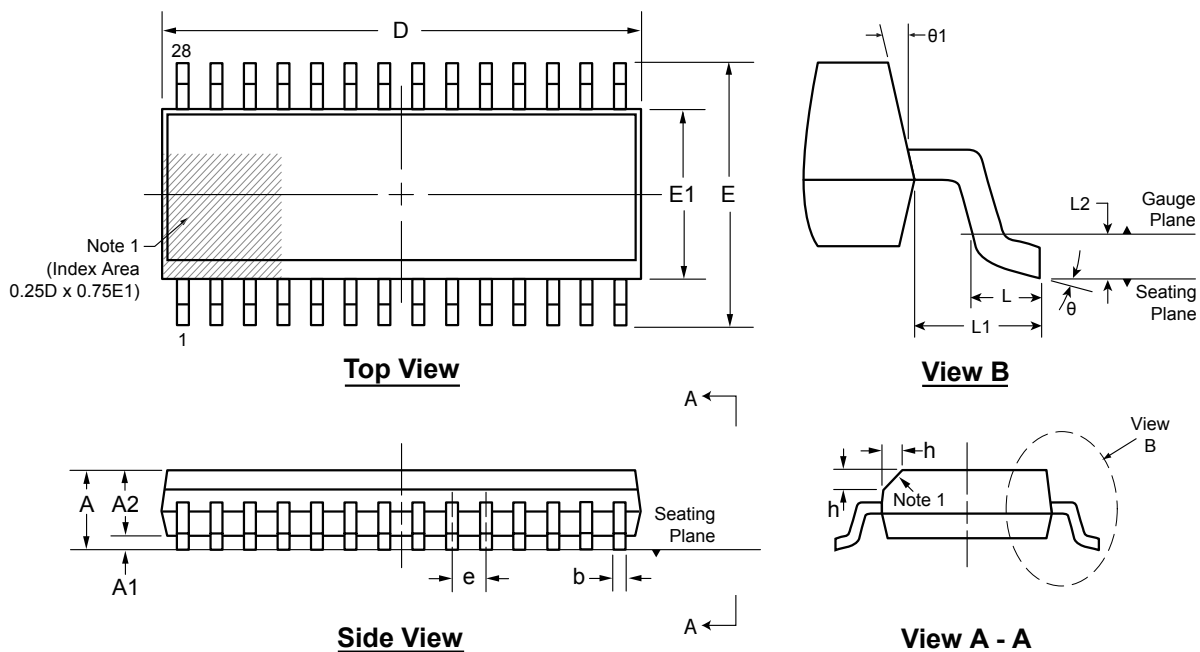

Note: For the most current package drawings, see the Microchip Packaging Specification at [www.microchip.com/packaging](http://www.microchip.com/packaging).

**Note:**

1. A Pin 1 identifier must be located in the index area indicated. The Pin 1 identifier can be: a molded mark/identifier; an embedded metal marker; or a printed indicator.

Symbol		A	A1	A2	b	D	E	E1	e	h	L	L1	L2	θ	θ1
Dimension (mm)	MIN	2.15*	0.10	2.05	0.31	17.70*	9.97*	7.40*	1.27 BSC	0.25	0.40	1.40 REF	0.25 BSC	0°	5°
	NOM	-	-	-	-	17.90	10.30	7.50		-	-			-	-
	MAX	2.65	0.30	2.55*	0.51	18.10*	10.63*	7.60*		0.75	1.27			8°	15°

JEDEC Registration MS-013, Variation AE, Issue E, Sep. 2005.

\* This dimension is not specified in the JEDEC drawing.

Drawings are not to scale.

---

---

**Package Outlines and Dimensions**

---

---

**TO-39**

Supertex Legacy

**Package Outlines and Dimensions**

**3-Lead TO-39 Package Outline (N2)**

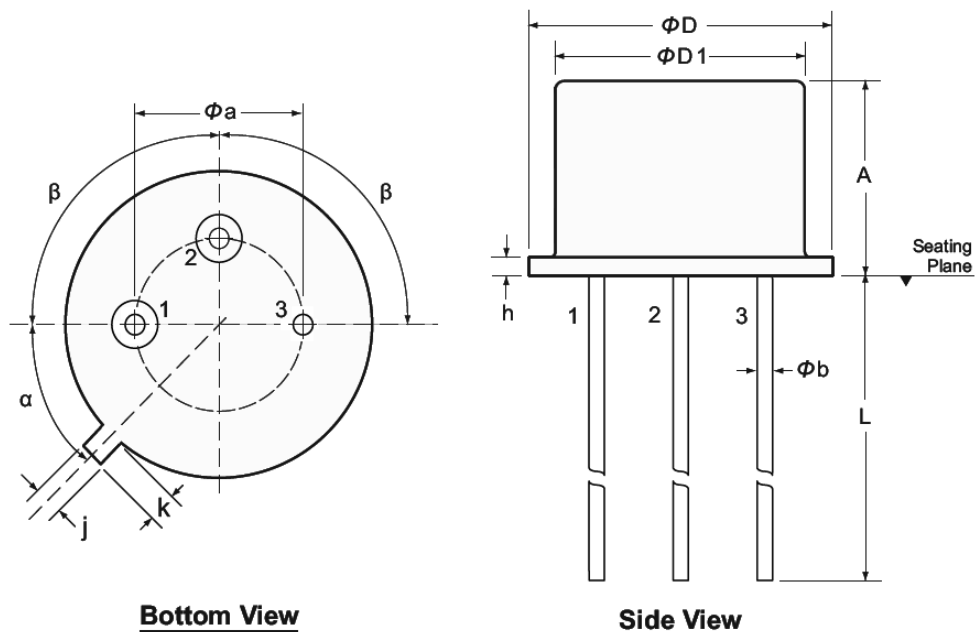

Note: For the most current package drawings, see the Microchip Packaging Specification at [www.microchip.com/packaging](http://www.microchip.com/packaging).

Symbol		$\alpha$	$\beta$	A	$\phi a$	$\phi b$	$\phi D$	$\phi D1$	h	j	k	L	
Dimension (inches)	MIN	45° NOM	90° NOM	.240	.190	.016	.350	.315	.009	.028	.029	.500	
	NOM			-	-	-	-	-	-	-	-	-	-
	MAX			.260	.210	.021	.370	.335	.125	.034	.040	.560*	

JEDEC Registration TO-39.

\* This dimension is not specified in the JEDEC drawing.

Drawings not to scale.

---

---

**Package Outlines and Dimensions**

---

---

**TO-92**

Supertex Legacy

**Package Outlines and Dimensions**

**3-Lead TO-92 Package Outline (L/LL/N3)**

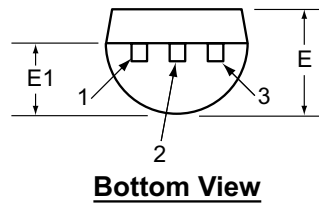
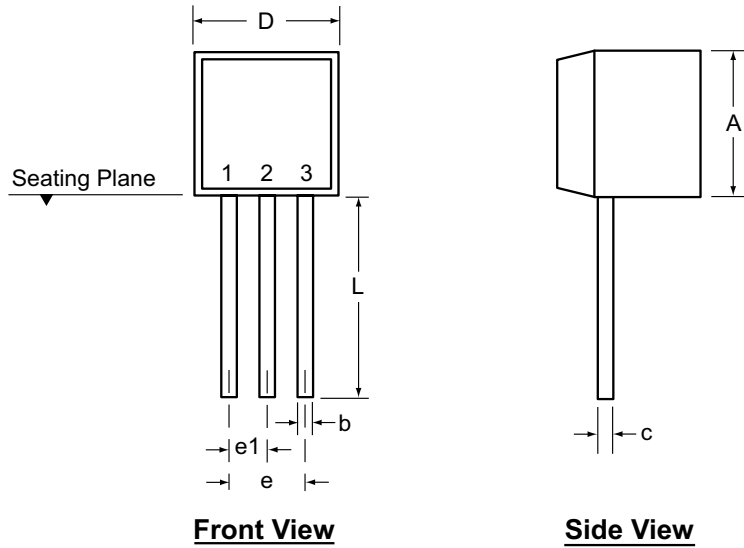

Note: For the most current package drawings, see the Microchip Packaging Specification at [www.microchip.com/packaging](http://www.microchip.com/packaging).

Symbol	A	b	c	D	E	E1	e	e1	L	
Dimensions (inches)	MIN	.170	.014 <sup>†</sup>	.014 <sup>†</sup>	.175	.125	.080	.095	.045	.500
	NOM	-	-	-	-	-	-	-	-	-
	MAX	.210	.022 <sup>†</sup>	.022 <sup>†</sup>	.205	.165	.105	.105	.055	.610*

JEDEC Registration TO-92.

\* This dimension is not specified in the JEDEC drawing.

† This dimension differs from the JEDEC drawing.

Drawings not to scale.



---



---

## Package Outlines and Dimensions

---



---

### 3-Lead TO-92 Package Outline (L/LL/N3)

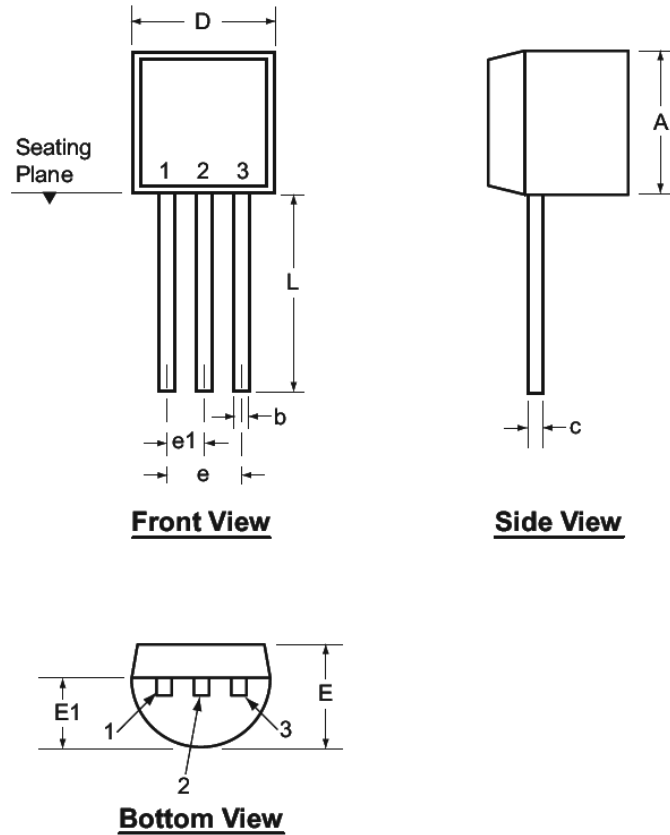

Note: For the most current package drawings, see the Microchip Packaging Specification at [www.microchip.com/packaging](http://www.microchip.com/packaging).

Symbol	A	b	c	D	E	E1	e	e1	L	
Dimensions (inches)	MIN	.170	.014 <sup>†</sup>	.014 <sup>†</sup>	.175	.125	.080	.095	.045	.500
	NOM	-	-	-	-	-	-	-	-	-
	MAX	.210	.022 <sup>†</sup>	.022 <sup>†</sup>	.205	.165	.105	.105	.055	.610*

JEDEC Registration TO-92.

\* This dimension is not specified in the JEDEC drawing.

† This dimension differs from the JEDEC drawing.

Drawings not to scale.



**MICROCHIP**

---

---

**Package Outlines and Dimensions**

---

---

**NOTES:**

---

---

**Package Outlines and Dimensions**

---

---

**TO-220**

Supertex Legacy

**Package Outlines and Dimensions**

**3-Lead TO-220 Package Outline (N5)**

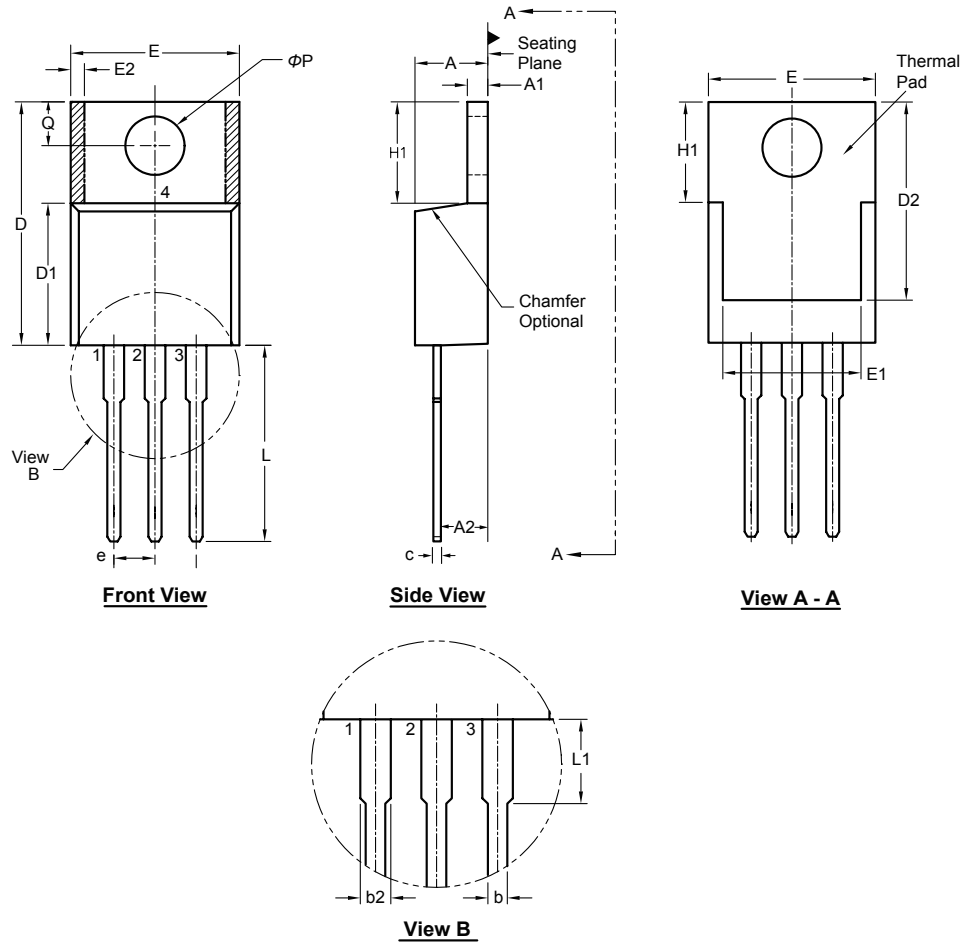

Note: For the most current package drawings, see the Microchip Packaging Specification at [www.microchip.com/packaging](http://www.microchip.com/packaging).

Symbol	A	A1	A2	b	b2	c	D	D1	D2	E	E1	E2	e	H1	L	L1	Q	$\phi P$		
Dimension (inches)	MIN	.140	.020	.080	.015	.045	.012†	.560	.326†	.474†	.380	.270	0.20*	.100 BSC	.230	.500	.200*	.100	.139	
	NOM	-	-	-	.027	.057	-	-	-	-	-	-	-		-	-	-	-	-	-
	MAX	.190	.055	.120†	.040	.070	.024	.650	.361†	.507	.420	.350	.030		.270	.580	.250	.135	.161	

JEDEC Registration TO-220, Variation AB, Issue K, April 2002.

\* This dimension is not specified in the JEDEC drawing.

† This dimension differs from the JEDEC drawing.

Drawings not to scale.

---



---

## Package Outlines and Dimensions

---



---

### 7-Lead TO-220 Package Outline (K2)

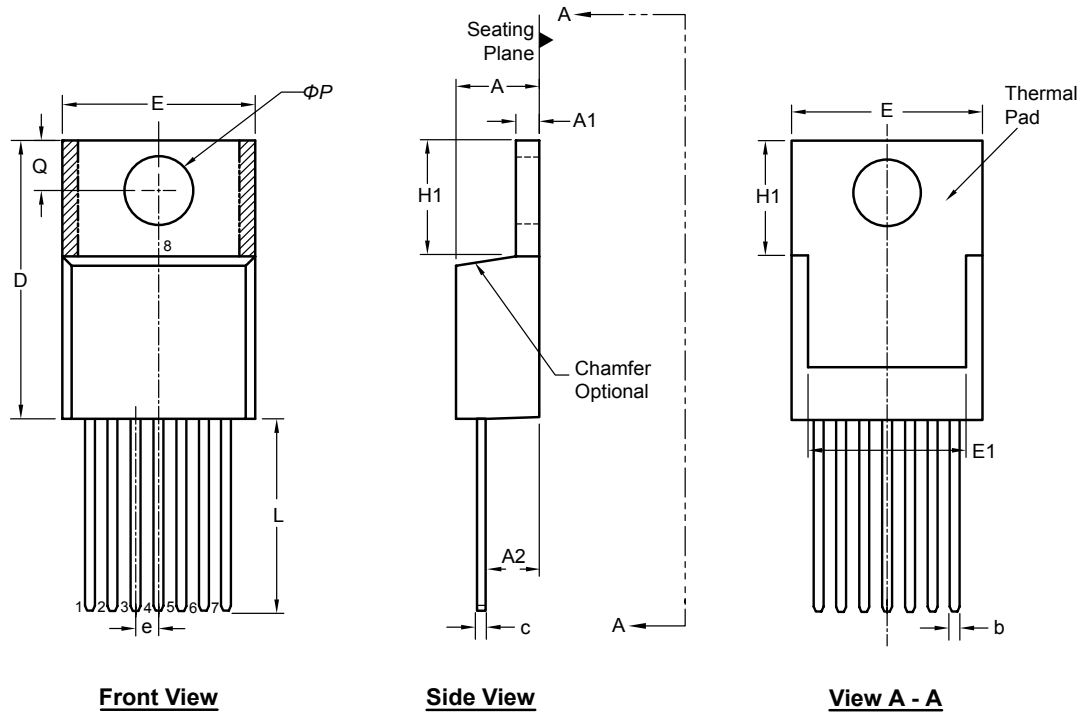

Note: For the most current package drawings, see the Microchip Packaging Specification at [www.microchip.com/packaging](http://www.microchip.com/packaging).

Symbol	A	A1	A2	b	c	D	E	E1	e	H1	L	Q	$\Phi P$		
Dimension (Inches)	MIN	.160	.045	.090	.023	.015	.560	.385	.300 REF	.045	.234	.540	.103	.146	
	NOM	-	-	-	-	-	-	-		-	-	-	-	-	-
	MAX	.190	.055	.115	.037	.022	.590	.415		.055	.258	.560	.113	.156	

*Drawings not to scale.*



**MICROCHIP**

---

---

**Package Outlines and Dimensions**

---

---

NOTES:

---

---

**Package Outlines and Dimensions**

---

---

**TO-243**

Supertex Legacy

**Package Outlines and Dimensions**

**3-Lead TO-243AA (SOT-89) Package Outline (N8)**

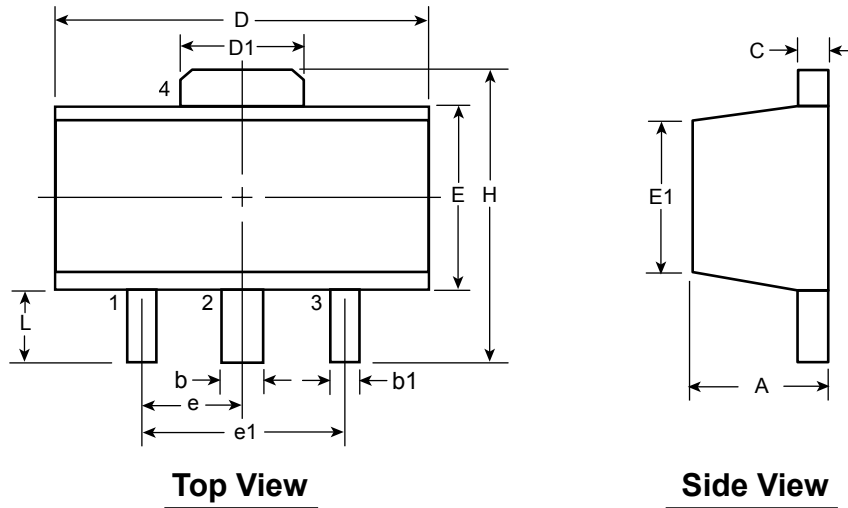

Note: For the most current package drawings, see the Microchip Packaging Specification at [www.microchip.com/packaging](http://www.microchip.com/packaging).

Symbol	A	b	b1	C	D	D1	E	E1	e	e1	H	L		
Dimensions (mm)	MIN	1.40	0.44	0.36	0.35	4.40	1.62	2.29	2.00†	1.50 BSC	3.00 BSC	3.94	0.73†	
	NOM	-	-	-	-	-	-	-	-			-	-	-
	MAX	1.60	0.56	0.48	0.44	4.60	1.83	2.60	2.29			4.25	1.20	

JEDEC Registration TO-243, Variation AA, Issue C, July 1986.

† This dimension differs from the JEDEC drawing

Drawings not to scale.



---

---

**Package Outlines and Dimensions**

---

---

**TO-252**

Supertex Legacy

**Package Outlines and Dimensions**

**3-Lead TO-252 (D-PAK) Package Outline (K4)**

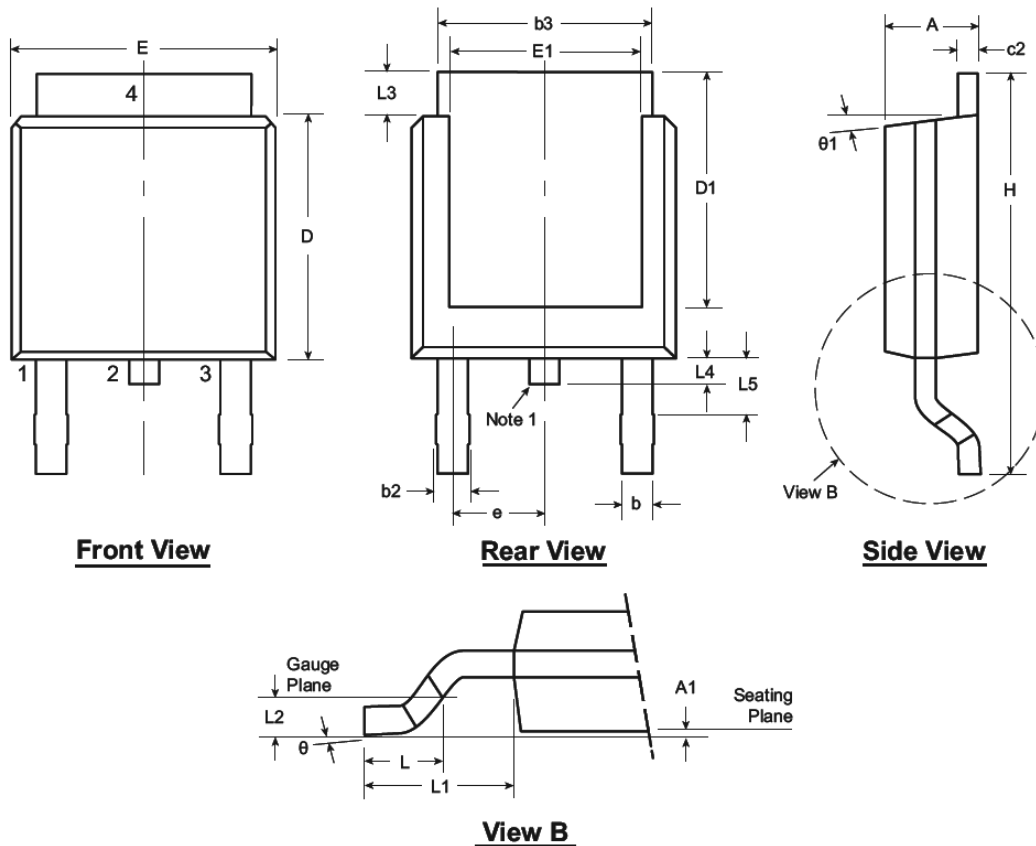

Note: For the most current package drawings, see the Microchip Packaging Specification at [www.microchip.com/packaging](http://www.microchip.com/packaging).

**Note:**

- Although 4 terminal locations are shown, only 3 are functional. Lead number 2 was removed.

Symbol	A	A1	b	b2	b3	c2	D	D1	E	E1	e	H	L	L1	L2	L3	L4	L5	$\theta$	$\theta1$			
Dimension (inches)	MIN	.086	.000*	.025	.030	.195	.235	.205	.250	.170	.090 BSC	.370	.055	.108 REF	.020 BSC	.035	.025*	.035†	0°	0°			
	NOM	-	-	-	-	-	.240	-	-	-		-	.060			-	-	-	-	-	-	-	-
	MAX	.094	.005	.035	.045	.215	.035	.245	.217*	.265		.200*	.410			.070	-	-	.050	.040	.060	10°	15°

JEDEC Registration TO-252, Variation AA, Issue E, June 2004.

\* This dimension is not specified in the JEDEC drawing.

† This dimension differs from the JEDEC drawing.

Drawings not to scale.

---

---

**Package Outlines and Dimensions**

---

---

**TQFP**

Supertex Legacy

## Package Outlines and Dimensions

### 128-Lead TQFP (w/Heat Slug) Package Outline (HF)

14.00x14.00mm body, 1.20mm height (max), 0.40mm pitch

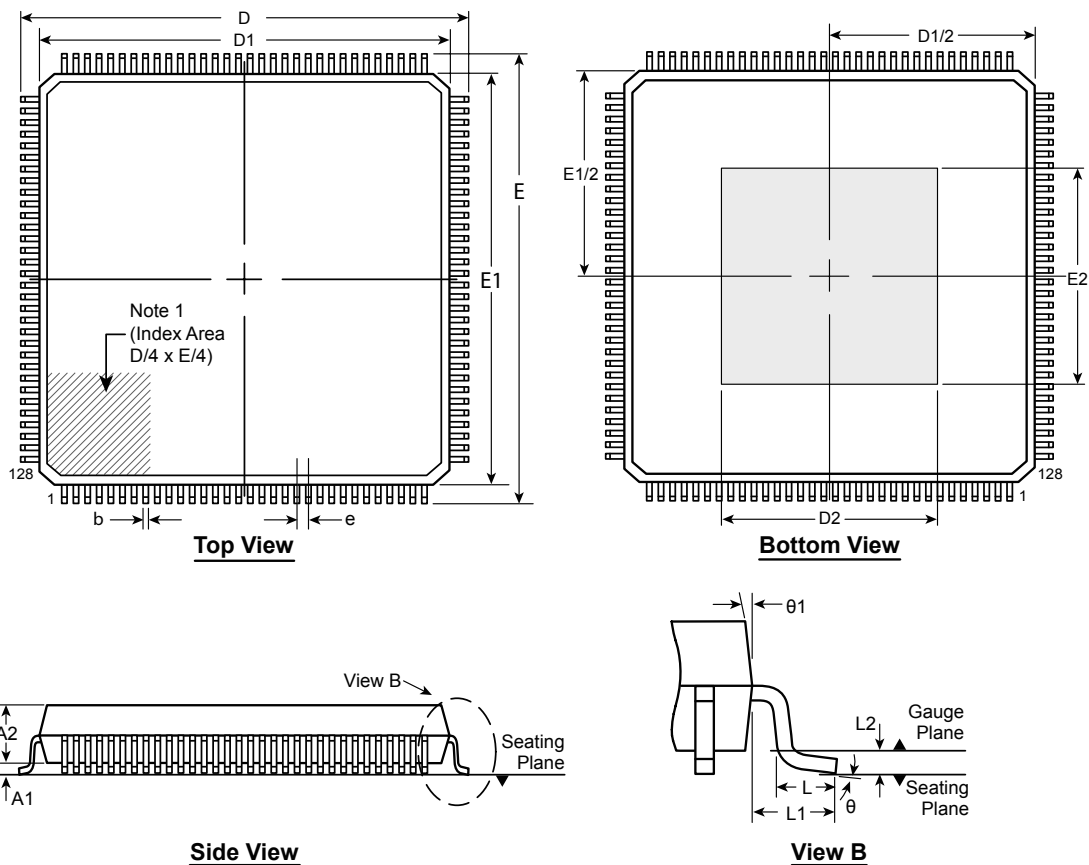

Note: For the most current package drawings, see the Microchip Packaging Specification at [www.microchip.com/packaging](http://www.microchip.com/packaging).

**Note:**

1. A Pin 1 identifier must be located in the index area indicated. The Pin 1 identifier can be: a molded mark/identifier; an embedded metal marker; or a printed indicator.

Symbol	A	A1	A2	b	D	D1	D2	E	E1	E2	e	L	L1	L2	$\theta$	$\theta 1$	
Dimension (mm)	MIN	-	0.05	0.95	0.13	16.00	14.00	9.50	16.00	14.00	9.50	0.40	0.45	1.00	0.25	0°	11°
	NOM	-	-	1.00	0.18	BSC	BSC	BSC	BSC	BSC	BSC	BSC	0.60	REF	BSC	3.5°	12°
	MAX	1.20	0.15	1.05	0.23								0.75			7°	13°

Drawings not to scale.

---

---

**Package Outlines and Dimensions**

---

---

**TSSOP**

Supertex Legacy

**Package Outlines and Dimensions**

**24-Lead TSSOP Package Outline (TS)**  
**7.80x4.40mm body, 1.20mm height (max), 0.65mm pitch**

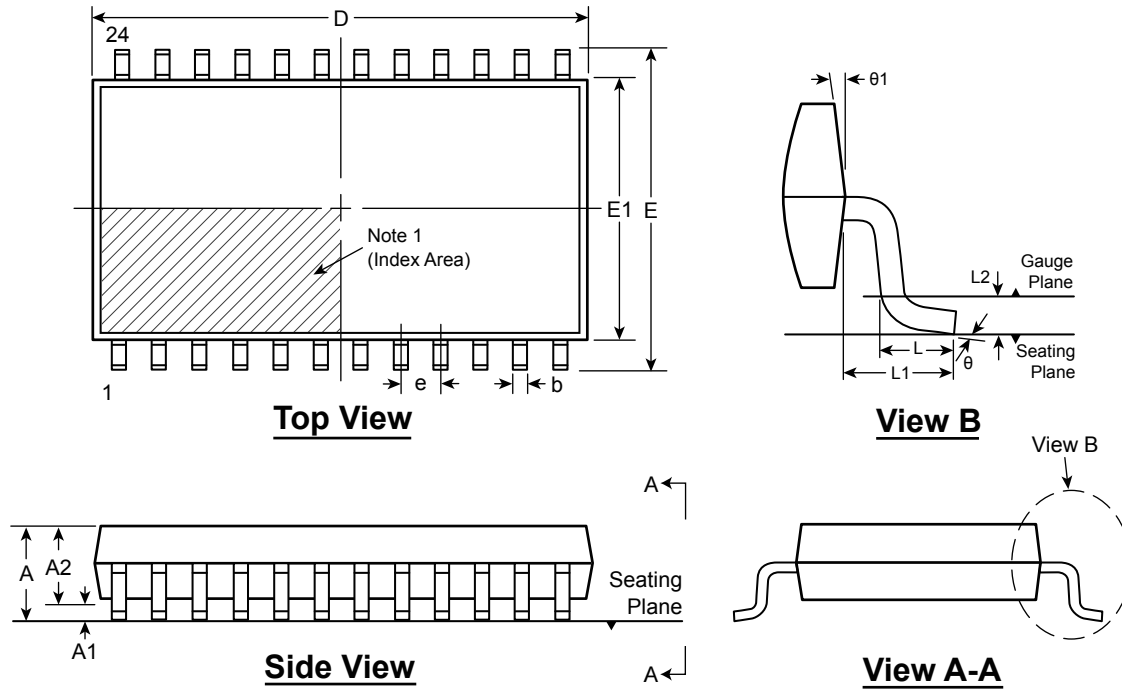

Note: For the most current package drawings, see the Microchip Packaging Specification at [www.microchip.com/packaging](http://www.microchip.com/packaging).

**Note:**

1. A Pin 1 identifier must be located in the index area indicated. The Pin 1 identifier can be: a molded mark/identifier; an embedded metal marker; or a printed indicator.

Symbol	A	A1	A2	b	D	E	E1	e	L	L1	L2	$\theta$	$\theta1$		
Dimension (mm)	MIN	0.85*	0.05	0.80	0.19	7.70	6.20*	4.30	0.65 BSC	0.45	1.00 REF	0.25	0°	12° REF	
	NOM	-	-	1.00	-	7.80	6.40	4.40		0.60		BSC			-
	MAX	1.20	0.15	1.15†	0.30	7.90	6.60*	4.50		0.75		BSC			8°

JEDEC Registration MS-153, Variation AD, Issue F, May 2001.

\* This dimension is not specified in the JEDEC drawing.

† This dimension differs from the JEDEC drawing.

Drawings are not to scale.

## **Legacy Micrel Package Drawings & Specifications**



**MICROCHIP**

---

---

**Package Outlines and Dimensions**

---

---

**NOTES:**



---

---

**Package Outlines and Dimensions**

---

---

**CDFN**

Micrel Legacy

**Package Outlines and Dimensions**

**TITLE**

4 LEAD CDFN 5.0x3.2mm COL PACKAGE OUTLINE & RECOMMENDED LAND PATTERN

<b>DRAWING #</b>	CDFN5032-4LD-PL-1	<b>UNIT</b>	MM
------------------	-------------------	-------------	----

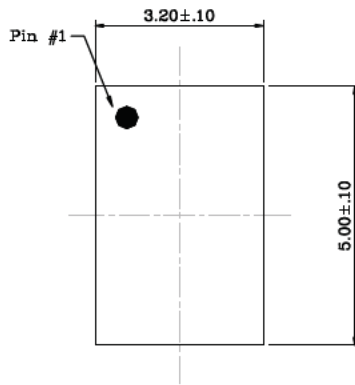

Top View

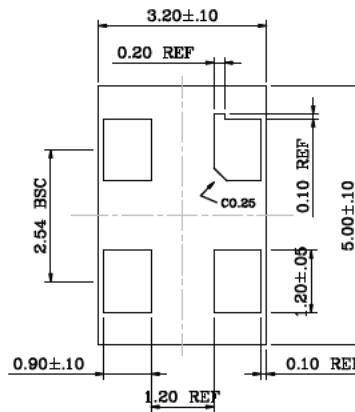

Bottom View

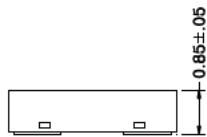

Side View

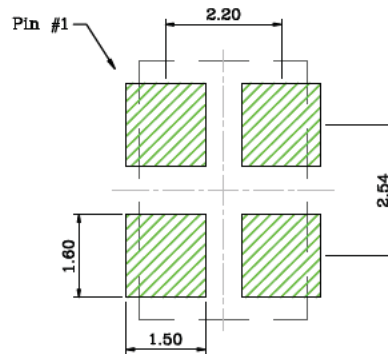

Recommended Land Pattern

**NOTE:**

- Green shaded rectangles in Recommended Land Pattern are solder stencil opening.

Note: For the most current package drawings, please see the Microchip Packaging Specification located at <http://www.microchip.com/packaging>.

**Package Outlines and Dimensions**

**TITLE**

4 LEAD CDFN 3.2x2.5mm COL PACKAGE OUTLINE & RECOMMENDED LAND PATTERN

DRAWING #	CDFN3225-4LD-PL-1	UNIT	MM
-----------	-------------------	------	----

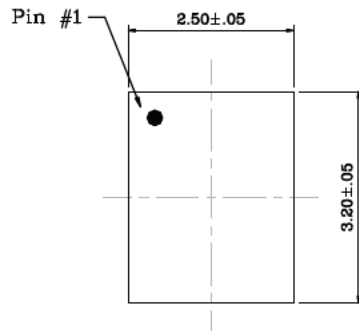

Top View

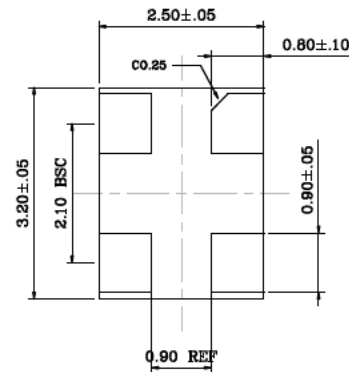

Bottom View

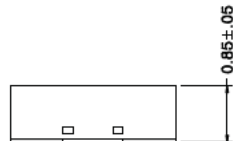

Side View

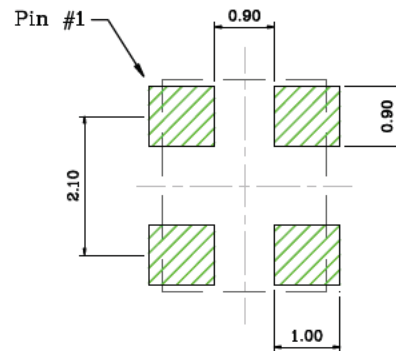

Recommended Land Pattern

**NOTE:**

- Green shaded rectangles in Recommended Land Pattern are solder stencil opening.

Note: For the most current package drawings, please see the Microchip Packaging Specification located at <http://www.microchip.com/packaging>.

**Package Outlines and Dimensions**

**TITLE**

4 LEAD CDFN 2.5x2.0mm COL PACKAGE OUTLINE & RECOMMENDED LAND PATTERN

DRAWING #	CDFN2520-4LD-PL-1	UNIT	MM
-----------	-------------------	------	----

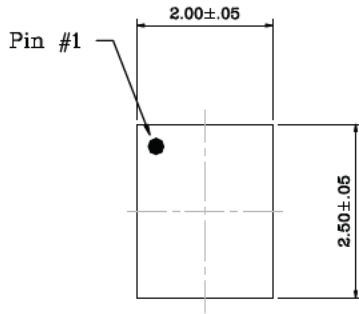

Top View

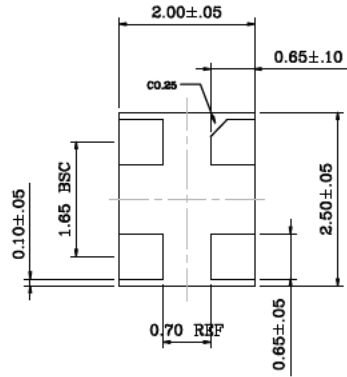

Bottom View

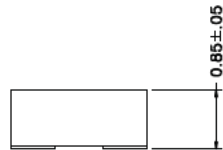

Side View

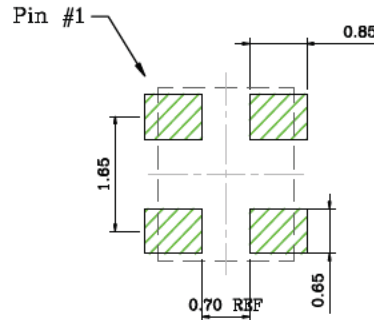

Recommended Land Pattern

**NOTE:**

- Green shaded rectangles in Recommended Land Pattern are solder stencil opening.

Note: For the most current package drawings, please see the Microchip Packaging Specification located at <http://www.microchip.com/packaging>.

---



---

## Package Outlines and Dimensions

---



---

**TITLE**

6 LEAD CDFN 7.0x5.0mm COL PACKAGE OUTLINE &amp; RECOMMENDED LAND PATTERN

<b>DRAWING #</b>	CDFN75-6LD-PL-1	<b>UNIT</b>	MM
------------------	-----------------	-------------	----

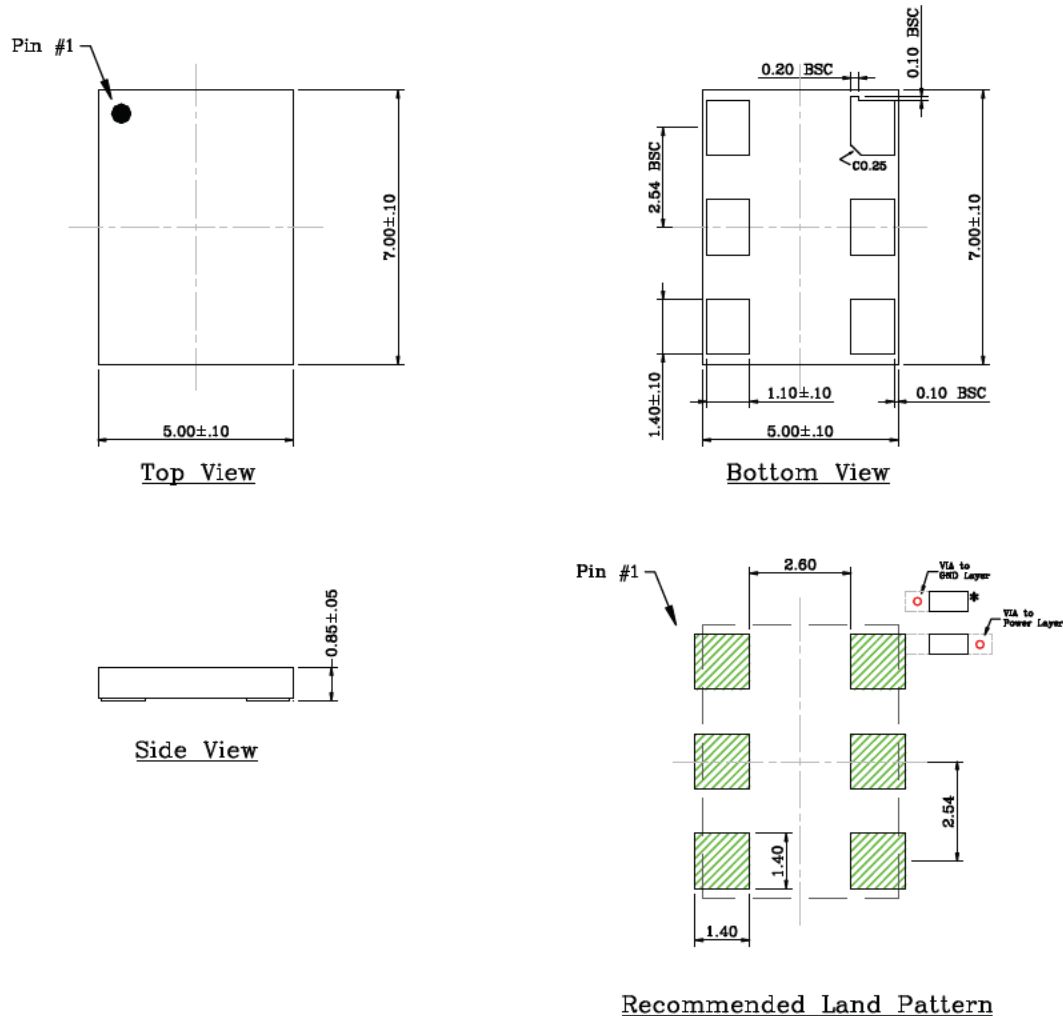
**NOTE:**

1. \* Power Supply Decoupling Capacitor is required in Recommended Land Pattern.
2. Green shaded rectangles in Recommended Land Pattern are solder stencil opening.
3. Red circles in Recommended Land Pattern are thermal VIA.

Note: For the most current package drawings, please see the Microchip Packaging Specification located at <http://www.microchip.com/packaging>.

**Package Outlines and Dimensions**

**TITLE**

6 LEAD CDFN 2.5x2.0mm COL PACKAGE OUTLINE & RECOMMENDED LAND PATTERN

DRAWING #	CDFN2520-6LD-PL-1	UNIT	MM
-----------	-------------------	------	----

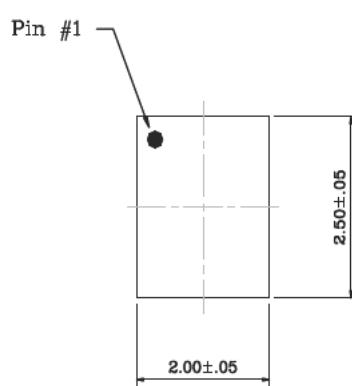

Top View

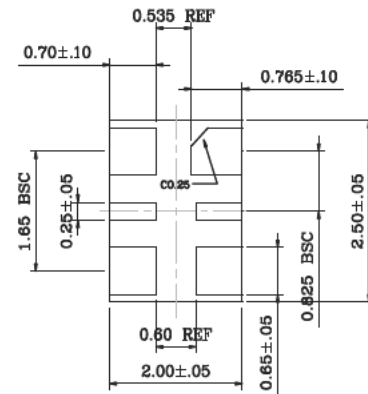

Bottom View



Side View

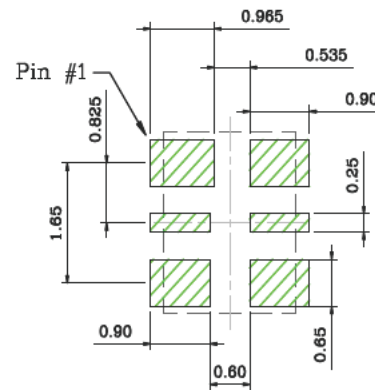

Recommended Land Pattern

**NOTE:**

- Green shaded rectangles in Recommended Land Pattern are solder stencil opening.

Note: For the most current package drawings, please see the Microchip Packaging Specification located at <http://www.microchip.com/packaging>.

## Package Outlines and Dimensions

**TITLE**

6 LEAD CDFN 3.2x2.5mm COL PACKAGE OUTLINE & RECOMMENDED LAND PATTERN

DRAWING #	CDFN3225-6LD-PL-1	UNIT	MM
-----------	-------------------	------	----

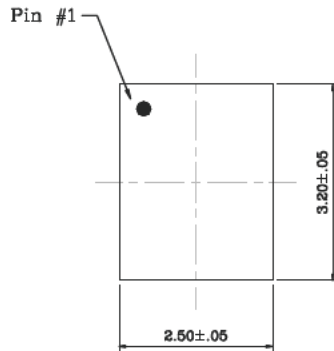

Top View

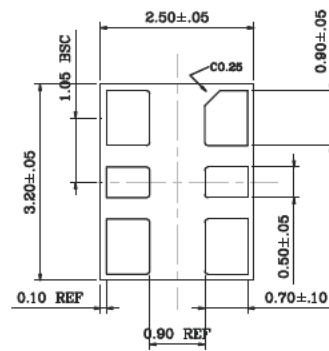

Bottom View



Side View

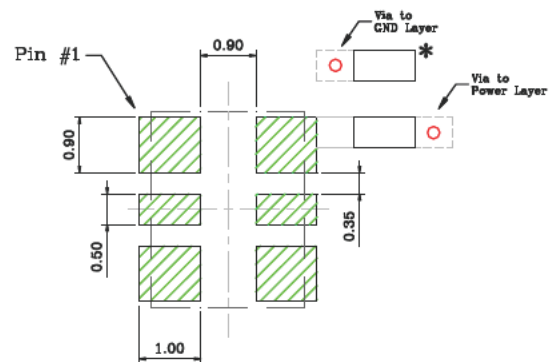

Recommended Land Pattern

**NOTE:**

1. \* Power Supply Decoupling Capacitor is required in Recommended Land Pattern.
2. Green shaded rectangles in Recommended Land Pattern are solder stencil opening.
3. Red circles in Recommended Land Pattern are thermal VIA.

Note: For the most current package drawings, please see the Microchip Packaging Specification located at <http://www.microchip.com/packaging>.

## Package Outlines and Dimensions

### TITLE

6 LEAD CDFN 5.0x3.2mm COL PACKAGE OUTLINE & RECOMMENDED LAND PATTERN

DRAWING #	CDFN5032-6LD-PL-1	UNIT	MM
-----------	-------------------	------	----

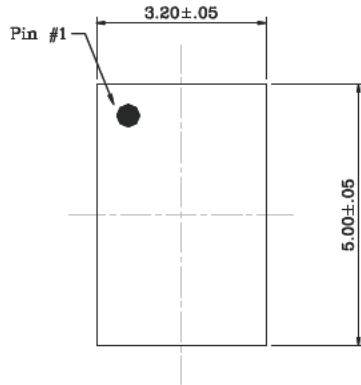

Top View

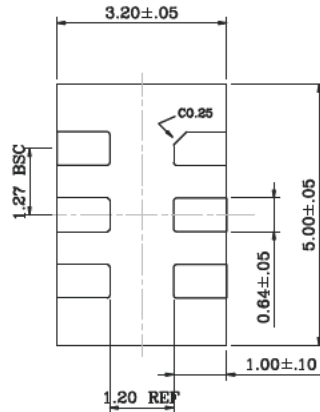

Bottom View



Side View

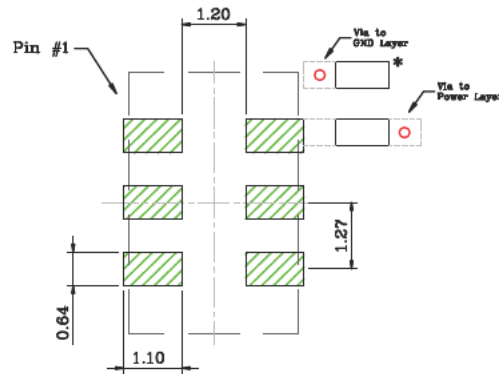

Recommended Land Pattern

### NOTE:

- \* Power Supply Decoupling Capacitor is required in Recommended Land Pattern.
- Green shaded rectangles in Recommended Land Pattern are solder stencil opening.
- Red circles in Recommended Land Pattern are thermal VIA.

Note: For the most current package drawings, please see the Microchip Packaging Specification located at <http://www.microchip.com/packaging>.



---

---

**Package Outlines and Dimensions**

---

---

**CERQUAD**

Micrel Legacy

**Package Outlines and Dimensions**

**TITLE**

32 LEAD CERAMIC QUAD PACKAGE OUTLINE & RECOMMENDED LAND PATTERN

DRAWING #	CERQUAD-32LD-PL-1	UNIT	INCH (MM)
MATERIAL TYPE	Ceramic Al2O3	Lead Finish	Solder plated

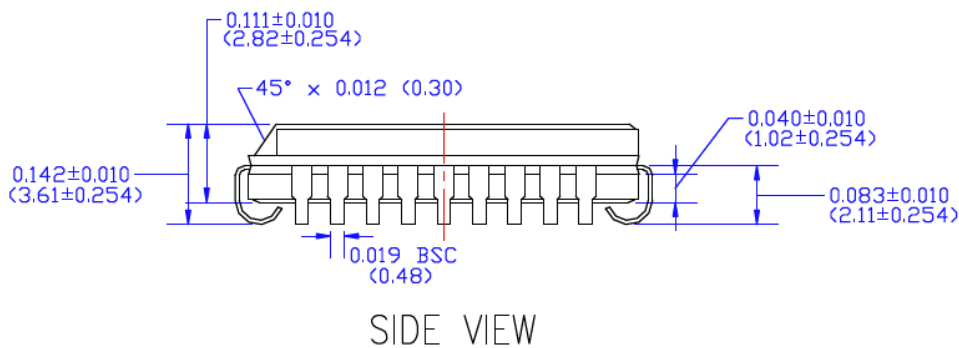
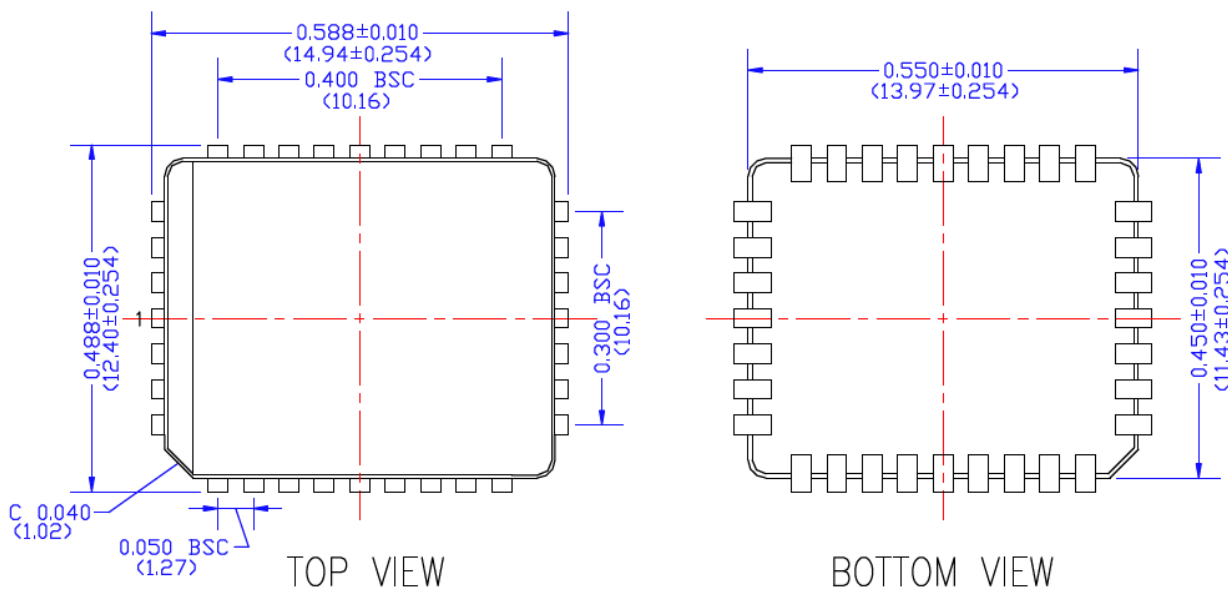

**Note:**

1. Reference to MIL-STD-1835
2. Drawing not to scale
3. Dimensions on drawing are reference only.
4. Chip or crack on package body is not allowed.
5. Base material supplier is KYOCERA, Japan.
6. Package lead coplanarity is +/- 0.004 mils (0.100 mm).

Note: For the most current package drawings, please see the Microchip Packaging Specification located at <http://www.microchip.com/packaging>.

---



---

**Footprint Outlines and Dimensions**

---



---

POD-Land Pattern drawing # CERQUAD-32LD-PL-1

RECOMMENDED LAND PATTERN

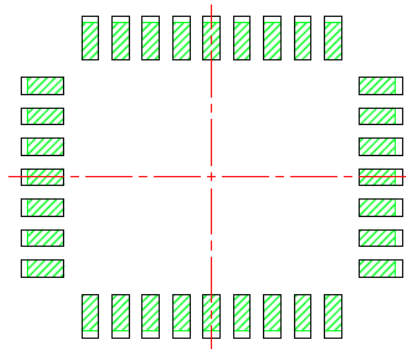

STACKED-UP

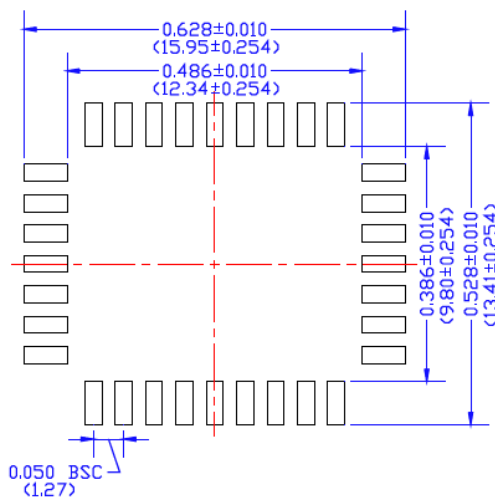

EXPOSED METAL TRACE

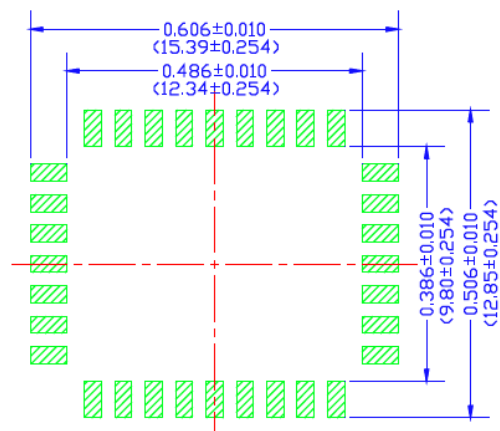

SOLDER STENCIL OPENING

Note: For the most current package drawings, please see the Microchip Packaging Specification located at <http://www.microchip.com/packaging>.



**MICROCHIP**

---

---

**Package Outlines and Dimensions**

---

---

**NOTES:**

---

---

**Package Outlines and Dimensions**

---

---

**CERSiP**

Micrel Legacy

**Package Outlines and Dimensions**

**6-Lead Ceramic System In Package (AC) - 5x7x1.62mm Body [CERSiP]  
Micrel Legacy "Module"**

**Note:** For the most current package drawings, please see the Microchip Packaging Specification located at <http://www.microchip.com/packaging>

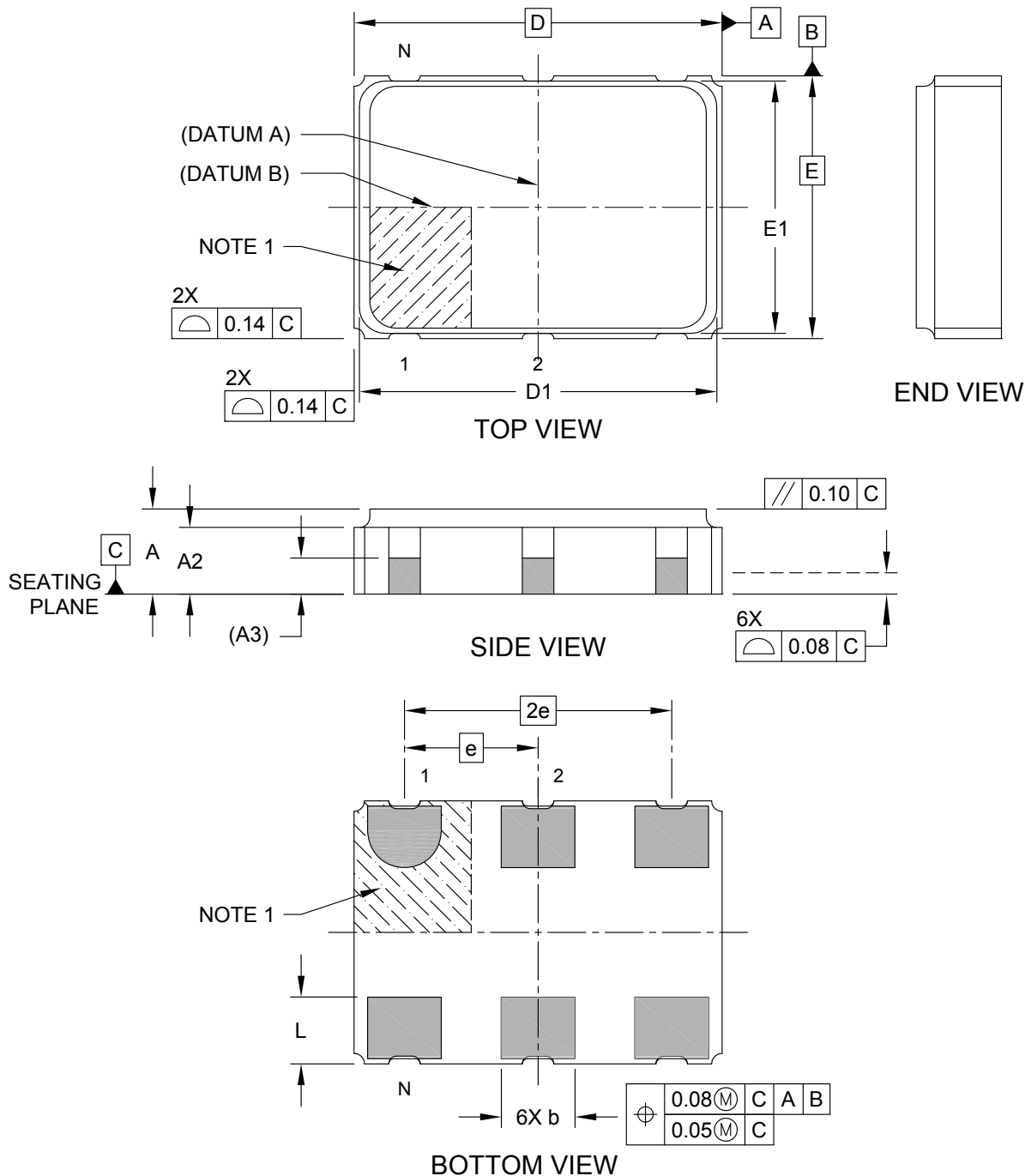

## Package Outlines and Dimensions

### 6-Lead Ceramic System In Package (AC) - 5x7x1.62mm Body [CERSiP] Micrel Legacy "Module"

**Note:** For the most current package drawings, please see the Microchip Packaging Specification located at <http://www.microchip.com/packaging>

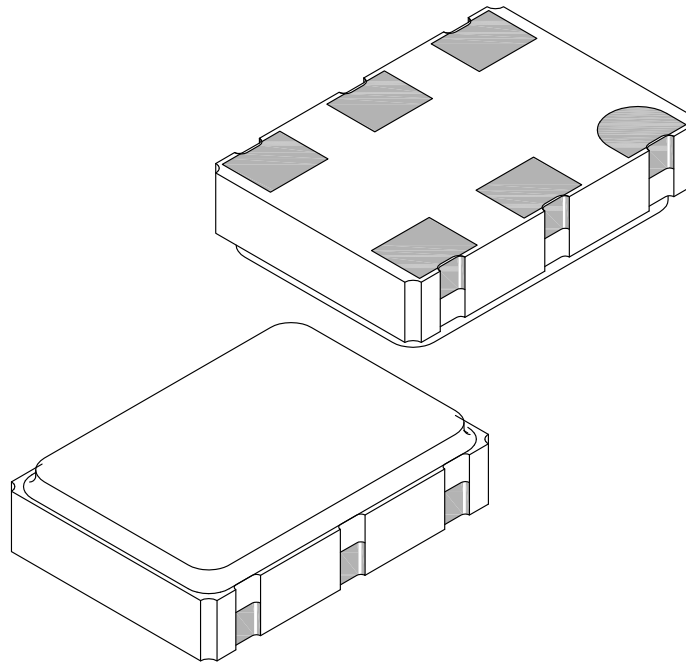

Dimension	Units	MILLIMETERS		
		MIN	NOM	MAX
Number of Terminals	N	6		
Pitch	e	2.54 BSC		
Overall Height	A	1.47	1.62	1.77
Ceramic Base Height	A2	1.17	1.27	1.37
Terminal Thickness	A3	0.69 REF		
Overall Length	D	7.00 BSC		
Lid Length	D1	6.70	6.80	6.90
Overall Width	E	5.00 BSC		
Lid Width	E1	4.70	4.80	4.90
Terminal Width	b	1.30	1.40	1.50
Terminal Length	L	1.17	1.27	1.37

**Notes:**

1. Pin 1 visual index feature may vary, but must be located within the hatched area.
2. Dimensioning and tolerancing per ASME Y14.5M
  - BSC: Basic Dimension. Theoretically exact value shown without tolerances.
  - REF: Reference Dimension, usually without tolerance, for information purposes only.

## Package Outlines and Dimensions

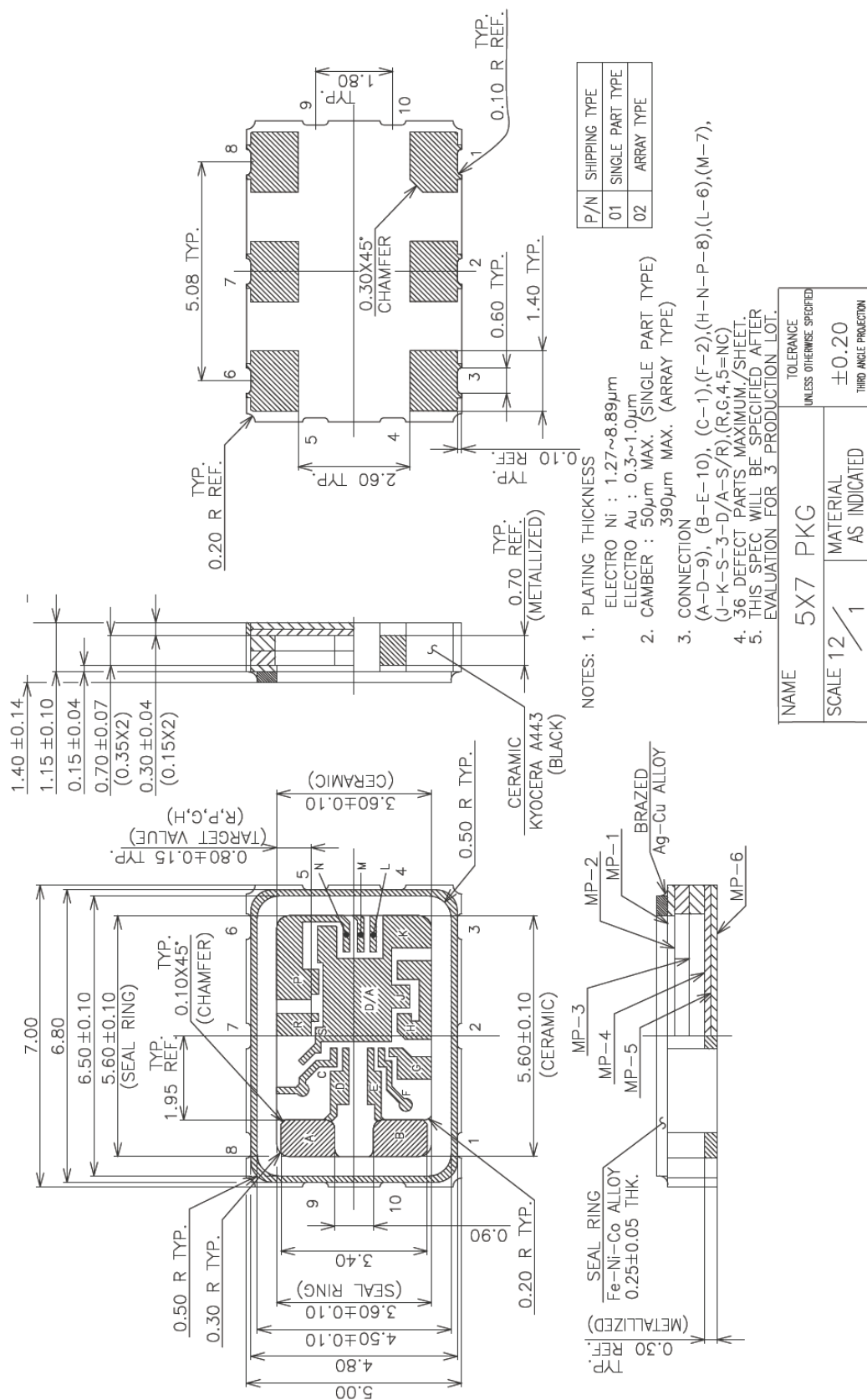

Note: For the most current package drawings, please see the Microchip Packaging Specification located at <http://www.microchip.com/packaging>.



**Package Outlines and Dimensions**

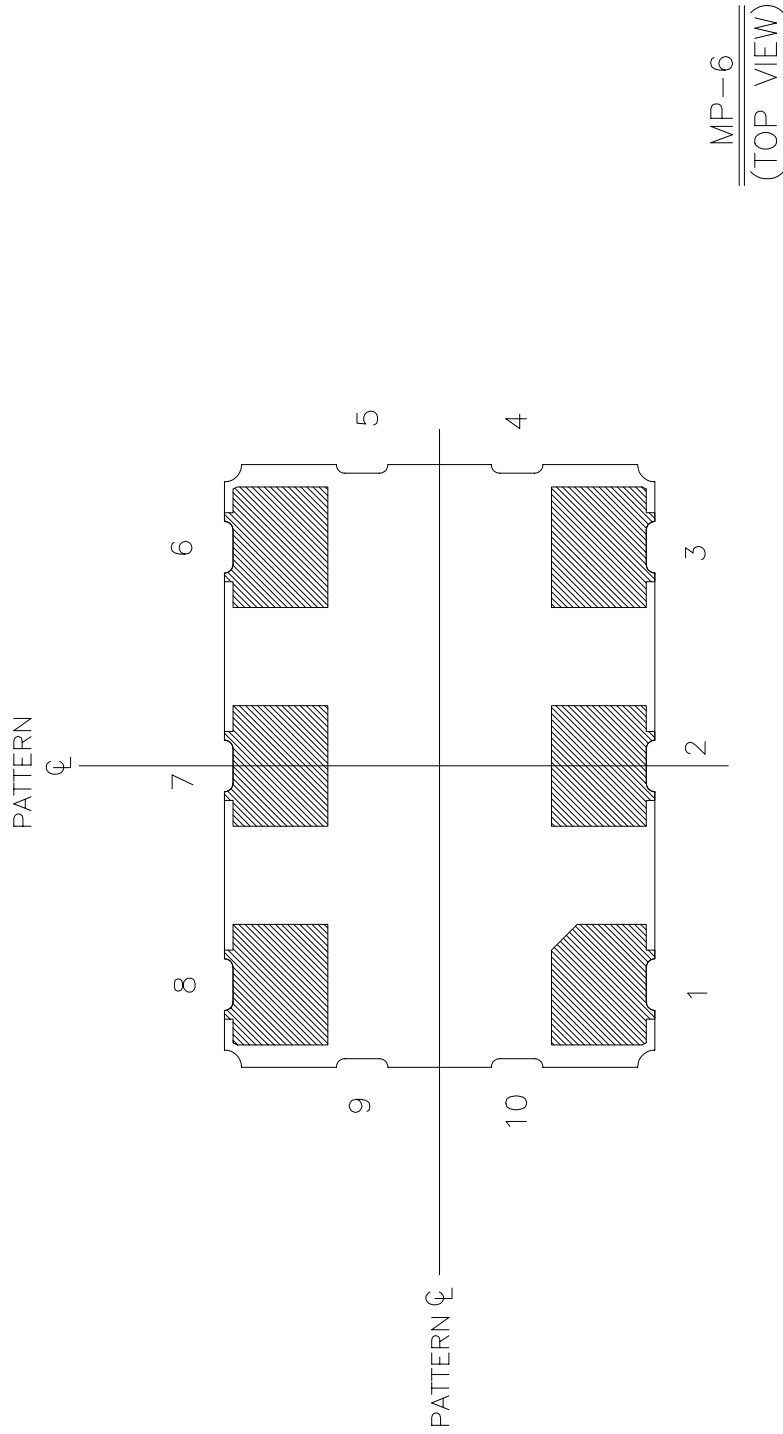

Note: For the most current package drawings, please see the Microchip Packaging Specification located at <http://www.microchip.com/packaging>.



**MICROCHIP**

---

---

**Package Outlines and Dimensions**

---

---

NOTES:

---

---

**Package Outlines and Dimensions**

---

---

**CLLCC**

Micrel Legacy

## Package Outlines and Dimensions

### TITLE

6 LEAD CLLCC 7x5 mm PACKAGE OUTLINE & RECOMMENDED LAND PATTERN

<b>DRAWING #</b>	CLLCC75-6LD-PL-1	<b>UNIT</b>	MM
------------------	------------------	-------------	----

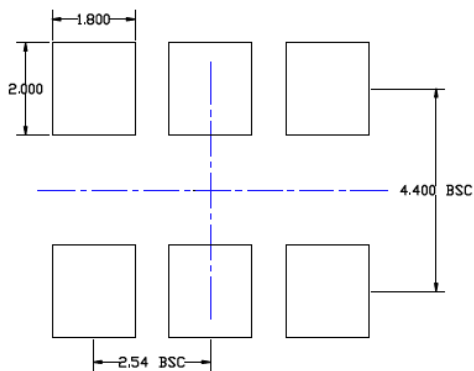
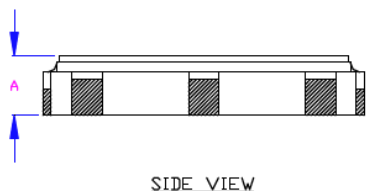
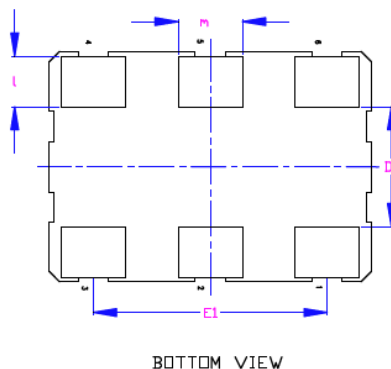
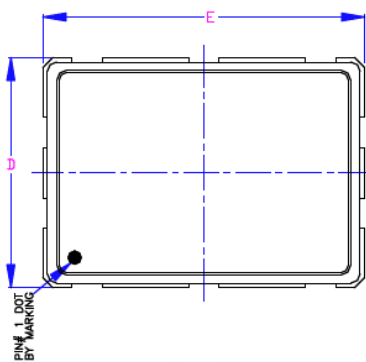

Dimensional Ref.			
REF.	Min.	Nom.	Max.
A	1.100	1.300	1.500
D	4.800	5.000	5.200
D1	2.600 BSC		
E	6.800	7.000	7.200
E1	5.080 BSC		
l	0.900	1.100	1.300
m	1.200	1.400	1.600
n	6		

### Notes

1. Dimensioning and Tolerancing per ASME Y14.5M-1994.
2. Dimensions are in millimeters.
3. 'n' is the maximum no. of Land for a specified Package.
4. Package warp shall be 0.050 max.
5. Substrate base is Ceramic.
6. The Pin#1 corner must be identified on top side only.
7. Pad dimension tolerance is +/- 0.12mm unless otherwise specified

Note: For the most current package drawings, please see the Microchip Packaging Specification located at <http://www.microchip.com/packaging>.

---

---

**Package Outlines and Dimensions**

---

---

**CQFN**

Micrel Legacy

## Package Outlines and Dimensions

### TITLE

16 LEAD QFN 3.0x3.0mm COL PACKAGE OUTLINE & RECOMMENDED LAND PATTERN

DRAWING #	CQFN33-16LD-PL-1	UNIT	MM
Lead Frame	NiPdAu	Lead Finish	NiPdAu

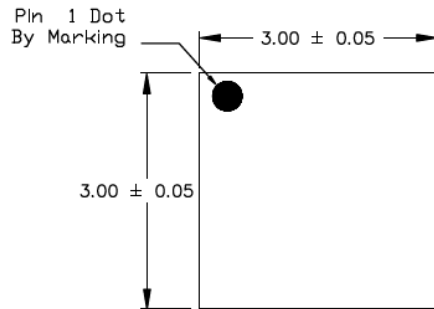

TOP VIEW

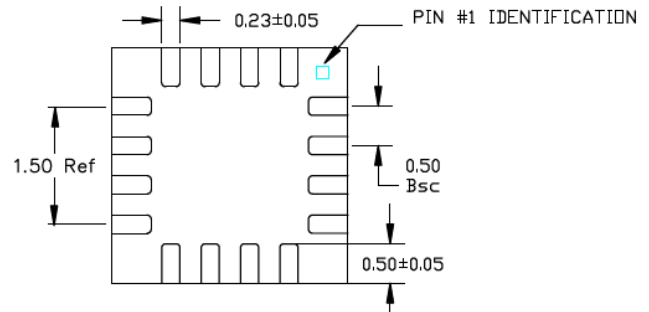

BOTTOM VIEW

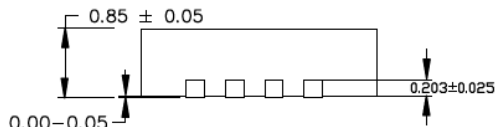

SIDE VIEW

### NOTES:

1. ALL DIMENSIONS ARE IN MILLIMETERS, ANGLES ARE IN DEGREES.  
N IS THE TOTAL NUMBER OF TERMINALS.
2. MAX PACKAGE WARPAGE IS 0.05mm, MAX ALLOWABLE BURRS IS 0.076 mm  
IN ALL DIRECTIONS.
3. PIN #1 ID ON TOP WILL BE LASER/INK MARKED.

Note: For the most current package drawings, please see the Microchip Packaging Specification located at <http://www.microchip.com/packaging>.

**Package Outlines and Dimensions**

POD-Land Pattern drawing #CQFN33-16LD-PL-1

RECOMMENDED LAND PATTERN

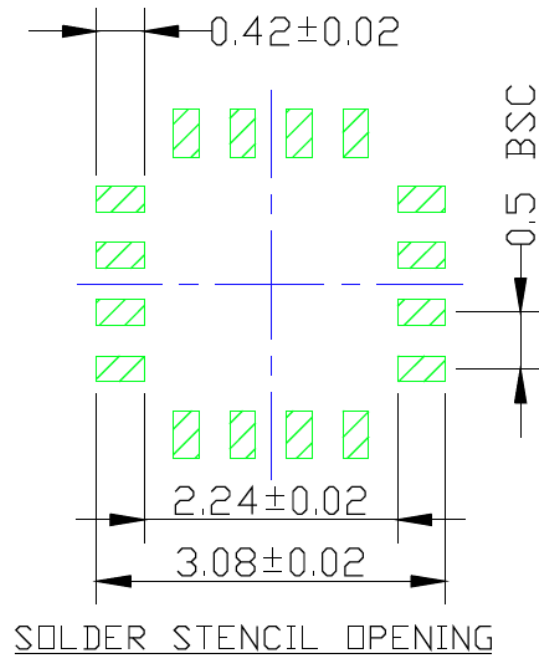
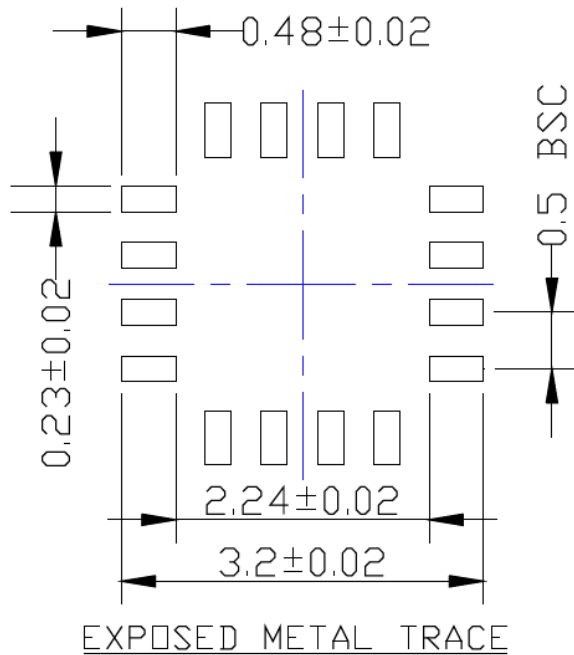
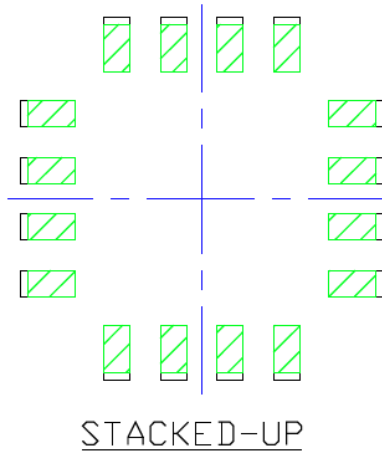

Note: For the most current package drawings, please see the Microchip Packaging Specification located at <http://www.microchip.com/packaging>.

## Package Outlines and Dimensions

### TITLE

17 LEAD COL QFN 2.5x2.8mm PACKAGE OUTLINE & RECOMMENDED LAND PATTERN

DRAWING #	CQFN2528-17LD-PL-1	UNIT	MM
-----------	--------------------	------	----

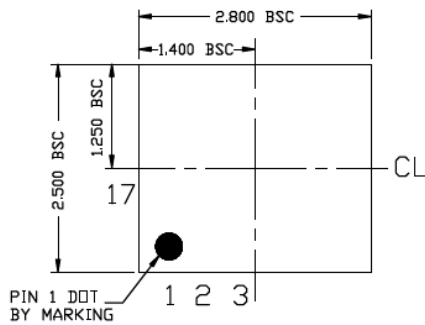

TOP VIEW

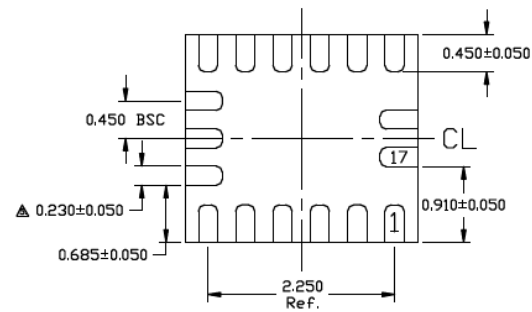

BOTTOM VIEW

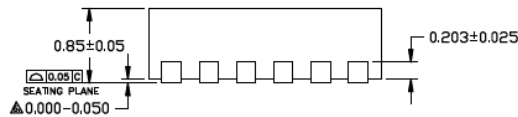

SIDE VIEW

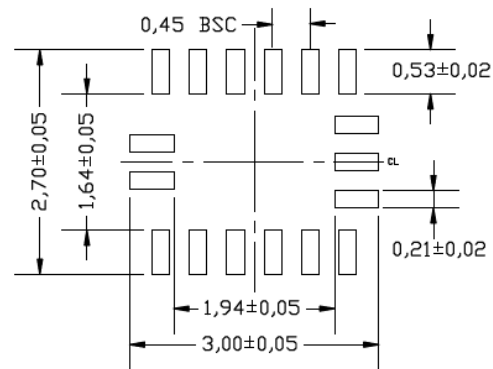

RECOMMENDED LAND PATTERN

### NOTE:

1. ALL DIMENSIONS ARE IN MILLIMETERS.
2. MAX. PACKAGE WARPAGE IS 0.05 mm.
3. MAXIMUM ALLOWABLE BURRS IS 0.076 mm IN ALL DIRECTIONS.
4. PIN #1 ID ON TOP WILL BE LASER/INK MARKED.
5. DIMENSION APPLIES TO METALIZED TERMINAL AND IS MEASURED BETWEEN 0.20 AND 0.25 mm FROM TERMINAL TIP.
6. APPLIED ONLY FOR TERMINALS.

Note: For the most current package drawings, please see the Microchip Packaging Specification located at <http://www.microchip.com/packaging>.



---

---

**Package Outlines and Dimensions**

---

---

**CTDFN**

Micrel Legacy

## Package Outlines and Dimensions

### TITLE

8 LEAD TDFN 2.0x2.0mm COL PACKAGE OUTLINE & RECOMMENDED LAND PATTERN

<b>DRAWING #</b>	CTDFN22-8LD-PL-1	<b>UNIT</b>	MM
<b>Lead Frame</b>	NiPdAu	<b>Lead Finish</b>	NiPdAu

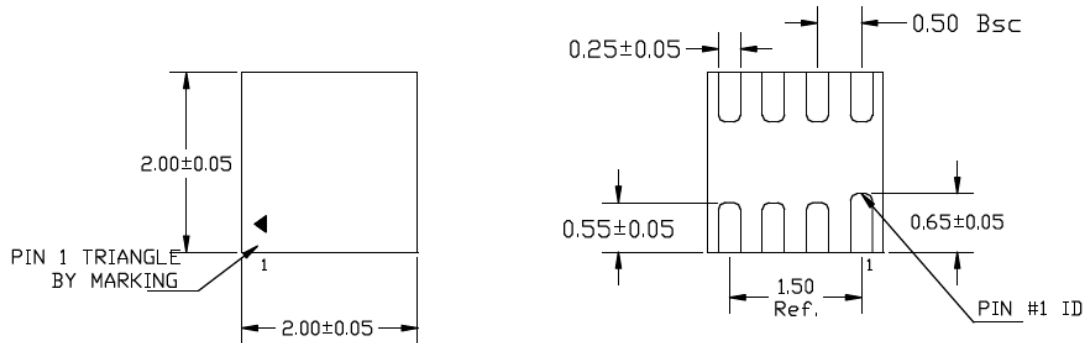

TOP VIEW

NOTE: 1, 2, 3

BOTTOM VIEW

NOTE: 1, 2, 3

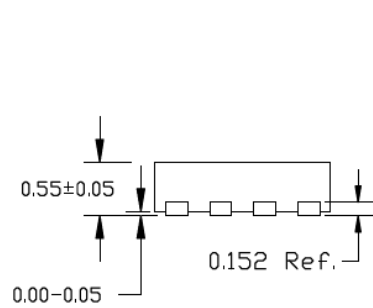

SIDE VIEW

NOTE: 1, 2, 3

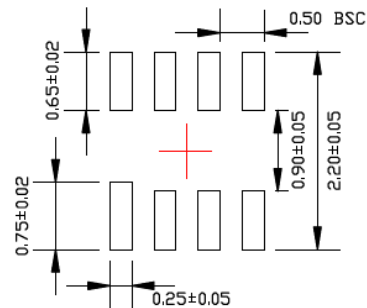

RECOMMENDED LAND PATTERN

### NOTE:

1. MAX PACKAGE WARPAGE IS 0.08 MM
2. MAX ALLOWABLE BURR IS 0.076MM IN ALL DIRECTIONS
3. PIN #1 IS ON TOP WILL BE LASER MARKED

Note: For the most current package drawings, please see the Microchip Packaging Specification located at <http://www.microchip.com/packaging>.

## Package Outlines and Dimensions

**TITLE**

10 LEAD TDFN 2.0x2.0mm COL PACKAGE OUTLINE & RECOMMENDED LAND PATTERN

<b>DRAWING #</b>	CTDFN22-10LD-PL-1	<b>UNIT</b>	MM
<b>Lead Frame</b>	NiPdAu	<b>Lead Finish</b>	NiPdAu

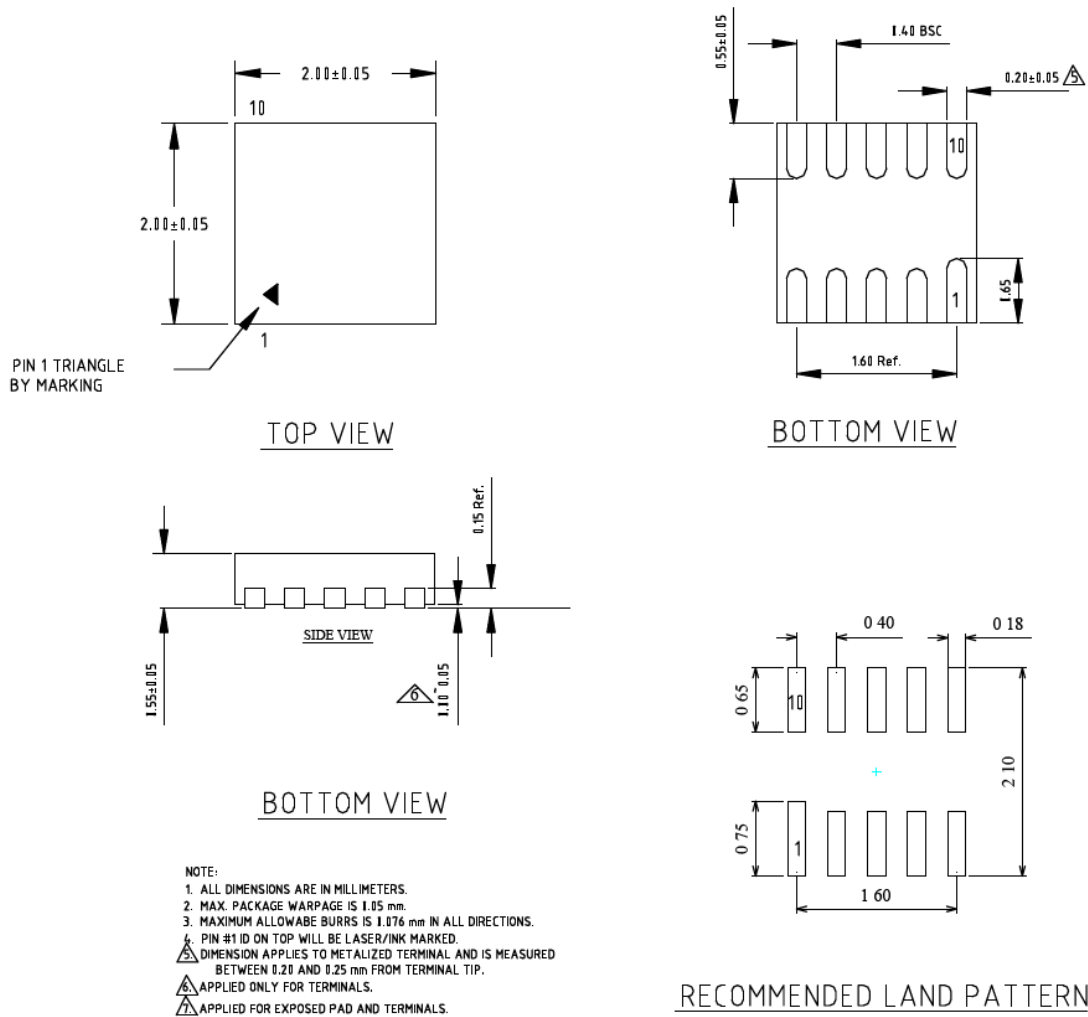

Note: For the most current package drawings, please see the Microchip Packaging Specification located at <http://www.microchip.com/packaging>.



**MICROCHIP**

---

---

**Package Outlines and Dimensions**

---

---

NOTES:

---

---

**Package Outlines and Dimensions**

---

---

**CTQFN**

Micrel Legacy

## Package Outlines and Dimensions

### TITLE

20LD COL TQFN 3.0x3.0mm PACKAGE OUTLINE & RECOMMENDED LAND PATTERN

<b>DRAWING #</b>	CTQFN33-20LD-PL-1	<b>UNIT</b>	mm
<b>Lead Frame</b>	Copper	<b>Lead Finish</b>	Matte Tin

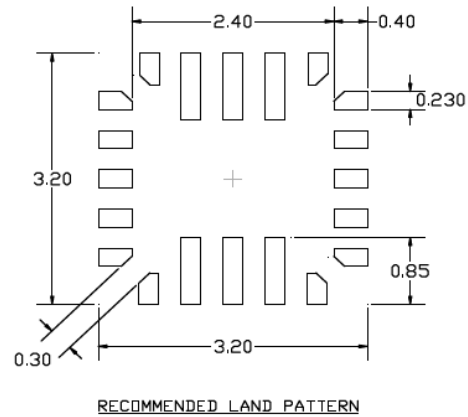
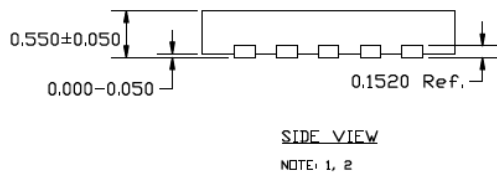
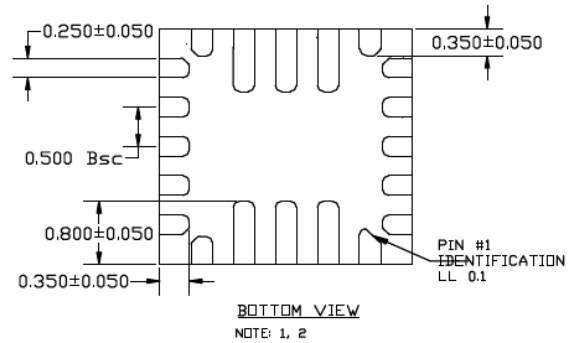
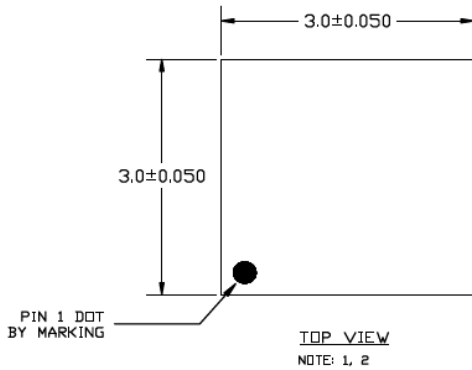

NOTE:  
1. MAX PACKAGE WARPAGE IS 0.05 MM  
2. MAX ALLOWABLE BURR IS 0.076MM IN ALL DIRECTIONS

Note: For the most current package drawings, please see the Microchip Packaging Specification located at <http://www.microchip.com/packaging>.

---

---

**Package Outlines and Dimensions**

---

---

**DFN**

Micrel Legacy

**Package Outlines and Dimensions**

**TITLE**

4 LEAD DFN 7.0x5.0mm PACKAGE OUTLINE & RECOMMENDED LAND PATTERN

<b>DRAWING #</b>	DFN75-4LD-PL-1	<b>UNIT</b>	MM
------------------	----------------	-------------	----

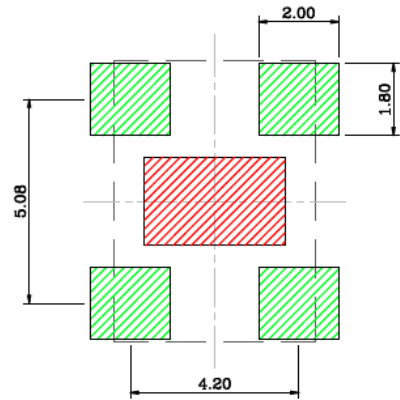
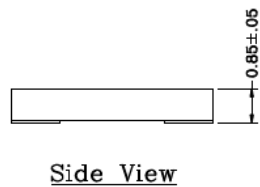
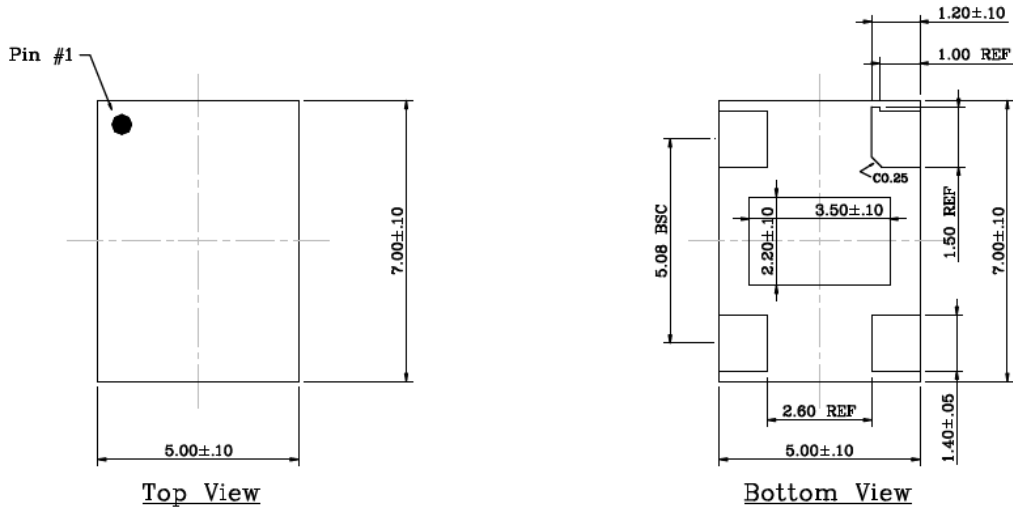

**Recommended Land Pattern**

**NOTE:**

1. Green shaded rectangles in Recommended Land Pattern are solder stencil opening.
2. Red shaded rectangle in Recommended Land Pattern is keep out area.

Note: For the most current package drawings, please see the Microchip Packaging Specification located at <http://www.microchip.com/packaging>.



## Package Outlines and Dimensions

**TITLE**

4 LEAD DFN 1.2 x 1.6 mm PACKAGE OUTLINE & RECOMMENDED LAND PATTERN

<b>DRAWING #</b>	DFN1216-4LD-PL-1	<b>UNIT</b>	MM
------------------	------------------	-------------	----

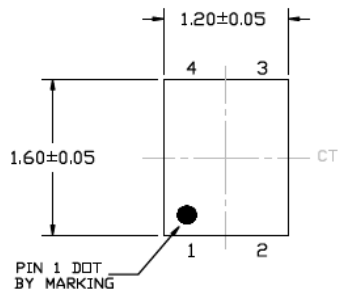

TOP VIEW  
NOTE: 1, 2, 3

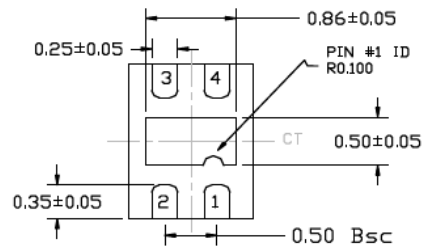

BOTTOM VIEW  
NOTE: 1, 2, 3

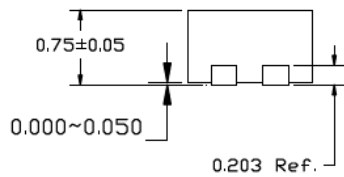

SIDE VIEW  
NOTE: 1, 2, 3

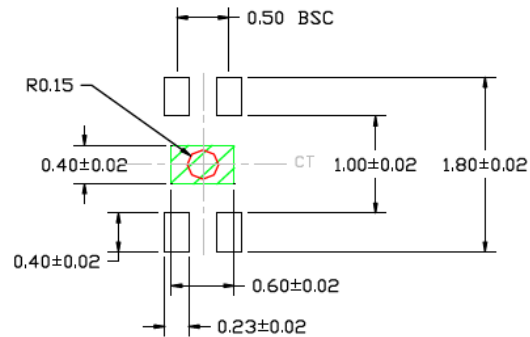

RECOMMENDED LAND PATTERN  
NOTE: 4, 5

**NOTE:**

1. MAX PACKAGE WARPAGE IS 0.05mm.
2. MAX ALLOWABLE BURR IS 0.076mm IN ALL DIRECTIONS.
3. PIN #1 IS ON TOP WILL BE LASER MARKED
4. RED CIRCLE IN LAND PATTERN REPRESENTS THERMAL VIA. SIZE SHOULD BE 0.30-0.35mm IN DIAMETER AND SHOULD BE CONNECTED TO GND FOR MAX THERMAL PERFORMANCE
5. GREEN RECTANGLE (SHADED AREA) REPRESENTS SOLDER STENCIL OPENING ON EXPOSED PAD AREA. RECOMMENDED SIZE IS 0.60mmx0.40mm.

Note: For the most current package drawings, please see the Microchip Packaging Specification located at <http://www.microchip.com/packaging>.

**Package Outlines and Dimensions**

**TITLE**

4 LEAD DFN 1.2 x 1.6 mm PACKAGE OUTLINE & RECOMMENDED LAND PATTERN

DRAWING #	DFN1216-4LD-PL-1	UNIT	MM
-----------	------------------	------	----

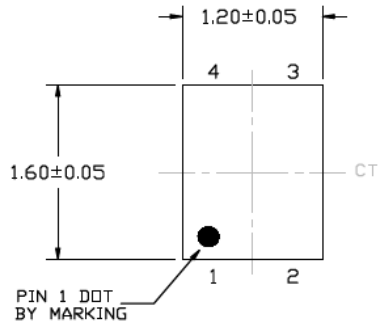

TOP VIEW  
NOTE: 1, 2, 3

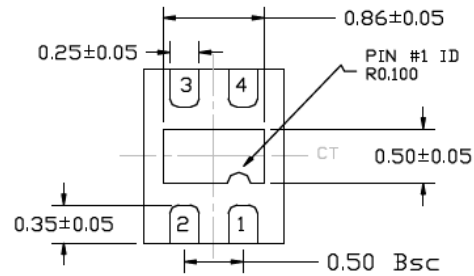

BOTTOM VIEW  
NOTE: 1, 2, 3

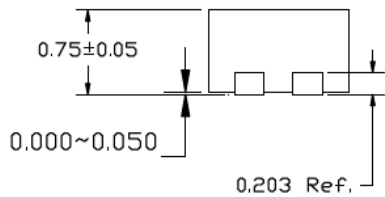

SIDE VIEW  
NOTE: 1, 2, 3

**NOTE:**

1. MAX PACKAGE WARPAGE IS 0.05mm.
2. MAX ALLOWABLE BURR IS 0.076mm IN ALL DIRECTIONS.
3. PIN #1 IS ON TOP WILL BE LASER MARKED
4. RED CIRCLE IN LAND PATTERN REPRESENTS THERMAL VIA. SIZE SHOULD BE 0.30-0.35mm IN DIAMETER AND SHOULD BE CONNECTED TO GND FOR MAX THERMAL PERFORMANCE
5. GREEN RECTANGLE (SHADED AREA) REPRESENTS SOLDER STENCIL OPENING ON EXPOSED PAD AREA. RECOMMENDED SIZE IS 0.60mmx0.40mm.

Note: For the most current package drawings, please see the Microchip Packaging Specification located at <http://www.microchip.com/packaging>.

**Package Outlines and Dimensions**

POD-Land Pattern drawing #DFN1216-4LD-PL-1

RECOMMENDED LAND PATTERN

NOTE: 4, 5

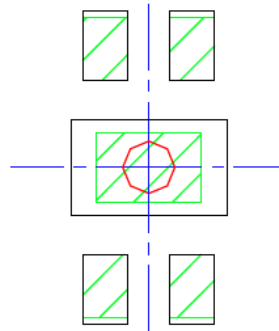

STACKED-UP

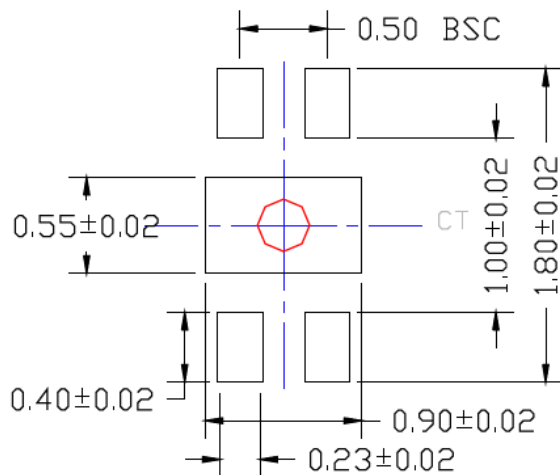

EXPOSED METAL TRACE

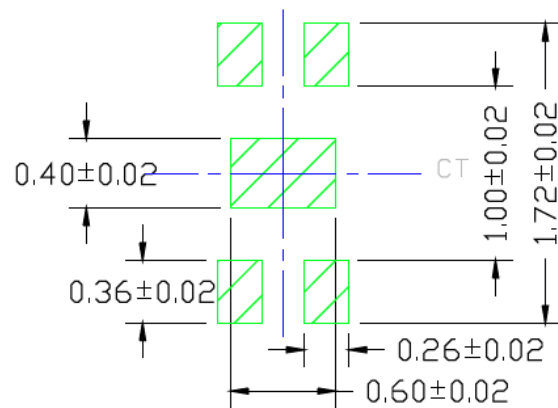

SOLDER STENCIL OPENING

Note: For the most current package drawings, please see the Microchip Packaging Specification located at <http://www.microchip.com/packaging>.

**Package Outlines and Dimensions**

**TITLE**

6 LEAD DFN 2x2mm PACKAGE OUTLINE & RECOMMENDED LAND PATTERN

<b>DRAWING #</b>	DFN22-6LD-PL-1	<b>UNIT</b>	MM
------------------	----------------	-------------	----

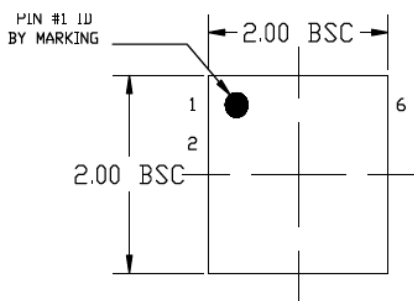

TOP VIEW

NOTE: 1, 2, 3

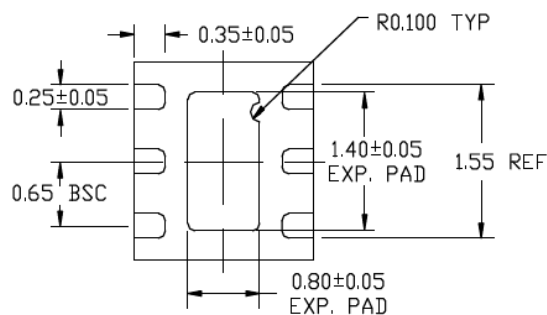

BOTTOM VIEW

NOTE: 1, 2, 3

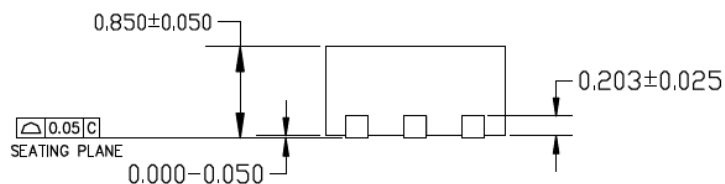

END VIEW

NOTE: 1, 2, 3

**NOTE:**

1. MAX PACKAGE WARPAGE IS 0.05 MM
2. MAX ALLOWABLE BURR IS 0.076MM IN ALL DIRECTIONS
3. PIN #1 IS ON TOP WILL BE LASER MARKED
4. RED CIRCLE IN LAND PATTERN INDICATE THERMAL VIA. SIZE SHOULD BE 0.30-0.3MM IN DIAMETER AND SHOULD BE CONNECTED TO GND FOR MAX THERMAL PERFORMANCE
5. GREEN RECTANGLES (SHADED AREA) INDICATE SOLDER STENCIL OPENING ON EXPOSED PAD AREA. SIZE SHOULD BE 0.60x0.40 MM IN SIZE, 0.20 MM SPACING.

Note: For the most current package drawings, please see the Microchip Packaging Specification located at <http://www.microchip.com/packaging>.

---



---

## Package Outlines and Dimensions

---



---

**TITLE**

6 LEAD DFN 1.6x1.6mm PACKAGE OUTLINE &amp; RECOMMENDED LAND PATTERN

<b>DRAWING #</b>	DFN1616-6LD-PL-1	<b>UNIT</b>	MM
------------------	------------------	-------------	----

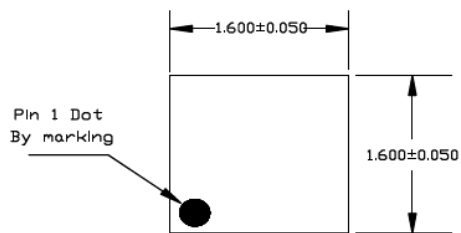

TOP VIEW

NOTE: 1, 2, 3

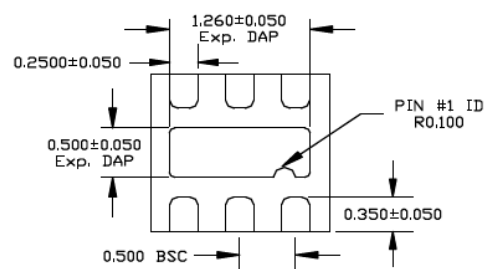

BOTTOM VIEW

NOTE: 1, 2, 3

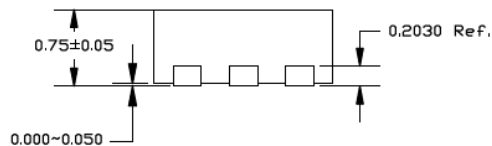

END VIEW

NOTE: 1, 2, 3

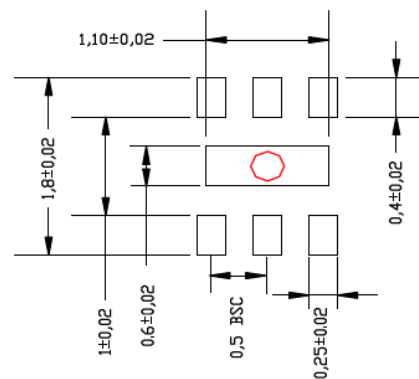

RECOMMENDED LAND PATTERN

NOTE: 4

**NOTE:**

1. MAX PACKAGE WARPAGE IS 0.05 MM
2. MAX ALLOWABLE BURR IS 0.076MM IN ALL DIRECTIONS
3. PIN #1 IS ON TOP WILL BE LASER MARKED
4. RED CIRCLE IN LAND PATTERN INDICATE THERMAL VIA. SIZE SHOULD BE 0.30-0.3MM IN DIAMETER AND SHOULD BE CONNECTED TO GND FOR MAX THERMAL PERFORMANCE

Note: For the most current package drawings, please see the Microchip Packaging Specification located at <http://www.microchip.com/packaging>.

**Package Outlines and Dimensions**

**TITLE**

6 LEAD DFN 1.6x1.6mm PACKAGE OUTLINE & RECOMMENDED LAND PATTERN

<b>DRAWING #</b>	DFN1616-6LD-PL-1	<b>UNIT</b>	MM
------------------	------------------	-------------	----

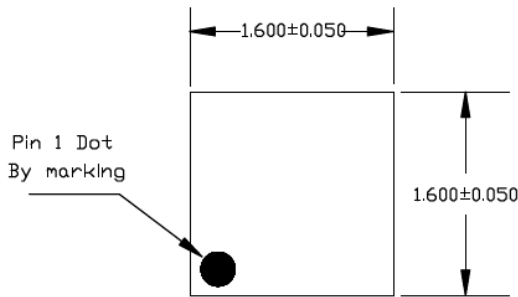

TOP VIEW

NOTE: 1, 2, 3

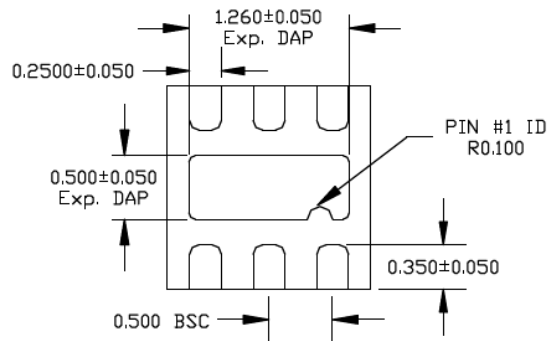

BOTTOM VIEW

NOTE: 1, 2, 3

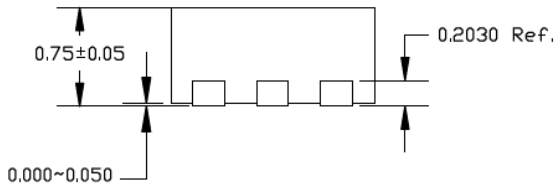

END VIEW

NOTE: 1, 2, 3

**NOTE:**

1. MAX PACKAGE WARPAGE IS 0.05 MM
2. MAX ALLOWABLE BURR IS 0.076 MM IN ALL DIRECTIONS
3. PIN #1 IS ON TOP WILL BE LASER MARKED
4. RED CIRCLE IN LAND PATTERN INDICATE THERMAL VIA. SIZE SHOULD BE 0.30-0.35 MM IN DIAMETER AND SHOULD BE CONNECTED TO GND FOR MAX THERMAL PERFORMANCE

Note: For the most current package drawings, please see the Microchip Packaging Specification located at <http://www.microchip.com/packaging>.

**Package Outlines and Dimensions**

POD-Land Pattern drawing #DFN1616-6LD-PL-1

RECOMMENDED LAND PATTERN

NOTE: 4

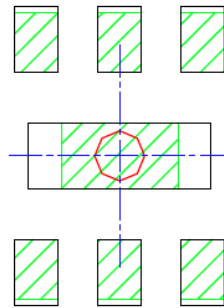

STACKED-UP

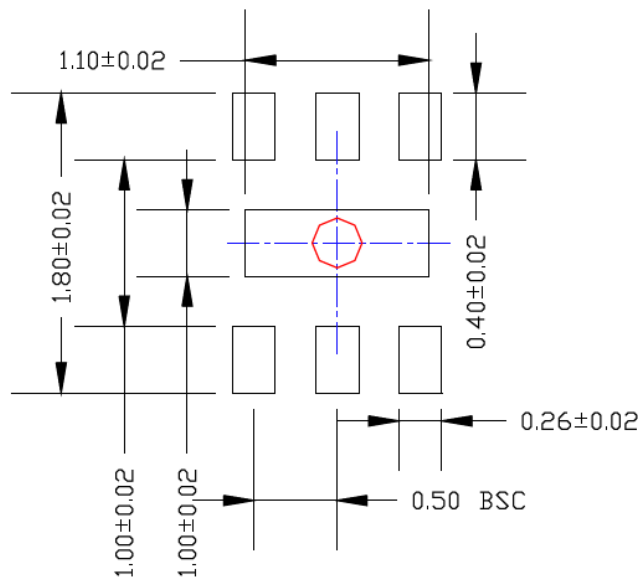

EXPOSED METAL TRACE

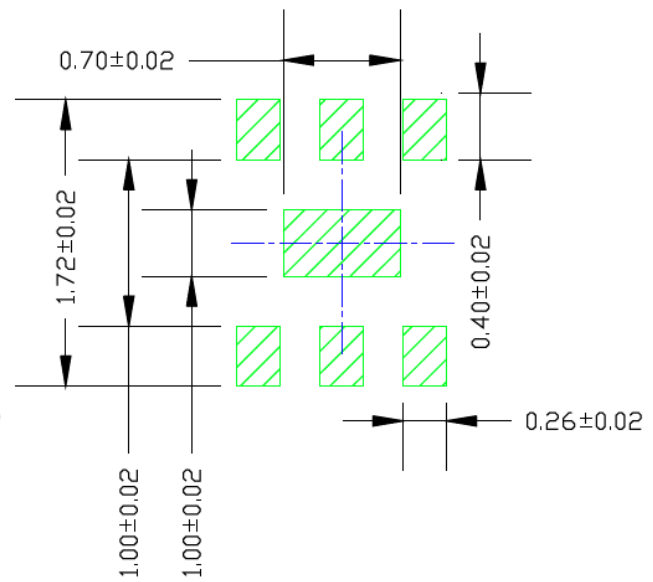

SOLDER STENCIL OPENING

## Package Outlines and Dimensions

### TITLE

8 LEAD DFN 2x2mm PACKAGE OUTLINE & RECOMMENDED LAND PATTERN

DRAWING #	DFN22-8LD-PL-1	UNIT	MM
-----------	----------------	------	----

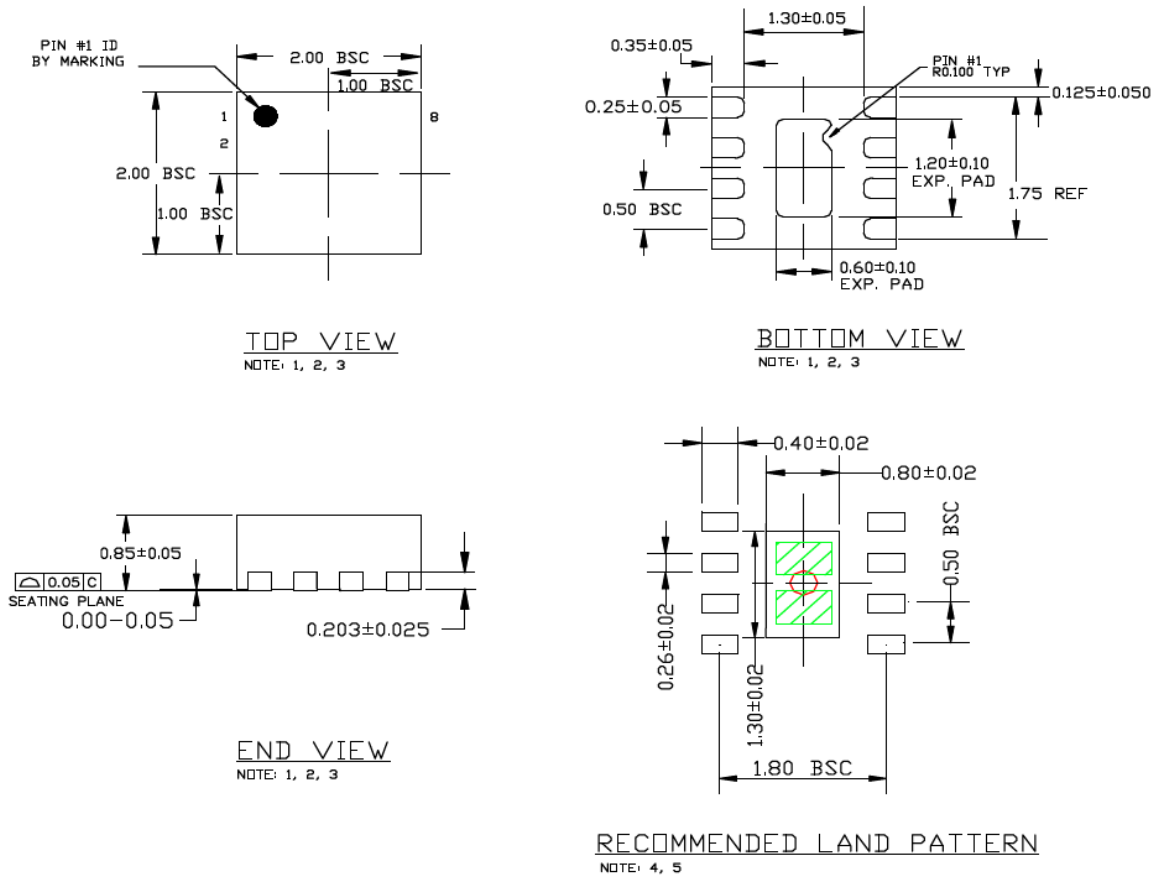

#### NOTE:

1. MAX PACKAGE WARPAGE IS 0.05 MM
2. MAX ALLOWABLE BURR IS 0.076MM IN ALL DIRECTIONS
3. PIN #1 IS ON TOP WILL BE LASER MARKED
4. RED CIRCLE IN LAND PATTERN INDICATE THERMAL VIA. SIZE SHOULD BE 0.30-0.35MM IN DIAMETER AND SHOULD BE CONNECTED TO GND FOR MAX THERMAL PERFORMANCE
5. GREEN RECTANGLES (SHADED AREA) INDICATE SOLDER STENCIL OPENING ON EXPOSED PAD AREA. SIZE SHOULD BE 0.60x0.40 MM IN SIZE, 0.20 MM SPACING.

Note: For the most current package drawings, please see the Microchip Packaging Specification located at <http://www.microchip.com/packaging>.



---



---

## Package Outlines and Dimensions

---



---

**TITLE**

8 LEAD DFN 2x2mm PACKAGE OUTLINE &amp; RECOMMENDED LAND PATTERN

DRAWING #	DFN22-8LD-PL-1	UNIT	MM
-----------	----------------	------	----

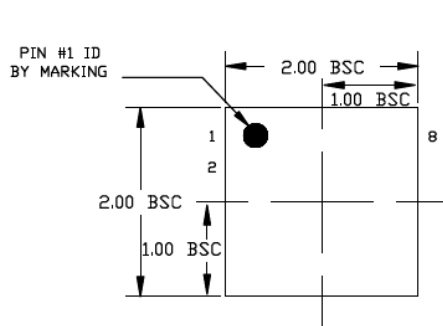

TOP VIEW  
NOTE: 1, 2, 3

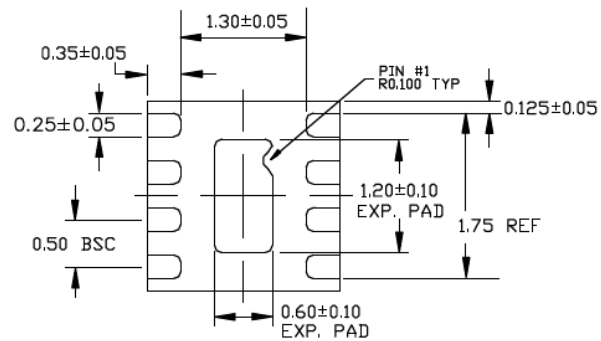

BOTTOM VIEW  
NOTE: 1, 2, 3

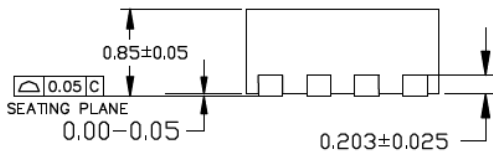

END VIEW  
NOTE: 1, 2, 3

**NOTE:**

1. MAX PACKAGE WARPAGE IS 0.05 MM
2. MAX ALLOWABLE BURR IS 0.076MM IN ALL DIRECTIONS
3. PIN #1 IS ON TOP WILL BE LASER MARKED
4. RED CIRCLE IN LAND PATTERN INDICATE THERMAL VIA. SIZE SHOULD BE 0.30-0.35MM IN DIAMETER AND SHOULD BE CONNECTED TO GND FOR MAX THERMAL PERFORMANCE
5. GREEN RECTANGLES (SHADED AREA) INDICATE SOLDER STENCIL OPENING ON EXPOSED PAD AREA. SIZE SHOULD BE 0.60x0.40 MM IN SIZE, 0.20 MM SPACING.

Note: For the most current package drawings, please see the Microchip Packaging Specification located at <http://www.microchip.com/packaging>.

**Package Outlines and Dimensions**

POD-Land Pattern Drawing # DFN22-8LD-PL-1

RECOMMENDED LAND PATTERN

NOTE: 4, 5

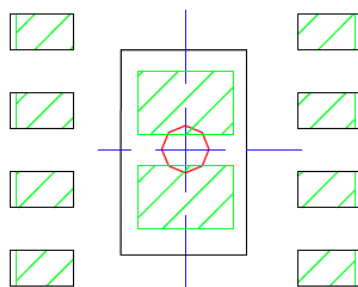

STACKED-UP

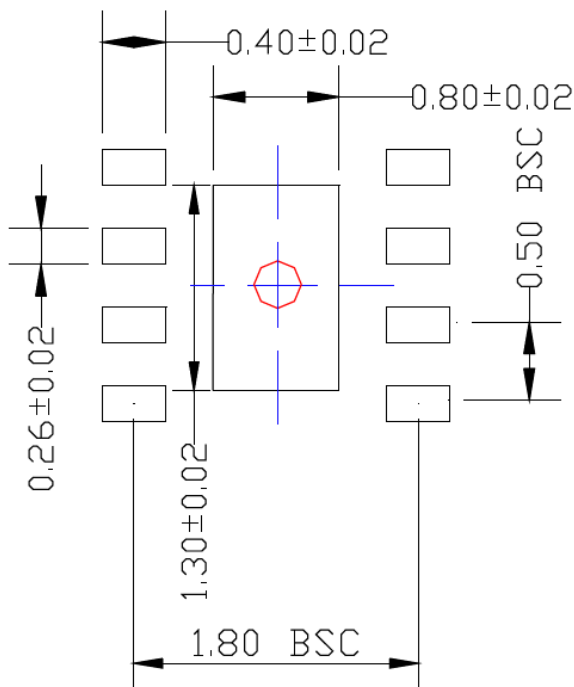

EXPOSED METAL TRACE

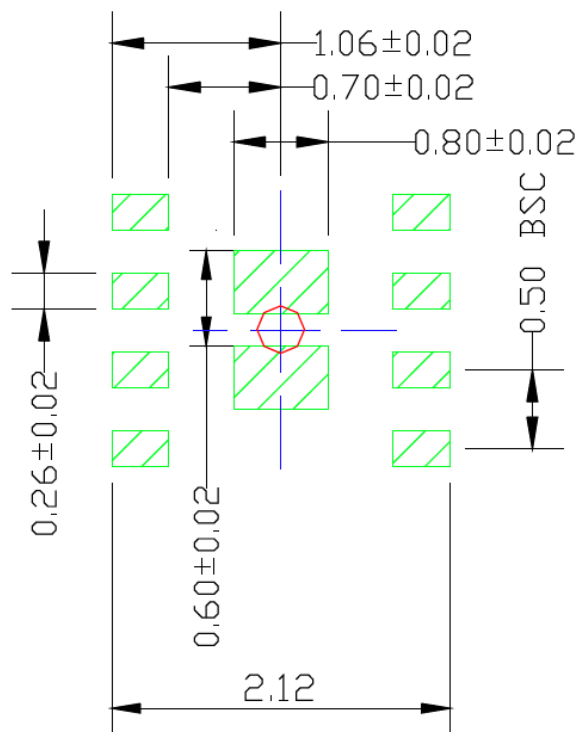

SOLDER STENCIL OPENING

Note: For the most current package drawings, please see the Microchip Packaging Specification located at <http://www.microchip.com/packaging>.

## Package Outlines and Dimensions

**TITLE**

8 LEAD DFN 2x2mm PACKAGE OUTLINE & RECOMMENDED LAND PATTERN

<b>DRAWING #</b>	DFN22-8LD-PL-8	<b>UNIT</b>	MM
------------------	----------------	-------------	----

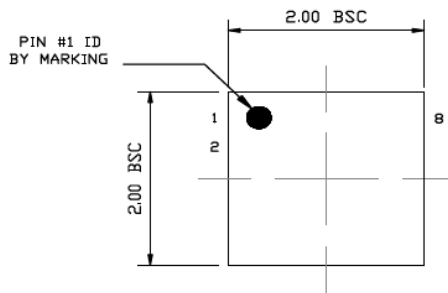

TOP VIEW

NOTE: 1, 2, 3

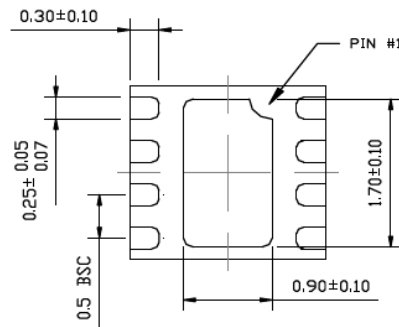

BOTTOM VIEW

NOTE: 1, 2, 3

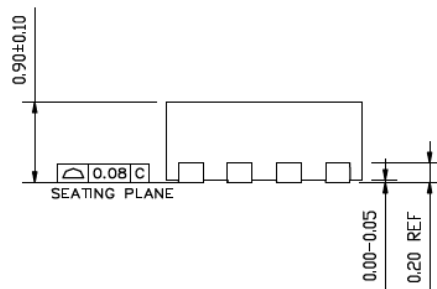

END VIEW

NOTE: 1, 2, 3

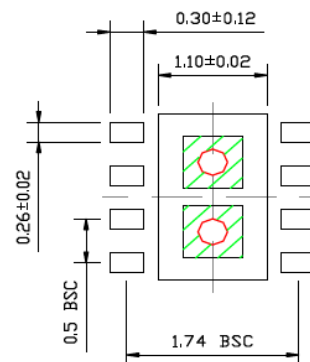

RECOMMENDED LAND PATTERN

NOTE: 4, 5

**NOTE:**

1. MAX PACKAGE WARPAGE IS 0.05mm.
2. MAX ALLOWABLE BURR IS 0.076mm IN ALL DIRECTIONS.
3. PIN #1 IS ON TOP WILL BE LASER MARKED.
4. RED CIRCLE IN LAND PATTERN INDICATES THERMAL VIA. SIZE SHOULD BE 0.30-0.35mm IN DIAMETER AND SHOULD BE CONNECTED TO GND FOR MAX THERMAL PERFORMANCE
5. GREEN RECTANGLES (SHADED AREA) INDICATE SOLDER STENCIL OPENING ON EXPOSED PAD AREA. SIZE SHOULD BE 0.60x0.60mm IN SIZE, 0.20mm SPACING.

Note: For the most current package drawings, please see the Microchip Packaging Specification located at <http://www.microchip.com/packaging>.

**Package Outlines and Dimensions**

**TITLE**

8 LEAD DFN 2x2mm PACKAGE OUTLINE & RECOMMENDED LAND PATTERN

<b>DRAWING #</b>	DFN22-8LD-PL-8	<b>UNIT</b>	MM
------------------	----------------	-------------	----

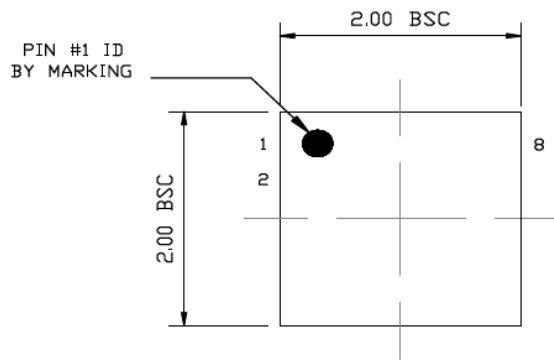

TOP VIEW  
NOTE: 1, 2, 3

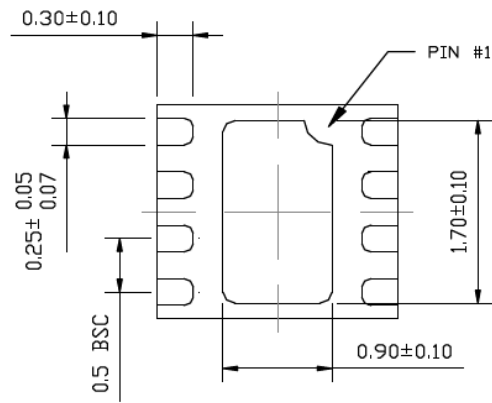

BOTTOM VIEW  
NOTE: 1, 2, 3

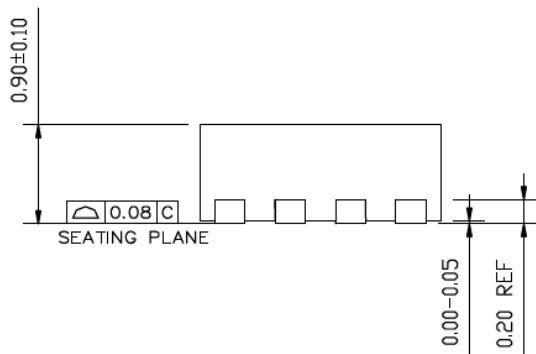

**NOTE:**

1. MAX PACKAGE WARPAGE IS 0.05mm.
2. MAX ALLOWABLE BURR IS 0.076mm IN ALL DIRECTIONS.
3. PIN #1 IS ON TOP WILL BE LASER MARKED.
4. RED CIRCLE IN LAND PATTERN INDICATES THERMAL VIA. SIZE SHOULD BE 0.30-0.35mm IN DIAMETER AND SHOULD BE CONNECTED TO GND FOR MAX THERMAL PERFORMANCE
5. GREEN RECTANGLES (SHADED AREA) INDICATE SOLDER STENCIL OPENING ON EXPOSED PAD AREA. SIZE SHOULD BE 0.60x0.60mm IN SIZE, 0.20mm SPACING.

Note: For the most current package drawings, please see the Microchip Packaging Specification located at <http://www.microchip.com/packaging>.

**Package Outlines and Dimensions**

POD-Land Pattern drawing # DFN22-8LD-PL-8

RECOMMENDED LAND PATTERN

NOTE: 4, 5

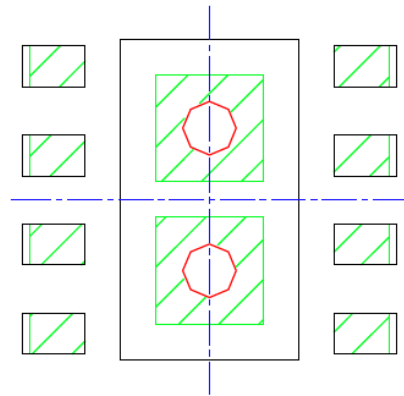

STACKED-UP

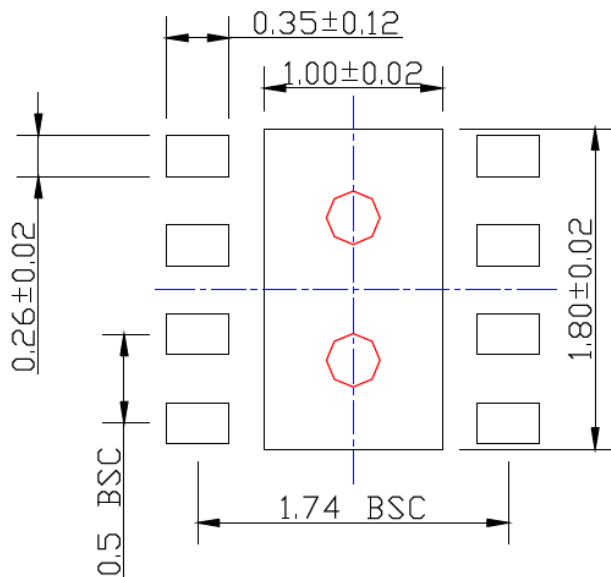

EXPOSED METAL TRACE

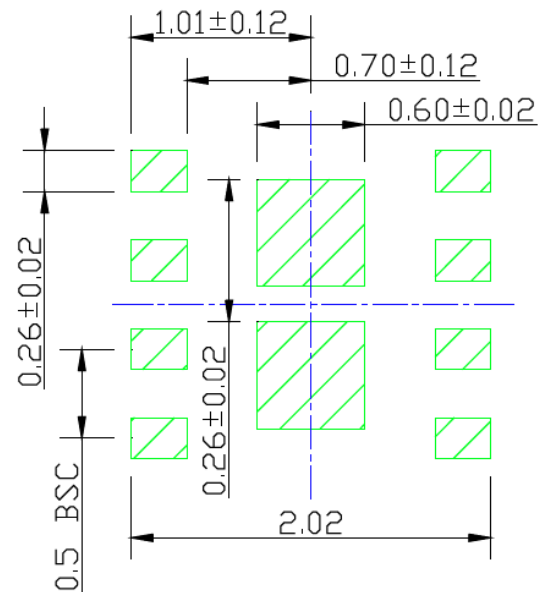

SOLDER STENCIL OPENING

Note: For the most current package drawings, please see the Microchip Packaging Specification located at <http://www.microchip.com/packaging>.

**Package Outlines and Dimensions**

**TITLE**

8 LEAD DFN 3x3mm PACKAGE OUTLINE & RECOMMENDED LAND PATTERN

<b>DRAWING #</b>	DFN33-8LD-PL-1	<b>UNIT</b>	MM
------------------	----------------	-------------	----

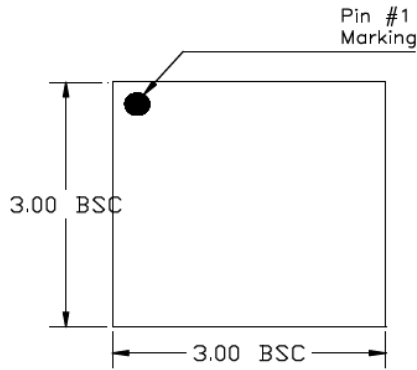

TOP VIEW  
NOTE: 1, 2, 3

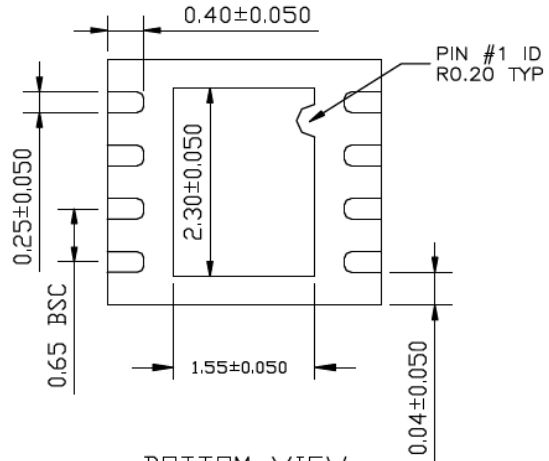

BOTTOM VIEW  
NOTE: 1, 2, 3

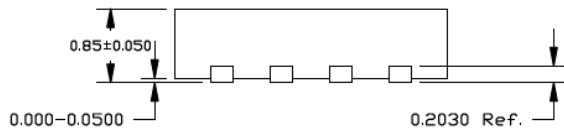

SIDE VIEW  
NOTE: 1, 2, 3

**NOTE:**

1. MAX PACKAGE WARPAGE IS 0.05 MM
2. MAX ALLOWABLE BURR IS 0.076MM IN ALL DIRECTIONS
3. PIN #1 IS ON TOP WILL BE LASER MARKED
4. RED CIRCLE IN LAND PATTERN INDICATE THERMAL VIA. SIZE SHOULD BE 0.30-0.35 MM IN DIAMETER AND SHOULD BE CONNECTED TO GND FOR MAX THERMAL PERFORMANCE
5. GREEN RECTANGLES (SHADED AREA) INDICATE SOLDER STENCIL OPENING ON EXPOSED PAD AREA. SIZE SHOULD BE 0.50x0.90 MM IN SIZE, 0.20 MM SPACING.

Note: For the most current package drawings, please see the Microchip Packaging Specification located at <http://www.microchip.com/packaging>.

**Package Outlines and Dimensions**

POD-Land Pattern drawing #DFN33-8LD-PL-1

RECOMMENDED LAND PATTERN

NOTE: 4, 5

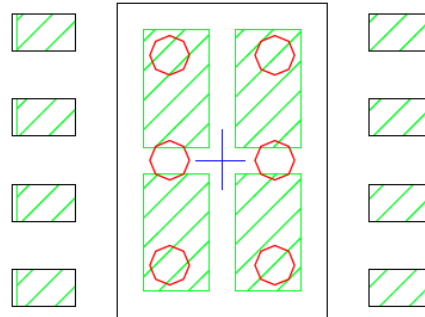

STACKED-UP

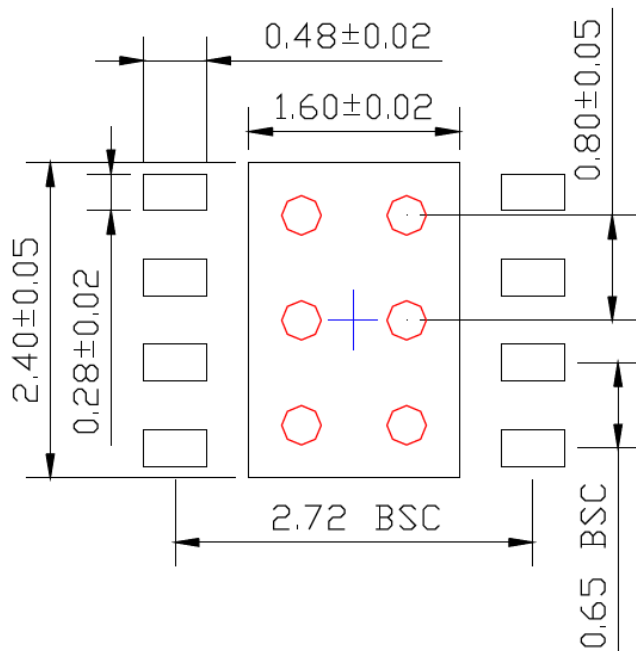

EXPOSED METAL TRACE

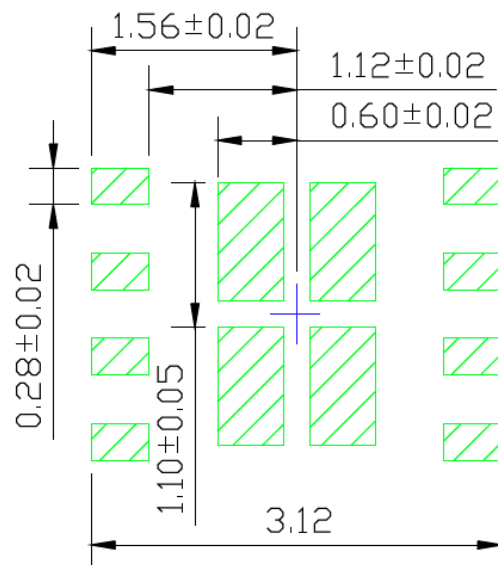

SOLDER STENCIL OPENING

Note: For the most current package drawings, please see the Microchip Packaging Specification located at <http://www.microchip.com/packaging>.

## Package Outlines and Dimensions

### TITLE

8 LEAD DFN 4.0 x 4.0 mm PACKAGE OUTLINE & RECOMMENDED LAND PATTERN

DRAWING #	DFN44-8LD-PL-1	UNIT	MM
-----------	----------------	------	----

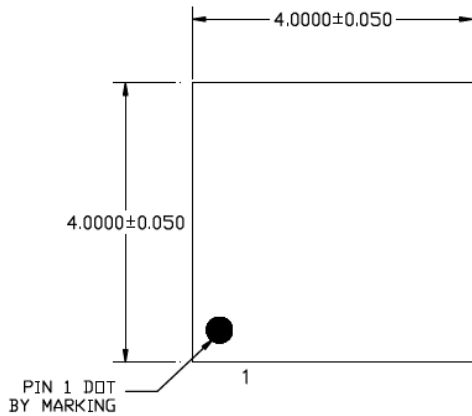

TOP VIEW

NOTE: 1, 2, 3

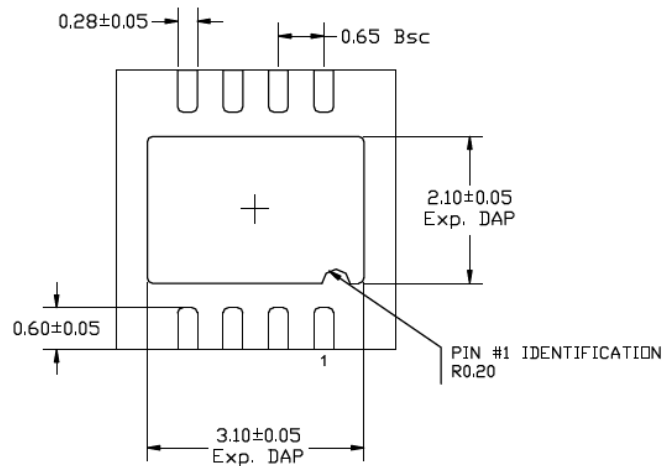

BOTTOM VIEW

NOTE: 1, 2

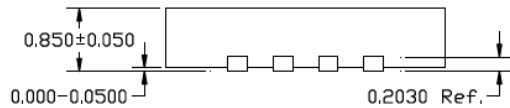

SIDE VIEW

NOTE: 1, 2

#### NOTE:

1. MAX PACKAGE WARPAGE IS 0.05MM
2. MAX ALLOWABLE BURR IS 0.076MM IN ALL DIRECTIONS
3. PIN #1 IS ON TOP WILL BE LASER MARKED
4. GREEN RECTANGLES (SHADED AREA) REPRESENT STENCIL OPENING ON EXPOSED AREA. SIZE IS 1.30X0.70 MM, 0.20 MM SPACING
5. RED CIRCLES REPRESENT THERMAL VIAS & SHOULD BE CONNECTED TO GND FOR MAX PERFORMANCE. 0.30 - 0.35 MM RECOMMENDED DIAMETER

Note: For the most current package drawings, please see the Microchip Packaging Specification located at <http://www.microchip.com/packaging>.



**Package Outlines and Dimensions**

POD-Land Pattern drawing # DFN44-8LD-PL-1

RECOMMENDED LAND PATTERN

NOTE: 4, 5

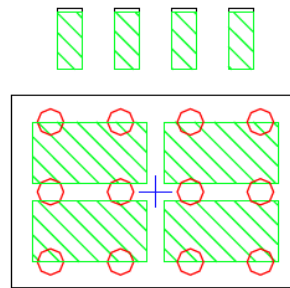

STACKED-UP

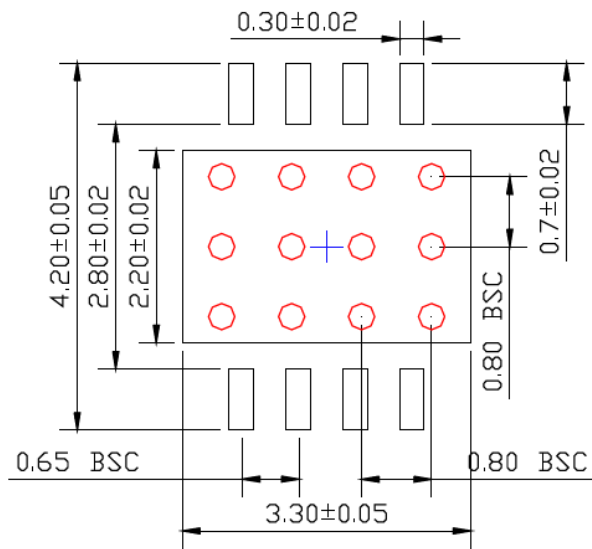

EXPOSED METAL TRACE

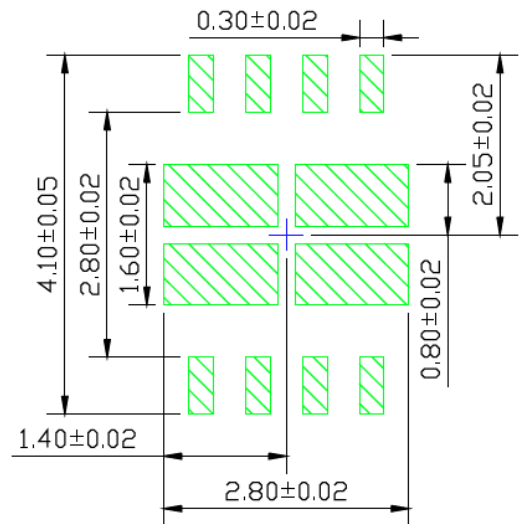

SOLDER STENCIL OPENING

Note: For the most current package drawings, please see the Microchip Packaging Specification located at <http://www.microchip.com/packaging>.

## Package Outlines and Dimensions

**TITLE**

8 LEAD DFN 4.0 x 4.0 mm PACKAGE OUTLINE & RECOMMENDED LAND PATTERN

DRAWING #	DFN44-8LD-PL-2	UNIT	MM
-----------	----------------	------	----

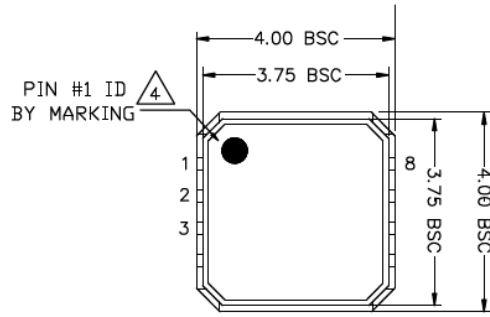

TOP VIEW

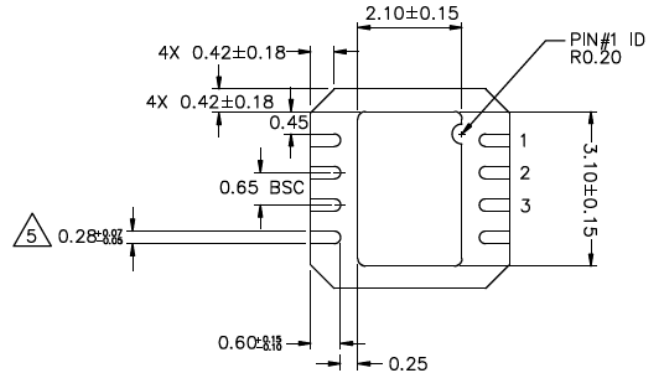

BOTTOM VIEW

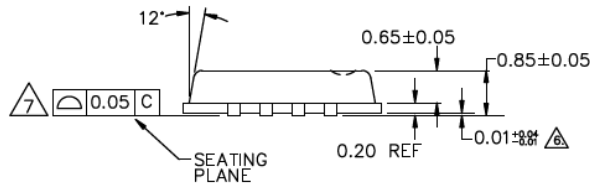

SIDE VIEW

**NOTES:**

1. ALL DIMENSIONS ARE IN MILLIMETERS.
2. MAX. PACKAGE WARPAGE IS 0.05 mm.
3. MAXIMUM ALLOWABLE BURRS IS 0.076 mm IN ALL DIRECTIONS.
4. PIN #1 ID ON TOP WILL BE LASER/INK MARKED.
5. DIMENSION APPLIES TO PLATED TERMINAL AND IS MEASURED BETWEEN 0.20 AND 0.25mm FROM TERMINAL TIP.
6. APPLIED ONLY FOR TERMINALS.
7. APPLIED FOR EXPOSED PAD AND TERMINALS.
8. GREEN RECTANGLES (SHADED AREA) REPRESENT STENCIL OPENING ON EXPOSED AREA. SIZE IS 1.30X0.70 MM, 0.20 MM SPACING
9. RED CIRCLES REPRESENT THERMAL VIAS & SHOULD BE CONNECTED TO GND FOR MAX PERFORMANCE. 0.30 - 0.35 MM RECOMMENDED DIAMETER

Note: For the most current package drawings, please see the Microchip Packaging Specification located at <http://www.microchip.com/packaging>.

**Package Outlines and Dimensions**

POD-Land Pattern drawing # DFN44-8LD-PL-2

RECOMMENDED LAND PATTERN

NOTE: 8, 9

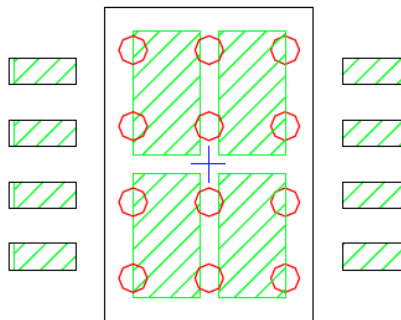

STACKED-UP

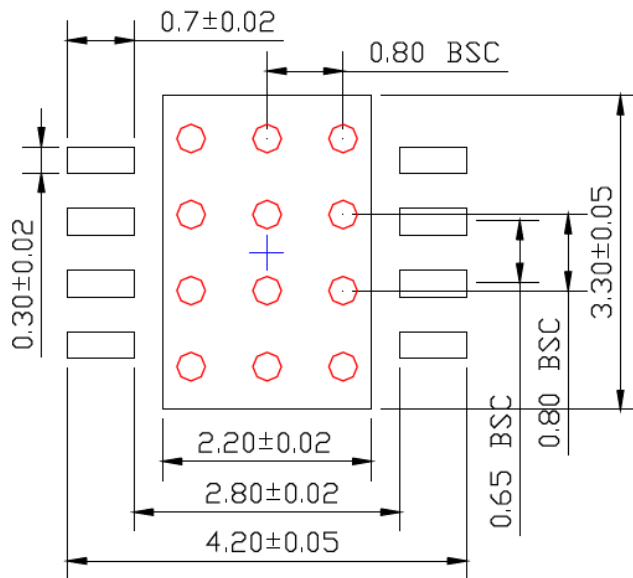

EXPOSED METAL TRACE

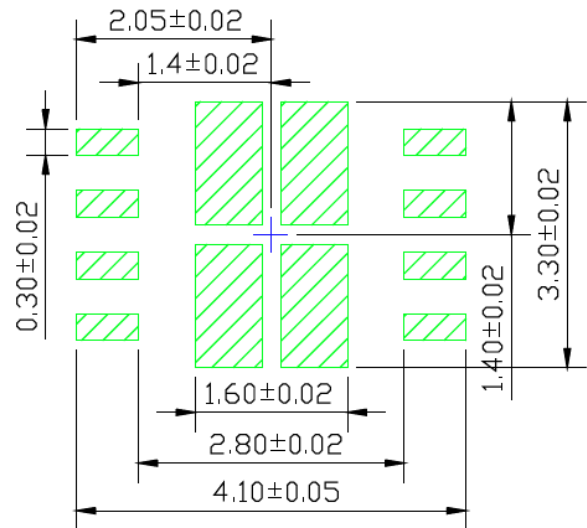

SOLDER STENCIL OPENING

Note: For the most current package drawings, please see the Microchip Packaging Specification located at <http://www.microchip.com/packaging>.

## Package Outlines and Dimensions

### TITLE

10 LEAD DFN 3x3mm PACKAGE OUTLINE & RECOMMENDED LAND PATTERN

DRAWING #	DFN33-10LD-PL-1	UNIT	MM
-----------	-----------------	------	----

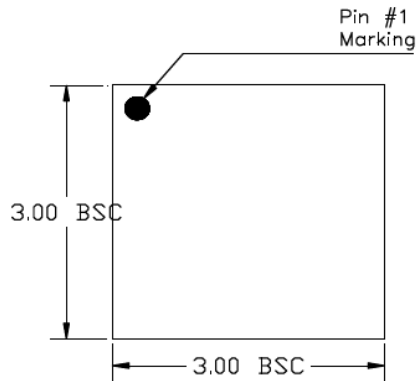

TOP VIEW

NOTE: 1, 2, 3

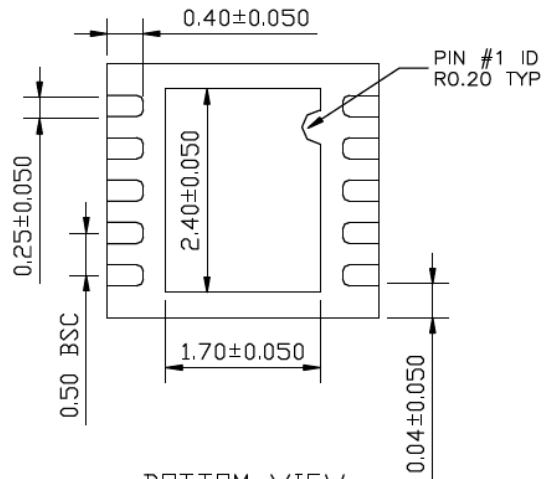

BOTTOM VIEW

NOTE: 1, 2, 3

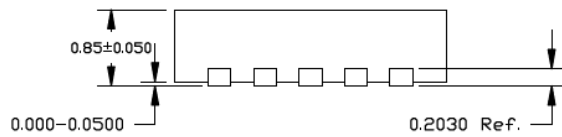

SIDE VIEW

NOTE: 1, 2, 3

### NOTE:

1. MAX PACKAGE WARPAGE IS 0.05 MM
2. MAX ALLOWABLE BURR IS 0.076MM IN ALL DIRECTIONS
3. PIN #1 IS ON TOP WILL BE LASER MARKED
4. RED CIRCLE IN LAND PATTERN INDICATE THERMAL VIA. SIZE SHOULD BE 0.30-0.35 MM IN DIAMETER AND SHOULD BE CONNECTED TO GND FOR MAX THERMAL PERFORMANCE
5. GREEN RECTANGLES (SHADED AREA) INDICATE SOLDER STENCIL OPENING ON EXPOSED PAD AREA. SIZE SHOULD BE 0.50x0.95 MM IN SIZE, 0.20 MM SPACING.

Note: For the most current package drawings, please see the Microchip Packaging Specification located at <http://www.microchip.com/packaging>.

**Package Outlines and Dimensions**

POD-Land Pattern drawing #DFN33-10LD-PL-1

RECOMMENDED LAND PATTERN

NOTE: 4, 5

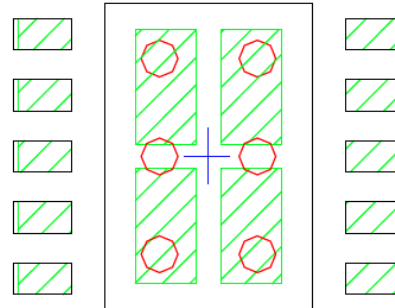

STACKED-UP

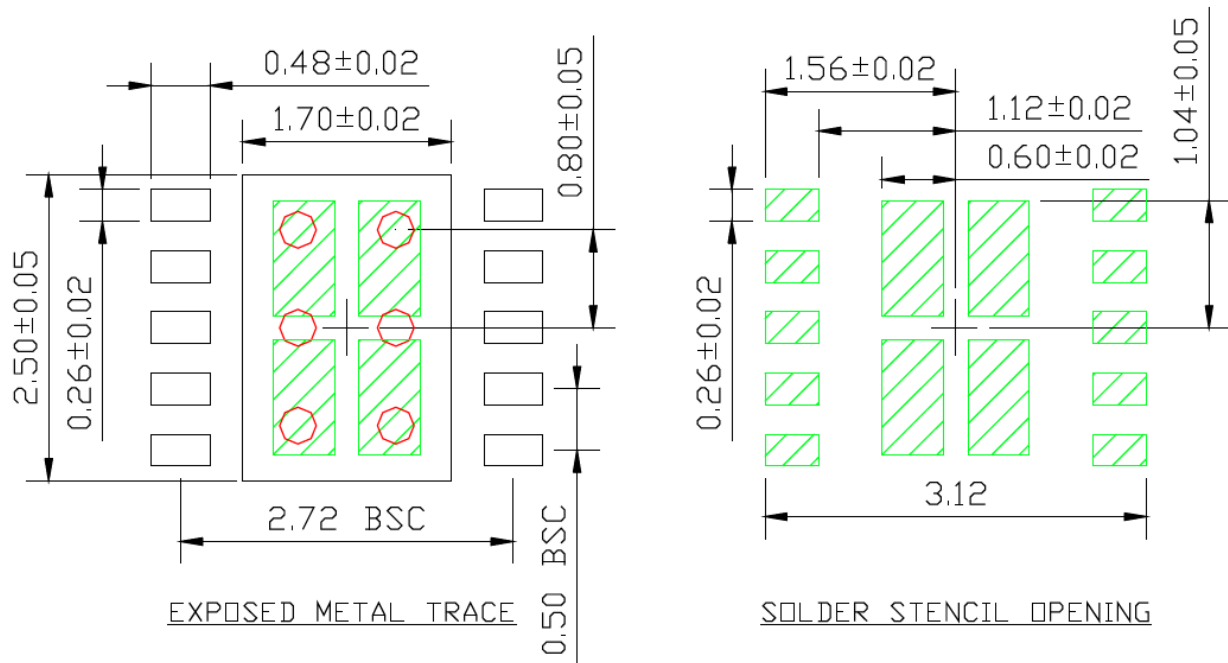

Note: For the most current package drawings, please see the Microchip Packaging Specification located at <http://www.microchip.com/packaging>.

## Package Outlines and Dimensions

### TITLE

10 LEAD DFN 2.5 x 2.5 mm PACKAGE OUTLINE & RECOMMENDED LAND PATTERN

DRAWING #	DFN2525-10LD-PL-1	UNIT	MM
-----------	-------------------	------	----

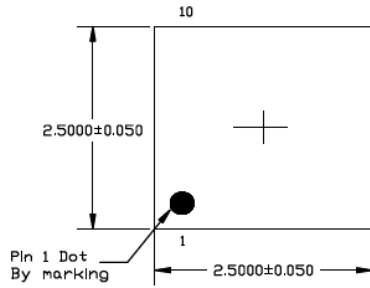

TOP VIEW  
NOTE: 1, 2, 3

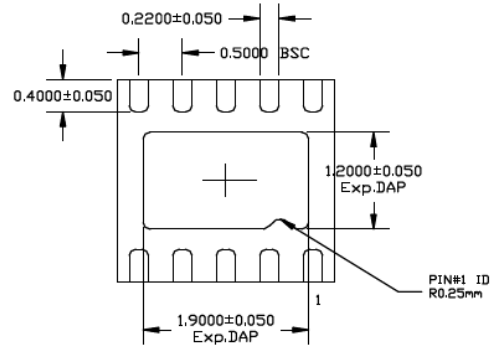

BOTTOM VIEW  
NOTE: 1, 2, 3

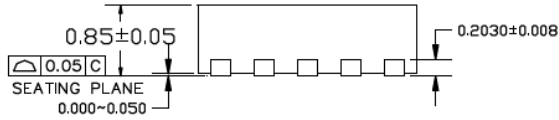

SIDE VIEW  
NOTE: 1, 2, 3

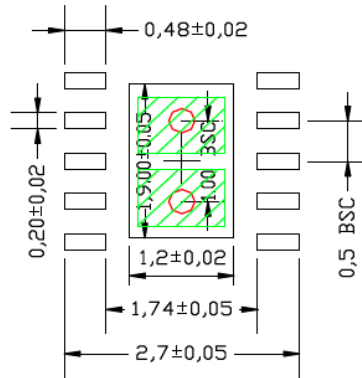

RECOMMENDED LAND PATTERN  
NOTE: 4, 5

### NOTE:

1. MAX PACKAGE WARPAGE IS 0.05 MM
2. MAX ALLOWABLE BURR IS 0.076MM IN ALL DIRECTIONS
3. PIN #1 IS ON TOP WILL BE LASER MARKED
4. RED CIRCLES IN LAND PATTERN REPRESENT THERMAL VIA. SIZE SHOULD BE 0.30-0.3MM IN DIAMETER AND SHOULD BE CONNECTED TO GND FOR MAX THERMAL PERFORMANCE
5. GREEN RECTANGLES (SHADED AREA) REPRESENT SOLDER STENCIL OPENING ON EXPOSED PAD AREA. RECOMMENDED SIZE IS 1.00x0.70 MM, 0.20 MM SPACING.

Note: For the most current package drawings, please see the Microchip Packaging Specification located at <http://www.microchip.com/packaging>.

---



---

## Package Outlines and Dimensions

---



---

**TITLE**

10 LEAD DFN 3x3 mm PACKAGE (Co-Package) OUTLINE &amp; RECOMMENDED LAND PATTERN

DRAWING #	DFN33-10LD-PL-2	UNIT	MM
Lead Frame	NiPdAu	Lead Finish	NiPdAu

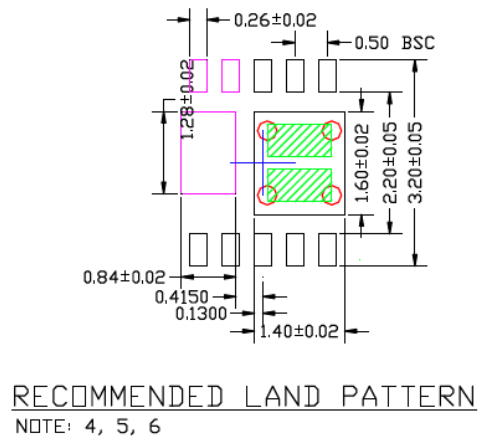
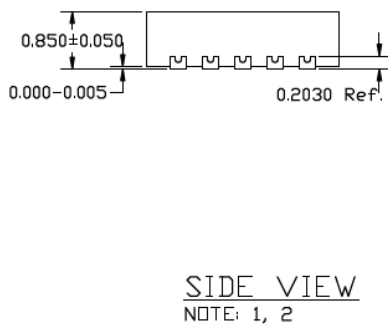
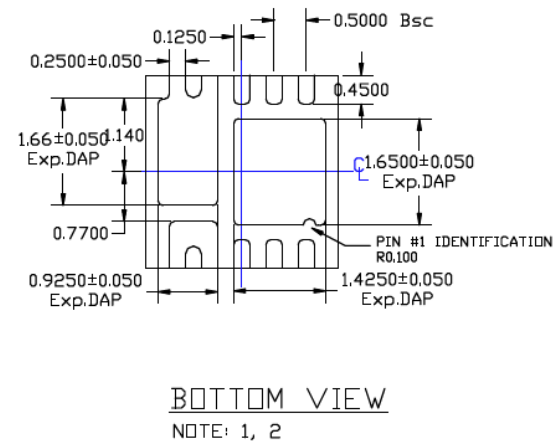
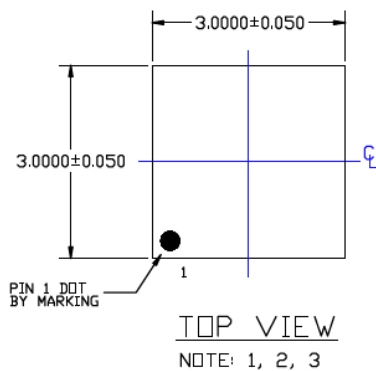
**NOTE:**

1. MAX PACKAGE WARPAGE IS 0.05MM
2. MAX ALLOWABLE BURR IS 0.076MM IN ALL DIRECTIONS
3. PIN #1 IS ON TOP WILL BE LASER MARKED
4. GREEN RECTANGLES (SHADED AREA) REPRESENT STENCIL OPENING ON EXPOSED AREA. SIZE IS 1.00X0.50 MM, 0.20 MM SPACING
5. RED CIRCLES REPRESENT THERMAL VIAS & SHOULD BE CONNECTED TO GND FOR MAX PERFORMANCE. 0.30 - 0.35 MM RECOMMENDED DIAMETER, 1.0 MM PITCH
6. PURPLE PADS ARE OF DIFFERENT POTENTIAL. DO NOT CONNECT TO GND.

Note: For the most current package drawings, please see the Microchip Packaging Specification located at <http://www.microchip.com/packaging>.

**Package Outlines and Dimensions**

**TITLE**

10 LEAD DFN 3x3 mm PACKAGE (Co-Package) OUTLINE & RECOMMENDED LAND PATTERN

<b>DRAWING #</b>	DFN33-10LD-PL-2	<b>UNIT</b>	MM
<b>Lead Frame</b>	NiPdAu	<b>Lead Finish</b>	NiPdAu

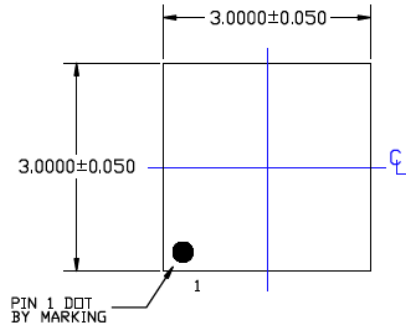

TOP VIEW

NOTE: 1, 2, 3

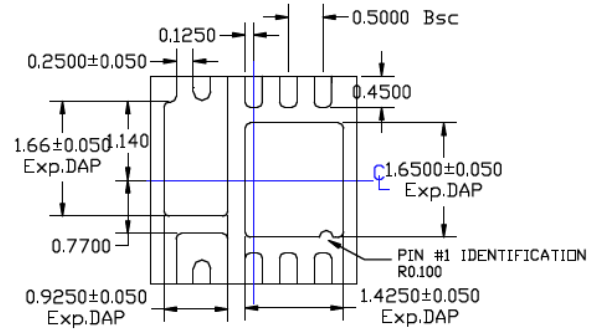

BOTTOM VIEW

NOTE: 1, 2

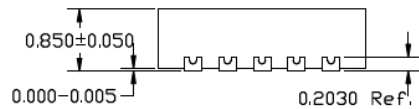

SIDE VIEW

NOTE: 1, 2

**NOTE:**

1. MAX PACKAGE WARPAGE IS 0.05MM
2. MAX ALLOWABLE BURR IS 0.076MM IN ALL DIRECTIONS
3. PIN #1 IS ON TOP WILL BE LASER MARKED
4. GREEN RECTANGLES (SHADED AREA) REPRESENT STENCIL OPENING ON EXPOSED AREA. SIZE IS 1.00X0.50 MM, 0.20 MM SPACING
5. RED CIRCLES REPRESENT THERMAL VIAS & SHOULD BE CONNECTED TO GND FOR MAX PERFORMANCE. 0.30 - 0.35 MM RECOMMENDED DIAMETER, 1.0 MM PITCH
6. PURPLE PADS ARE OF DIFFERENT POTENTIAL. DO NOT CONNECT TO GND.

Note: For the most current package drawings, please see the Microchip Packaging Specification located at <http://www.microchip.com/package>.



**Package Outlines and Dimensions**

POD-Land Pattern drawing #DFN33-10LD-PL-2

RECOMMENDED LAND PATTERN

NOTE: 4, 5, 6

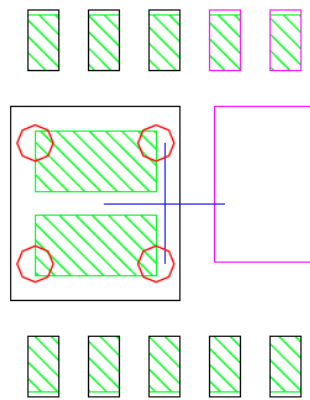

STACKED-UP

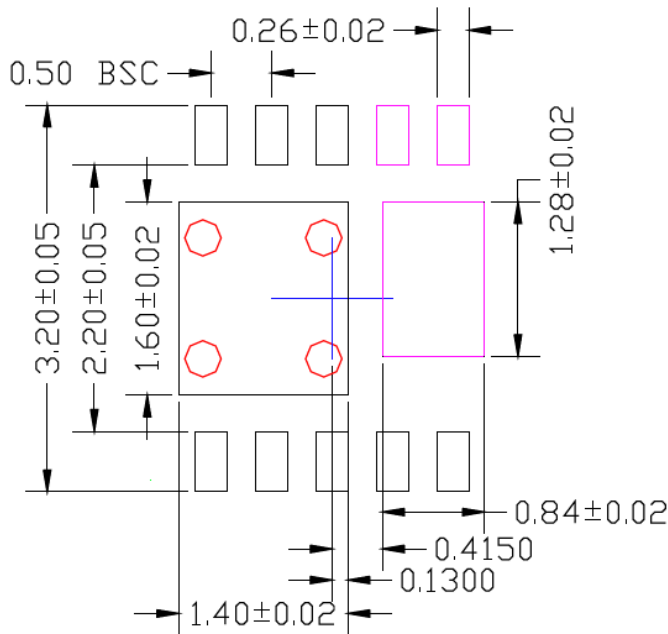

EXPOSED METAL TRACE

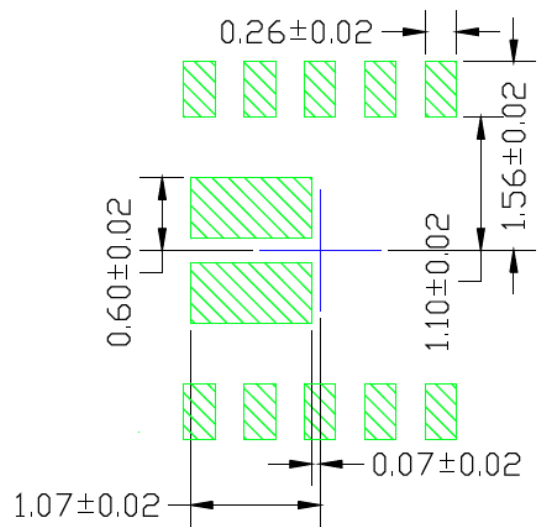

SOLDER STENCIL OPENING

Note: For the most current package drawings, please see the Microchip Packaging Specification located at <http://www.microchip.com/packaging>.

**Package Outlines and Dimensions**

**TITLE**

12 LEAD DFN 3x3mm PACKAGE OUTLINE & RECOMMENDED LAND PATTERN

<b>DRAWING #</b>	DFN33-12LD-PL-1	<b>UNIT</b>	MM
------------------	-----------------	-------------	----

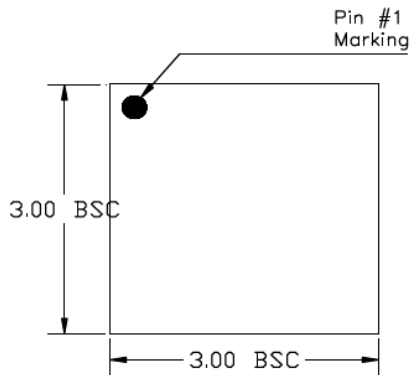

TOP VIEW  
NOTE: 1, 2, 3

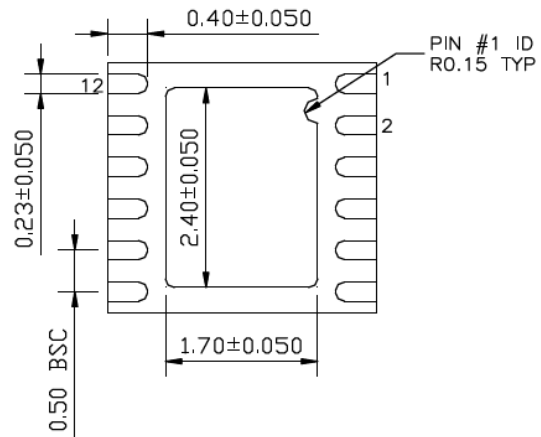

BOTTOM VIEW  
NOTE: 1, 2, 3

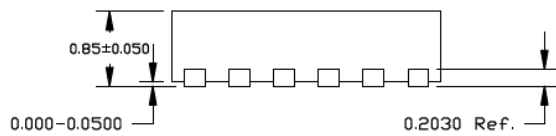

SIDE VIEW  
NOTE: 1, 2, 3

**NOTE:**

1. MAX PACKAGE WARPAGE IS 0.05 MM
2. MAX ALLOWABLE BURR IS 0.076 MM IN ALL DIRECTIONS
3. PIN #1 IS ON TOP WILL BE LASER MARKED
4. RED CIRCLE IN LAND PATTERN INDICATE THERMAL VIA. SIZE SHOULD BE 0.30-0.35 MM IN DIAMETER AND SHOULD BE CONNECTED TO GND FOR MAX THERMAL PERFORMANCE
5. GREEN RECTANGLES (SHADED AREA) INDICATE SOLDER STENCIL OPENING ON EXPOSED PAD AREA. SIZE SHOULD BE 0.50x0.95 MM IN SIZE, 0.20 MM SPACING.

Note: For the most current package drawings, please see the Microchip Packaging Specification located at <http://www.microchip.com/packaging>.

**Package Outlines and Dimensions**

POD-Land Pattern drawing # DFN33-12LD-PL-1

RECOMMENDED LAND PATTERN

NOTE: 4, 5

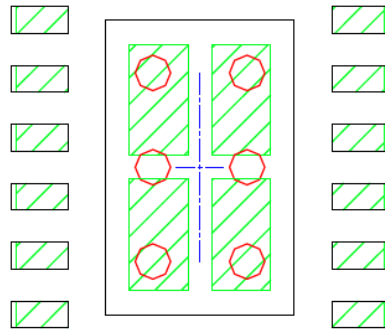

STACKED-UP

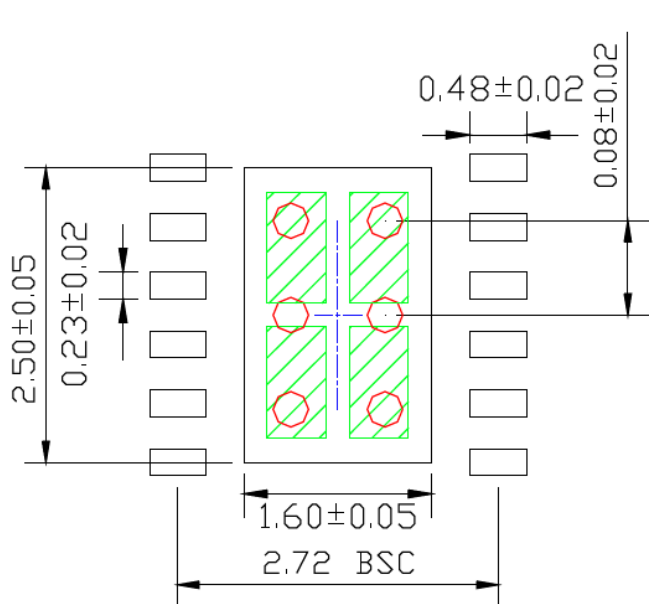

EXPOSED METAL TRACE

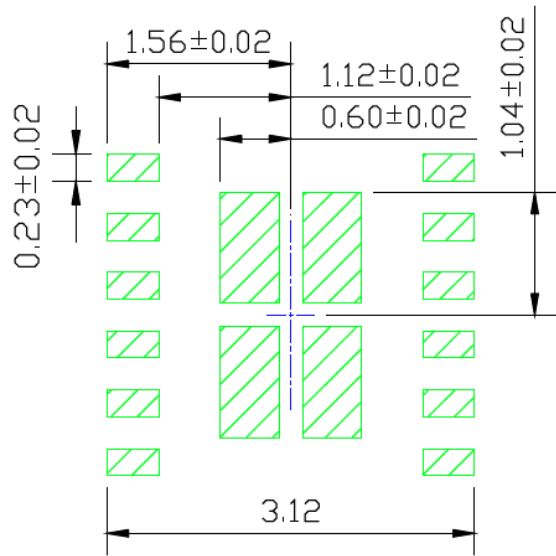

SOLDER STENCIL OPENING

Note: For the most current package drawings, please see the Microchip Packaging Specification located at <http://www.microchip.com/packaging>.

**Package Outlines and Dimensions**

**TITLE**

20 LEAD DFN 3mmx5mm PACKAGE OUTLINE & RECOMMENDED LAND PATTERN

DRAWING #	DFN35-20LD-PL-1	UNIT	MM
-----------	-----------------	------	----

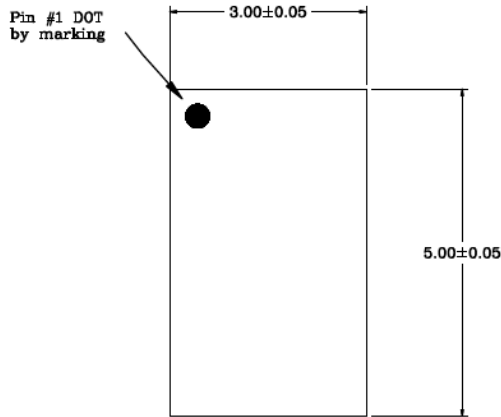

Top View  
NOTE: 1,2,3

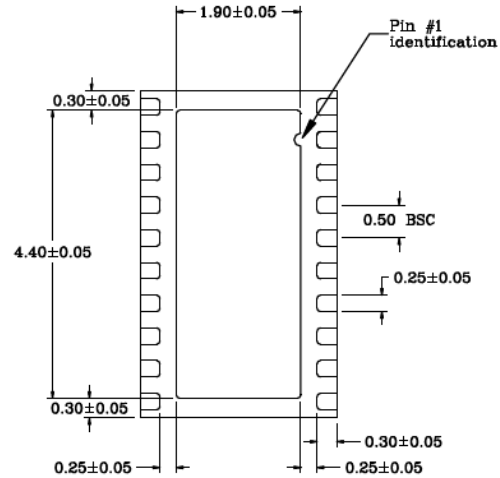

Bottom View  
NOTE: 2,3

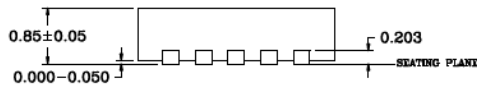

Side View  
NOTE: 2,3

**NOTES:**

1. Top mark Pin #1 will be laser mark.
2. 0.05mm max package warpage.
3. Max allowable burr is 0.076mm in all directions.
4. Red color circles are thermal via. 0.30-0.35mm in diameter and 0.80mm pitch. Should be connected to GND for maximum performance.
5. Black color pads represent different IOs. Do not connect together.
6. Shaded rectangles (area) represents solder stencil opening on exposed metal trace.
7. Recommended Land Pattern Tolerance is  $\pm 0.020$ mm unless specified.
8. See recommended Land Pattern on page2.

Note: For the most current package drawings, please see the Microchip Packaging Specification located at <http://www.microchip.com/packaging>.

## Package Outlines and Dimensions

POD-Land Pattern Doc #: DFN35-20LD-PL-1-A

### Recommended Land Pattern

Note: 4,5,6,7

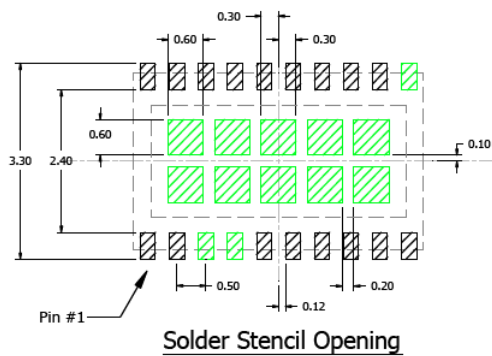
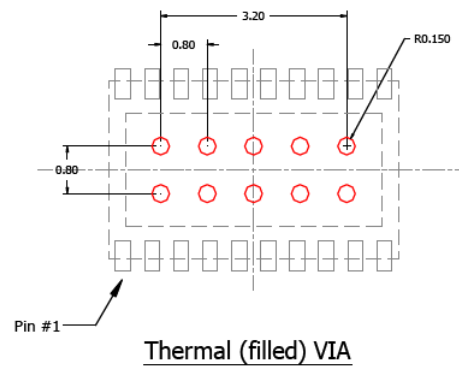
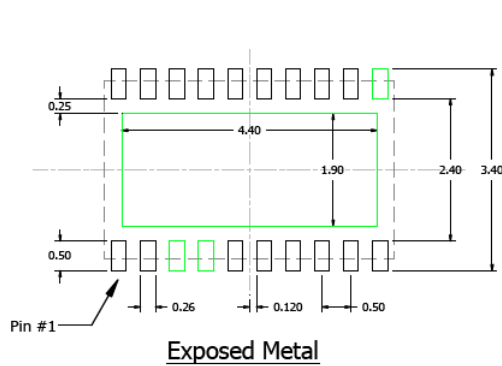
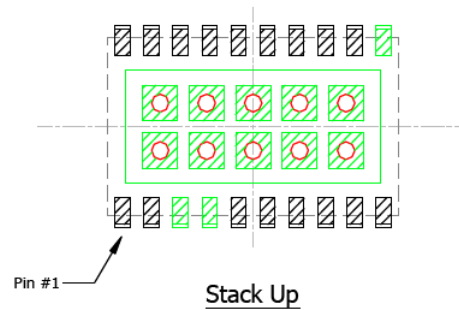

Note: For the most current package drawings, please see the Microchip Packaging Specification located at <http://www.microchip.com/packaging>.

**Package Outlines and Dimensions**

**TITLE**

12 LEAD DFN 4.0 x 4.0 mm PACKAGE OUTLINE & RECOMMENDED LAND PATTERN

<b>DRAWING #</b>	DFN44-12LD-PL-1	<b>UNIT</b>	MM
------------------	-----------------	-------------	----

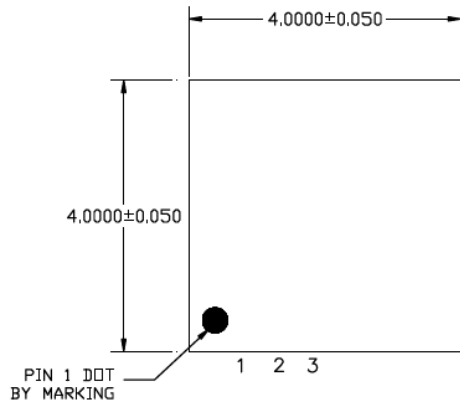

TOP VIEW

NOTE: 1, 2, 3

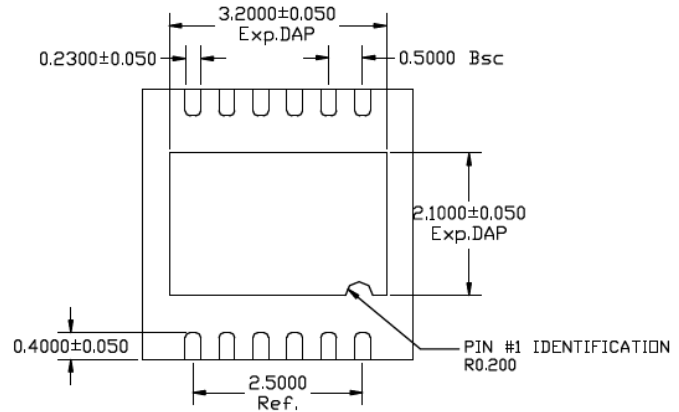

BOTTOM VIEW

NOTE: 1, 2

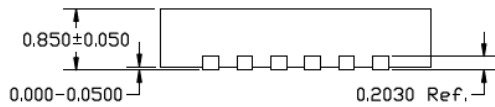

SIDE VIEW

NOTE: 1, 2

**NOTE:**

1. MAX PACKAGE WARPAGE IS 0.05MM
2. MAX ALLOWABLE BURR IS 0.076MM IN ALL DIRECTIONS
3. PIN #1 IS ON TOP WILL BE LASER MARKED
4. GREEN RECTANGLES (SHADED AREA) REPRESENT STENCIL OPENING ON EXPOSED AREA. SIZE IS 0.85X0.87 MM, 1.07 MM PITCH SPACING
5. RED CIRCLES REPRESENT THERMAL VIAS & SHOULD BE CONNECTED TO GND FOR MAX PERFORMANCE. 0.30 - 0.35 MM RECOMMENDED DIAMETER, 1.0MM PITCH SPACING

Note: For the most current package drawings, please see the Microchip Packaging Specification located at <http://www.microchip.com/packageing>.

**Package Outlines and Dimensions**

POD-Land Pattern drawing # DFN44-12LD-PL-1

RECOMMENDED LAND PATTERN

NOTE: 4, 5

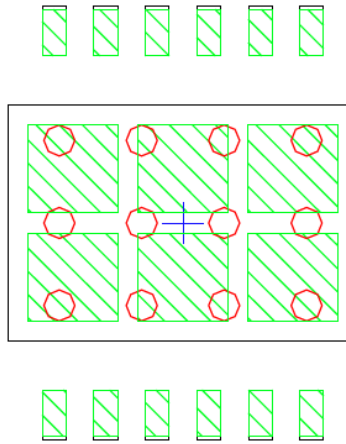

STACKED-UP

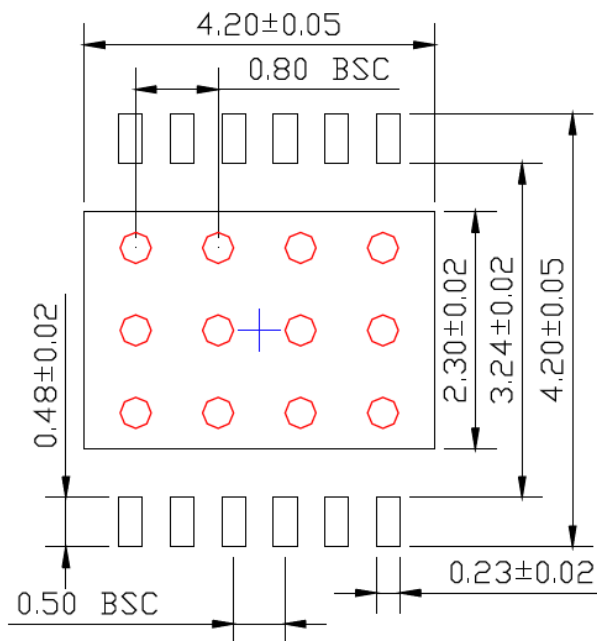

EXPOSED METAL TRACE

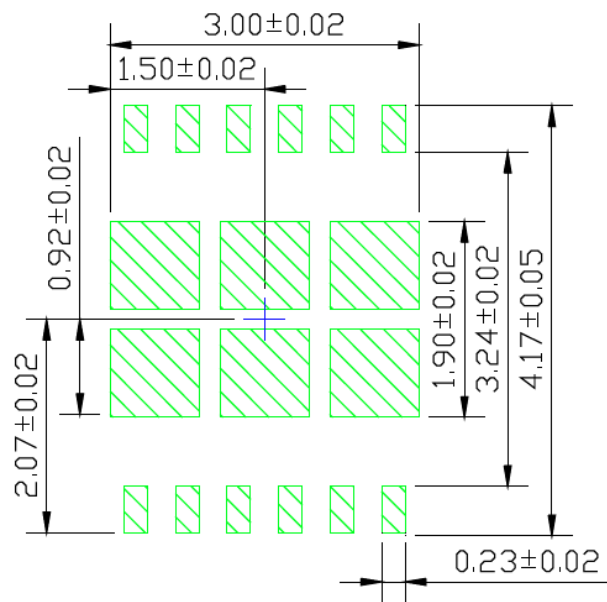

SOLDER STENCIL OPENING

Note: For the most current package drawings, please see the Microchip Packaging Specification located at <http://www.microchip.com/packaging>.

## Package Outlines and Dimensions

### TITLE

20 LEAD DFN 4.0 x 5.0 mm PACKAGE OUTLINE & RECOMMENDED LAND PATTERN

DRAWING #	DFN45-20LD-PL-1	UNIT	MM
-----------	-----------------	------	----

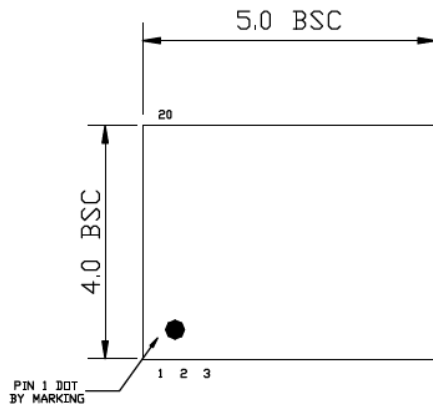

TOP VIEW  
NOTE: 1, 2, 3

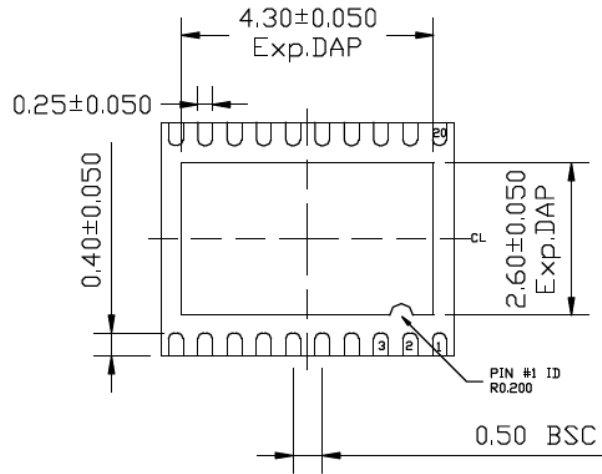

BOTTOM VIEW  
NOTE: 1, 2

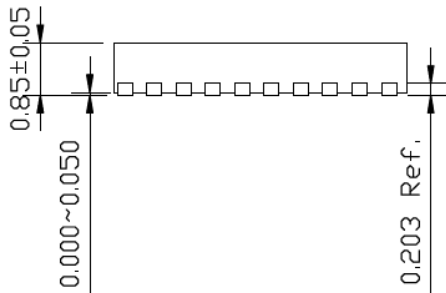

SIDE VIEW  
NOTE: 1, 2

#### NOTE:

1. MAX PACKAGE WARPAGE IS 0.05MM
2. MAX ALLOWABLE BURR IS 0.076MM IN ALL DIRECTIONS
3. PIN #1 IS ON TOP WILL BE LASER MARKED
4. GREEN RECTANGLES (SHADED AREA) REPRESENT STENCIL OPENING ON EXPOSED AREA. SIZE IS 1.17X0.60 MM, 0.80 MM SPACING
5. RED CIRCLES REPRESENT THERMAL VIAS & SHOULD BE CONNECTED TO GND FOR MAX PERFORMANCE. 0.30 - 0.35 MM RECOMMENDED DIAMETER

Note: For the most current package drawings, please see the Microchip Packaging Specification located at <http://www.microchip.com/packaging>.



**Package Outlines and Dimensions**

POD-Land Pattern drawing #DFN45-20LD-PL-1

RECOMMENDED LAND PATTERN

NOTE: 4, 5

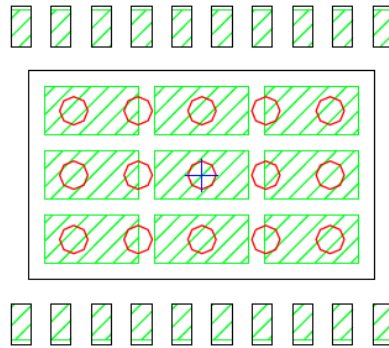

STACKED-UP

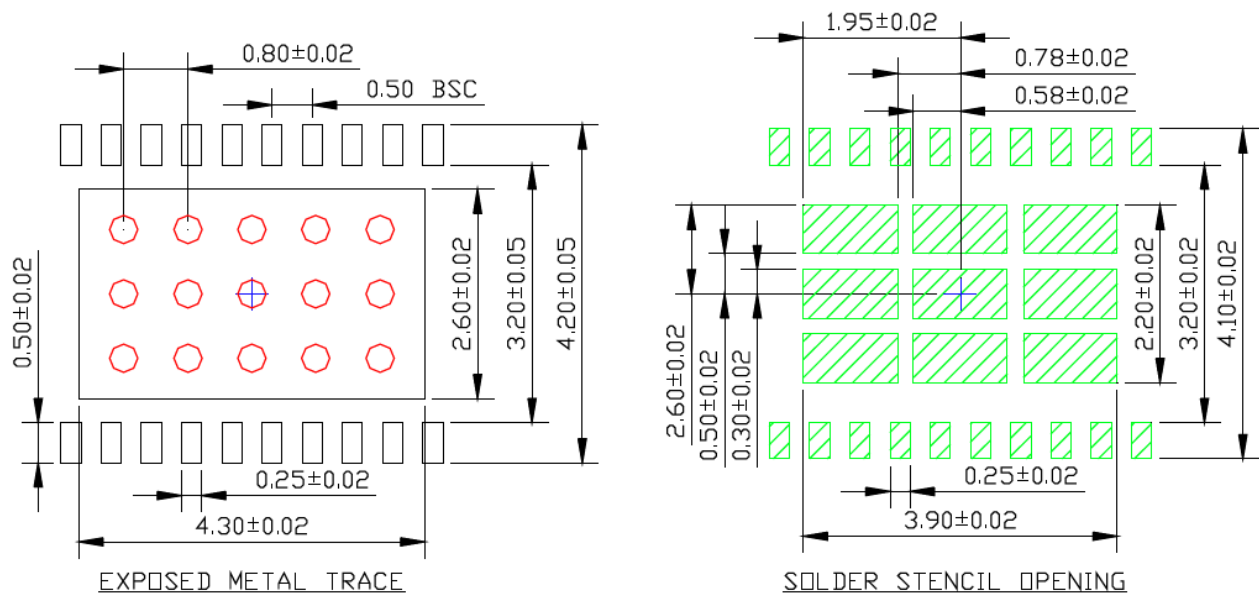

Note: For the most current package drawings, please see the Microchip Packaging Specification located at <http://www.microchip.com/packaging>.



**MICROCHIP**

---

---

**Package Outlines and Dimensions**

---

---

**NOTES:**

---

---

**Package Outlines and Dimensions**

---

---

**FBGA**

Micrel Legacy

## Package Outlines and Dimensions

### TITLE

85 LEAD FBGA 5.5x5.5mm PACKAGE OUTLINE & RECOMMENDED LAND PATTERN

DRAWING #	FPGA5555-85LD-PL-1	UNIT	INCH
-----------	--------------------	------	------

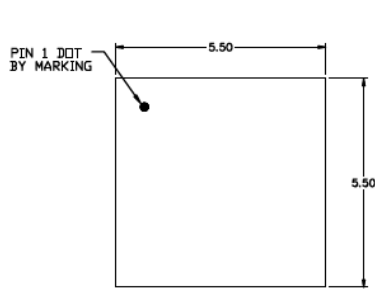

TOP VIEW

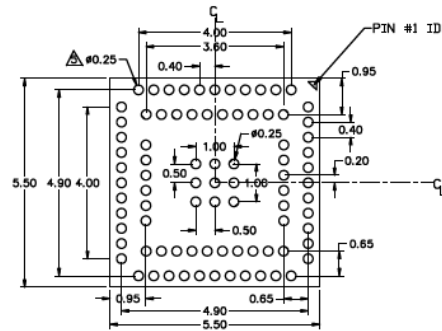

BOTTOM VIEW

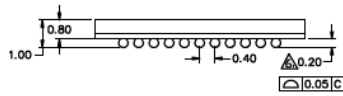

SIDE VIEW

NOTE: 1,2,3,4,5,6

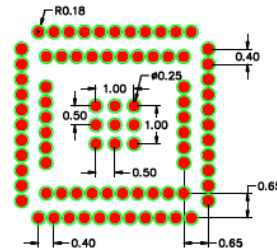

RECOMMENDED LAND PATTERN

NOTE: 7

- NOTE:
1. ALL DIMENSIONS ARE IN MILLIMETERS.
  2. MAX. PACKAGE WARPAGE IS 0.05 mm.
  3. MAXIMUM ALLOWABLE BURRS IS 0.076 mm IN ALL DIRECTIONS.
  4. PIN #1 ID ON TOP WILL BE LASER/INK MARKED.
  5. DIMENSION APPLIES TO SOLDER BUMPS AND IS MEASURED BETWEEN 0.10 AND 0.15 mm FROM TIP.
  6. APPLIED ONLY FOR TERMINALS.
  7. SHADED RED CIRCLES REPRESENTS CONTACT PAD AREA. GREEN CIRCLES REPRESENTS SOLDER MASK OPENNING.

Note: For the most current package drawings, please see the Microchip Packaging Specification located at <http://www.microchip.com/packaging>.

---

---

**Package Outlines and Dimensions**

---

---

**FDFN**

Micrel Legacy

## Package Outlines and Dimensions

### TITLE

4 LEAD FDFN 1.2x1.2 mm PACKAGE (Flip Chip) OUTLINE & RECOMMENDED LAND PATTERN

<b>DRAWING #</b>	DFDN1212-4LD-PL-1	<b>UNIT</b>	MM
<b>Lead Frame</b>	NiPdAu	<b>Lead Finish</b>	NiPdAu

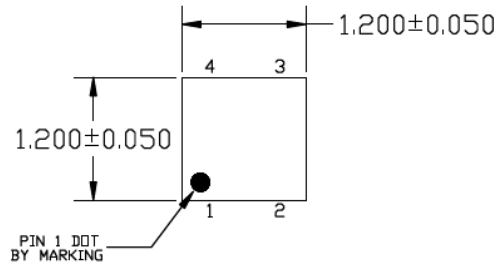

TOP VIEW  
NOTE: 1, 2, 3

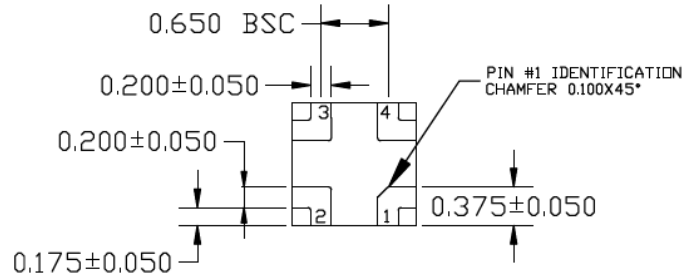

BOTTOM VIEW  
NOTE: 1, 2, 3

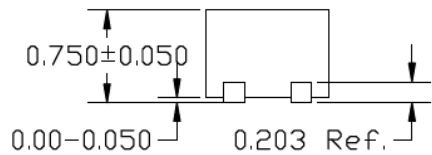

END VIEW  
NOTE: 1, 2, 3

### NOTE:

1. MAX PACKAGE WARPAGE IS 0.05 MM
2. MAX ALLOWABLE BURR IS 0.076MM IN ALL DIRECTIONS
3. PIN #1 IS ON TOP WILL BE LASER MARKED
4. CYAN SHADED AREAS INDICATE OPTIONAL SOLDER STENCIL OPENING FOR IMPROVED THERMAL PERFORMANCE

Note: For the most current package drawings, please see the Microchip Packaging Specification located at <http://www.microchip.com/packaging>.

**Package Outlines and Dimensions**

POD-Land Pattern drawing #FDFN1212-4LD-PL-1

RECOMMENDED LAND PATTERN

NOTE: 4

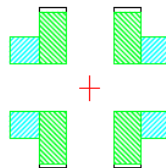

STACKED-UP

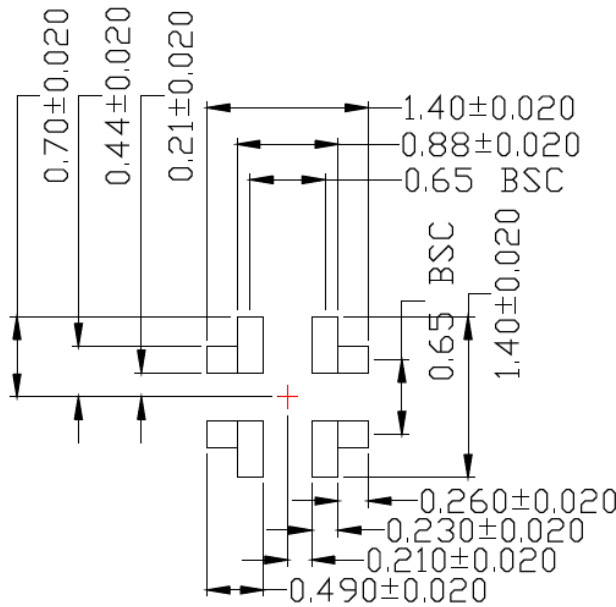

EXPOSED METAL TRACE

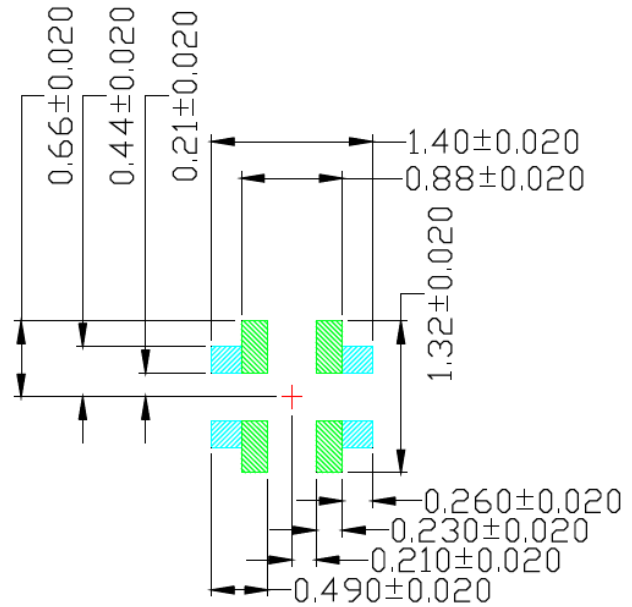

SOLDER STENCIL OPENING

Note: For the most current package drawings, please see the Microchip Packaging Specification located at <http://www.microchip.com/packaging>.

**Package Outlines and Dimensions**

**TITLE**

10 LEAD FDFN 3x4mm PACKAGE OUTLINE & RECOMMENDED LAND PATTERN

DRAWING #	FDFN34-10LD-PL-9	UNIT	MM
-----------	------------------	------	----

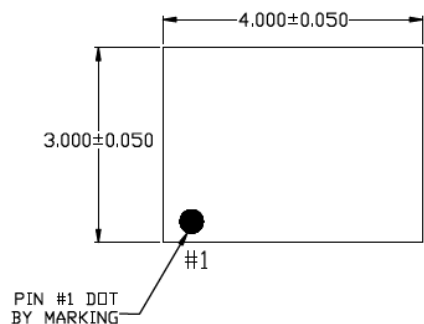

TOP VIEW

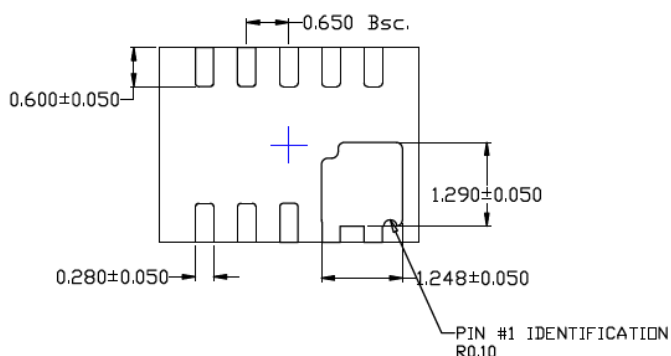

BOTTOM VIEW

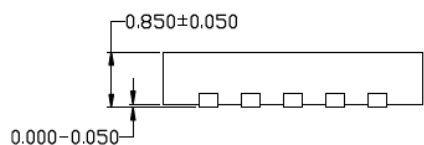

SIDE VIEW

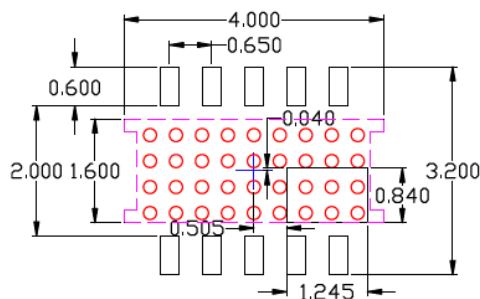

RECOMMENDED  
LAND PATTERN

NOTE :

1. Max package warpage is 0.05mm
2. Max allowable burr is 0.076mm in all directions
3. Pin #1 will be laser marked
4. Red circle in land pattern indicate thermal via.  
Size should be 0.20mm in diameter, 0.40mm pitch  
& connected to GND for max thermal performance.
5. Purple hidden lines are recommended metal trace/  
GND planes for improved thermal performance.

Note: For the most current package drawings, please see the Microchip Packaging Specification located at <http://www.microchip.com/packaging>.



---



---

## Package Outlines and Dimensions

---



---

**TITLE**

10 LEAD DFN 4x3mm PACKAGE (Flip Chip) OUTLINE &amp; RECOMMENDED LAND PATTERN

<b>DRAWING #</b>	FDN43-10LD-PL-1	<b>UNIT</b>	MM
<b>Lead Frame</b>	Copper	<b>Lead Finish</b>	Matte Tin

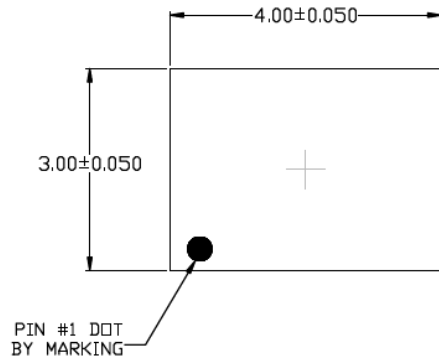

TOP VIEW  
NOTE: 1, 2, 3

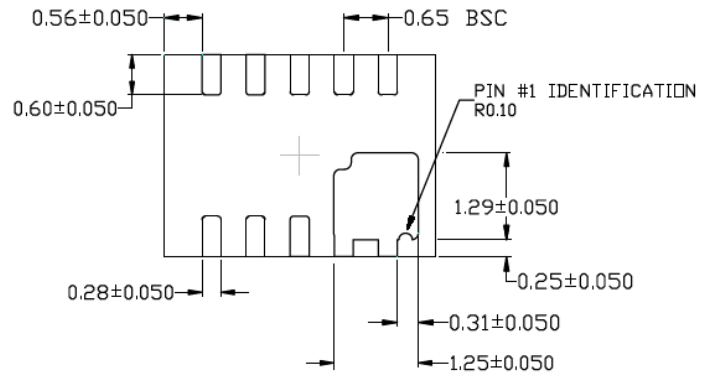

BOTTOM VIEW  
NOTE: 1, 2

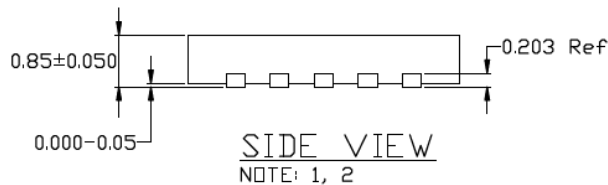

SIDE VIEW  
NOTE: 1, 2

**NOTE:**

1. MAX PACKAGE WARPAGE IS 0.05MM
2. MAX ALLOWABLE BURR IS 0.076MM IN ALL DIRECTIONS
3. PIN #1 IS ON TOP WILL BE LASER MARKED
4. GREEN RECTANGLES (SHADED AREA) REPRESENT STENCIL OPENING ON EXPOSED AREA. SIZE IS 0.85X0.87 MM, 1.07 MM PITCH SPACING
5. RED CIRCLES REPRESENT THERMAL VIAS & SHOULD BE CONNECTED TO GND FOR MAX PERFORMANCE. 0.30 - 0.35 MM RECOMMENDED DIAMETER, 0.80MM PITCH SPACING

Note: For the most current package drawings, please see the Microchip Packaging Specification located at <http://www.microchip.com/packaging>.

**Package Outlines and Dimensions**

POD-Land Pattern drawing #FDFN43-10LD-PL-1

RECOMMENDED LAND PATTERN

NOTE: 4, 5

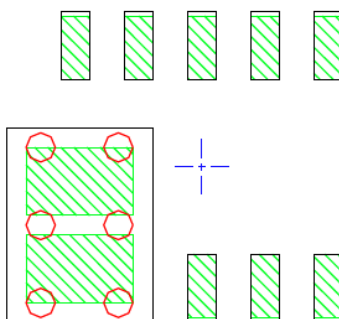

STACKED-UP

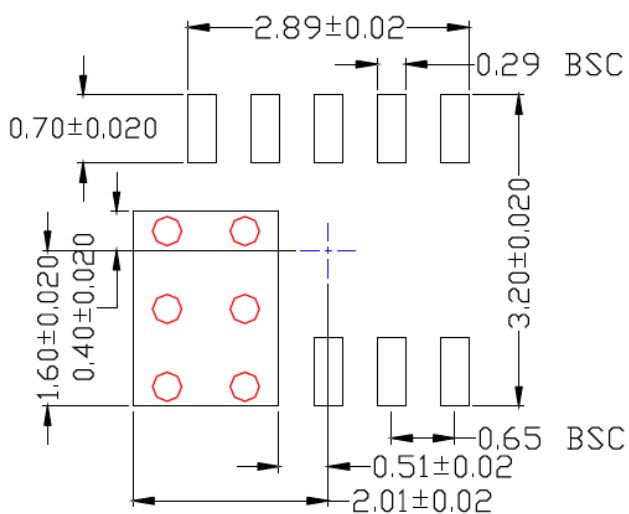

EXPOSED METAL TRACE

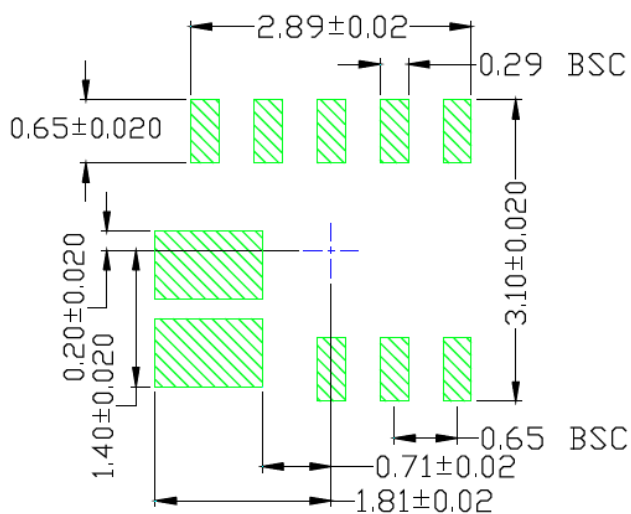

SOLDER STENCIL OPENING

Note: For the most current package drawings, please see the Microchip Packaging Specification located at <http://www.microchip.com/packaging>.

---

---

**Package Outlines and Dimensions**

---

---

**FQFN**

Micrel Legacy

## Package Outlines and Dimensions

### TITLE

10 LEAD FQFN 1.2x2.0 mm PACKAGE (Flip Chip) OUTLINE & RECOMMENDED LAND PATTERN

<b>DRAWING #</b>	FQFN1220-10LD-PL-1	<b>UNIT</b>	MM
<b>Lead Frame</b>	Copper	<b>Lead Finish</b>	Matte Tin

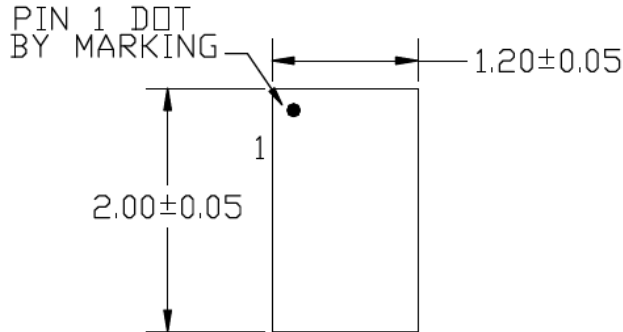

TOP VIEW

NOTE: 1, 2, 3

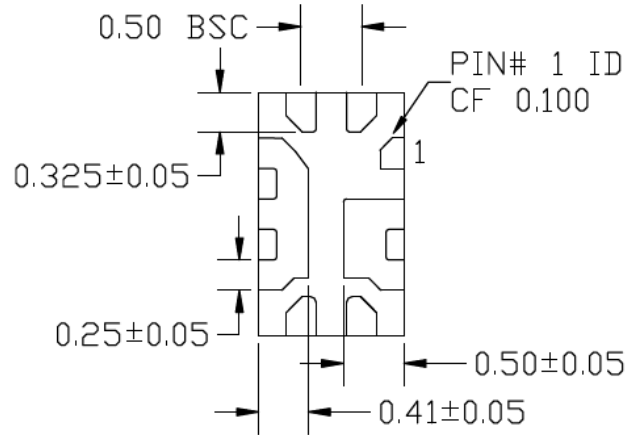

BOTTOM VIEW

NOTE: 1, 2, 3

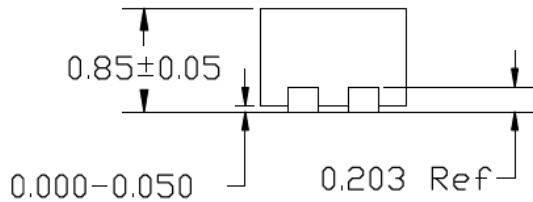

END VIEW

NOTE: 1, 2, 3

### NOTE:

1. MAX PACKAGE WARPAGE IS 0.05mm.
2. MAX ALLOWABLE BURR IS 0.076mm IN ALL DIRECTIONS.
3. PIN #1 IS ON TOP WILL BE LASER MARKED.
4. GREEN SHADED RECTANGLES (AREA) REPRESENTS SOLDER STENCIL OPENING ON EXPOSED METAL TRACE.
5. CYAN SHADED AREAS INDICATE OPTIONAL SOLDER STENCIL OPENING FOR IMPROVED THERMAL PERFORMANCE.

Note: For the most current package drawings, please see the Microchip Packaging Specification located at <http://www.microchip.com/packaging>.

**Package Outlines and Dimensions**

POD-Land Pattern drawing #FQFN1220-10LD-PL-1

RECOMMENDED LAND PATTERN

NOTE: 4, 5

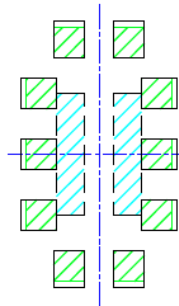

STACKED-UP

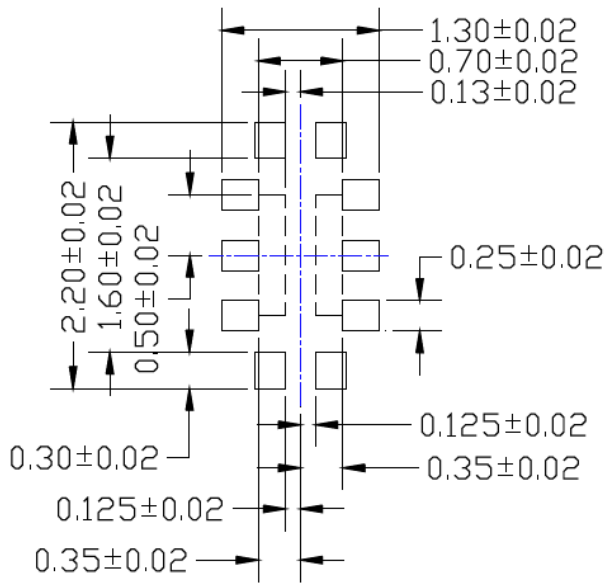

EXPOSED METAL TRACE

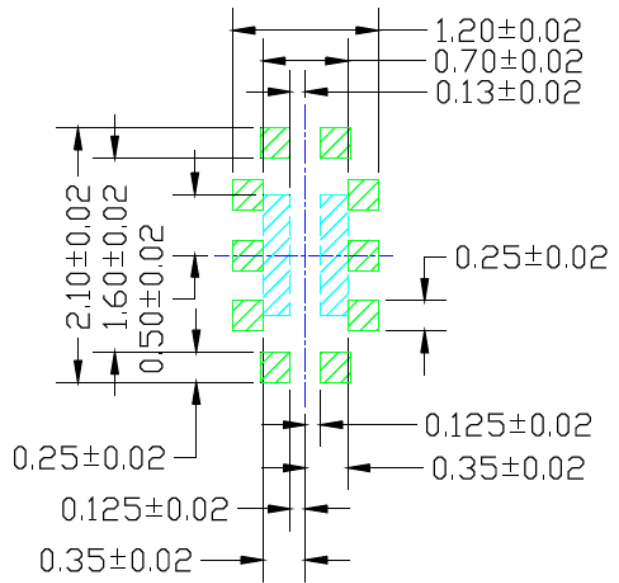

SOLDER STENCIL OPENING

Note: For the most current package drawings, please see the Microchip Packaging Specification located at <http://www.microchip.com/packaging>.

## Package Outlines and Dimensions

### TITLE

16 LEAD FQFN 3X3 mm PACKAGE OUTLINE & RECOMMENDED LAND PATTERN

DRAWING #	FQFN33-16LD-PL-1	UNIT	MM
-----------	------------------	------	----

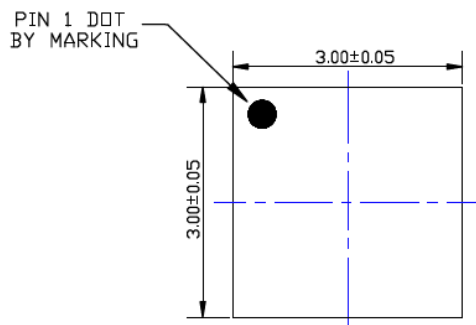

TOP VIEW  
NOTE: 1, 2, 3

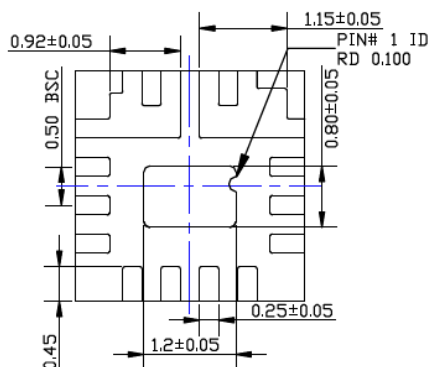

BOTTOM VIEW  
NOTE: 1, 2, 3

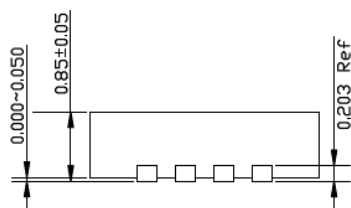

SIDE VIEW  
NOTE: 1, 2, 3

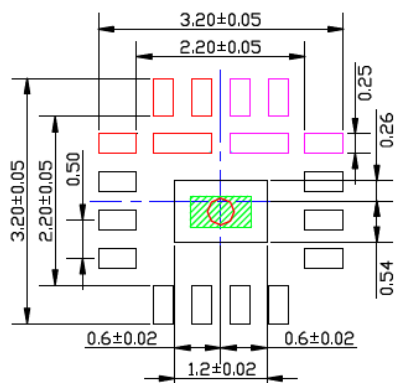

RECOMMENDED LAND PATTERN  
NOTE: 4, 5, 6

### NOTE :

1. Max package warpage is 0.05mm
2. Max allowable burr is 0.076mm in all directions
3. Pin #1 will be laser marked
4. Red circle in land pattern indicate thermal via. Size should be 0.30~0.35mm in diameter and should be connected to GND for max thermal performance.
5. Green rectangle (shaded area) in GND black colored pad represent stencil opening on exposed area. Size is 0.80x0.40mm.
6. Red & Magenta colored pads represent different potentials, do not connect to GND.

Note: For the most current package drawings, please see the Microchip Packaging Specification located at <http://www.microchip.com/packaging>.

## Package Outlines and Dimensions

**TITLE**

20 LEAD FQFN 3x3mm PACKAGE (Flip Chip) OUTLINE & RECOMMENDED LAND PATTERN

<b>DRAWING #</b>	FQFN33-20LD-PL-1	<b>UNIT</b>	MM
<b>Lead Frame</b>	Cu	<b>Lead Finish</b>	Matte Tin

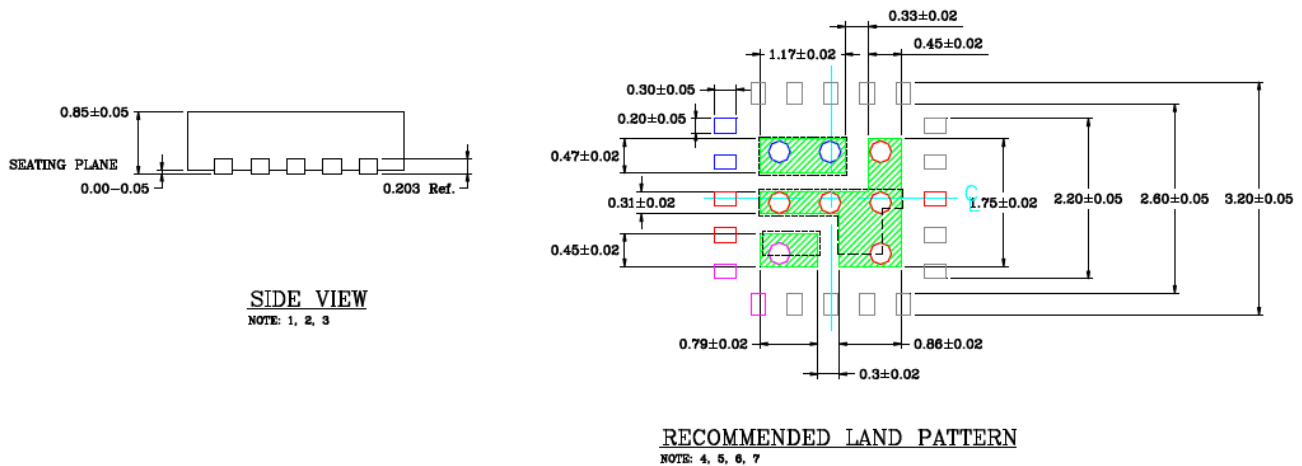
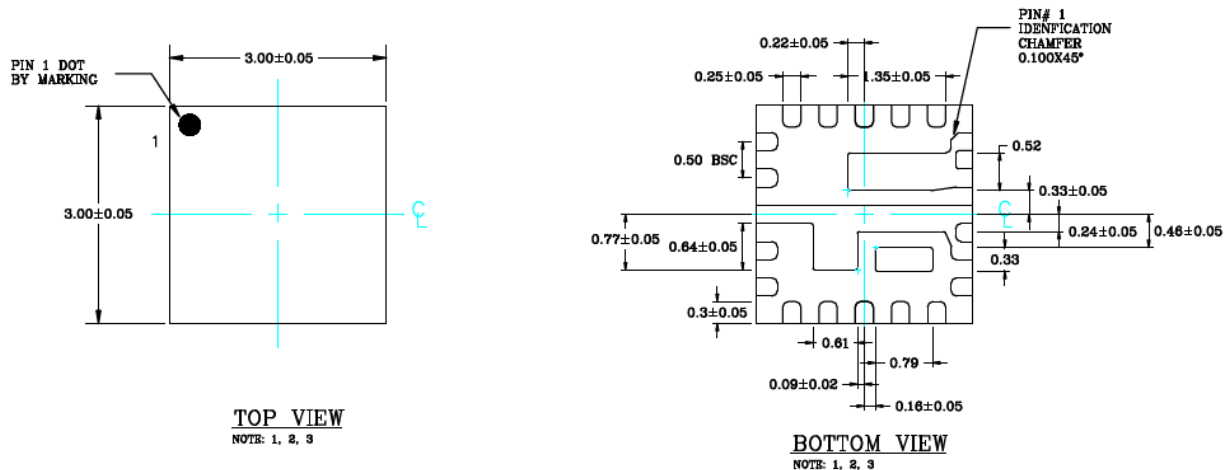

**NOTE:**

1. MAX PACKAGE WARPAGE IS 0.05mm.
2. MAX ALLOWABLE BURR IS 0.076mm IN ALL DIRECTIONS.
3. PIN #1 (TOP) IS LASER MARKED.
4. RED CIRCLES IN LAND PATTERN REPRESENTS THERMAL VIA AND SHOULD BE CONNECTED TO GROUND FOR MAXIMUM PERFORMANCE.
5. GREEN RECTANGLES (SHADED AREA) ARE RECOMMENDED SOLDER STENCIL OPENNING ON EXPOSED PAD AREA.
6. BLUE COLOR AND PURPLE COLOR PADS REPRESENT DIFFERENT POTENTIALS. DO NOT CONNECT TO GROUND.
7. VIA SIZE IS 0.30mm DIAMETER AND 0.70mm PITCH.

Note: For the most current package drawings, please see the Microchip Packaging Specification located at <http://www.microchip.com/packaging>.

## Package Outlines and Dimensions

### TITLE

20 LEAD FQFN 3.5x3.5mm PACKAGE (Flip Chip) OUTLINE & RECOMMENDED LAND PATTERN

DRAWING #	FQFN3535-20LD-PL-1	UNIT	MM
Lead Frame	NiPdAu	Lead Finish	NiPdAu

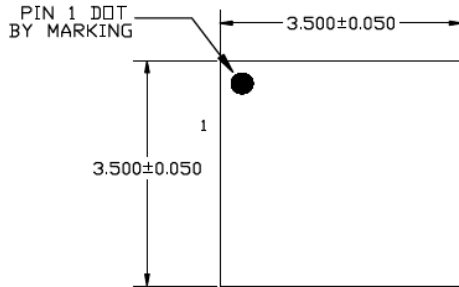

TOP VIEW  
NOTE: 1, 2, 3

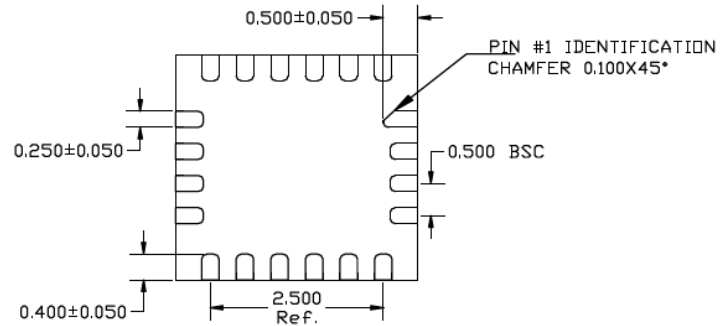

BOTTOM VIEW  
NOTE: 1, 2, 3

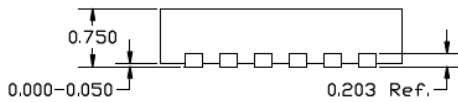

SIDE VIEW  
NOTE: 1, 2, 3

### NOTE:

1. MAX PACKAGE WARPAGE IS 0.05 MM
2. MAX ALLOWABLE BURR IS 0.076MM IN ALL DIRECTIONS
3. PIN #1 IS ON TOP WILL BE LASER MARKED
4. GREEN SHADED RECTANGLES (AREA) REPRESENT SOLDER STENCIL OPENING ON EXPOSED METAL TRACE

Note: For the most current package drawings, please see the Microchip Packaging Specification located at <http://www.microchip.com/packaging>.



**Package Outlines and Dimensions**

POD-Land Pattern drawing #FQFN3535-20LD-PL-1

RECOMMENDED LAND PATTERN

NOTE: 4

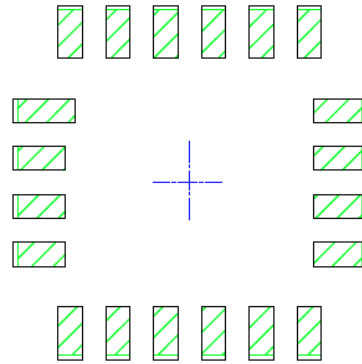

STACKED-UP

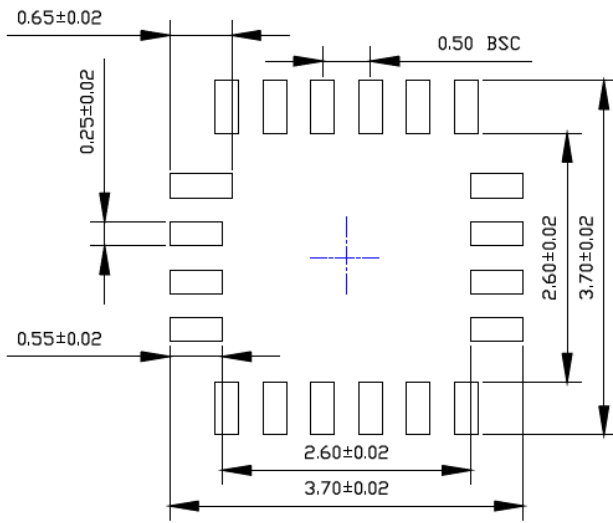

EXPOSED METAL TRACE

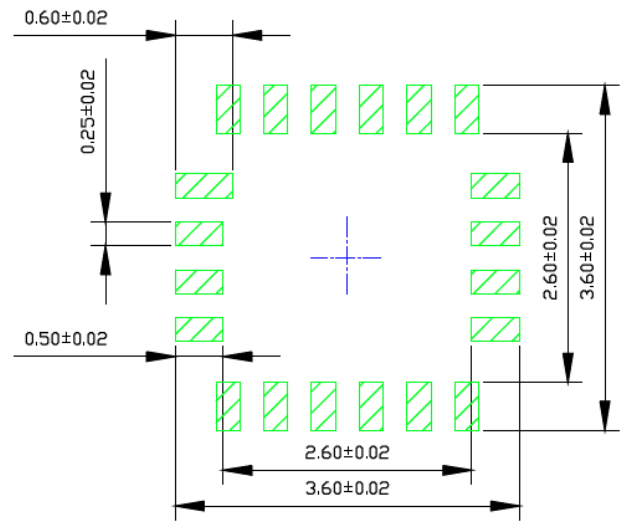

SOLDER STENCIL OPENING

Note: For the most current package drawings, please see the Microchip Packaging Specification located at <http://www.microchip.com/packaging>.

## Package Outlines and Dimensions

### TITLE

20 LEAD QFN 3x4mm PACKAGE (Flip Chip) OUTLINE & RECOMMENDED LAND PATTERN

DRAWING #	FQFN34-20LD-PL-1	UNIT	MM
Lead Frame	NiPdAu	Lead Finish	NiPdAu

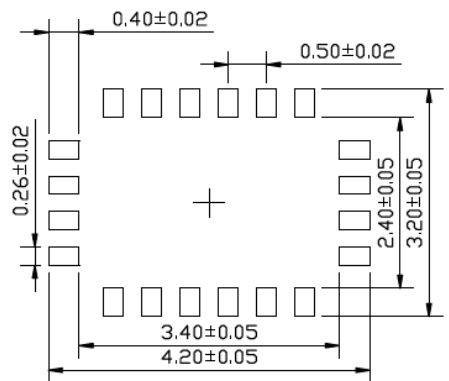
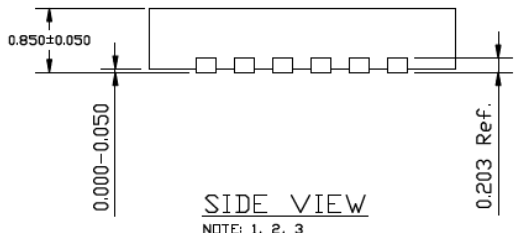
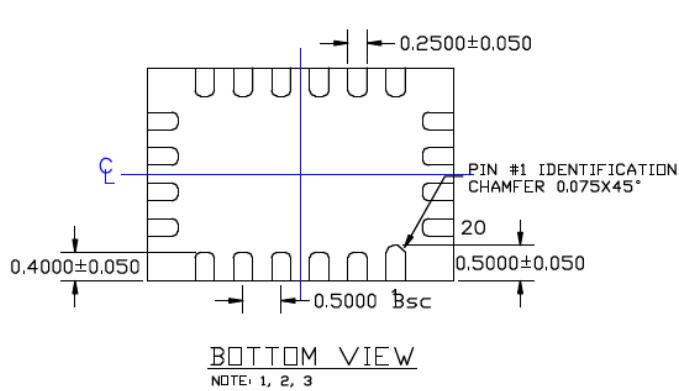
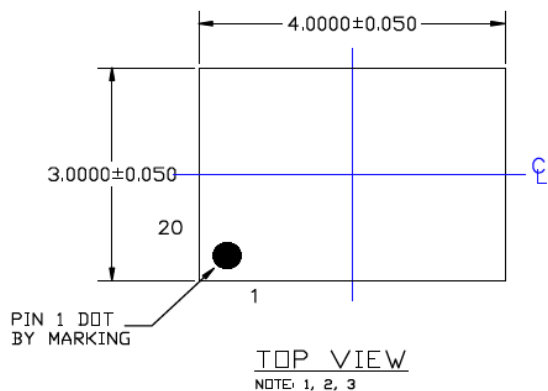

- NOTE:
1. MAX PACKAGE WARPAGE IS 0.05 MM
  2. MAX ALLOWABLE BURR IS 0.076MM IN ALL DIRECTIONS
  3. PIN #1 IS ON TOP WILL BE LASER MARKED

Note: For the most current package drawings, please see the Microchip Packaging Specification located at <http://www.microchip.com/packaging>.

**Package Outlines and Dimensions**

**TITLE**

24 LEAD QFN 3x3mm PACKAGE (Flip Chip) OUTLINE & RECOMMENDED LAND PATTERN

<b>DRAWING #</b>	FQFN33-24LD-PL-1	<b>UNIT</b>	MM
<b>Lead Frame</b>	NiPdAu	<b>Lead Finish</b>	NiPdAu

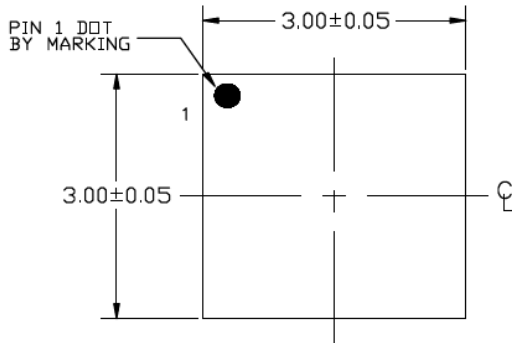

TOP VIEW  
NOTE: 1, 2, 3

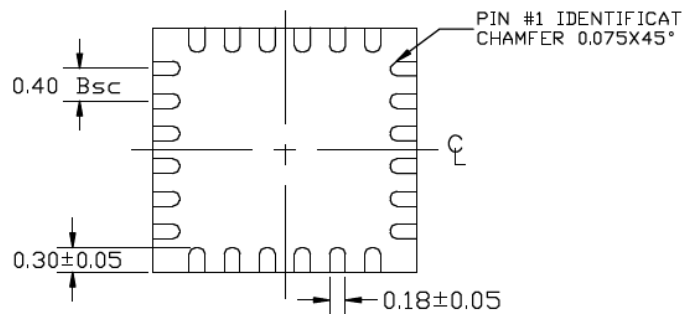

BOTTOM VIEW  
NOTE: 1, 2, 3

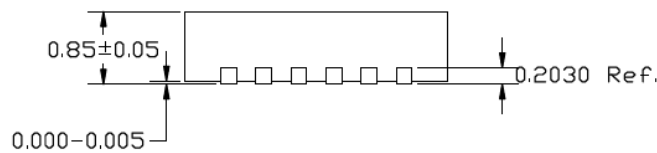

SIDE VIEW  
NOTE: 1, 2, 3

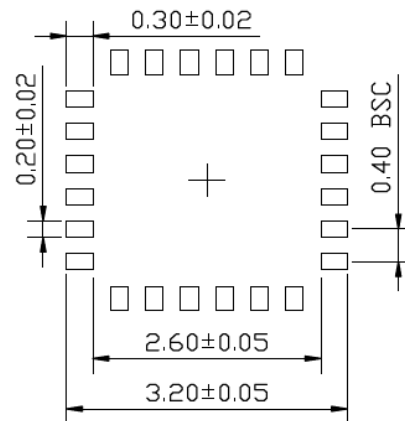

RECOMMENDED LAND PATTERN

**NOTE:**

1. MAX PACKAGE WARPAGE IS 0.05 MM
2. MAX ALLOWABLE BURR IS 0.076MM IN ALL DIRECTIONS
3. PIN #1 IS ON TOP WILL BE LASER MARKED

Note: For the most current package drawings, please see the Microchip Packaging Specification located at <http://www.microchip.com/packaging>.

## Package Outlines and Dimensions

### TITLE

24 LEAD QFN 3x4mm PACKAGE (Flip Chip) OUTLINE & RECOMMENDED LAND PATTERN

<b>DRAWING #</b>	FQFN34-24LD-PL-1	<b>UNIT</b>	MM
<b>Lead Frame</b>	NiPdAu	<b>Lead Finish</b>	NiPdAu

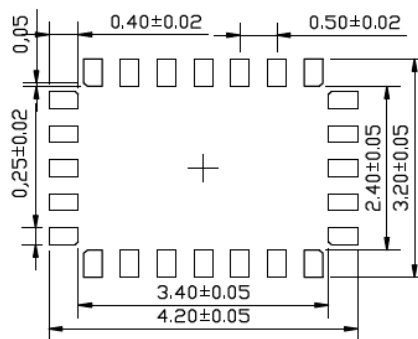
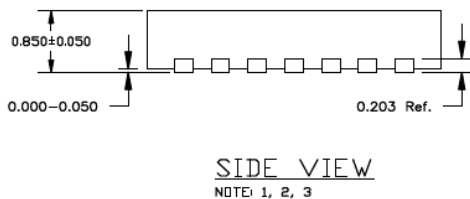
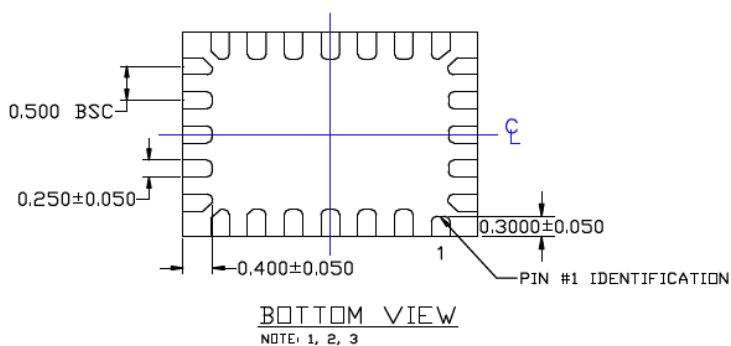
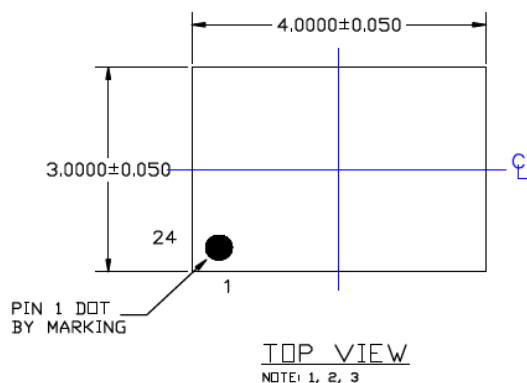

#### NOTE:

1. MAX PACKAGE WARPAGE IS 0.05 MM
2. MAX ALLOWABLE BURR IS 0.076MM IN ALL DIRECTIONS
3. PIN #1 IS ON TOP WILL BE LASER MARKED

Note: For the most current package drawings, please see the Microchip Packaging Specification located at <http://www.microchip.com/packaging>.

---



---

## Package Outlines and Dimensions

---



---

**TITLE**

24 LEAD QFN 3x4mm PACKAGE OUTLINE &amp; RECOMMENDED LAND PATTERN

<b>DRAWING #</b>	FQFN34-24LD-PL-2	<b>UNIT</b>	MM
<b>Lead Frame</b>	Copper	<b>Lead Finish</b>	Matte Tin

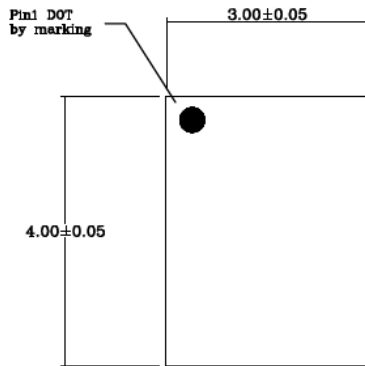

Top View

Note 1.2.3

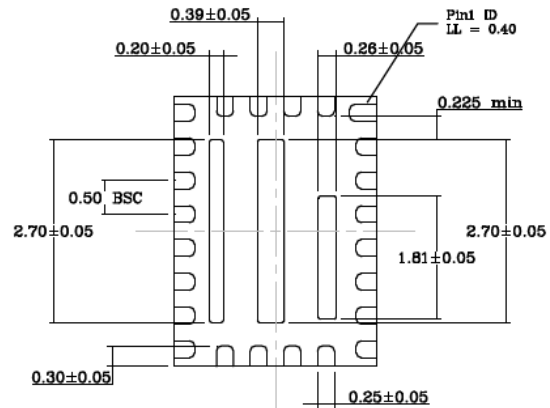

Bottom View

Note 1.2.3

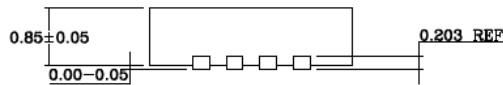

Side View

Note 1.2.3

**NOTE:**

1. MAX PACKAGE WARPAGE IS 0.05mm.
2. MAX ALLOWABLE BURR IS 0.076mm IN ALL DIRECTIONS.
3. PIN #1 IS ON TOP WILL BE LASER MARKED.
4. **RED** CIRCLES IN LAND PATTERN REPRESENT THERMAL VIAs & SHOULD BE CONNECTED TO GND FOR MAXIMUM PERFORMANCE. SIZE IS 0.30-0.35mm WITH 0.80mm PITCH.
5. SHADED AREA RECTANGLES REPRESENT SOLDER STENCIL OPENING ON EXPOSED METAL TRACE.
6. **MAGENTA** & **BLUE** COLORED RECTANGLES REPRESENT DIFFERENT POTENTIAL, DO NOT CONNECT TO GND.
7. **BLACK** COLORED RECTANGLES REPRESENT DIFFERENT IOs. DO NOT CONNECT TOGETHER.
8. RECOMMENDED LAND PATTERN TOLERANCE IS 0.02mm UNLESS SPECIFIED.
9. SEE RECOMMENDED LAND PATTERN ON PAGE 2.

Note: For the most current package drawings, please see the Microchip Packaging Specification located at <http://www.microchip.com/packaging>.

**Package Outlines and Dimensions**

POD-Land Pattern Doc #: FQFN34-24LD-PL-2-E

**Recommended Land Pattern**

Note: 4,5,6,7

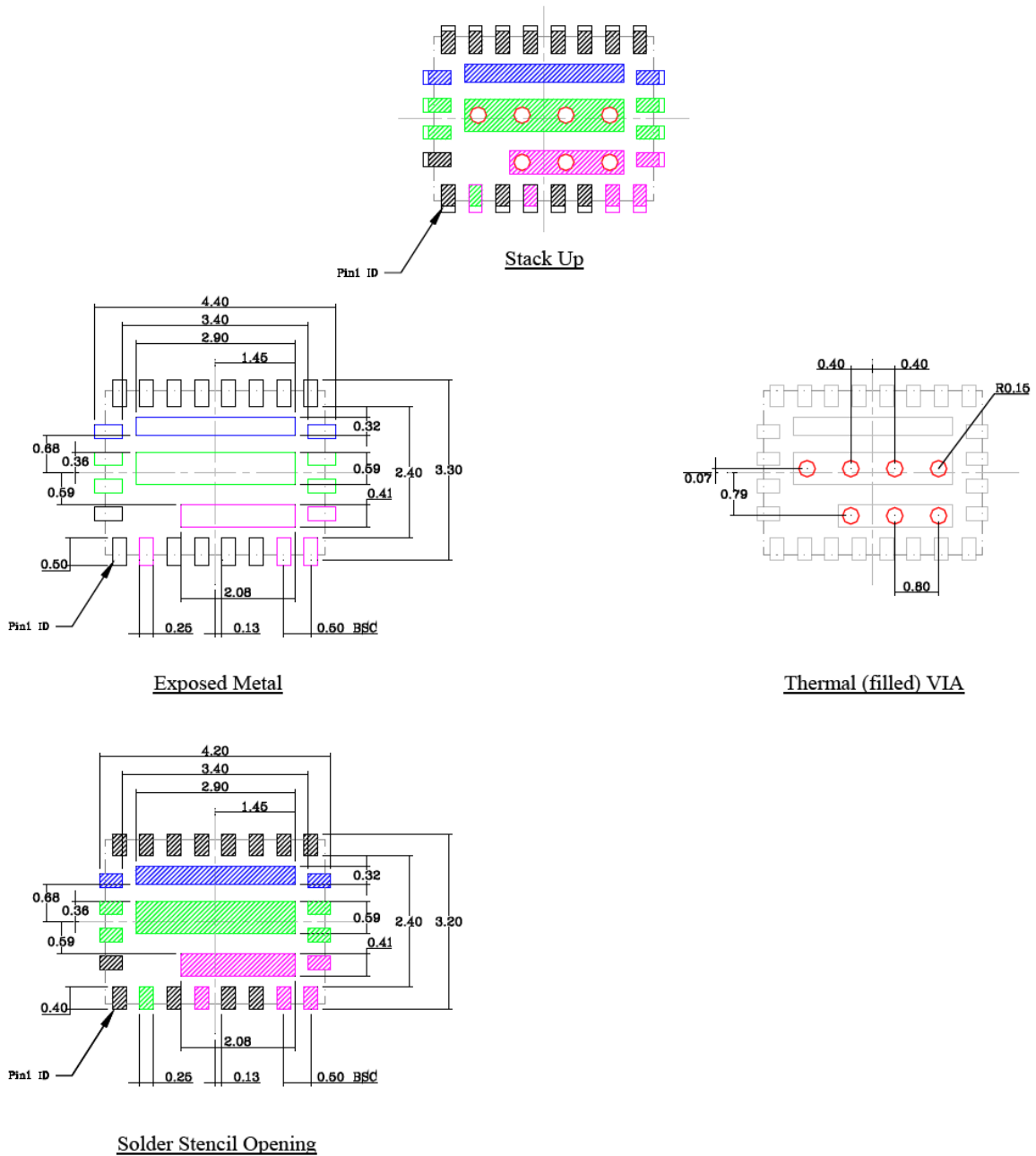

Note: For the most current package drawings, please see the Microchip Packaging Specification located at <http://www.microchip.com/packaging>.

---



---

## Package Outlines and Dimensions

---



---

**TITLE**

26 LEAD FQFN 4x4mm PACKAGE (Flip Chip) OUTLINE &amp; RECOMMENDED LAND PATTERN

DRAWING #	FQFN44-26LD-PL-1	UNIT	MM
-----------	------------------	------	----

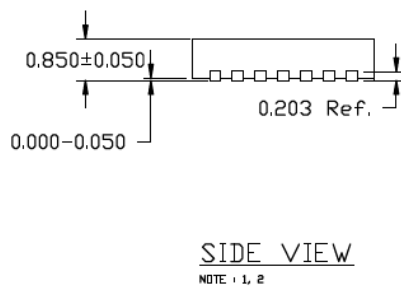
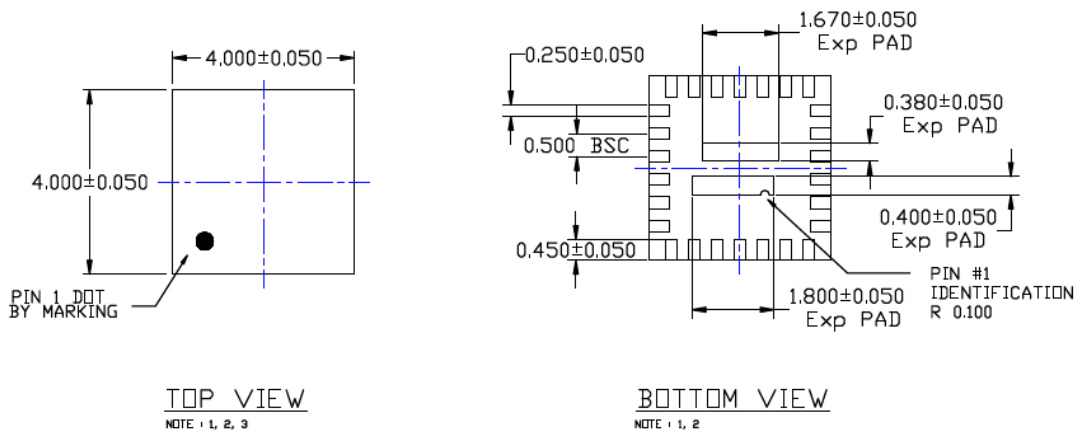
**NOTE:**

1. Max package warpage is 0.05mm.
2. Max allowable burr is 0.076mm in all directions.
3. Pin #1 will be laser marked.
4. Red circle in PGND indicate thermal via. Size should be 0.20mm in diameter, 0.40mm pitch and should be connected to GND for max thermal performance.
5. Blue colored pad & circle indicate SGND, do not connect to GND.

Note: For the most current package drawings, please see the Microchip Packaging Specification located at <http://www.microchip.com/packageing>.

**Package Outlines and Dimensions**

POD-Land Pattern drawing #FQFN44-26LD-PL-1

RECOMMENDED LAND PATTERN

NOTE : 4, 5

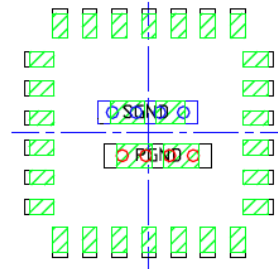

STACKED-UP

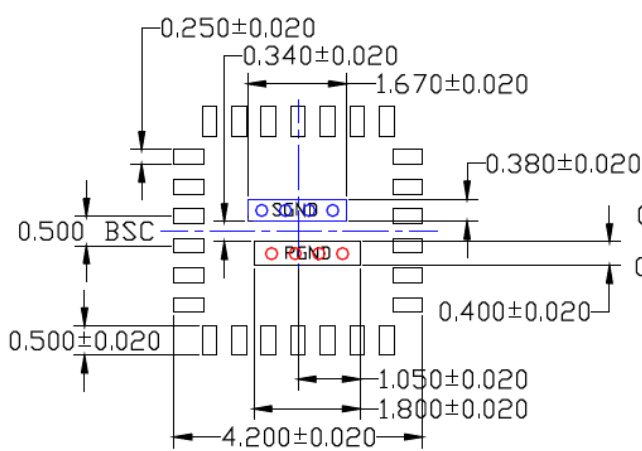

EXPOSED METAL TRACE

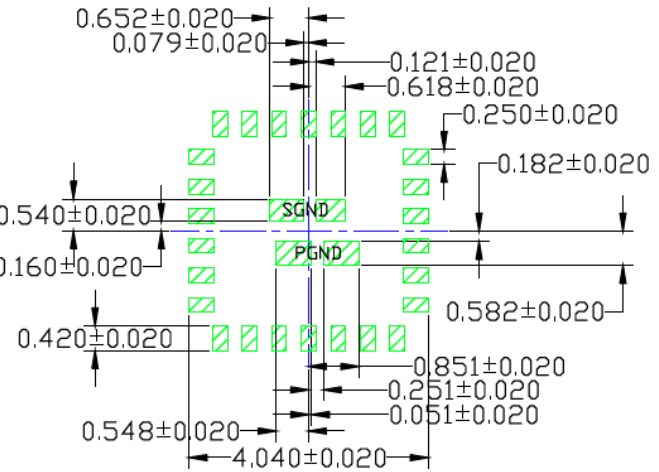

SOLDER STENCIL OPENING

Note: For the most current package drawings, please see the Microchip Packaging Specification located at <http://www.microchip.com/packaging>.



---



---

## Package Outlines and Dimensions

---



---

**TITLE**

28 LEAD FQFN 4x4mm PACKAGE OUTLINE &amp; RECOMMENDED LAND PATTERN

DRAWING #	FQFN44-28LD-PL-1	UNIT	MM
Lead Frame	Copper	Lead Finish	Matte Tin

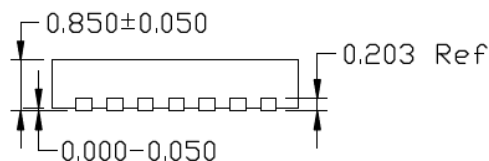
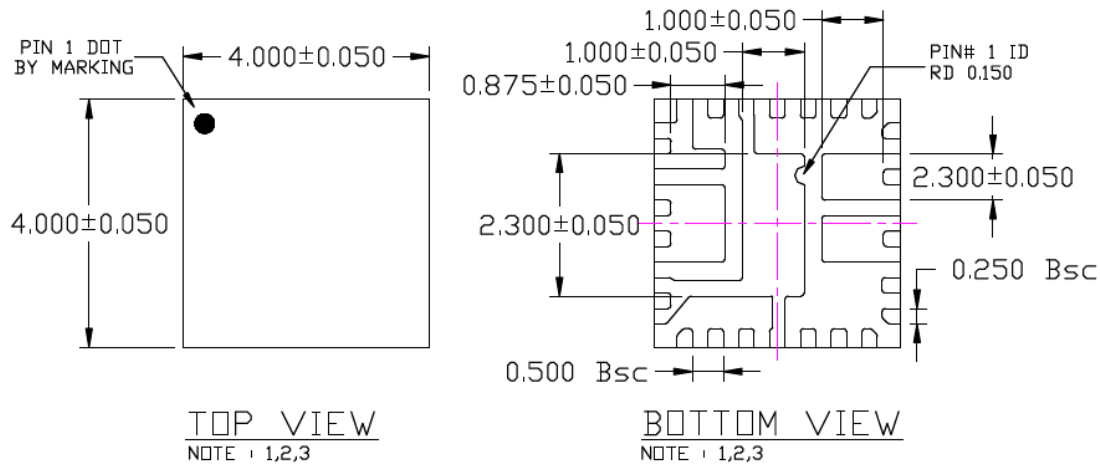

SIDE VIEW

NOTE : 1,2,3

**NOTE :**

1. Max package warpage is 0.05mm.
2. Max allowable burr is 0.076mm in all directions.
3. Pin #1 will be laser marked.
4. Red circle in land pattern indicate thermal via. Size should be 0.20mm in diameter, 0.400mm pitch and should be connected to GND for max thermal performance.
5. Green rectangles (shaded area) in GND pad represent stencil opening on exposed area. Size is 0.600x0.825mm, pitch is 1.025mm.
6. Cyan colored hidden lines should be covered with solder mask.

Note: For the most current package drawings, please see the Microchip Packaging Specification located at <http://www.microchip.com/packaging>.

**Package Outlines and Dimensions**

POD-Land Pattern drawing #FQFN44-28LD-PL-1

RECOMMENDED LAND PATTERN

NOTE : 4,5,6

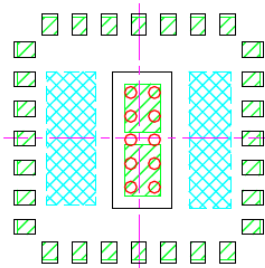

STACKED-UP

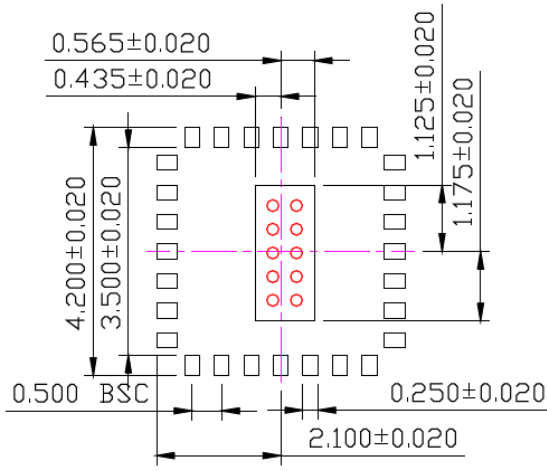

EXPOSED METAL TRACE

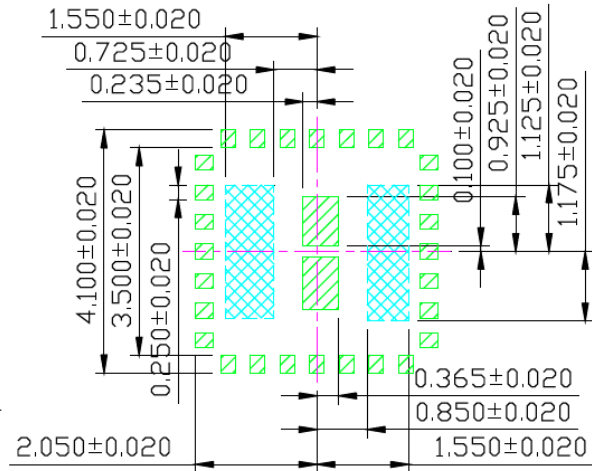

SOLDER STENCIL OPENING

Note: For the most current package drawings, please see the Microchip Packaging Specification located at <http://www.microchip.com/packaging>.

**Package Outlines and Dimensions**

**TITLE**

28 LEAD QFN 5x5mm PACKAGE (Flip Chip) OUTLINE & RECOMMENDED LAND PATTERN

<b>DRAWING #</b>	FQFN55-28LD-PL-1	<b>UNIT</b>	MM
<b>Lead Frame</b>	NiPdAu	<b>Lead Finish</b>	NiPdAu

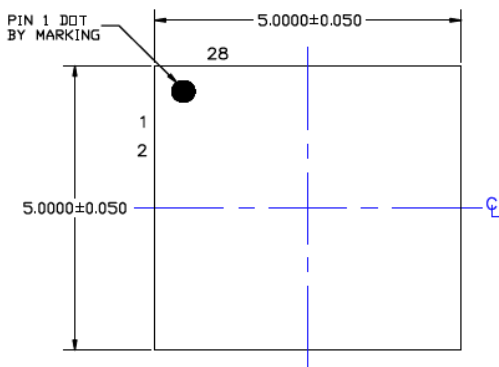

TOP VIEW  
NOTE: 1, 2, 3

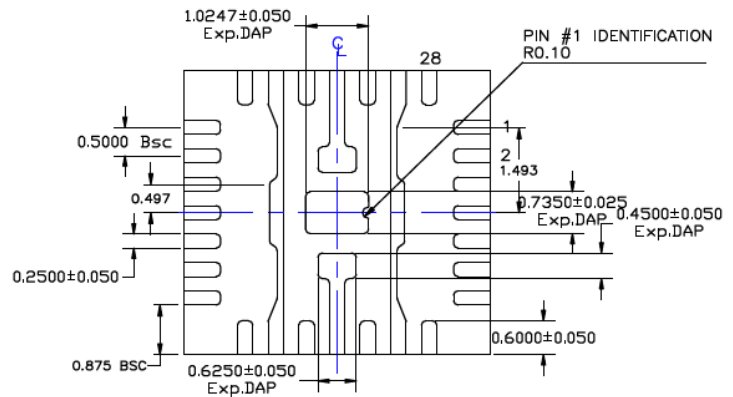

BOTTOM VIEW  
NOTE: 1, 2, 3

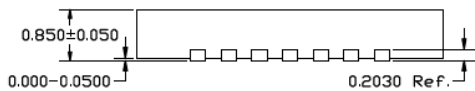

SIDE VIEW  
NOTE: 1, 2, 3

**NOTE:**

1. MAX PACKAGE WARPAGE IS 0.05 MM
2. MAX ALLOWABLE BURR IS 0.076 MM IN ALL DIRECTIONS
3. PIN #1 IS ON TOP WILL BE LASER MARKED
4. RED CIRCLE IN LAND PATTERN INDICATE THERMAL VIA. SIZE SHOULD BE 0.30-0.35 MM IN DIAMETER AND SHOULD BE CONNECTED TO GND FOR MAX THERMAL PERFORMANCE
5. NO EXPOSED TRACES ALLOWED WITHIN THE CYAN COLORED SHADED AREA. 

Note: For the most current package drawings, please see the Microchip Packaging Specification located at <http://www.microchip.com/packaging>.

**Package Outlines and Dimensions**

POD-Land Pattern drawing #FQFN55-28LD-PL-1

RECOMMENDED LAND PATTERN

NOTE: 4, 5

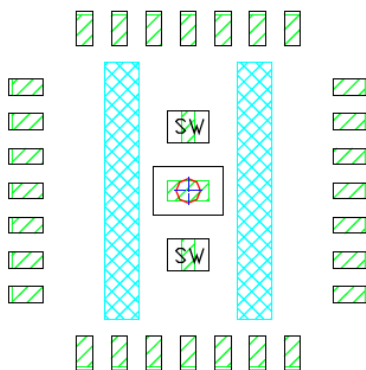

STACKED-UP

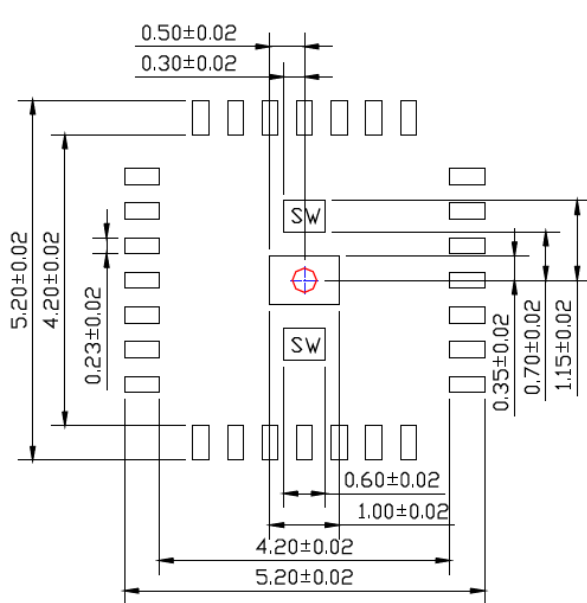

EXPOSED METAL TRACE

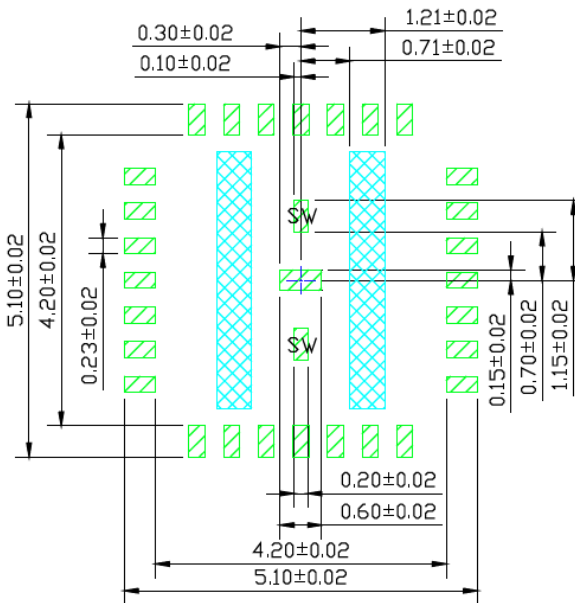

SOLDER STENCIL OPENING

Note: For the most current package drawings, please see the Microchip Packaging Specification located at <http://www.microchip.com/packaging>.

---



---

## Package Outlines and Dimensions

---



---

**TITLE**

29 LEAD FQFN 3x5mm (TRI-SIDE) PACKAGE (Flip Chip) OUTLINE &amp; RECOMMENDED LAND PATTERN

<b>DRAWING #</b>	FQFN35-29LD-PL-1	<b>UNIT</b>	MM
<b>Lead Frame</b>	NiPdAu	<b>Lead Finish</b>	NiPdAu

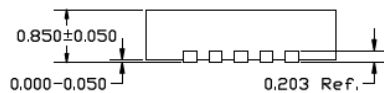
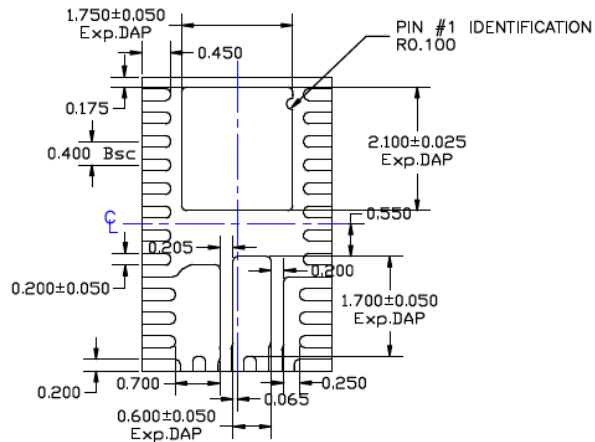
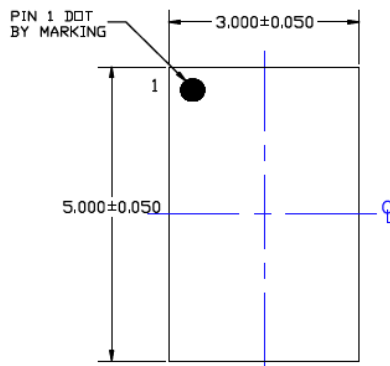
**NOTE:**

1. MAX PACKAGE WARPAGE IS 0.05 MM
2. MAX ALLOWABLE BURR IS 0.076 MM IN ALL DIRECTIONS
3. PIN #1 IS ON TOP WILL BE LASER MARKED
4. RED CIRCLES IN LAND PATTERN REPRESENT THERMAL VIA. SIZE SHOULD BE 0.30-0.35 MM IN DIAMETER AND SHOULD BE CONNECTED TO GND FOR MAX THERMAL PERFORMANCE. 1.0MM PITCH
5. GREEN RECTANGLES (SHADED AREA) REPRESENT SOLDER STENCIL OPENING ON EXPOSED PAD AREA. RECOMMENDED SIZE IS 0.73x1.30 MM, SPACING IS 0.2MM

Note: For the most current package drawings, please see the Microchip Packaging Specification located at <http://www.microchip.com/package>.

**Package Outlines and Dimensions**

POD-Land Pattern drawing # FQFN35-29LD-PL-1

**RECOMMENDED LAND PATTERN**

NOTE: 4, 5

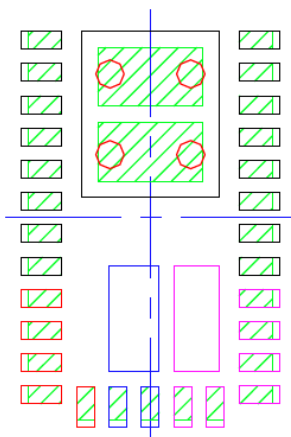

**STACKED-UP**

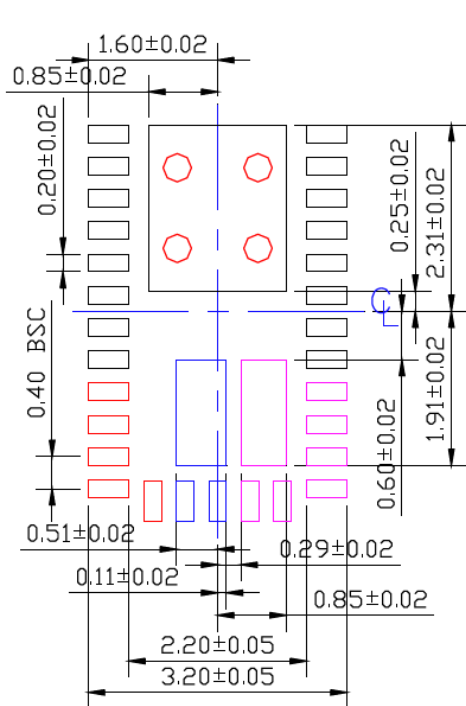

**EXPOSED METAL TRACE**

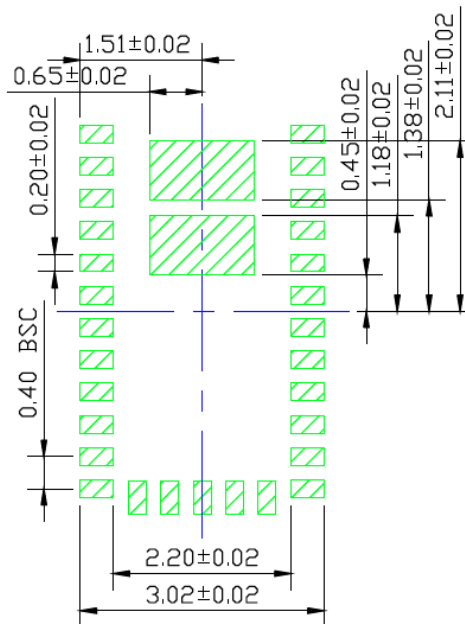

**SOLDER STENCIL OPENING**

Note: For the most current package drawings, please see the Microchip Packaging Specification located at <http://www.microchip.com/packaging>.

---



---

## Package Outlines and Dimensions

---



---

**TITLE**

32 LEAD QFN 5x5mm PACKAGE (Flip Chip) OUTLINE &amp; RECOMMENDED LAND PATTERN

DRAWING #	FQFN55-32LD-PL-1	UNIT	MM
<b>Lead Frame</b>	Copper	<b>Lead Finish</b>	Matte Tin

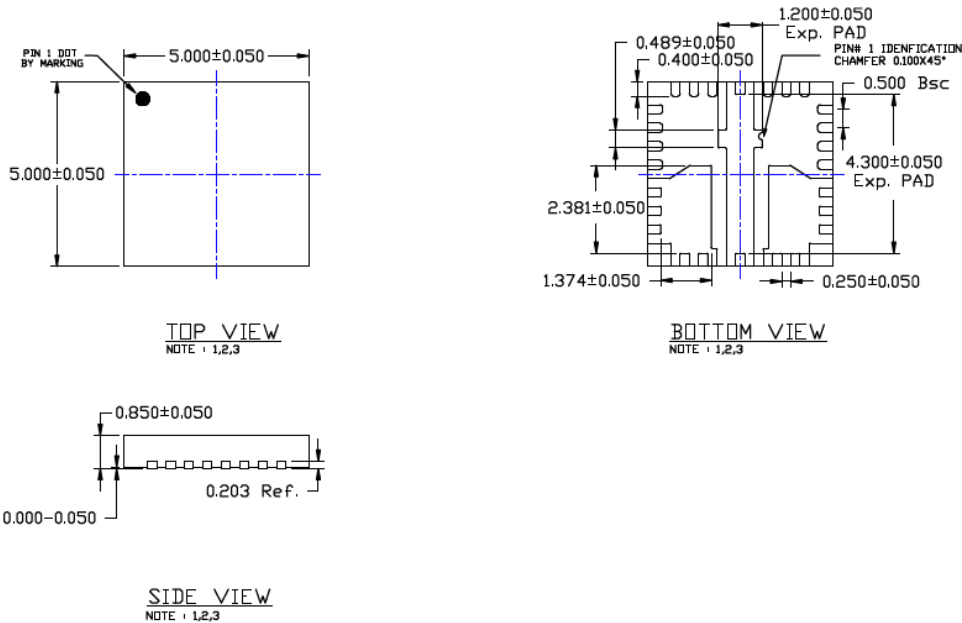
**NOTE :**

1. Max package warpage is 0.05mm.
2. Max allowable burr is 0.076mm in all directions.
3. Pin #1 will be laser marked.
4. Red circle in land pattern indicate thermal via. Size should be 0.30mm in diameter, 0.625mm pitch and should be connected to GND for max thermal performance.
5. Green rectangles (shaded area) in GND black colored pad represent stencil opening on exposed area. Size is 0.35x0.98mm, pitch is 1.18mm.
6. Dark Green shown in hidden lines (Optional) for improved thermal performance.
7. Blue & Magenta colored pads represent different potentials, do not connect to GND.
8. Green rectangles (shaded area) in blue & magenta colored pad represent stencil opening on exposed area. Size is 0.70x0.75mm, pitch is 0.95mm.

Note: For the most current package drawings, please see the Microchip Packaging Specification located at <http://www.microchip.com/packaging>.

**Package Outlines and Dimensions**

POD-Land Pattern drawing #FQFN55-32LD-PL-1

RECOMMENDED LAND PATTERN

NOTE : 4,5,6,7,8

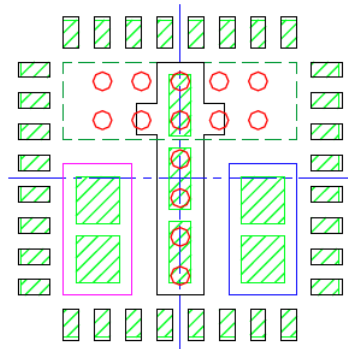

STACKED-UP

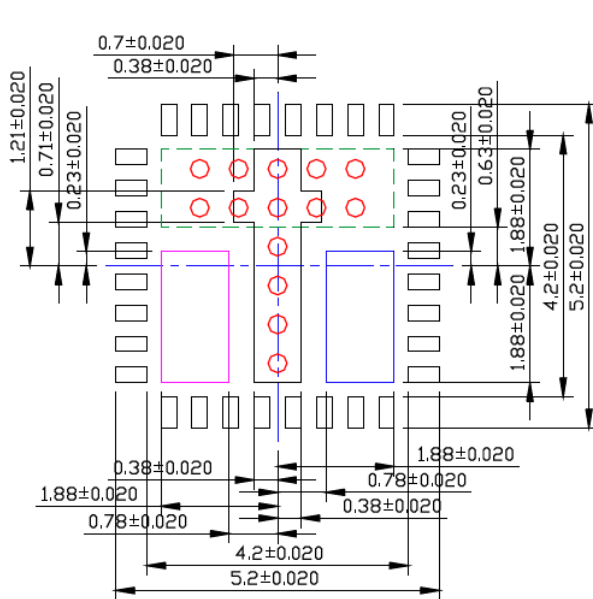

EXPOSED METAL TRACE

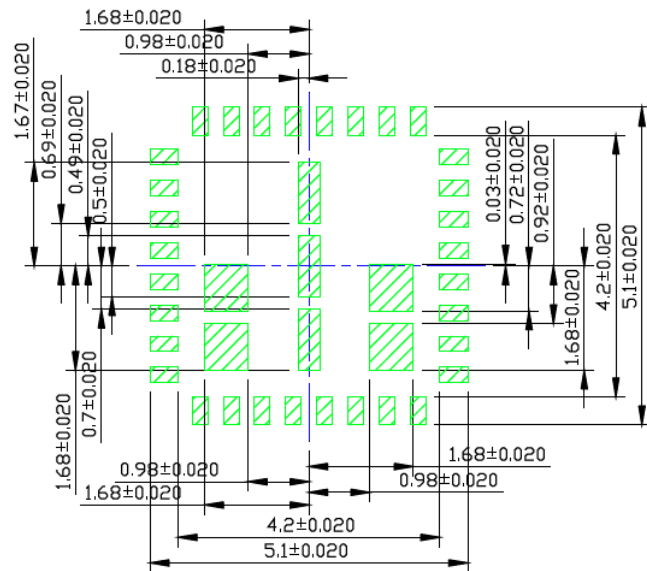

SOLDER STENCIL OPENING

Note: For the most current package drawings, please see the Microchip Packaging Specification located at <http://www.microchip.com/packaging>.



---



---

## Package Outlines and Dimensions

---



---

**TITLE**

34 LEAD FQFN 4x6mm PACKAGE (Flip Chip) OUTLINE &amp; RECOMMENDED LAND PATTERN

<b>DRAWING #</b>	FQFN46-34LD-PL-1	<b>UNIT</b>	MM
------------------	------------------	-------------	----

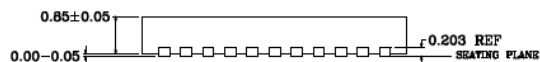
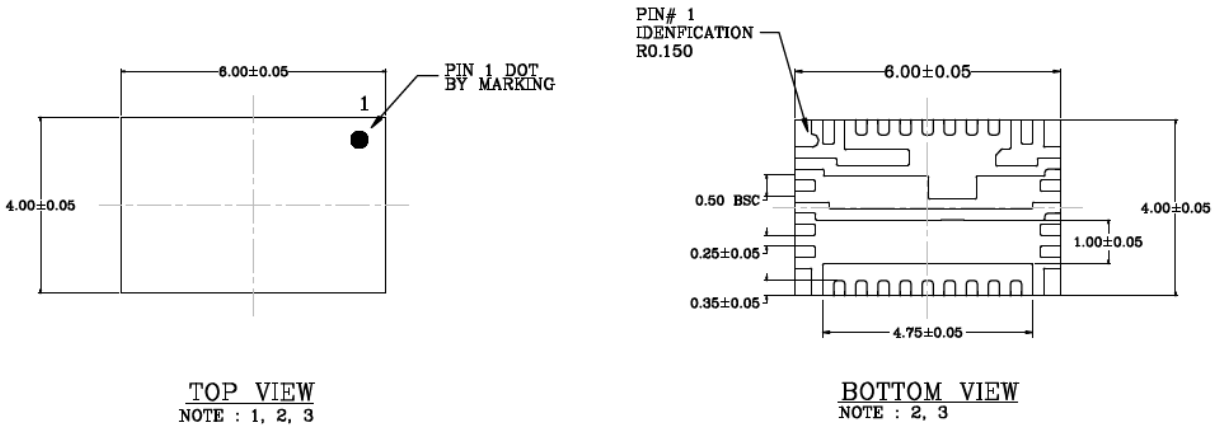

**SIDE VIEW**  
NOTE : 2, 3

**NOTES:**

1. Top mark Pin #1 will be laser mark.
2. 0.05mm max package warpage.
3. Max allowable burr is 0.076mm in all directions.
4. Red color circles are thermal via. 0.30-0.35mm in diameter and 0.80mm pitch and should be connected to GND for maximum performance.
5. Blue and Purple color pads represent different potential. Do not connect to GND.
6. Green rectangles (shaded area) represents solder stencil opening on exposed metal trace.
7. Recommended Land Pattern Tolerance is  $\pm 0.020$ mm unless specified.
8. See recommended land pattern on page2.

Note: For the most current package drawings, please see the Microchip Packaging Specification located at <http://www.microchip.com/packaging>.

**Package Outlines and Dimensions**

POD-Land Pattern Doc #: FQFN46-34LD-PL-1-A

**Recommended Land Pattern**

Note: 4,5,6,7

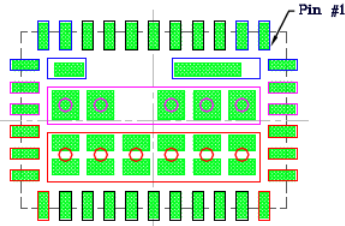

**Stack Up**

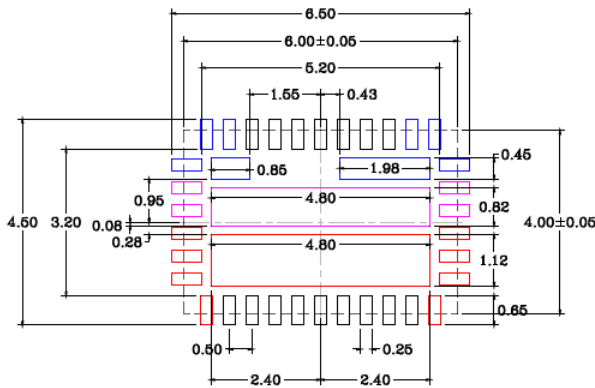

**Exposed Metal Trace**

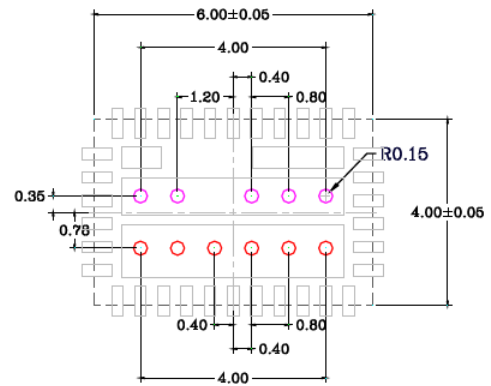

**Thermal (filled) Via**

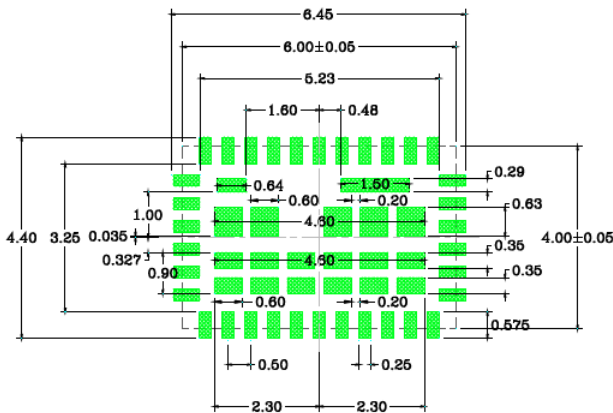

**Solder Stencil Opening**

Note: For the most current package drawings, please see the Microchip Packaging Specification located at <http://www.microchip.com/packaging>.

---



---

## Package Outlines and Dimensions

---



---

**TITLE**

34 LEAD FQFN 4x6mm PACKAGE (Flip Chip) OUTLINE &amp; RECOMMENDED LAND PATTERN

<b>DRAWING #</b>	FQFN46-34LD-PL-2	<b>UNIT</b>	MM
<b>Lead Frame</b>	Copper	<b>Lead Finish</b>	Matte Tin

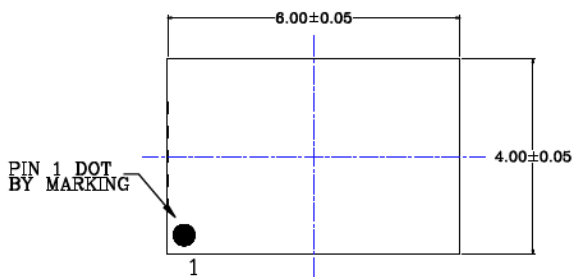

TOP VIEW  
NOTE : 1, 2, 3

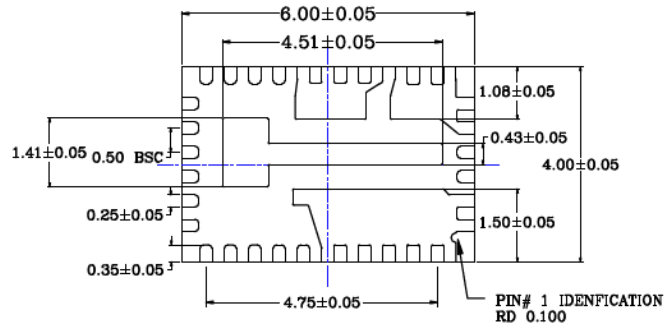

BOTTOM VIEW  
NOTE : 2, 3

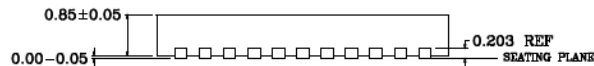

SIDE VIEW  
NOTE : 2, 3

**NOTES:**

1. Top mark Pin #1 will be laser mark.
2. 0.05mm max package warpage.
3. Max allowable burr is 0.076mm in all directions.
4. Black colored circles are thermal via. 0.30-0.35mm in diameter and 0.62mm pitch and should be connected to GND for maximum performance.
5. Green rectangles (shaded area) in GND Black colored pad represent stencil opening on exposed area. Size is 0.74x0.27mm, 0.94mm pitch.
6. Black colored hidden lines (optional) for improved thermal performance.
7. Blue and Red color pads represent different potential. Do not connect to GND.
8. Green rectangles (shaded area) in Red colored pad represents solder stencil opening on exposed area. Size is 0.57x0.35mm, 0.77mm pitch.
9. Recommended Land Pattern Tolerance is  $\pm 0.020$ mm unless specified.

Note: For the most current package drawings, please see the Microchip Packaging Specification located at <http://www.microchip.com/packaging>.

## Package Outlines and Dimensions

POD-Land Pattern drawing #FQFN46-34LD-PL-2

### RECOMMENDED LAND PATTERN

NOTE : 4, 5, 6, 7, 8, 9

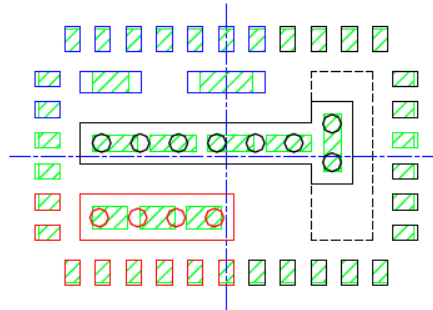

STACKED-UP

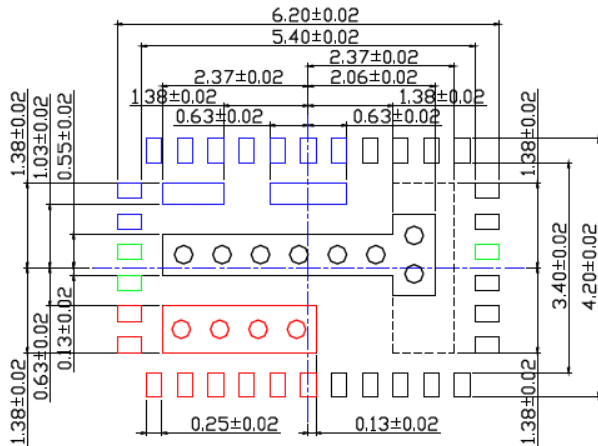

EXPOSED METAL TRACE

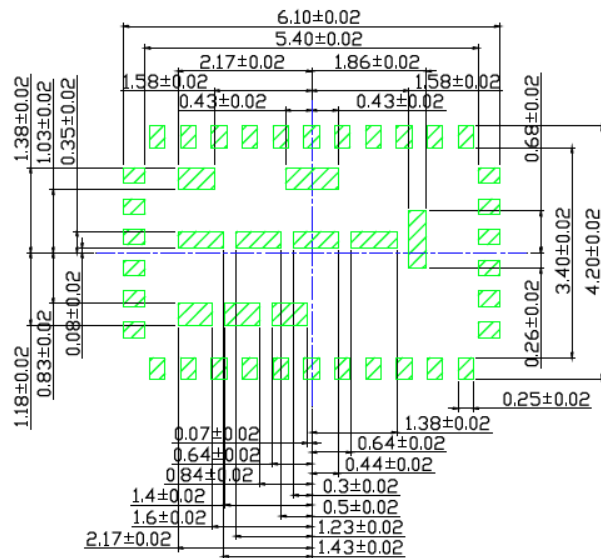

SOLDER STENCIL OPENING

Note: For the most current package drawings, please see the Microchip Packaging Specification located at <http://www.microchip.com/packaging>.

---



---

## Package Outlines and Dimensions

---



---

**TITLE**

36 LEAD QFN 4.5x4.5mm PACKAGE (Flip Chip) OUTLINE &amp; RECOMMENDED LAND PATTERN

<b>DRAWING #</b>	FQFN4545-36LD-PL-1	<b>UNIT</b>	MM
<b>Lead Frame</b>	Copper	<b>Lead Finish</b>	Matte Tin

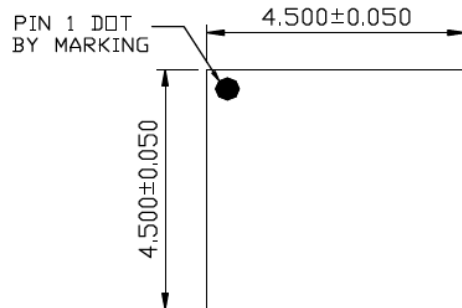

TOP VIEW  
NOTE 1, 2, 3

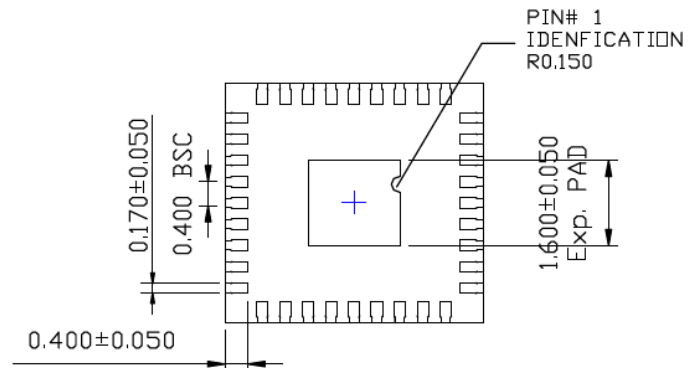

BOTTOM VIEW  
NOTE 1, 2, 3

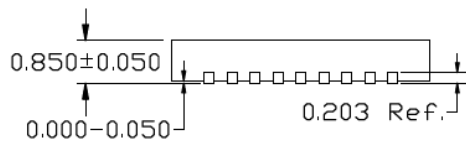

SIDE VIEW  
NOTE 1, 2, 3

**NOTE:**

1. MAX PACKAGE WARPAGE IS 0.05 MM
2. MAX ALLOWABLE BURR IS 0.076MM IN ALL DIRECTIONS
3. PIN #1 IS ON TOP WILL BE LASER MARKED
4. RED CIRCLE IN LAND PATTERN REPRESENT THERMAL VIA. SIZE SHOULD BE 0.30-0.35MM IN DIAMETER, 0.8MM PITCH & MUST BE CONNECTED TO GND FOR MAX THERMAL PERFORMANCE
5. GREEN RECTANGLES (SHADED AREA, OPTIONAL) REPRESENT SOLDER STENCIL OPENING ON EXPOSED PAD AREA. SIZE SHOULD BE 0.60X0.60 MM IN SIZE, 0.20MM SPACING.
6. LAND PATTERN OPENINGS MARKED BY "\*" (PINS#14, 32 & EPAD) ARE OF SAME GND AND SHOULD BE CONNECTED ON BOARD LEVEL FOR MAXIMUM THERMAL PERFORMANCE

Note: For the most current package drawings, please see the Microchip Packaging Specification located at <http://www.microchip.com/packaging>.

**Package Outlines and Dimensions**

POD-Land Pattern drawing #FQFN4545-36LD-PL-1

RECOMMENDED LAND PATTERN

NOTE: 4, 5, 6

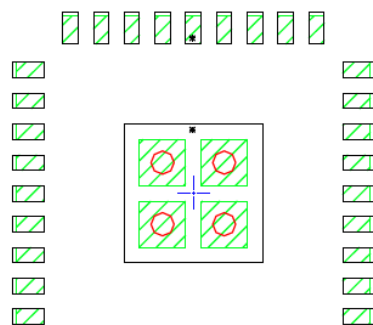

STACKED-UP

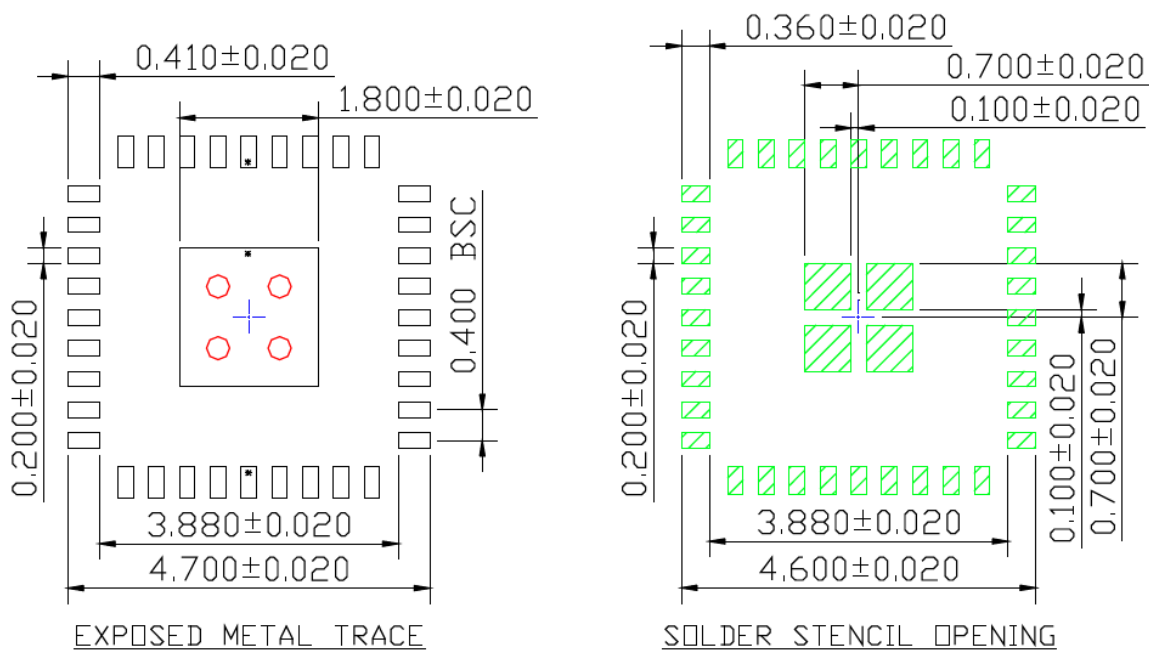

Note: For the most current package drawings, please see the Microchip Packaging Specification located at <http://www.microchip.com/packaging>.

---



---

## Package Outlines and Dimensions

---



---

**TITLE**

36 LEAD QFN 5x5mm PACKAGE (Flip Chip) OUTLINE &amp; RECOMMENDED LAND PATTERN

<b>DRAWING #</b>	FQFN55-36LD-PL-1	<b>UNIT</b>	MM
<b>Lead Frame</b>	NiPdAu	<b>Lead Finish</b>	NiPdAu

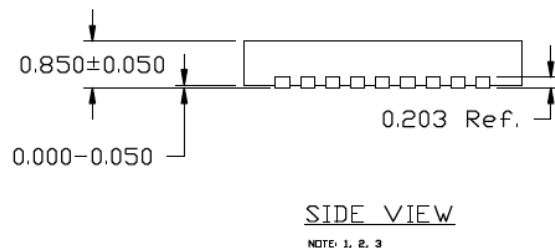
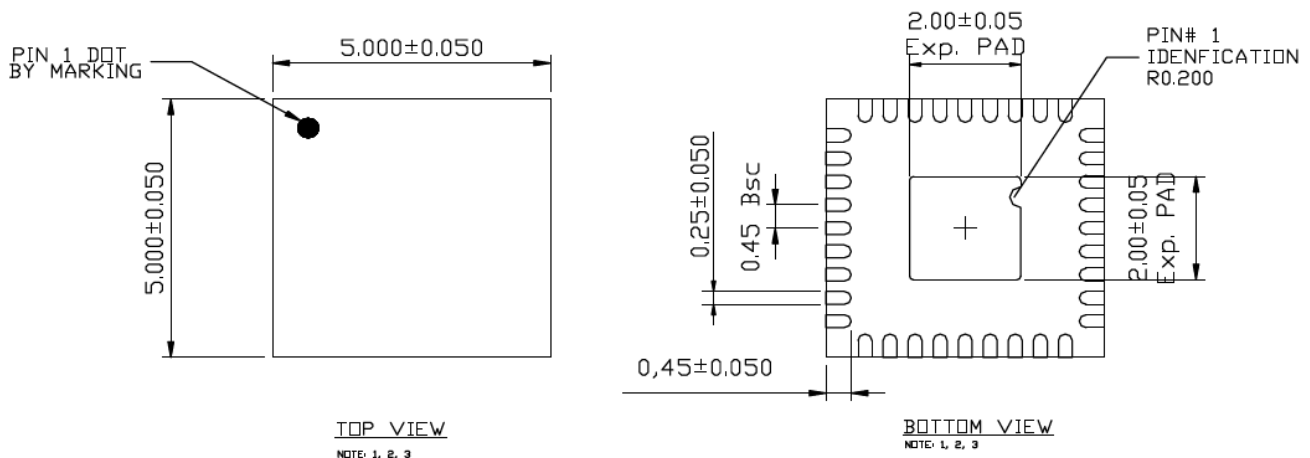
**NOTE:**

1. MAX PACKAGE WARPAGE IS 0.05 MM
2. MAX ALLOWABLE BURR IS 0.076 MM IN ALL DIRECTIONS
3. PIN #1 IS ON TOP WILL BE LASER MARKED
4. RED CIRCLE IN LAND PATTERN REPRESENT THERMAL VIA. SIZE SHOULD BE 0.30-0.35MM IN DIAMETER AND SHOULD BE CONNECTED TO GND FOR MAX THERMAL PERFORMANCE
5. GREEN RECTANGLES (SHADED AREA, OPTIONAL) REPRESENT SOLDER STENCIL OPENING ON EXPOSED PAD AREA. SIZE SHOULD BE 0.80X0.80 MM IN SIZE, 0.20 MM SPACING.
6. LAND PATTERN OPENINGS MARKED BY "\*" (PINS#14, 32 & EPAD) ARE OF SAME GND AND SHOULD BE CONNECTED ON BOARD LEVEL FOR MAXIMUM THERMAL PERFORMANCE

Note: For the most current package drawings, please see the Microchip Packaging Specification located at <http://www.microchip.com/packaging>.

**Package Outlines and Dimensions**

POD-Land Pattern drawing #FQFN55-36LD-PL-1

RECOMMENDED LAND PATTERN

NOTE: 4, 5, 6

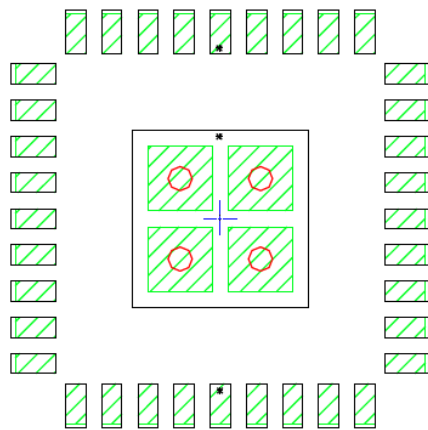

STACKED-UP

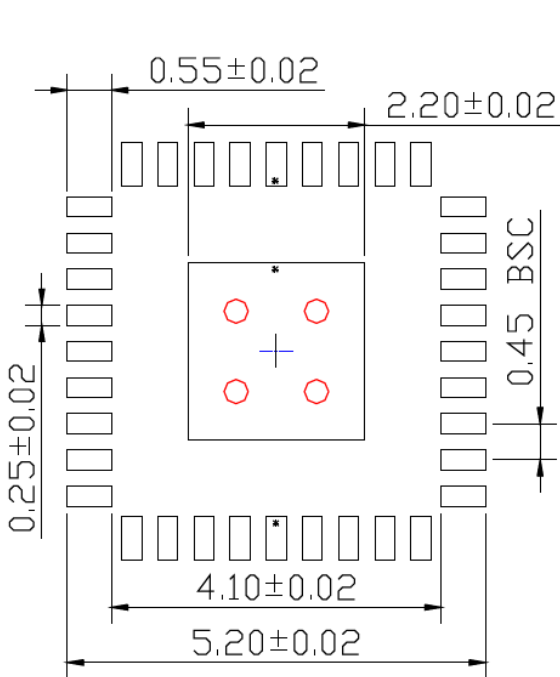

EXPOSED METAL TRACE

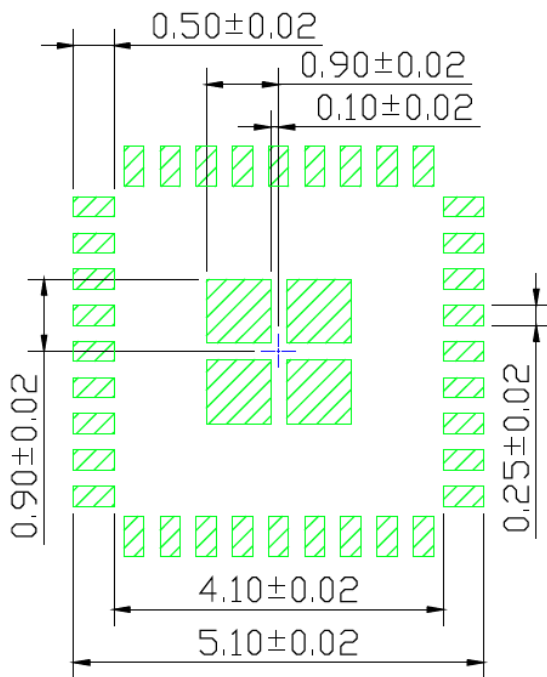

SOLDER STENCIL OPENING

Note: For the most current package drawings, please see the Microchip Packaging Specification located at <http://www.microchip.com/packaging>.



---



---

## Package Outlines and Dimensions

---



---

**TITLE**

38 LEAD FQFN 5x6mm PACKAGE (Flip Chip) OUTLINE &amp; RECOMMENDED LAND PATTERN

<b>DRAWING #</b>	FQFN56-38LD-PL-1	<b>UNIT</b>	MM
<b>Leadframe</b>	Copper	<b>Lead finish</b>	Matte Tin

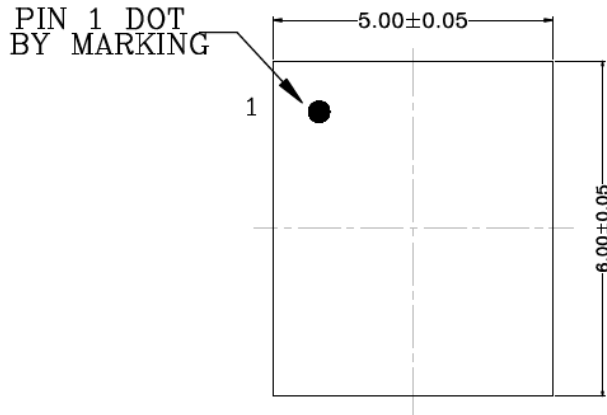

TOP VIEW

NOTE : 1, 2, 3

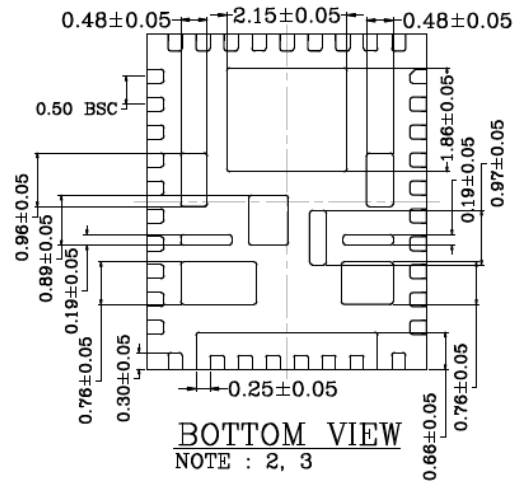

BOTTOM VIEW

NOTE : 2, 3

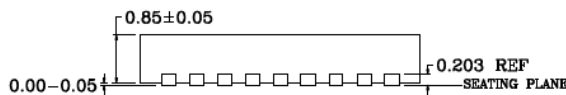

SIDE VIEW

NOTE : 2, 3

**NOTES:**

1. Top mark Pin #1 will be laser mark.
2. 0.05mm max package warpage.
3. Max allowable burr is 0.076mm in all directions.
4. Black color circles are thermal via. 0.30-0.35mm in diameter and 0.60mm pitch and should be connected to GND for maximum performance.
5. Blue and Red color pads & via holes represent different potential. Do not connect to GND.
6. Green rectangles (shaded area) represents solder stencil opening on exposed metal trace.
7. Recommended Land Pattern Tolerance is  $\pm 0.020$ mm unless specified.
8. See recommended land pattern on page 2 & 3.

Note: For the most current package drawings, please see the Microchip Packaging Specification located at <http://www.microchip.com/packaging>.

**Package Outlines and Dimensions**

POD-Land Pattern Doc #: FQFN56-38LD-PL-1

RECOMMENDED LAND PATTERN

NOTE : 4, 5, 6, 7, 8

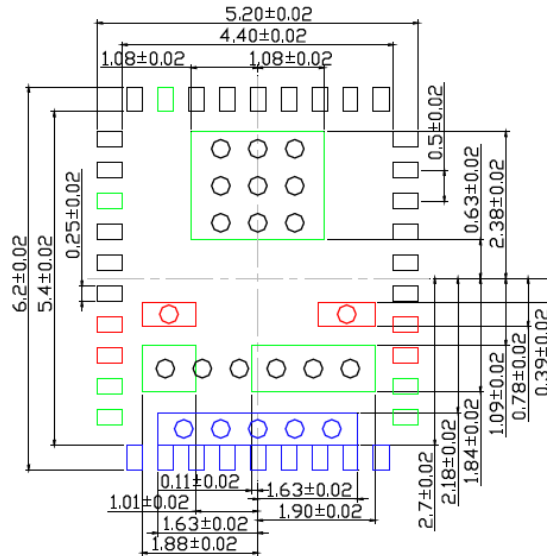

EXPOSED METAL TRACE

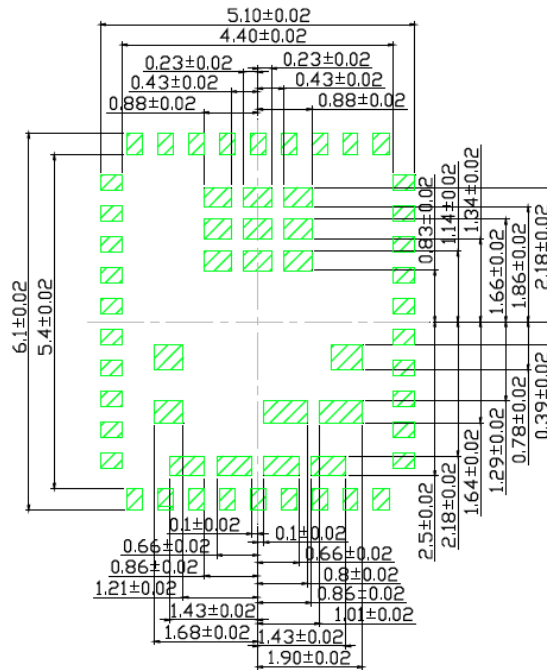

SOLDER STENCIL OPENING

Note: For the most current package drawings, please see the Microchip Packaging Specification located at <http://www.microchip.com/packaging>.

---

---

**Package Outlines and Dimensions**

---

---

POD-Land Pattern Doc #: FQFN56-38LD-PL-1

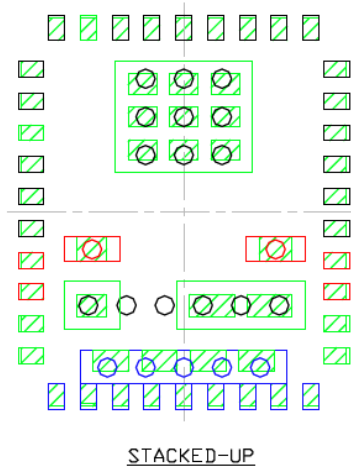

Note: For the most current package drawings, please see the Microchip Packaging Specification located at <http://www.microchip.com/packaging>.



**MICROCHIP**

---

---

**Package Outlines and Dimensions**

---

---

**NOTES:**

---

---

**Package Outlines and Dimensions**

---

---

**FTDFN**

Micrel Legacy

## Package Outlines and Dimensions

### TITLE

4 LEAD FTDFN 1.2x1.2 mm PACKAGE (Flip Chip) OUTLINE & RECOMMENDED LAND PATTERN

<b>DRAWING #</b>	FTDFN1212-4LD-PL-1	<b>UNIT</b>	MM
<b>LEAD FRAME</b>	NiPdAu	<b>LEAD FINISH</b>	NiPdAu

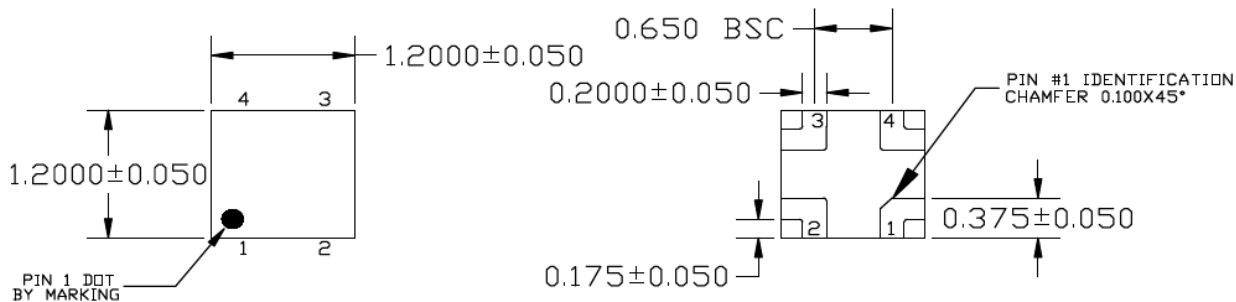

TOP VIEW

NOTE: 1, 2, 3

BOTTOM VIEW

NOTE: 1, 2

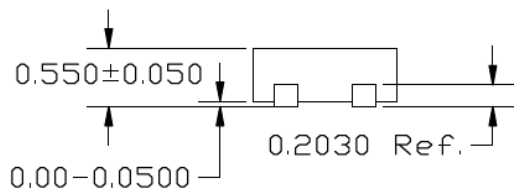

END VIEW

NOTE: 1, 2

### NOTE:

1. MAX PACKAGE WARPAGE IS 0.05 MM
2. MAX ALLOWABLE BURR IS 0.076MM IN ALL DIRECTIONS
3. PIN #1 IS ON TOP WILL BE LASER MARKED
4. GREEN COLORED SHADED RECTANGLES (AREA) REPRESENT SOLDER STENCIL OPENING ON EXPOSED METAL TRACE
5. CYAN COLORED SHADED AREAS REPRESENT OPTIONAL SOLDER STENCIL OPENING FOR IMPROVED THERMAL PERFORMANCE

Note: For the most current package drawings, please see the Microchip Packaging Specification located at <http://www.microchip.com/packageing>.

**Package Outlines and Dimensions**

POD-Land Pattern drawing #FTDFN1212-4LD-PL-1

RECOMMENDED LAND PATTERN

NOTE: 4, 5

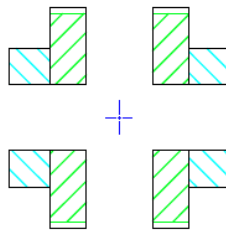

STACKED-UP

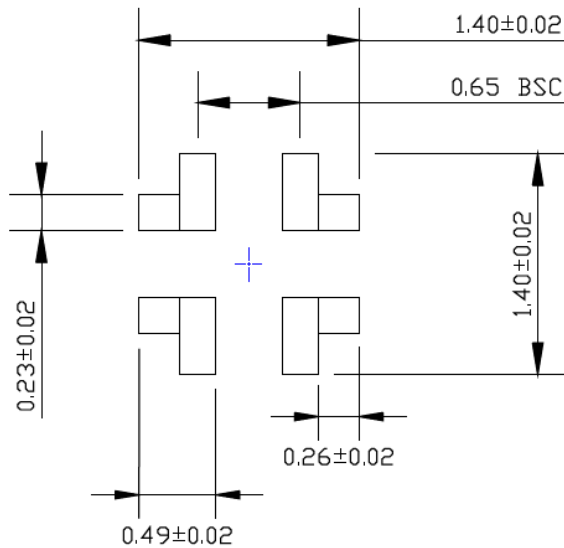

EXPOSED METAL TRACE

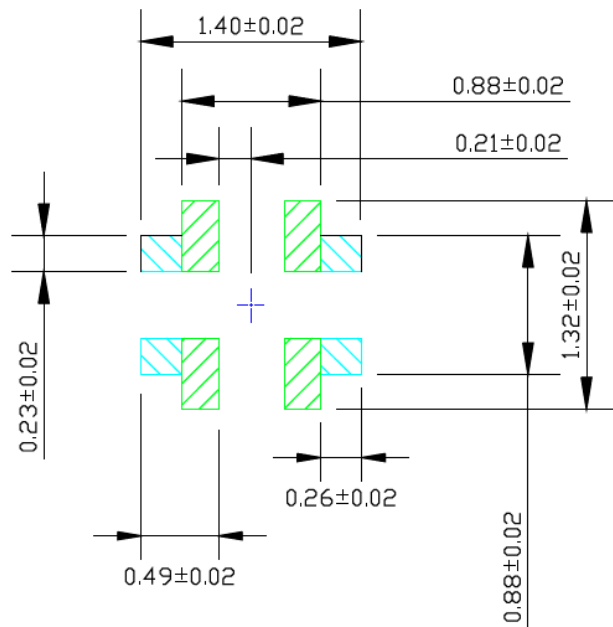

SOLDER STENCIL OPENING

Note: For the most current package drawings, please see the Microchip Packaging Specification located at <http://www.microchip.com/packaging>.

**Package Outlines and Dimensions**

**TITLE**

4 LEAD FTDFN 0.85x0.85 mm PACKAGE (Flip Chip) OUTLINE & RECOMMENDED LAND PATTERN

<b>DRAWING #</b>	FTDFN085085-4LD-PL-1	<b>UNIT</b>	MM
<b>LEAD FRAME</b>	Copper Alloy	<b>LEAD FINISH</b>	NiPdAu

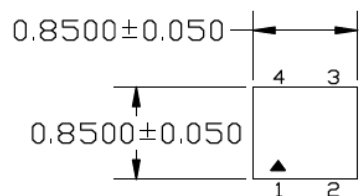

TOP VIEW  
NOTE: 1, 2, 3

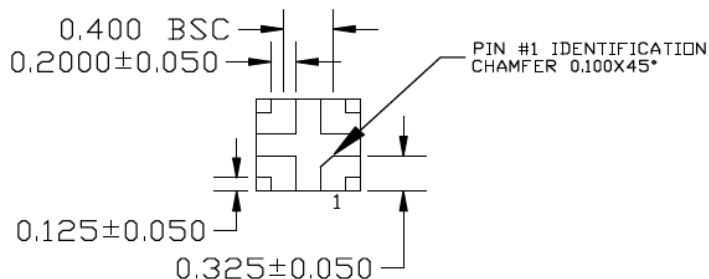

BOTTOM VIEW  
NOTE: 1, 2, 3

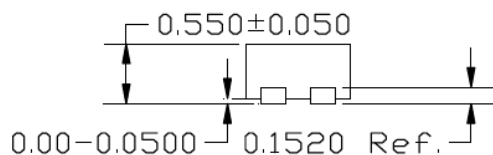

END VIEW  
NOTE: 1, 2, 3

**NOTE:**

1. MAX PACKAGE WARPAGE IS 0.05 MM
2. MAX ALLOWABLE BURR IS 0.076 MM IN ALL DIRECTIONS
3. PIN #1 IS ON TOP WILL BE LASER MARKED
4. GREEN COLORED RECTANGLES (SHADED AREA) REPRESENT SOLDER STENCIL OPENING ON EXPOSED METAL TRACE.
5. CYAN COLORED RECTANGLES (SHADED AREA) REPRESENT OPTIONAL SOLDER STENCIL OPENING.

Note: For the most current package drawings, please see the Microchip Packaging Specification located at <http://www.microchip.com/packaging>.



**Package Outlines and Dimensions**

POD-Land Pattern drawing #FTDFN085085-4LD-PL-1

RECOMMENDED LAND PATTERN

NOTE: 4, 5

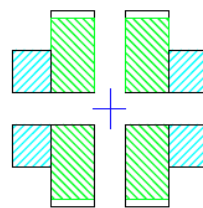

STACKED-UP

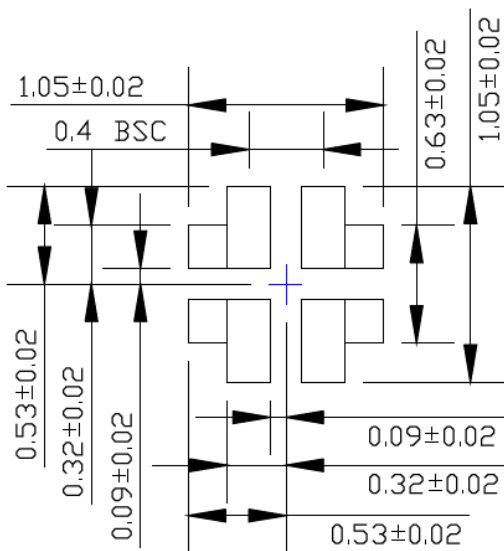

EXPOSED METAL TRACE

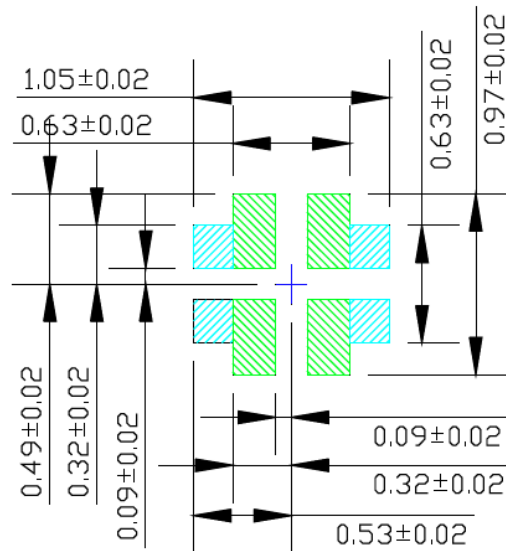

SOLDER STENCIL OPENING

Note: For the most current package drawings, please see the Microchip Packaging Specification located at <http://www.microchip.com/packaging>.

**Package Outlines and Dimensions**

**TITLE**

6 LEAD FTDFN 2.0x2.0 mm PACKAGE (Flip Chip) OUTLINE & RECOMMENDED LAND PATTERN

DRAWING #	FTDFN22-6LD-PL-1	UNIT	MM
-----------	------------------	------	----

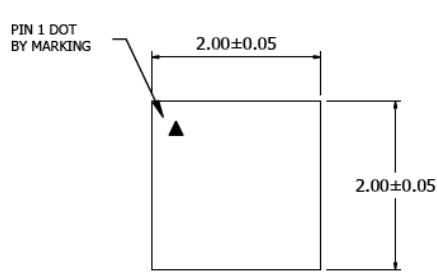

**Top View**

NOTE: 1,2,3

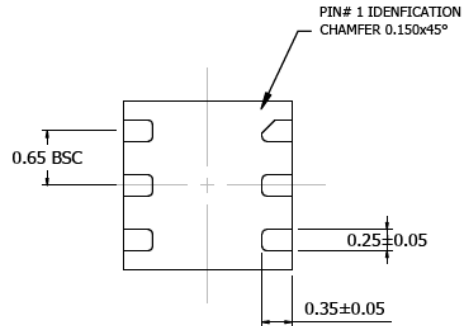

**Bottom View**

NOTE: 2,3

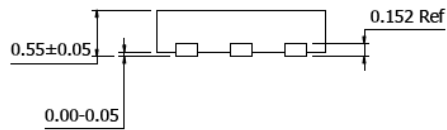

**Side View**

NOTE: 2,3

**NOTES:**

1. Top mark Pin #1 will be laser mark.
2. 0.05mm max package warpage.
3. Max allowable burr is 0.076mm in all directions.
4. Green, Blue and Red Color pads represent different potential. Do not connect to GND.
5. Black Color pads represent different IOs. Do not connect together.
6. Red Color circles are VIAs. 0.30-0.35mm in diameter and 0.80mm pitch. Should be connected to ground for maximum thermal performance.
7. Green Color shaded rectangles (area) represents solder stencil opening on exposed metal trace.
8. Recommended Land Pattern Tolerance is  $\pm 0.020$ mm unless specified.
9. See recommended Land Pattern on page2.

Note: For the most current package drawings, please see the Microchip Packaging Specification located at <http://www.microchip.com/packaging>.

---



---

## Package Outlines and Dimensions

---



---

POD-Land Pattern Doc #: FTDFN22-6LD-PL-1-Prem0

### Recommended Land Pattern

Note: 4,5,6,7

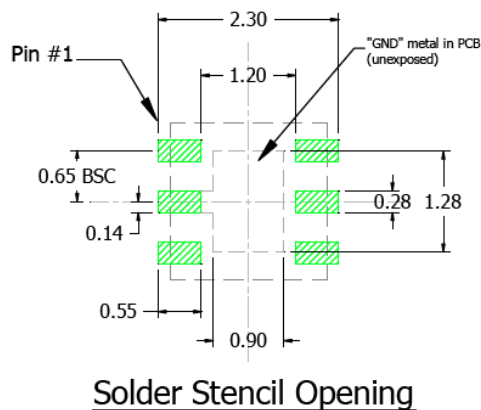
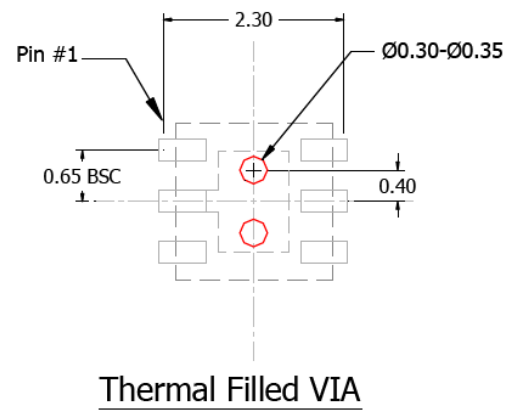
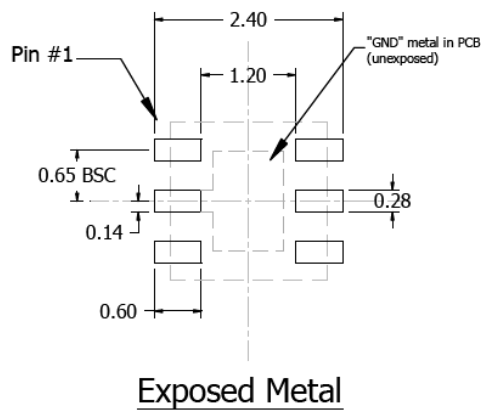
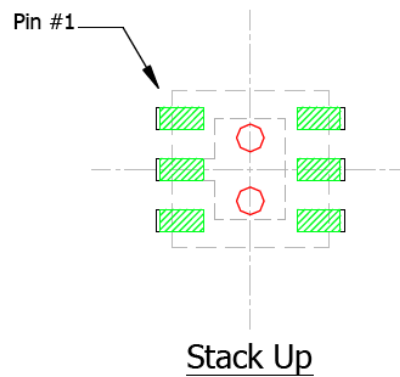

Note: For the most current package drawings, please see the Microchip Packaging Specification located at <http://www.microchip.com/packaging>.



**MICROCHIP**

---

---

**Package Outlines and Dimensions**

---

---

**NOTES:**

---

---

**Package Outlines and Dimensions**

---

---

**FTQFN**

Micrel Legacy

## Package Outlines and Dimensions

### TITLE

6 LEAD FTQFN 1.0 x1.0 mm PACKAGE (Flip Chip) OUTLINE & RECOMMENDED LAND PATTERN

<b>DRAWING #</b>	FTQFN1010-6LD-PL-1	<b>UNIT</b>	MM
<b>LEAD FRAME</b>	NiPdAu	<b>LEAD FINISH</b>	NiPdAu

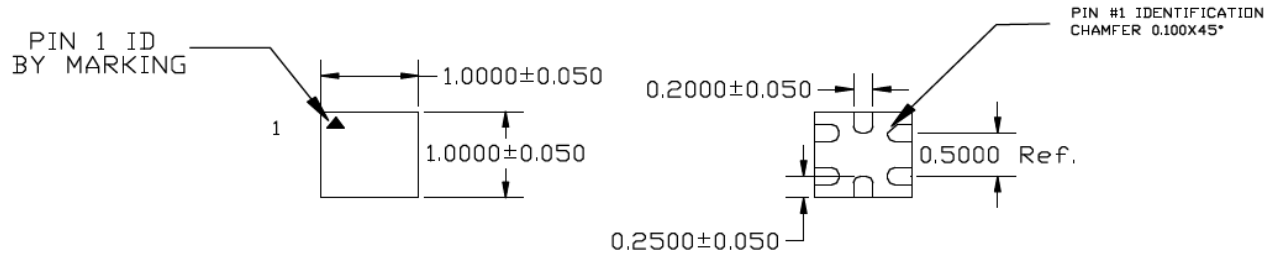

TOP VIEW  
NOTE: 1, 2, 3

BOTTOM VIEW  
NOTE: 1, 2, 3

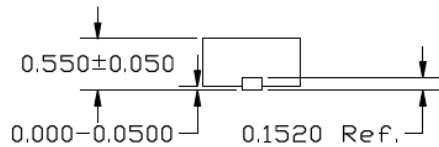

END VIEW  
NOTE: 1, 2, 3

### NOTE:

1. MAX PACKAGE WARPAGE IS 0.05 MM
2. MAX ALLOWABLE BURR IS 0.076MM IN ALL DIRECTIONS
3. PIN #1 IS ON TOP WILL BE LASER MARKED
4. GREEN RECTANGLES (SHADED AREA) REPRESENT SOLDER STENCIL OPENING ON EXPOSED METAL TRACE

Note: For the most current package drawings, please see the Microchip Packaging Specification located at <http://www.microchip.com/packaging>.

**Package Outlines and Dimensions**

POD-Land Pattern drawing #FTQFN1010-6LD-PL-1

RECOMMENDED LAND PATTERN

NOTE: 4

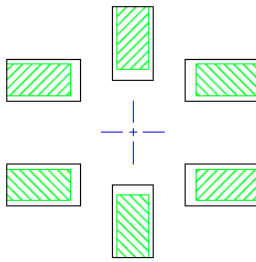

STACKED-UP

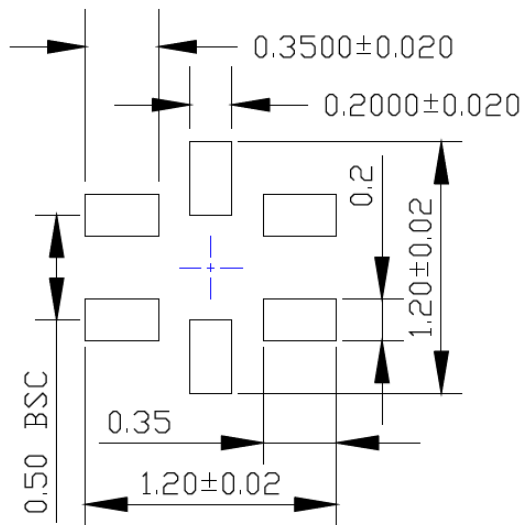

EXPOSED METAL TRACE

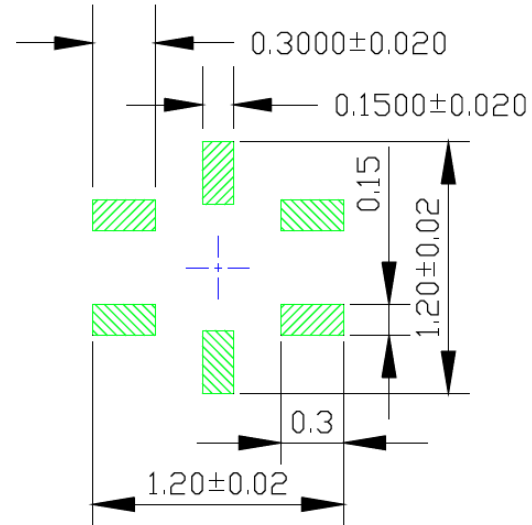

SOLDER STENCIL OPENING

Note: For the most current package drawings, please see the Microchip Packaging Specification located at <http://www.microchip.com/packaging>.

**Package Outlines and Dimensions**

**TITLE**

6 LEAD FTQFN 1.2x1.2 mm PACKAGE (Flip Chip) OUTLINE & RECOMMENDED LAND PATTERN

<b>DRAWING #</b>	FTQFN1212-6LD-PL-1	<b>UNIT</b>	MM
<b>LEAD FRAME</b>	NiPdAu	<b>LEAD FINISH</b>	NiPdAu

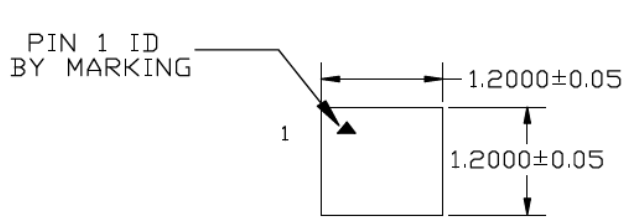

TOP VIEW  
NOTE: 1, 2, 3

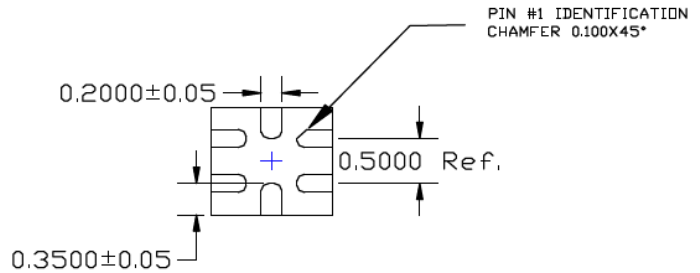

BOTTOM VIEW  
NOTE: 1, 2, 3

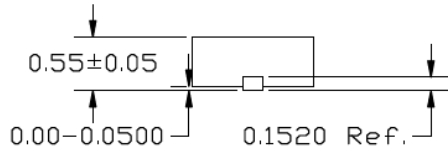

END VIEW  
NOTE: 1, 2, 3

**NOTE:**

1. MAX PACKAGE WARPAGE IS 0.05 MM
2. MAX ALLOWABLE BURR IS 0.076MM IN ALL DIRECTIONS
3. PIN #1 IS ON TOP WILL BE LASER MARKED
4. GREEN COLORED RECTANGLES (SHADED AREAS) INDICATE SOLDER STENCIL OPENING ON EXPOSED METAL TRACE

Note: For the most current package drawings, please see the Microchip Packaging Specification located at <http://www.microchip.com/packaging>.



---



---

**Package Outlines and Dimensions**

---



---

POD-Land Pattern drawing #FTQFN1212-6LD-PL-1

RECOMMENDED LAND PATTERN

NOTE : 4

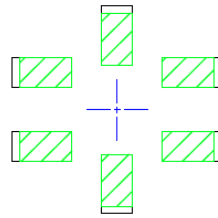

STACKED-UP

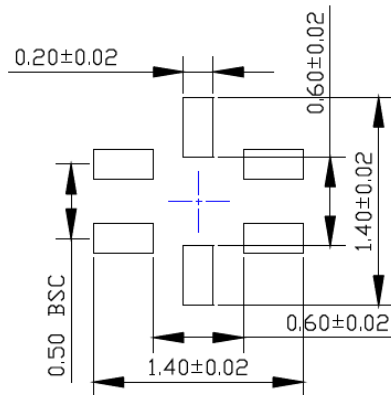

EXPOSED METAL TRACE

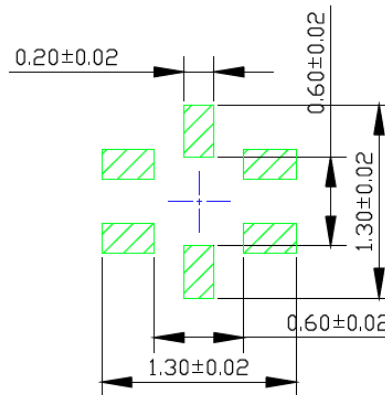

SOLDER STENCIL OPENING

Note: For the most current package drawings, please see the Microchip Packaging Specification located at <http://www.microchip.com/packaging>.

**Package Outlines and Dimensions**

**TITLE**

8 LEAD FTQFN 2.0x2.0 mm PACKAGE (Flip Chip) OUTLINE & RECOMMENDED LAND PATTERN

DRAWING #	FTQFN22-8LD-PL-1	UNIT	MM
-----------	------------------	------	----

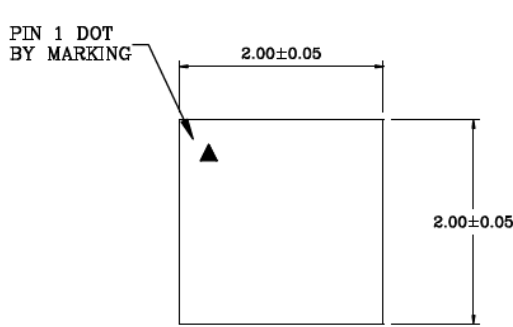

Top View

NOTE: 1,2,3

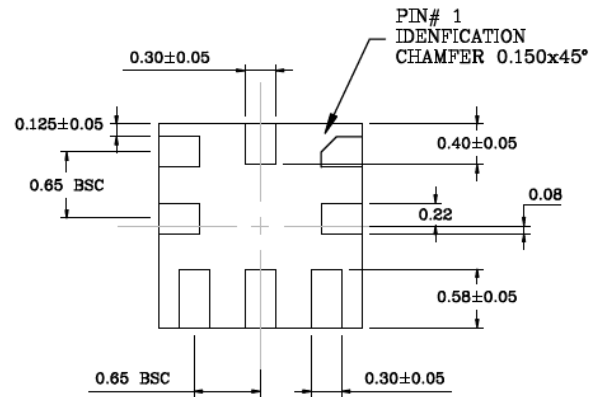

Bottom View

NOTE: 2,3

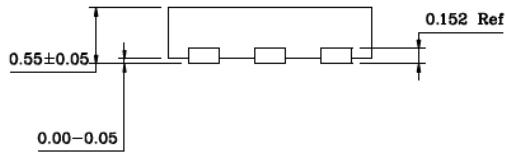

Side View

NOTE: 2,3

**NOTES:**

1. Top mark Pin #1 will be laser mark.
2. 0.05mm max package warpage.
3. Max allowable burr is 0.076mm in all directions.
4. Green, Blue and Red color pads represent different potential. Do not connect to GND.
5. Black color pads represent different IOs. Do not connect together.
6. Shaded rectangles (area) represents solder stencil opening on exposed metal trace.
7. Recommended Land Pattern Tolerance is  $\pm 0.020$ mm unless specified.
8. See recommended Land Pattern on page2.

Note: For the most current package drawings, please see the Microchip Packaging Specification located at <http://www.microchip.com/packaging>.

---



---

## Package Outlines and Dimensions

---



---

POD-Land Pattern Doc #: FTQFN22-8LD-PL-1-A

### Recommended Land Pattern

Note: 4.5.6.7

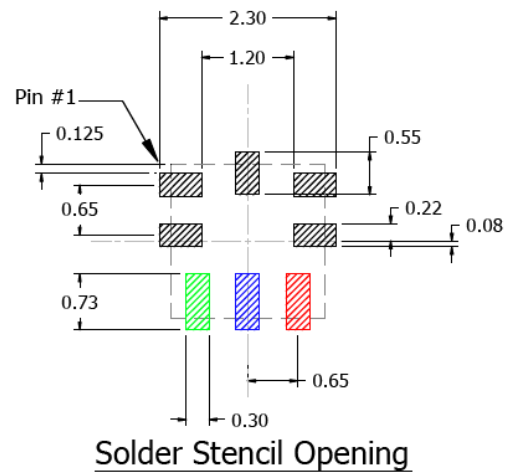
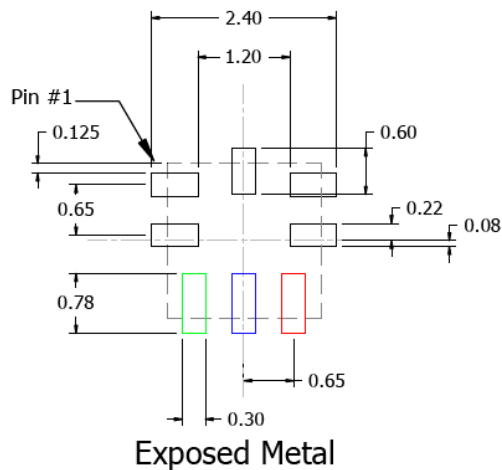
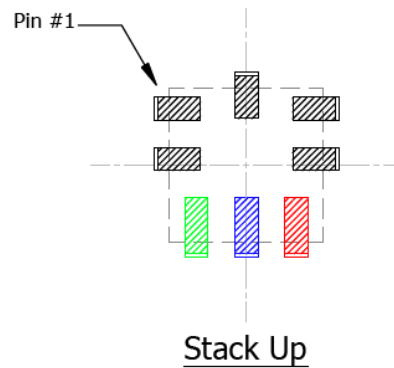

Note: For the most current package drawings, please see the Microchip Packaging Specification located at <http://www.microchip.com/packaging>.

## Package Outlines and Dimensions

### TITLE

12 LEAD FTQFN 2.0x2.0 mm PACKAGE (Flip Chip) OUTLINE & RECOMMENDED LAND PATTERN

<b>DRAWING #</b>	FTQFN22-12LD-PL-1	<b>UNIT</b>	MM
<b>LEAD FRAME</b>	Copper Alloy	<b>LEAD FINISH</b>	NiPdAu

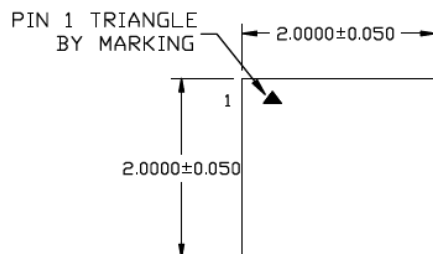

TOP VIEW  
NOTE: 1, 2, 3

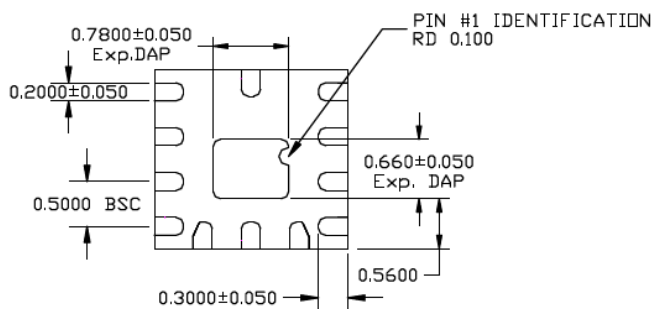

BOTTOM VIEW  
NOTE: 1, 2, 3

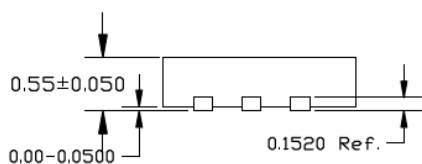

SIDE VIEW  
NOTE: 1, 2, 3

### NOTE:

1. MAX PACKAGE WARPAGE IS 0.05 MM
2. MAX ALLOWABLE BURR IS 0.076 MM IN ALL DIRECTIONS
3. PIN #1 IS ON TOP WILL BE LASER MARKED
4. GREEN COLORED RECTANGLES (SHADED AREA) REPRESENT SOLDER STENCIL OPENING ON EXPOSED METAL TRACE.
5. RED CIRCLE IN LAND PATTERN REPRESENT THERMAL VIA. RECOMMENDED SIZE IS 0.20 MM DIAMETER, 0.40 MM PITCH AND SHOULD BE CONNECTED TO GND FOR MAX THERMAL PERFORMANCE
6. PURPLE HIDDEN LINES ARE RECOMMENDED METAL TRACE/GND PLANES FOR IMPROVED THERMAL PERFORMANCE

Note: For the most current package drawings, please see the Microchip Packaging Specification located at <http://www.microchip.com/packaging>.

**Package Outlines and Dimensions**

PO-Land Pattern drawing #FTQFN22-12LD-PL-1

RECOMMENDED LAND PATTERN

NOTE: 4, 5, 6

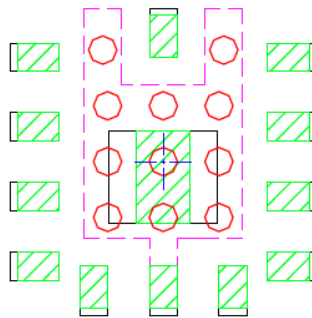

STACKED-UP

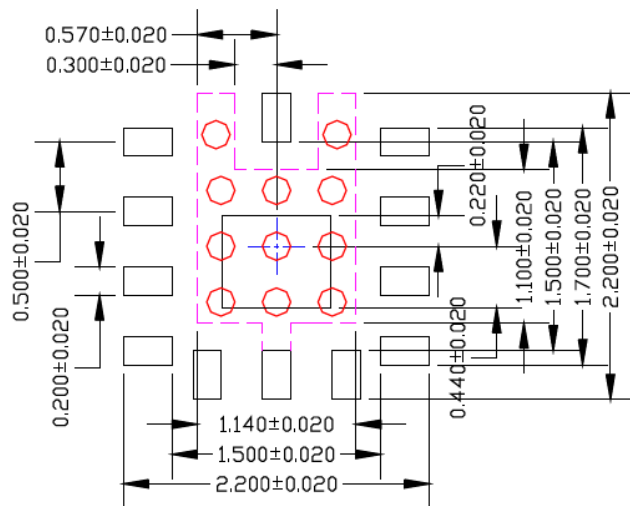

EXPOSED METAL TRACE

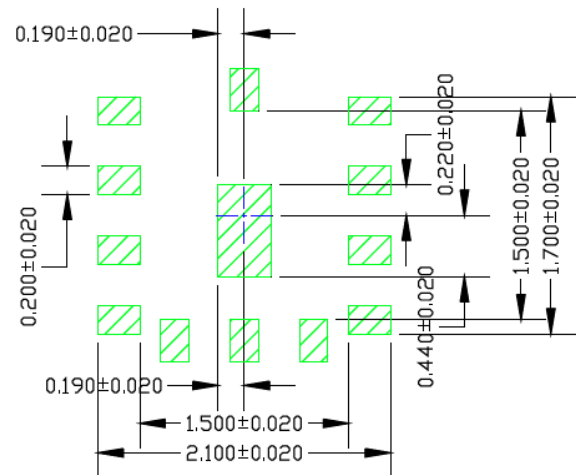

SOLDER STENCIL OPENING

Note: For the most current package drawings, please see the Microchip Packaging Specification located at <http://www.microchip.com/packaging>.

**Package Outlines and Dimensions**

**TITLE**

12 LEAD FTQFN 1.6x2.0 mm PACKAGE (Flip Chip) OUTLINE & RECOMMENDED LAND PATTERN

<b>DRAWING #</b>	FTQFN1620-12LD-PL-1	<b>UNIT</b>	MM
<b>LEAD FRAME</b>	NiPdAu	<b>LEAD FINISH</b>	NiPdAu

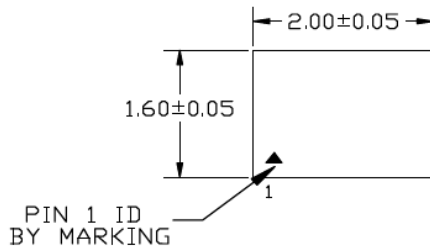

TOP VIEW  
NOTE: 1, 2, 3

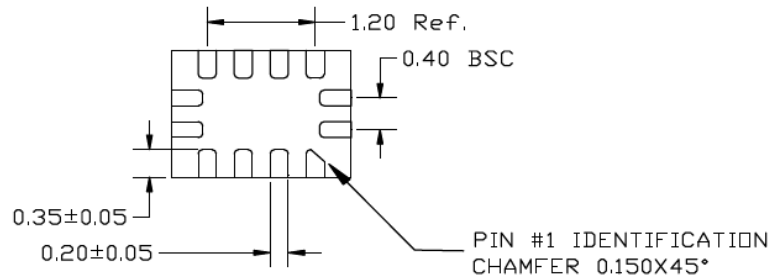

BOTTOM VIEW  
NOTE: 1, 2, 3

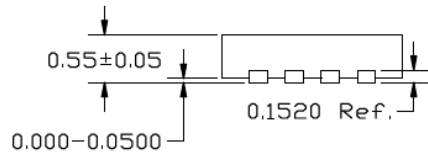

END VIEW  
NOTE: 1, 2, 3

**NOTE:**

1. MAX PACKAGE WARPAGE IS 0.05 MM
2. MAX ALLOWABLE BURR IS 0.076MM IN ALL DIRECTIONS
3. PIN #1 IS ON TOP WILL BE LASER MARKED
4. GREEN COLORED RECTANGLES (SHADED AREA) INDICATE SOLDER STENCIL OPENING ON EXPOSED METAL TRACE

Note: For the most current package drawings, please see the Microchip Packaging Specification located at <http://www.microchip.com/packaging>.

**Package Outlines and Dimensions**

POD-Land Pattern drawing #FTQFN1620-12LD-PL-1

RECOMMENDED LAND PATTERN

NOTE: 4

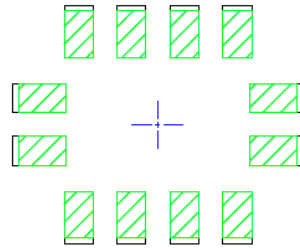

STACKED-UP

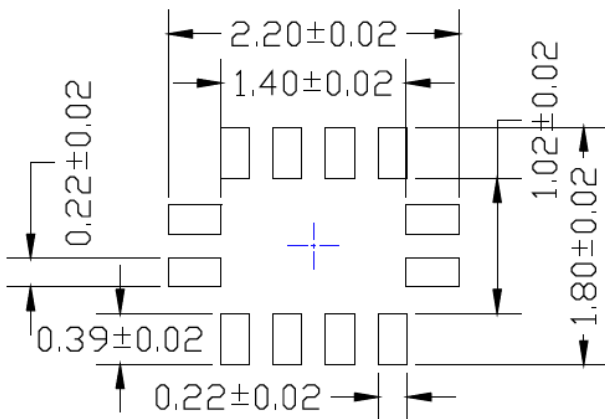

EXPOSED METAL TRACE

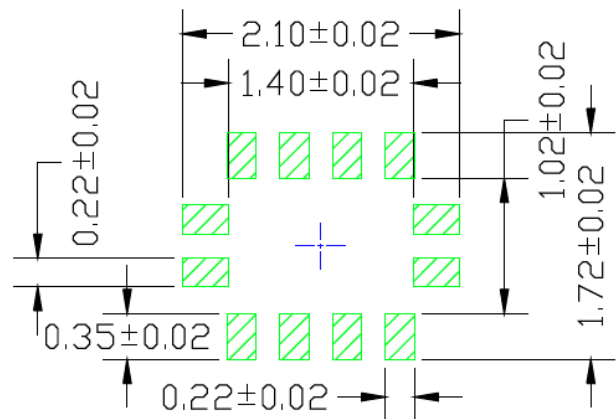

SOLDER STENCIL OPENING

Note: For the most current package drawings, please see the Microchip Packaging Specification located at <http://www.microchip.com/packaging>.

**Package Outlines and Dimensions**

**TITLE**

14 LEAD FTQFN 2.5x2.5mm PACKAGE OUTLINE & RECOMMENDED LAND PATTERN

DRAWING #	FTQFN2525-14LD-PL-1	UNIT	MM
-----------	---------------------	------	----

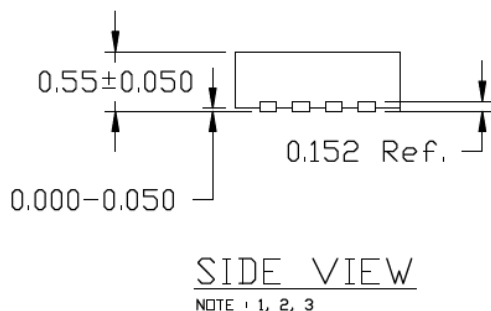
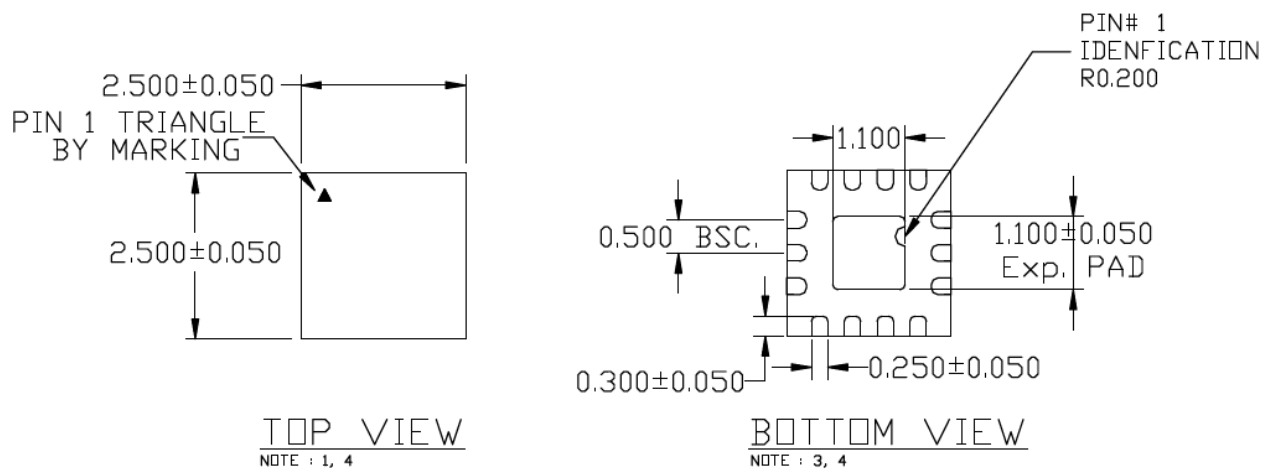

**NOTE:**

1. ALL DIMENSIONS ARE IN MILLIMETERS.
2. MAX. PACKAGE WARPAGE IS 0.08 mm.
3. MAXIMUM ALLOWABLE BURRS IS 0.076 mm IN ALL DIRECTIONS.
4. PIN #1 ID WILL BE LASER MARKED.
5. RED CIRCLE INDICATE THERMAL VIA. SIZE IS 0.300-0.350 mm IN DIAMETER AND SHOULD BE CONNECTED TO GND PLANE FOR MAXIMUM THERMAL PERFORMANCE.

Note: For the most current package drawings, please see the Microchip Packaging Specification located at <http://www.microchip.com/packaging>.



**Package Outlines and Dimensions**

RECOMMENDED LAND PATTERN

NOTE : 5

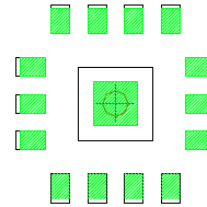

STACKED-UP

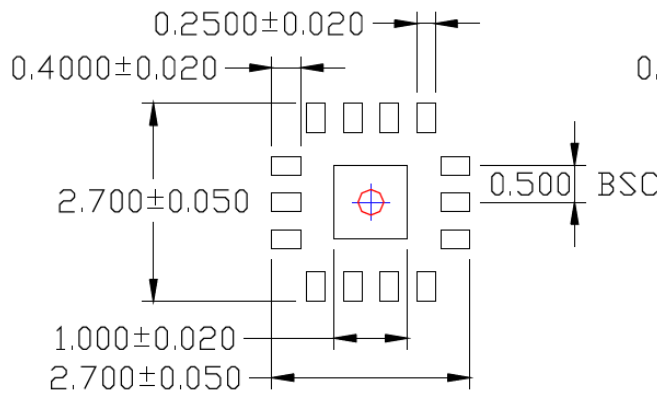

EXPOSED METAL TRACE

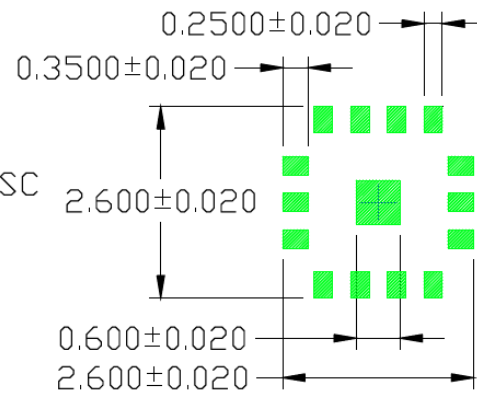

SOLDER STENCIL OPENING

Note: For the most current package drawings, please see the Microchip Packaging Specification located at <http://www.microchip.com/packaging>.

**Package Outlines and Dimensions**

**TITLE**

16 LEAD FTQFN 2X2mm PACKAGE (Flip Chip) OUTLINE & RECOMMENDED LAND PATTERN

<b>DRAWING #</b>	FTQFN22-16LD-PL-1	<b>UNIT</b>	MM
<b>Lead Frame</b>	NiPdAu	<b>Lead Finish</b>	NiPdAu

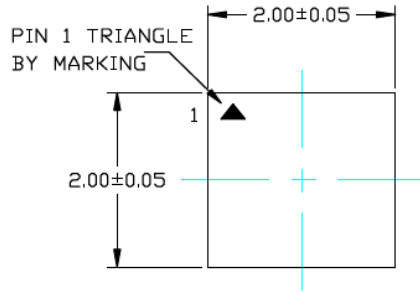

TOP VIEW  
NOTE: 1, 2, 3, 4

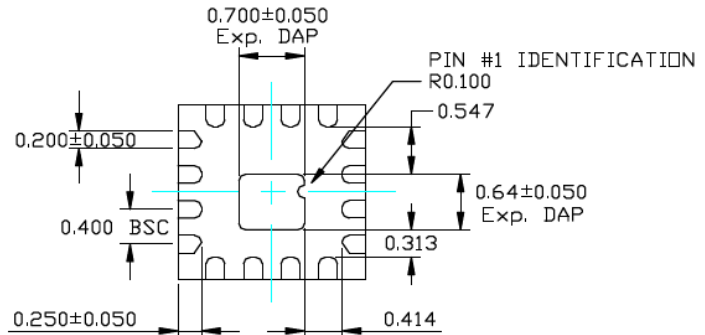

BOTTOM VIEW  
NOTE: 1, 2, 3, 4

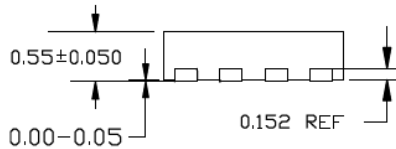

SIDE VIEW  
NOTE: 1, 2, 3, 4

**NOTE:**

1. ALL DIMENSION ARE IN MILLIMETERS
2. MAX PACKAGE WARPAGE IS 0.08 MM
3. MAX ALLOWABLE BURR IS 0.076 MM IN ALL DIRECTIONS
4. PIN #1 ID WILL BE LASER MARKED
5. RED CIRCLE INDICATES THERMAL VIA. SIZE SHOULD BE 0.300 MM IN DIAMETER AND SHOULD BE CONNECTED TO GROUND PLANE FOR MAXIMUM THERMAL PERFORMANCE.
6. GREEN COLORED RECTANGLES (SHADED AREA) REPRESENT SOLDER STENCIL OPENING ON EXPOSED METAL TRACE.

Note: For the most current package drawings, please see the Microchip Packaging Specification located at <http://www.microchip.com/packaging>.

**Package Outlines and Dimensions**

POD-Land Pattern drawing # FTQFN22-16LD-PL-1

RECOMMENDED LAND PATTERN

NOTE: 5

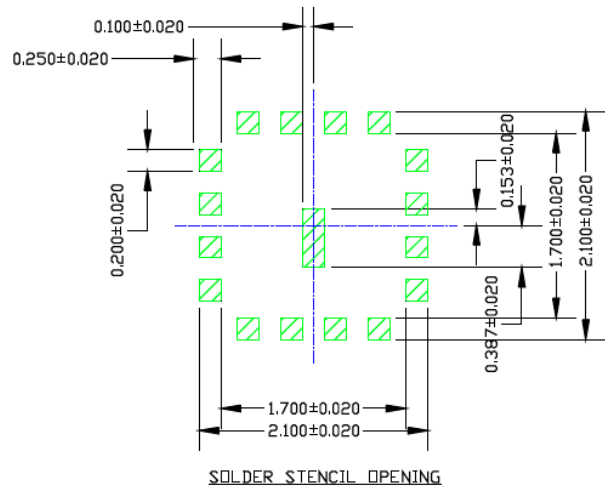
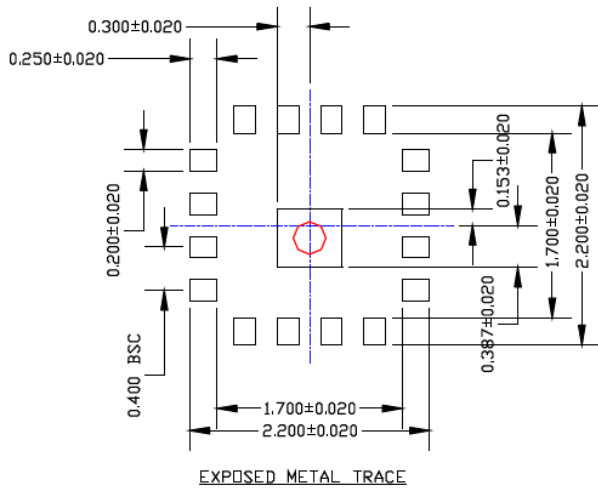
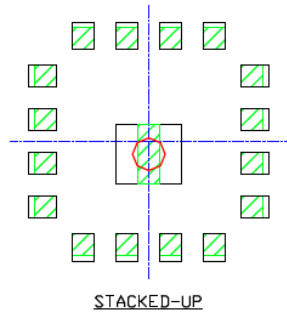

Note: For the most current package drawings, please see the Microchip Packaging Specification located at <http://www.microchip.com/packaging>.

## Package Outlines and Dimensions

### TITLE

16 LEAD FTQFN 2.0 x 2.5 mm PACKAGE (Flip Chip) OUTLINE & RECOMMENDED LAND PATTERN

<b>DRAWING #</b>	FTQFN2025-16LD-PL-1	<b>UNIT</b>	MM
<b>LEAD FRAME</b>	NiPdAu	<b>LEAD FINISH</b>	NiPdAu

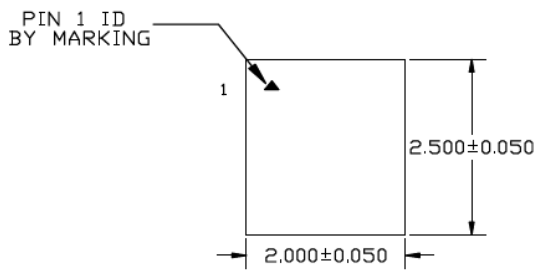

TOP VIEW  
NOTE: 1, 2, 3

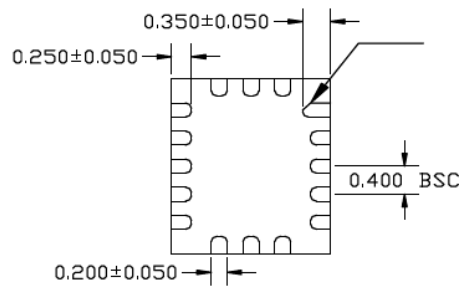

BOTTOM VIEW  
NOTE: 1, 2, 3

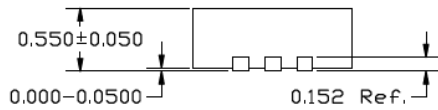

END VIEW  
NOTE: 1, 2, 3

### NOTE:

1. MAX PACKAGE WARPAGE IS 0.05 MM
2. MAX ALLOWABLE BURR IS 0.076MM IN ALL DIRECTIONS
3. PIN #1 IS ON TOP WILL BE LASER MARKED
4. GREEN COLORED RECTANGLES (SHADED AREAS) INDICATE SOLDER STENCIL OPENING ON EXPOSED METAL TRACE

Note: For the most current package drawings, please see the Microchip Packaging Specification located at <http://www.microchip.com/packaging>.

**Package Outlines and Dimensions**

POD-Land Pattern drawing #FTQFN2025-1 6LD-PL-1

RECOMMENDED LAND PATTERN

NOTE: 4

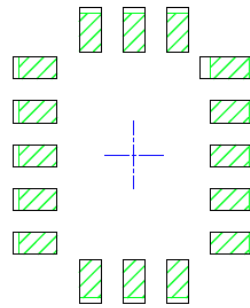

STACKED-UP

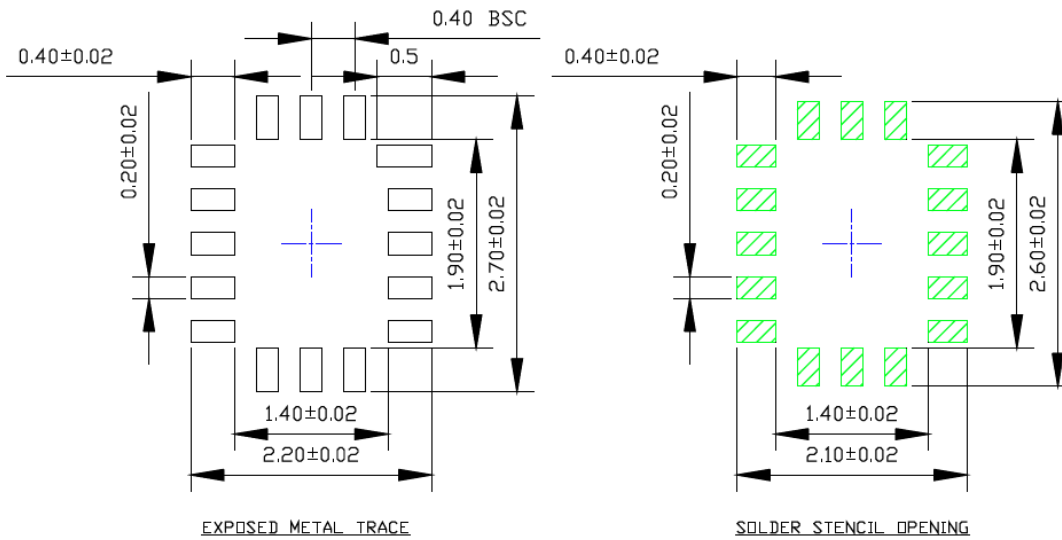

Note: For the most current package drawings, please see the Microchip Packaging Specification located at <http://www.microchip.com/packaging>.

**Package Outlines and Dimensions**

**TITLE**

16 LEAD FTQFN 2.5x2.5 mm PACKAGE (Flip Chip) OUTLINE & RECOMMENDED LAND PATTERN

<b>DRAWING #</b>	FTQFN2525-16LD-PL-1	<b>UNIT</b>	MM
------------------	---------------------	-------------	----

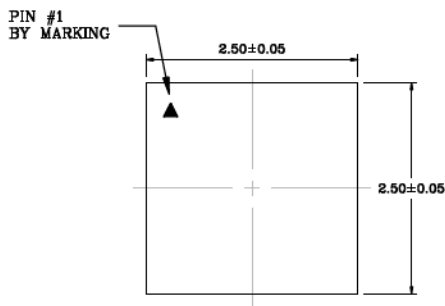

Top View

NOTE: 1,2,3

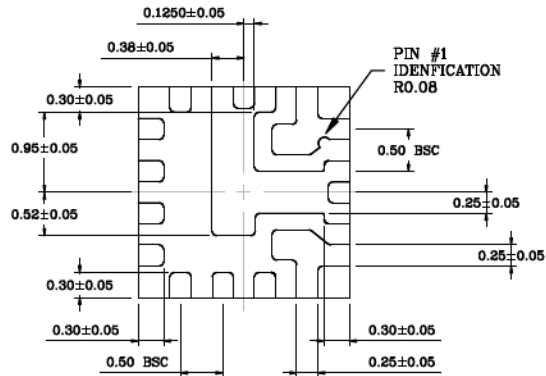

Bottom View

NOTE: 2,3

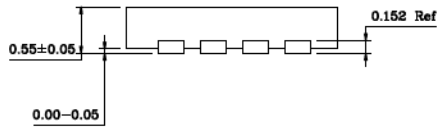

Side View

NOTE: 2,3

**NOTES:**

1. Top mark Pin #1 will be laser mark.
2. 0.05mm max package warpage.
3. Max allowable burr is 0.076mm in all directions.
4. Black, Blue and Red color pads represent different potential. Do not connect to GND.
5. Black color pads represent different IOs. Do not connect together.
6. Shaded rectangles (area) represents solder stencil opening on exposed metal trace.
7. Red Color circles are VIAs. 0.30mm diameter. Should be connected to ground for maximum thermal performance.
8. Thermal VIAs are optional.
9. Recommended Land Pattern Tolerance is  $\pm 0.020$ mm unless specified.
10. See recommended Land Pattern on page2.

Note: For the most current package drawings, please see the Microchip Packaging Specification located at <http://www.microchip.com/packaging>.

**Package Outlines and Dimensions**

POD-Land Pattern Doc #: FTQFN2525-16LD-PL-1-A

**Recommended Land Pattern**

Note: 4.5.6.7.8.9

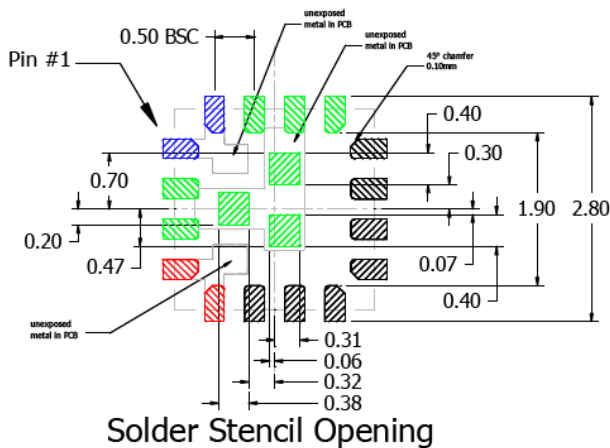
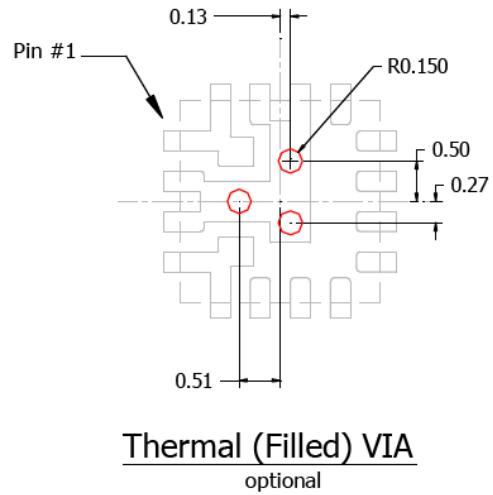
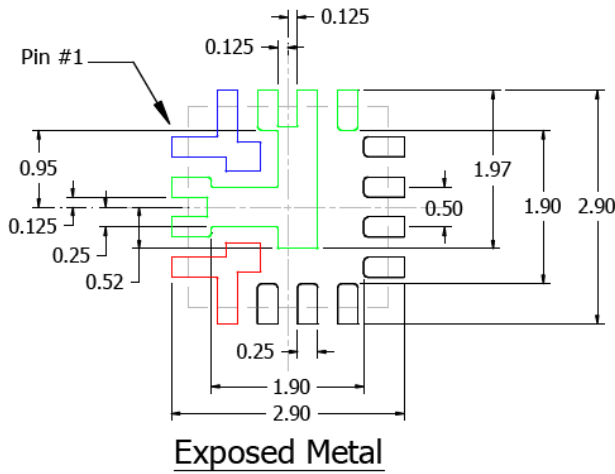
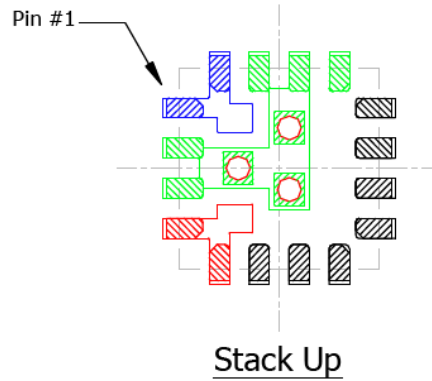

Note: For the most current package drawings, please see the Microchip Packaging Specification located at <http://www.microchip.com/packaging>.

## Package Outlines and Dimensions

### TITLE

20 LEAD FTQFN 3x3mm (Flip Chip) PACKAGE OUTLINE & RECOMMENDED LAND PATTERN

<b>DRAWING #</b>	FTQFN33-20LD-PL-1	<b>UNIT</b>	mm
<b>Lead Frame</b>	Copper	<b>Lead Finish</b>	Matte Tin

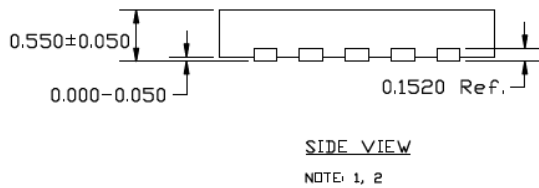
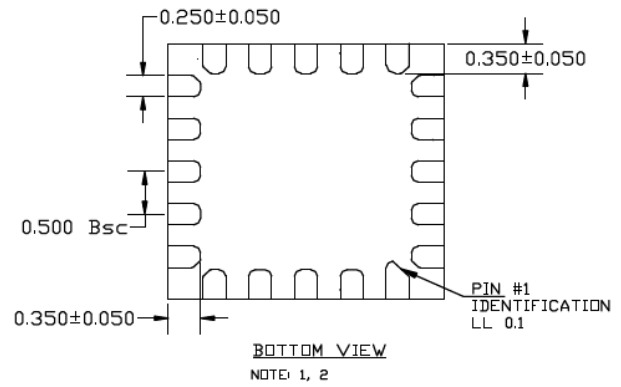
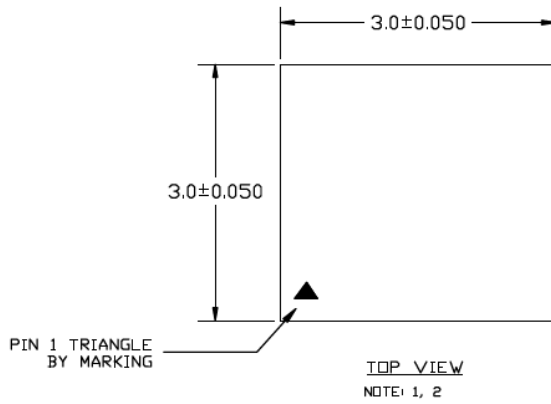

**NOTE:**

1. MAX PACKAGE WARPAGE IS 0.05 MM
2. MAX ALLOWABLE BURR IS 0.076 MM IN ALL DIRECTIONS
3. GREEN RECTANGLES (SHADED AREA) REPRESENT STENCIL OPENING ON EXPOSED METAL TRACE.

Note: For the most current package drawings, please see the Microchip Packaging Specification located at <http://www.microchip.com/packaging>.



**Package Outlines and Dimensions**

POD-Land Pattern drawing #FTQFN33-20LD-PL-1

**RECOMMENDED LAND PATTERN**

NOTE 1 3

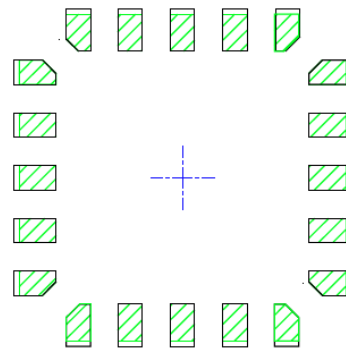

STACKED-UP

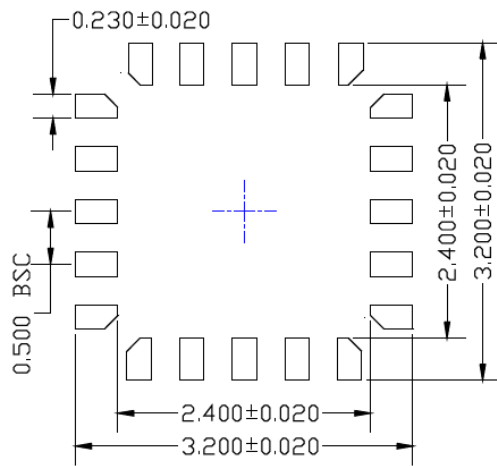

EXPOSED METAL TRACE

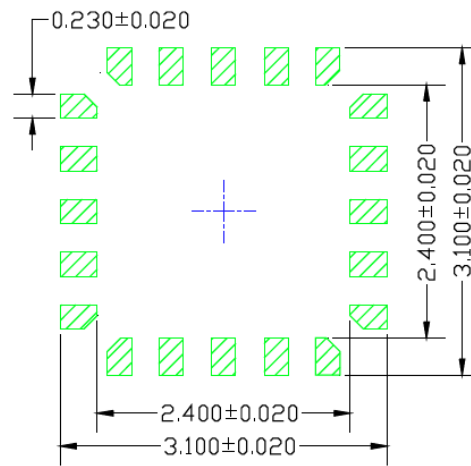

SOLDER STENCIL OPENING

Note: For the most current package drawings, please see the Microchip Packaging Specification located at <http://www.microchip.com/packaging>.



**MICROCHIP**

---

---

**Package Outlines and Dimensions**

---

---

**NOTES:**

---

---

**Package Outlines and Dimensions**

---

---

**GJQFN**

Micrel Legacy

## Package Outlines and Dimensions

### TITLE

20 LEAD GJQFN 2.5x3mm PKG (Flip Chip & Hybrid) OUTLINE & RECOMMENDED LAND PATTERN

<b>DRAWING #</b>	GJQFN2530-20LD-PL-1	<b>UNIT</b>	MM
<b>Lead Frame</b>	Copper	<b>Lead Finish</b>	Matte Tin

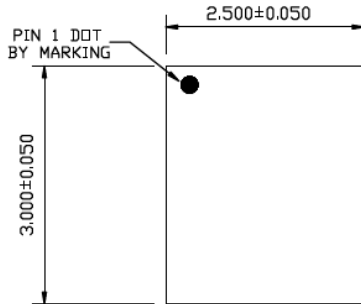

TOP VIEW  
NOTE : 1,2,3

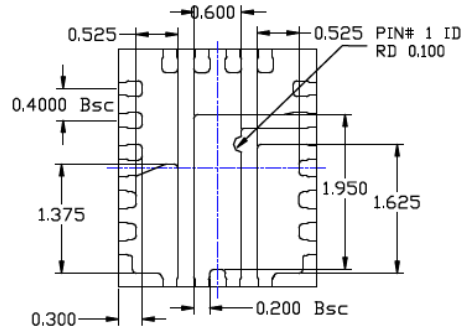

BOTTOM VIEW  
NOTE : 1,2,3

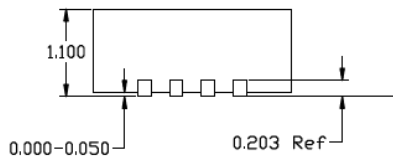

SIDE VIEW  
NOTE : 1,2,3

NOTE :

1. Max package warpage is 0.05mm.
2. Max allowable burr is 0.076mm in all directions.
3. Pin #1 will be laser marked.
4. Red circle in land pattern indicate thermal via. Size should be 0.20mm in diameter, 0.400mm pitch and should be connected to GND for max thermal performance.
5. Green rectangles (shaded area) in GND black colored pad represent stencil opening on exposed area. Size is 0.200x1.475mm.
6. Hidden lines (Optional) for improved thermal performance.
7. Blue & Magenta colored pads represent different potentials, do not connect to GND.

Note: For the most current package drawings, please see the Microchip Packaging Specification located at <http://www.microchip.com/packaging>.

**Package Outlines and Dimensions**

POD-Land Pattern drawing #GJQFN2530-20LD-PL-1

RECOMMENDED LAND PATTERN

NOTE : 4,5,6,7

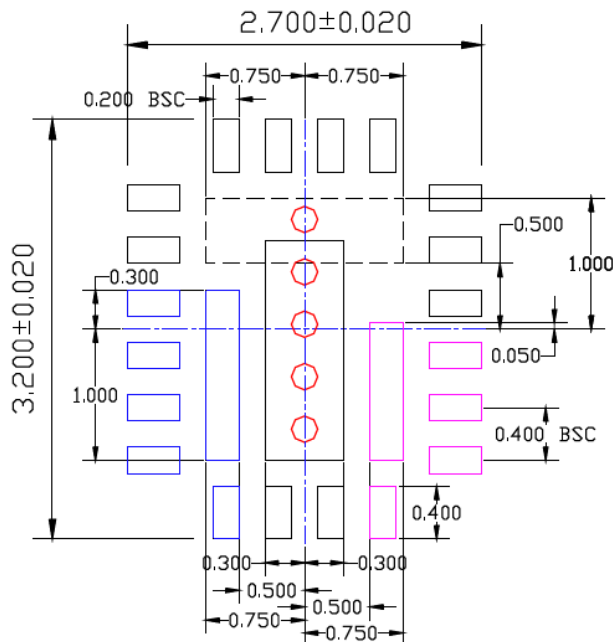
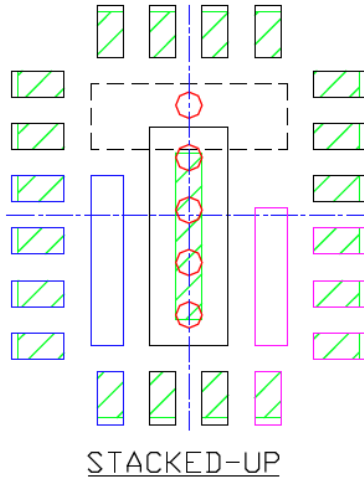

EXPOSED METAL TRACE

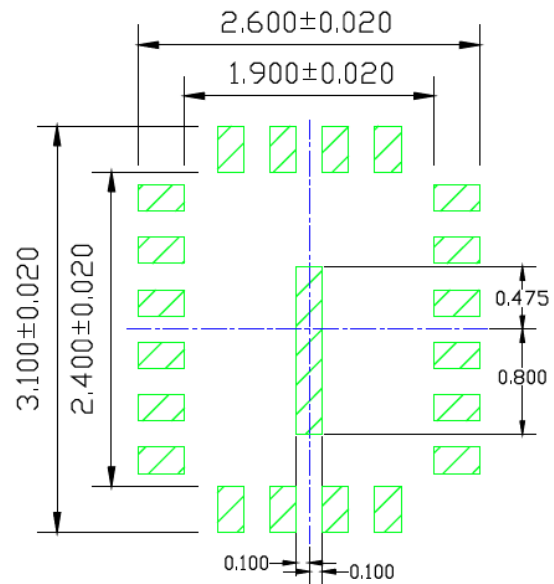

SOLDER STENCIL OPENING

Note: For the most current package drawings, please see the Microchip Packaging Specification located at <http://www.microchip.com/packaging>.



**MICROCHIP**

---

---

**Package Outlines and Dimensions**

---

---

NOTES:

---

---

**Package Outlines and Dimensions**

---

---

**GKQFN**

Micrel Legacy

## Package Outlines and Dimensions

### TITLE

20 LEAD GKQFN 2.5x3mm PKG (Flip Chip & Hybrid) OUTLINE & RECOMMENDED LAND PATTERN

<b>DRAWING #</b>	GKQFN2530-20LD-PL-1	<b>UNIT</b>	MM
<b>Lead Frame</b>	Copper	<b>Lead Finish</b>	Matte Tin

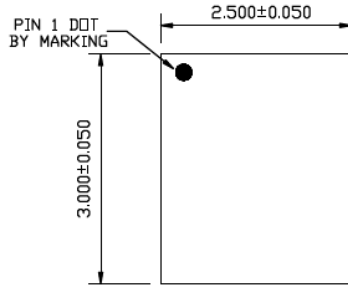

TOP VIEW

NOTE : 1,2,3

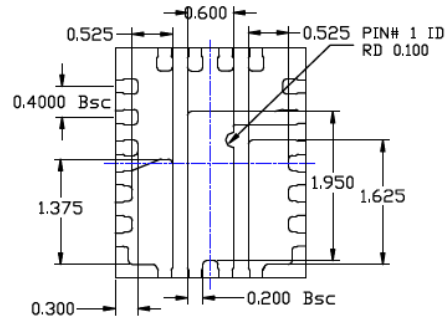

BOTTOM VIEW

NOTE : 1,2,3

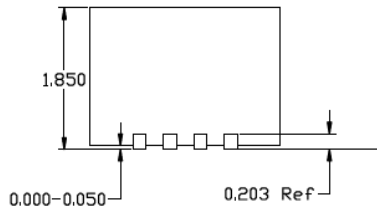

SIDE VIEW

NOTE : 1,2,3

### NOTE :

1. Max package warpage is 0.05mm.
2. Max allowable burr is 0.076mm in all directions.
3. Pin #1 will be laser marked.
4. Red circle in land pattern indicate thermal via. Size should be 0.20mm in diameter, 0.400mm pitch and should be connected to GND for max thermal performance.
5. Green rectangles (shaded area) in GND black colored pad represent stencil opening on exposed area. Size is 0.200x1.475mm.
6. Hidden lines (Optional) for improved thermal performance.
7. Blue & Magenta colored pads represent different potentials, do not connect to GND.

Note: For the most current package drawings, please see the Microchip Packaging Specification located at <http://www.microchip.com/packaging>.



**Package Outlines and Dimensions**

POD-Land Pattern drawing #GKQFN2530-20LD-PL-1

RECOMMENDED LAND PATTERN

NOTE : 4,5,6,7

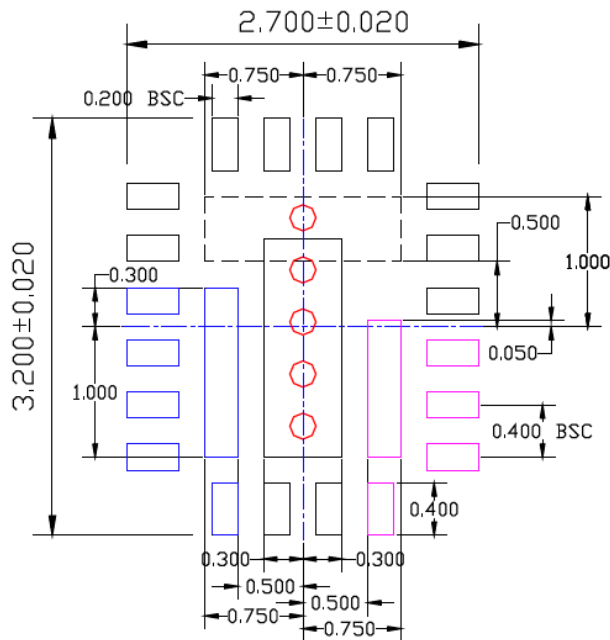
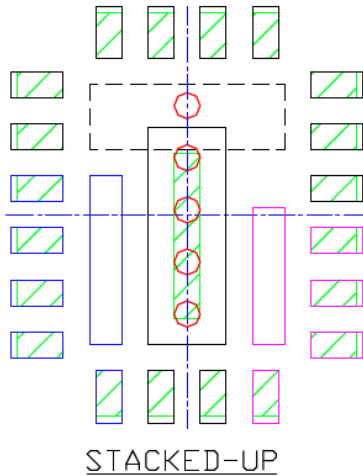

EXPOSED METAL TRACE

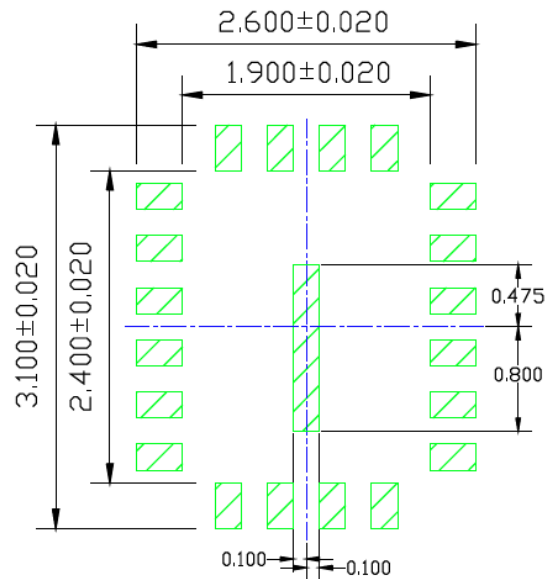

SOLDER STENCIL OPENING

Note: For the most current package drawings, please see the Microchip Packaging Specification located at <http://www.microchip.com/packaging>.



**MICROCHIP**

---

---

**Package Outlines and Dimensions**

---

---

**NOTES:**

---

---

**Package Outlines and Dimensions**

---

---

**H3QFN**

Micrel Legacy

## Package Outlines and Dimensions

**TITLE**

52 LEAD H3QFN 8x8mm PACKAGE (Module) OUTLINE & RECOMMENDED LAND PATTERN

<b>DRAWING #</b>	H3QFN88-52LD-PL-1	<b>UNIT</b>	MM
<b>Lead Frame</b>	Copper	<b>Lead Finish</b>	Matte Tin

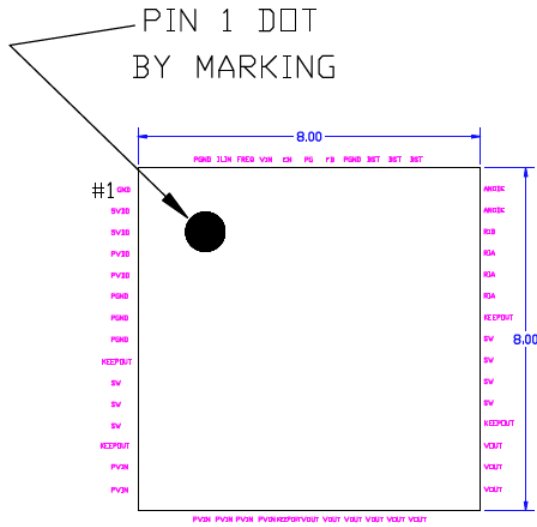

Top View

NOTE: 1, 2, 3

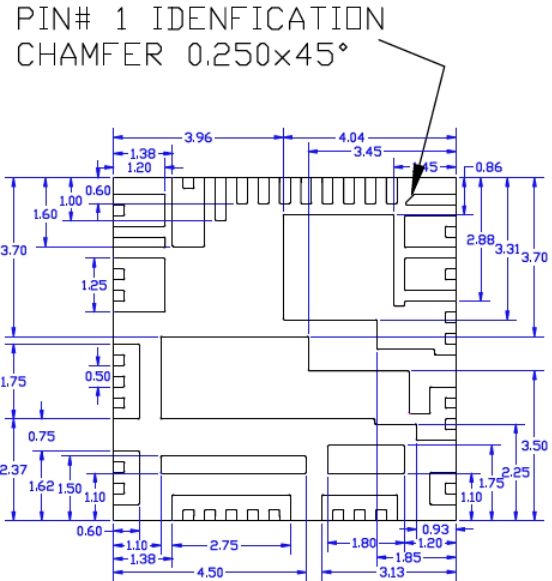

Bottom View

NOTE: 1, 2, 3

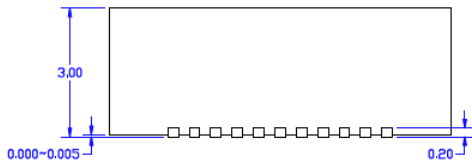

Side View

NOTE: 1, 2, 3

Note: For the most current package drawings, please see the Microchip Packaging Specification located at <http://www.microchip.com/packaging>.

**Package Outlines and Dimensions**

# Recommended Land Pattern

NOTE: 4, 5, 6

## Simplified LP

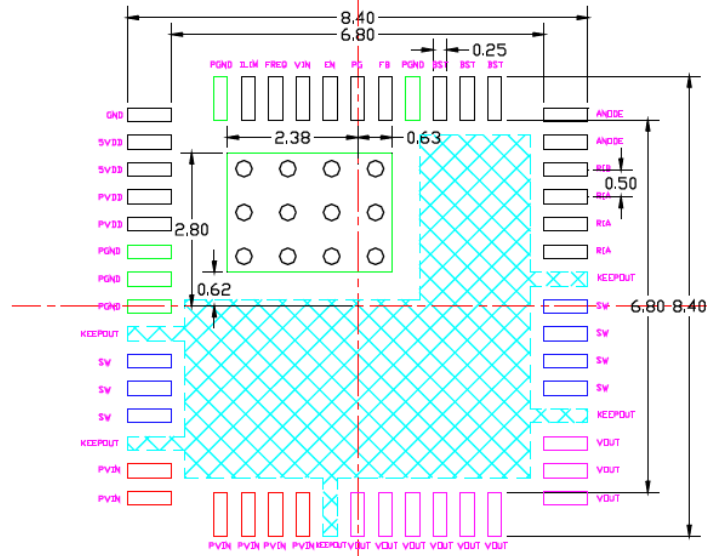

### EXPOSED METAL TRACE

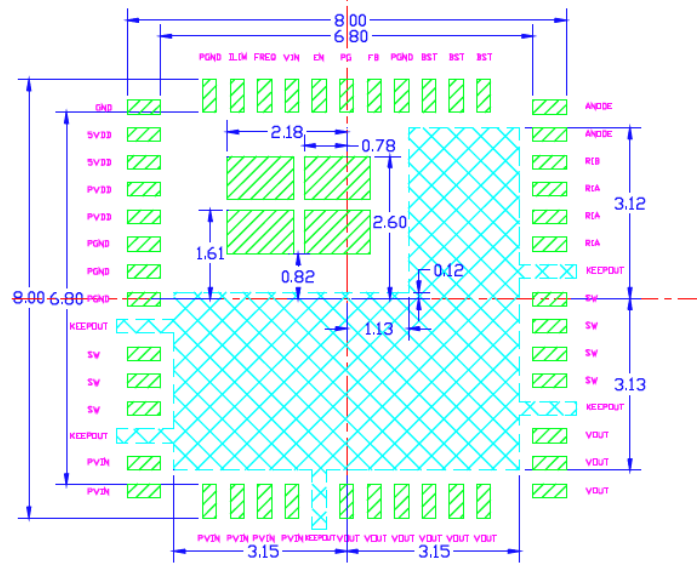

### SOLDER STENCIL OPENING

Note: For the most current package drawings, please see the Microchip Packaging Specification located at <http://www.microchip.com/packaging>.





# Recommended Land Pattern

NOTE: 4, 5, 6

## Simplified LP

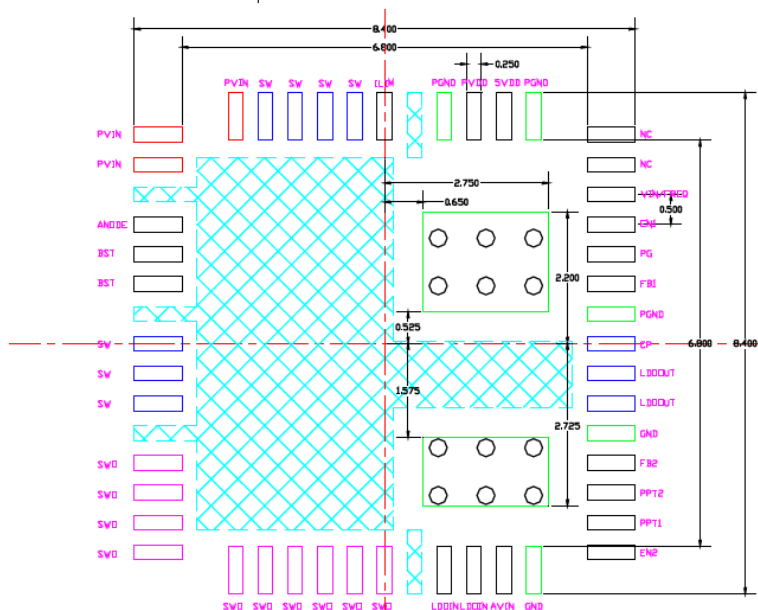

EXPOSED METAL TRACE

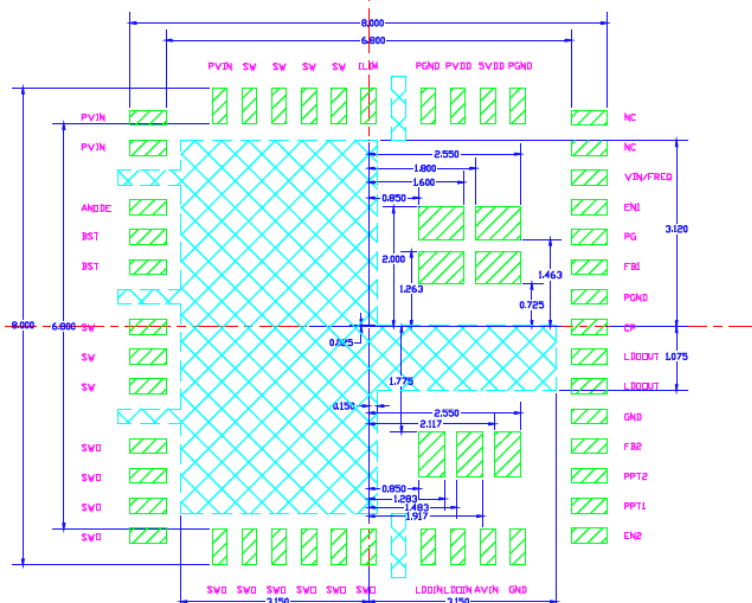

SOLDER STENCIL OPENING

Note: For the most current package drawings, please see the Microchip Packaging Specification located at <http://www.microchip.com/packaging>.



---



---

## Package Outlines and Dimensions

---



---

# Recommended Land Pattern

NOTE: 4, 5, 6

## Simplified LP

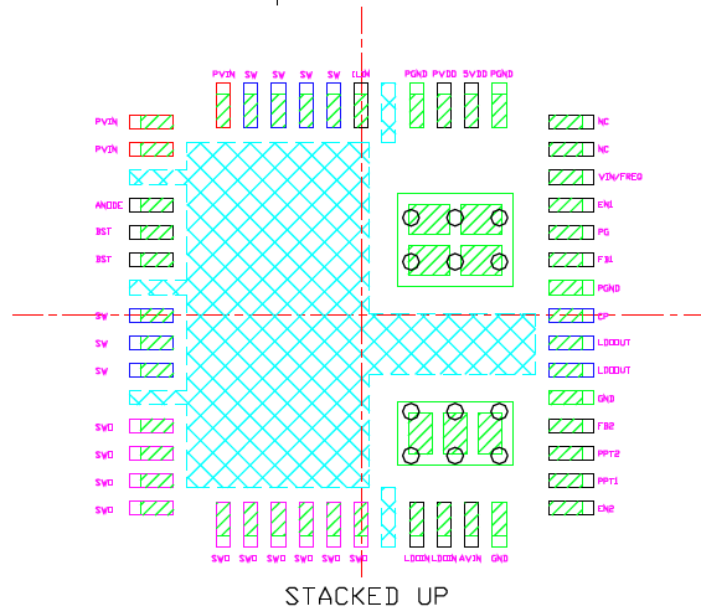

**NOTE:**

1. MAX PACKAGE WARPAGE IS 0.05 MM
2. MAX ALLOWABLE BURR IS 0.076MM IN ALL DIRECTIONS
3. PIN #1 IS ON TOP WILL BE LASER MARKED
4. BLACK CIRCLES IN LAND PATTERN REPRESENT THERMAL VIA, RECOMMENDED SIZE IS 0.30-0.35mm, AT 0.80mm PITCH & SHOULD BE CONNECTED TO GND FOR MAXIMUM PERFORMANCE.
5. GREEN RECTANGLES (SHADED AREA) REPRESENT SOLDER STENCIL OPENING ON EXPOSED PAD AREA.
6. CYAN COLORED SHADED PAD REPRESENT EXPOSED TRACE KEEP OUT AREA.

Note: For the most current package drawings, please see the Microchip Packaging Specification located at <http://www.microchip.com/packaging>.

## Package Outlines and Dimensions

**TITLE**

52 LEAD H3QFN 8x8mm PACKAGE (Module) OUTLINE & RECOMMENDED LAND PATTERN

<b>DRAWING #</b>	H3QFN88-52LD-PL-3	<b>UNIT</b>	MM
<b>Lead Frame</b>	Copper	<b>Lead Finish</b>	Matte Tin

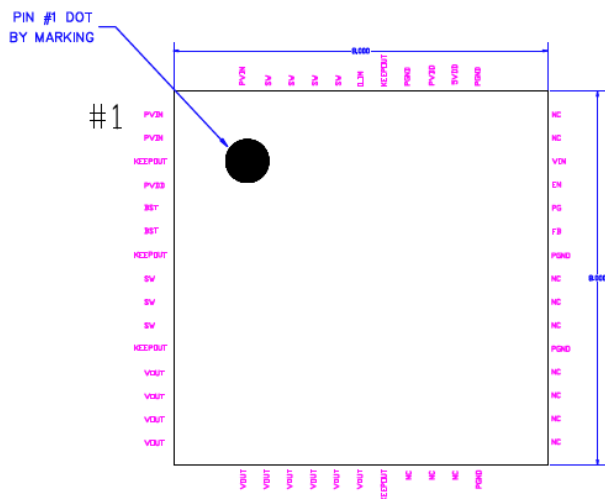

Top View

NOTE: 1, 2, 3

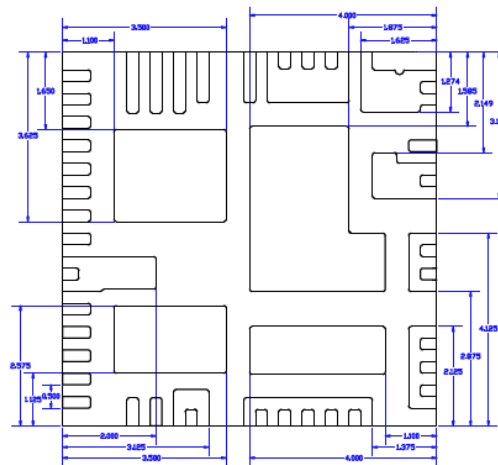

Bottom View

NOTE: 1, 2, 3

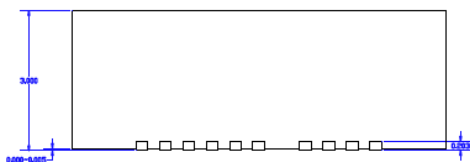

Side View

NOTE: 1, 2, 3

Note: For the most current package drawings, please see the Microchip Packaging Specification located at <http://www.microchip.com/packageing>.

**Package Outlines and Dimensions**

Recommended Land Pattern

NOTE: 4, 5, 6

Simplified LP

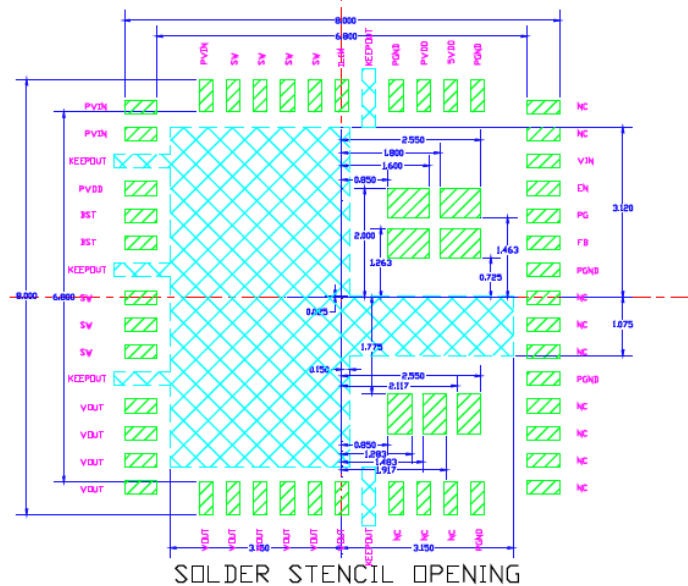
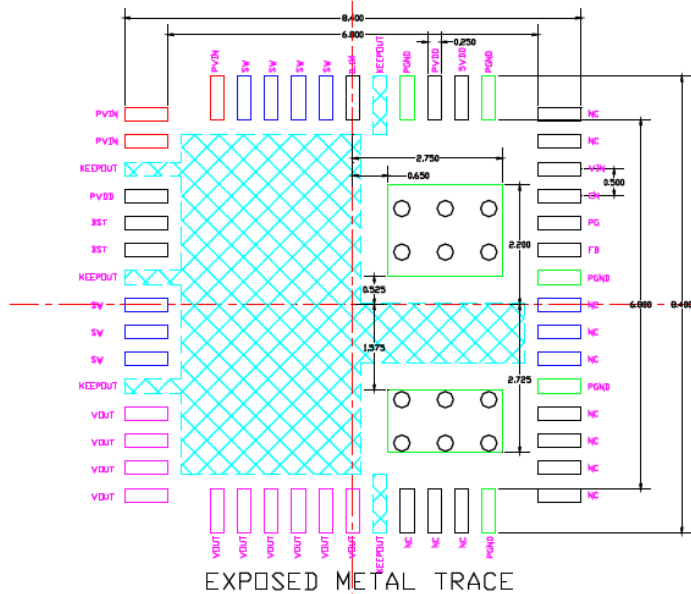

Note: For the most current package drawings, please see the Microchip Packaging Specification located at <http://www.microchip.com/packaging>.

# Recommended Land Pattern

NOTE: 4, 5, 6

## Simplified LP

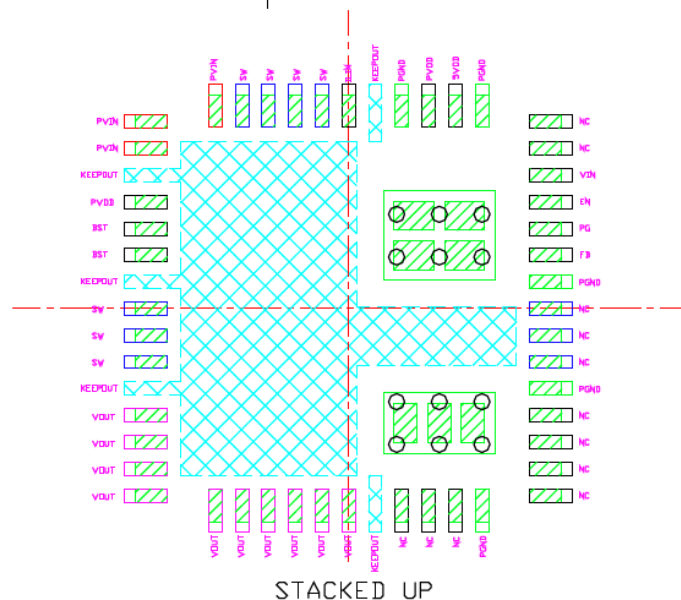

**NOTE:**

1. MAX PACKAGE WARPAGE IS 0.05 MM
2. MAX ALLOWABLE BURR IS 0.076MM IN ALL DIRECTIONS
3. PIN #1 IS ON TOP WILL BE LASER MARKED
4. BLACK CIRCLES IN LAND PATTERN REPRESENT THERMAL VIA, RECOMMENDED SIZE IS 0.30-0.35mm, AT 0.80mm PITCH & SHOULD BE CONNECTED TO GND FOR MAXIMUM PERFORMANCE.
5. GREEN RECTANGLES (SHADED AREA) REPRESENT SOLDER STENCIL OPENING ON EXPOSED PAD AREA.
6. CYAN COLORED SHADED PAD REPRESENT EXPOSED TRACE KEEP OUT AREA.

Note: For the most current package drawings, please see the Microchip Packaging Specification located at <http://www.microchip.com/packaging>.

## Package Outlines and Dimensions

**TITLE**

64 LEAD H3QFN 12x12mm PACKAGE (Module) OUTLINE & RECOMMENDED LAND PATTERN

<b>DRAWING #</b>	H3QFN1212-64LD-PL-1	<b>UNIT</b>	MM
<b>Lead Frame</b>	Copper	<b>Lead Finish</b>	Matte Tin

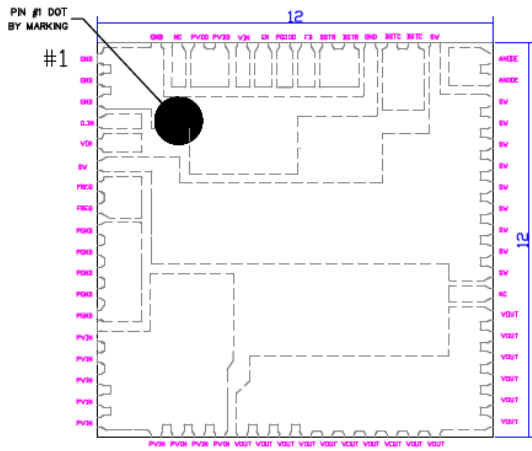

Top View  
NOTE: 1, 2, 3

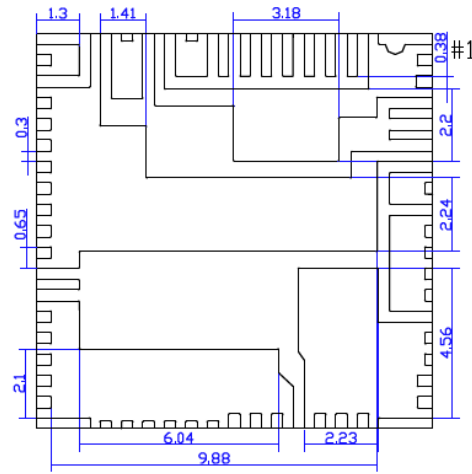

Bottom View  
NOTE: 1, 2, 3

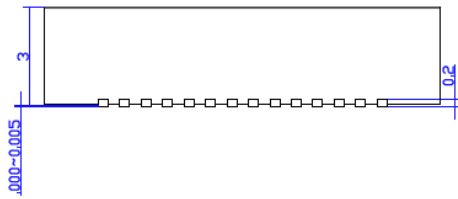

Top View  
NOTE: 1, 2, 3

Note: For the most current package drawings, please see the Microchip Packaging Specification located at <http://www.microchip.com/packaging>.

**Package Outlines and Dimensions**

Recommended Land Pattern

NOTE: 4, 5, 6

Simplified LP

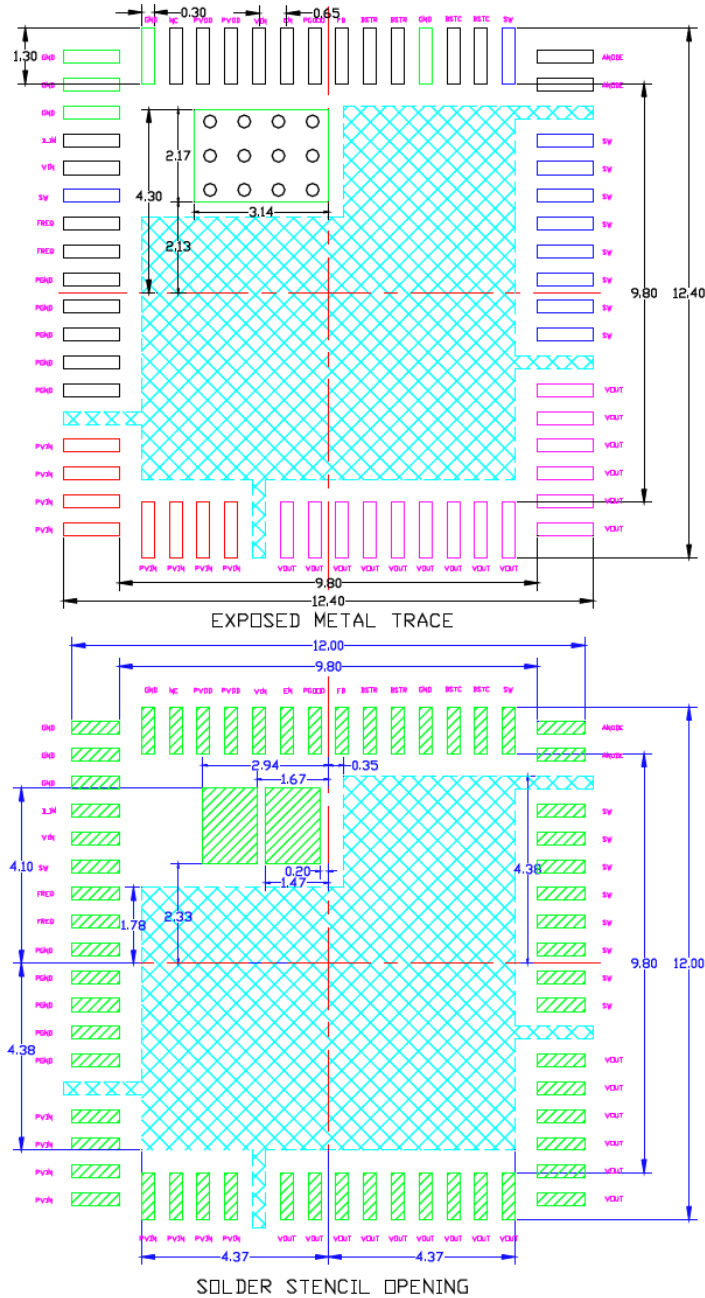

Note: For the most current package drawings, please see the Microchip Packaging Specification located at <http://www.microchip.com/packaging>.

---



---

**Package Outlines and Dimensions**

---



---

# Recommended Land Pattern

NOTE: 4, 5, 6

## Simplified LP

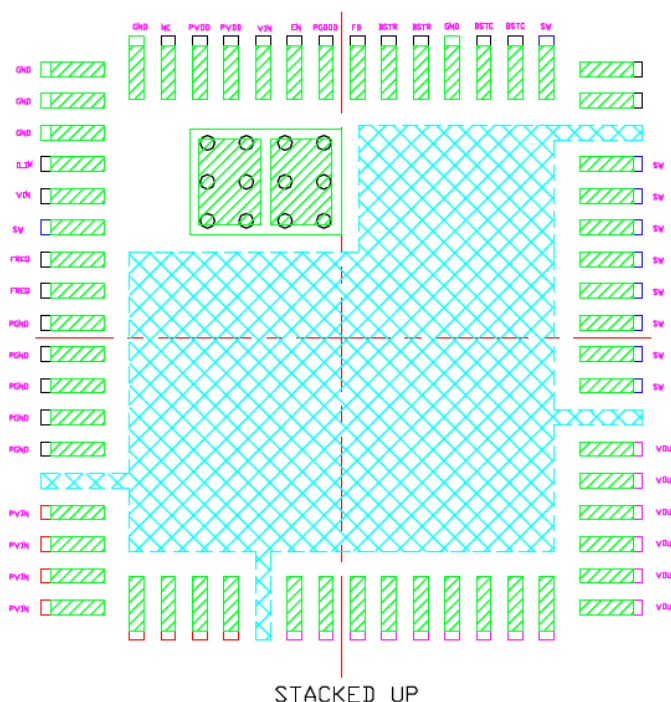

**NOTE:**

1. MAX PACKAGE WARPAGE IS 0.05 MM
2. MAX ALLOWABLE BURR IS 0.076MM IN ALL DIRECTIONS
3. PIN #1 IS ON TOP WILL BE LASER MARKED
4. BLACK CIRCLES IN LAND PATTERN REPRESENT THERMAL VIA, RECOMMENDED SIZE IS 0.30-0.35mm, AT 0.80mm PITCH & SHOULD BE CONNECTED TO GND FOR MAXIMUM PERFORMANCE.
5. GREEN RECTANGLES (SHADED AREA) REPRESENT SOLDER STENCIL OPENING ON EXPOSED PAD AREA.
6. CYAN COLORED SHADED PAD REPRESENT EXPOSED TRACE KEEP OUT AREA.

Note: For the most current package drawings, please see the Microchip Packaging Specification located at <http://www.microchip.com/packaging>.



**MICROCHIP**

---

---

**Package Outlines and Dimensions**

---

---

NOTES:



---

---

**Package Outlines and Dimensions**

---

---

**H4QFN**

Micrel Legacy

## Package Outlines and Dimensions

### TITLE

52 LEAD H4QFN 10x10mm PACKAGE (Module) OUTLINE & RECOMMENDED LAND PATTERN

<b>DRAWING #</b>	H4QFN1010-52LD-PL-1	<b>UNIT</b>	MM
<b>Lead Frame</b>	Copper	<b>Lead Finish</b>	Matte Tin

PIN 1 DOT  
BY MARKING

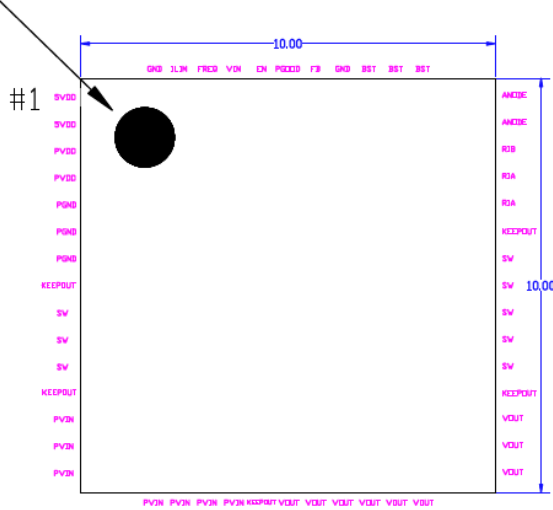

Top View

NOTE: 1, 2, 3

PIN# 1 IDENTIFICATION  
CHAMFER 0.250x45°

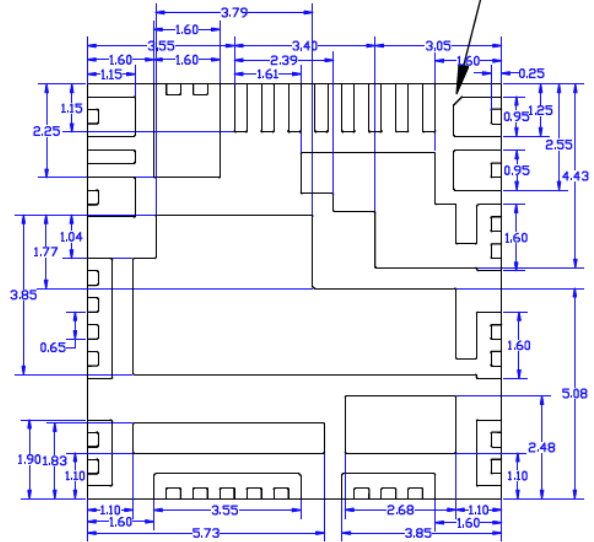

Bottom View

NOTE: 1, 2, 3

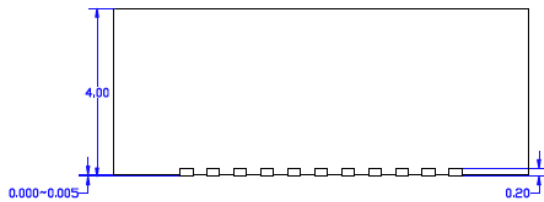

Side View

NOTE: 1, 2, 3

Note: For the most current package drawings, please see the Microchip Packaging Specification located at <http://www.microchip.com/packageing>.

Package Outlines and Dimensions

Recommended Land Pattern

NOTE: 4, 5, 6

Simplified LP

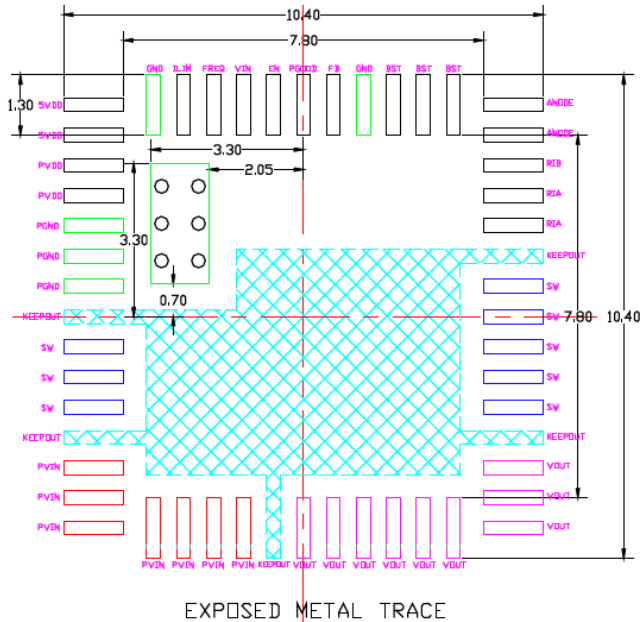

EXPOSED METAL TRACE

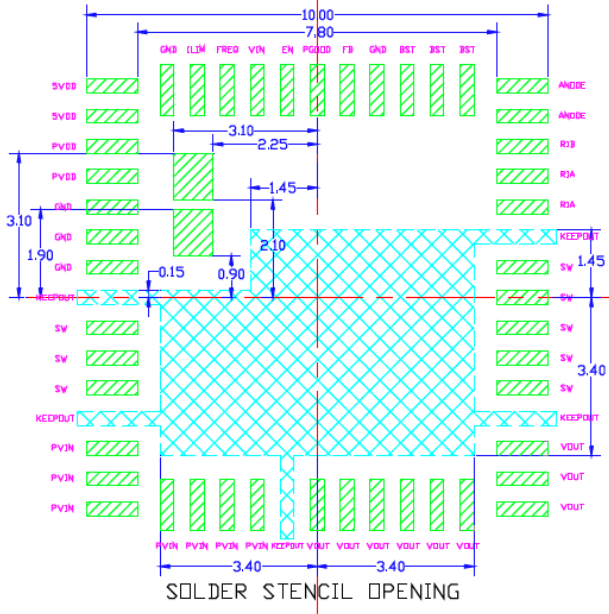

SOLDER STENCIL OPENING

Note: For the most current package drawings, please see the Microchip Packaging Specification located at <http://www.microchip.com/packageing>.

**Package Outlines and Dimensions**

Recommended Land Pattern

NOTE: 4, 5, 6

Simplified LP

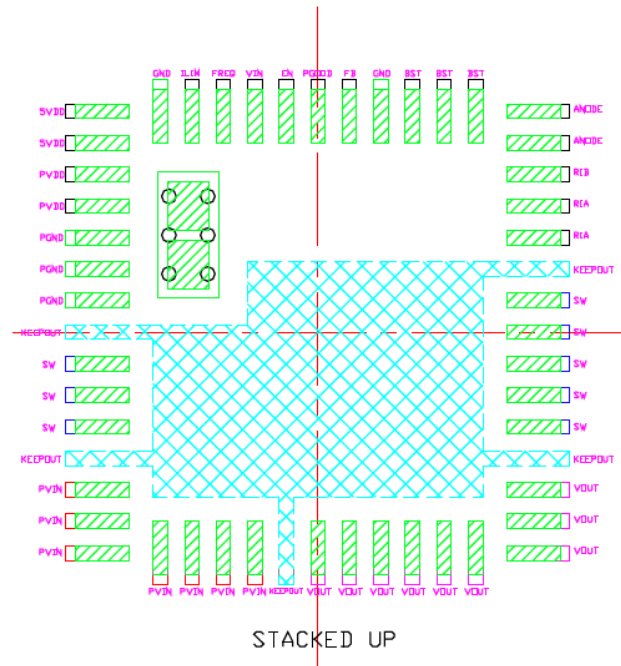

NOTE:

1. MAX PACKAGE WARPAGE IS 0.05 MM
2. MAX ALLOWABLE BURR IS 0.076MM IN ALL DIRECTIONS
3. PIN #1 IS ON TOP WILL BE LASER MARKED
4. BLACK CIRCLES IN LAND PATTERN REPRESENT THERMAL VIA, RECOMMENDED SIZE IS 0.30-0.35mm, AT 0.80mm PITCH & SHOULD BE CONNECTED TO GND FOR MAXIMUM PERFORMANCE.
5. GREEN RECTANGLES (SHADED AREA) REPRESENT SOLDER STENCIL OPENING ON EXPOSED PAD AREA.
6. CYAN COLORED SHADED PAD REPRESENT EXPOSED TRACE KEEP OUT AREA.

Note: For the most current package drawings, please see the Microchip Packaging Specification located at <http://www.microchip.com/packaging>.

## Package Outlines and Dimensions

**TITLE**

64 LEAD H4QFN 12x12mm PACKAGE (Module) OUTLINE & RECOMMENDED LAND PATTERN

<b>DRAWING #</b>	H4QFN1212-64LD-PL-1	<b>UNIT</b>	MM
<b>Lead Frame</b>	Copper	<b>Lead Finish</b>	Matte Tin

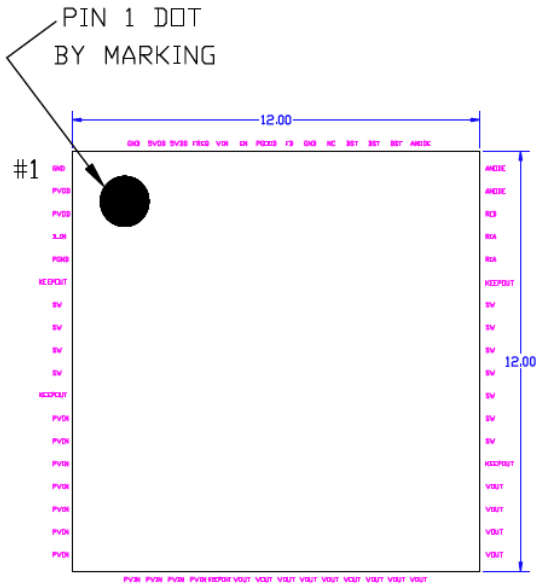

Top View

NOTE: 1, 2, 3

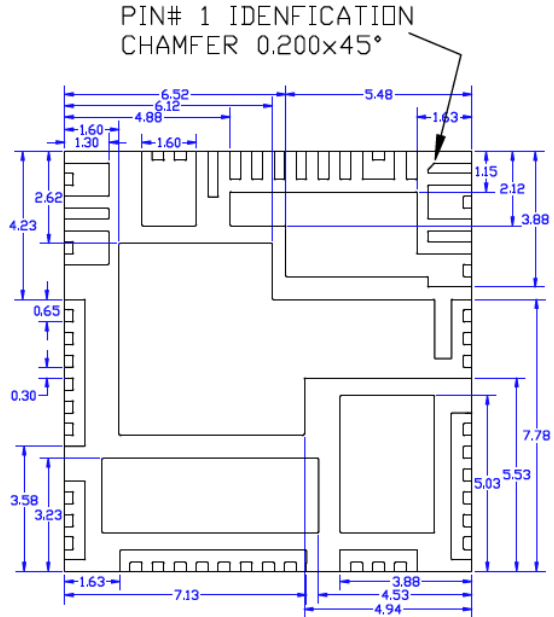

Bottom View

NOTE: 1, 2, 3

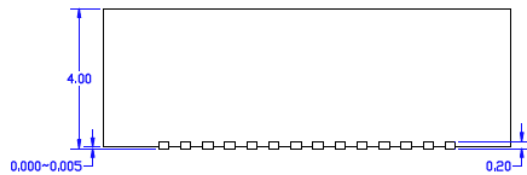

Side View

NOTE: 1, 2, 3

Note: For the most current package drawings, please see the Microchip Packaging Specification located at <http://www.microchip.com/packaging>.

**Package Outlines and Dimensions**

Recommended Land Pattern

NOTE: 4, 5, 6

Simplified LP

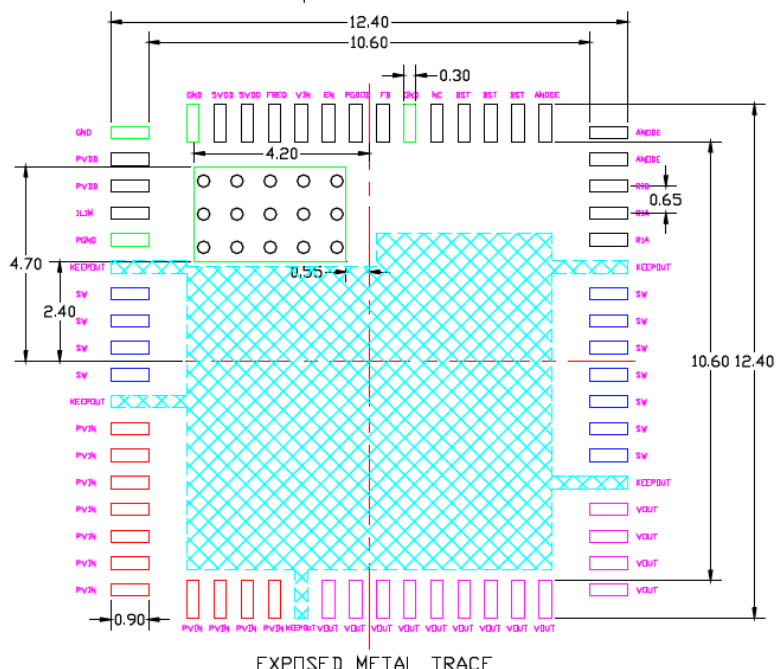

EXPOSED METAL TRACE

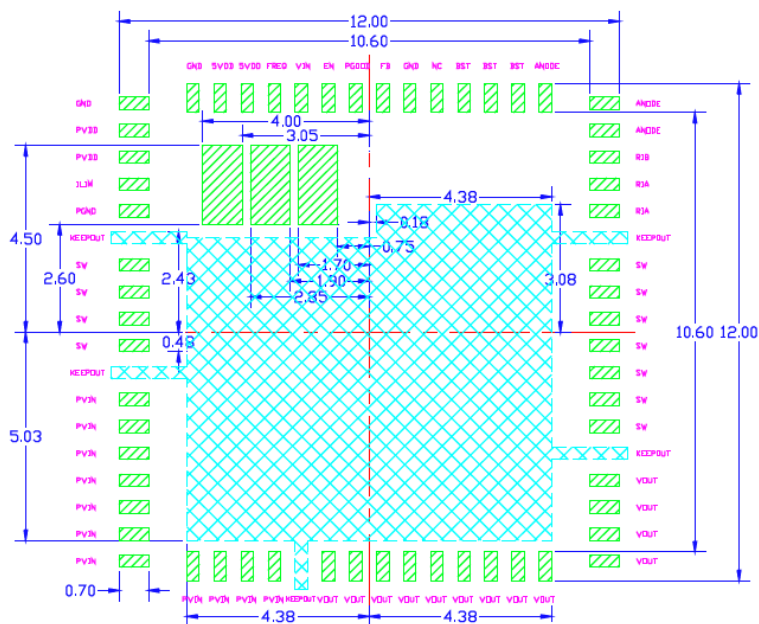

SOLDER STENCIL OPENING

Note: For the most current package drawings, please see the Microchip Packaging Specification located at <http://www.microchip.com/packaging>.

**Package Outlines and Dimensions**

Recommended Land Pattern

NOTE: 4, 5, 6

Simplified LP

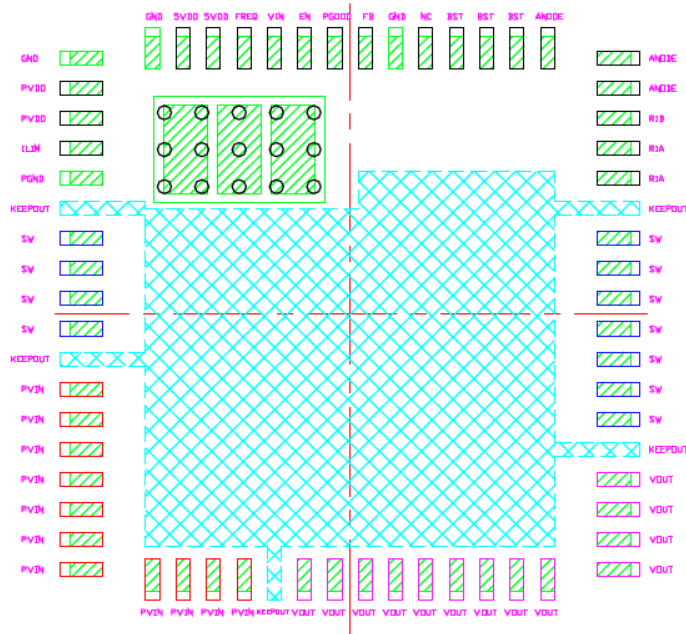

STACKED UP

NOTE:

1. MAX PACKAGE WARPAGE IS 0.05 MM
2. MAX ALLOWABLE BURR IS 0.076MM IN ALL DIRECTIONS
3. PIN #1 IS ON TOP WILL BE LASER MARKED
4. BLACK CIRCLES IN LAND PATTERN REPRESENT THERMAL VIA, RECOMMENDED SIZE IS 0.30-0.35mm, AT 0.80mm PITCH & SHOULD BE CONNECTED TO GND FOR MAXIMUM PERFORMANCE.
5. GREEN RECTANGLES (SHADED AREA) REPRESENT SOLDER STENCIL OPENING ON EXPOSED PAD AREA.
6. CYAN COLORED SHADED PAD REPRESENT EXPOSED TRACE KEEP OUT AREA.

Note: For the most current package drawings, please see the Microchip Packaging Specification located at <http://www.microchip.com/packaging>.



**MICROCHIP**

---

---

**Package Outlines and Dimensions**

---

---

**NOTES:**



---

---

**Package Outlines and Dimensions**

---

---

**HDFN**

Micrel Legacy

## Package Outlines and Dimensions

### TITLE

12 LEAD HDFN 3x3 mm PACKAGE OUTLINE & RECOMMENDED LAND PATTERN

DRAWING #	HDFN33-12LD-PL-1	UNIT	MM
-----------	------------------	------	----

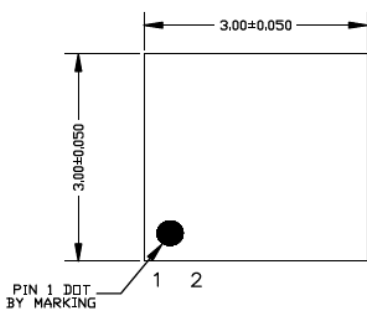

TOP VIEW  
NOTE: 1, 2, 3

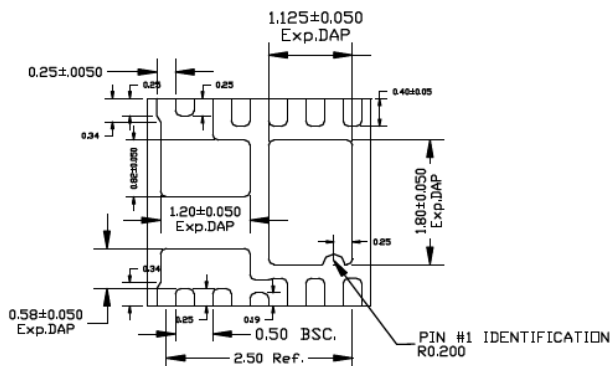

BOTTOM VIEW  
NOTE: 1, 2, 3

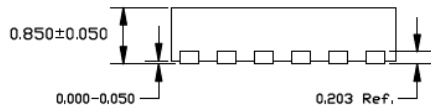

SIDE VIEW  
NOTE: 1, 2, 3

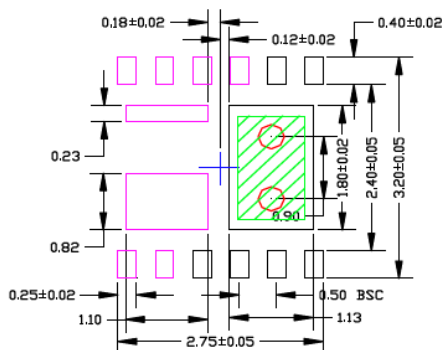

RECOMMENDED LAND PATTERN  
NOTE: 4, 5, 6

### NOTE:

1. MAX PACKAGE WARPAGE IS 0.05 MM
2. MAX ALLOWABLE BURR IS 0.076MM IN ALL DIRECTIONS
3. PIN #1 IS ON TOP WILL BE LASER MARKED
4. RED CIRCLES IN LAND PATTERN REPRESENT THERMAL VIAS. RECOMMENDED SIZE IS 0.30-0.35MM AND SHOULD BE CONNECTED TO GND FOR MAXIMUM PERFORMANCE
5. GREEN RECTANGLE REPRESENTS (OPTIONAL) SOLDER STENCIL OPENING. RECOMMENDED SIZE IS 0.90X1.50 MM.
6. PURPLE PADS REPRESENT DIFFERENT POTENTIAL. DO NOT CONNECT TO GND.

Note: For the most current package drawings, please see the Microchip Packaging Specification located at <http://www.microchip.com/packaging>.

---



---

## Package Outlines and Dimensions

---



---

**TITLE**

14 LEAD HDFN 3.0 x 3.5 mm PACKAGE OUTLINE &amp; RECOMMENDED LAND PATTERN

<b>DRAWING #</b>	HDFN3035-14LD-PL-1	<b>UNIT</b>	MM
------------------	--------------------	-------------	----

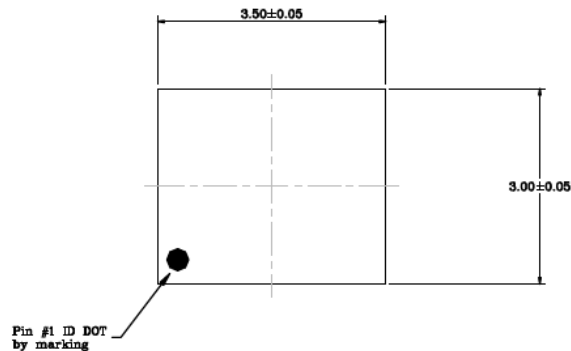
**TOP VIEW**

NOTE: 1,2,3

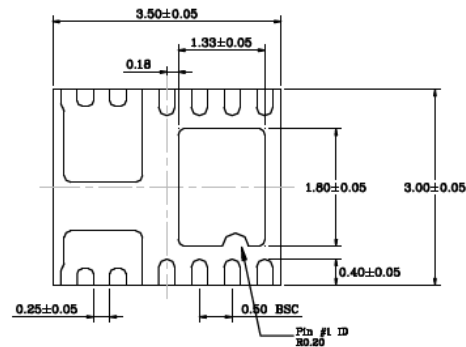
**BOTTOM VIEW**

NOTE: 1,2,3

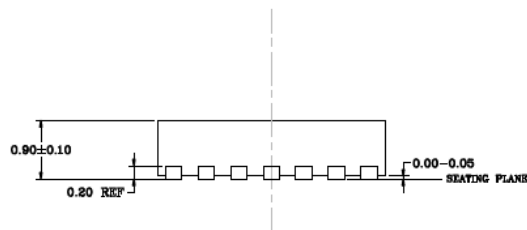
**SIDE VIEW**

NOTE: 1,2

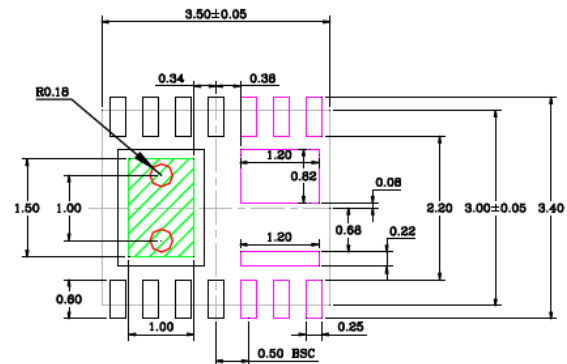
**RECOMMENDED LAND PATTERN**

NOTE: 4,5,6,7

**NOTE:**

1. MAX PACKAGE WARPAGE IS 0.05mm.
2. MAX ALLOWABLE BURR IS 0.076mm IN ALL DIRECTIONS.
3. PIN #1 IS ON TOP WILL BE LASER MARKED.
4. RED CIRCLES IN RECOMMENDED LAND PATTERN ARE THERMAL VIAS. SIZE IS 0.30-0.35mm AND SHOULD BE CONNECTED TO GND FOR MAXIMUM PERFORMANCE
5. GREEN RECTANGLE REPRESENTS (OPTIONAL) SOLDER STENCIL OPENING. RECOMMENDED SIZE IS 1.0X1.5MM.
6. PURPLE PADS REPRESENT DIFFERENT POTENTIAL. DO NOT CONNECT TO GND.
7. RECOMMENDED LAND PATTERN TOLERANCE IS ±0.02 UNLESS SPECIFIED.

Note: For the most current package drawings, please see the Microchip Packaging Specification located at <http://www.microchip.com/packageing>.



**MICROCHIP**

---

---

**Package Outlines and Dimensions**

---

---

**NOTES:**

---

---

**Package Outlines and Dimensions**

---

---

**HJDFN**

Micrel Legacy

**Package Outlines and Dimensions**

**TITLE**

10 LEAD HJDFN 2.5 x 2.0 mm PACKAGE OUTLINE & RECOMMENDED LAND PATTERN

DRAWING #	HJDFN2520-10LD-PL-1	UNIT	MM
-----------	---------------------	------	----

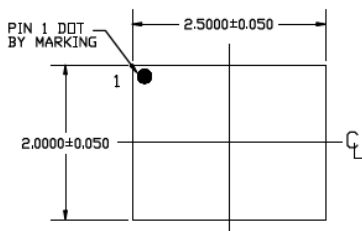

TOP VIEW

NOTE: 1, 2, 3

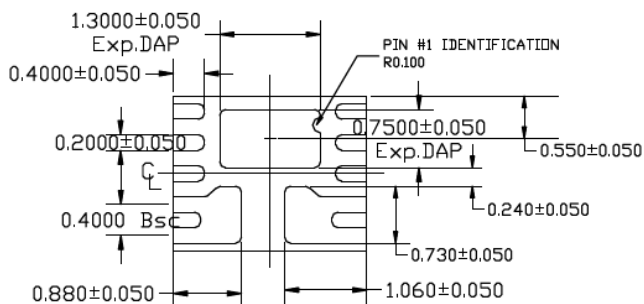

BOTTOM VIEW

NOTE: 1, 2

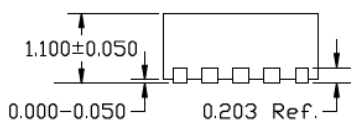

SIDE VIEW

NOTE: 1, 2

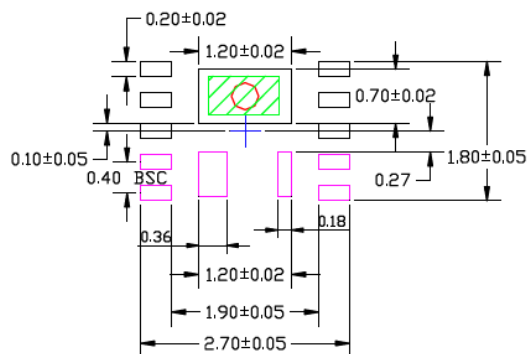

RECOMMENDED LAND PATTERN

NOTE: 4, 5, 6

**NOTE:**

1. MAX PACKAGE WARPAGE IS 0.05MM
2. MAX ALLOWABLE BURR IS 0.076MM IN ALL DIRECTIONS
3. PIN #1 IS ON TOP WILL BE LASER MARKED
4. GREEN RECTANGLE (SHADED AREA) REPRESENTS STENCIL OPENING ON EXPOSED AREA. SIZE IS 0.90X0.50 MM
5. RED CIRCLE REPRESENTS THERMAL VIAS & SHOULD BE CONNECTED TO GND FOR MAX PERFORMANCE. 0.30 - 0.35 MM RECOMMENDED DIAMETER
6. PURPLE PADS ARE OF A DIFFERENT POTENTIAL, DO NOT CONNECT TO GND

Note: For the most current package drawings, please see the Microchip Packaging Specification located at <http://www.microchip.com/packaging>.

---



---

## Package Outlines and Dimensions

---



---

**TITLE**

14 LEAD HJDFN 3.0 x 3.5 mm PACKAGE OUTLINE &amp; RECOMMENDED LAND PATTERN

DRAWING #	HJDFN3035-14LD-PL-1	UNIT	MM
-----------	---------------------	------	----

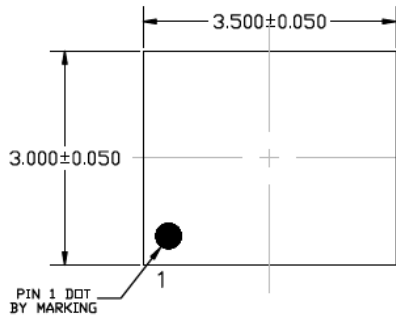

TOP VIEW  
NOTE: 1, 2, 3

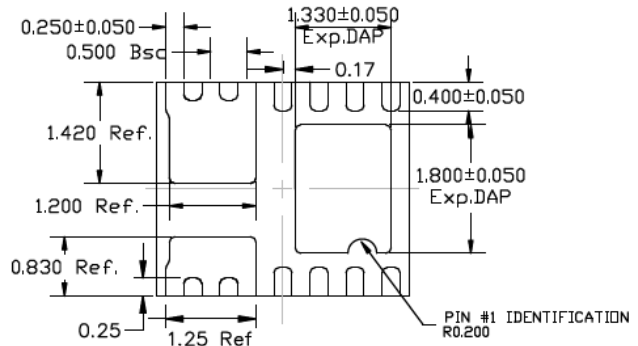

BOTTOM VIEW  
NOTE: 1, 2, 3

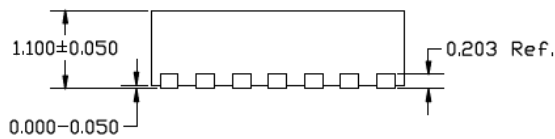

SIDE VIEW  
NOTE: 1, 2, 3

**NOTE:**

1. MAX PACKAGE WARPAGE IS 0.05mm.
2. MAX ALLOWABLE BURR IS 0.076mm IN ALL DIRECTIONS.
3. PIN #1 IS ON TOP WILL BE LASER MARKED.
4. RED CIRCLES IN RECOMMENDED LAND PATTERN ARE THERMAL VIAS. SIZE IS 0.30-0.35mm AND SHOULD BE CONNECTED TO GND FOR MAXIMUM PERFORMANCE
5. GREEN RECTANGLE REPRESENTS (OPTIONAL) SOLDER STENCIL OPENING.
6. PURPLE PADS REPRESENT DIFFERENT POTENTIAL. DO NOT CONNECT TO GND.

Note: For the most current package drawings, please see the Microchip Packaging Specification located at <http://www.microchip.com/packaging>.

**Package Outlines and Dimensions**

POD-Land Pattern drawing # HJDFN3035-14LD-PL-1

RECOMMENDED LAND PATTERN

NOTE: 4, 5, 6

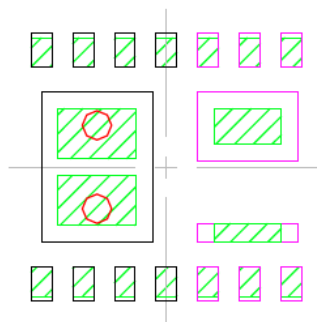

STACKED-UP

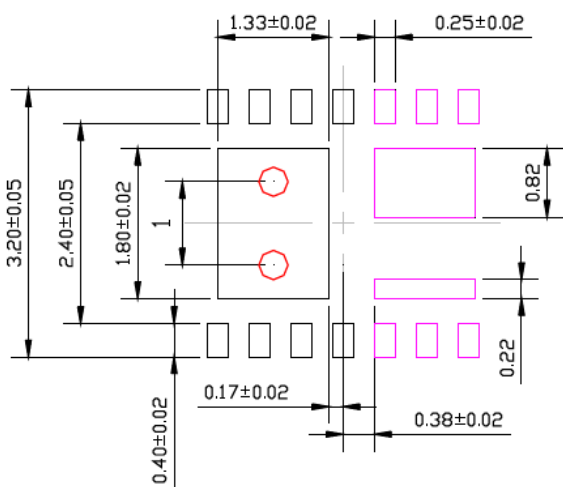

EXPOSED METAL TRACE

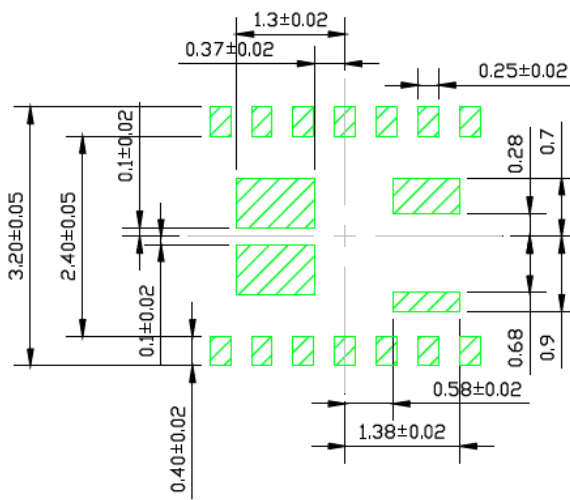

SOLDER STENCIL OPENING

Note: For the most current package drawings, please see the Microchip Packaging Specification located at <http://www.microchip.com/packaging>.



---

---

**Package Outlines and Dimensions**

---

---

**HKQFN**

Micrel Legacy

## Package Outlines and Dimensions

### TITLE

34 LEAD HQFN 4 x 6 mm PACKAGE OUTLINE & RECOMMENDED LAND PATTERN

<b>DRAWING #</b>	HKQFN46-34LD-PL-1	<b>UNIT</b>	MM
<b>Lead Frame</b>	NiPdAu	<b>Lead Finish</b>	NiPdAu

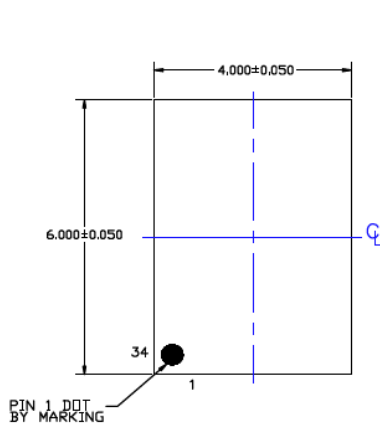

**TOP VIEW**  
NOTE: 1, 2, 3

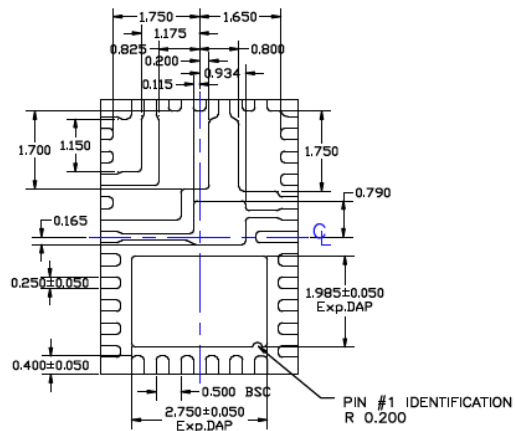

**BOTTOM VIEW**  
NOTE: 1, 2, 3

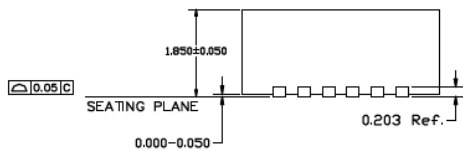

**SIDE VIEW**  
NOTE: 1, 2, 3

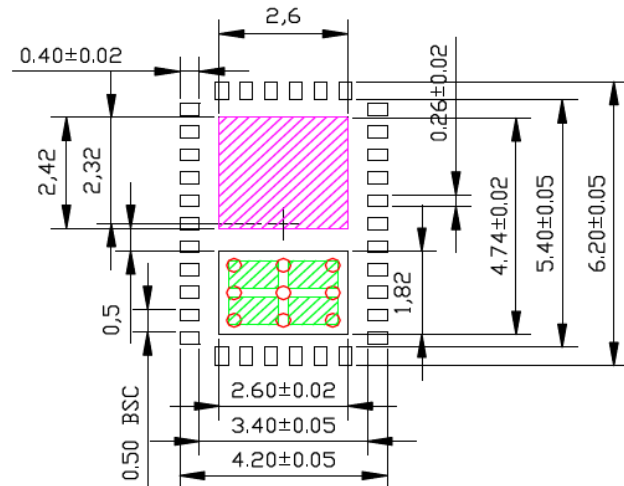

**RECOMMENDED LAND PATTERN**

NOTE: 4, 5, 6

- NOTE:
1. MAX PACKAGE WARPAGE IS 0.05 MM
  2. MAX ALLOWABLE BURR IS 0.076MM IN ALL DIRECTIONS
  3. PIN #1 IS ON TOP WILL BE LASER MARKED
  4. RED CIRCLES IN LAND PATTERN REPRESENT THERMAL VIAS. RECOMMENDED SIZE IS 0.30-0.35MM, AT 0.60-1.00MM PITCH AND SHOULD BE CONNECTED TO GND FOR MAXIMUM PERFORMANCE
  5. GREEN RECTANGLE REPRESENTS (OPTIONAL) SOLDER STENCIL OPENING. RECOMMENDED SIZE IS 1.0X0.6MM, 0.2MM SPACING
  6. PURPLE PAD REPRESENTS EXPOSED TRACE KEEP OUT AREA

Note: For the most current package drawings, please see the Microchip Packaging Specification located at <http://www.microchip.com/packaging>.

---

---

**Package Outlines and Dimensions**

---

---

**HQFN**

Micrel Legacy

## Package Outlines and Dimensions

### TITLE

28 LEAD HQFN 4 x 6 mm (TRI-SIDE) PACKAGE OUTLINE & RECOMMENDED LAND PATTERN

DRAWING #	HQFN46-28LD-PL-1	UNIT	MM
-----------	------------------	------	----

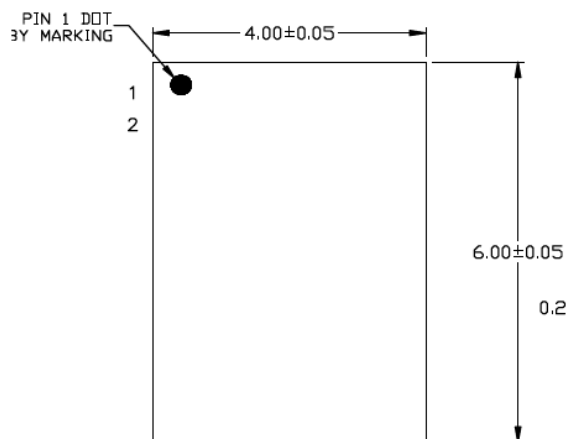

TOP VIEW

NOTE: 1, 2, 3

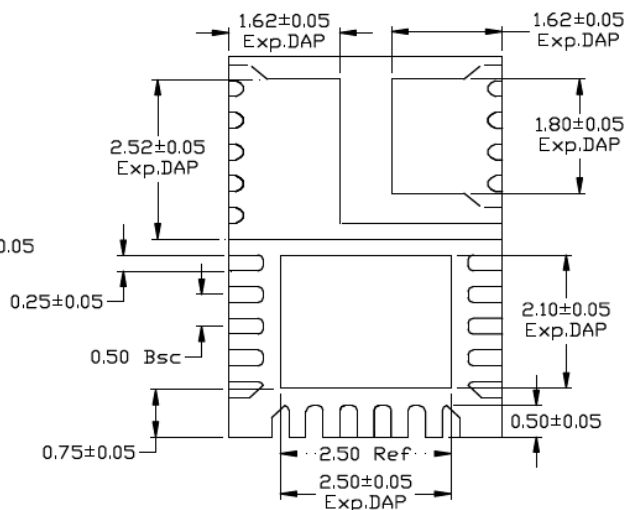

BOTTOM VIEW

NOTE: 1, 2, 3

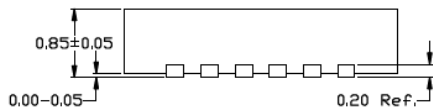

SIDE VIEW

NOTE: 1, 2, 3

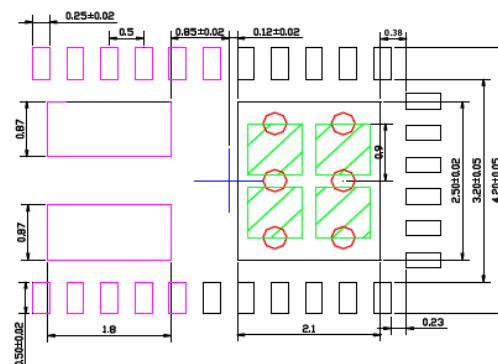

RECOMMENDED LAND PATTERN

NOTE: 4, 5, 6

#### NOTE:

1. MAX PACKAGE WARPAGE IS 0.05 MM
2. MAX ALLOWABLE BURR IS 0.076MM IN ALL DIRECTIONS
3. PIN #1 IS ON TOP WILL BE LASER MARKED
4. RED CIRCLES IN LAND PATTERN REPRESENT THERMAL VIAS. RECOMMENDED SIZE IS 0.30-0.35MM AND SHOULD BE CONNECTED TO GND FOR MAXIMUM PERFORMANCE
5. GREEN RECTANGLES REPRESENT (OPTIONAL) SOLDER STENCIL OPENING. RECOMMENDED SIZE IS 0.8×0.8MM, 0.2MM SPACING.
6. PURPLE PADS REPRESENT DIFFERENT POTENTIAL. DO NOT CONNECT TO GND.

Note: For the most current package drawings, please see the Microchip Packaging Specification located at <http://www.microchip.com/packaging>.

---

---

**Package Outlines and Dimensions**

---

---

**LDFN**

Micrel Legacy

## Package Outlines and Dimensions

### TITLE

14 LEAD LDFN 3x2mm PACKAGE OUTLINE & RECOMMENDED LAND PATTERN

DRAWING #	LDFN32-14LD-PL-1	UNIT	MM
-----------	------------------	------	----

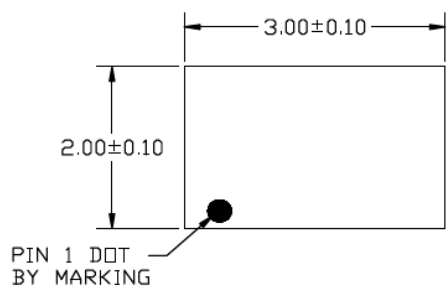

TOP VIEW

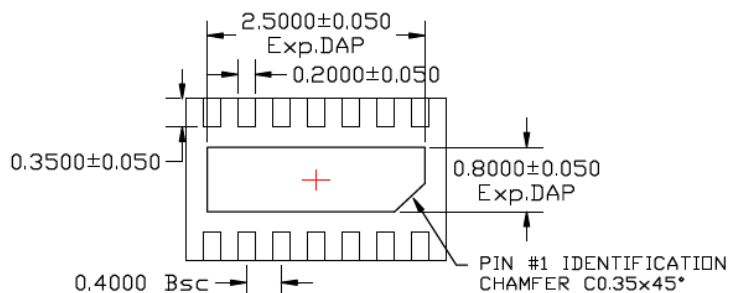

BOTTOM VIEW

NOTE: 1

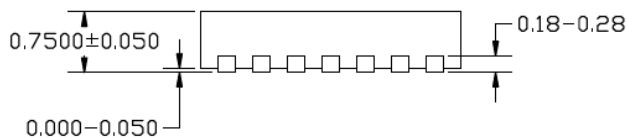

SIDE VIEW

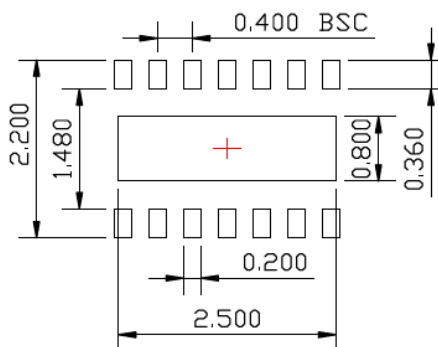

RECOMMENDED LAND PATTERN

### NOTE:

1. LEADS AND EPAD CORNER MAXIMUM RADIUS 0.075MM

Note: For the most current package drawings, please see the Microchip Packaging Specification located at <http://www.microchip.com/packaging>.

---

---

**Package Outlines and Dimensions**

---

---

**LFBGA**

Micrel Legacy

## Package Outlines and Dimensions

### TITLE

100 LEAD LFBGA 9x9mm PACKAGE OUTLINE & RECOMMENDED LAND PATTERN

<b>DRAWING #</b>	LFBGA9x9-100LD-PL-1	<b>UNIT</b>	MM
------------------	---------------------	-------------	----

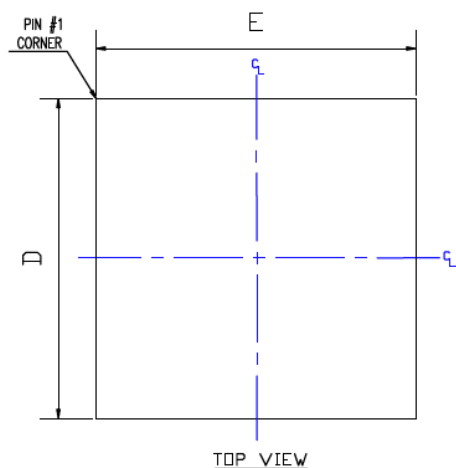

TOP VIEW

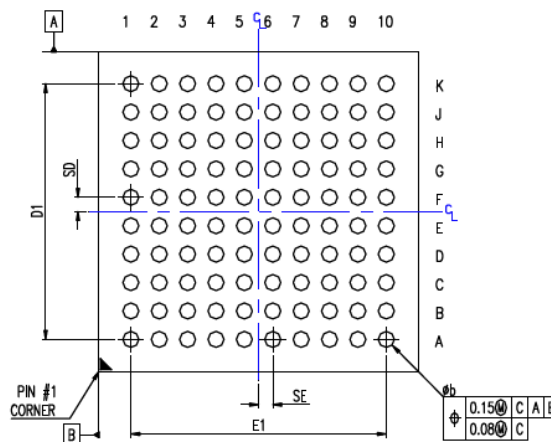

BOTTOM VIEW

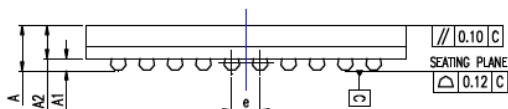

SIDE VIEW

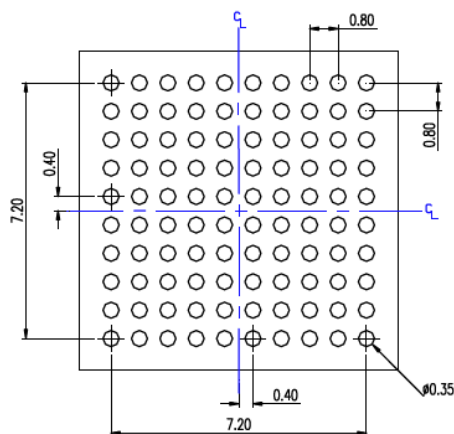

RECOMMENDED LAND PATTERN

NOTE 1

SYMBOL	DIMENSION IN MM		
	MIN.	NOM.	MAX.
A	1.16	1.27	1.38
A1	0.30	0.35	0.40
A2	0.86	0.92	0.98
b	0.40	0.45	0.50
D	8.90	9.00	9.10
D1	7.20 BSC.		
E	8.90	9.00	9.10
E1	7.20 BSC.		
SD	0.40 BSC.		
SE	0.40 BSC.		
N	100		
e	0.8 BSC.		
JEDEC	MO-219 (REF.)		

NOTE 1  
1. ALL UNITS IN mm. TOLERANCE +/- 0.05 IF NOT NOTED.

Note: For the most current package drawings, please see the Microchip Packaging Specification located at <http://www.microchip.com/packaging>.



## Package Outlines and Dimensions

**TITLE**

100 LEAD LFBGA 10x10mm PACKAGE OUTLINE &amp; RECOMMENDED LAND PATTERN

<b>DRAWING #</b>	LFBGA10x10-100LD-PL-1	<b>UNIT</b>	MM
------------------	-----------------------	-------------	----

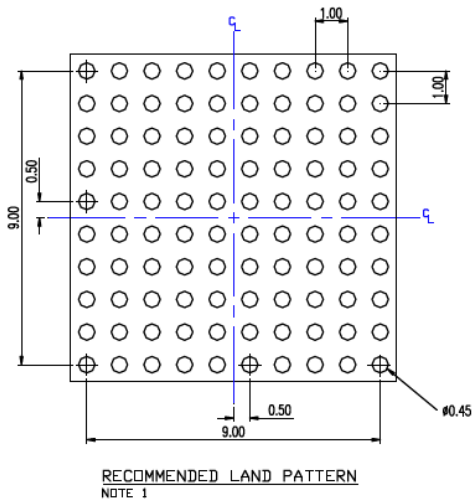
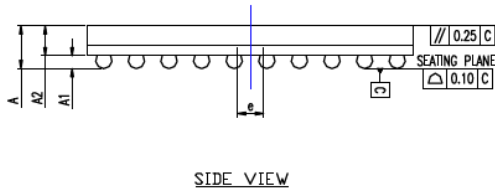
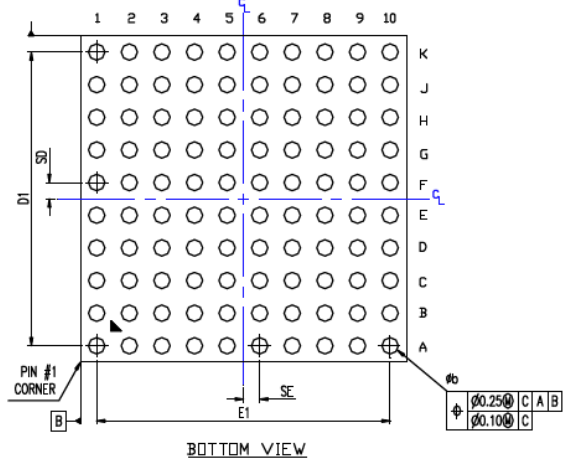
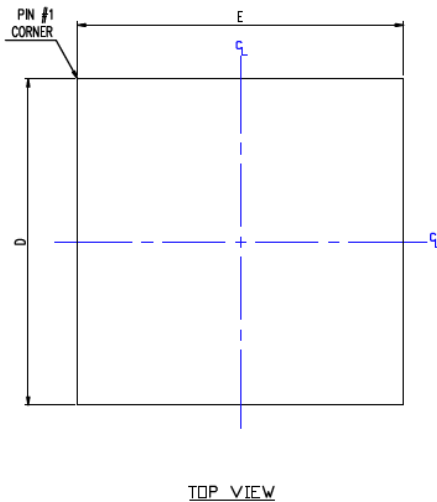

SYMBOL	DIMENSION IN MM			DIMENSION IN INCH		
	MIN.	NOM.	MAX.	MIN.	NOM.	MAX.
A	1.20	1.31	1.42	0.047	0.052	0.056
A1	0.34	0.39	0.44	0.013	0.015	0.017
A2	0.86	0.92	0.98	0.034	0.036	0.039
b	0.45	0.50	0.55	0.018	0.020	0.022
D	9.90	10.00	10.10	0.390	0.394	0.398
E	9.90	10.00	10.10	0.390	0.394	0.398
e	1.00 BSC.			0.039 BSC.		
JEDEC	MO-192(REF.)					
SE	0.50 BSC.			0.020 BSC.		
SD	0.50 BSC.			0.020 BSC.		
E1	9.00 BSC.			0.351 BSC.		
D1	9.00 BSC.			0.351 BSC.		

NOTE :  
1. TOLERANCE +/- 0.05 IF NOT NOTED

Note: For the most current package drawings, please see the Microchip Packaging Specification located at <http://www.microchip.com/packaging>.



**MICROCHIP**

---

---

**Package Outlines and Dimensions**

---

---

**NOTES:**

---

---

**Package Outlines and Dimensions**

---

---

**LGA**

Micrel Legacy

## Package Outlines and Dimensions

### TITLE

6 LEAD LGA 5.0x3.2 mm PACKAGE OUTLINE & RECOMMENDED LAND PATTERN

<b>DRAWING #</b>	LGA5032-6LD-PL-1	<b>UNIT</b>	MM
------------------	------------------	-------------	----

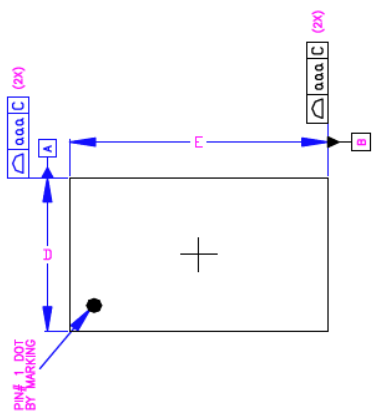

TOP VIEW

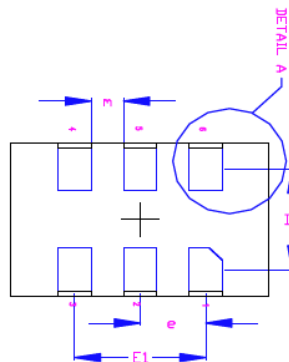

BOTTOM VIEW

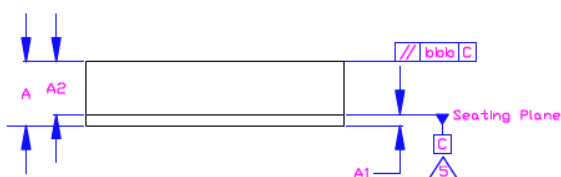

SIDE VIEW

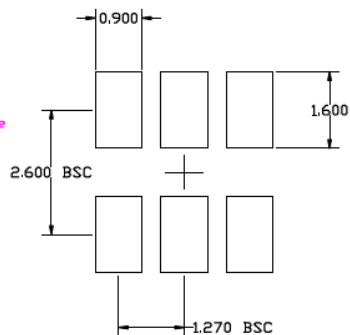

RECOMMENDED LAND PATTERN

Dimensional Tol.			
aaa	0.100		
bbb	0.070		
Dimensional Ref.			
REF.	Min.	Nom.	Max.
A	1.260	1.330	1.400
A1	0.190	0.230	0.270
A2	1.070	1.100	1.130
D	3.100	3.200	3.300
D1	2.100 BSC		
E	4.900	5.000	5.100
E1	2.540 BSC		
b	0.850	1.900	0.950
c	0.850	0.900	0.950
e	1.270 BSC		
f	0.050	0.100	0.150
k	0.860	0.910	0.960
m	0.580	0.630	0.680
n	6		

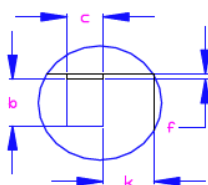

DETAIL A  
SCALE 5:1

### Notes

1. Dimensioning and Tolerancing per ASME Y14.5M-1994.
2. Dimensions are in millimeters.
3. 'e' represents the basic LGA pitch
4. 'n' is the maximum no. of Land for a specified Package.
5. Package warp shall be 0.050 max.
6. Substrate base is BT Resin
7. The Pin#1 corner must be identified on top side only.
8. Reference Jeduc Spec M0-220

Note: For the most current package drawings, please see the Microchip Packaging Specification located at <http://www.microchip.com/packaging>.

## Package Outlines and Dimensions

**TITLE**

6 LEAD LGA 7x5 mm PACKAGE OUTLINE &amp; RECOMMENDED LAND PATTERN

<b>DRAWING #</b>	LGA75-6LD-PL-1	<b>UNIT</b>	MM
------------------	----------------	-------------	----

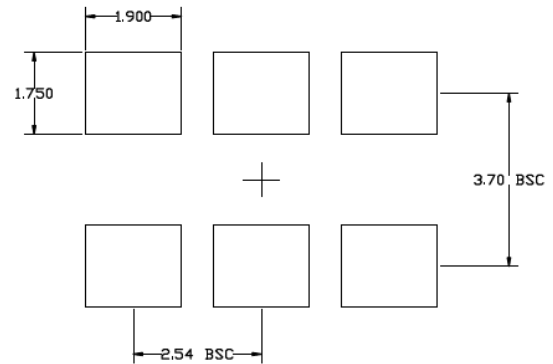
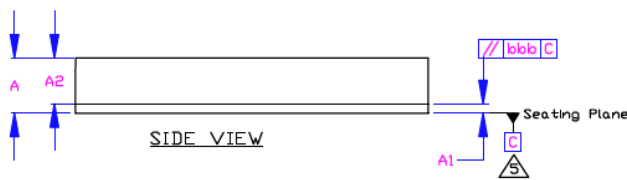
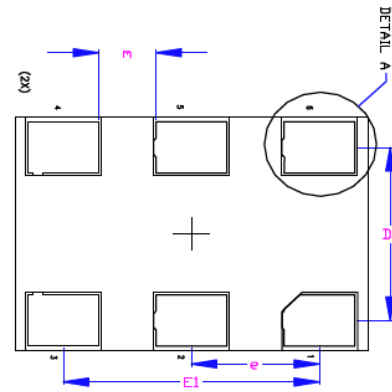
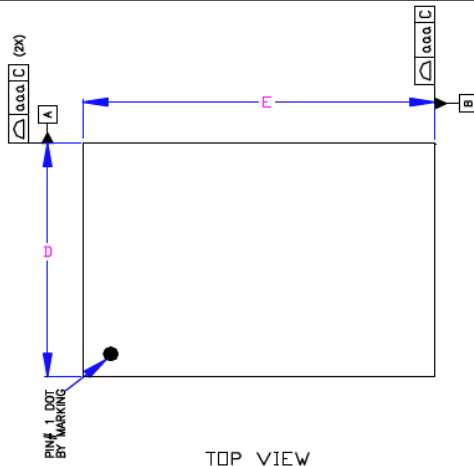

Dimensional Tol.			
aaa		0.101	
bbb		0.171	
Dimensional Ref.			
REF.	Min.	Nom.	Max.
A	1.260	1.331	1.400
A1	0.190	0.230	0.270
A2	1.070	1.100	1.130
D	4.900	5.000	5.100
D1		3.700 BSC	
E	6.900	7.000	7.100
E1		5.000 BSC	
b	1.051	1.110	1.150
c	1.351	1.400	1.450
e		2.540 BSC	
f	1.050	0.100	0.151
k	1.210	0.260	0.311
m	1.090	1.140	1.191
n		36	

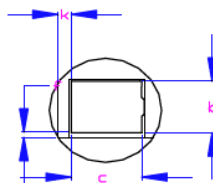

SCALE 5:1

**Notes**

1. Dimensioning and Tolerancing per ASME Y14.5M-1994.
2. Dimensions are in millimeters.
3. 'e' represents the basic LGA pitch
4. 'n' is the maximum no. of Land for a specified Package.
5. Package warp shall be 0.050 max.
6. Substrate base is BT Resin
7. The Pin#1 corner must be identified on top side only.
8. Reference Jeduc Spec MI-221
9. Land pattern tolerance is 0.15mm unless otherwise specified

Note: For the most current package drawings, please see the Microchip Packaging Specification located at <http://www.microchip.com/packaging>.

## Package Outlines and Dimensions

### TITLE

38 LEAD LGA 7x5 mm PACKAGE OUTLINE & RECOMMENDED LAND PATTERN

<b>DRAWING #</b>	LGA75-38LD-PL-1	<b>UNIT</b>	MM
------------------	-----------------	-------------	----

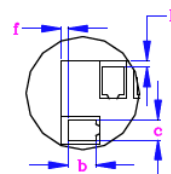
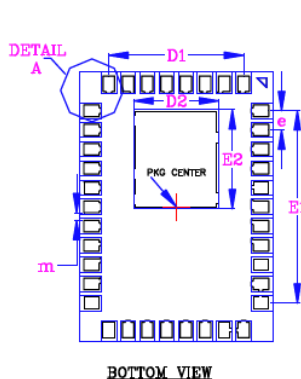
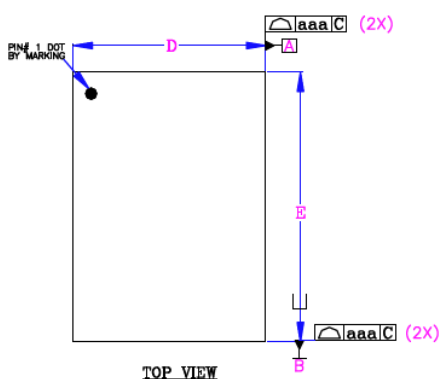

Dimensional Tol.	
aaa	0.100
bbb	0.070

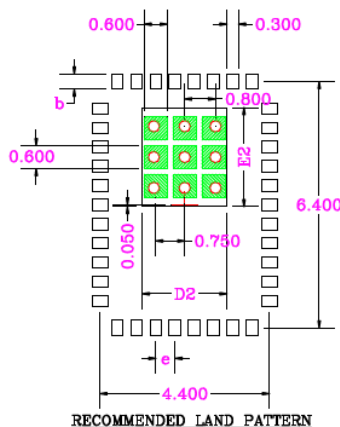
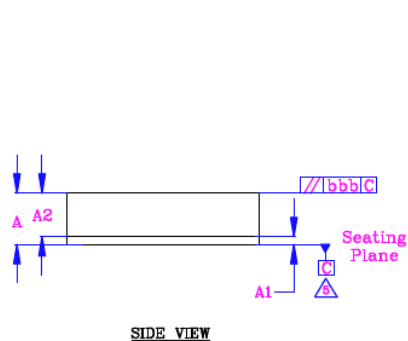

Dimensional Ref.			
REF.	Min.	Nom.	Max.
A	1.310	1.380	1.450
A1	0.240	0.280	0.320
A2	1.070	1.100	1.130
D	4.900	5.000	5.100
D1	3.500 BSC		
D2	2.100	2.200	2.300
E	6.900	7.000	7.100
E1	5.000 BSC		
E2	2.475	2.575	2.675
b	0.350	0.400	0.450
c	0.250	0.300	0.350
e	0.5000 BSC		
f	0.050	0.100	0.150
k	0.050	0.100	0.150
m	0.150	0.200	0.250
n	38		

### Notes:

- Dimensioning and Tolerancing per ASME Y14.5M-1994.
- Dimensions are in millimeters.
- 'e' represents the basic LGA pitch
- 'n' is the maximum no. of Land for a specified Package.
- Package warp shall be 0.050 max.
- Substrate base is BT Resin
- The Pin#1 corner must be identified on top side only.
- Reference JEDEC Spec M0-220.
- Red circles in land pattern indicate thermal via. Size should be 0.30mm in diameter. Pitch is 0.80mm and connected to GND for maximum thermal performance.
- Green rectangles (SHADED AREA) indicate solder stencil opening on exposed pad area. Size is 0.60x0.60mm. Pitch is 0.75mm
- Land Pattern Tolerance is  $\pm 0.02$ mm.

Note: For the most current package drawings, please see the Microchip Packaging Specification located at <http://www.microchip.com/packaging>.

**Package Outlines and Dimensions**

**TITLE**

76 LEAD LGA 5.5 x 5.5 mm PACKAGE OUTLINE & RECOMMENDED LAND PATTERN

<b>DRAWING #</b>	LGA5555-76LD-PL-1	<b>UNIT</b>	MM
------------------	-------------------	-------------	----

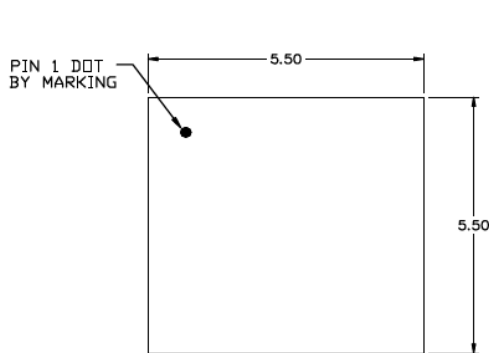

TOP VIEW  
NOTE: 1, 2, 3

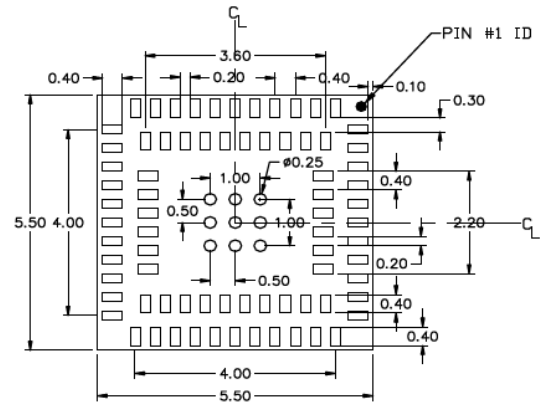

BOTTOM VIEW  
NOTE: 1, 2, 3

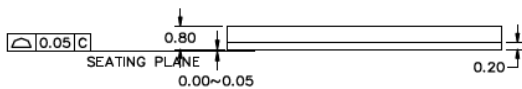

SIDE VIEW  
NOTE: 1, 2, 3

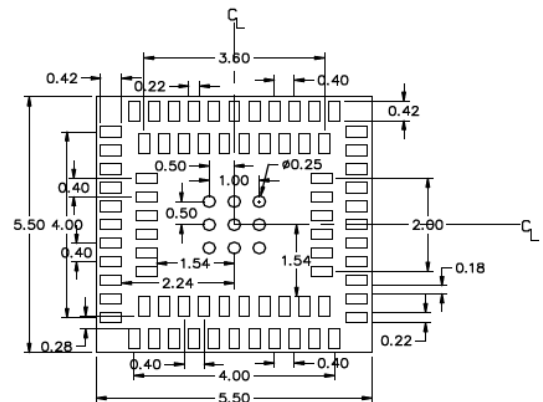

RECOMMENDED LAND PATTERN  
NOTE: 4

**NOTE:**

1. MAX PACKAGE WARPAGE IS 0.05 MM
2. MAX ALLOWABLE BURR IS 0.076MM IN ALL DIRECTIONS
3. PIN #1 IS ON TOP WILL BE LASER MARKED
4. RED CIRCLES IN LAND PATTERN REPRESENT THERMAL VIAS. RECOMMENDED SIZE IS 0.30-0.35MM AND SHOULD BE CONNECTED TO GND FOR MAXIMUM PERFORMANCE

Note: For the most current package drawings, please see the Microchip Packaging Specification located at <http://www.microchip.com/packaging>.



**MICROCHIP**

---

---

**Package Outlines and Dimensions**

---

---

**NOTES:**



---

---

**Package Outlines and Dimensions**

---

---

**LQFN**

Micrel Legacy

## Package Outlines and Dimensions

### TITLE

16 LEAD LQFN 3x3mm PACKAGE OUTLINE & RECOMMENDED LAND PATTERN

DRAWING #	LQFN33-16LD-PL-1	UNIT	MM
Lead Frame	Copper Alloy		

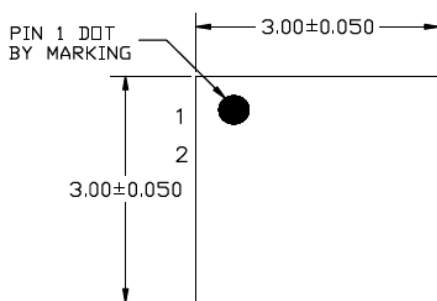

TOP VIEW  
NOTE: 1, 2, 3

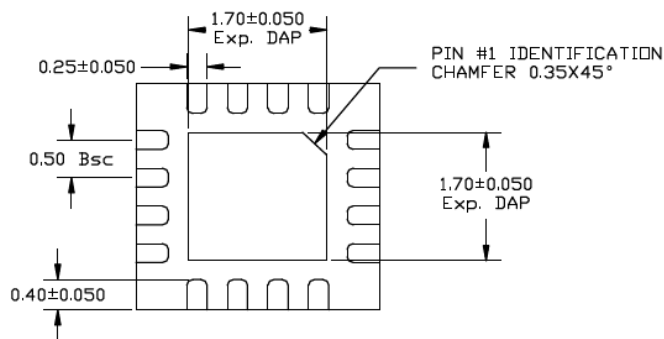

BOTTOM VIEW  
NOTE: 1, 2, 3

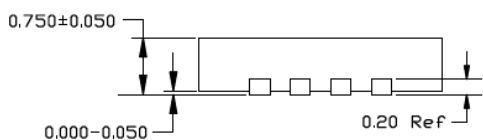

SIDE VIEW  
NOTE: 1, 2, 3

### NOTE:

1. MAX PACKAGE WARPAGE IS 0.05mm.
2. MAX ALLOWABLE BURR IS 0.076mm IN ALL DIRECTIONS
3. PIN #1 IS ON TOP WILL BE LASER MARKED.
4. RED CIRCLE IN LAND PATTERN INDICATES THERMAL VIA. SIZE SHOULD BE 0.30-0.35mm IN DIAMETER AND SHOULD BE CONNECTED TO GND FOR MAX THERMAL PERFORMANCE.
5. GREEN RECTANGLES (SHADED AREA) INDICATE SOLDER STENCIL OPENING ON EXPOSED PAD AREA. SIZE SHOULD BE 0.60x0.60mm IN SIZE, 0.20mm SPACING.

Note: For the most current package drawings, please see the Microchip Packaging Specification located at <http://www.microchip.com/packaging>.

**Package Outlines and Dimensions**

POD-Land Pattern Drawing #LQFN33-16LD-PL-1

RECOMMENDED LAND PATTERN

NOTE: 4, 5

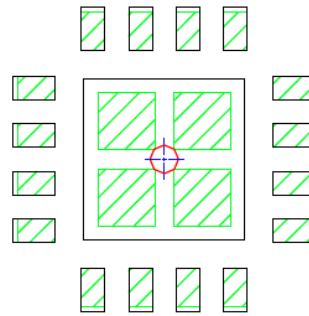

STACKED-UP

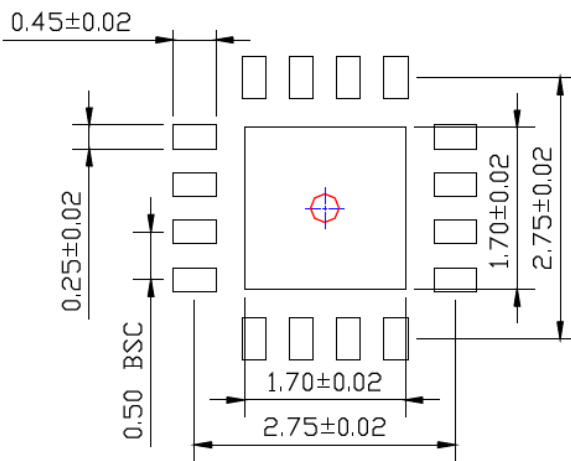

EXPOSED METAL TRACE

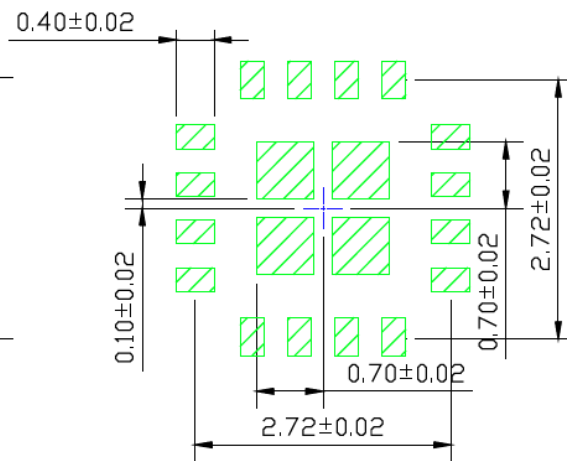

SOLDER STENCIL OPENING

Note: For the most current package drawings, please see the Microchip Packaging Specification located at <http://www.microchip.com/packaging>.



**MICROCHIP**

---

---

**Package Outlines and Dimensions**

---

---

NOTES:

---

---

**Package Outlines and Dimensions**

---

---

**LQFP**

Micrel Legacy

## Package Outlines and Dimensions

### TITLE

144/52/64 LEAD LQFP 10x10 mm PACKAGE OUTLINE & RECOMMENDED LAND PATTERN

<b>DRAWING #</b>	LQFP10x10-445264LD-PL-1	<b>UNIT</b>	MM
------------------	-------------------------	-------------	----

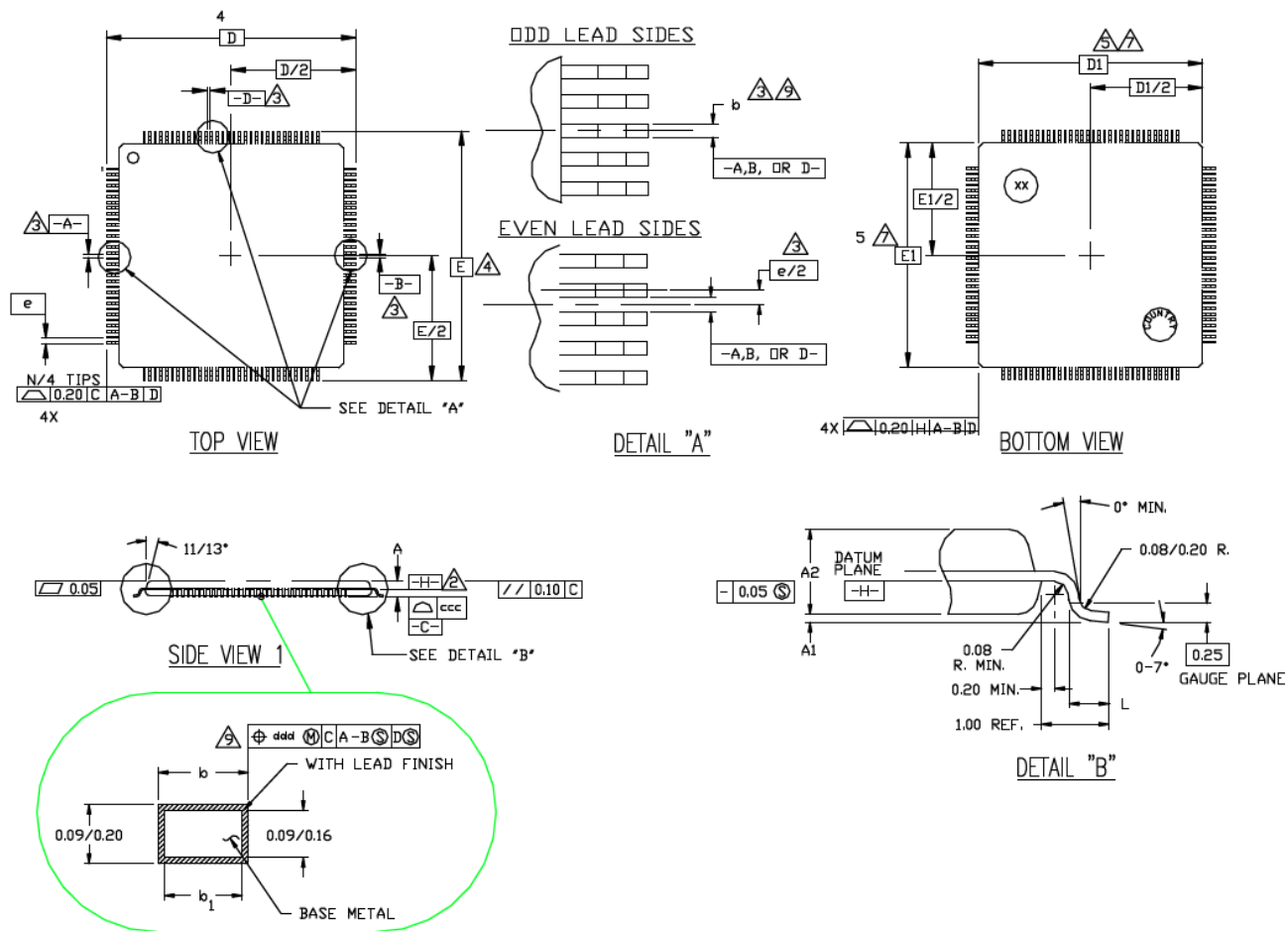

Note: For the most current package drawings, please see the Microchip Packaging Specification located at <http://www.microchip.com/packaging>.

## Package Outlines and Dimensions

### NOTES:

1. ALL DIMENSIONING AND TOLERANCING CONFORM TO ANSI Y14.5-1982.
2. DATUM PLANE  $\square\text{-H}\square$  LOCATED AT MOLD PARTING LINE AND COINCIDENT WITH LEAD, WHERE LEAD EXITS PLASTIC BODY AT BOTTOM OF PARTING LINE.
3. DATUMS  $\square\text{-A}\square$  AND  $\square\text{-D}\square$  TO BE DETERMINED AT CENTERLINE BETWEEN LEADS WHERE LEADS EXIT PLASTIC BODY AT DATUM PLANE  $\square\text{-H}\square$ .
4. TO BE DETERMINED AT SEATING PLANE  $\square\text{-C}\square$ .
5. DIMENSIONS D1 AND E1 DO NOT INCLUDE MOLD PROTRUSION. ALLOWABLE MOLD PROTRUSION IS 0.254 MM ON D1 AND E1 DIMENSIONS.
6. \*N\* IS THE TOTAL NUMBER OF TERMINALS.
7. THESE DIMENSIONS TO BE DETERMINED AT DATUM PLANE  $\square\text{-H}\square$ .
8. THE TOP OF PACKAGE IS SMALLER THAN THE BOTTOM OF PACKAGE BY 0.15 MILLIMETERS.
9. DIMENSION *b* DOES NOT INCLUDE DAMBAR PROTRUSION. ALLOWABLE DAMBAR PROTRUSION SHALL BE 0.08mm TOTAL IN EXCESS OF THE *b* DIMENSION AT MAXIMUM MATERIAL CONDITION. DAMBAR CANNOT BE LOCATED ON THE LOWER RADIUS OR THE FOOT.
10. CONTROLLING DIMENSION: MILLIMETER.
11. MAXIMUM ALLOWABLE DIE THICKNESS TO BE ASSEMBLED IN THIS PACKAGE FAMILY IS 0.38 MILLIMETERS.
12. THIS OUTLINE CONFORMS TO JEDEC PUBLICATION 95 REGISTRATION MS-026, VARIATIONS BCB, BCC, BCD & BCE.  $\square\text{-A1}\square$  IS DEFINED AS THE DISTANCE FROM THE SEATING PLANE TO THE LOWEST POINT OF THE PACKAGE BODY.

N	JEDEC VARIATION ALL DIMENSIONS IN MILLIMETERS			N D I E
	MIN.	NOM.	MAX.	
A	~	~	1.60	13
A1	0.05	~	0.15	
A2	1.35	1.40	1.45	
D	~	12.00 BSC.	~	4
D1	~	10.00 BSC.	~	7.8
E	~	12.00 BSC.	~	4
E1	~	10.00 BSC.	~	7.8
L	0.45	0.60	0.75	9
e	~	0.80 BSC.	~	
b	0.30	0.37	0.45	
b1	0.30	0.35	0.40	9
ccc	~	~	0.10	
ddd	~	~	0.20	

N	JEDEC VARIATION ALL DIMENSIONS IN MILLIMETERS			N D I E
	MIN.	NOM.	MAX.	
A	~	~	1.60	13
A1	0.05	~	0.15	
A2	1.35	1.40	1.45	
D	~	12.00 BSC.	~	4
D1	~	10.00 BSC.	~	7.8
E	~	12.00 BSC.	~	4
E1	~	10.00 BSC.	~	7.8
L	0.45	0.60	0.75	9
e	~	0.65 BSC.	~	
b	0.22	0.32	0.38	
b1	0.22	0.30	0.33	9
ccc	~	~	0.10	
ddd	~	~	0.13	

N	JEDEC VARIATION ALL DIMENSIONS IN MILLIMETERS			N D I E
	MIN.	NOM.	MAX.	
A	~	~	1.60	13
A1	0.05	~	0.15	
A2	1.35	1.40	1.45	
D	~	12.00 BSC.	~	4
D1	~	10.00 BSC.	~	7.8
E	~	12.00 BSC.	~	4
E1	~	10.00 BSC.	~	7.8
L	0.45	0.60	0.75	9
e	~	0.50 BSC.	~	
b	0.17	0.22	0.27	
b1	0.17	0.20	0.23	9
ccc	~	~	0.08	
ddd	~	~	0.08	

Note: For the most current package drawings, please see the Microchip Packaging Specification located at <http://www.microchip.com/packaging>.

**Package Outlines and Dimensions**

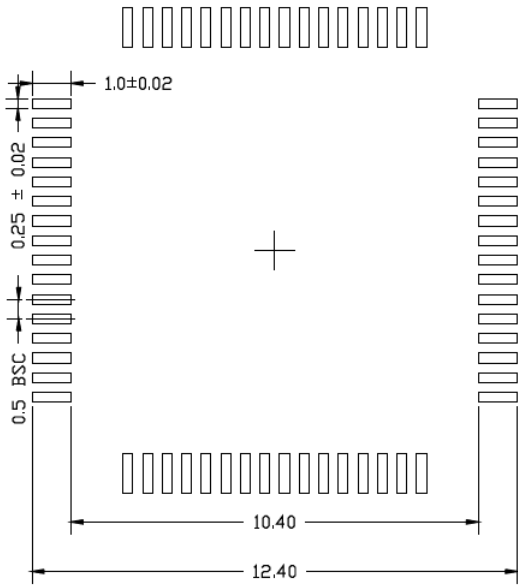

LQFP 10x10mm 64LD

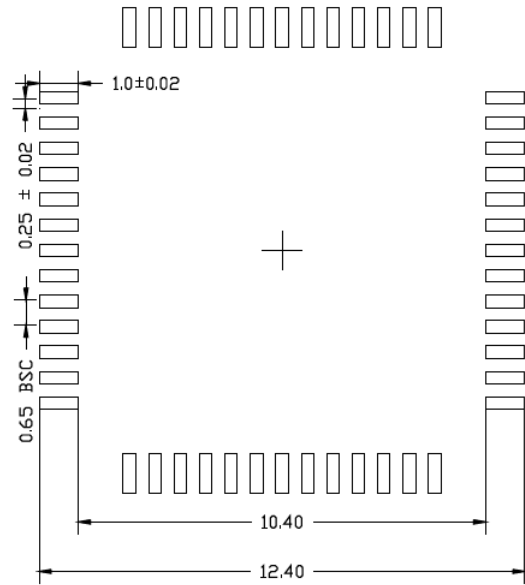

LQFP 10x10mm 52LD

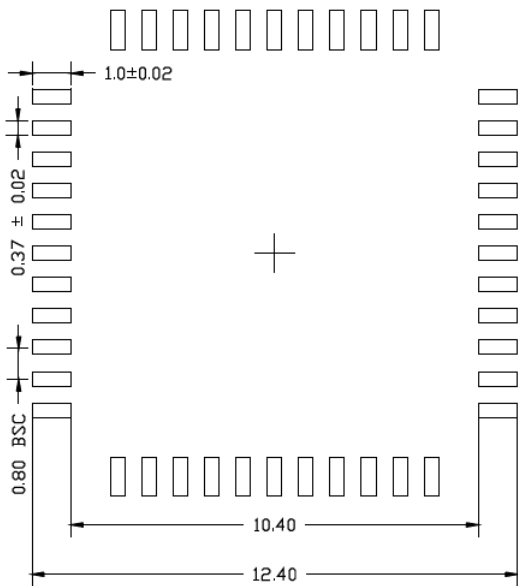

LQFP 10x10mm 44LD

RECOMMENDED LAND PATTERN

Note: For the most current package drawings, please see the Microchip Packaging Specification located at <http://www.microchip.com/packaging>.



**Package Outlines and Dimensions**

**TITLE**

48 LEAD LQFP 7x7mm PACKAGE OUTLINE & RECOMMENDED LAND PATTERN

<b>DRAWING #</b>	LQFP7x7-48LD-PL-1	<b>UNIT</b>	MM [INCHES]
------------------	-------------------	-------------	-------------

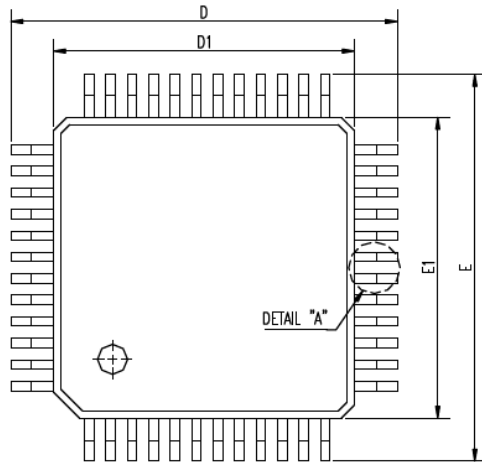

SYMBOL	DIMENSION IN MM			DIMENSION IN INCH		
	MIN.	NOM	MAX.	MIN.	NOM	MAX.
A			1.60			0.063
A1	0.05		0.15	0.002		0.006
A2	1.35	1.40	1.45	0.053	0.055	0.057
D	8.90	9.00	9.10	0.350	0.354	0.358
D1	6.90	7.00	7.10	0.272	0.276	0.280
E	8.90	9.00	9.10	0.350	0.354	0.358
E1	6.90	7.00	7.10	0.272	0.276	0.280
c	0.178 TYP.			0.007 TYP.		
c1	0.127 TYP.			0.005 TYP.		
L	0.50	0.60	0.70	0.020	0.024	0.028
L1	1.00 REF.			0.039 REF.		
Ø	0	3.5	7	0	3.5	7
JEDEC						

N	b (MM)			b1 (MM)			e (MM)			JEDEC
	MIN.	NOM	MAX.	MIN.	NOM	MAX.	MIN.	NOM	MAX.	
48L	0.19	0.22	0.25	0.17	0.20	0.23	0.50 BSC.			

TOP VIEW

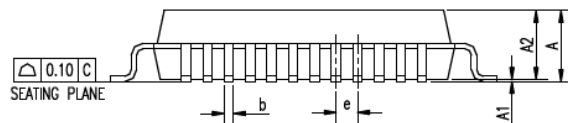

SIDE VIEW 1

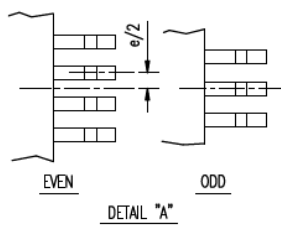
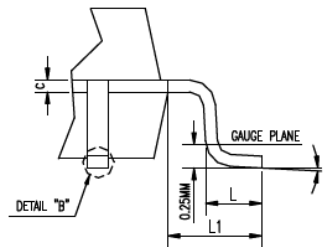

DETAIL "A"

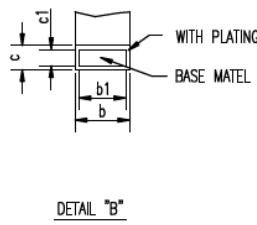

DETAIL "B"

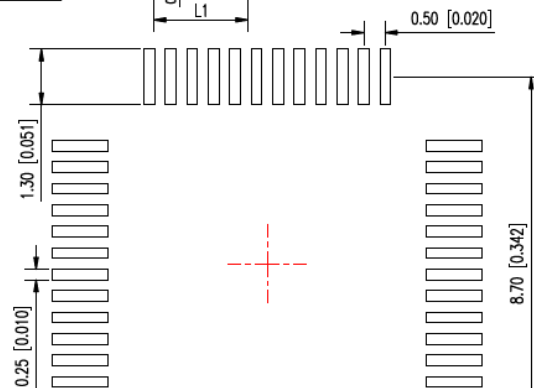

RECOMMENDED LAND PATTERN

**NOTES:**

1. ALL DIMENSIONS ARE IN MM [INCHES].
2. CONTROLLING DIMENSION : MM.

Note: For the most current package drawings, please see the Microchip Packaging Specification located at <http://www.microchip.com/packaging>.

## Package Outlines and Dimensions

### TITLE

48 LEAD LQFP 7x7mm PACKAGE OUTLINE & RECOMMENDED LAND PATTERN

<b>DRAWING #</b>	LQFP7x7-48LD-PL-5	<b>UNIT</b>	MM [INCHES]
<b>Lead Frame</b>	Copper Alloy	<b>Lead Finish</b>	Matte Tin

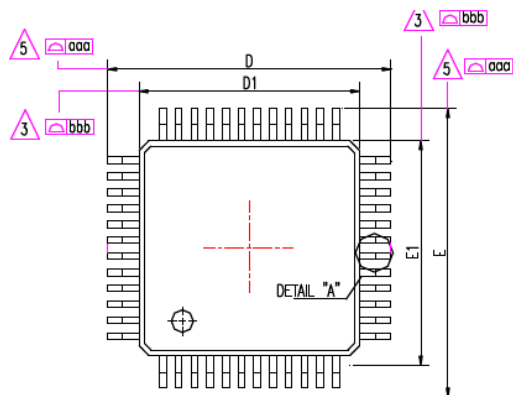

TOP VIEW

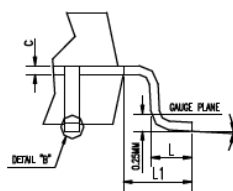

SIDE VIEW 1

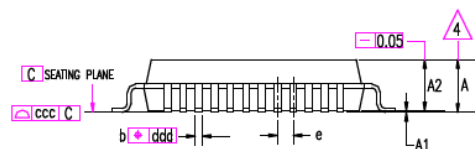

SIDE VIEW 2

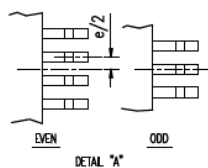

DETAIL "A"

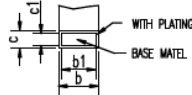

DETAIL "B"

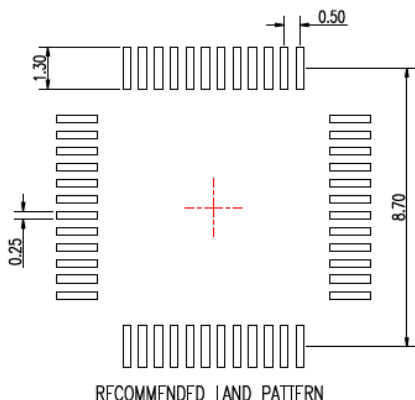

RECOMMENDED LAND PATTERN

SYMBOL	DIMENSION IN MM		
	MIN.	NOM.	MAX.
A	-	-	1.60
A1	0.05	-	0.15
A2	1.35	1.40	1.45
D	9.00 BSC		
D1	7.00 BSC		
E	9.00 BSC		
E1	7.00 BSC		
c	0.09	-	0.20
c1	0.09	-	0.16
L	0.45	0.60	0.75
L1	1.00 REF.		
θ	0	3.5	7

N	b (MM)			b1 (MM)			e (MM)		
	MIN.	NOM.	MAX.	MIN.	NOM.	MAX.	MIN.	NOM.	MAX.
48L	0.17	0.22	0.27	0.17	0.20	0.23	0.50 BSC.		

TOLERANCE OF FORM AND POSITION	
aaa	0.20
bbb	0.20
ccc	0.08
ddd	0.08

#### NOTES:

- ALL DIMENSIONS ARE IN MM.
- REFER TO JEDEC STANDARD MS-026 BBC.
- DIMENSIONS "D1" AND "E1" DO NOT INCLUDE MOLD PROTRUSIONS. ALLOWABLE PROTRUSION IS 0.25mm PER SIDE. "D1" AND "E1" ARE MAXIMUM PLASTIC BODY SIZE DIMENSIONS INCLUDING MOLD MISMATCH.
- A1 IS DEFINED AS THE DISTANCE FROM THE SEATING PLANE TO THE LOWEST POINT OF THE PACKAGE BODY. TO BE DETERMINED AT SEATING DATUM PLANE C.
- "aaa" IS THE BILATERAL PROFILE TOLERANCE THAT CONTROLS THE POSITION OF THE PLASTIC BODY SIDES. THE CENTER OF THE PROFILE ZONES ARE DEFINED BY THE BASIC DIMENSIONS "D" AND "E".
- "bbb" THE TOLERANCE THAT CONTROLS THE POSITION OF THE ENTIRE TERMINAL PATTERN WITH RESPECT TO DATUM'S A AND B. THE CENTER OF THE TOLERANCE ZONE FOR EACH TERMINAL IS DEFINED BY THE BASIC DIMENSION "e" RELATED TO DATUM A AND B.
- "ccc" THE TOLERANCE RELATED TO THE SEATING PLANE IN WHICH THE TOP SURFACE OF THE PACKAGE MUST BE LOCATED.
- "ddd" THE TOLERANCE THAT CONTROLS THE POSITION OF THE TERMINALS TO EACH OTHER. THE CENTER OF THE PROFILE ZONES ARE DETERMINED BY THE BASIC DIMENSION "e".
- THIS DOCUMENT IS FOR AUTOMOTIVE PRODUCT USE ONLY.

Note: For the most current package drawings, please see the Microchip Packaging Specification located at <http://www.microchip.com/packaging>.

## Package Outlines and Dimensions

**TITLE**

64 LEAD LQFP 7x7mm PACKAGE OUTLINE &amp; RECOMMENDED LAND PATTERN

<b>DRAWING #</b>	LQFP7x7-64LD-PL-817	<b>UNIT</b>	MM [INCHES]
------------------	---------------------	-------------	-------------

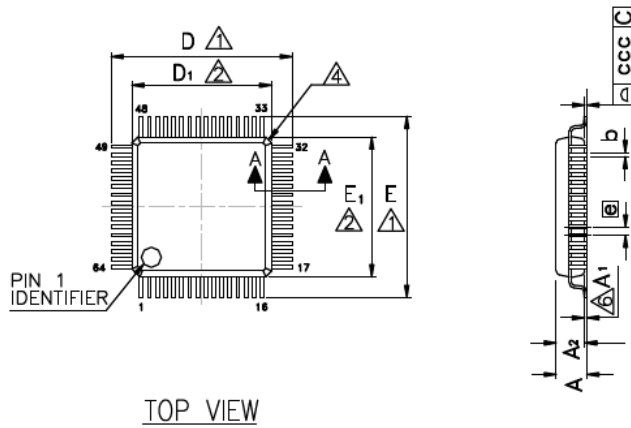

TOP VIEW

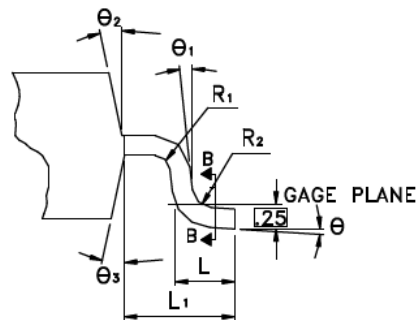

SECTION A-A

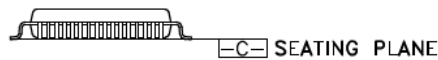

SIDE VIEW

Symbol	Dimension in mm			Dimension in inch		
	Min	Nom	Max	Min	Nom	Max
A	—	—	1.60	—	—	0.063
A <sub>1</sub>	0.05	—	0.15	0.002	—	0.006
A <sub>2</sub>	1.35	1.40	1.45	0.053	0.055	0.057
b	0.13	0.18	0.23	0.005	0.007	0.009
b <sub>1</sub>	0.13	0.16	0.19	0.005	0.006	0.007
c	0.09	—	0.20	0.004	—	0.008
c <sub>1</sub>	0.09	—	0.16	0.004	—	0.006
D	9.00 BSC			0.354 BSC		
D <sub>1</sub>	7.00 BSC			0.276 BSC		
E	9.00 BSC			0.354 BSC		
E <sub>1</sub>	7.00 BSC			0.276 BSC		
⊞	0.40 BSC			0.016 BSC		
L	0.45	0.60	0.75	0.018	0.024	0.030
L <sub>1</sub>	1.00 REF			0.039 REF		
R <sub>1</sub>	0.08	—	—	0.003	—	—
R <sub>2</sub>	0.08	—	0.20	0.003	—	0.008
θ	0°	3.5°	7°	0°	3.5°	7°
θ <sub>1</sub>	0°	—	—	0°	—	—
θ <sub>2</sub>	11°	12°	13°	11°	12°	13°
θ <sub>3</sub>	11°	12°	13°	11°	12°	13°
ccc	0.08			0.003		

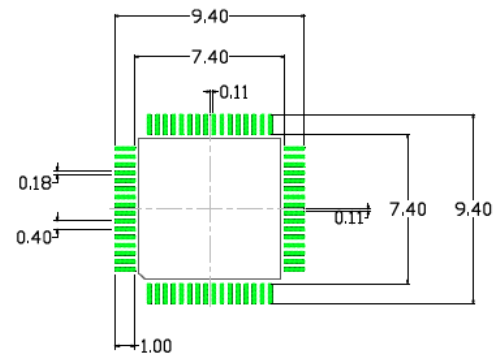

RECOMMENDED LAND PATTERN

**NOTE:**

1. DIMENSIONS ARE IN MM [INCHES].
2. CONTROLLING DIMENSION: MM.
3. DIMENSION DOES NOT INCLUDE MOLD FLASH OF 0.254[0.010] MAX.
4. MAXIMUM AND MINIMUM SPECIFICATIONS ARE INDICATED AS FOLLOWS: MAX
5. THIS DIMENSION INCLUDES LEAD FINISH.
6. RECOMMENDED LAND PATETRN TOLERANCE IS ±0.02mm UNLESS SPECIFIED.

Note: For the most current package drawings, please see the Microchip Packaging Specification located at <http://www.microchip.com/packaging>.

## Package Outlines and Dimensions

### TITLE

64 LEAD LQFP 10x10mm PACKAGE OUTLINE & RECOMMENDED LAND PATTERN

<b>DRAWING #</b>	LQFP10x10-64LD-PL-1	<b>UNIT</b>	MM
------------------	---------------------	-------------	----

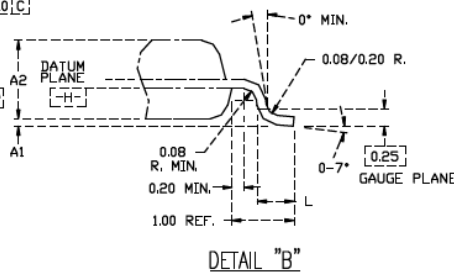
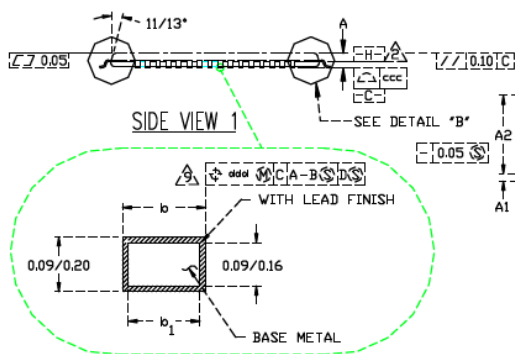
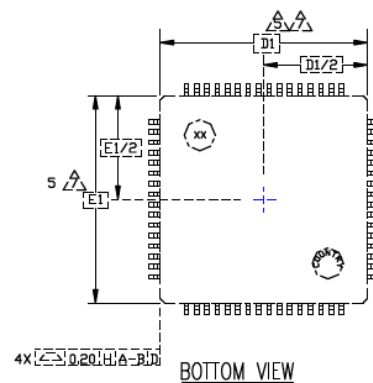
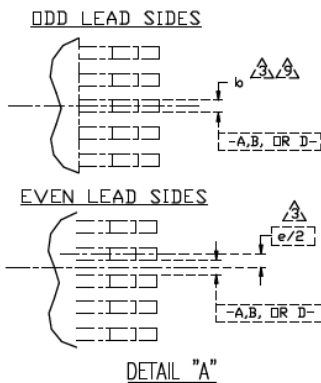
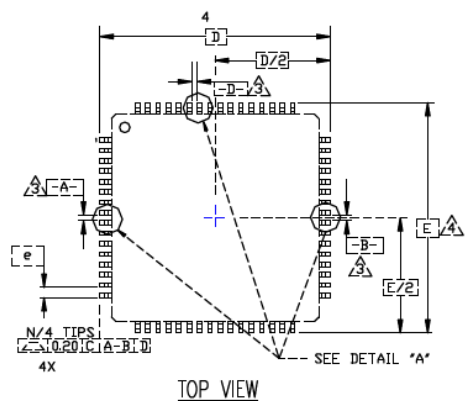

JEDEC VARIATION ALL DIMENSIONS IN MILLIMETERS				
N	64			N T E
	MIN.	NDM.	MAX.	
A	0.05		0.15	13
A <sub>2</sub>	1.35	1.40	1.45	
D	12.00 BSC.			4
D <sub>1</sub>	10.00 BSC.			7,8
E	12.00 BSC.			4
E <sub>1</sub>	10.00 BSC.			7,8
L	0.45	0.60	0.75	9
e	0.50 BSC.			
b	0.17	0.22	0.27	
b <sub>1</sub>	0.17	0.20	0.23	
ccc			0.08	
ddd			0.08	

### NOTES:

- ALL DIMENSIONING AND TOLERANCING CONFORM TO ANSI Y14.5-1982.
- DATUM PLANE [H] LOCATED AT MOLD PARTING LINE AND COINCIDENT WITH LEAD, WHERE LEAD EXITS PLASTIC BODY AT BOTTOM OF PARTING LINE.
- DATUMS [A-B] AND [E] TO BE DETERMINED AT CENTERLINE BETWEEN LEADS WHERE LEADS EXIT PLASTIC BODY AT DATUM PLANE [H].
- TO BE DETERMINED AT SEATING PLANE [E].
- DIMENSIONS D<sub>1</sub> AND E<sub>1</sub> DO NOT INCLUDE MOLD PROTRUSION. ALLOWABLE MOLD PROTRUSION IS 0.254 MM ON D<sub>1</sub> AND E<sub>1</sub> DIMENSIONS.
- \*N\* IS THE TOTAL NUMBER OF TERMINALS.
- THESE DIMENSIONS TO BE DETERMINED AT DATUM PLANE [H].
- THE TOP OF PACKAGE IS SMALLER THAN THE BOTTOM OF PACKAGE BY 0.15 MILLIMETERS.
- DIMENSION b DOES NOT INCLUDE DAMBAR PROTRUSION. ALLOWABLE DAMBAR PROTRUSION SHALL BE 0.08mm TOTAL IN EXCESS OF THE b DIMENSION AT MAXIMUM MATERIAL CONDITION. DAMBAR CANNOT BE LOCATED ON THE LOWER RADIUS OR THE FOOT.
- CONTROLLING DIMENSION: MILLIMETER.
- MAXIMUM ALLOWABLE DIE THICKNESS TO BE ASSEMBLED IN THIS PACKAGE FAMILY IS 0.38 MILLIMETERS.
- THIS OUTLINE CONFORMS TO JEDEC PUBLICATION 95 REGISTRATION MS-026, VARIATIONS BCB, BCC, BCD & BCE.
- A<sub>1</sub> IS DEFINED AS THE DISTANCE FROM THE SEATING PLANE TO THE LOWEST POINT OF THE PACKAGE BODY.

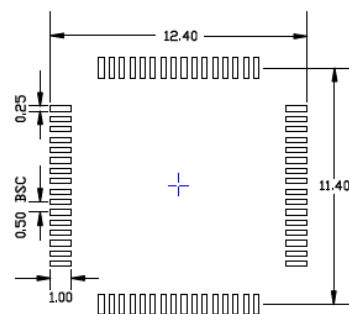

Note: For the most current package drawings, please see the Microchip Packaging Specification located at <http://www.microchip.com/packaging>.

**Package Outlines and Dimensions**

**TITLE**

64 LEAD LQFP 10X10 mm EPAD PACKAGE OUTLINE & RECOMMENDED LAND PATTERN

<b>DRAWING #</b>	LQFPEP10X10-64LD-PL-1	<b>UNIT</b>	MM [INCH]
------------------	-----------------------	-------------	-----------

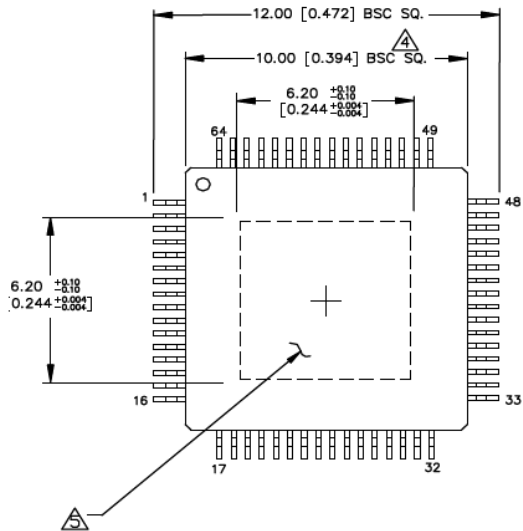

TOP/BOTTOM VIEW

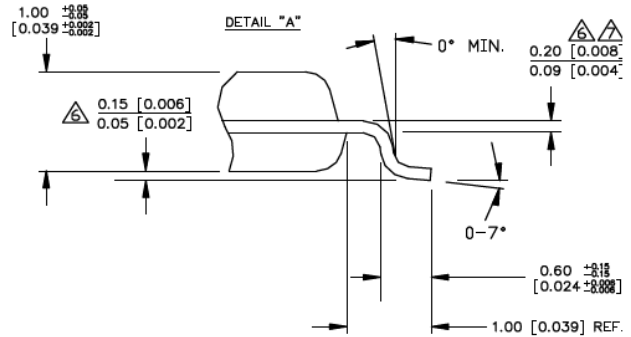

DETAIL VIEW

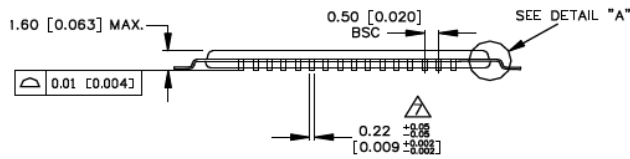

SIDE VIEW

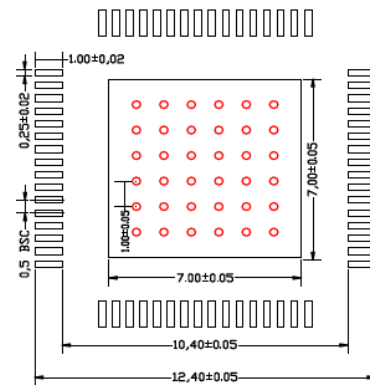

RECOMMENDED LAND PATTERN

**NOTES:**

1. DIMENSIONS ARE IN MM[INCHES].
2. CONTROLLING DIMENSION: MM.
3. EXPOSED PAD: Cu WITH Sn PLATING.
4. DIMENSION DOES NOT INCLUDE MOLD FLASH OF 0.25[0.010] MAX.
5. DIE UP ORIENTATION SHOWN. EXPOSED PAD IS VISIBLE FROM BOTTOM OF PACKAGE.
6. MAXIMUM AND MINIMUM SPECIFICATIONS ARE INDICATED AS FOLLOWS:  $\frac{\text{MAX}}{\text{MIN}}$
7. THIS DIMENSION INCLUDES LEAD FINISH.
8. RED CIRCLES IN LAND PATTERN REPRESENT THERMAL VIAS. SIZE IS 0.30MM AND SHOULD BE CONNECTED TO GND FOR MAXIMUM PERFORMANCE

Note: For the most current package drawings, please see the Microchip Packaging Specification located at <http://www.microchip.com/packaging>.

## Package Outlines and Dimensions

### TITLE

80 LEAD LQFP 10x10mm PACKAGE OUTLINE & RECOMMENDED LAND PATTERN

<b>DRAWING #</b>	LQFP10x10-80LD-PL-1	<b>UNIT</b>	MM
------------------	---------------------	-------------	----

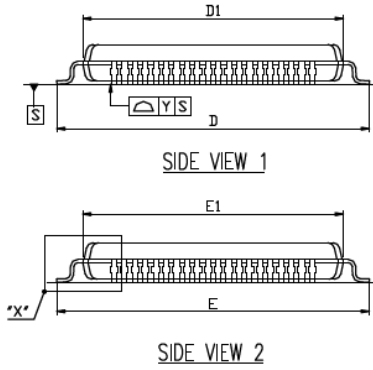
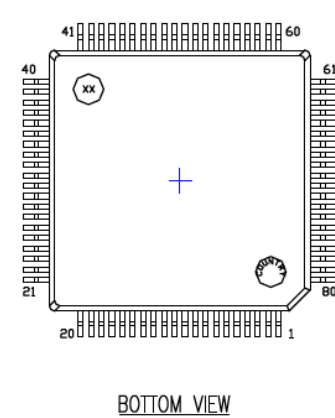
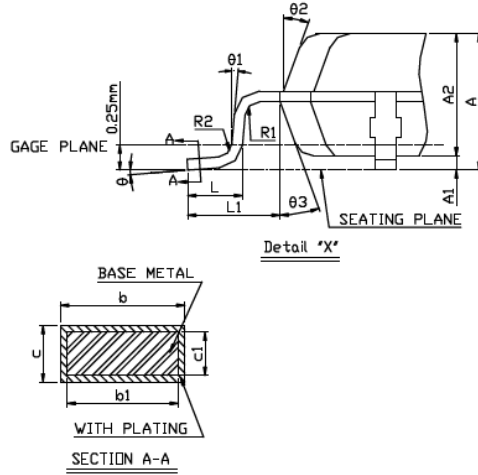
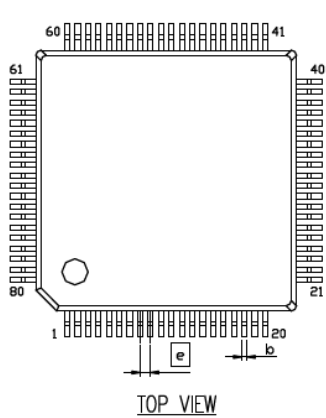

SYMBOL	DIMENSION (MM)			DIMENSION (MIL)		
	MIN.	NOM.	MAX.	MIN.	NOM.	MAX.
A			1.60			63
A1	0.05		0.15	2		6
A2	1.35	1.40	1.45	53	55	57
b	0.13	0.18	0.23	5	7	9
b1	0.13	0.16	0.19	5	6	7
c	0.09		0.20	4		8
c1	0.09		0.16	4		6
D	11.90	12.00	12.10	368	472	476
D1	9.90	10.00	10.10	390	394	398
E	11.90	12.00	12.10	368	472	476
E1	9.90	10.00	10.10	390	394	398
E	0.40 BSC			16 BSC		
L	0.45	0.60	0.75	18	24	30
L1	1.00 REF			39 REF		
R1	0.08			3		
R2	0.08		0.20	3		8
Y			0.08			3
θ	0°	3.5°	7°	0°	3.5°	7°
θ1	0°			0°		
θ2	11°	12°	13°	11°	12°	13°
θ3	11°	12°	13°	11°	12°	13°

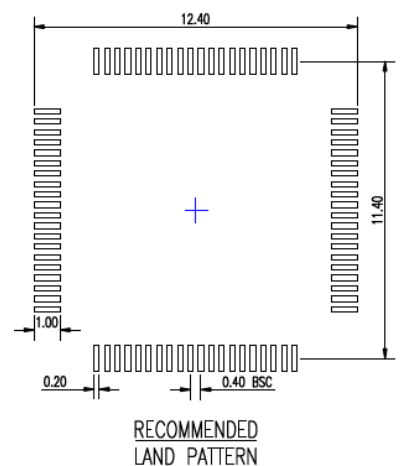

- NOTES:**
1. REFER TO JEDEC MS-026 (ISSUE D) / BCE
  2. DIMENSION D1 AND E1 DO NOT INCLUDE MOLD PROTRUSION. ALLOWABLE PROTRUSION IS 0.25mm PER SIDE. D1 AND E1 ARE MAXIMUM PLASTIC BODY SIZE DIMENSION INCLUDING MOLD MISMATCH.
  3. DIMENSION b DOES NOT INCLUDE DAMBAR PROTRUSION. ALLOWABLE DAMBAR PROTRUSION SHALL NOT CAUSE THE LEAD WIDTH TO EXCEED THE MAXIMUM b DIMENSION BY MORE THAN 0.08mm.
  4. ALL DIMENSIONS IN MILLIMETERS.

Note: For the most current package drawings, please see the Microchip Packaging Specification located at <http://www.microchip.com/packaging>.

## Package Outlines and Dimensions

**TITLE**

100 LEAD LQFP 12x12mm PACKAGE OUTLINE &amp; RECOMMENDED LAND PATTERN

**DRAWING #** LQFP12x12-100LD-PL-86

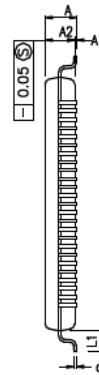
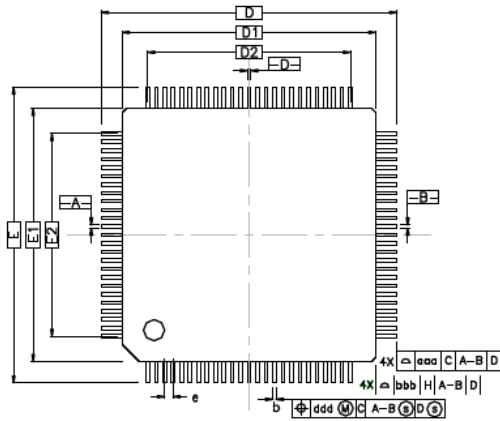
**UNIT** MM [INCHES]

SYMBOL	MILLIMETER			INCH		
	MIN.	NOM.	MAX.	MIN.	NOM.	MAX.
A	—	—	1.60	—	—	0.063
A1	0.05	—	0.15	0.002	—	0.006
A2	1.35	1.40	1.45	0.053	0.055	0.057
D	14.00 BSC.			0.551 BSC.		
D1	12.00 BSC.			0.472 BSC.		
E	14.00 BSC.			0.551 BSC.		
E1	12.00 BSC.			0.472 BSC.		
R2	0.08	—	0.20	0.003	—	0.008
R1	0.08	—	—	0.003	—	—
θ	0°	3.5°	7°	0°	3.5°	7°
θ <sub>1</sub>	0°	—	—	0°	—	—
θ <sub>2</sub>	11°	12°	13°	11°	12°	13°
θ <sub>3</sub>	11°	12°	13°	11°	12°	13°
c	0.09	—	0.20	0.004	—	0.008
L	0.45	0.60	0.75	0.018	0.024	0.030
L <sub>1</sub>	1.00 REF.			0.039 REF.		
S	0.20	—	—	0.008	—	—
b	0.13	0.16	0.23	0.005	0.006	0.009
e	0.40 BSC.			0.016 BSC.		
TOLERANCES OF FORM AND POSITION						
aaa	0.20		0.008			
bbb	0.20		0.008			
ccc	0.08		0.003			
ddd	0.08		0.003			

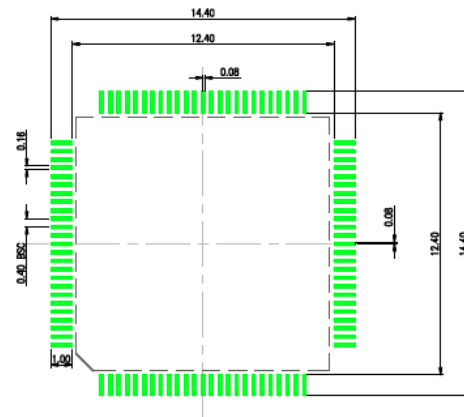
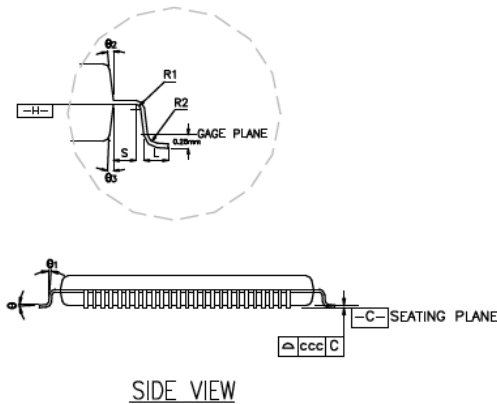
**NOTE:**

1. DIMENSIONS ARE IN MM [INCHES].
2. CONTROLLING DIMENSION: MM.
3. DIMENSION DOES NOT INCLUDE MOLD FLASH OF 0.254[0.010] MAX.
4. MAXIMUM AND MINIMUM SPECIFICATIONS ARE INDICATED AS FOLLOWS: MAX
5. THIS DIMENSION INCLUDES LEAD FINISH.
6. RECOMMENDED LAND PATETRN TOLERANCE IS ±0.02mm UNLESS SPECIFIED.

Note: For the most current package drawings, please see the Microchip Packaging Specification located at <http://www.microchip.com/packaging>.

## Package Outlines and Dimensions

### TITLE

128 LEAD LQFP 14x14mm PACKAGE OUTLINE & RECOMMENDED LAND PATTERN

<b>DRAWING #</b>	LQFP14x14-128LD-PL-1	<b>UNIT</b>	MM [INCHES]
------------------	----------------------	-------------	-------------

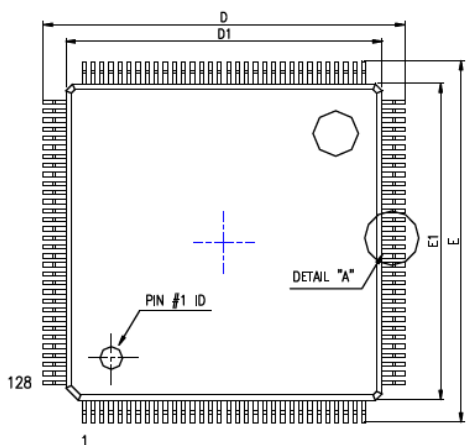

TOP VIEW

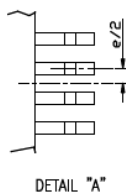

DETAIL "A"

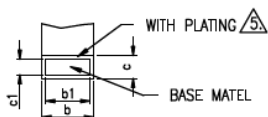

DETAIL "B"

DETAIL VIEW

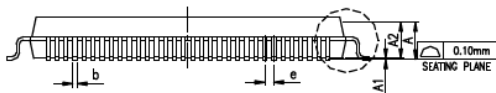

SIDE VIEW

**NOTES:**

1. DIMENSIONS ARE IN MM [INCHES].
2. CONTROLLING DIMENSION: MM.
- ⚠ DIMENSION DOES NOT INCLUDE MOLD FLASH OF 0.254[0.010] MAX.
- ⚠ MAXIMUM AND MINIMUM SPECIFICATIONS ARE INDICATED AS FOLLOWS: MAX
- ⚠ THIS DIMENSION INCLUDES LEAD FINISH.

SYMBOL	DIMENSION IN MM			DIMENSION IN INCH		
	MIN.	NOM	MAX.	MIN.	NOM	MAX.
A			1.60			0.063
A1	0.05		0.15	0.002		0.006
A2	1.35	1.40	1.45	0.053	0.055	0.057
D	15.90	16.00	16.10	0.626	0.630	0.634
D1	13.90	14.00	14.10	0.547	0.551	0.555
E	15.90	16.00	16.10	0.626	0.630	0.634
E1	13.90	14.00	14.10	0.547	0.551	0.555
c	0.178			0.007		
c1	0.127 BSC.			0.005 BSC.		
L	0.45	0.60	0.75	0.018	0.024	0.030
L1	1.00 REF.			0.039 REF.		
⊖	0	3.5	7	0	3.5	7
b	0.15	0.18	0.21	0.006	0.007	0.008
b1	0.13	0.16	0.19	0.005	0.006	0.007
e	0.40 BSC.			0.016 BSC.		

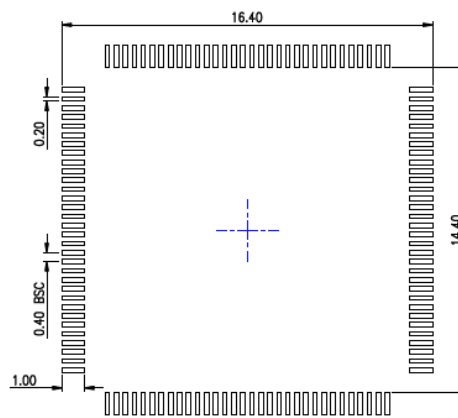
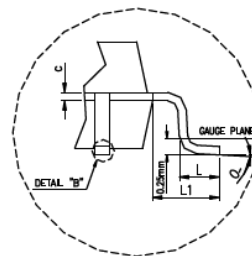

RECOMMENDED LAND PATTERN

Note: For the most current package drawings, please see the Microchip Packaging Specification located at <http://www.microchip.com/packaging>.



## Package Outlines and Dimensions

**TITLE**

176 LEAD LQFP 20x20mm PACKAGE OUTLINE & RECOMMENDED LAND PATTERN

<b>DRAWING #</b>	LQFP20x20-176LD-PL-1	<b>UNIT</b>	MM/ INCH
------------------	----------------------	-------------	----------

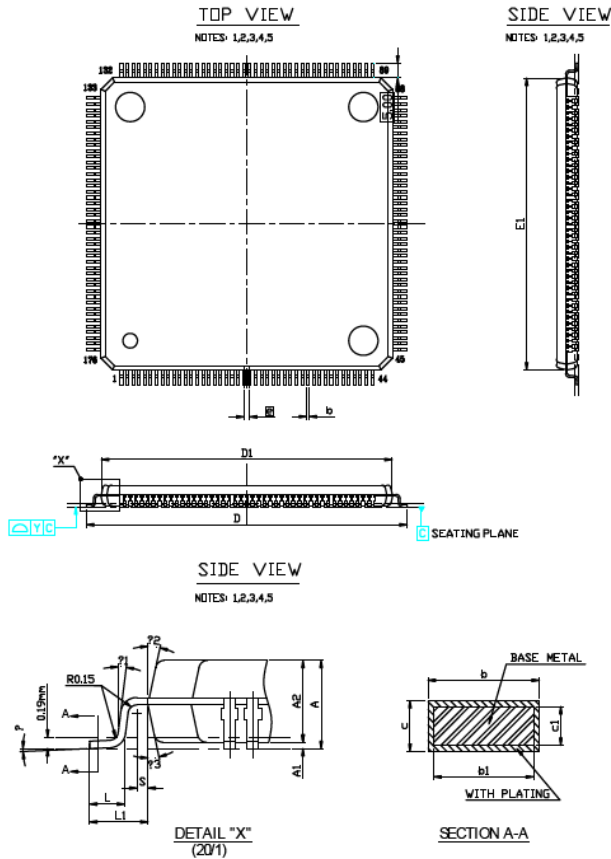

SYMBOL	DIMENSION (MM)			DIMENSION (MIL)		
	MIN.	NDM.	MAX.	MIN.	NDM.	MAX.
A	—	—	1.60	—	—	62.99
A1	0.05	—	0.15	1.97	—	5.91
A2	1.35	1.40	1.45	53.15	55.12	57.69
b	0.13	0.18	0.23	5.12	7.09	9.06
b1	0.13	0.16	0.19	5.12	6.30	7.48
c	0.09	—	0.20	3.54	—	7.87
c1	0.09	—	0.16	3.54	—	6.30
D	21.90	22.00	22.10	862.20	866.14	870.08
D1	19.90	20.00	20.10	783.46	787.40	791.34
E	21.90	22.00	22.10	862.20	866.14	870.08
E1	19.90	20.00	20.10	783.46	787.40	791.34
⌀	0.40 BSC			15.75 BSC		
L	0.45	0.60	0.75	17.72	23.62	29.53
L1	1.00 REF			39.37 REF		
R1	0.08	—	—	3.15	—	—
R2	0.08	—	0.20	3.15	—	7.87
Y	—	—	0.075	—	—	2.95
θ	0°	3.5°	7°	0°	3.5°	7°
θ1	0°	—	—	0°	—	—
θ2	11°	12°	13°	11°	12°	13°
θ3	11°	12°	13°	11°	12°	13°
S	0.20	—	—	7.87	—	—

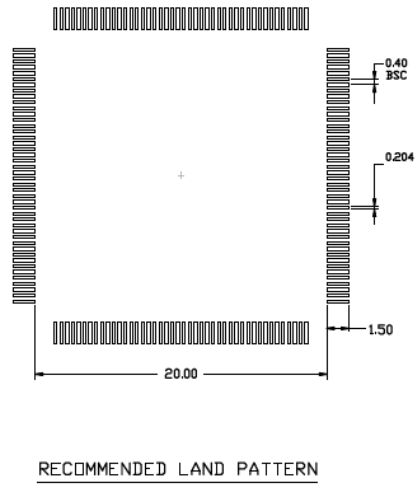

- NOTES:
1. REFER TO JEDEC MS-026/BFC REV. D
  2. DIMENSION D1 AND E1 DO NOT INCLUDE MOLD PROTRUSION. ALLOWABLE PROTRUSION IS 0.25mm PER SIDE. D1 AND E1 ARE MAXIMUM PLASTIC BODY SIZE DIMENSION INCLUDING MOLD MISMATCH.
  3. DIMENSION b DOES NOT INCLUDE DAMBAR PROTRUSION. ALLOWABLE DAMBAR PROTRUSION SHALL NOT CAUSE THE LEAD WIDTH TO EXCEED THE MAXIMUM b DIMENSION BY MORE THAN 0.08mm.
  4. ALL DIMENSIONS IN MILLIMETERS.
  5. MODIFIED MIL DIMENSION, ADD TWO DECIMALS FOR CUSTOMER MANUFACTURE USE
  6. LAND PATTERN UNIT OF MEASUREMENT IN MM.

Note: For the most current package drawings, please see the Microchip Packaging Specification located at <http://www.microchip.com/packaging>.



**MICROCHIP**

---

---

**Package Outlines and Dimensions**

---

---

NOTES:

---

---

**Package Outlines and Dimensions**

---

---

**MSOP**

Micrel Legacy

## Package Outlines and Dimensions

### TITLE

8 LEAD MSOP PACKAGE OUTLINE & RECOMMENDED LAND PATTERN

DRAWING #	MSOP-8LD-PL-1	UNIT	INCH [MM]
-----------	---------------	------	-----------

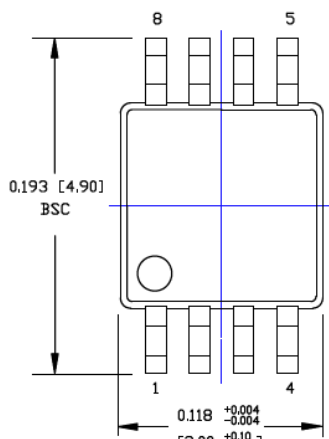

TOP VIEW

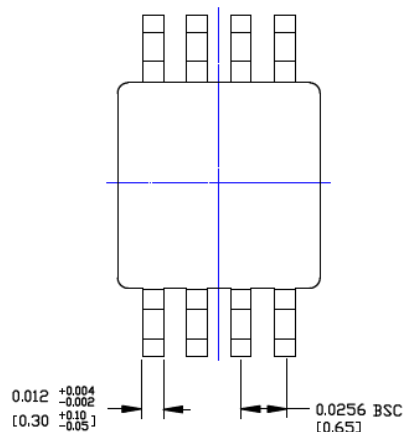

BOTTOM VIEW

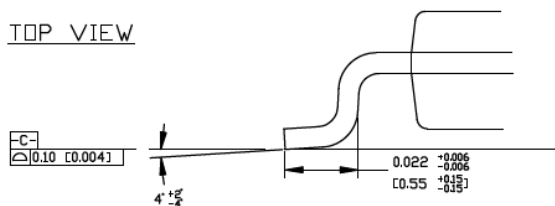

DETAIL A

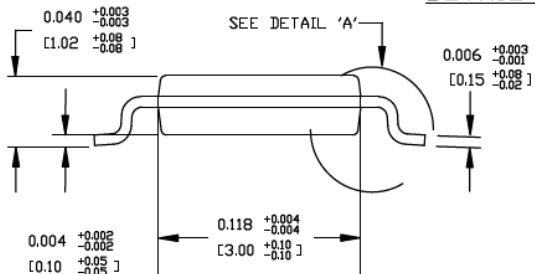

SIDE VIEW

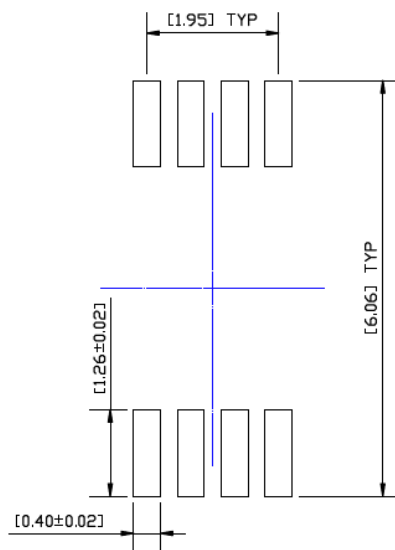

RECOMMENDED LAND PATTERN

#### NOTES:

1. DIMENSIONS ARE IN INCHES [MM].
2. CONTROLLING DIMENSION: MM
3. DIMENSION DOES NOT INCLUDE MOLD FLASH OR PROTRUSIONS, EITHER OF WHICH SHALL NOT EXCEED 0.008 [0.20] PER SIDE.

Note: For the most current package drawings, please see the Microchip Packaging Specification located at <http://www.microchip.com/packaging>.

**Package Outlines and Dimensions**

**TITLE**

8 LEAD MSOP EPAD PACKAGE OUTLINE & RECOMMENDED LAND PATTERN

DRAWING #	MSOPEP-8LD-PL-1	UNIT	MM [INCH]
-----------	-----------------	------	-----------

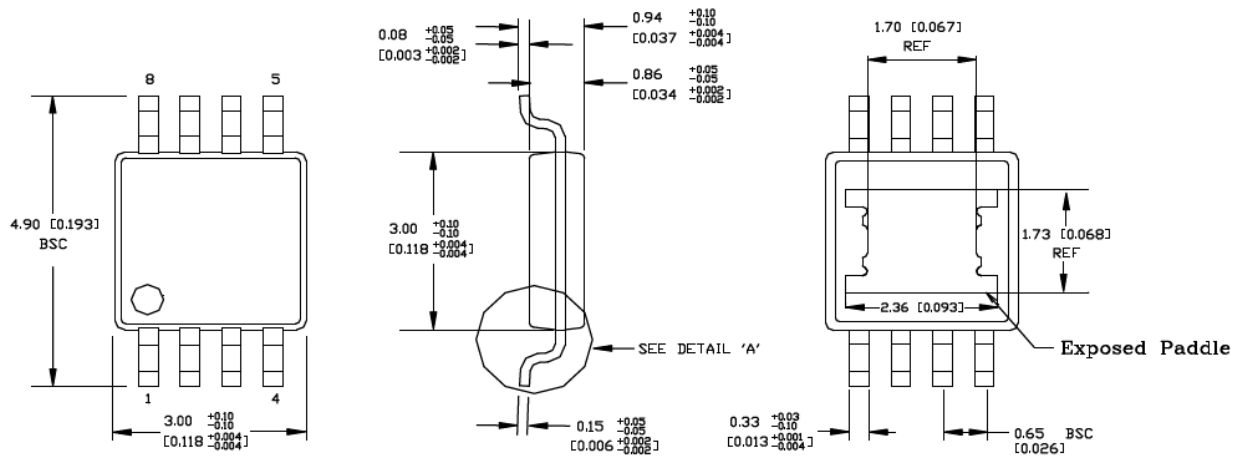

TOP VIEW

END VIEW

BOTTOM VIEW

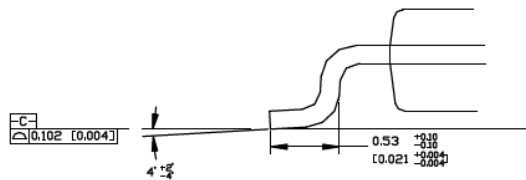

DETAIL A

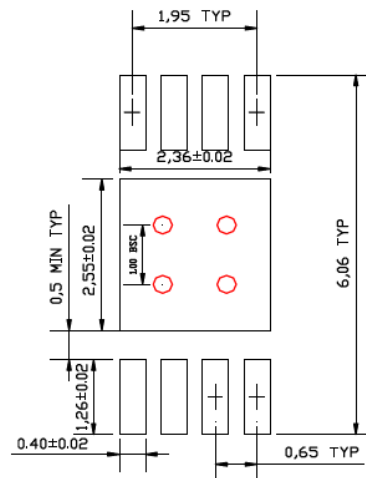

RECOMMENDED LAND PATTERN

**NOTE:**

1. DIMENSION DOES NOT INCLUDE MOLD FLASH OR PROTRUSIONS, EITHER OF WHICH SHALL NOT EXCEED 0.20 [0.008] PER SIDE
2. RED CIRCLES IN LAND PATTERN REPRESENT THERMAL VIAS, RECOMMENDED SIZE IS 0.30-0.35MM IN DIAMETER, 1.00 PITCH AND SHOULD BE CONNECTED TO GND FOR MAXIMUM PERFORMANCE

Note: For the most current package drawings, please see the Microchip Packaging Specification located at <http://www.microchip.com/packaging>.

## Package Outlines and Dimensions

### TITLE

10 LEAD MSOP PACKAGE OUTLINE & RECOMMENDED LAND PATTERN

DRAWING #	MSOP-10LD-PL-1	UNIT	INCH [MM]
-----------	----------------	------	-----------

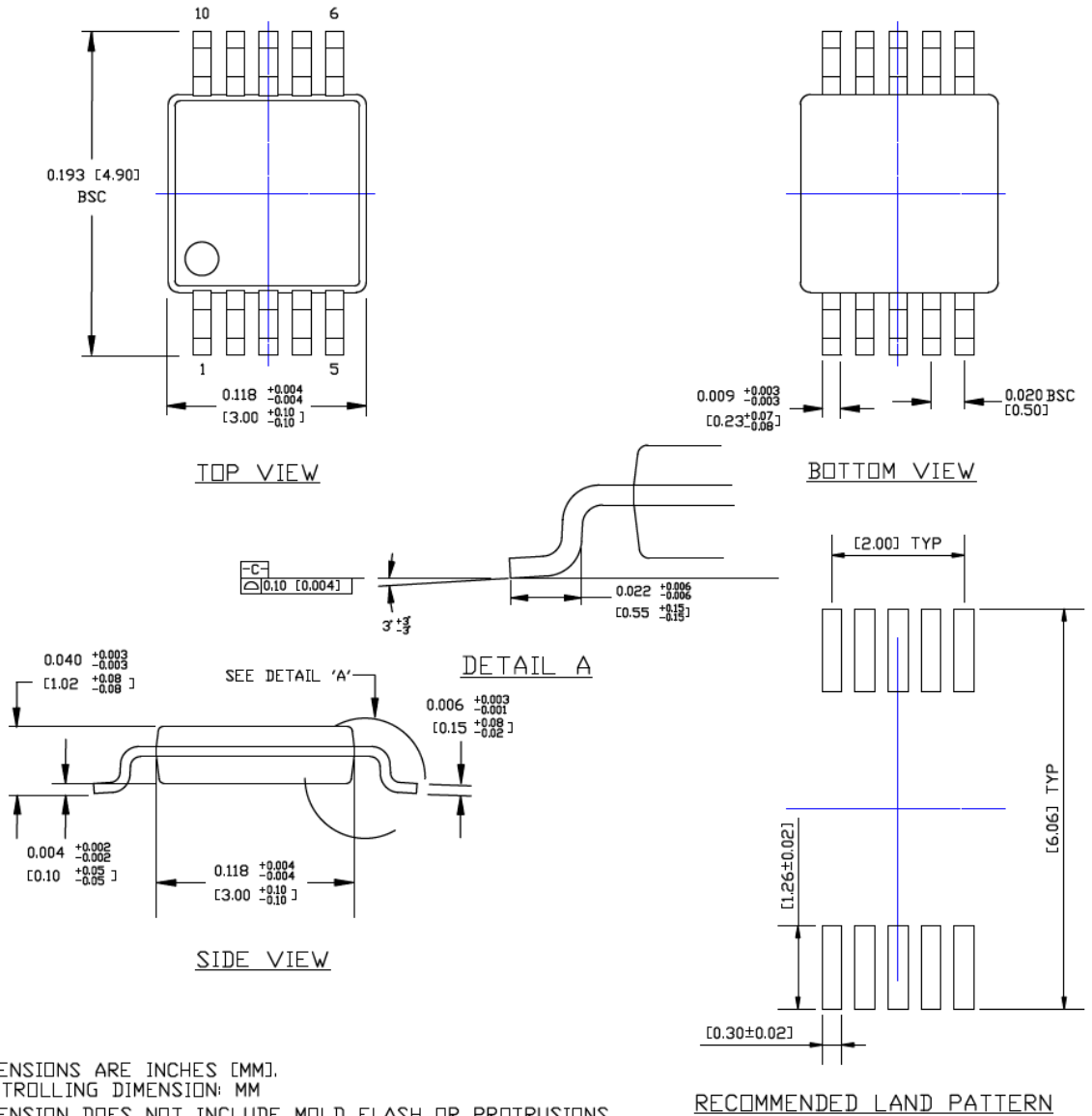

### NOTES:

1. DIMENSIONS ARE INCHES [MM].
2. CONTROLLING DIMENSION: MM
3. DIMENSION DOES NOT INCLUDE MOLD FLASH OR PROTRUSIONS, EITHER OF WHICH SHALL NOT EXCEED 0.008 [0.20] PER SIDE.

Note: For the most current package drawings, please see the Microchip Packaging Specification located at <http://www.microchip.com/packaging>.

**Package Outlines and Dimensions**

**TITLE**

10 LEAD MSOP EPAD PACKAGE OUTLINE & RECOMMENDED LAND PATTERN

<b>DRAWING #</b>	MSOPEP-10LD-PL-1	<b>UNIT</b>	MM [INCH]
------------------	------------------	-------------	-----------

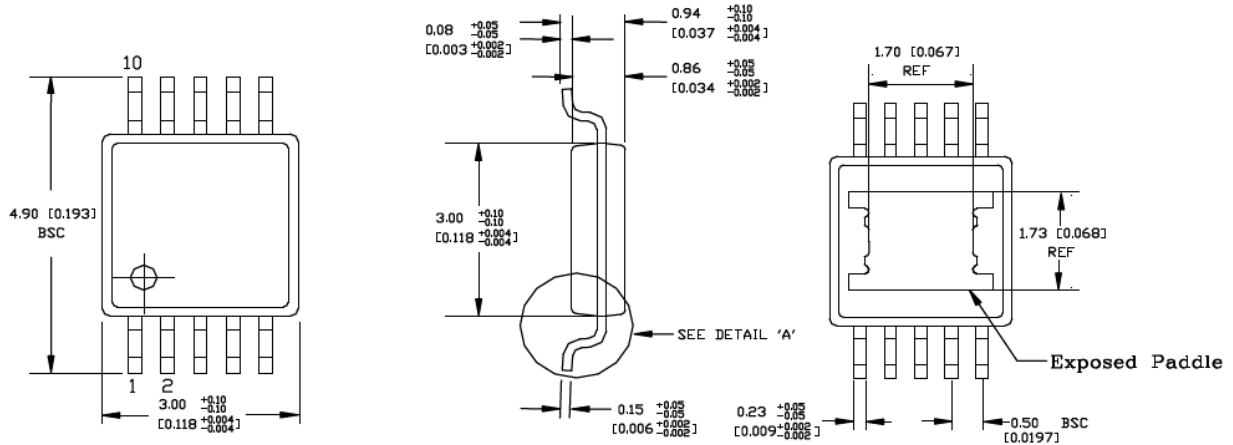

TOP VIEW

END VIEW

BOTTOM VIEW

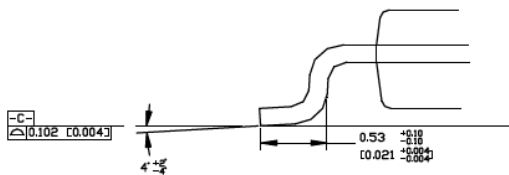

DETAIL A

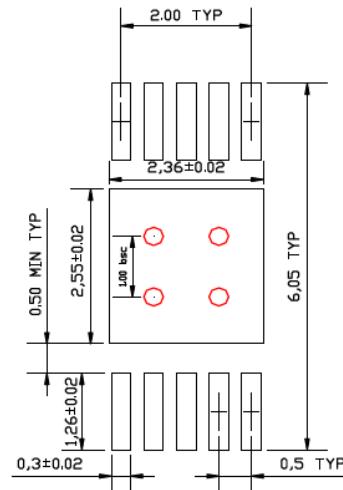

RECOMMENDED LAND PATTERN

**NOTE:**

1. DIMENSION DOES NOT INCLUDE MOLD FLASH OR PROTRUSIONS, EITHER OF WHICH SHALL NOT EXCEED 0.20 [0.008] PER SIDE
2. RED CIRCLES IN LAND PATTERN REPRESENT THERMAL VIAS. RECOMMENDED SIZE IS 0.30-0.35MM IN DIAMETER, 1.00 PITCH AND SHOULD BE CONNECTED TO GND FOR MAXIMUM PERFORMANCE

Note: For the most current package drawings, please see the Microchip Packaging Specification located at <http://www.microchip.com/packaging>.



**MICROCHIP**

---

---

**Package Outlines and Dimensions**

---

---

**NOTES:**



---

---

**Package Outlines and Dimensions**

---

---

**P2QFN**

Micrel Legacy

## Package Outlines and Dimensions

### TITLE

54 LEAD P2QFN 10x6mm PACKAGE (PIP Module) OUTLINE & RECOMMENDED LAND PATTERN

DRAWING #	P2QFN106-54LD-PL-1	UNIT	MM
Lead Frame	Copper	Lead Finish	Matte Tin

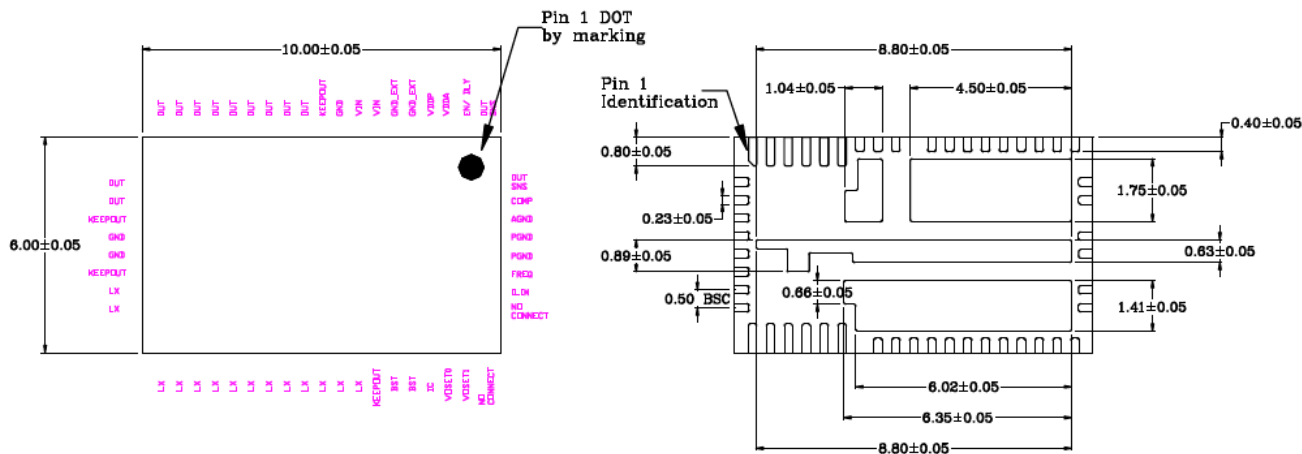

**TOP VIEW**

NOTE : 1, 2, 3

**BOTTOM VIEW**

NOTE : 1, 2, 3

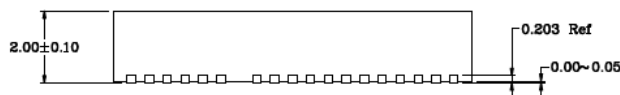

**SIDE VIEW**

NOTE : 1, 2, 3

### NOTE:

1. MAX PACKAGE WARPAGE IS 0.05mm.
2. MAX ALLOWABLE BURR IS 0.076mm IN ALL DIRECTIONS.
3. PIN #1 IS ON TOP WILL BE LASER MARKED.
4. **RED CIRCLES** IN LAND PATTERN REPRESENTS THERMAL VIA. RECOMMENDED SIZE IS 0.30-0.35mm, AT 0.80mm PITCH & SHOULD BE CONNECTED TO GND FOR MAXIMUM PERFORMANCE.
5. **GREEN RECTANGLES** (SHADED AREA) REPRESENT SOLDER STENCIL OPENING ON EXPOSED PAD AREA.
6. **CYAN COLORED** (SHADED) PAD REPRESENT EXPOSED TRACE KEEP OUT AREA.
7. RECOMMENDED LAND PATTERN TOLERANCE IS 0.020mm UNLESS SPECIFIED.
8. SEE RECOMMENDED LAND PATTERN ON PAGE 2.

Note: For the most current package drawings, please see the Microchip Packaging Specification located at <http://www.microchip.com/packaging>.

---

---

**Package Outlines and Dimensions**

---

---

**PBGA**

Micrel Legacy

## Package Outlines and Dimensions

### TITLE

289 LEAD PBGA 19x19mm PACKAGE OUTLINE & RECOMMENDED LAND PATTERN

<b>DRAWING #</b>	PBGA19x19-289LD-PL-1	<b>UNIT</b>	INCH/ MM
------------------	----------------------	-------------	----------

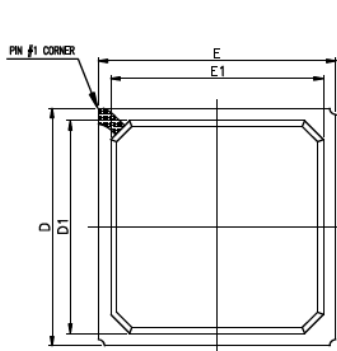

TOP VIEW

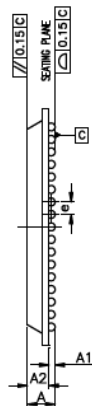

SIDE VIEW

SYMBOL	DIMENSION IN MM			DIMENSION IN INCH		
	MIN.	NOM.	MAX.	MIN.	NOM.	MAX.
A	---	2.21	2.36	---	0.087	0.093
A1	0.43	0.48	0.53	0.017	0.019	0.021
A2	1.63	---	1.83	0.064	---	0.072
b1	0.61	0.63	0.65	0.024	0.025	0.026
b	0.58	0.60	0.62	0.023	0.024	0.025
D	18.95	19.00	19.05	0.747	0.748	0.750
E	18.95	19.00	19.05	0.747	0.748	0.750
D1	16.90	17.00	17.10	0.665	0.668	0.673
D2	16.00 BSC.			0.631 BSC.		
E1	16.90	17.00	17.10	0.665	0.668	0.673
E2	16.00 BSC.			0.631 BSC.		
e	1.00 BSC.			0.039 BSC.		
JEDEC	MO-151					

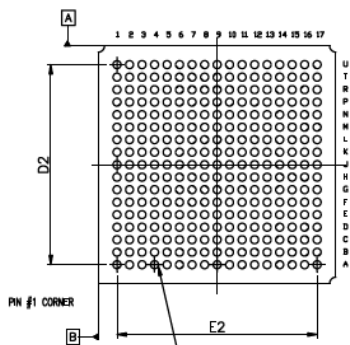

BOTTOM VIEW

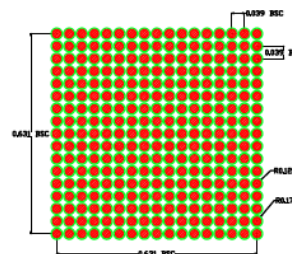

RECOMMENDED LAND PATTERN

NOTES: UNLESS OTHERWISE SPECIFIED

- SPEC "B" IS SOLDER BALL DIAMETER BEFORE REFLOW, B1 IS SOLDER BALL DIAMETER AFTER REFLOW.
- LAND PATTERN UNIT IN INCH, TOLERANCE +/- 0.002
- SHADED RED CIRCLE REPRESENTS CONTACT PAD AREA, GREEN CIRCLES REPRESENTS SOLDER MASK OPENNING.

Note: For the most current package drawings, please see the Microchip Packaging Specification located at <http://www.microchip.com/packaging>.

**Package Outlines and Dimensions**

**TITLE**

400 LEAD PBGA 27x27mm PACKAGE OUTLINE & RECOMMENDED LAND PATTERN

<b>DRAWING #</b>	PBGA27x27-400LD-PL-1	<b>UNIT</b>	MM
------------------	----------------------	-------------	----

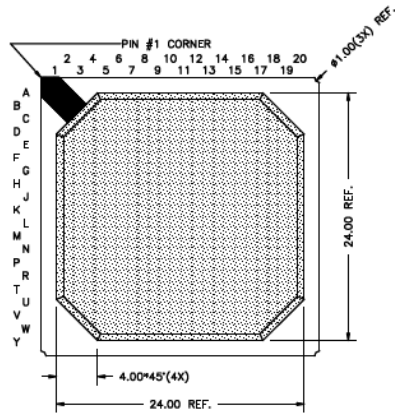

TOP VIEW

Ball Pitch :	127	Substrate Thickness :	0.56
Ball Diameter :	0.75	Mold Thickness :	117

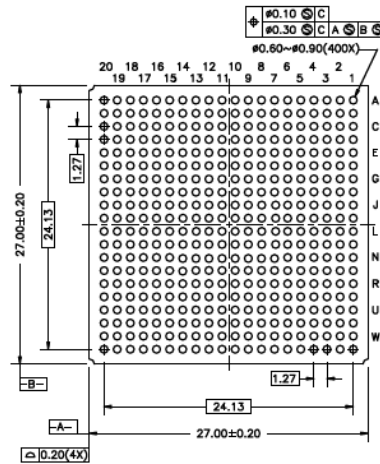

BOTTOM VIEW

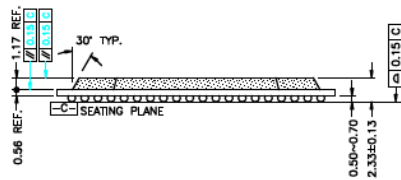

SIDE VIEW

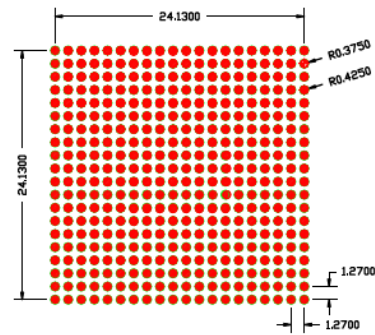

RECOMMENDED LAND PATTERN

**NOTE:**

1. LAND PATTERN UNIT IN MM. TOLERANCE +/- 0.05.

Note: For the most current package drawings, please see the Microchip Packaging Specification located at <http://www.microchip.com/packaging>.



**MICROCHIP**

---

---

**Package Outlines and Dimensions**

---

---

**NOTES:**

---

---

**Package Outlines and Dimensions**

---

---

**PDIP**

Micrel Legacy

**Package Outlines and Dimensions**

**TITLE**

8, 14, 16, 18, 20LD LEAD PDIP PACKAGE OUTLINE & RECOMMENDED LAND PATTERN

<b>DRAWING #</b>	PDIP-300mil-PL-1	<b>UNIT</b>	INCH
<b>Lead Frame</b>	Copper	<b>Lead Finish</b>	Matte Tin

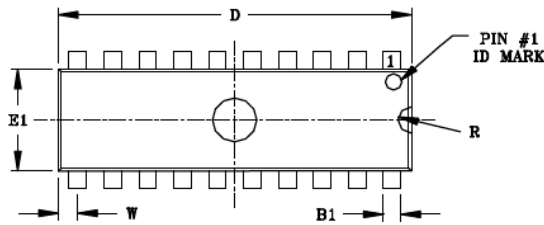

**TOP VIEW**

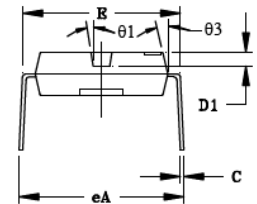
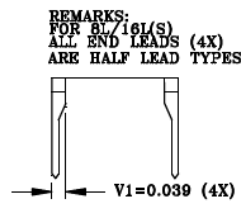

**END VIEW**

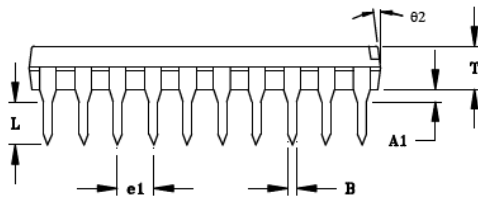

**SIDE VIEW**

**NOTE:**

1. SPADE WIDTH, LEAD WIDTH AND LEAD THICKNESS EXCLUSIVE OF TIN PLATING OR SOLDER PLATING/ DIPPING THICKNESS.
2. PACKAGE OUTLINE EXCLUSIVE OF ANY MOLD FLASHES.
3. PACKAGE OUTLINE EXCLUSIVE OF BURR DIMENSION.
4. \* - REFERENCE DIMENSION.
5. PACKAGE AND FINISHING : TOP, BOTTOM & ALL SIDE: MATTE VDI #24~27.

LEAD TYPE		8LD	14/16LD	18LD	20LD
STAND-OFF	A1	0.015 MIN	0.015 MIN	0.015 MIN	0.015 MIN
LEAD WIDTH *	B	0.018	0.018	0.018	0.018
SPADE WIDTH *	B1	0.060	0.060	0.060	0.060
LEAD THICKNESS *	C	0.010	0.010	0.010	0.010
LENGTH TOL ±0.004	D	0.375	0.750	0.890	1.020
IDENT DEPTH	D1	0.030 ~ 0.060	0.030 ~ 0.060	0.030 ~ 0.060	0.030 ~ 0.060
SHOULDER WIDTH OUTER TO OUTER	E	0.300 ~ 0.325	0.300 ~ 0.325	0.300 ~ 0.325	0.300 ~ 0.325
WIDTH TOL ±0.004	E1	0.250	0.250	0.250	0.250
LEAD SPREAD OUTER TO OUTER	eA	0.320 ~ 0.370	0.320 ~ 0.370	0.320 ~ 0.370	0.320 ~ 0.370
LEAD PITCH *	e1	0.100	0.100	0.100	0.100
LEAD LENGTH TOL ±0.004	L	0.125	0.125	0.125	0.125
IDENT RADIUS	R	0.030	0.030	0.030	0.030
TOTAL THICKNESS TOL ±0.004	T	0.130	0.130	0.130	0.130
LEAD TO END PACKAGE	W	0.025 REF	0.075REF14LD 0.025REF16LD	0.045REF	0.060REF
IDENT DRAFT TOL ±3°	theta 1	7°	7°	7°	7°
END ANGLE (4x) TOL ±3°	theta 2	7°	7°	7°	7°
SIDE ANGLE (4x) TOL ±3°	theta 3	7°	7°	7°	7°

Note: For the most current package drawings, please see the Microchip Packaging Specification located at <http://www.microchip.com/packaging>.



## Package Outlines and Dimensions

**TITLE**

8, 14, 16, 18, 20, 24LD LEAD PDIP PACKAGE OUTLINE &amp; RECOMMENDED LAND PATTERN

<b>DRAWING #</b>	PDIP-300mil-PL-1	<b>UNIT</b>	INCH
<b>Lead Frame</b>	Copper	<b>Lead Finish</b>	Matte Tin

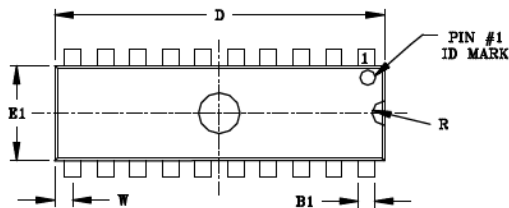
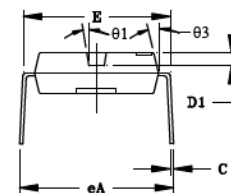
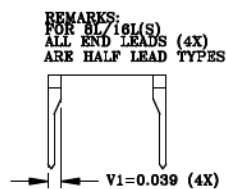
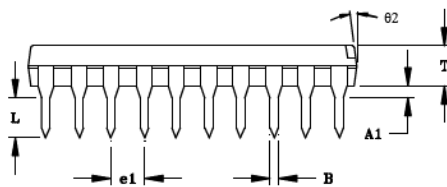
**TOP VIEW**

**END VIEW**

**SIDE VIEW**

LEAD TYPE		8LD	14/16LD	18LD	20LD	24LD
STAND-OFF	A1	0.015 MIN	0.015 MIN	0.015 MIN	0.015 MIN	0.015 MIN
LEAD WIDTH *	B	0.018	0.018	0.018	0.018	0.018
SPADE WIDTH *	B1	0.060	0.060	0.060	0.060	0.060
LEAD THICKNESS *	C	0.010	0.010	0.010	0.010	0.012
LENGTH TOL ±0.004	D	0.375	0.750	0.890	1.020	1.250
IDENT DEPTH	D1	0.030 ~ 0.060	0.030 ~ 0.060	0.030 ~ 0.060	0.030 ~ 0.060	0.030 ~ 0.060
SHOULDER WIDTH OUTER TO OUTER	E	0.300 ~ 0.325	0.300 ~ 0.325	0.300 ~ 0.325	0.300 ~ 0.325	0.300 ~ 0.325
WIDTH TOL ±0.004	E1	0.250	0.250	0.250	0.250	0.250
LEAD SPREAD OUTER TO OUTER	eA	0.320 ~ 0.370	0.320 ~ 0.370	0.320 ~ 0.370	0.320 ~ 0.370	0.320 ~ 0.370
LEAD PITCH *	e1	0.100	0.100	0.100	0.100	0.100
LEAD LENGTH TOL ±0.004	L	0.125	0.125	0.125	0.125	0.125
IDENT RADIUS	R	0.030	0.030	0.030	0.030	0.030
TOTAL THICKNESS TOL ±0.004	T	0.130	0.130	0.130	0.130	0.130
LEAD TO END PACKAGE	W	0.025 REF	0.075REF14LD 0.025REF16LD	0.045REF	0.060REF	0.075REF
IDENT DRAFT TOL ±3°	e1	7°	7°	7°	7°	7°
END ANGLE (4x) TOL ±3°	e2	7°	7°	7°	7°	7°
SIDE ANGLE (4x) TOL ±3°	e3	7°	7°	7°	7°	7°

**NOTE:**

1. SPADE WIDTH, LEAD WIDTH AND LEAD THICKNESS EXCLUSIVE OF TIN PLATING OR SOLDER PLATING/ DIPPING THICKNESS.
2. PACKAGE OUTLINE EXCLUSIVE OF ANY MOLD FLASHES.
3. PACKAGE OUTLINE EXCLUSIVE OF BURR DIMENSION.
4. \* - REFERENCE DIMENSION.
5. PACKAGE AND FINISHING : TOP, BOTTOM & ALL SIDE: MATTE VDI #24~27.

Note: For the most current package drawings, please see the Microchip Packaging Specification located at <http://www.microchip.com/packaging>.

## Package Outlines and Dimensions

### TITLE

8 LEAD PDIP PACKAGE OUTLINE & RECOMMENDED LAND PATTERN

<b>DRAWING #</b>	PDIP-8LD-PL-1	<b>UNIT</b>	INCH
<b>Lead Frame</b>	Copper	<b>Lead Finish</b>	Matte Tin

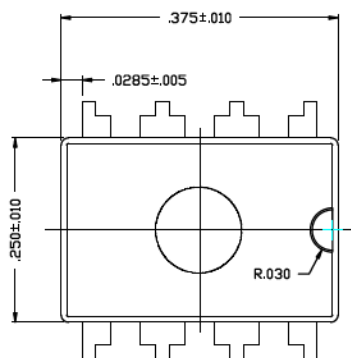

TOP VIEW

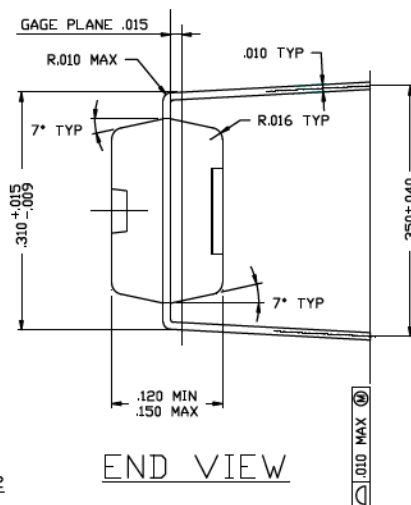

END VIEW

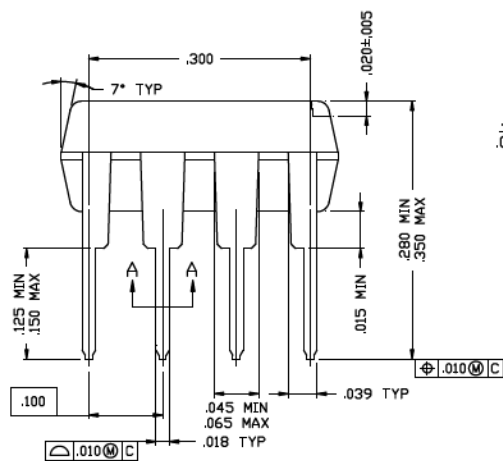

SIDE VIEW

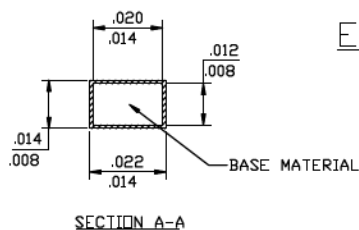

SECTION A-A

Note: For the most current package drawings, please see the Microchip Packaging Specification located at <http://www.microchip.com/packaging>.

**Package Outlines and Dimensions**

**TITLE**

14 LEAD PDIP PACKAGE OUTLINE & RECOMMENDED LAND PATTERN

<b>DRAWING #</b>	PDIP-14LD-PL-1	<b>UNIT</b>	INCH
<b>LEAD FRAME</b>	Copper	<b>LEAD FINISH</b>	Matte Tin

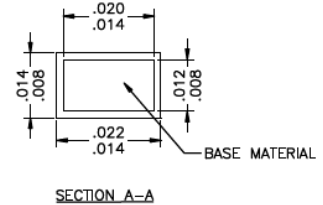
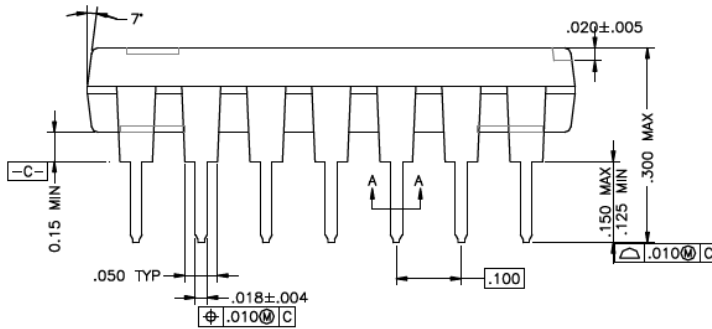
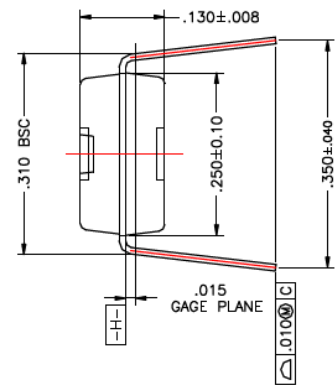
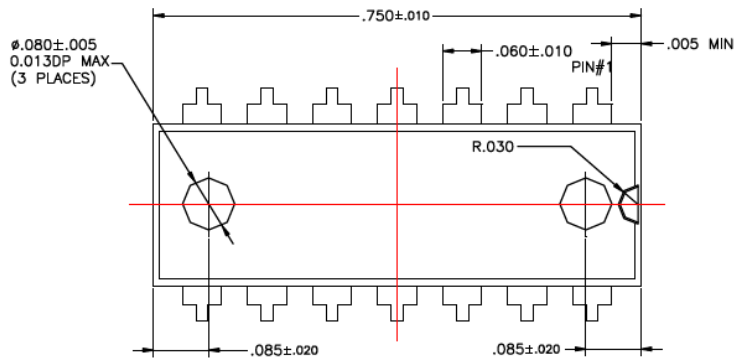

Note: For the most current package drawings, please see the Microchip Packaging Specification located at <http://www.microchip.com/packaging>.

**Package Outlines and Dimensions**

**TITLE**

16 LEAD PDIP PACKAGE OUTLINE & RECOMMENDED LAND PATTERN

<b>DRAWING #</b>	PDIP-16LD-PL-1	<b>UNIT</b>	INCH
<b>LEAD FRAME</b>	Copper	<b>LEAD FINISH</b>	Matte Tin

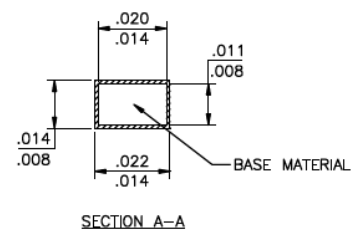
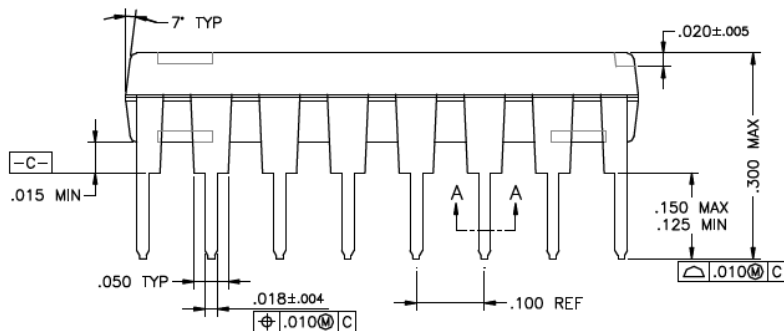
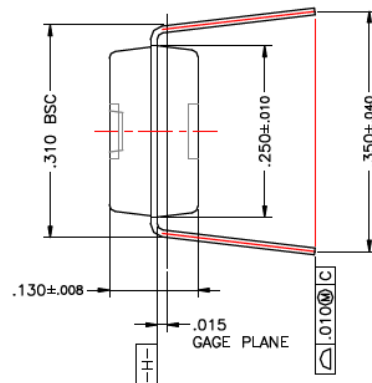
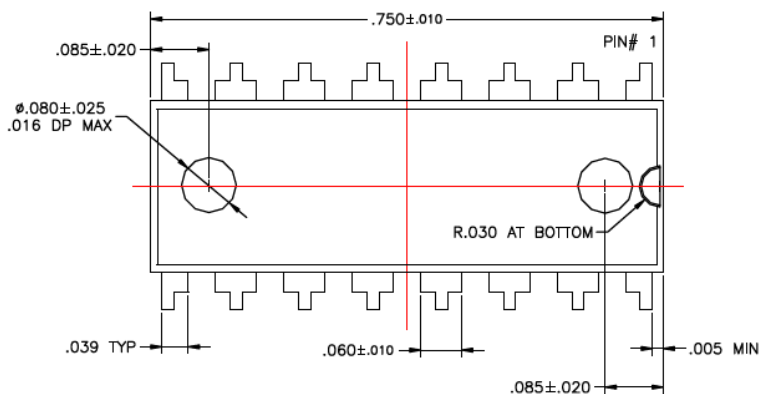

Note: For the most current package drawings, please see the Microchip Packaging Specification located at <http://www.microchip.com/packaging>.

**Package Outlines and Dimensions**

**TITLE**

18 LEAD PDIP PACKAGE OUTLINE & RECOMMENDED LAND PATTERN

<b>DRAWING #</b>	PDIP-18LD-PL-1	<b>UNIT</b>	INCH
<b>LEAD FRAME</b>	Copper	<b>LEAD FINISH</b>	Matte Tin

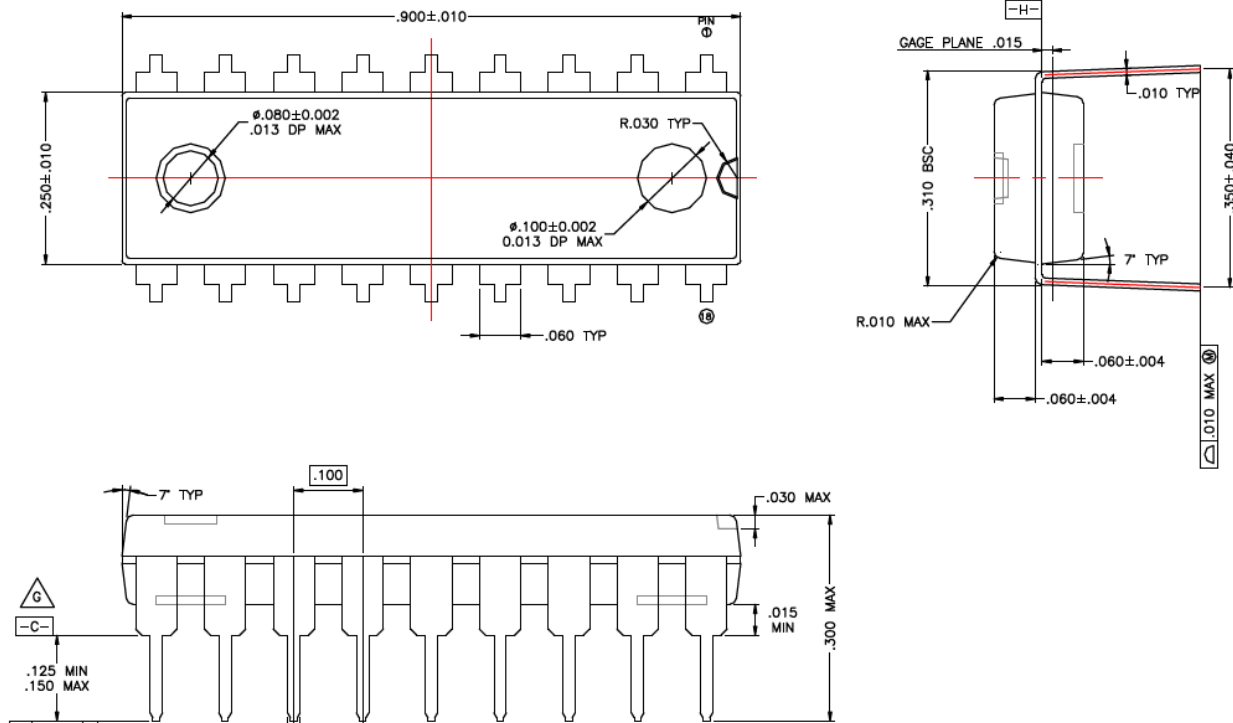

Note: For the most current package drawings, please see the Microchip Packaging Specification located at <http://www.microchip.com/packaging>.

## Package Outlines and Dimensions

**TITLE**

20 LEAD PDIP PACKAGE OUTLINE & RECOMMENDED LAND PATTERN

<b>DRAWING #</b>	PDIP-20LD-PL-1	<b>UNIT</b>	INCH
<b>LEAD FRAME</b>	Copper	<b>LEAD FINISH</b>	Matte Tin

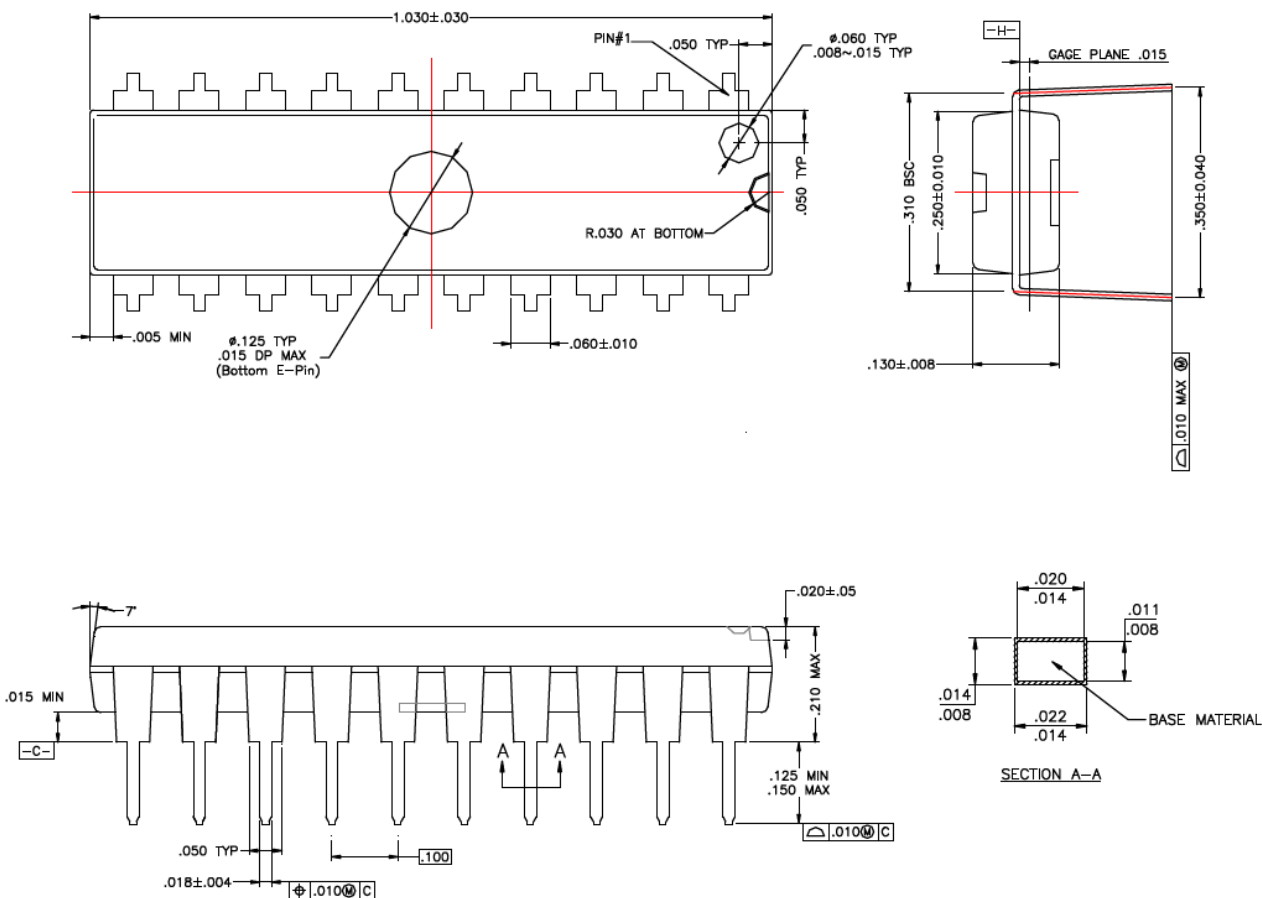

Note: For the most current package drawings, please see the Microchip Packaging Specification located at <http://www.microchip.com/packaging>.

## Package Outlines and Dimensions

**TITLE**

22 LEAD PDIP PACKAGE OUTLINE &amp; RECOMMENDED LAND PATTERN

<b>DRAWING #</b>	PDIP-22LD-PL-1	<b>UNIT</b>	INCH
<b>Lead Frame</b>	Copper	<b>Lead Finish</b>	Matte Tin

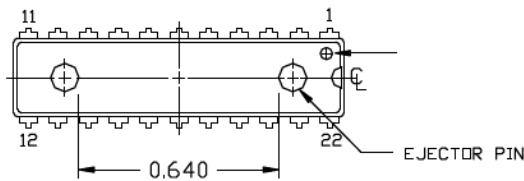

TOP VIEW

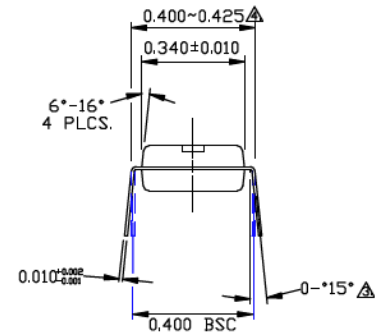

END VIEW

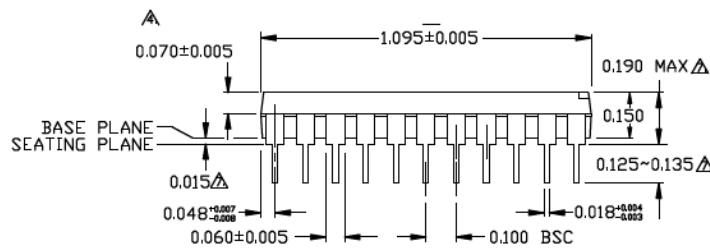

SIDE VIEW

**NOTES:**

- △ REFER TO APPLICABLE SYMBOL LIST.
- △ DIMENSIONING AND TOLERANCING PER ANSI Y14.5-1982.
- △ APPLIES TO SPREAD LEADS PRIOR TO INSTALLATION.
- △ DIMENSIONS ARE TO BE MEASURED AT MAXIMUM MATERIAL CONDITION BUT DO NOT INCLUDE MOLD FLASH. ALLOWABLE MOLD FLASH IS .010 INCH/0.254 MM.
- △ CONTROLLING DIMENSION: INCH.
- △ DIMENSIONS A, A1 & L ARE MEASURED WITH THE PACKAGE SEATED IN JEDEC SEATING PLANE GAUGE GS-3.
- △ THIS PACKAGE CONFORMS TO JEDEC REFERENCE MS-010, VARIATION AA.

Note: For the most current package drawings, please see the Microchip Packaging Specification located at <http://www.microchip.com/packageing>.

**Package Outlines and Dimensions**

**TITLE**

28 LEAD PDIP PACKAGE OUTLINE & RECOMMENDED LAND PATTERN

<b>DRAWING #</b>	PDIP-28LD-PL-1	<b>UNIT</b>	INCH
<b>Lead Frame</b>	Copper	<b>Lead Finish</b>	Matte Tin

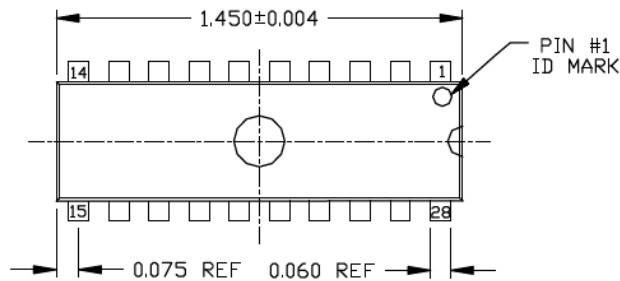

**TOP VIEW**

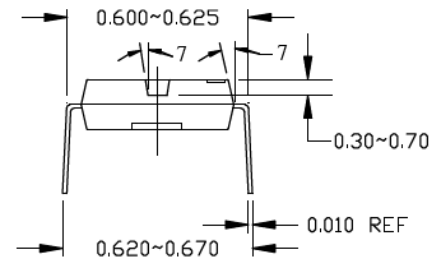

**END VIEW**

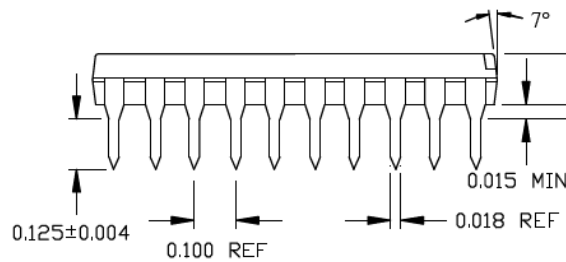

**SIDE VIEW**

1. SPADE WIDTH, LEAD WIDTH AND LEAD THICKNESS EXCLUSIVE OF TIN PLATING OR SOLDER PLATING/ DIPPING THICKNESS.
2. PACKAGE OUTLINE EXCLUSIVE OF ANY MOLD FLASHES.
3. PACKAGE OUTLINE EXCLUSIVE OF BURR DIMENSION.

Note: For the most current package drawings, please see the Microchip Packaging Specification located at <http://www.microchip.com/packaging>.



**Package Outlines and Dimensions**

**TITLE**

40 LEAD PDIP PACKAGE OUTLINE & RECOMMENDED LAND PATTERN

<b>DRAWING #</b>	PDIP-40LD-PL-1	<b>UNIT</b>	INCH
<b>Lead Frame</b>	Copper	<b>Lead Finish</b>	Matte Tin

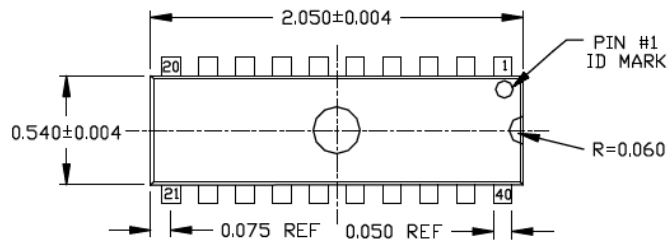

**TOP VIEW**

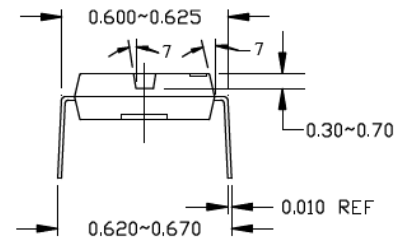

**END VIEW**

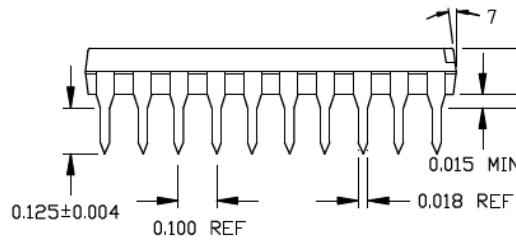

**SIDE VIEW**

1. SPADE WIDTH, LEAD WIDTH AND LEAD THICKNESS EXCLUSIVE OF TIN PLATING OR SOLDER PLATING/ DIPPING THICKNESS.
2. PACKAGE OUTLINE EXCLUSIVE OF ANY MOLD FLASHES.
3. PACKAGE OUTLINE EXCLUSIVE OF BURR DIMENSION.

Note: For the most current package drawings, please see the Microchip Packaging Specification located at <http://www.microchip.com/packaging>.

## Package Outlines and Dimensions

### TITLE

8, 14, 16, 18, 20LD LEAD PDIP PACKAGE OUTLINE & RECOMMENDED LAND PATTERN

<b>DRAWING #</b>	PDIP-300mil-PL-1	<b>UNIT</b>	INCH
<b>Lead Frame</b>	Copper	<b>Lead Finish</b>	Matte Tin

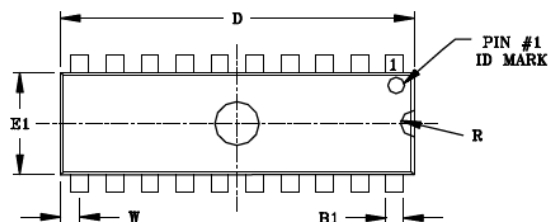

**TOP VIEW**

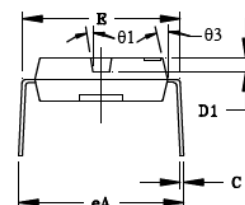
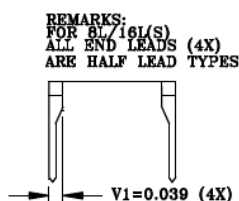

**END VIEW**

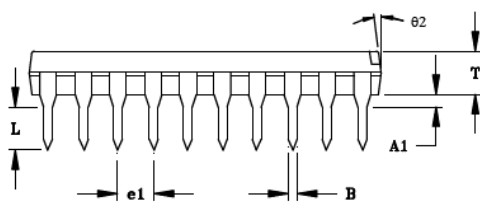

**SIDE VIEW**

#### NOTE:

1. SPADE WIDTH, LEAD WIDTH AND LEAD THICKNESS EXCLUSIVE OF TIN PLATING OR SOLDER PLATING/ DIPPING THICKNESS.
2. PACKAGE OUTLINE EXCLUSIVE OF ANY MOLD FLASHES.
3. PACKAGE OUTLINE EXCLUSIVE OF BURR DIMENSION.
4. \* - REFERENCE DIMENSION.
5. PACKAGE AND FINISHING : TOP, BOTTOM & ALL SIDE: MATTE VDI #24~27.

LEAD TYPE		8LD	14/16LD	18LD	20LD
STAND-OFF	A1	0.015 MIN	0.015 MIN	0.015 MIN	0.015 MIN
LEAD WIDTH *	B	0.018	0.018	0.018	0.018
SPADE WIDTH *	B1	0.060	0.060	0.060	0.060
LEAD THICKNESS *	C	0.010	0.010	0.010	0.010
LENGTH TOL ±0.004	D	0.375	0.750	0.890	1.020
IDENT DEPTH	D1	0.030 ~ 0.060	0.030 ~ 0.060	0.030 ~ 0.060	0.030 ~ 0.060
SHOULDER WIDTH OUTER TO OUTER	E	0.300 ~ 0.325	0.300 ~ 0.325	0.300 ~ 0.325	0.300 ~ 0.325
WIDTH TOL ±0.004	E1	0.250	0.250	0.250	0.250
LEAD SPREAD OUTER TO OUTER	eA	0.320 ~ 0.370	0.320 ~ 0.370	0.320 ~ 0.370	0.320 ~ 0.370
LEAD PITCH *	e1	0.100	0.100	0.100	0.100
LEAD LENGTH TOL ±0.004	L	0.125	0.125	0.125	0.125
IDENT RADIUS	R	0.030	0.030	0.030	0.030
TOTAL THICKNESS TOL ±0.004	T	0.130	0.130	0.130	0.130
LEAD TO END PACKAGE	W	0.025 REF	0.075REF14LD 0.025REF16LD	0.045REF	0.060REF
IDENT DRAFT TOL ±3°	θ1	7°	7°	7°	7°
END ANGLE (4x) TOL ±3°	θ2	7°	7°	7°	7°
SIDE ANGLE (4x) TOL ±3°	θ3	7°	7°	7°	7°

Note: For the most current package drawings, please see the Microchip Packaging Specification located at <http://www.microchip.com/packaging>.

## Package Outlines and Dimensions

**TITLE**

8, 14, 16, 18, 20, 24LD LEAD PDIP PACKAGE OUTLINE &amp; RECOMMENDED LAND PATTERN

<b>DRAWING #</b>	PDIP-300mil-PL-1	<b>UNIT</b>	INCH
<b>Lead Frame</b>	Copper	<b>Lead Finish</b>	Matte Tin

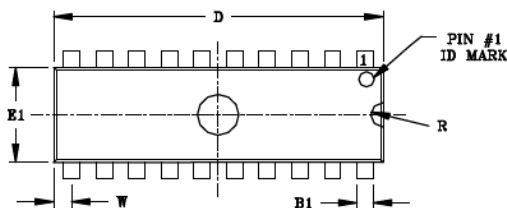
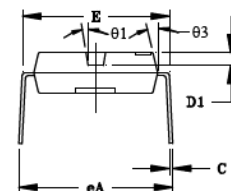
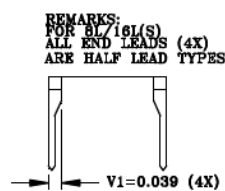
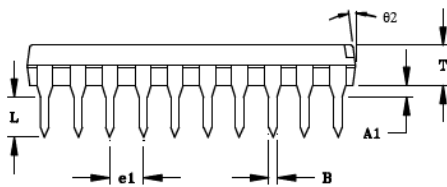
**TOP VIEW**

**END VIEW**

**SIDE VIEW**
**NOTE:**

1. SPADE WIDTH, LEAD WIDTH AND LEAD THICKNESS EXCLUSIVE OF TIN PLATING OR SOLDER PLATING/ DIPPING THICKNESS.
2. PACKAGE OUTLINE EXCLUSIVE OF ANY MOLD FLASHES.
3. PACKAGE OUTLINE EXCLUSIVE OF BURR DIMENSION.
4. \* - REFERENCE DIMENSION.
5. PACKAGE AND FINISHING : TOP, BOTTOM & ALL SIDE: MATTE VDI #24~27.

LEAD TYPE		8LD	14/16LD	18LD	20LD	24LD
STAND-OFF	A1	0.015 MIN	0.015 MIN	0.015 MIN	0.015 MIN	0.015 MIN
LEAD WIDTH *	B	0.018	0.018	0.018	0.018	0.018
SPADE WIDTH *	B1	0.060	0.060	0.060	0.060	0.060
LEAD THICKNESS *	C	0.010	0.010	0.010	0.010	0.012
LENGTH TOL ±0.004	D	0.375	0.750	0.890	1.020	1.250
IDENT DEPTH	D1	0.030 ~ 0.060	0.030 ~ 0.060	0.030 ~ 0.060	0.030 ~ 0.060	0.030 ~ 0.060
SHOULDER WIDTH OUTER TO OUTER	E	0.300 ~ 0.325	0.300 ~ 0.325	0.300 ~ 0.325	0.300 ~ 0.325	0.300 ~ 0.325
WIDTH TOL ±0.004	E1	0.250	0.250	0.250	0.250	0.250
LEAD SPREAD OUTER TO OUTER	eA	0.320 ~ 0.370	0.320 ~ 0.370	0.320 ~ 0.370	0.320 ~ 0.370	0.320 ~ 0.370
LEAD PITCH *	e1	0.100	0.100	0.100	0.100	0.100
LEAD LENGTH TOL ±0.004	L	0.125	0.125	0.125	0.125	0.125
IDENT RADIUS	R	0.030	0.030	0.030	0.030	0.030
TOTAL THICKNESS TOL ±0.004	T	0.130	0.130	0.130	0.130	0.130
LEAD TO END PACKAGE	W	0.025 REF	0.075REF14LD 0.025REF16LD	0.045REF	0.060REF	0.075REF
IDENT DRAFT TOL ±3°	theta 1	7°	7°	7°	7°	7°
END ANGLE (4x) TOL ±3°	theta 2	7°	7°	7°	7°	7°
SIDE ANGLE (4x) TOL ±3°	theta 3	7°	7°	7°	7°	7°

Note: For the most current package drawings, please see the Microchip Packaging Specification located at <http://www.microchip.com/packaging>.



**MICROCHIP**

---

---

**Package Outlines and Dimensions**

---

---

**NOTES:**

---

---

**Package Outlines and Dimensions**

---

---

**PKQFN**

Micrel Legacy

## Package Outlines and Dimensions

### TITLE

54 LEAD PKQFN 10x6mm PACKAGE (Module) OUTLINE & RECOMMENDED LAND PATTERN

<b>DRAWING #</b>	PKQFN106-54LD-PL-1	<b>UNIT</b>	MM
<b>Lead Frame</b>	Copper	<b>Lead Finish</b>	Matte Tin

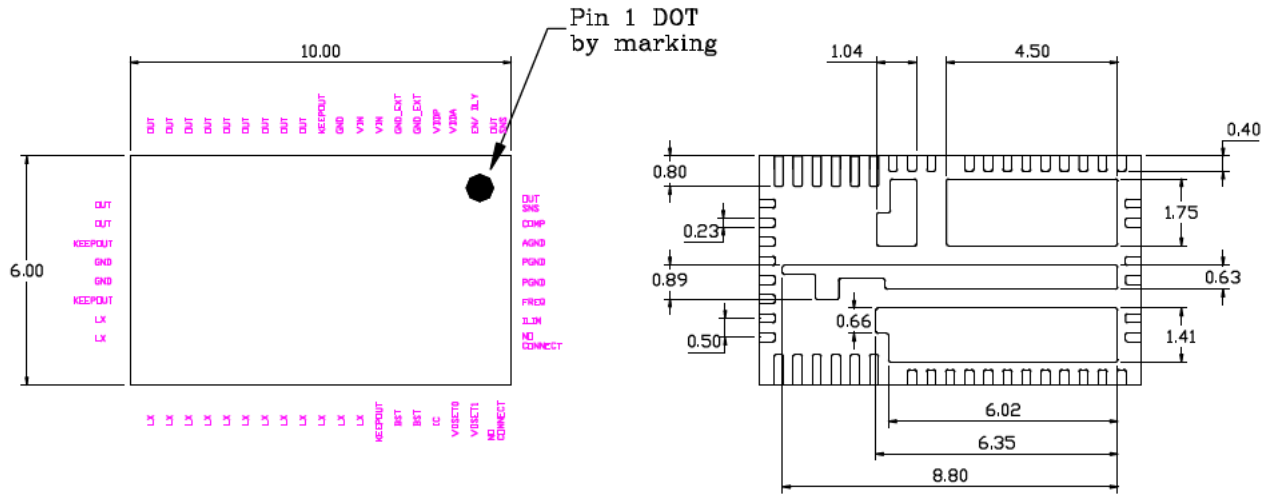

**TOP VIEW**

NOTE 1, 2, 3

**BOTTOM VIEW**

NOTE 1, 2, 3

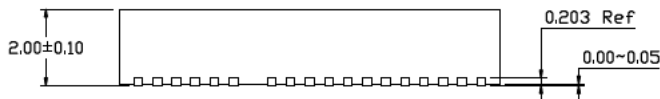

**SIDE VIEW**

NOTE 1, 2, 3

Note: For the most current package drawings, please see the Microchip Packaging Specification located at <http://www.microchip.com/packaging>.

---

---

**Package Outlines and Dimensions**

---

---

**PLCC**

Micrel Legacy

## Package Outlines and Dimensions

### TITLE

20 LEAD PLCC PACKAGE OUTLINE & RECOMMENDED LAND PATTERN

<b>DRAWING #</b>	PLCC-20LD-PL-1	<b>UNIT</b>	INCH
<b>Lead Frame</b>	Copper	<b>Lead Finish</b>	Matte Tin

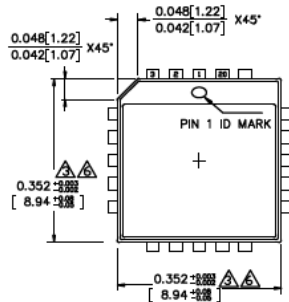

TOP VIEW

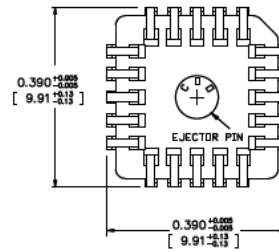

BOTTOM VIEW

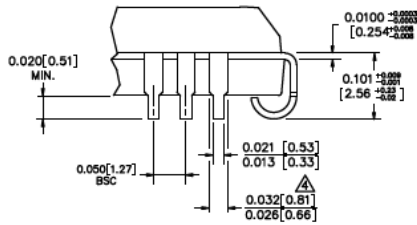

DETAIL "A"

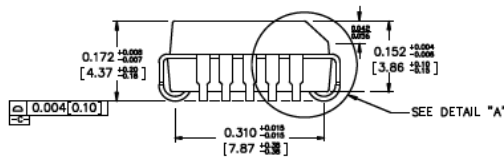

SIDE VIEW

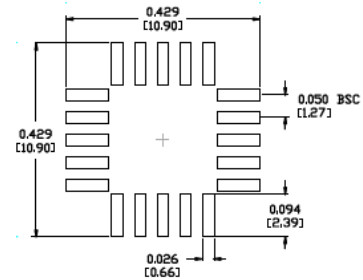

RECOMMENDED LAND PATTERN

- NOTES:
1. DIMENSIONS ARE IN INCHES [MM].
  2. CONTROLLING DIMENSION: INCHES.
  3. DIMENSION DOES NOT INCLUDE MOLD FLASH OR PROTRUSIONS, EITHER OF WHICH SHALL NOT EXCEED 0.008 [0.203].
  4. LEAD DIMENSION DOES NOT INCLUDE DAMBAR PROTRUSION.
  5. MAXIMUM AND MINIMUM SPECIFICATIONS ARE INDICATED AS FOLLOWS: MAX/MIN
  6. PACKAGE TOP DIMENSION MAY BE SLIGHTLY SMALLER THAN BOTTOM DIMENSION.

Note: For the most current package drawings, please see the Microchip Packaging Specification located at <http://www.microchip.com/packaging>.



## Package Outlines and Dimensions

**TITLE**

28 LEAD PLCC PACKAGE OUTLINE & RECOMMENDED LAND PATTERN

<b>DRAWING #</b>	PLCC-28LD-PL-1	<b>UNIT</b>	INCH [MM]
------------------	----------------	-------------	-----------

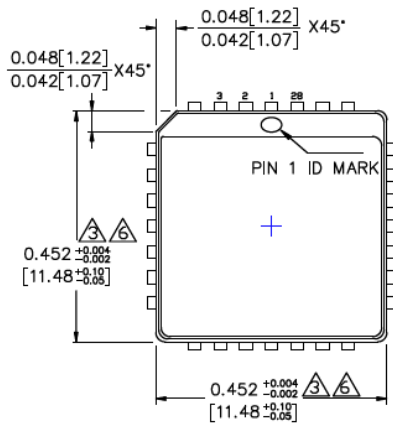

TOP VIEW

DETAIL "A"

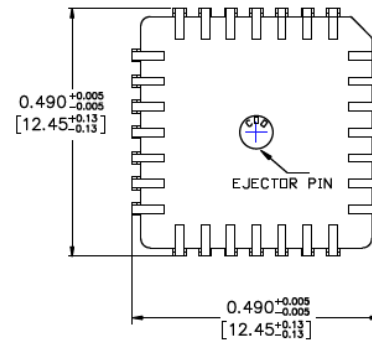

BOTTOM VIEW

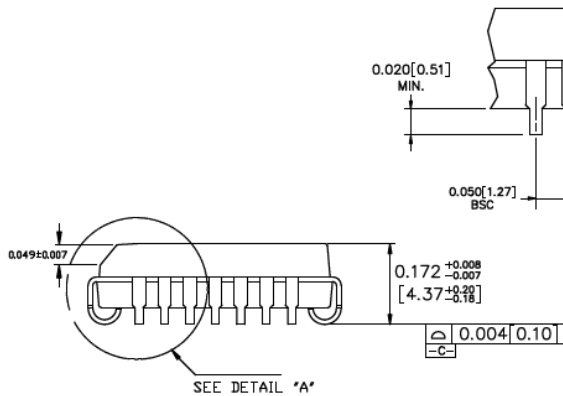

SIDE VIEW

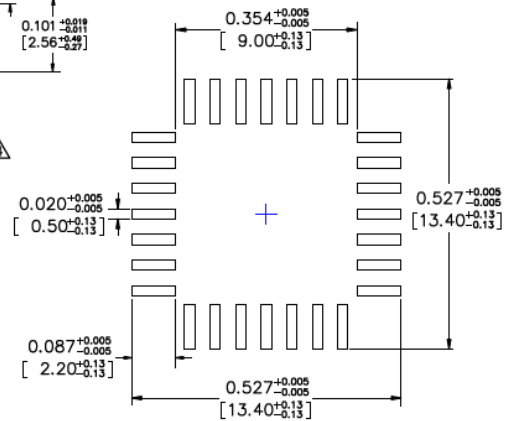

RECOMMENDED LAND PATTERN

**NOTES:**

1. DIMENSIONS ARE IN INCHES [MM].
2. CONTROLLING DIMENSION: INCHES.
3. DIMENSION DOES NOT INCLUDE MOLD FLASH OR PROTRUSIONS, EITHER OF WHICH SHALL NOT EXCEED 0.008 [0.203].
4. LEAD DIMENSION DOES NOT INCLUDE DAMBAR PROTRUSION.
5. MAXIMUM AND MINIMUM SPECIFICATIONS ARE INDICATED AS FOLLOWS : MAX/MIN
6. PACKAGE TOP DIMENSION MAY BE SLIGHTLY SMALLER THAN BOTTOM DIMENSION.

Note: For the most current package drawings, please see the Microchip Packaging Specification located at <http://www.microchip.com/packaging>.

## Package Outlines and Dimensions

### TITLE

44 LEAD PLCC PACKAGE OUTLINE & RECOMMENDED LAND PATTERN

<b>DRAWING #</b>	PLCC-44LD-PL-1	<b>UNIT</b>	INCH
<b>Lead Frame</b>	Copper	<b>Lead Finish</b>	Matte Tin

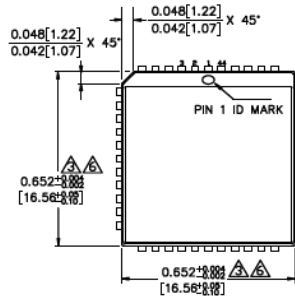

TOP VIEW

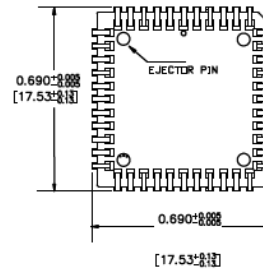

BOTTOM VIEW

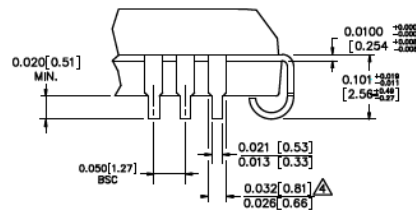

DETAIL "A"

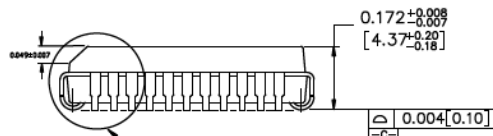

SIDE VIEW

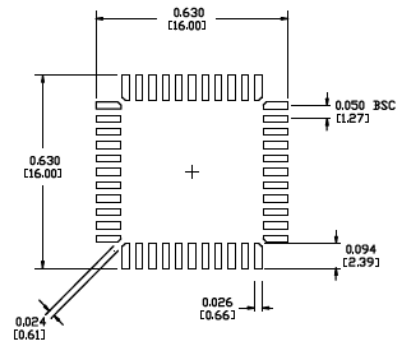

RECOMMENDED LAND PATTERN

- NOTES
1. DIMENSIONS ARE IN INCHES DIM1
  2. CONTROLLING DIMENSION INCHES
  3. DIMENSION DOES NOT INCLUDE MOLD FLASH OR PROTRUSIONS, EITHER OF WHICH SHALL NOT EXCEED 0.008 (0.203)
  4. LEAD DIMENSION DOES NOT INCLUDE DAMBAR PROTRUSION
  5. MAXIMUM AND MINIMUM SPECIFICATIONS ARE INDICATED AS FOLLOWS: MAX/MIN
  6. PACKAGE TOP DIMENSION MAY BE SLIGHTLY SMALLER THAN BOTTOM DIMENSION.
  7. EJECTOR PIN COUNT WILL EITHER BE TWO OR FOUR PINS.

Note: For the most current package drawings, please see the Microchip Packaging Specification located at <http://www.microchip.com/packaging>.

---

---

**Package Outlines and Dimensions**

---

---

**PQFP**

Micrel Legacy

## Package Outlines and Dimensions

### TITLE

128 LEAD PQFP 14x20mm PACKAGE OUTLINE & RECOMMENDED LAND PATTERN

<b>DRAWING #</b>	PQFP14x20-128LD-PL-1	<b>UNIT</b>	MM [INCHES]
------------------	----------------------	-------------	-------------

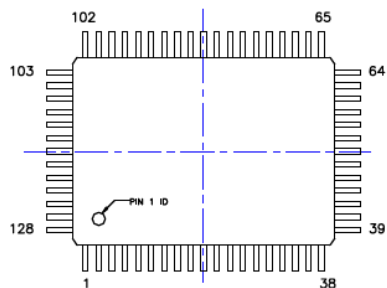

TOP VIEW

Note 1,2,3

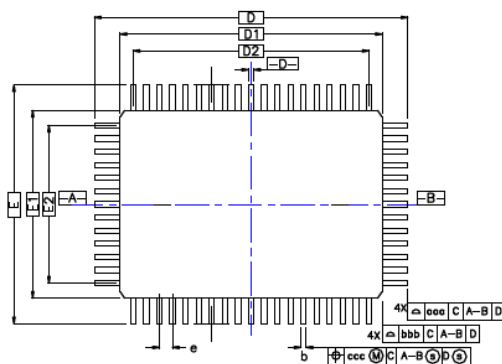

BOTTOM VIEW

Note 1,2,3

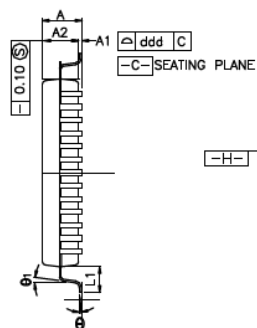

SIDE VIEW

Note 1,2,3

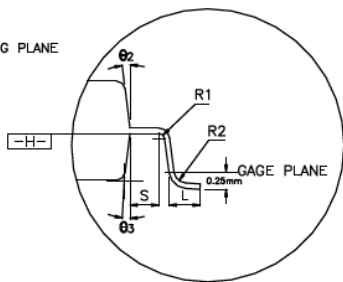

DETAILED VIEW

SYMBOL	MILLIMETER			INCH		
	MIN.	NOM.	MAX.	MIN.	NOM.	MAX.
A	—	—	3.40	—	—	0.134
A1	0.25	—	—	0.010	—	—
A2	2.50	2.72	2.90	0.098	0.107	0.114
D	23.20	BASIC	—	0.913	BASIC	—
D1	20.00	BASIC	—	0.787	BASIC	—
E	17.20	BASIC	—	0.677	BASIC	—
E1	14.00	BASIC	—	0.551	BASIC	—
R2	0.13	—	0.30	0.005	—	0.012
R1	0.13	—	—	0.005	—	—
θ	0°	—	7°	0°	—	7°
θ <sub>1</sub>	0°	—	—	0°	—	—
θ <sub>2</sub> , θ <sub>3</sub>	15°	REF	—	15°	REF	—

SYMBOL	MILLIMETER			INCH		
	MIN.	NOM.	MAX.	MIN.	NOM.	MAX.
c	0.11	0.15	0.23	0.004	0.006	0.009
L	0.73	0.88	1.03	0.029	0.035	0.041
L <sub>1</sub>	1.60	REF	—	0.063	REF	—
S	0.20	—	—	0.008	—	—
b	0.170	0.200	0.270	0.007	0.008	0.011
e	0.50	BSC.	—	0.020	BSC.	—
D2	18.50	—	—	0.728	—	—
E2	12.50	—	—	0.492	—	—
TOLERANCES OF FORM AND POSITION						
aaa	0.20	—	—	0.008	—	—
bbb	0.20	—	—	0.008	—	—
ccc	0.08	—	—	0.003	—	—
ddd	0.08	—	—	0.003	—	—

CONTROL DIMENSIONS ARE IN MILLIMETERS.

### NOTES :

- DIMENSION D1 AND E1 DO NOT INCLUDE MOLD PROTRUSION. ALLOWABLE PROTRUSION IS 0.25mm PER SIDE. DIMENSIONS D1 AND E1 DO INCLUDE MOLD MISMATCH AND ARE DETERMINED AT DATUM PLANE  $\square\text{H}\square$ .
- DIMENSION b DOES NOT INCLUDE DAMBAR PROTRUSION. ALLOWABLE DAMBAR PROTRUSION SHALL BE 0.08mm TOTAL IN EXCESS OF THE b DIMENSION AT MAXIMUM MATERIAL CONDITION. DAMBAR CANNOT BE LOCATED ON THE LOWER RADIUS OR THE LEAD FOOT.
- THE DIAGRAMS DO NOT REPRESENT THE ACTUAL PIN COUNT.
- ALL UNITS IN mm. TOLERANCE  $\pm 0.05$  IF NOT NOTED.

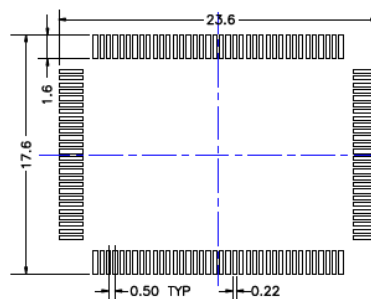

RECOMMENDED LAND PATTERN

Note 4

Note: For the most current package drawings, please see the Microchip Packaging Specification located at <http://www.microchip.com/packaging>.

**Package Outlines and Dimensions**

**TITLE**

208 LEAD PQFP 28x28mm PACKAGE OUTLINE & RECOMMENDED LAND PATTERN

<b>DRAWING #</b>	PQFP28x28-208LD-PL-1	<b>UNIT</b>	INCH
------------------	----------------------	-------------	------

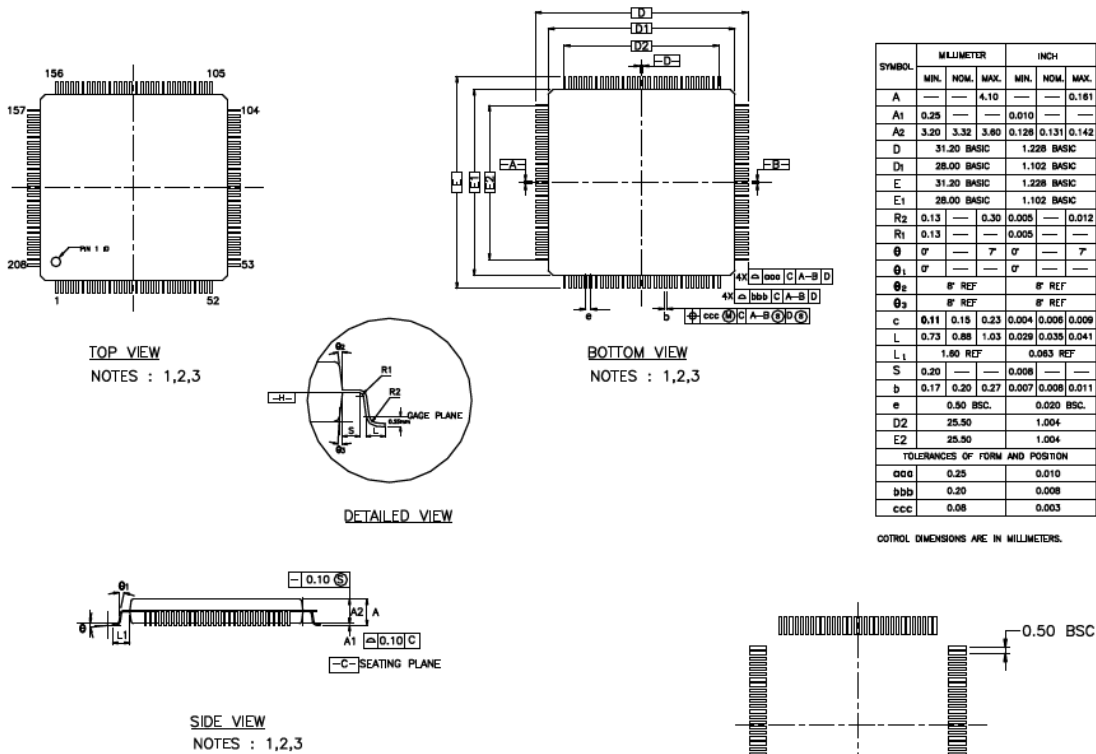

**NOTES :**

1. DIMENSION D1 AND E1 DO NOT INCLUDE MOLD PROTRUSION. ALLOWABLE PROTRUSION IS 0.25mm PER SIDE. DIMENSIONS D1 AND E1 DO INCLUDE MOLD MISMATCH AND ARE DETERMINED AT DATUM PLANE -H- .
2. DIMENSION b DOES NOT INCLUDE DAMBAR PROTRUSION. ALLOWABLE DAMBAR PROTRUSION SHALL BE 0.08 mm TOTAL IN EXCESS OF THE b DIMENSION AT MAXIMUM MATERIAL CONDITION. DAMBAR CANNOT BE LOCATED ON THE LOWER RADIUS OR THE LEAD FOOT.
3. THE DIAGRAMS DO NOT REPRESENT THE ACTUAL PIN COUNT.
4. LAND PATTERN UNIT IN MM. TOLERANCE +/- 0.05.

Note: For the most current package drawings, please see the Microchip Packaging Specification located at <http://www.microchip.com/packaging>.



**MICROCHIP**

---

---

**Package Outlines and Dimensions**

---

---

**NOTES:**

---

---

**Package Outlines and Dimensions**

---

---

**QFN**

Micrel Legacy

## Package Outlines and Dimensions

### TITLE

10 LEAD QFN 2X2mm PACKAGE OUTLINE & RECOMMENDED LAND PATTERN

DRAWING #	QFN22-10LD-PL-1	UNIT	MM
-----------	-----------------	------	----

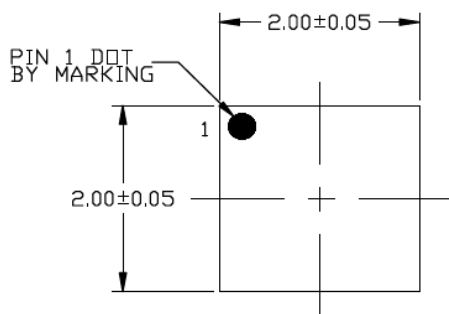

TOP VIEW  
NOTE: 1, 2, 3

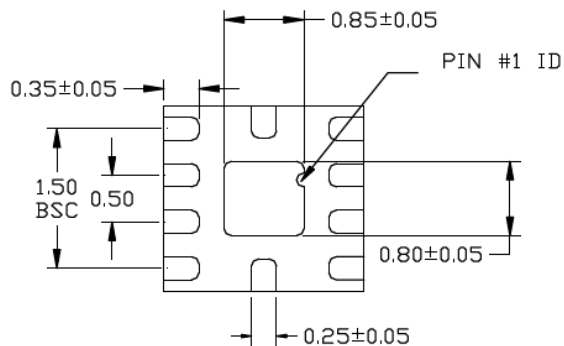

BOTTOM VIEW  
NOTE: 1, 2, 3

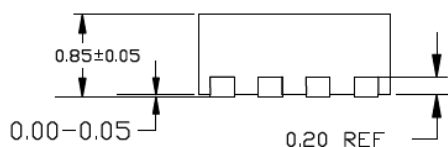

SIDE VIEW  
NOTE: 1, 2, 3

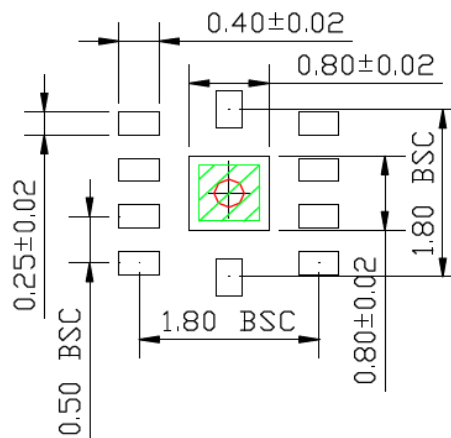

RECOMMENDED LAND PATTERN  
NOTE: 4, 5

### NOTE:

1. MAX PACKAGE WARPAGE IS 0.05 MM
2. MAX ALLOWABLE BURR IS 0.076MM IN ALL DIRECTIONS
3. PIN #1 IS ON TOP WILL BE LASER MARKED
4. RED CIRCLE IN LAND PATTERN INDICATE THERMAL VIA. SIZE SHOULD BE 0.30-0.3MM IN DIAMETER AND SHOULD BE CONNECTED TO GND FOR MAX THERMAL PERFORMANCE
5. GREEN RECTANGLE (SHADED AREA) REPRESENTS OPTIONAL SOLDER STENCIL OPENING ON EXPOSED PAD AREA. RECOMMENDED SIZE IS 0.60x0.60 MM.

Note: For the most current package drawings, please see the Microchip Packaging Specification located at <http://www.microchip.com/packageing>.



---



---

## Package Outlines and Dimensions

---



---

**TITLE**

14 LEAD QFN 2.5x2.5mm PACKAGE OUTLINE &amp; RECOMMENDED LAND PATTERN

DRAWING #	QFN2525-14LD-PL-1	UNIT	MM
-----------	-------------------	------	----

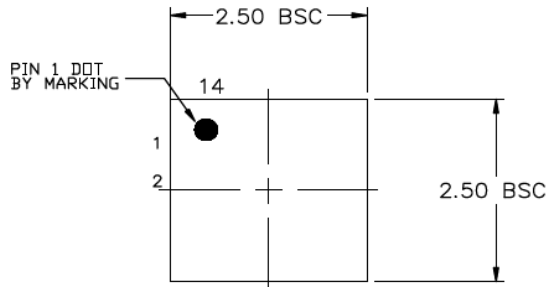

TOP VIEW  
NOTE: 1, 2, 3

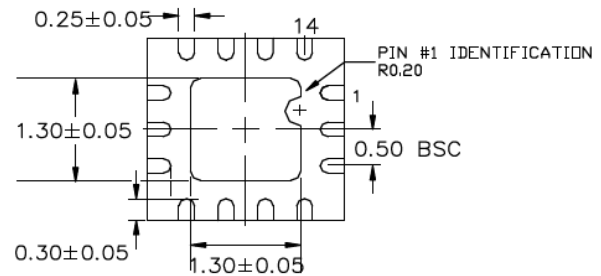

BOTTOM VIEW  
NOTE: 1, 2, 3

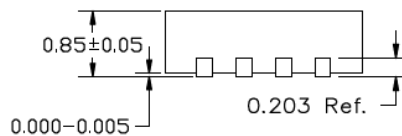

SIDE VIEW  
NOTE: 1, 2, 3

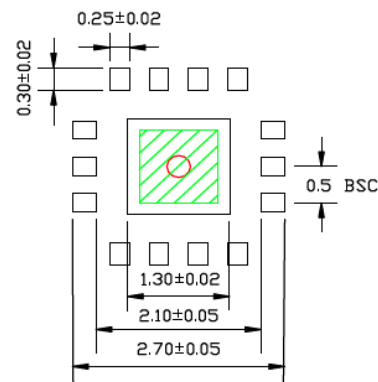

RECOMMENDED LAND PATTERN  
NOTE: 4, 5

**NOTE:**

1. MAX PACKAGE WARPAGE IS 0.05 MM
2. MAX ALLOWABLE BURR IS 0.076MM IN ALL DIRECTIONS
3. PIN #1 IS ON TOP WILL BE LASER MARKED
4. RED CIRCLE IN LAND PATTERN INDICATE THERMAL VIA. SIZE SHOULD BE 0.30-0.3M IN DIAMETER AND SHOULD BE CONNECTED TO GND FOR MAX THERMAL PERFORMANCE
5. GREEN RECTANGLE (SHADED AREA) REPRESENTS SOLDER STENCIL OPENING ON EXPOSED PAD AREA. RECOMMENDED SIZE IS 1.00x1.00 MM

Note: For the most current package drawings, please see the Microchip Packaging Specification located at <http://www.microchip.com/packaging>.

**Package Outlines and Dimensions**

**TITLE**

14 LEAD QFN 2.5x3.2mm PACKAGE OUTLINE & RECOMMENDED LAND PATTERN

<b>DRAWING #</b>	QFN2532-14LD-PL-1	<b>UNIT</b>	MM
------------------	-------------------	-------------	----

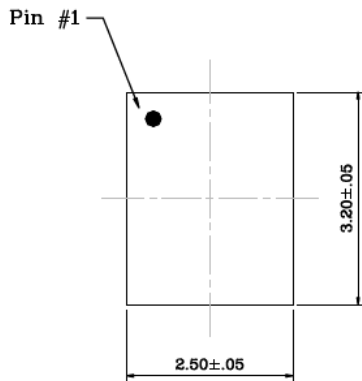

Top View

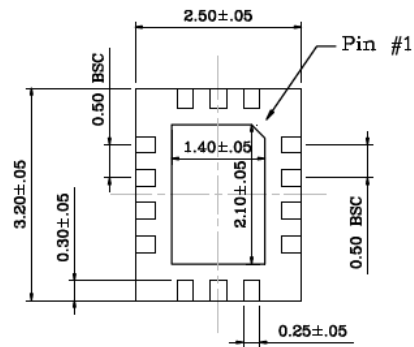

Bottom View



Side View

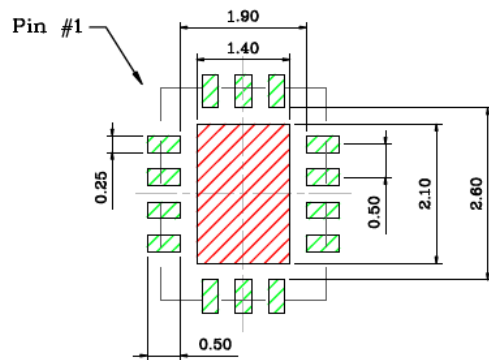

Recommended Land Pattern

**NOTE:**

1. Green shaded rectangles in Recommended Land Pattern are solder stencil opening.
2. Red shaded rectangle in Recommended Land Pattern is keep out area.

Note: For the most current package drawings, please see the Microchip Packaging Specification located at <http://www.microchip.com/packaging>.

## Package Outlines and Dimensions

### THERMALLY ENHANCED PLASTIC VERY THIN AND VERY VERY THIN FINE PITCH QUAD FLAT NO LEAD PACKAGE QFN 16 TERMINALS (3.0X3.0mm) X316/Y316

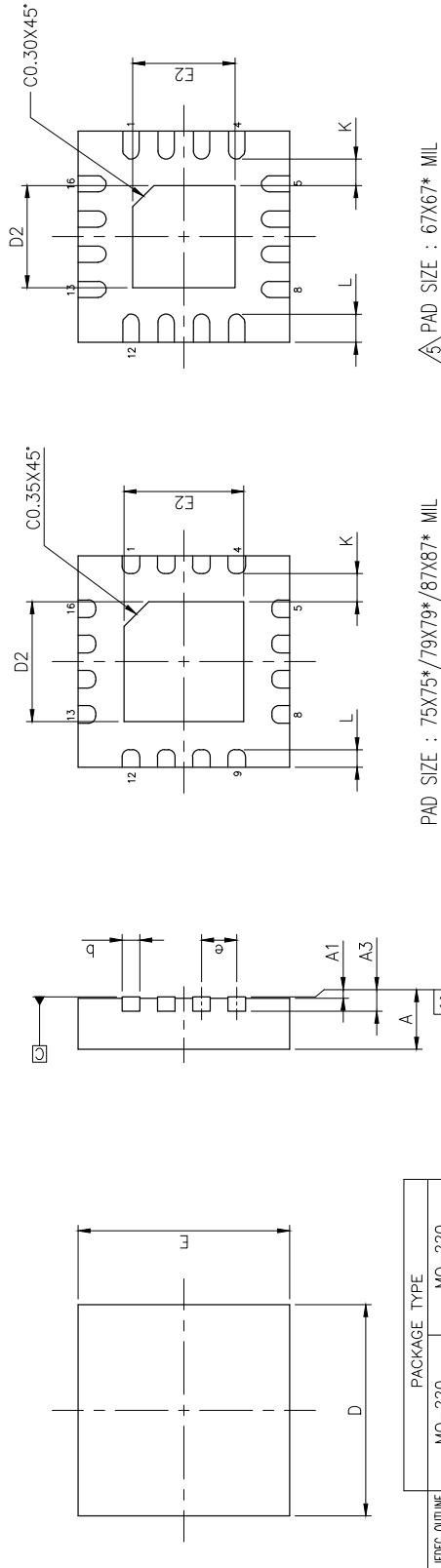

△ PAD SIZE : 67X67\* MIL

△ PAD SIZE : 75X75\*/79X79\*/87X87\* MIL

- NOTES :
1. ALL DIMENSIONS ARE IN MILLIMETERS.
  2. DIMENSION b APPLIES TO METALLIZED TERMINAL AND IS MEASURED BETWEEN 0.15mm AND 0.30mm FROM THE TERMINAL TIP. IF THE TERMINAL HAS THE OPTIONAL RADIUS ON THE OTHER END OF THE TERMINAL, THE DIMENSION b SHOULD NOT BE MEASURED IN THAT RADIUS AREA.
  3. BILATERAL COPLANARITY ZONE APPLIES TO THE EXPOSED HEAT SINK SLUG AS WELL AS THE TERMINALS.

PAD SIZE	D2		E2		L		LEAD FINISH		JEDEC CODE			
	MIN.	MAX.	MIN.	MAX.	MIN.	MAX.	Pure	PPF				
67X67* MIL	1.40	1.45	1.50	1.40	1.45	1.50	0.35	0.40	0.45	V	X	W(V)FEED-6
75X75* MIL	1.65	1.70	1.75	1.65	1.70	1.75	0.35	0.40	0.45	V	X	W(V)FEED-4
79X79* MIL	1.65	1.70	1.75	1.65	1.70	1.75	0.30	0.35	0.40	V	V	W(V)FEED-4
87X87* MIL	1.65	1.70	1.75	1.65	1.70	1.75	0.20	0.25	0.30	V	X	N/A

**Note:** For the most current package drawings, please see the Microchip Packaging Specification located at <http://www.microchip.com/packaging>.

\* \* 表示汎用字元, 此汎用字元可能與其他不同字元所取代, 實際的字元請參照 Bonding diagram 所示。  
 " \* " is an universal character, which means maybe replaced by specific character, the actual character please refers to the bonding diagram.

**Package Outlines and Dimensions**

**TITLE**

16 LEAD QFN 3x3mm PACKAGE OUTLINE & RECOMMENDED LAND PATTERN

DRAWING #	UNIT	MM
QFN33-16LD-PL-1		

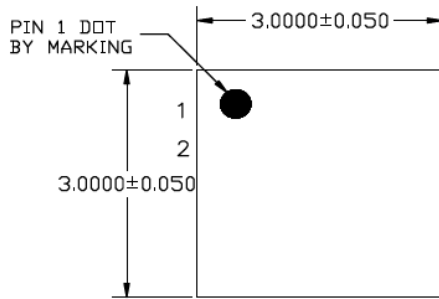

TOP VIEW  
NOTE: 1, 2, 3

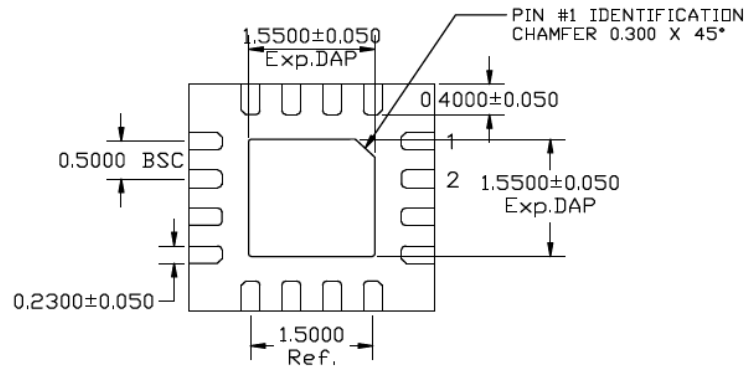

BOTTOM VIEW  
NOTE: 1, 2, 3

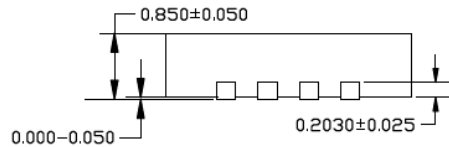

SIDE VIEW  
NOTE: 1, 2, 3

**NOTE:**

1. MAX PACKAGE WARPAGE IS 0.05 MM
2. MAX ALLOWABLE BURR IS 0.076 MM IN ALL DIRECTIONS
3. PIN #1 IS ON TOP WILL BE LASER MARKED
4. RED CIRCLE IN LAND PATTERN INDICATE THERMAL VIA. SIZE SHOULD BE 0.30-0.35 MM IN DIAMETER AND SHOULD BE CONNECTED TO GND FOR MAX THERMAL PERFORMANCE
5. GREEN RECTANGLES (SHADED AREA) INDICATE SOLDER STENCIL OPENING ON EXPOSED PAD AREA. SIZE SHOULD BE 0.60x0.60 MM IN SIZE, 0.20 MM SPACING.

Note: For the most current package drawings, please see the Microchip Packaging Specification located at <http://www.microchip.com/packaging>.

**Package Outlines and Dimensions**

POD-Land Pattern drawing # QFN33-16LD-PL-1

RECOMMENDED LAND PATTERN

NOTE 4, 5

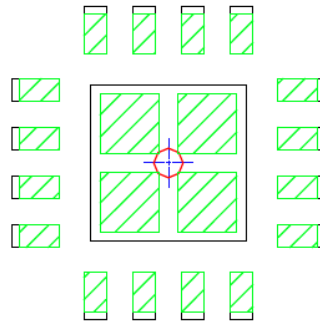

STACKED-UP

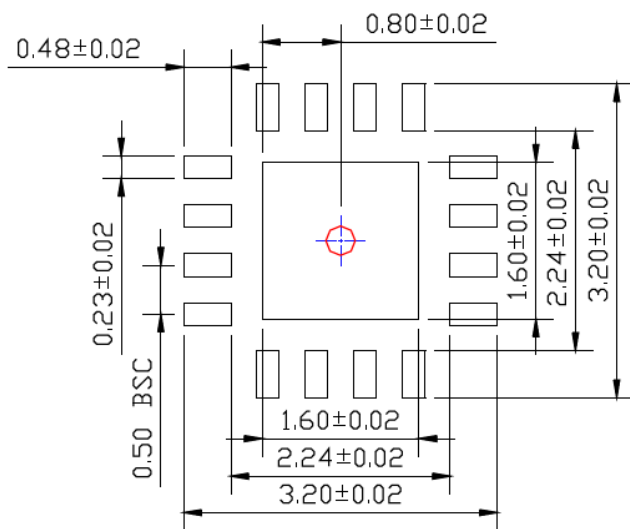

EXPOSED METAL TRACE

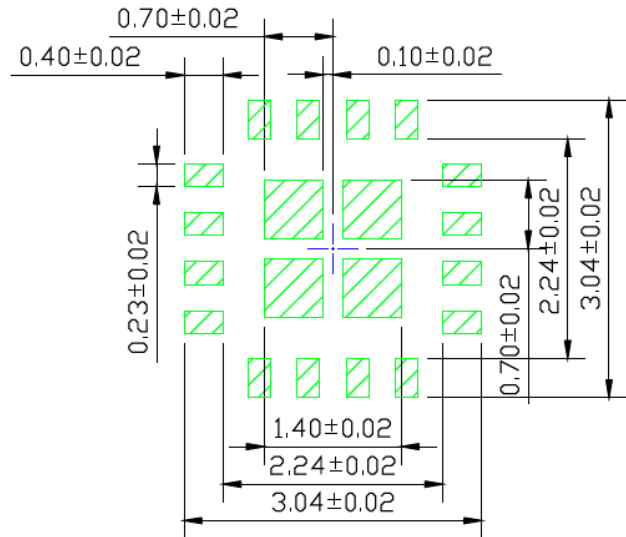

SOLDER STENCIL OPENING

Note: For the most current package drawings, please see the Microchip Packaging Specification located at <http://www.microchip.com/packaging>.

## Package Outlines and Dimensions

### TITLE

16 LEAD QFN 3x3mm PACKAGE OUTLINE & RECOMMENDED LAND PATTERN

DRAWING #	QFN33-16LD-PL-2	UNIT	MM
-----------	-----------------	------	----

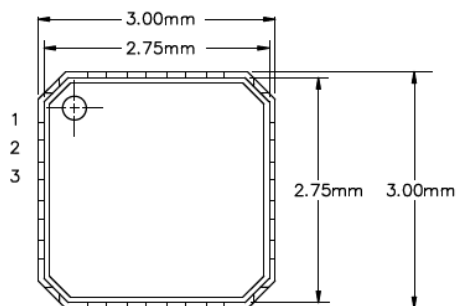

TOP VIEW

NOTE: 1, 2, 3

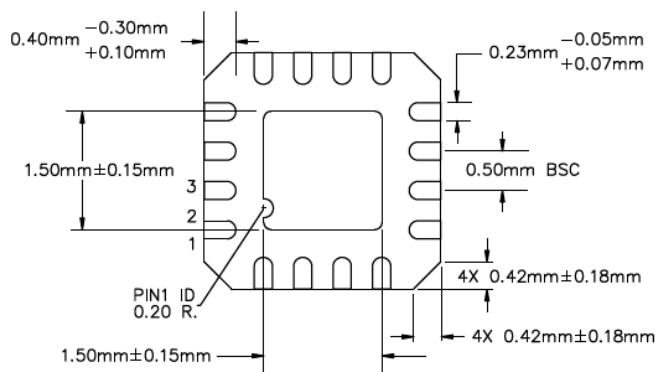

BOTTOM VIEW

NOTE: 1, 2, 3, 4

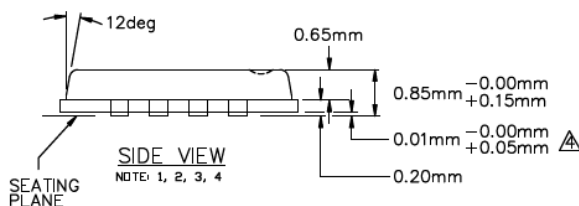

SIDE VIEW

NOTE: 1, 2, 3, 4

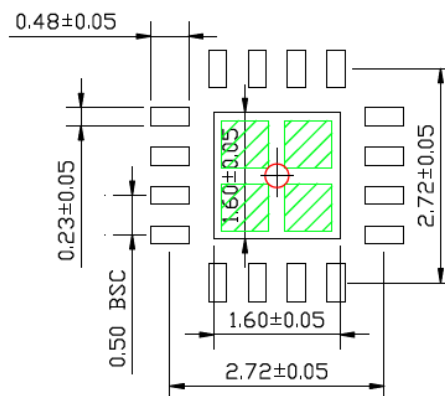

RECOMMENDED LAND PATTERN

NOTE: 5, 6

### NOTE:

1. ALL DIMENSIONS ARE IN MILLIMETERS.
2. THE PIN#1 IDENTIFIER MUST EXIST ON THE TOP SURFACE OF PACKAGE USING IDENTIFICATION MARK OR OTHER FEATURE OF PACKAGE BODY.
3. PACKAGE WARPAGE MAX 0.05mm.
4. APPLIED FOR EXPOSED PAD AND TERMINALS.
5. RED CIRCLE IN LAND PATTERN INDICATE THERMAL VIA. SIZE SHOULD BE 0.30-0.3MM IN DIAMETER AND SHOULD BE CONNECTED TO GND FOR MAX THERMAL PERFORMANCE
6. GREEN RECTANGLES (SHADED AREA) INDICATE SOLDER STENCIL OPENING ON EXPOSED PAD AREA. SIZE SHOULD BE 0.60x0.60 MM IN SIZE, 0.20 MM SPACING.

Note: For the most current package drawings, please see the Microchip Packaging Specification located at <http://www.microchip.com/packaging>.

---



---

## Package Outlines and Dimensions

---



---

**TITLE**

16 LEAD QFN 3x3mm PACKAGE OUTLINE &amp; RECOMMENDED LAND PATTERN

DRAWING #	QFN33-16LD-PL-3	UNIT	MM
Lead Frame	NiPdAu	Lead Finish	NiPdAu

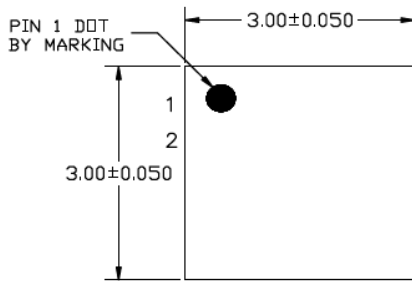

TOP VIEW  
NOTE: 1, 2, 3

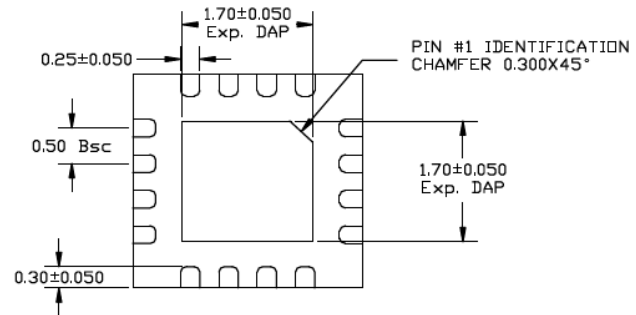

BOTTOM VIEW  
NOTE: 1, 2, 3

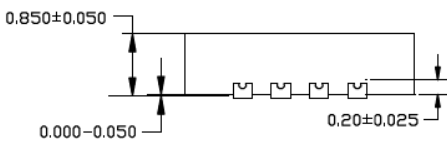

SIDE VIEW  
NOTE: 1, 2, 3

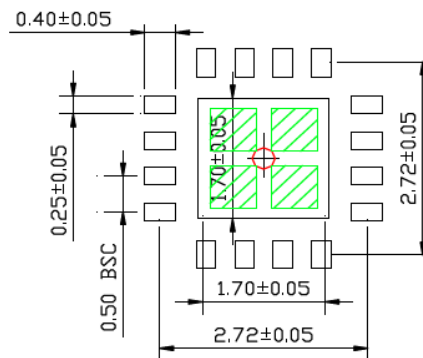

RECOMMENDED LAND PATTERN  
NOTE: 4, 5

**NOTE:**

1. MAX PACKAGE WARPAGE IS 0.05mm.
2. MAX ALLOWABLE BURR IS 0.076mm IN ALL DIRECTIONS
3. PIN #1 IS ON TOP WILL BE LASER MARKED.
4. RED CIRCLE IN LAND PATTERN INDICATES THERMAL VIA. SIZE SHOULD BE 0.30-0.35mm IN DIAMETER AND SHOULD BE CONNECTED TO GND FOR MAX THERMAL PERFORMANCE.
5. GREEN RECTANGLES (SHADED AREA) INDICATE SOLDER STENCIL OPENING ON EXPOSED PAD AREA. SIZE SHOULD BE 0.60x0.60mm IN SIZE, 0.20mm SPACING.

Note: For the most current package drawings, please see the Microchip Packaging Specification located at <http://www.microchip.com/packaging>.

## Package Outlines and Dimensions

### TITLE

16 LEAD QFN 3.0x3.5mm PACKAGE OUTLINE & RECOMMENDED LAND PATTERN

DRAWING #	QFN3035-16LD-PL-1	UNIT	MM
-----------	-------------------	------	----

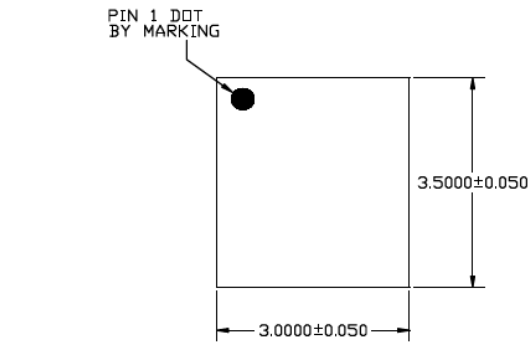

TOP VIEW  
NOTE: 1, 2, 3

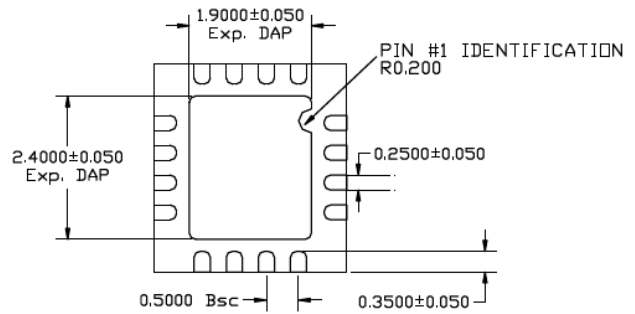

BOTTOM VIEW  
NOTE: 1, 2, 3

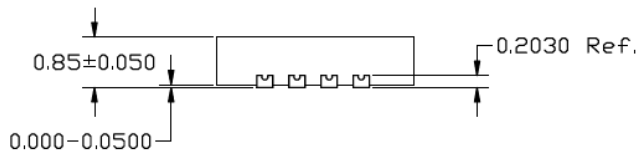

SIDE VIEW  
NOTE: 1, 2, 3

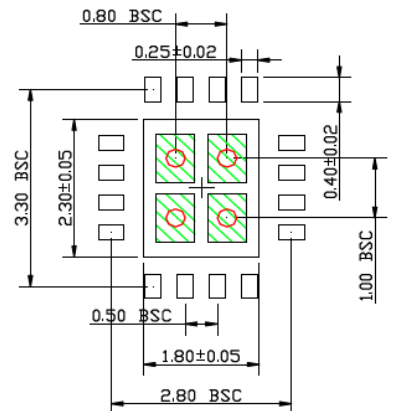

RECOMMENDED LAND PATTERN  
NOTE: 4, 5

#### NOTE:

1. MAX PACKAGE WARPAGE IS 0.05 MM
2. MAX ALLOWABLE BURR IS 0.076MM IN ALL DIRECTIONS
3. PIN #1 IS ON TOP WILL BE LASER MARKED
4. RED CIRCLE IN LAND PATTERN REPRESENT THERMAL VIA. RECOMMENDED DIAMETER IS 0.30 - 0.35 MM AND SHOULD BE CONNECTED TO GND FOR MAX THERMAL PERFORMANCE
5. GREEN RECTANGLES (SHADED AREA) REPRESENT SOLDER STENCIL OPENING ON EXPOSED PAD AREA. SIZE SHOULD BE 0.80x0.60 MM, 0.20 MM SPACING.

Note: For the most current package drawings, please see the Microchip Packaging Specification located at <http://www.microchip.com/packaging>.



**Package Outlines and Dimensions**

**TITLE**

16 LEAD QFN 4.0 x 4.0 mm PACKAGE OUTLINE & RECOMMENDED LAND PATTERN

DRAWING #	QFN44-16LD-PL-1	UNIT	MM
-----------	-----------------	------	----

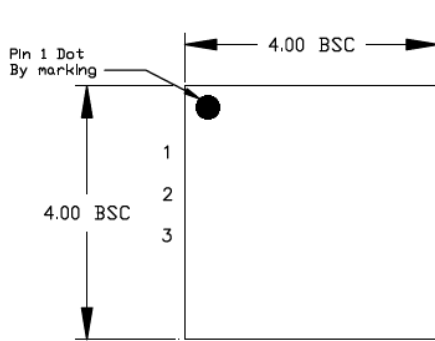

TOP VIEW  
NOTE: 1, 2, 3

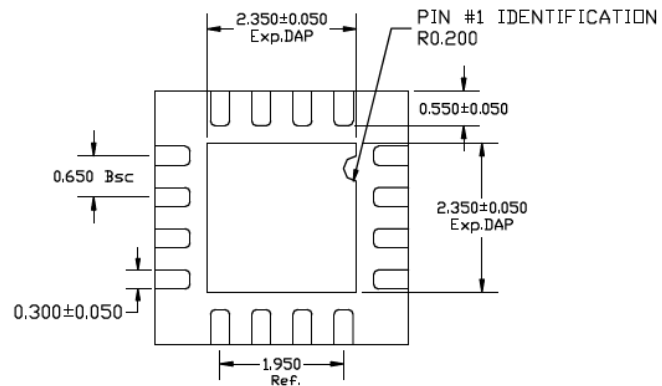

BOTTOM VIEW  
NOTE: 1, 2

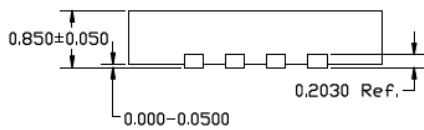

SIDE VIEW  
NOTE: 1, 2

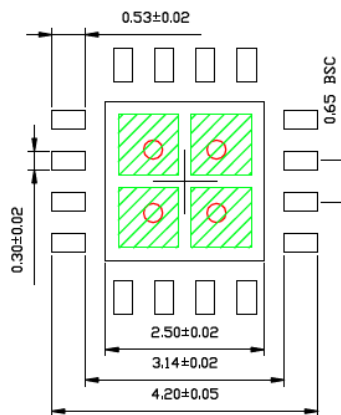

RECOMMENDED LAND PATTERN  
NOTE: 4, 5

**NOTE:**

1. MAX PACKAGE WARPAGE IS 0.05MM
2. MAX ALLOWABLE BURR IS 0.076MM IN ALL DIRECTIONS
3. PIN #1 IS ON TOP WILL BE LASER MARKED
4. GREEN RECTANGLES (SHADED AREA) REPRESENT STENCIL OPENING ON EXPOSED AREA. SIZE IS 0.95X0.95MM, 1.15MM PITCH SPACING
5. RED CIRCLES REPRESENT THERMAL VIAS & SHOULD BE CONNECTED TO GND FOR MAX PERFORMANCE. 0.30 - 0.35 MM RECOMMENDED DIAMETER, 1.0MM PITCH SPACING

Note: For the most current package drawings, please see the Microchip Packaging Specification located at <http://www.microchip.com/packageing>.

## Package Outlines and Dimensions

### TITLE

16 LEAD QFN 4.0 x 4.0 mm PACKAGE OUTLINE & RECOMMENDED LAND PATTERN

<b>DRAWING #</b>	QFN44-16LD-PL-2	<b>UNIT</b>	MM
<b>Lead Frame</b>	NiPdAu	<b>Lead Finish</b>	NiPdAu

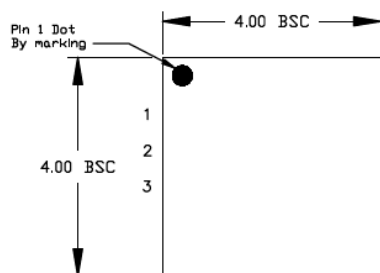

**TOP VIEW**  
NOTE: 1, 2, 3

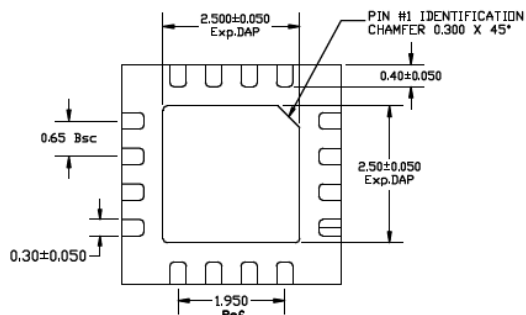

**BOTTOM VIEW**  
NOTE: 1, 2

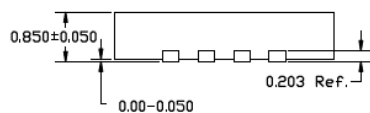

**SIDE VIEW**  
NOTE: 1, 2

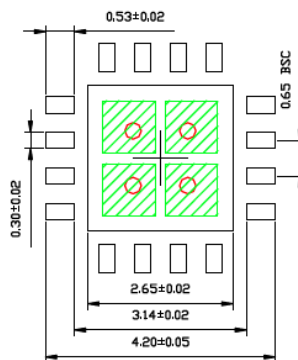

**RECOMMENDED LAND PATTERN**  
NOTE: 4, 5

### NOTE:

1. MAX PACKAGE WARPAGE IS 0.05mm.
2. MAX ALLOWABLE BURR IS 0.076mm IN ALL DIRECTIONS.
3. PIN #1 IS ON TOP WILL BE LASER MARKED.
4. GREEN RECTANGLES (SHADED AREA) REPRESENT STENCIL OPENING ON EXPOSED AREA. SIZE IS 0.95X0.95mm, 1.15MM PITCH SPACING.
5. RED CIRCLES REPRESENT THERMAL VIAS & SHOULD BE CONNECTED TO GND FOR MAX PERFORMANCE. 0.30-0.35mm. RECOMMENDED DIAMETER, 1.0mm PITCH SPACING.

Note: For the most current package drawings, please see the Microchip Packaging Specification located at <http://www.microchip.com/packaging>.

## Package Outlines and Dimensions

**TITLE**

16 LEAD QFN 5x5mm PACKAGE OUTLINE & RECOMMENDED LAND PATTERN

<b>DRAWING #</b>	QFN55-16LD-PL-1	<b>UNIT</b>	MM
------------------	-----------------	-------------	----

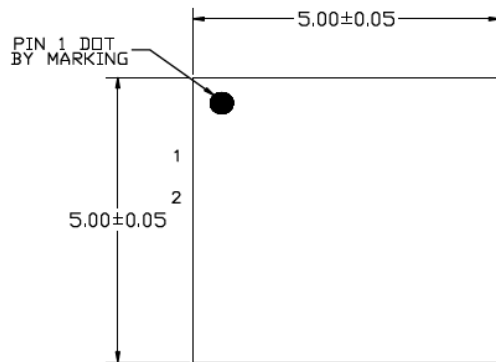

TOP VIEW  
NOTE: 1, 2, 3

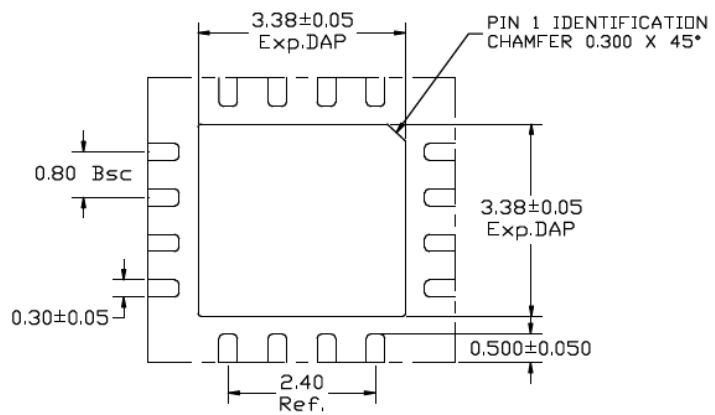

BOTTOM VIEW  
NOTE: 1, 2, 3

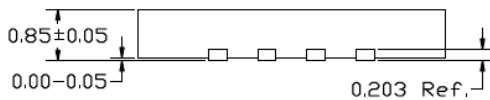

SIDE VIEW  
NOTE: 1, 2, 3

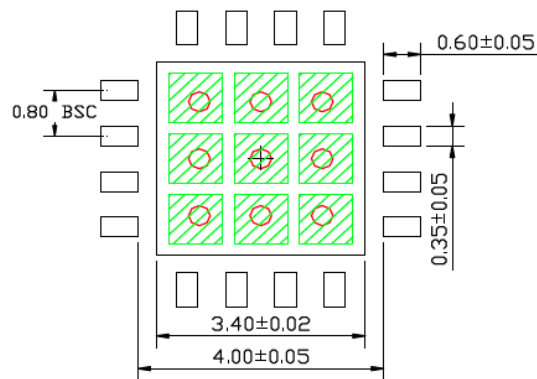

RECOMMENDED LAND PATTERN  
NOTE: 4, 5

**NOTE:**

1. MAX PACKAGE WARPAGE IS 0.05 MM
2. MAX ALLOWABLE BURR IS 0.076MM IN ALL DIRECTIONS
3. PIN #1 IS ON TOP WILL BE LASER MARKED
4. RED CIRCLE IN LAND PATTERN INDICATE THERMAL VIA. SIZE SHOULD BE 0.30-0.3M IN DIAMETER AND SHOULD BE CONNECTED TO GND FOR MAX THERMAL PERFORMANCE
5. GREEN RECTANGLES (SHADED AREA) INDICATE SOLDER STENCIL OPENING ON EXPOSED PAD AREA. SIZE SHOULD BE 0.87x0.87 MM IN SIZE, 1.07 MM PITCH.

Note: For the most current package drawings, please see the Microchip Packaging Specification located at <http://www.microchip.com/packaging>.

## Package Outlines and Dimensions

### TITLE

20 LEAD QFN 3x4mm PACKAGE OUTLINE & RECOMMENDED LAND PATTERN

DRAWING #	QFN34-20LD-PL-1	UNIT	MM
-----------	-----------------	------	----

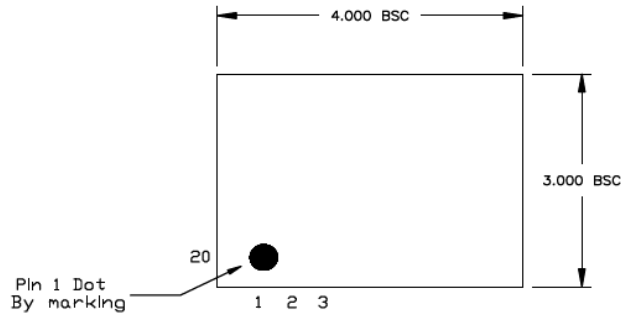

TOP VIEW

NOTE: 1, 2, 3

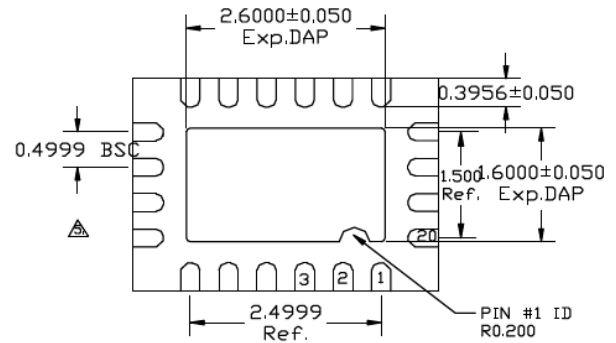

BOTTOM VIEW

NOTE: 1, 2, 3

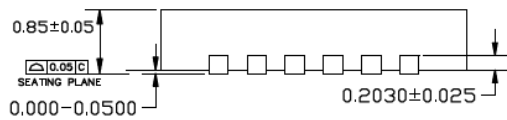

SIDE VIEW

NOTE: 1, 2, 3

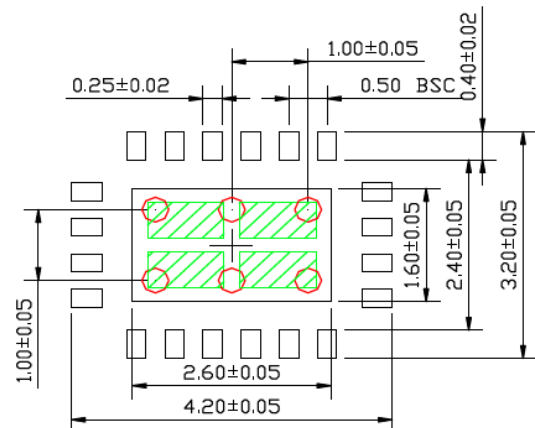

RECOMMENDED LAND PATTERN

NOTE: 4, 5

#### NOTE:

1. MAX PACKAGE WARPAGE IS 0.05 MM
2. MAX ALLOWABLE BURR IS 0.076MM IN ALL DIRECTIONS
3. PIN #1 IS ON TOP WILL BE LASER MARKED
4. RED CIRCLE IN LAND PATTERN INDICATE THERMAL VIA. SIZE SHOULD BE 0.30-0.3MM IN DIAMETER AND SHOULD BE CONNECTED TO GND FOR MAX THERMAL PERFORMANCE
5. GREEN RECTANGLES (SHADED AREA) INDICATE SOLDER STENCIL OPENING ON EXPOSED PAD AREA. SIZE SHOULD BE 1.00x0.50 MM IN SIZE, 0.70 MM PITCH.

Note: For the most current package drawings, please see the Microchip Packaging Specification located at <http://www.microchip.com/packaging>.

---



---

## Package Outlines and Dimensions

---



---

**TITLE**

20 LEAD QFN 3x4mm PACKAGE OUTLINE &amp; RECOMMENDED LAND PATTERN

<b>DRAWING #</b>	QFN34-20LD-PL-2	<b>UNIT</b>	MM
<b>Leadframe</b>	Copper	<b>Lead Finish</b>	Matte Tin

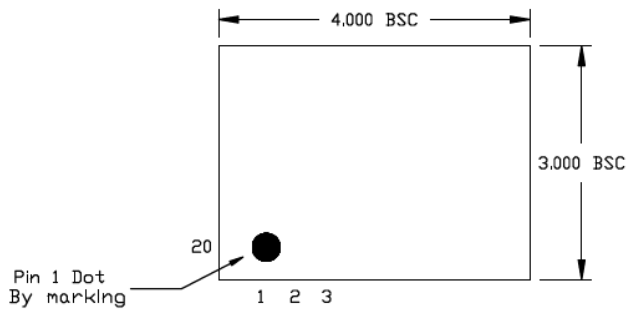
**TOP VIEW**

NOTE: 1, 2, 3

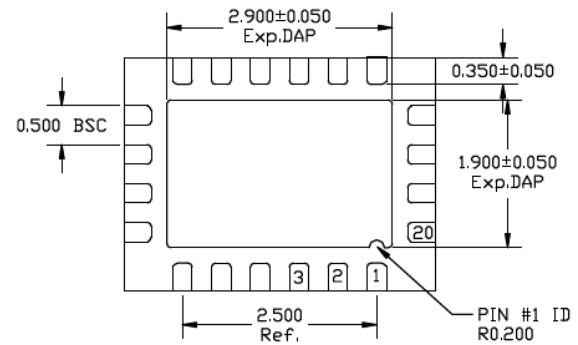
**BOTTOM VIEW**

NOTE: 1, 2, 3

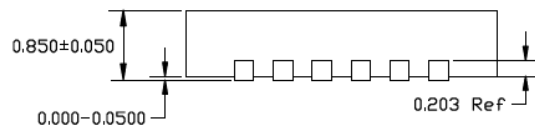
**SIDE VIEW**

NOTE: 1, 2, 3

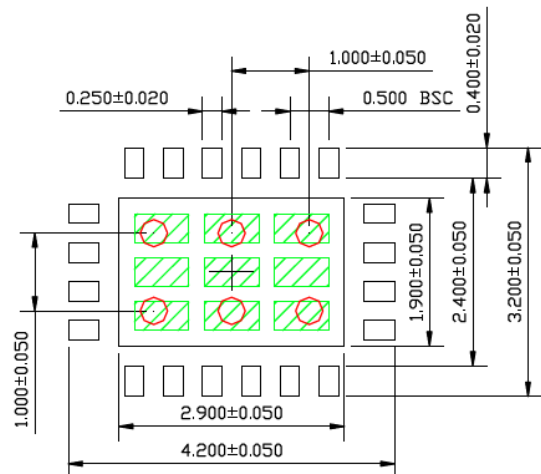
**RECOMMENDED LAND PATTERN**

NOTE: 4, 5

**NOTE:**

1. MAX PACKAGE WARPAGE IS 0.05 MM
2. MAX ALLOWABLE BURR IS 0.076MM IN ALL DIRECTIONS
3. PIN #1 IS ON TOP WILL BE LASER MARKED
4. RED CIRCLE IN LAND PATTERN INDICATE THERMAL VIA. SIZE SHOULD BE 0.30-0.3M IN DIAMETER AND SHOULD BE CONNECTED TO GND FOR MAX THERMAL PERFORMANCE
5. GREEN RECTANGLES (SHADED AREA) INDICATE SOLDER STENCIL OPENING ON EXPOSED PAD AREA. SIZE SHOULD BE 0.700x0.370 MM IN SIZE, 0.90 MM PITCH.

Note: For the most current package drawings, please see the Microchip Packaging Specification located at <http://www.microchip.com/packaging>.

**Package Outlines and Dimensions**

**TITLE**

20 LEAD QFN 5.0x3.2mm PACKAGE OUTLINE & RECOMMENDED LAND PATTERN

<b>DRAWING #</b>	QFN5032-20LD-PL-1	<b>UNIT</b>	MM
------------------	-------------------	-------------	----

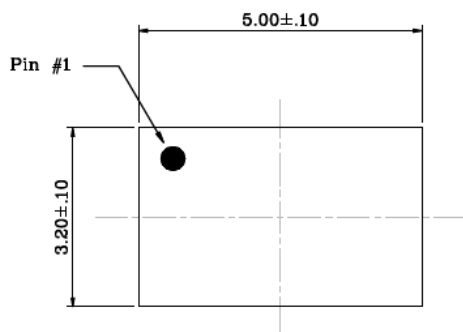

Top View

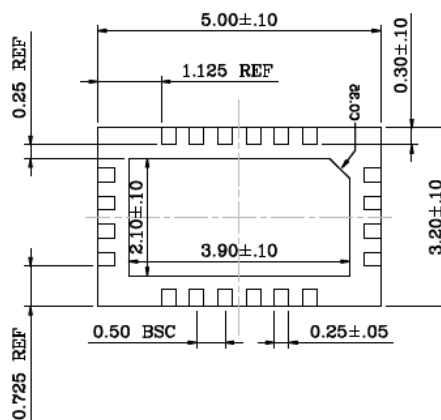

Bottom View



Side View

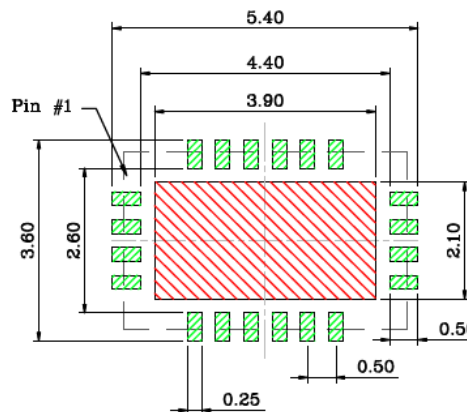

Recommended Land Pattern

**NOTE:**

1. Green shaded rectangles in Recommended Land Pattern are solder stencil opening.
2. Red shaded rectangle in Recommended Land Pattern is keep-out area.

Note: For the most current package drawings, please see the Microchip Packaging Specification located at <http://www.microchip.com/packaging>.

**Package Outlines and Dimensions**

**TITLE**

24 LEAD QFN 4x4mm PACKAGE OUTLINE & RECOMMENDED LAND PATTERN

<b>DRAWING #</b>	QFN44-24LD-PL-1	<b>UNIT</b>	MM
------------------	-----------------	-------------	----

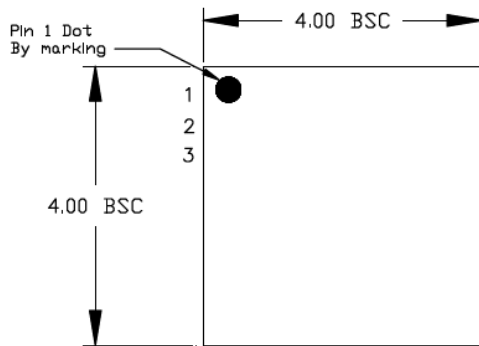

TOP VIEW  
NOTE: 1, 2, 3

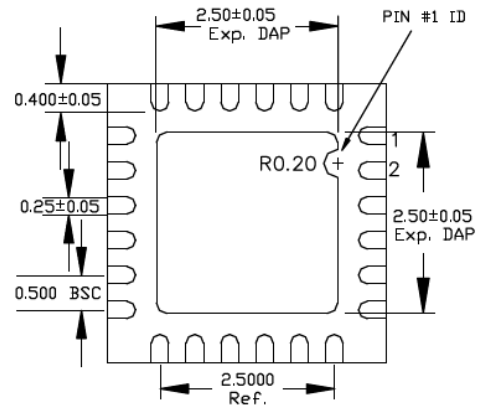

BOTTOM VIEW  
NOTE: 1, 2, 3

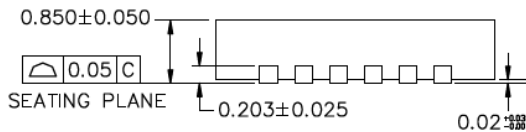

SIDE VIEW  
NOTE: 1, 2, 3

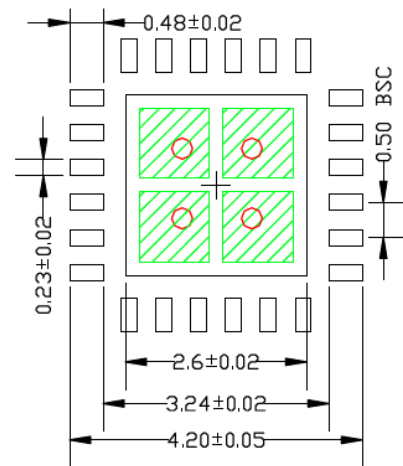

RECOMMENDED LAND PATTERN  
NOTE: 4, 5

- NOTE:
1. MAX PACKAGE WARPAGE IS 0.05 MM
  2. MAX ALLOWABLE BURR IS 0.076MM IN ALL DIRECTIONS
  3. PIN #1 IS ON TOP WILL BE LASER MARKED
  4. RED CIRCLE IN LAND PATTERN INDICATE THERMAL VIA. SIZE SHOULD BE 0.30-0.35M IN DIAMETER AND SHOULD BE CONNECTED TO GND FOR MAX THERMAL PERFORMANCE
  5. GREEN RECTANGLES (SHADED AREA) INDICATE SOLDER STENCIL OPENING ON EXPOSED PAD AREA. SIZE SHOULD BE 1.00x1.00 MM IN SIZE, 1.20 MM PITCH.

Note: For the most current package drawings, please see the Microchip Packaging Specification located at <http://www.microchip.com/packaging>.

## Package Outlines and Dimensions

**TITLE**

26 LEAD QFN 3mmx5mm PACKAGE OUTLINE & RECOMMENDED LAND PATTERN

<b>DRAWING #</b>   QFN35-26LD-PL-1	<b>UNIT</b>   MM
------------------------------------	------------------

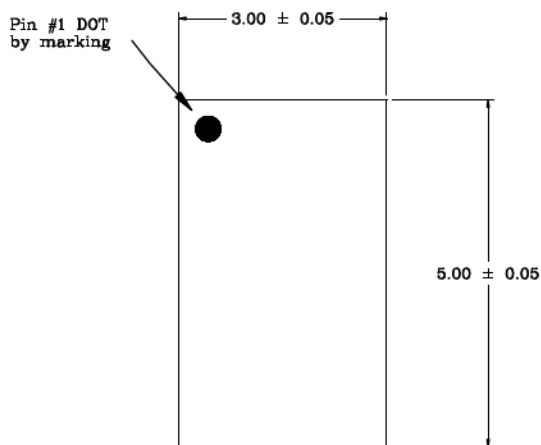

Top View

NOTE: 1,2,3

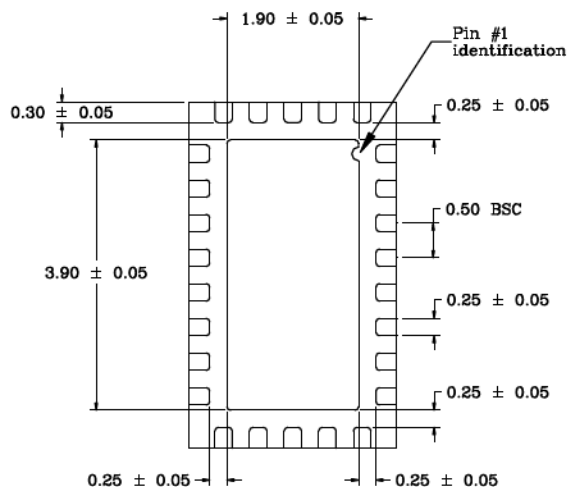

Bottom View

NOTE: 2,3

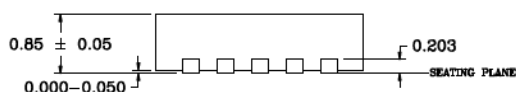

Side View

NOTE: 2,3

**NOTES:**

1. Top mark Pin #1 will be laser mark.
2. 0.05mm max package warpage.
3. Max allowable burr is 0.076mm in all directions.
4. Red color circles are thermal via. 0.30-0.35mm in diameter and 0.80mm pitch. Should be connected to GND for maximum performance.
5. Blue and Purple color pads represent different potential. Do not connect to GND.
6. Black color pads represent different IOs. Do not connect together.
7. Shaded rectangles (area) represents solder stencil opening on exposed metal trace.
8. Recommended Land Pattern Tolerance is  $\pm 0.020$ mm unless specified.
9. See recommended Land Pattern on page2.

Note: For the most current package drawings, please see the Microchip Packaging Specification located at <http://www.microchip.com/packaging>.



**Package Outlines and Dimensions**

POD-Land Pattern Doc #: QFN35-26LD-PL-1-B

**Recommended Land Pattern**

Note: 4,5,6,7

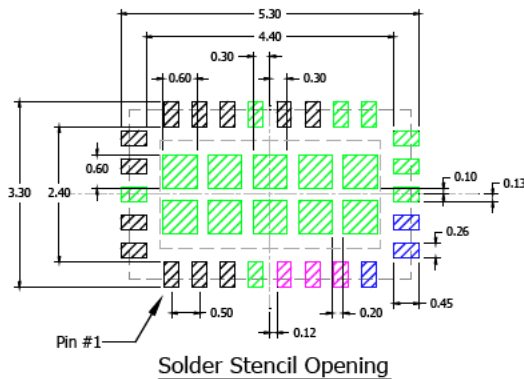
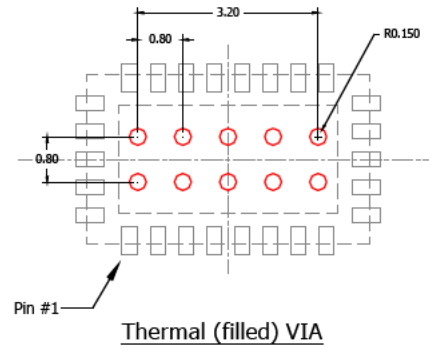
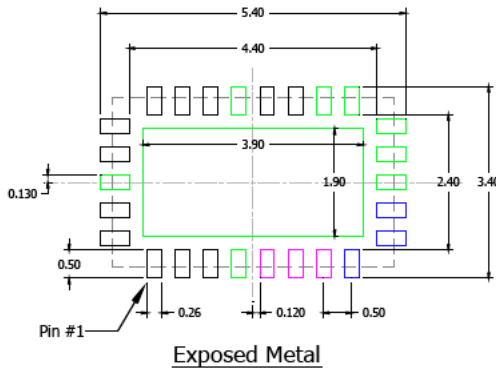
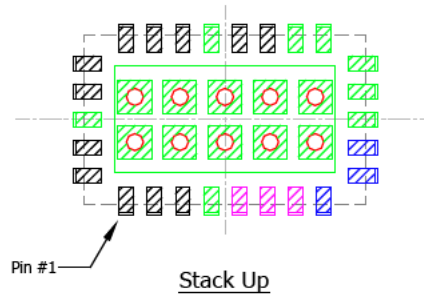

Note: For the most current package drawings, please see the Microchip Packaging Specification located at <http://www.microchip.com/packaging>.

**Package Outlines and Dimensions**

**TITLE**

28 LEAD QFN 4x4mm PACKAGE OUTLINE & RECOMMENDED LAND PATTERN

<b>DRAWING #</b>	QFN44-28LD-PL-1	<b>UNIT</b>	MM
------------------	-----------------	-------------	----

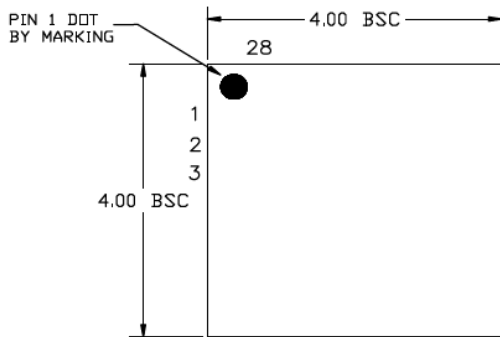

TOP VIEW

NOTE: 1, 2, 3

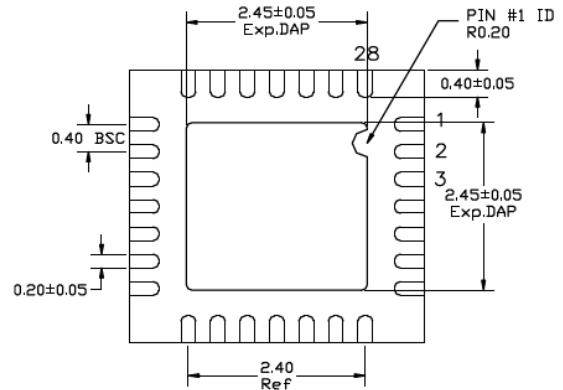

BOTTOM VIEW

NOTE: 1, 2, 3

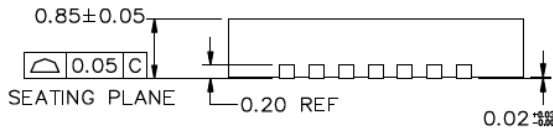

SIDE VIEW

NOTE: 1, 2, 3

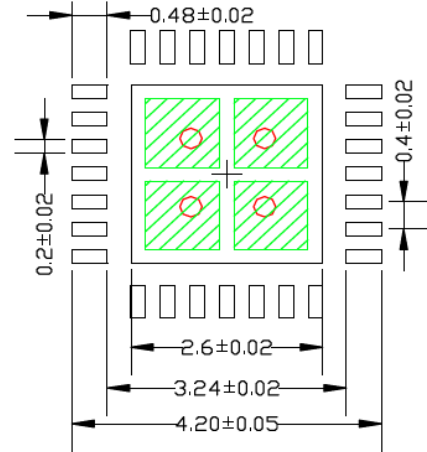

RECOMMENDED LAND PATTERN

NOTE: 4, 5

**NOTE:**

1. MAX PACKAGE WARPAGE IS 0.05 MM
2. MAX ALLOWABLE BURR IS 0.076MM IN ALL DIRECTIONS
3. PIN #1 IS ON TOP WILL BE LASER MARKED
4. RED CIRCLE IN LAND PATTERN INDICATE THERMAL VIA. SIZE SHOULD BE 0.30-0.3MM IN DIAMETER AND SHOULD BE CONNECTED TO GND FOR MAX THERMAL PERFORMANCE
5. GREEN RECTANGLES (SHADED AREA) INDICATE SOLDER STENCIL OPENING ON EXPOSED PAD AREA. SIZE SHOULD BE 1.00x1.00 MM IN SIZE, 1.20 MM PITCH.

Note: For the most current package drawings, please see the Microchip Packaging Specification located at <http://www.microchip.com/packaging>.

## Package Outlines and Dimensions

**TITLE**

28 LEAD QFN 4x5mm PACKAGE OUTLINE & RECOMMENDED LAND PATTERN

<b>DRAWING #</b>	QFN45-28LD-PL-1	<b>UNIT</b>	MM
<b>Lead Frame</b>	Copper Alloy	<b>Lead Finish</b>	Matte Tin

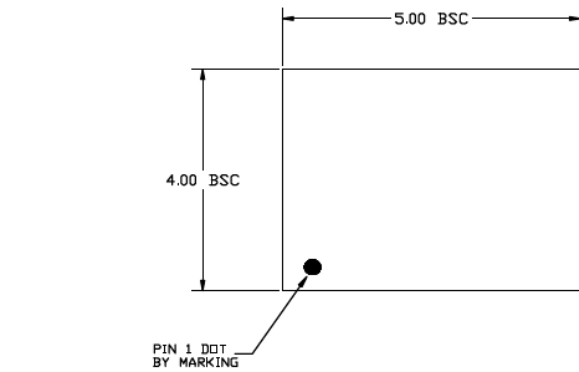

**TOP VIEW**  
NOTE: 1, 2, 3

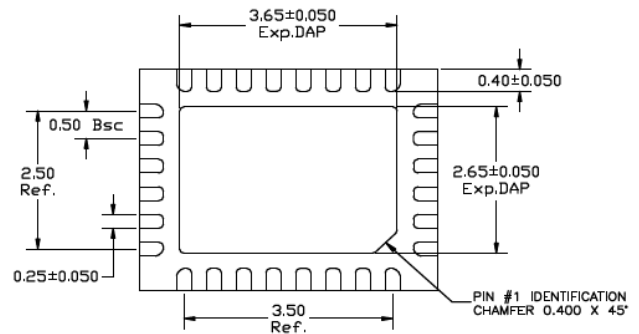

**BOTTOM VIEW**  
NOTE: 1, 2, 3

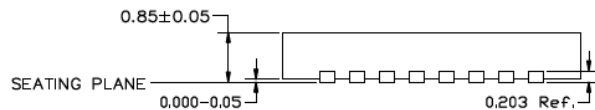

**SIDE VIEW**  
NOTE: 1, 2, 3

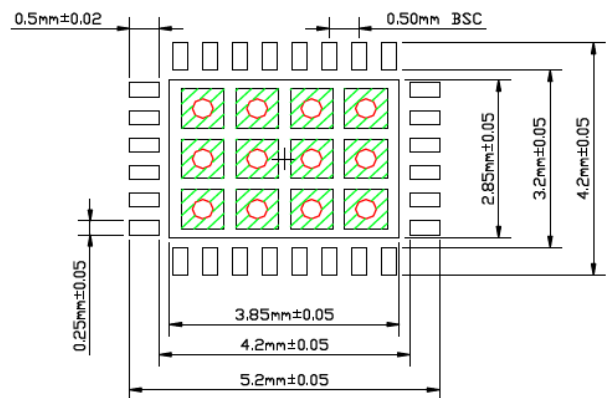

**RECOMMENDED LAND PATTERN**  
NOTE: 4, 5

**NOTE:**

1. MAX PACKAGE WARPAGE IS 0.05mm
2. MAX ALLOWABLE BURR IS 0.076mm IN ALL DIRECTIONS.
3. PIN #1 IS ON TOP WILL BE LASER MARKED.
4. RED CIRCLE IN LAND PATTERN INDICATES THERMAL VIA. SIZE SHOULD BE 0.30-0.35mm IN DIAMETER AND SHOULD BE CONNECTED TO GND FOR MAX THERMAL PERFORMANCE. 0.91mm Pitch.
5. GREEN RECTANGLES (SHADED AREA) INDICATE SOLDER STENCIL OPENING ON EXPOSED PAD AREA. SIZE SHOULD BE 0.71mmx0.71mm IN SIZE. 0.20mm Gap.

Note: For the most current package drawings, please see the Microchip Packaging Specification located at <http://www.microchip.com/packageing>.

## Package Outlines and Dimensions

### TITLE

28 LEAD QFN 5X6mm PACKAGE OUTLINE (Co-Package) & RECOMMENDED LAND PATTERN

<b>DRAWING #</b>	QFN56-28LD-PL-1	<b>UNIT</b>	MM
------------------	-----------------	-------------	----

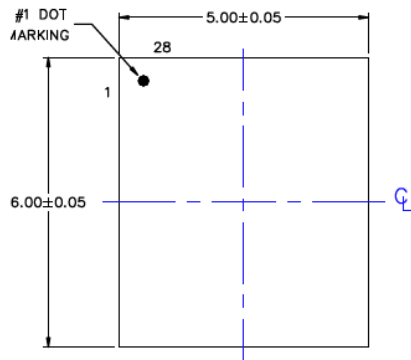

**TOP VIEW**  
NOTE: 1, 2, 3

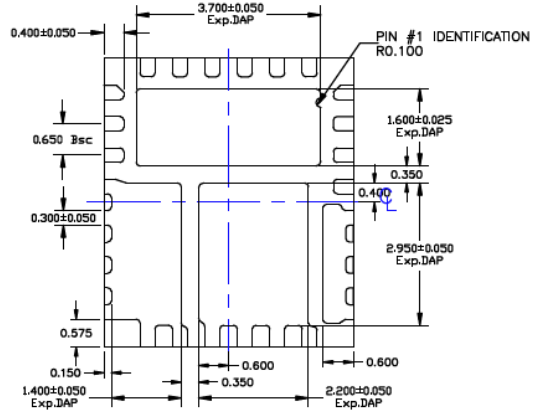

**BOTTOM VIEW**  
NOTE: 1, 2, 3

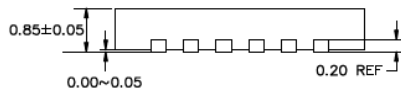

**SIDE VIEW**  
NOTE: 1, 2, 3

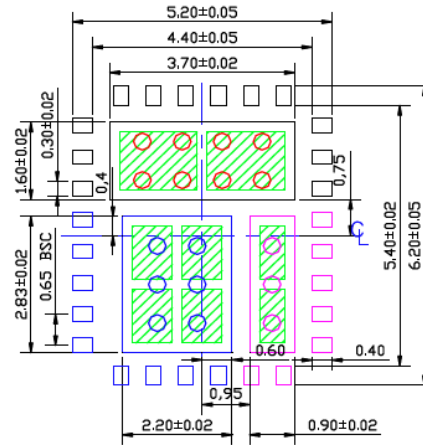

**RECOMMENDED LAND PATTERN**  
NOTE: 4, 5

#### NOTE:

1. MAX PACKAGE WARPAGE IS 0.05 MM
2. MAX ALLOWABLE BURR IS 0.076MM IN ALL DIRECTIONS
3. PIN #1 IS ON TOP WILL BE LASER MARKED
4. RED CIRCLES IN LAND PATTERN REPRESENT THERMAL VIA & SHOULD BE CONNECTED TO GND FOR MAXIMUM PERFORMANCE.
5. GREEN RECTANGLES (SHADED AREA) REPRESENT SOLDER STENCIL OPENING ON EXPOSED PAD AREA.
6. BLUE COLORED PADS & PURPLE COLORED PADS REPRESENT DIFFERENT POTENTIALS. DO NOT CONNECT TO GND.
7. RECOMMENDED SOLDER STENCIL OPENING AND VIA SIZES:

		Via size/Pitch	Solder stencil opening/Pitch	Comments
Red circle, black pad	Thermal Via	0 300-0 350mm/0 80mm	1 55x1 20mm/1 75mm	Must be connected to GND plane
Blue circle & pad		0 300-0 350mm/0 80mm	0 80x1 11mm/1 31mm	DO NOT connect to GND plane
Magenta circle & pad		0 300-0 350mm/0 80mm	0 50x1 11mm/1 31mm	DO NOT connect to GND plane

Note: For the most current package drawings, please see the Microchip Packaging Specification located at <http://www.microchip.com/packaging>.

## Package Outlines and Dimensions

**TITLE**

28 LEAD QFN 5X6mm PACKAGE (Co-Package) OUTLINE &amp; RECOMMENDED LAND PATTERN

<b>DRAWING #</b>	QFN56-28LD-PL-2	<b>UNIT</b>	MM
<b>Lead Frame</b>	NiPdAu	<b>Lead Finish</b>	NiPdAu

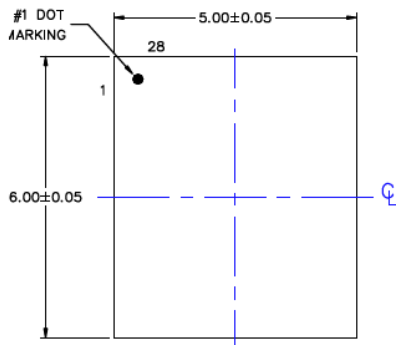

**TOP VIEW**  
NOTE: 1, 2, 3

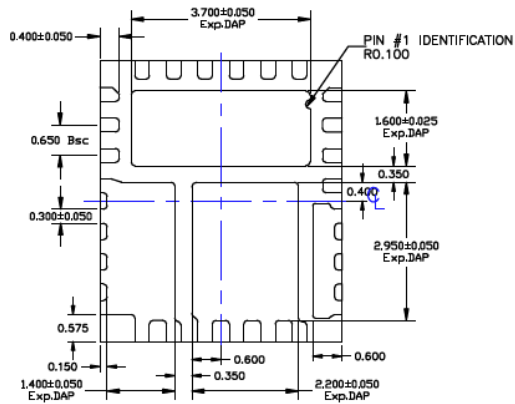

**BOTTOM VIEW**  
NOTE: 1, 2, 3

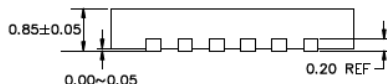

**SIDE VIEW**  
NOTE: 1, 2, 3

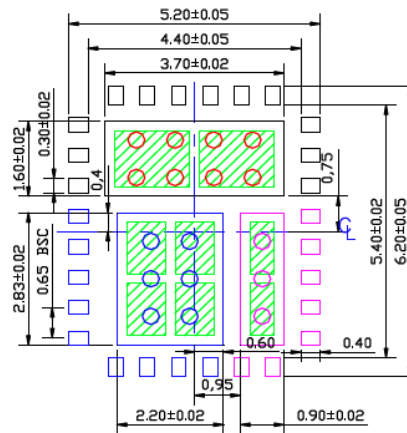

**RECOMMENDED LAND PATTERN**  
NOTE: 4, 5

**NOTE:**

1. MAX PACKAGE WARPAGE IS 0.05 MM
2. MAX ALLOWABLE BURR IS 0.076MM IN ALL DIRECTIONS
3. PIN #1 IS ON TOP WILL BE LASER MARKED
4. RED CIRCLES IN LAND PATTERN REPRESENT THERMAL VIA & SHOULD BE CONNECTED TO GND FOR MAXIMUM PERFORMANCE.
5. GREEN RECTANGLES (SHADED AREA) REPRESENT SOLDER STENCIL OPENING ON EXPOSED PAD AREA
6. BLUE COLORED PADS & PURPLE COLORED PADS REPRESENT DIFFERENT POTENTIALS. DO NOT CONNECT TO GND.
7. RECOMMENDED SOLDER STENCIL OPENING AND VIA SIZES

		Via size/Pitch	Solder stencil opening/Pitch	Comments
Red circle, black pad	Thermal Via	0.300-0.350mm/0.80mm	1.55x1.20mm/1.75mm	Must be connected to GND plane
Blue circle & pad		0.300-0.350mm/0.80mm	0.80x1.11mm/1.31mm	DO NOT connect to GND plane
Magenta circle & pad		0.300-0.350mm/0.80mm	0.50x1.11mm/1.31mm	DO NOT connect to GND plane

Note: For the most current package drawings, please see the Microchip Packaging Specification located at <http://www.microchip.com/packaging>.

## Package Outlines and Dimensions

### TITLE

30 LEAD QFN 5X6mm PACKAGE (Co-Package) OUTLINE & RECOMMENDED LAND PATTERN

DRAWING #	UNIT	MM
QFN56-30LD-PL-1		

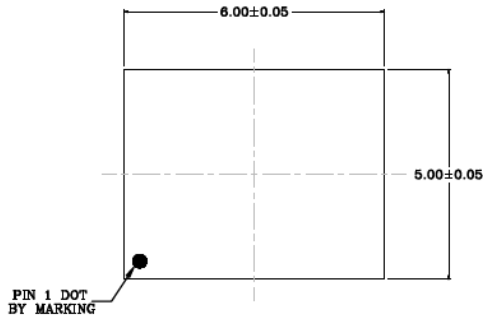

**TOP VIEW**  
NOTE: 1, 2, 8

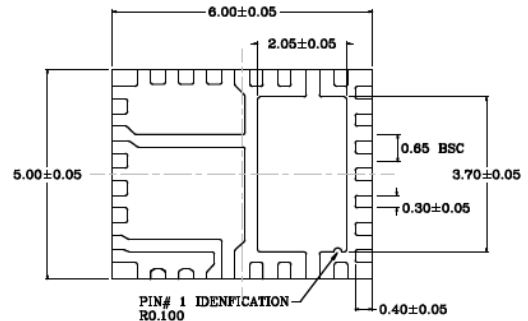

**BOTTOM VIEW**  
NOTE: 2, 3

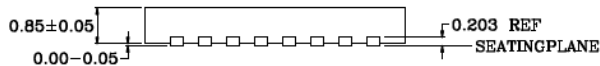

**SIDE VIEW**  
NOTE: 2, 3

### NOTE:

1. Top mark Pin #1 will be laser mark.
2. 0.05mm max package warpage.
3. Max allowable burr is 0.076mm in all directions.
4. Red, Purple, and Blue color circles are thermal via. 0.30-0.35mm in diameter and 0.80mm pitch. Red circles should be connected to GND for maximum performance.
5. Blue & Magenta color pads represent different potential. Do not connect to GND.
6. Green rectangles (shaded area) represents solder stencil opening on exposed metal trace.
7. Recommended Land Pattern Tolerance is  $\pm 0.020$ mm unless specified.
8. See recommended land pattern on page2.

Note: For the most current package drawings, please see the Microchip Packaging Specification located at <http://www.microchip.com/packaging>.

**Package Outlines and Dimensions**

POD-Land Pattern Doc #: QFN56-30LD-PL-1-A

**Recommended Land Pattern**

Note: 4,5,6,7

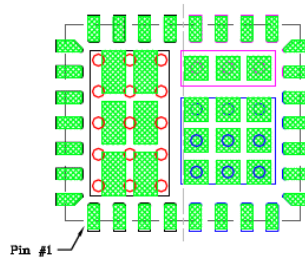

**Stacked Up**

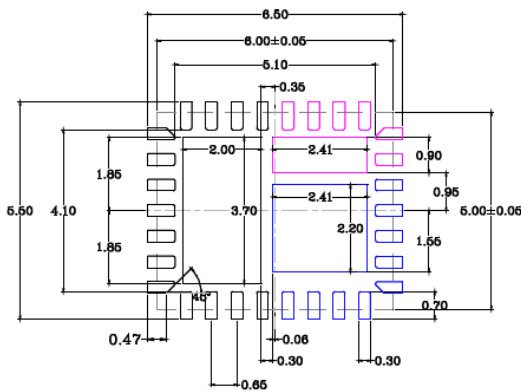

**Exposed Metal Trace**

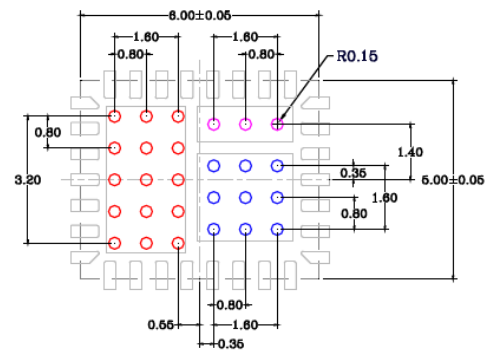

**Thermal (filled) Via**

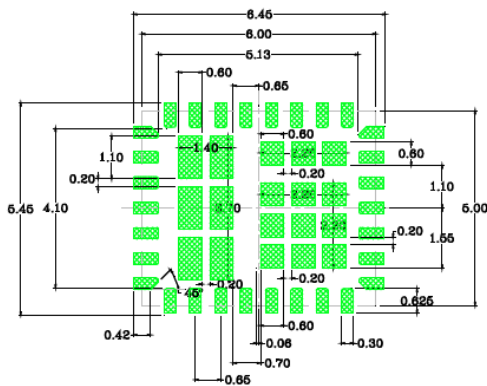

**Solder Stencil Opening**

Note: For the most current package drawings, please see the Microchip Packaging Specification located at <http://www.microchip.com/packaging>.

## Package Outlines and Dimensions

### TITLE

32 LEAD QFN PACKAGE OUTLINE & RECOMMENDED LAND PATTERN

<b>DRAWING #</b>	QFN44-32LD-PL-1	<b>UNIT</b>	MM
<b>Lead Frame</b>	NiPdAu	<b>Lead Finish</b>	NiPdAu

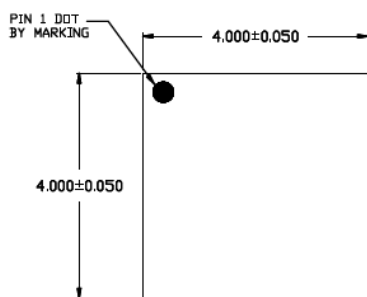

**TOP VIEW**  
NOTE: 1, 2, 3

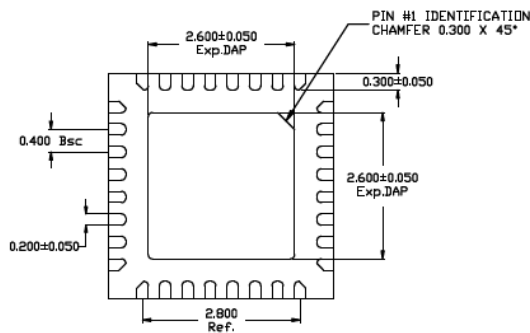

**BOTTOM VIEW**  
NOTE: 1, 2, 3

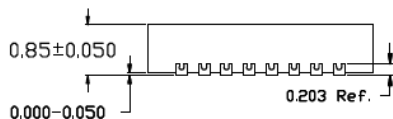

**SIDE VIEW**  
NOTE: 1, 2, 3

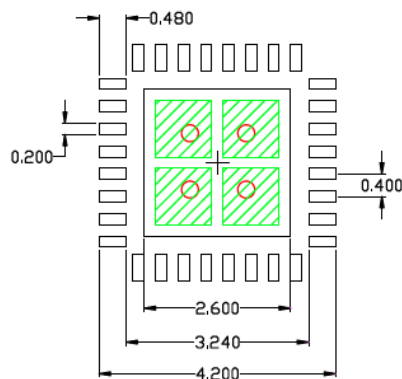

**RECOMMENDED LAND PATTERN**  
NOTE: 4, 5, 6

**NOTE:**

1. MAX PACKAGE WARPAGE IS 0.05 MM
2. MAX ALLOWABLE BURR IS 0.076MM IN ALL DIRECTIONS
3. PIN #1 IS ON TOP WILL BE LASER MARKED
4. RED CIRCLE IN LAND PATTERN INDICATE THERMAL VIA. SIZE SHOULD BE 0.30-0.3M IN DIAMETER AND SHOULD BE CONNECTED TO GND FOR MAX THERMAL PERFORMANCE
5. GREEN RECTANGLES (SHADED AREA) INDICATE SOLDER STENCIL OPENING ON EXPOSED PAD AREA. SIZE SHOULD BE 1.00x1.00 MM IN SIZE, 1.20 MM PITCH.
6. TOLERANCE ±0.02 MM.

Note: For the most current package drawings, please see the Microchip Packaging Specification located at <http://www.microchip.com/packaging>.



## Package Outlines and Dimensions

**TITLE**

32 LEAD QFN 5x5mm PACKAGE OUTLINE & RECOMMENDED LAND PATTERN

<b>DRAWING #</b>	QFN55-32LD-PL-1	<b>UNIT</b>	MM
------------------	-----------------	-------------	----

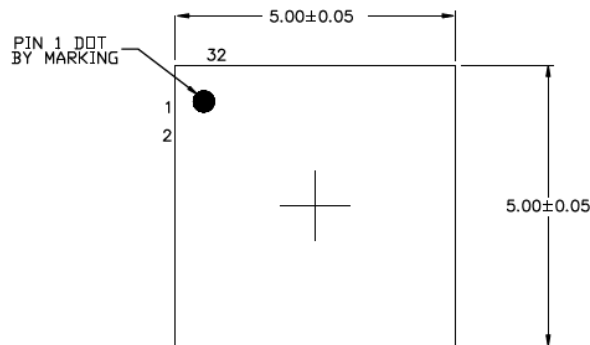

**TOP VIEW**  
NOTE: 1, 2, 3

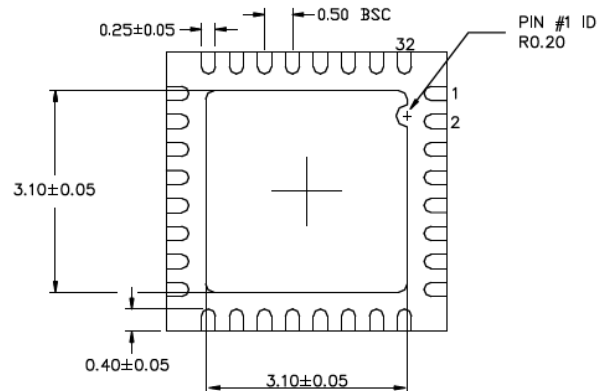

**BOTTOM VIEW**  
NOTE: 1, 2, 3

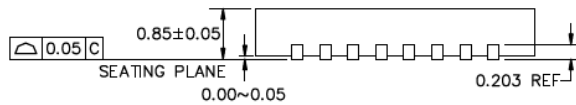

**SIDE VIEW**  
NOTE: 1, 2, 3

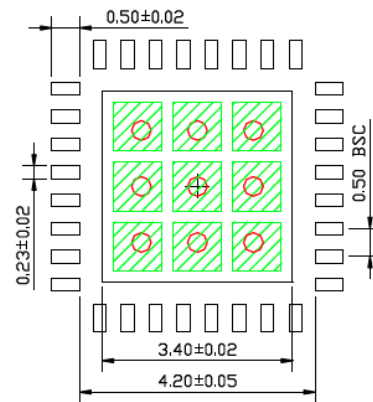

**RECOMMENDED LAND PATTERN**  
NOTE: 4, 5

**NOTE:**

1. MAX PACKAGE WARPAGE IS 0.05 MM
2. MAX ALLOWABLE BURR IS 0.076MM IN ALL DIRECTIONS
3. PIN #1 IS ON TOP WILL BE LASER MARKED
4. RED CIRCLE IN LAND PATTERN INDICATE THERMAL VIA. SIZE SHOULD BE 0.30-0.35MM IN DIAMETER AND SHOULD BE CONNECTED TO GND FOR MAX THERMAL PERFORMANCE
5. GREEN RECTANGLES (SHADED AREA) INDICATE SOLDER STENCIL OPENING ON EXPOSED PAD AREA. SIZE SHOULD BE 0.87x0.87 MM IN SIZE, 1.07 MM PITCH.

Note: For the most current package drawings, please see the Microchip Packaging Specification located at <http://www.microchip.com/packaging>.

**Package Outlines and Dimensions**

**TITLE**

32 LEAD QFN 5x5mm PACKAGE OUTLINE & RECOMMENDED LAND PATTERN

DRAWING #	QFN55-32LD-PL-2	UNIT	MM
-----------	-----------------	------	----

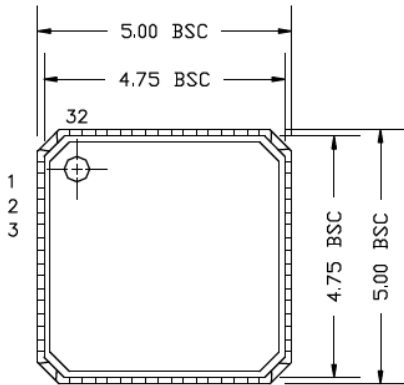

TOP VIEW

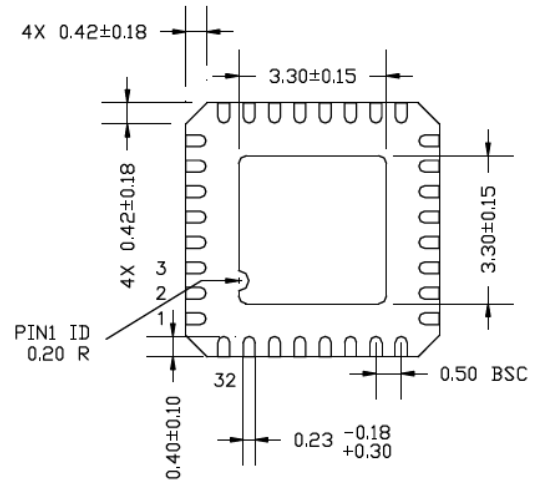

BOTTOM VIEW

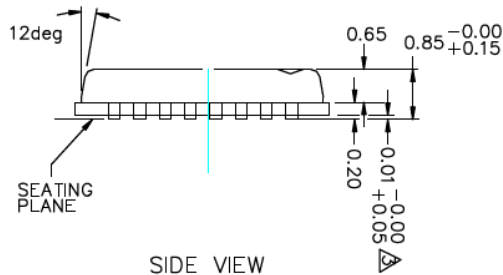

SIDE VIEW

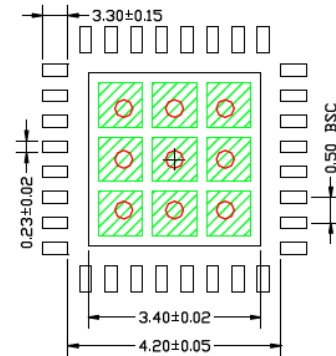

RECOMMENDED LAND PATTERN  
NOTE 4, 5

**NOTES:**

1. THE PIN#1 IDENTIFIER MUST EXIST ON THE TOP SURFACE OF PACKAGE USING IDENTIFICATION MARK OR OTHER FEATURE OF PACKAGE BODY.
2. PACKAGE WRAPAGE MAX 0.05MM.
3. APPLIES TO EXPOSED PAD AND TERMINALS.
4. RED CIRCLE IN LAND PATTERN INDICATE THERMAL VIA. SIZE SHOULD BE 0.30-0.3M IN DIAMETER AND SHOULD BE CONNECTED TO GND FOR MAX THERMAL PERFORMANCE
5. GREEN RECTANGLES (SHADED AREA) INDICATE SOLDER STENCIL OPENING ON EXPOSED PAD AREA. SIZE SHOULD BE 0.87x0.87 MM IN SIZE, 1.07 MM PITCH.

Note: For the most current package drawings, please see the Microchip Packaging Specification located at <http://www.microchip.com/packaging>.

## Package Outlines and Dimensions

**TITLE**

32 LEAD QFN 5x5mm PACKAGE OUTLINE &amp; RECOMMENDED LAND PATTERN

<b>DRAWING #</b>	QFN55-32LD-PL-5	<b>UNIT</b>	MM
<b>LEAD FRAME</b>	NiPdAu	<b>LEAD FINISH</b>	NiPdAu

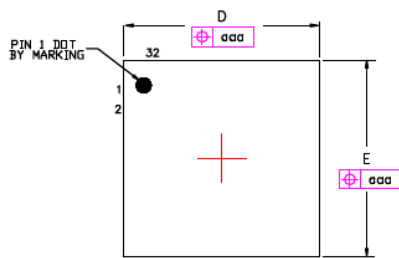
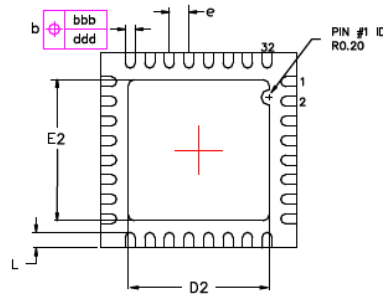
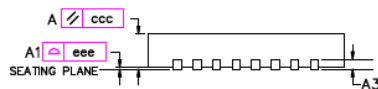
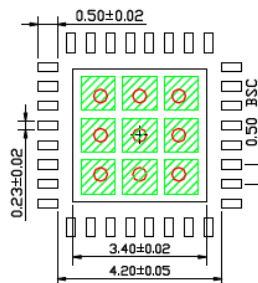
**TOP VIEW**  
NOTE: 9, 10

**BOTTOM VIEW**  
NOTE: 9, 10

**SIDE VIEW**  
NOTE: 9, 10

**RECOMMENDED LAND PATTERN**  
NOTE: 11, 12

SYMBOL	DIMENSION IN mm		
	MIN	NOM	MAX
A	0.80	0.85	1.00
A1	0.00	0.02	0.05
A3	0.20 (REF)		
D	5.00 BSC		
D2	3.00	3.10	3.20
E	5.00 BSC		
E2	3.00	3.10	3.20
L	0.35	0.40	0.45

N	b (mm)			e (mm)		
	MIN	NOM	MAX	MIN	NOM	MAX
32	0.18	0.25	0.30	0.50 BSC		

TOLERANCE OF FORM AND POSITION	
aaa	0.15
bbb	0.10
ccc	0.10
ddd	0.05
eee	0.08

**NOTE:**

1. REFER TO JEDEC STANDARD MO-220 VHD-2.
2. DIMENSION "b" APPLIES TO METALIZED TERMINAL AND IS MEASURED BETWEEN 0.15mm TO 0.30mm FROM THE TERMINAL TIP.
3. "aaa" THE BILATERAL PROFILE TOLERANCE THAT CONTROLS THE POSITION OF THE PLASTIC BODY SIDES. THE CENTERS OF THE PROFILE ZONES ARE DEFINED BY THE BASIC DIMENSIONS "D" AND "E".
4. "bbb" THE TOLERANCE THAT CONTROLS THE POSITION OF THE ENTIRE TERMINAL PATTERN WITH RESPECT TO DATUM'S A AND B. THE CENTER OF THE TOLERANCE ZONE OF EACH TERMINAL IS DEFINED BY THE BASIC DIMENSION "e" AS RELATED TO DATUM A AND B.
5. "ccc" THE TOLERANCE LOCATED PARALLEL TO THE SEATING PLANE IN WHICH THE TOP SURFACE OF THE PACKAGE MUST BE LOCATED.
6. "ddd" THE TOLERANCE THAT CONTROLS THE POSITION OF THE TERMINALS TO EACH OTHER. THE CENTERS OF THE PROFILE ZONES ARE DEFINED BY BASIC DIMENSION "e".
7. "eee" THE UNILATERAL TOLERANCE LOCATED ABOVE THE SEATING PLANE WHEREIN THE BOTTOM SURFACE OF THE TERMINALS MUST BE LOCATED.
8. THE TOLERANCE THAT CONTROLS THE POSITION OF THE EXPOSED METAL HEAT FEATURE. THE CENTER OF THE TOLERANCE ZONE WILL BE THE DATUM'S DEFINED BY THE CENTERLINES OF THE PACKAGE BODY.
9. MAX PACKAGE WARPAGE IS 0.05 MM.
10. PIN #1 IS ON TOP WILL BE LASER MARKED.
11. RED CIRCLE IN LAND PATTERN INDICATE THERMAL VIA. SIZE SHOULD BE 0.30-0.35MM IN DIAMETER AND SHOULD BE CONNECTED TO GND FOR MAX THERMAL PERFORMANCE.
12. GREEN RECTANGLES (SHADED AREA) INDICATE SOLDER STENCIL OPENING ON EXPOSED PAD AREA. SIZE SHOULD BE 0.87x0.87 MM IN SIZE, 1.07 MM PITCH.
13. THIS DOCUMENT IS FOR AUTOMOTIVE PRODUCT USE ONLY.

Note: For the most current package drawings, please see the Microchip Packaging Specification located at <http://www.microchip.com/packaging>.

## Package Outlines and Dimensions

### TITLE

40 LEAD QFN 6x6mm PACKAGE OUTLINE & RECOMMENDED LAND PATTERN

DRAWING #	UNIT	MM
QFN66-40LD-PL-1		

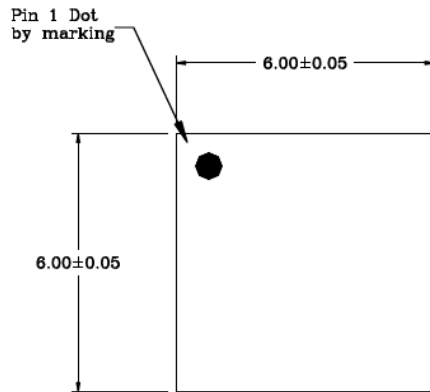

Top View

NOTE: 1,2,3

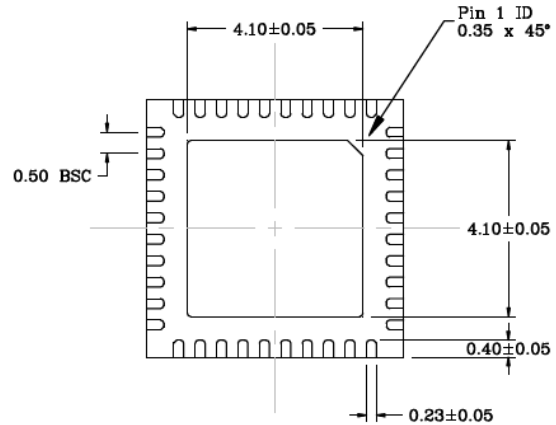

Bottom View

NOTE: 2,3

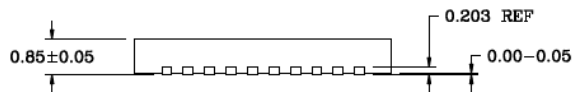

Side View

NOTE: 2,3

### NOTES:

1. Top mark Pin #1 will be laser mark.
2. 0.05mm max package warpage.
3. Max allowable burr is 0.076mm in all directions.
4. Red color circles are thermal via. 0.30-0.35mm in diameter and 1.20mm pitch. Should be connected to GND for maximum performance.
5. Black color pads represent different IOs. Do not connect together.
6. Green shaded rectangles (area) represents solder stencil opening on exposed metal trace.
7. Recommended Land Pattern Tolerance is  $\pm 0.020$ mm unless specified.
8. See recommended Land Pattern on page 2.

Note: For the most current package drawings, please see the Microchip Packaging Specification located at <http://www.microchip.com/packaging>.

**Package Outlines and Dimensions**

POD-Land Pattern Doc #: QFN66-40LD-PL-1

**Recommended Land Pattern**

Note: 4,5,6,7

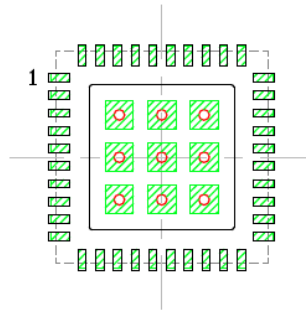

Stack Up

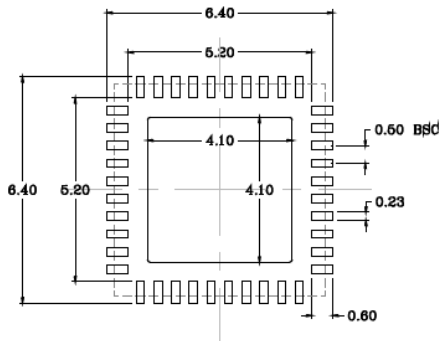

Exposed Metal

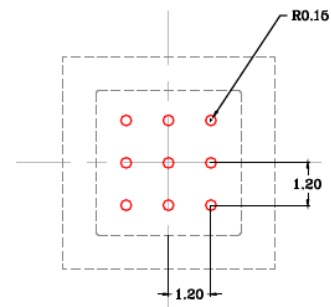

Thermal (filled) VIA

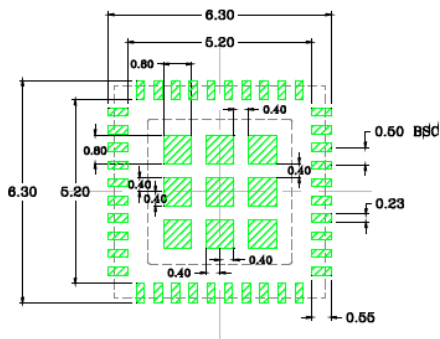

Solder Stencil Opening

Note: For the most current package drawings, please see the Microchip Packaging Specification located at <http://www.microchip.com/packaging>.

## Package Outlines and Dimensions

### TITLE

44 LEAD QFN 7x7mm PACKAGE OUTLINE & RECOMMENDED LAND PATTERN

DRAWING #	QFN77-44LD-PL-1	UNIT	MM
-----------	-----------------	------	----

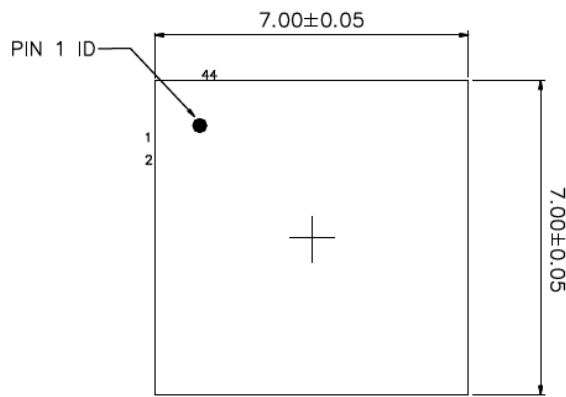

**TOP VIEW**  
NOTE: 1, 2, 3

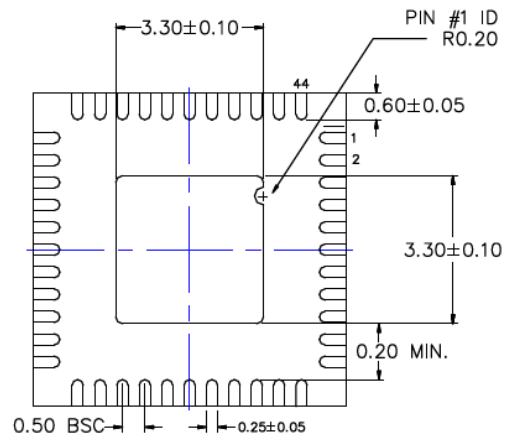

**BOTTOM VIEW**  
NOTE: 1, 2, 3

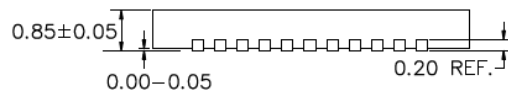

**SIDE VIEW**  
NOTE: 1, 2, 3

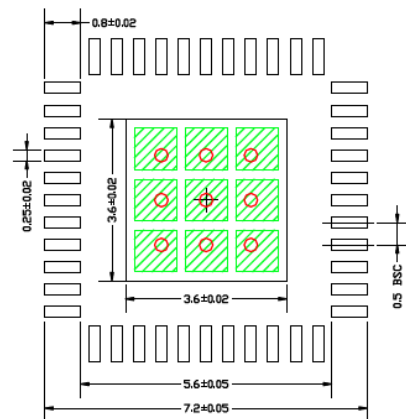

**RECOMMENDED LAND PATTERN**  
NOTE: 4, 5

#### NOTE:

1. MAX PACKAGE WARPAGE IS 0.05 MM
2. MAX ALLOWABLE BURR IS 0.076MM IN ALL DIRECTIONS
3. PIN #1 IS ON TOP WILL BE LASER MARKED
4. RED CIRCLE IN LAND PATTERN INDICATE THERMAL VIA. SIZE SHOULD BE 0.30-0.35MM IN DIAMETER AND SHOULD BE CONNECTED TO GND FOR MAX THERMAL PERFORMANCE, 1.0MM PITCH
5. GREEN RECTANGLES (SHADED AREA) REPRESENT SOLDER STENCIL OPENING ON EXPOSED PAD AREA. RECOMMENDED SIZE IS 0.93x0.93MM, SPACING IS 0.2MM

Note: For the most current package drawings, please see the Microchip Packaging Specification located at <http://www.microchip.com/packaging>.

---



---

## Package Outlines and Dimensions

---



---

**TITLE**

48 LEAD QFN 7x7mm PACKAGE OUTLINE &amp; RECOMMENDED LAND PATTERN

DRAWING #	QFN77-48LD-PL-1	UNIT	MM
-----------	-----------------	------	----

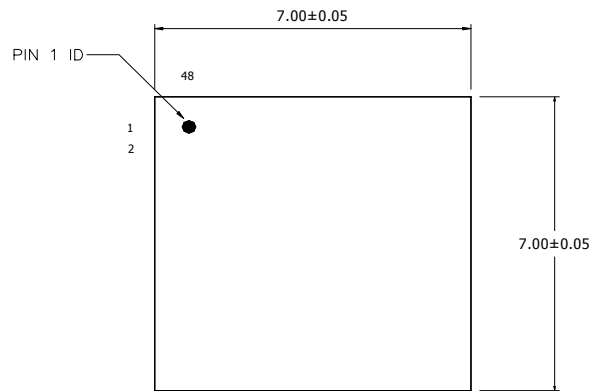
**Top View**

NOTE: 1, 2, 3

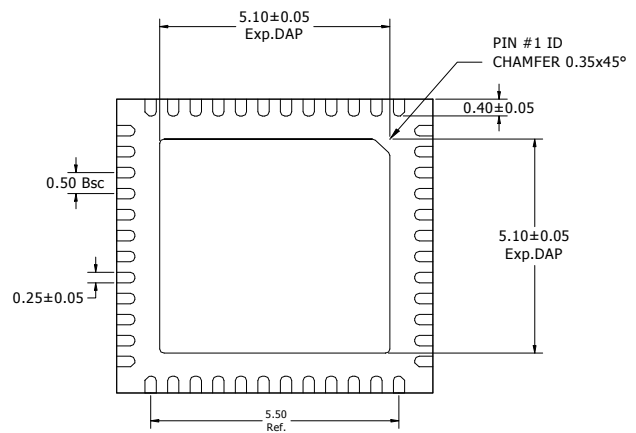
**Bottom View**

NOTE: 1, 2, 3

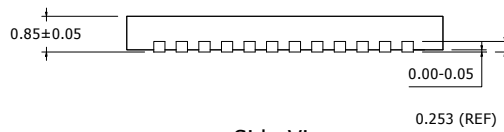
**Side View**

NOTE: 1, 2, 3

**NOTE :**

1. MAX PACKAGE WARPAGE IS 0.05mm.
2. MAX ALLOWABLE BURR IS 0.076mm IN ALL DIRECTIONS.
3. PIN #1 IS ON TOP WILL BE LASER MARKED.
4. RED CIRCLE IN LAND PATTERN INDICATES THERMAL VIA. SIZE SHOULD BE 0.30-0.35mm IN DIAMETER AND SHOULD BE CONNECTED TO GND FOR MAX THERMAL PERFORMANCE. PITCH IS 1.00mm.
5. GREEN RECTANGLES (SHADED AREA) REPRESENT SOLDER STENCIL OPENING ON EXPOSED PAD AREA. RECOMMENDED SIZE IS 1.00x1.00mm, SPACING IS 0.25mm.

Note: For the most current package drawings, please see the Microchip Packaging Specification located at <http://www.microchip.com/packaging>.

**Package Outlines and Dimensions**

POD-Land Pattern drawing #: QFN77-48LD-PL-1-C

RECOMMENDED LAND PATTERN

NOTE: 4, 5

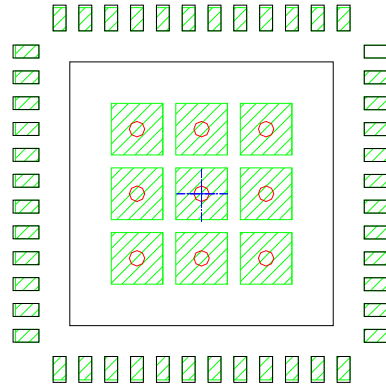

STACKED-UP

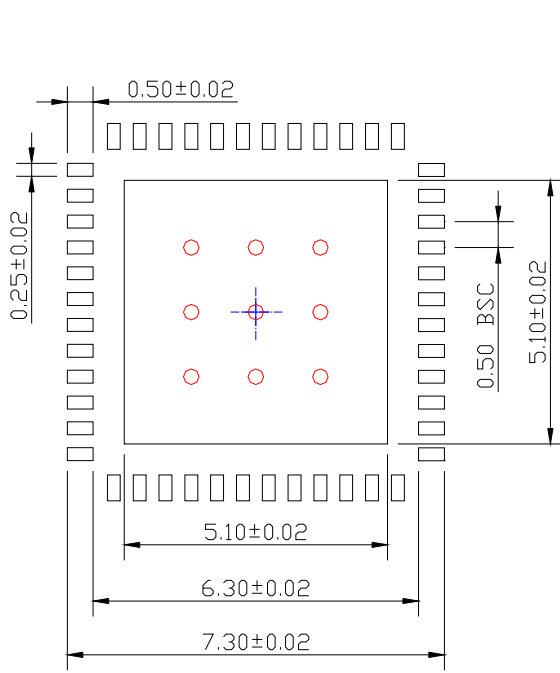

EXPOSED METAL TRACE

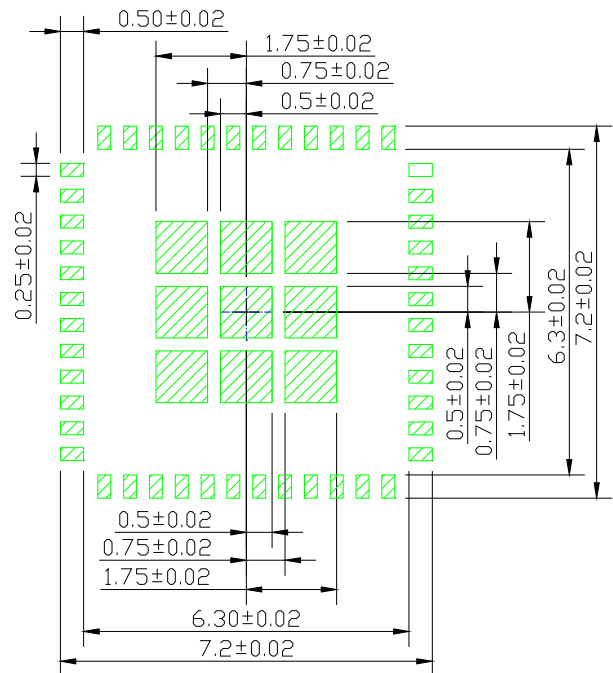

SOLDER STENCIL OPENING

Note: For the most current package drawings, please see the Microchip Packaging Specification located at <http://www.microchip.com/packaging>.



## Package Outlines and Dimensions

**TITLE**

48 LEAD QFN 7x7mm PACKAGE OUTLINE & RECOMMENDED LAND PATTERN

<b>DRAWING #</b>	QFN77-48LD-PL-2	<b>UNIT</b>	MM
------------------	-----------------	-------------	----

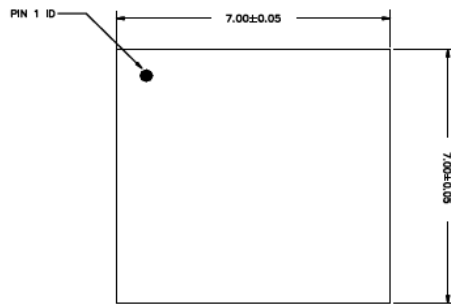

**TOP VIEW**  
NOTE 1, 2, 3

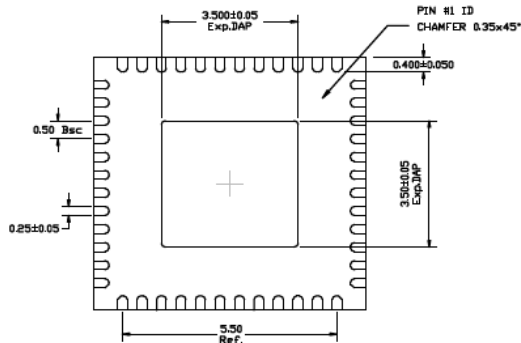

**BOTTOM VIEW**  
NOTE 1, 2, 3

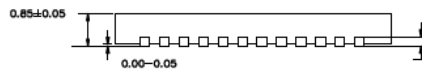

**SIDE VIEW**  
NOTE 1, 2, 3

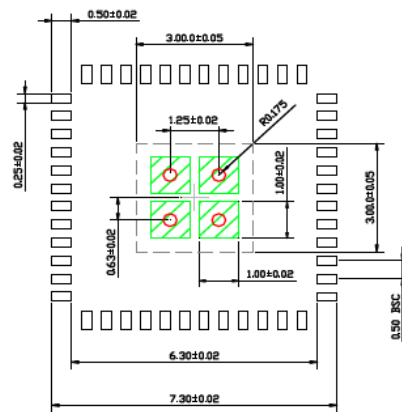

**RECOMMENDED LAND PATTERN**  
NOTE 4, 5

**NOTE:**

1. MAX PACKAGE WARPAGE IS 0.05mm
2. MAX ALLOWABLE BURR IS 0.076mm IN ALL DIRECTIONS.
3. PIN #1 IS ON TOP WILL BE LASER MARKED
4. **RED** CIRCLE IN LAND PATTERN INDICATES THERMAL VIA. SIZE SHOULD BE 0.30-0.35mm IN DIAMETER AND SHOULD BE CONNECTED TO GND FOR MAX THERMAL PERFORMANCE. PITCH IS 1.25mm.
5. **GREEN** RECTANGLES (SHADED AREA) REPRESENT SOLDER STENCIL OPENING ON EXPOSED PAD AREA. RECOMMENDED SIZE IS 1.00mm x 1.00mm, SPACING IS 0.25mm, PITCH IS 1.25mm.

Note: For the most current package drawings, please see the Microchip Packaging Specification located at <http://www.microchip.com/packaging>.

## Package Outlines and Dimensions

### TITLE

56 LEAD QFN 8.0x8.0mm PACKAGE OUTLINE & RECOMMENDED LAND PATTERN

<b>DRAWING #</b>	QFN88-56LD-PL-1	<b>UNIT</b>	MM
<b>Lead Frame Type</b>	AgCu	<b>Lead Finish</b>	Matte Tin

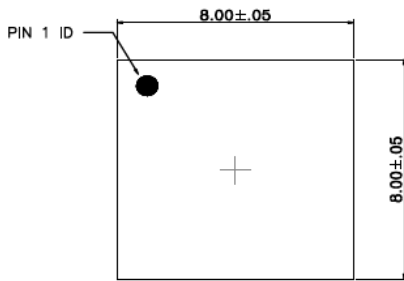

**TOP VIEW**  
NOTE: 1, 2, 3

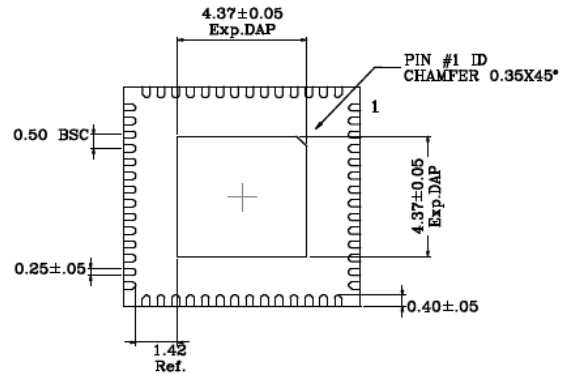

**BOTTOM VIEW**  
NOTE: 1, 2, 3



**SIDE VIEW**  
NOTE: 1, 2, 3

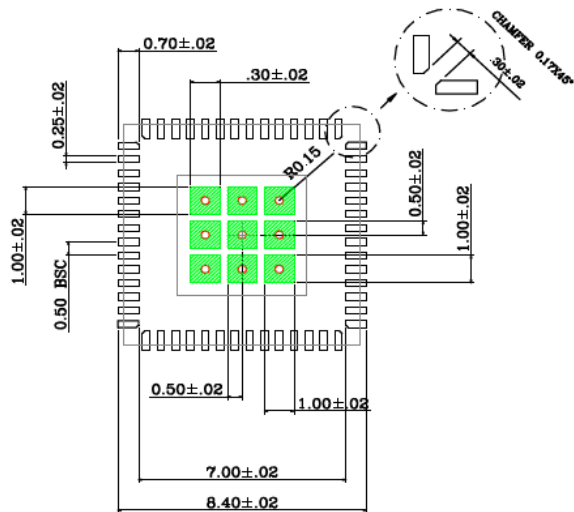

**RECOMMENDED LAND PATTERN**  
NOTE: 4, 5

### NOTE:

1. MAX PACKAGE WARPAGE IS 0.05mm.
2. MAX ALLOWABLE BURR IS 0.076mm IN ALL DIRECTIONS.
3. PIN #1 IS ON TOP WILL BE LASER MARK.
4. RED CIRCLES IN LAND PATTERN INDICATES THERMAL VIA. SIZE SHOULD BE 0.30-0.35mm IN DIAMETER AND SHOULD BE CONNECTED TO GND FOR MAX THERMAL PERFORMANCE. PITCH IS 1.25mm.
5. GREEN RECTANGLES (SHADED AREA) REPRESENT SOLDER STENCIL OPENING ON EXPOSED PAD AREA. RECOMMENDED SIZE IS 1.0x1.0mm, SPACING IS 0.25mm.

Note: For the most current package drawings, please see the Microchip Packaging Specification located at <http://www.microchip.com/packaging>.

## Package Outlines and Dimensions

**TITLE**

64 LEAD QFN 8x8mm PACKAGE OUTLINE & RECOMMENDED LAND PATTERN

<b>DRAWING #</b>	QFN88-64LD-PL-1	<b>UNIT</b>	MM
------------------	-----------------	-------------	----

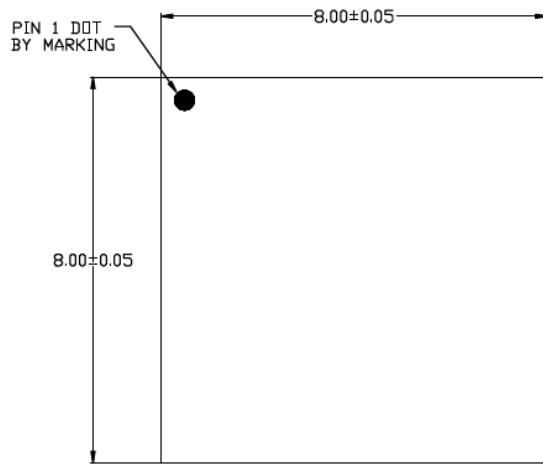

TOP VIEW  
NOTE : 1,2,3,4

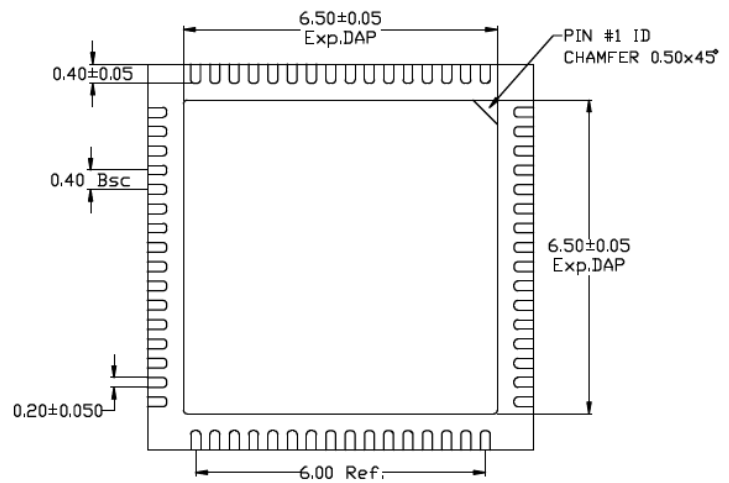

BOTTOM VIEW  
NOTE : 1,2,3,4,5

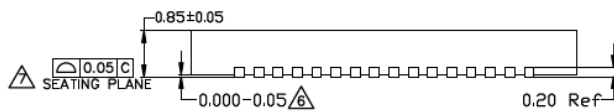

SIDE VIEW  
NOTE : 1,2,3,4,5,6,7

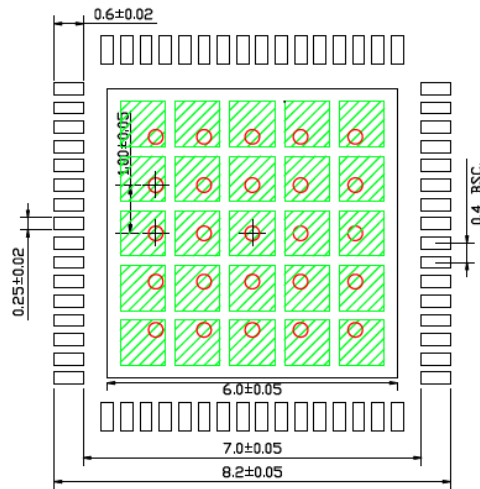

RECOMMENDED LAND PATTERN  
NOTE : 8,9

**NOTE:**

1. ALL DIMENSIONS ARE IN MILLIMETERS.
2. MAX. PACKAGE WARPAGE IS 0.05 mm.
3. MAXIMUM ALLOWABLE BURRS IS 0.076 mm IN ALL DIRECTIONS.
4. PIN #1 ID ON TOP WILL BE LASER/INK MARKED.
- △ DIMENSION APPLIES TO METALIZED TERMINAL AND IS MEASURED BETWEEN 0.20 AND 0.25 mm FROM TERMINAL TIP.
- △ APPLIED ONLY FOR TERMINALS.
- △ APPLIED FOR EXPOSED PAD AND TERMINALS.
8. RED CIRCLE INDICATES THERMAL VIA. SIZE SHOULD BE 0.300-0.350mm IN DIAMETER AND IT SHOULD BE CONNECTED TO GND PLANE FOR MAXIMUM THERMAL PERFORMANCE.
9. GREEN RECTANGLE (WITH SHADED AREA) INDICATES SOLDER STENCIL OPENING ON EXPOSED PAD AREA. SIZE SHOULD BE 0.93x0.93mm, 1.13mm PITCH.

Note: For the most current package drawings, please see the Microchip Packaging Specification located at <http://www.microchip.com/packaging>.

## Package Outlines and Dimensions

### TITLE

64 LEAD QFN 8x8mm PACKAGE OUTLINE & RECOMMENDED LAND PATTERN

DRAWING #	QFN88-64LD-PL-2	UNIT	MM
-----------	-----------------	------	----

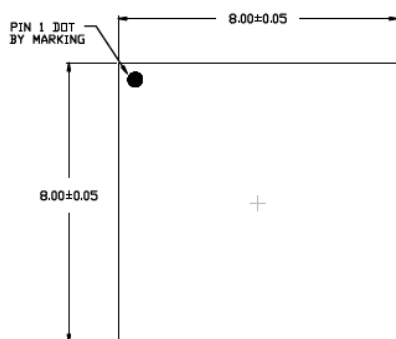

TOP VIEW  
NOTE : 1,2,3,4

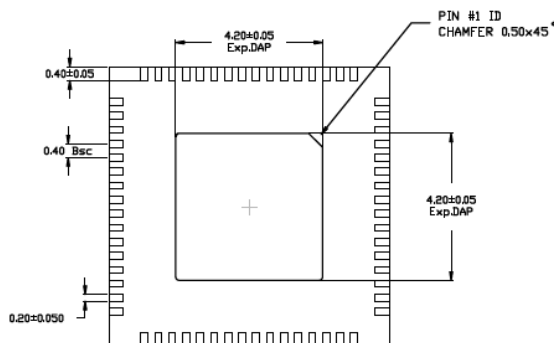

BOTTOM VIEW  
NOTE : 1,2,3,4,5

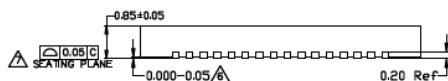

SIDE VIEW  
NOTE : 1,2,3,4,5,6,7

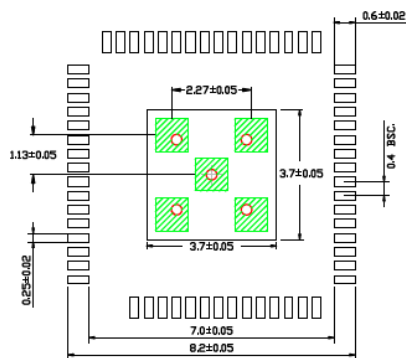

RECOMMENDED LAND PATTERN  
NOTE : 8,9

1. ALL DIMENSIONS ARE IN MILLIMETERS.
2. MAX. PACKAGE WARPAGE IS 0.05 mm.
3. MAXIMUM ALLOWABLE BURRS IS 0.076 mm IN ALL DIRECTIONS.
4. PIN #1 ID ON TOP (PACKAGE) WILL BE LASER MARKED.
- △ DIMENSION APPLIES TO METALIZED TERMINAL AND IS MEASURED BETWEEN 0.20 AND 0.25 mm FROM TERMINAL TIP.
- △ APPLIED ONLY FOR TERMINALS.
- △ APPLIED FOR EXPOSED PAD AND TERMINALS.
8. RED CIRCLE INDICATES THERMAL VIA. SIZE SHOULD BE 0.300-0.350mm IN DIAMETER AND IT SHOULD BE CONNECTED TO GND PLANE FOR MAXIMUM THERMAL PERFORMANCE.
9. GREEN RECTANGLE (WITH SHADED AREA) INDICATES SOLDER STENCIL OPENING ON EXPOSED PAD AREA. SIZE SHOULD BE 0.93x0.93mm.

Note: For the most current package drawings, please see the Microchip Packaging Specification located at <http://www.microchip.com/packaging>.

---



---

## Package Outlines and Dimensions

---



---

**TITLE**

64 LEAD QFN 9.0x9.0mm PACKAGE OUTLINE &amp; RECOMMENDED LAND PATTERN

<b>DRAWING #</b>	QFN99-64LD-PL-1	<b>UNIT</b>	MM
<b>Lead Frame Type</b>	AgCu	<b>Lead Finish</b>	Matte Tin

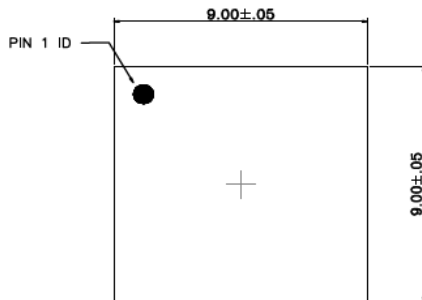

**TOP VIEW**  
NOTE: 1, 2, 3

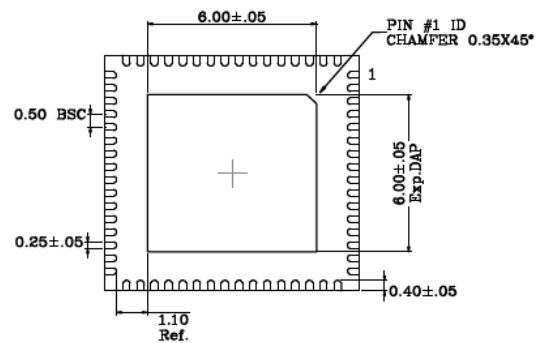

**BOTTOM VIEW**  
NOTE: 1, 2, 3



**SIDE VIEW**  
NOTE: 1, 2, 3

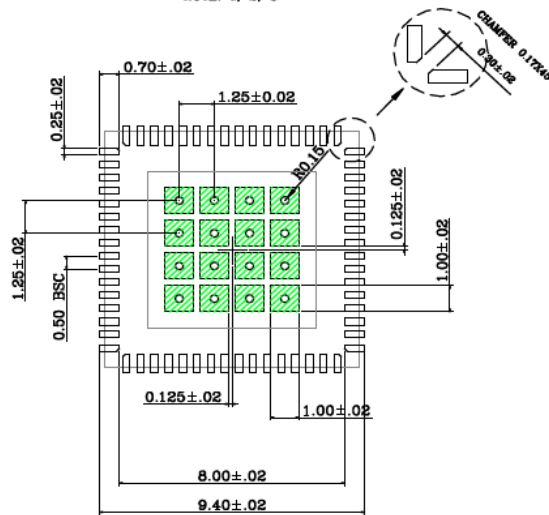

**RECOMMENDED LAND PATTERN**  
NOTE: 4, 5

**NOTE:**

1. MAX PACKAGE WARPAGE IS 0.05mm.
2. MAX ALLOWABLE BURR IS 0.076mm IN ALL DIRECTIONS.
3. PIN #1 IS ON TOP WILL BE LASER MARK.
4. RED CIRCLES IN LAND PATTERN INDICATES THERMAL VIA. SIZE SHOULD BE 0.30-0.35mm IN DIAMETER AND SHOULD BE CONNECTED TO GND FOR MAX THERMAL PERFORMANCE. PITCH IS 1.25mm.
5. GREEN RECTANGLES (SHADED AREA) REPRESENT SOLDER STENCIL OPENING ON EXPOSED PAD AREA. RECOMMENDED SIZE IS 1.0x1.0mm, SPACING IS 0.25mm.

Note: For the most current package drawings, please see the Microchip Packaging Specification located at <http://www.microchip.com/packaging>.

## Package Outlines and Dimensions

### TITLE

68 LEAD QFN 8x8mm PACKAGE OUTLINE & RECOMMENDED LAND PATTERN

DRAWING #	QFN88-68LD-PL-86	UNIT	MM
-----------	------------------	------	----

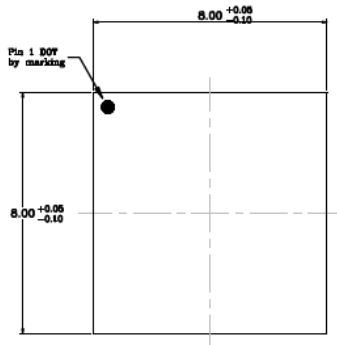

**TOP VIEW**  
NOTE : 1.3.3.4

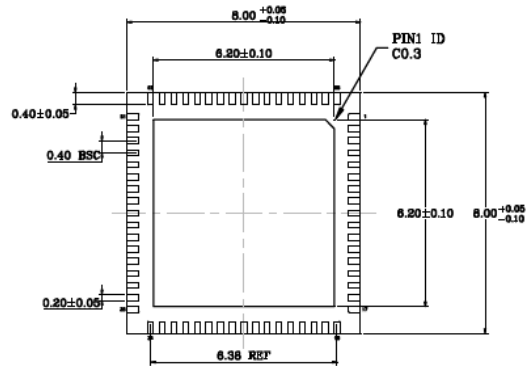

**BOTTOM VIEW**  
NOTE : 1.3.3

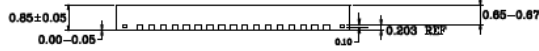

**SIDE VIEW**  
NOTE : 1.3.3

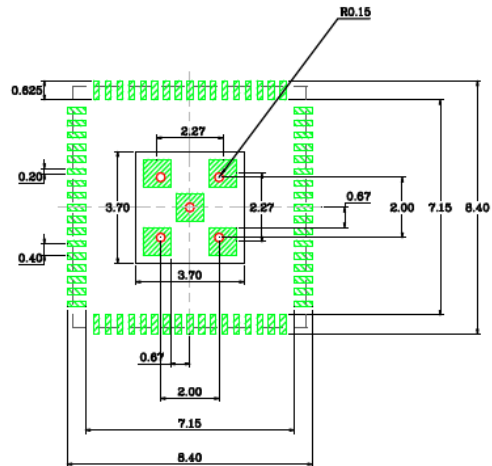

**RECOMMENDED LAND PATTERN**  
NOTE : 6.6.7

### NOTE:

1. All dimension in mm.
2. Maximum package warpage is 0.05mm.
3. Maximum allowable burr is 0.076mm in all direction.
4. Top pin #1 ID is laser marked.
5. Red circles indicates thermal via. Size should be 0.30-0.35mm in diameter and should be connected to GND plane for maximum thermal performance.
6. Green rectangles (shaded area) indicates solder stencil opening. Exposed pad solder stencil opening is 0.93mm x 0.93mm.
7. Recommended Land Pattern is  $\pm 0.02$  unless specified.

Note: For the most current package drawings, please see the Microchip Packaging Specification located at <http://www.microchip.com/package>.

---



---

## Package Outlines and Dimensions

---



---

**TITLE**

72 LEAD QFN 10x10mm PACKAGE OUTLINE &amp; RECOMMENDED LAND PATTERN

<b>DRAWING #</b>	QFN1010-72LD-PL-1	<b>UNIT</b>	MM
<b>Lead Frame Type</b>	AgCu	<b>Lead Finish</b>	Matte Tin

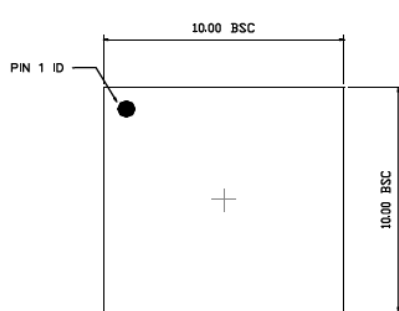

TOP VIEW  
NOTE: 1, 2, 3

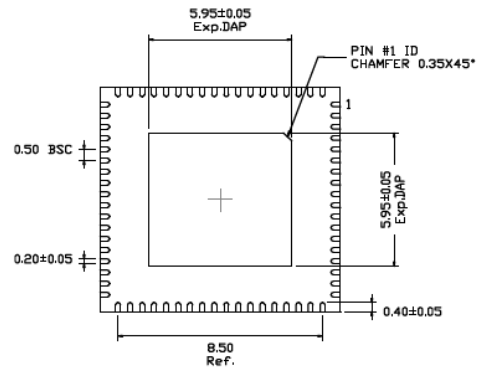

BOTTOM VIEW  
NOTE: 1, 2, 3

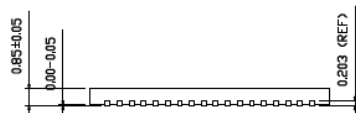

SIDE VIEW  
NOTE: 1, 2, 3

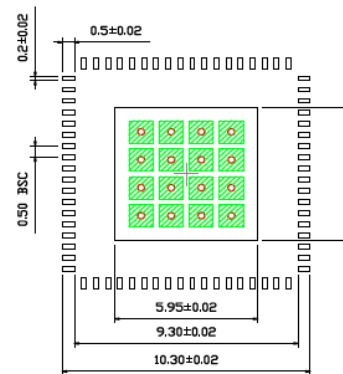

RECOMMENDED LAND PATTERN  
NOTE: 4, 5

**NOTE:**

1. MAX PACKAGE WARPAGE IS 0.05mm.
2. MAX ALLOWABLE BURR IS 0.076mm IN ALL DIRECTIONS.
3. PIN #1 IS ON TOP WILL BE LASER MARK.
4. RED CIRCLES IN LAND PATTERN INDICATES THERMAL VIA. SIZE SHOULD BE 0.30-0.3mm IN DIAMETER AND SHOULD BE CONNECTED TO GND FOR MAX THERMAL PERFORMANCE. 1.0MM PITCH
5. GREEN RECTANGLES (SHADED AREA) REPRESENT SOLDER STENCIL OPENING ON EXPOSED PAD AREA. RECOMMENDED SIZE IS 1.0x1.0mm, SPACING IS 0.25mm.

Note: For the most current package drawings, please see the Microchip Packaging Specification located at <http://www.microchip.com/packaging>.

## Package Outlines and Dimensions

### TITLE

84 LEAD QFN 7x7mm PACKAGE OUTLINE & RECOMMENDED LAND PATTERN

DRAWING #	QFN77-84LD-PL-1	UNIT	MM
Lead Frame	Substrate	Lead Finish	Matte Tin

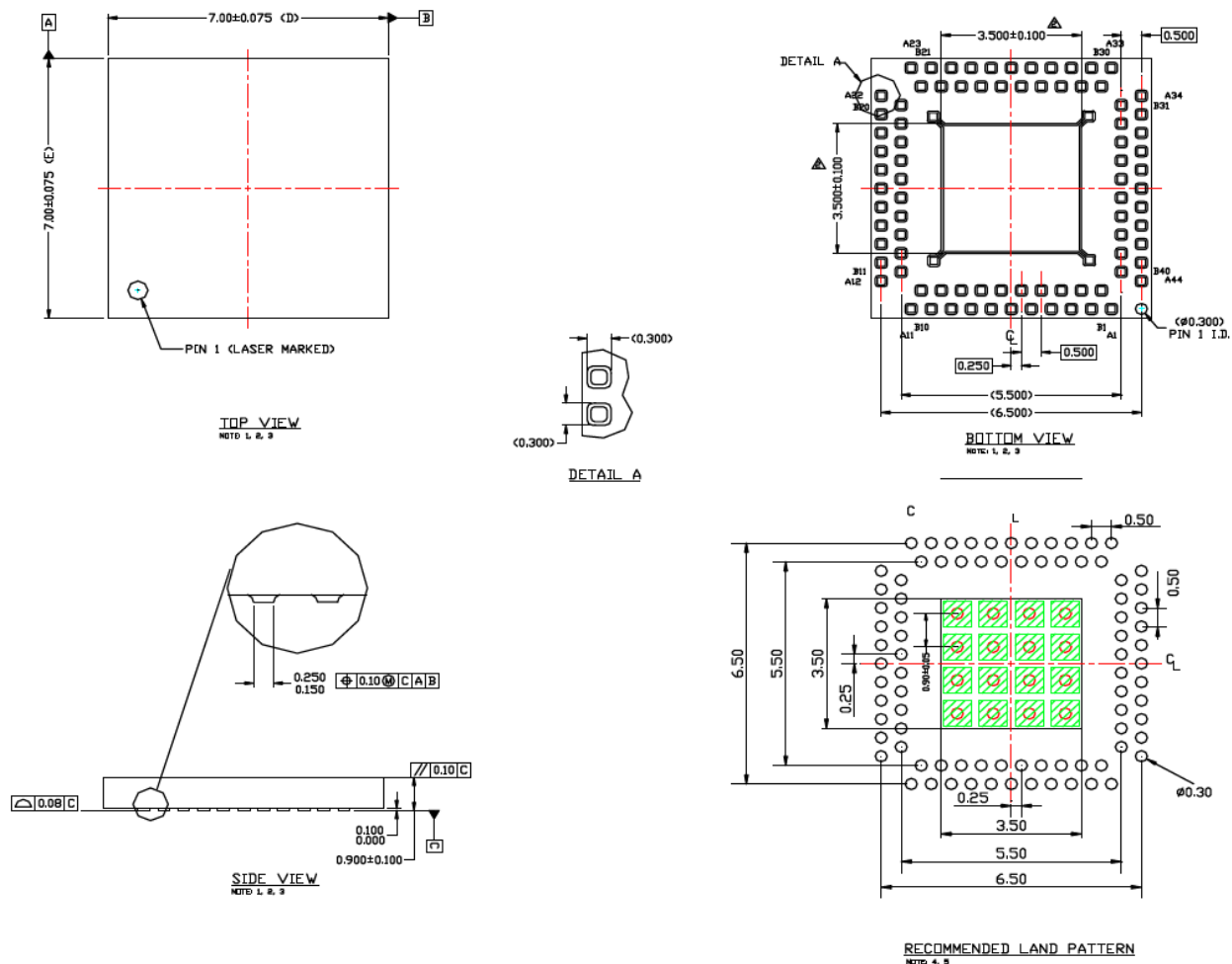

### NOTE:

1. MAX PACKAGE WARPAGE IS 0.05mm.
2. MAX ALLOWABLE BURR IS 0.076mm IN ALL DIRECTIONS.
3. PIN #1 IS ON TOP WILL BE LASER MARKED.
4. RED CIRCLE IN LAND PATTERN INDICATES THERMAL VIA. SIZE SHOULD BE 0.30-0.35mm IN DIAMETER AND SHOULD BE CONNECTED TO GND FOR MAXIMUM THERMAL PERFORMANCE. PITCH IS 0.90mm.
5. GREEN RECTANGLES (SHADED AREA) REPRESENT SOLDER STENCIL OPENING ON EXPOSED PAD AREA. RECOMMENDED SIZE IS 0.70x0.70 mm, PITCH IS 0.90 mm.

Note: For the most current package drawings, please see the Microchip Packaging Specification located at <http://www.microchip.com/packaging>.



---

---

**Package Outlines and Dimensions**

---

---

**QSOP**

Micrel Legacy

## Package Outlines and Dimensions

### TITLE

16 LEAD Q SOP PACKAGE OUTLINE & RECOMMENDED LAND PATTERN

DRAWING #	QSOP-16LD-PL-1	UNIT	INCH
Lead Frame	Copper	Lead Finish	Matte Tin

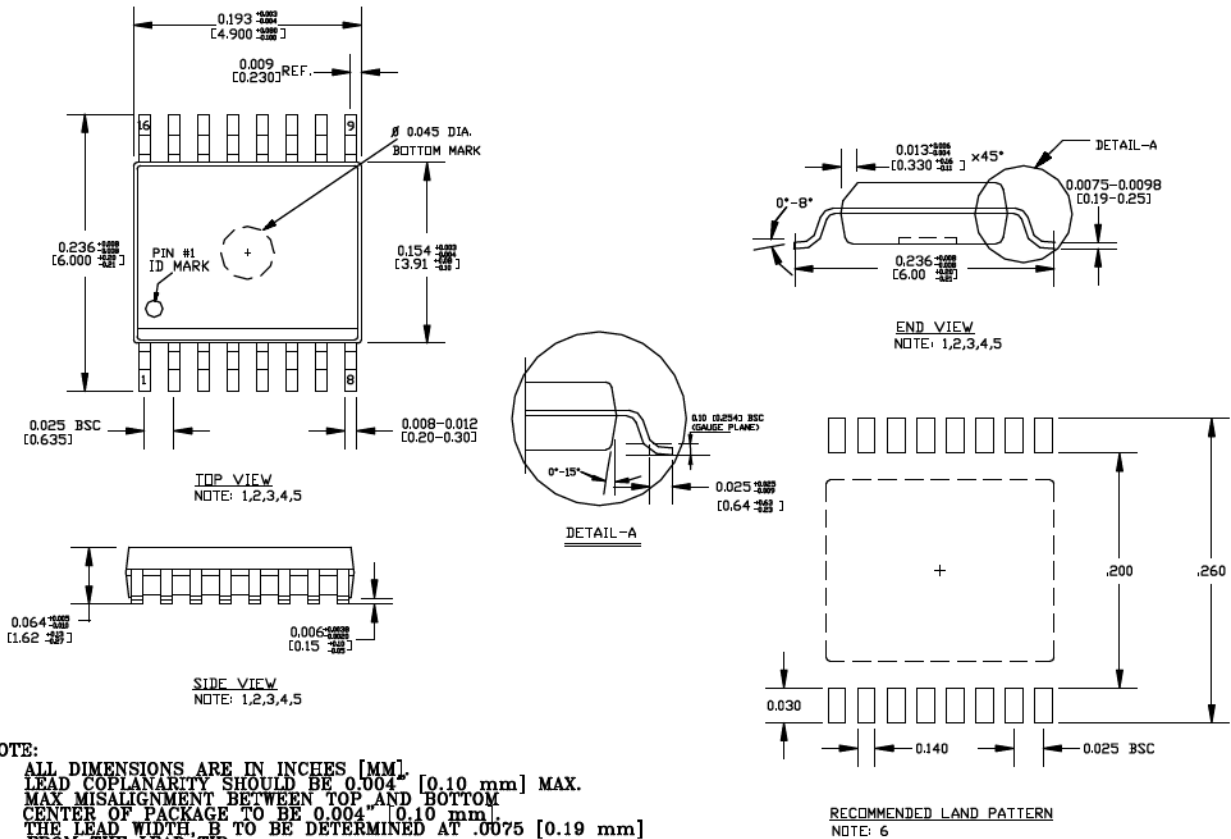

#### NOTE:

- ALL DIMENSIONS ARE IN INCHES [MM].
- LEAD COPLANARITY SHOULD BE 0.004" [0.10 mm] MAX.
- MAX MISALIGNMENT BETWEEN TOP AND BOTTOM CENTER OF PACKAGE TO BE 0.004" [0.10 mm].
- THE LEAD WIDTH, B TO BE DETERMINED AT .0075 [0.19 mm] FROM THE LEAD TIP.
- BOTTOM MARK IS OPTIONAL, IT MAY NOT APPEAR ON THE ACTUAL UNITS.
- LAND PATTERN IS IN INCH. TOLERANCE IS +/- 0.002.

Note: For the most current package drawings, please see the Microchip Packaging Specification located at <http://www.microchip.com/packaging>.

## Package Outlines and Dimensions

**TITLE**

16 LEAD QSOP EPAD PACKAGE OUTLINE & RECOMMENDED LAND PATTERN

DRAWING #	QSOPEP-16LD-PL-1	UNIT	INCH [MM]
-----------	------------------	------	-----------

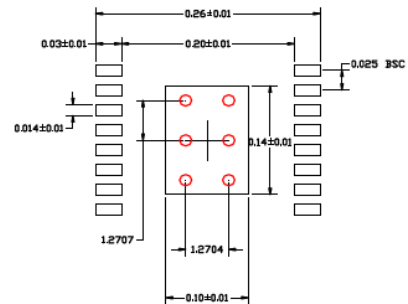
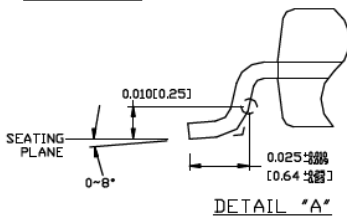
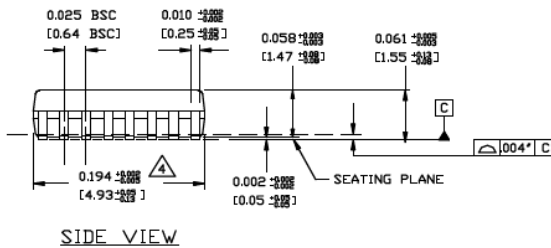
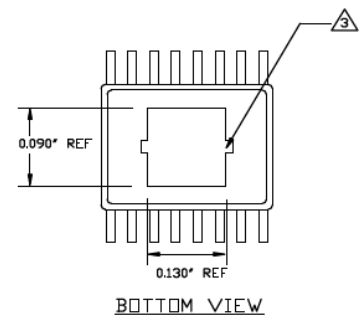
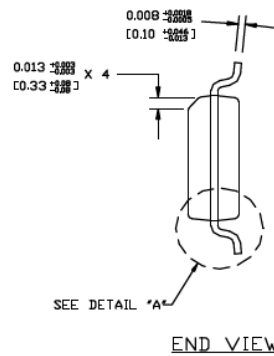
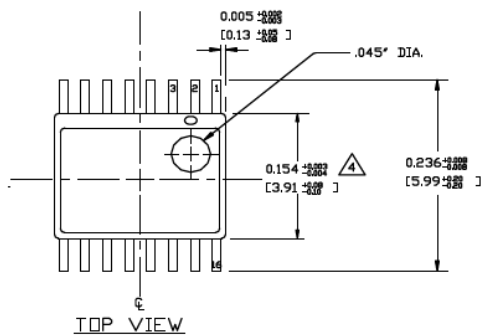

**NOTE:**

- EXPOSED PAD ON BOTTOM SIDE IS THE SAME AS LEAD FRAME PADDLE SIZE
- RED CIRCLES IN LAND PATTERN REPRESENT THERMAL VIAS. RECOMMENDED SIZE IS 0.30-0.35MM IN DIAMETER, 1.00 PITCH AND SHOULD BE CONNECTED TO GND FOR MAXIMUM PERFORMANCE
- EXTRUSION OF EXPOSED PAD ON BOTTOM SIDE IS 0.20MM TYP.
- DIMENSION DOES NOT INCLUDE MOLD FLASH OR PROTRUSIONS, EITHER OF WHICH SHALL EXCEED 0.006 INCHES FOR ENDS AND 0.008 INCHES FOR SIDES

Note: For the most current package drawings, please see the Microchip Packaging Specification located at <http://www.microchip.com/packaging>.

## Package Outlines and Dimensions

### TITLE

20 LEAD QSOP PACKAGE OUTLINE & RECOMMENDED LAND PATTERN

<b>DRAWING #</b>	QSOP-20LD-PL-1	<b>UNIT</b>	INCH
<b>Lead Frame</b>	Copper	<b>Lead Finish</b>	Matte Tin

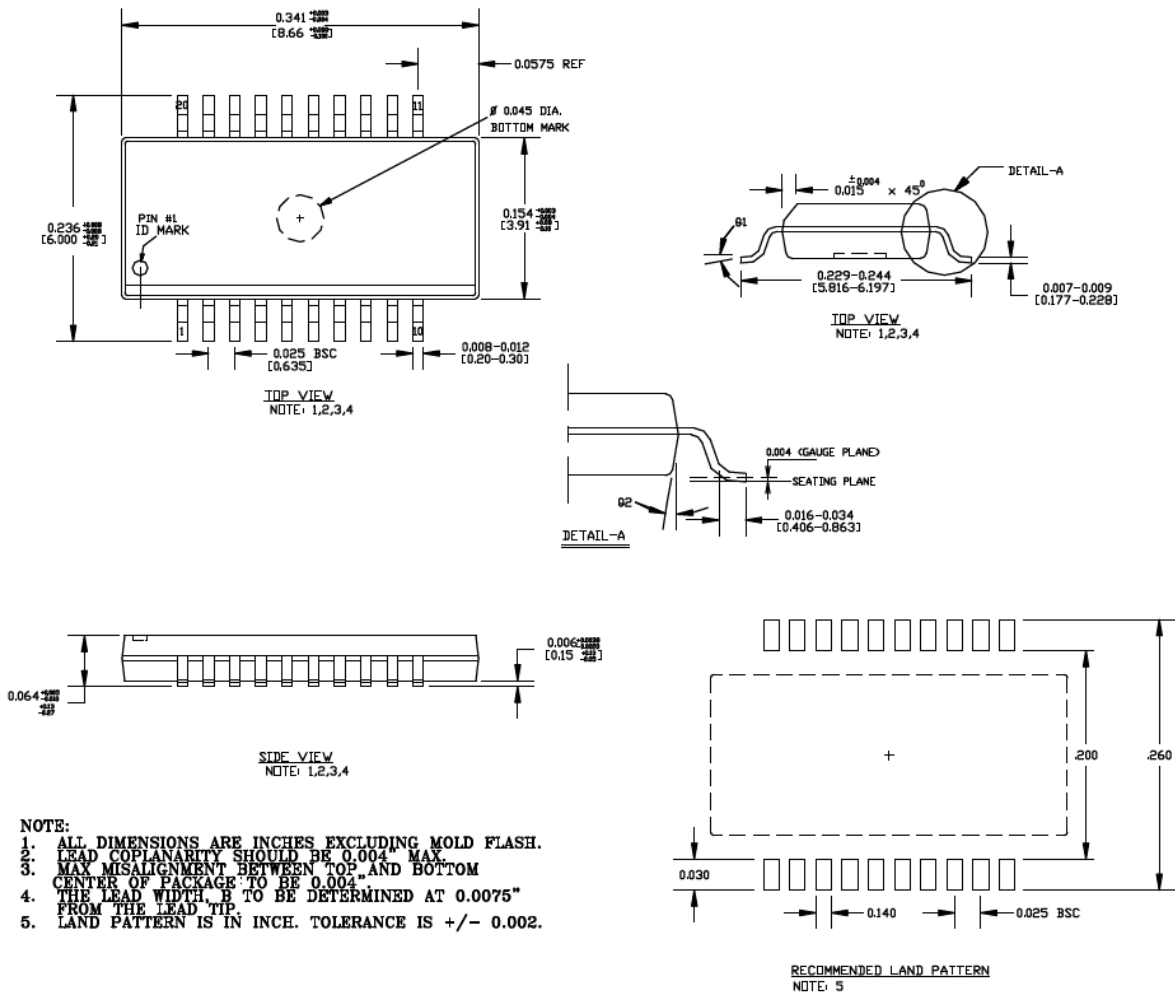

Note: For the most current package drawings, please see the Microchip Packaging Specification located at <http://www.microchip.com/packaging>.

---

---

**Package Outlines and Dimensions**

---

---

**SC70**

Micrel Legacy

**Package Outlines and Dimensions**

**TITLE**

3 LEAD SC70 PACKAGE OUTLINE & RECOMMENDED LAND PATTERN

<b>DRAWING #</b>	SC70-3LD-PL-1	<b>UNIT</b>	MM
<b>Lead Frame</b>	Copper	<b>Lead Finish</b>	Matte Tin

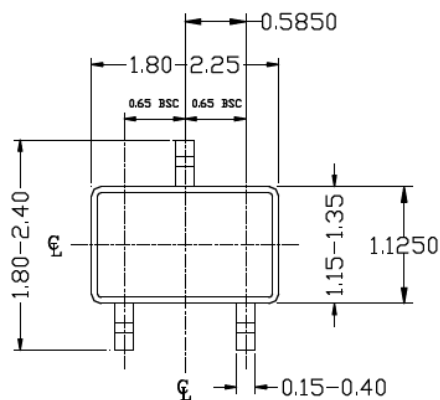

TOP VIEW

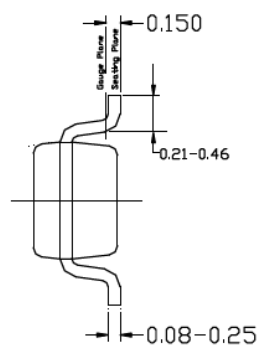

END VIEW

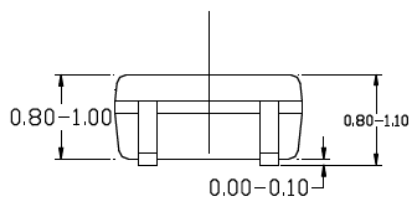

SIDE VIEW

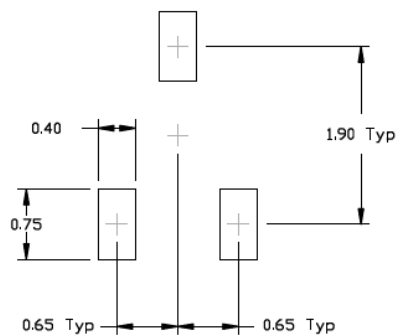

RECOMMENDED LAND PATTERN

- NOTE:  
 1. ALL DIMENSIONS ARE IN MILLIMETERS.  
 2. DIMENSIONS ARE INCLUSIVE OF PLATING.  
 3. DIMENSIONS ARE EXCLUSIVE OF MOLD FLASH & METAL BURR.

Note: For the most current package drawings, please see the Microchip Packaging Specification located at <http://www.microchip.com/package>.

**Package Outlines and Dimensions**

**TITLE**

4 LEAD SC70 PACKAGE OUTLINE & RECOMMENDED LAND PATTERN

<b>DRAWING #</b>	SC70-4LD-PL-1	<b>UNIT</b>	MM
------------------	---------------	-------------	----

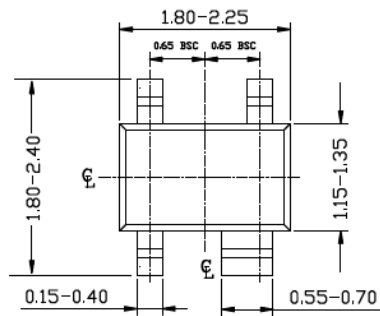

TOP VIEW

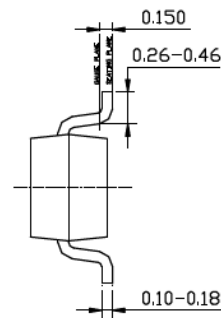

END VIEW

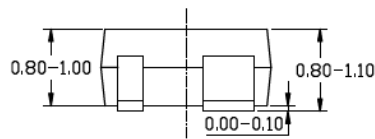

SIDE VIEW

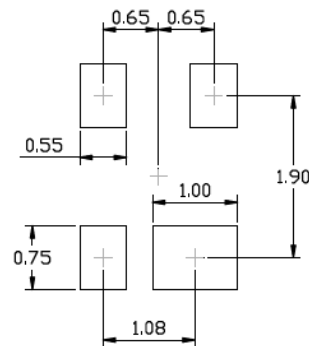

RECOMMENDED LAND PATTERN

- NOTE:
1. ALL DIMENSIONS ARE IN MILLIMETERS.
  2. DIMENSIONS ARE INCLUSIVE OF PLATING.
  3. DIMENSIONS ARE EXCLUSIVE OF MOLD FLASH & METAL BURR.

Note: For the most current package drawings, please see the Microchip Packaging Specification located at <http://www.microchip.com/packaging>.

**Package Outlines and Dimensions**

**TITLE**

5 LEAD SC70 PACKAGE OUTLINE & RECOMMENDED LAND PATTERN

<b>DRAWING #</b>	SC70-5LD-PL-1	<b>UNIT</b>	MM
------------------	---------------	-------------	----

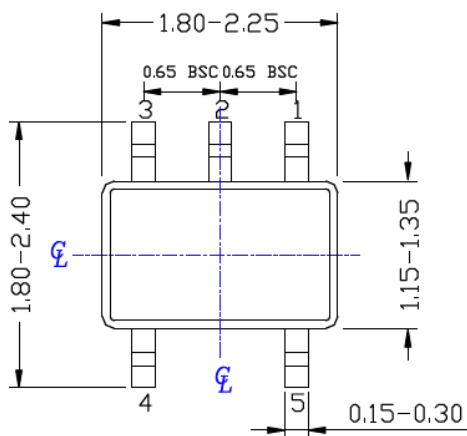

TOP VIEW

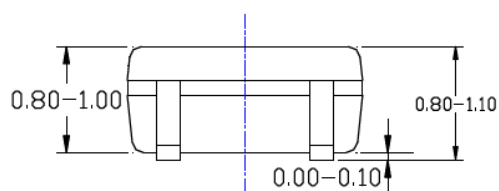

SIDE VIEW

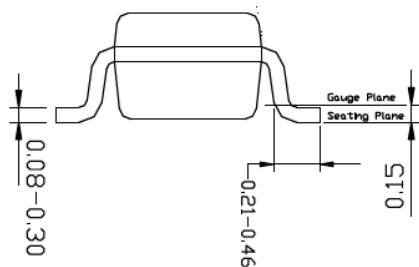

END VIEW

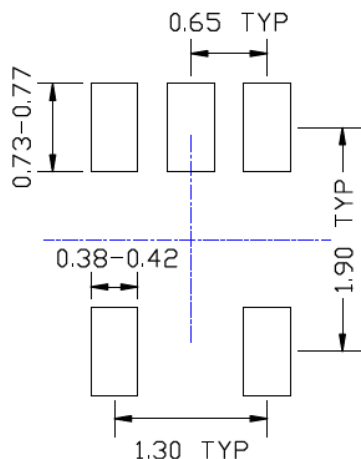

RECOMMENDED LAND PATTERN

**NOTE:**

1. ALL DIMENSIONS ARE IN MILLIMETERS.
2. DIMENSIONS ARE INCLUSIVE OF PLATING.
3. DIMENSIONS ARE EXCLUSIVE OF MOLD FLASH & METAL BURR.

Note: For the most current package drawings, please see the Microchip Packaging Specification located at <http://www.microchip.com/packageing>.



---



---

## Package Outlines and Dimensions

---



---

**TITLE**

5 LEAD SC70 PACKAGE OUTLINE &amp; RECOMMENDED LAND PATTERN

<b>DRAWING #</b>	SC70-5LD-PL-2	<b>UNIT</b>	MM
------------------	---------------	-------------	----

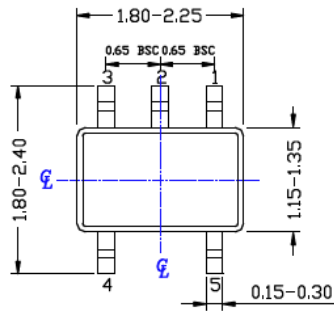
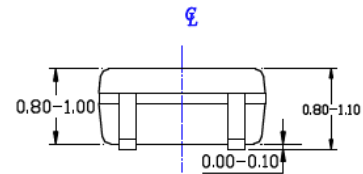
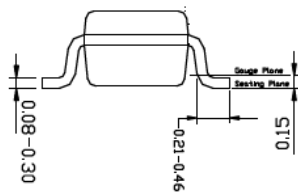
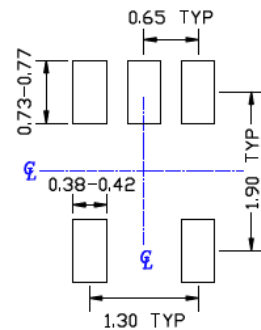
**TOP VIEW**

**SIDE VIEW**

**END VIEW**

**RECOMMENDED LAND PATTERN**
**NOTE:**

1. ALL DIMENSIONS ARE IN MILLIMETERS.
2. DIMENSIONS ARE INCLUSIVE OF PLATING.
3. DIMENSIONS ARE EXCLUSIVE OF MOLD FLASH & METAL BURR.

Note: For the most current package drawings, please see the Microchip Packaging Specification located at <http://www.microchip.com/packaging>.

**Package Outlines and Dimensions**

**TITLE**

6 LEAD SC70 PACKAGE OUTLINE & RECOMMENDED LAND PATTERN

DRAWING #	SC70-6LD-PL-1	UNIT	MM
-----------	---------------	------	----

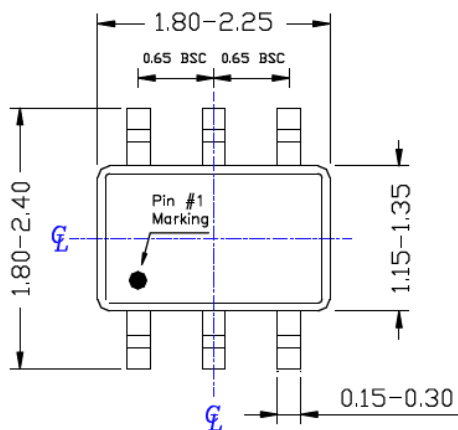

TOP VIEW

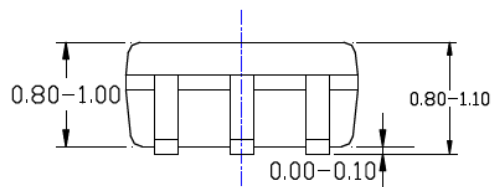

SIDE VIEW

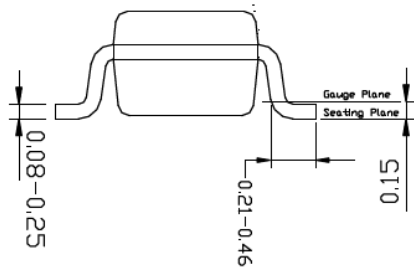

END VIEW

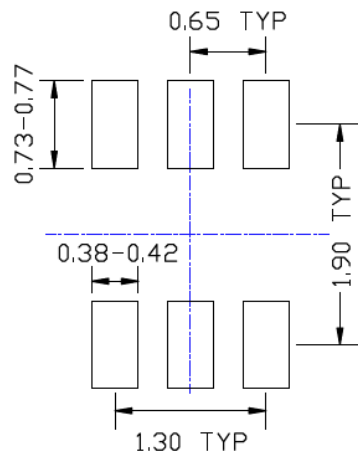

RECOMMENDED LAND PATTERN

**NOTE:**

1. ALL DIMENSIONS ARE IN MILLIMETERS.
2. DIMENSIONS ARE INCLUSIVE OF PLATING.
3. DIMENSIONS ARE EXCLUSIVE OF MOLD FLASH & METAL BURR.

Note: For the most current package drawings, please see the Microchip Packaging Specification located at <http://www.microchip.com/packaging>.

---

---

**Package Outlines and Dimensions**

---

---

**SOIC**

Micrel Legacy

## Package Outlines and Dimensions

### TITLE

8 LEAD SOICN PACKAGE OUTLINE & RECOMMENDED LAND PATTERN

DRAWING #	SOICN-8LD-PL-1	UNIT	INCH [MM]
-----------	----------------	------	-----------

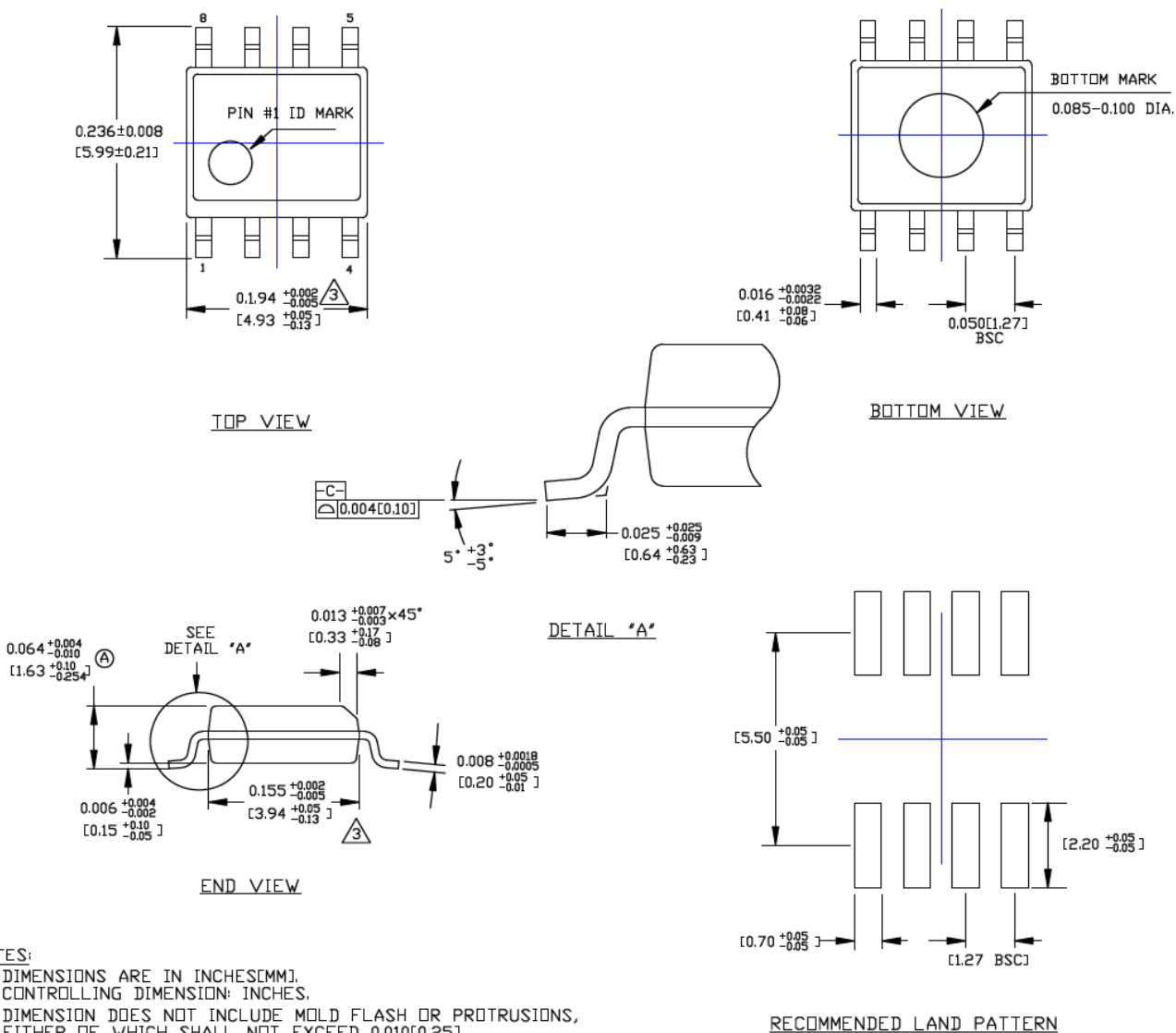

Note: For the most current package drawings, please see the Microchip Packaging Specification located at <http://www.microchip.com/packaging>.

**Package Outlines and Dimensions**

**TITLE**

8 LEAD SOICN EPAD PACKAGE OUTLINE & RECOMMENDED LAND PATTERN

DRAWING #	SOICNEP-8LD-PL-1	UNIT	INCH [MM]
-----------	------------------	------	-----------

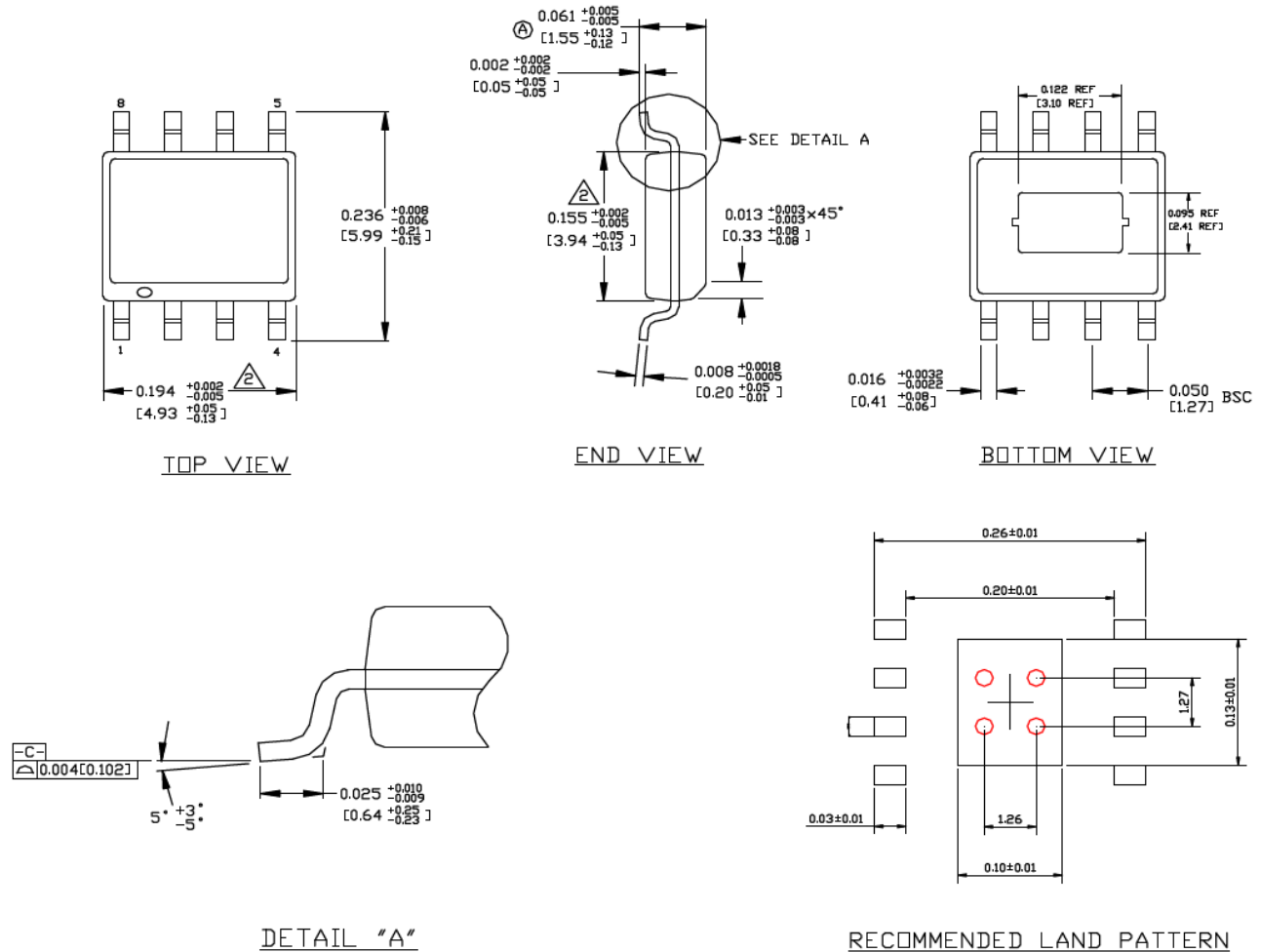

**NOTE:**

1. DIMENSION DOES NOT INCLUDE MOLD FLASH OR PROTRUSIONS, EITHER OF WHICH SHALL EXCEED 0.006 INCHES PER SIDE

△ RED CIRCLES IN LAND PATTERN REPRESENT THERMAL VIAS. RECOMMENDED SIZE IS 0.30-0.30MM IN DIAMETER AND SHOULD BE CONNECTED TO GND FOR MAXIMUM THERMAL PERFORMANCE

Note: For the most current package drawings, please see the Microchip Packaging Specification located at <http://www.microchip.com/packaging>.

## Package Outlines and Dimensions

### TITLE

14 LEAD SOICN PACKAGE OUTLINE & RECOMMENDED LAND PATTERN

<b>DRAWING #</b>	SOICN-14LD-PL-1	<b>UNIT</b>	INCH [MM]
<b>Lead Frame</b>	Copper	<b>Lead Finish</b>	Matte Tin

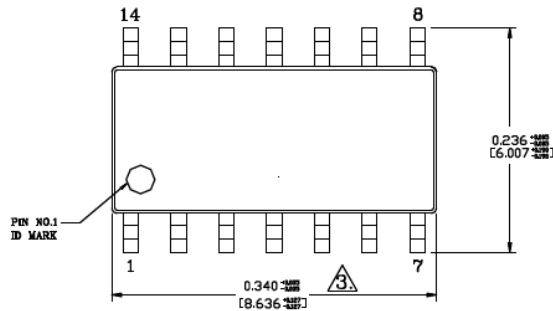

**TOP VIEW**

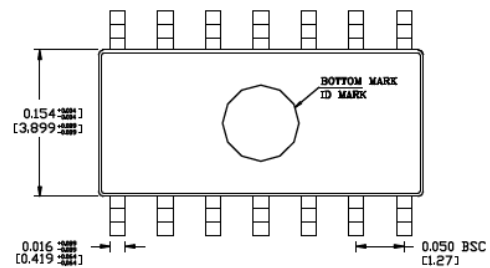

**BOTTOM VIEW**

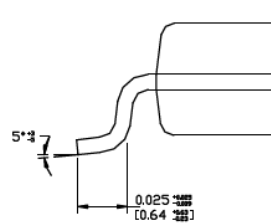

**DETAIL "A"**

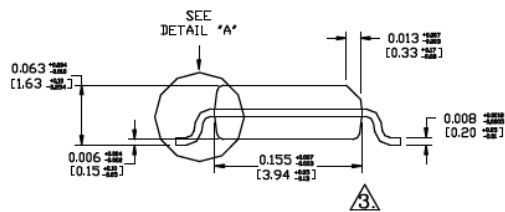

**END VIEW**

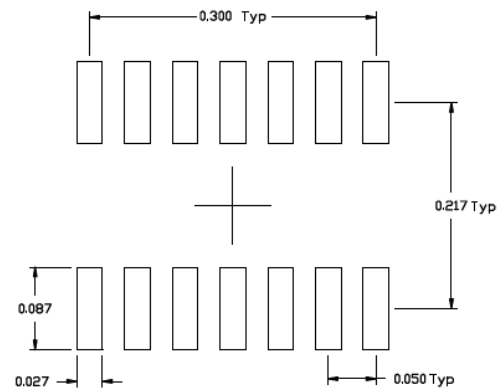

**RECOMMENDED LAND PATTERN**

### NOTES:

1. DIMENSIONS ARE IN INCHES [MILLIMETER].
2. CONTROLLING DIMENSION: INCHES.
3. DIMENSION DOES NOT INCLUDE MOLD FLASH OR PROTRUSIONS, EITHER OF WHICH SHALL NOT EXCEED 0.010 [0.25] PER SIDE.

Note: For the most current package drawings, please see the Microchip Packaging Specification located at <http://www.microchip.com/packaging>.

## Package Outlines and Dimensions

**TITLE**

16 LEAD SOICN PACKAGE OUTLINE & RECOMMENDED LAND PATTERN

<b>DRAWING #</b>	SOICN-16LD-PL-1	<b>UNIT</b>	INCH [MM]
<b>Lead Frame</b>	Copper	<b>Lead Finish</b>	Matte Tin

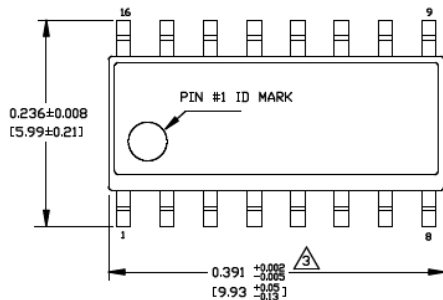

TOP VIEW

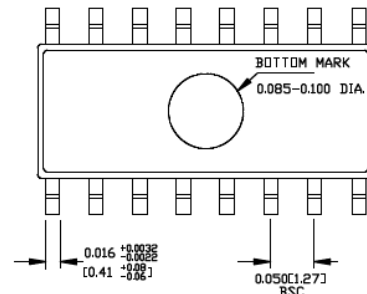

BOTTOM VIEW

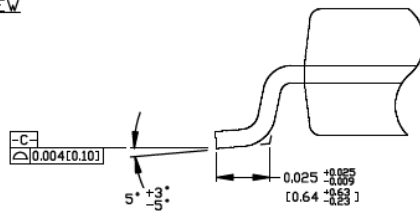

DETAIL "A"

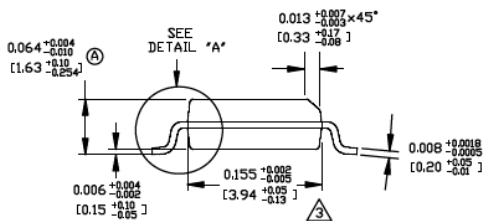

END VIEW

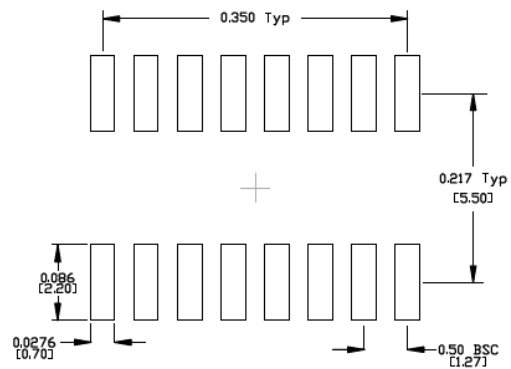

RECOMMENDED LAND PATTERN

**NOTES:**

1. DIMENSIONS ARE IN INCHES[MM].
2. CONTROLLING DIMENSION: INCHES.
3. DIMENSION DOES NOT INCLUDE MOLD FLASH OR PROTRUSIONS, EITHER OF WHICH SHALL NOT EXCEED 0.010[0.25] PER SIDE.

Note: For the most current package drawings, please see the Microchip Packaging Specification located at <http://www.microchip.com/packaging>.

## Package Outlines and Dimensions

### TITLE

16 LEAD SOICW PACKAGE OUTLINE & RECOMMENDED LAND PATTERN

DRAWING #	SOICW-16LD-PL-1	UNIT	INCH [MM]
-----------	-----------------	------	-----------

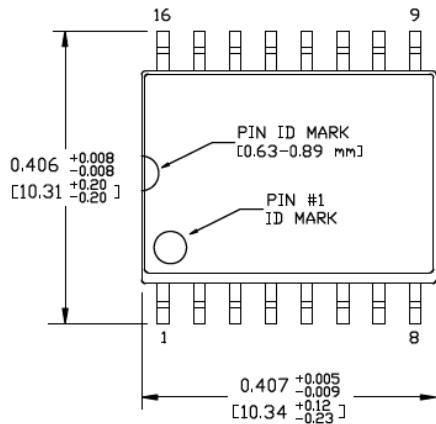

TOP VIEW  
NOTE 1, 2

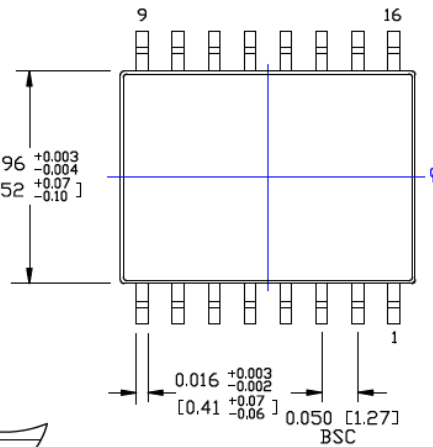

BOTTOM VIEW  
NOTE 1, 2

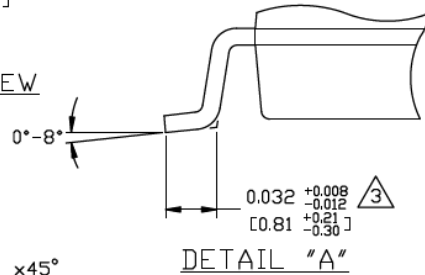

DETAIL "A"

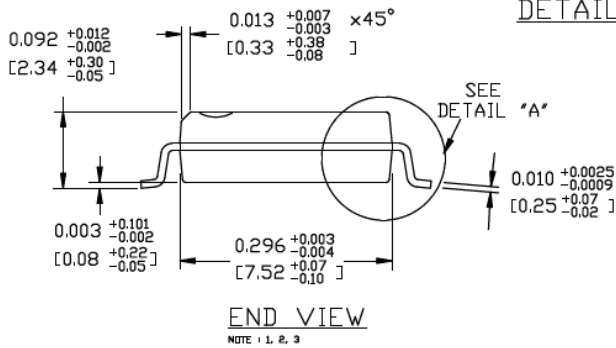

END VIEW  
NOTE 1, 2, 3

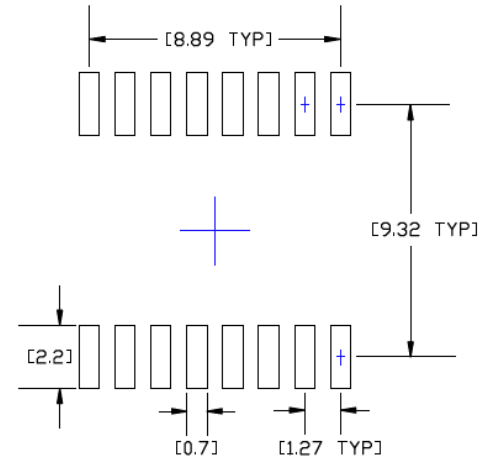

RECOMMENDED LAND PATTERN

### NOTES:

1. DIMENSIONS ARE IN INCHES[MM].
2. CONTROLLING DIMENSION: INCHES.
3. DIMENSION DOES NOT INCLUDE MOLD FLASH OR PROTRUSIONS, EITHER OF WHICH SHALL NOT EXCEED 0.006[0.15] PER SIDE.

Note: For the most current package drawings, please see the Microchip Packaging Specification located at <http://www.microchip.com/packaging>.



## Package Outlines and Dimensions

**TITLE**

18 LEAD SOICW PACKAGE OUTLINE &amp; RECOMMENDED LAND PATTERN

DRAWING #	SOICW-18LD-PL-1	UNIT	INCH [MM]
-----------	-----------------	------	-----------

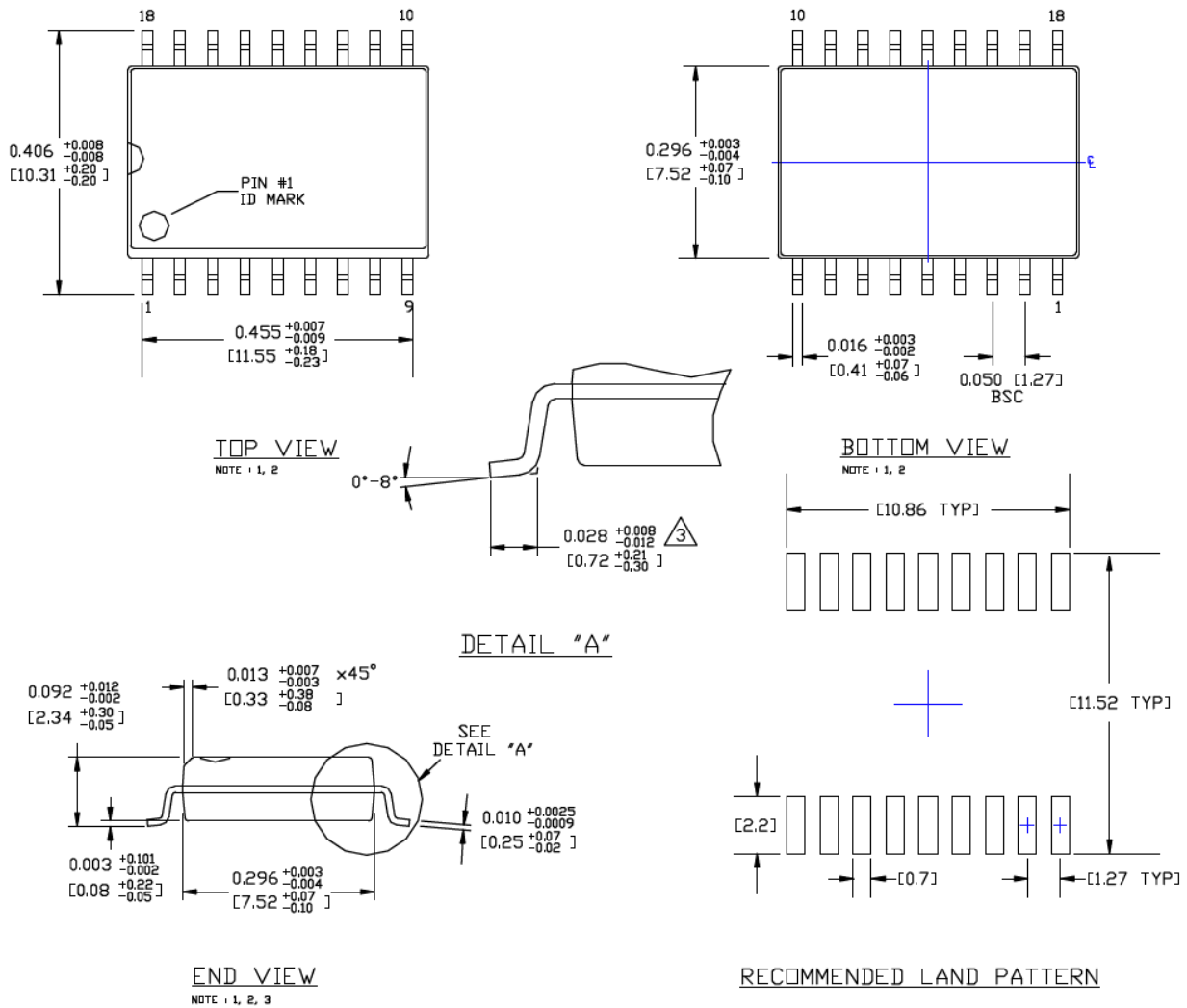
**NOTES:**

1. DIMENSIONS ARE IN INCHES[MM].
2. CONTROLLING DIMENSION: INCHES.
3. DIMENSION DOES NOT INCLUDE MOLD FLASH OR PROTRUSIONS, EITHER OF WHICH SHALL NOT EXCEED 0.006[0.15] PER SIDE.

Note: For the most current package drawings, please see the Microchip Packaging Specification located at <http://www.microchip.com/packaging>.

## Package Outlines and Dimensions

### TITLE

20 LEAD SOICW PACKAGE OUTLINE & RECOMMENDED LAND PATTERN

DRAWING #	SOICW-20LD-PL-1	UNIT	INCH [MM]
-----------	-----------------	------	-----------

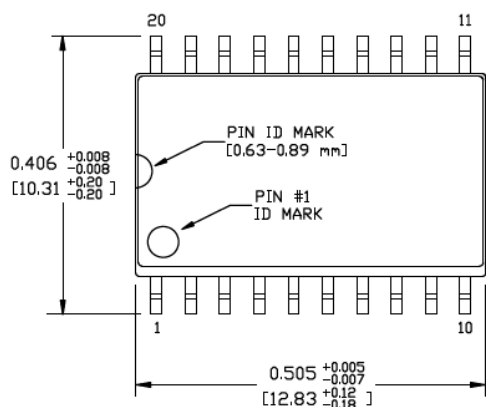

TOP VIEW  
NOTE 1, 2

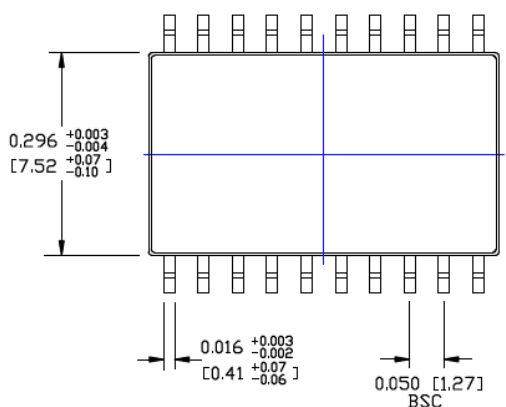

BOTTOM VIEW  
NOTE 1, 2

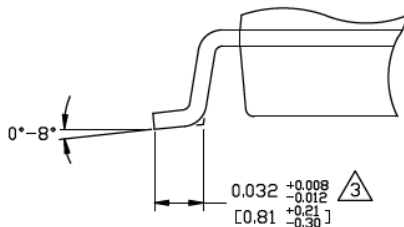

DETAIL "A"

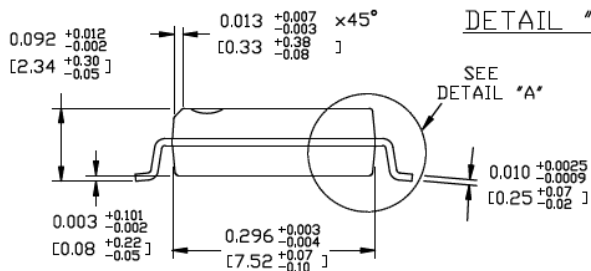

END VIEW  
NOTE 1, 2, 3

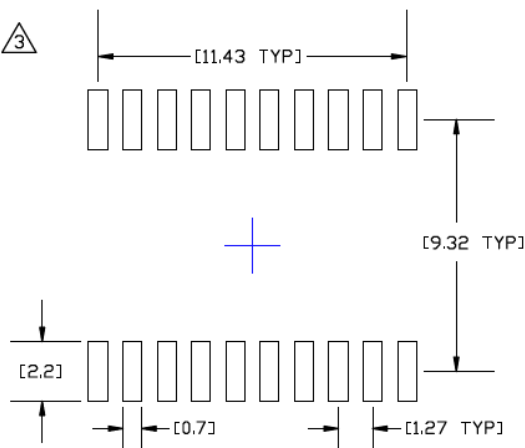

RECOMMENDED LAND PATTERN

### NOTES:

1. DIMENSIONS ARE IN INCHES[MM].
2. CONTROLLING DIMENSION: INCHES.
3. DIMENSION DOES NOT INCLUDE MOLD FLASH OR PROTRUSIONS, EITHER OF WHICH SHALL NOT EXCEED 0.006[0.15] PER SIDE.

Note: For the most current package drawings, please see the Microchip Packaging Specification located at <http://www.microchip.com/packaging>.

**Package Outlines and Dimensions**

**TITLE**

24 LEAD SOICW PACKAGE OUTLINE & RECOMMENDED LAND PATTERN

DRAWING #	SOICW-24LD-PL-1	UNIT	INCH [MM]
-----------	-----------------	------	-----------

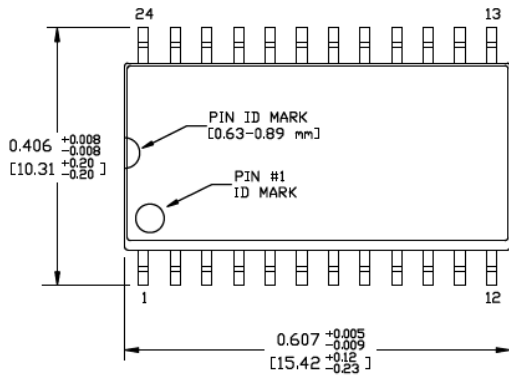

**TOP VIEW**  
NOTE 1, 2

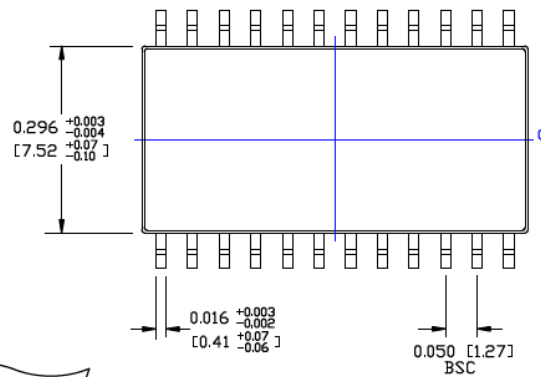

**BOTTOM VIEW**  
NOTE 1, 2

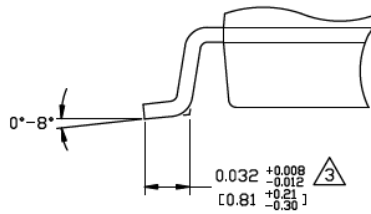

**DETAIL "A"**

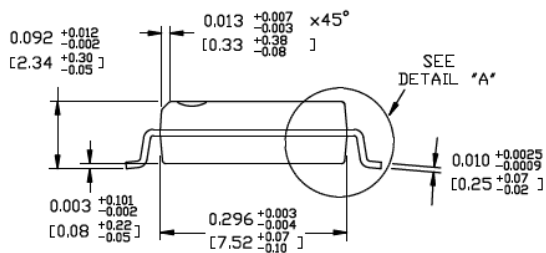

**END VIEW**  
NOTE 1, 2, 3

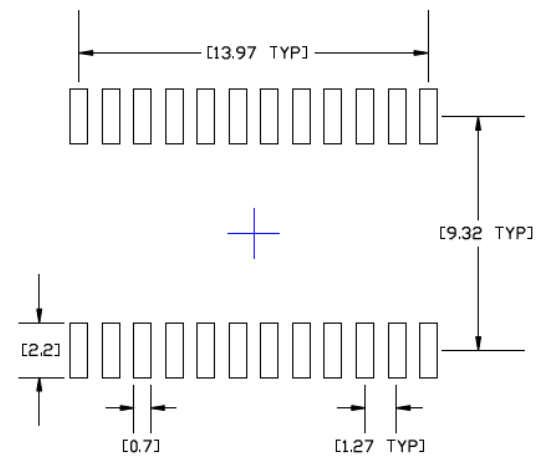

**RECOMMENDED LAND PATTERN**

**NOTES:**

1. DIMENSIONS ARE IN INCHES[MM].
2. CONTROLLING DIMENSION: INCHES.
3. DIMENSION DOES NOT INCLUDE MOLD FLASH OR PROTRUSIONS, EITHER OF WHICH SHALL NOT EXCEED 0.006[0.15] PER SIDE.

Note: For the most current package drawings, please see the Microchip Packaging Specification located at <http://www.microchip.com/packaging>.

## Package Outlines and Dimensions

### TITLE

28 LEAD SOICW PACKAGE OUTLINE & RECOMMENDED LAND PATTERN

DRAWING #	SOICW-28LD-PL-1	UNIT	INCH [MM]
-----------	-----------------	------	-----------

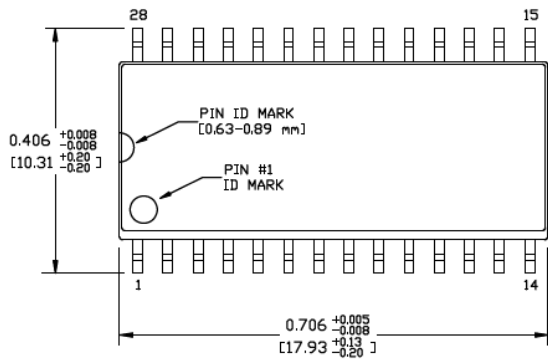

TOP VIEW

NOTE 1, 2

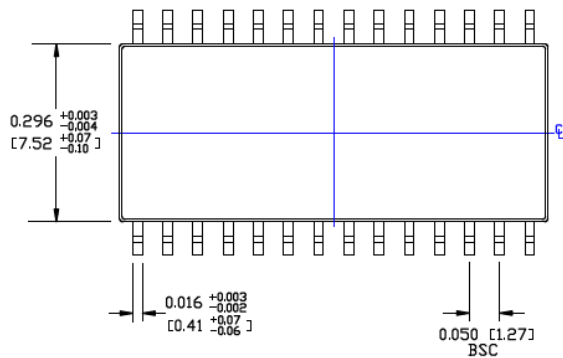

BOTTOM VIEW

NOTE 1, 2

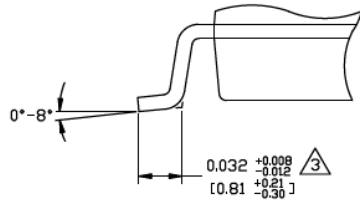

DETAIL "A"

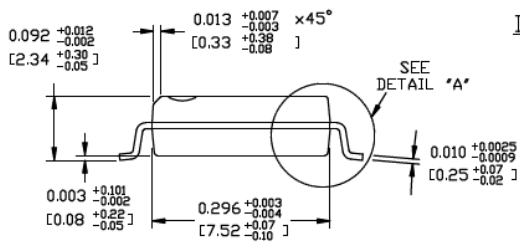

END VIEW

NOTE 1, 2, 3

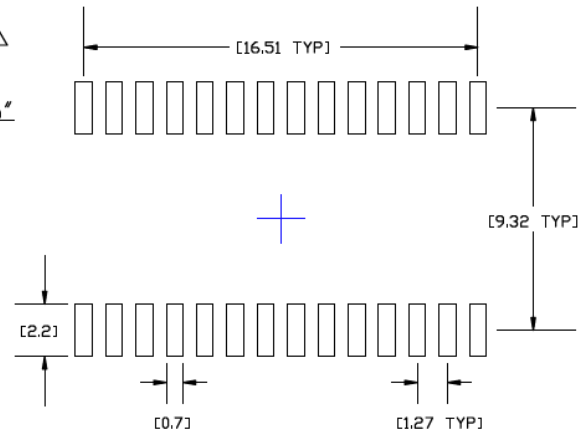

RECOMMENDED LAND PATTERN

### NOTES:

1. DIMENSIONS ARE IN INCHES[MM].
2. CONTROLLING DIMENSION: INCHES.
3. DIMENSION DOES NOT INCLUDE MOLD FLASH OR PROTRUSIONS, EITHER OF WHICH SHALL NOT EXCEED 0.006[0.15] PER SIDE.

Note: For the most current package drawings, please see the Microchip Packaging Specification located at <http://www.microchip.com/packaging>.

**Package Outlines and Dimensions**

**TITLE**

28 LEAD SOICW EPAD (0.300" BODY) PACKAGE OUTLINE & RECOMMENDED LAND PATTERN

DRAWING #	SOICWEP-28LD-PL-1	UNIT	INCH [MM]
-----------	-------------------	------	-----------

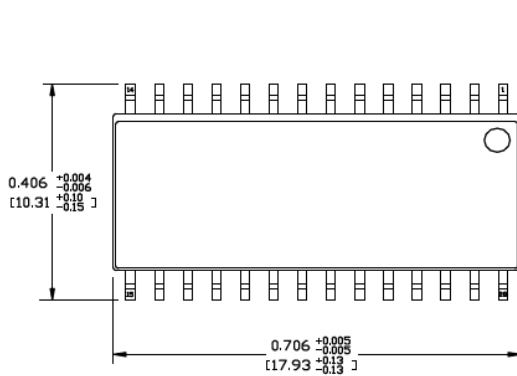

TOP VIEW

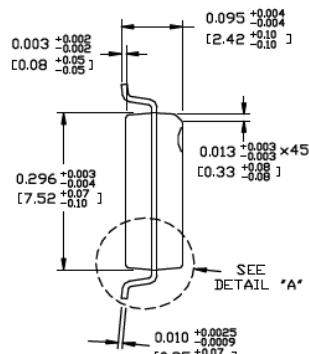

END VIEW

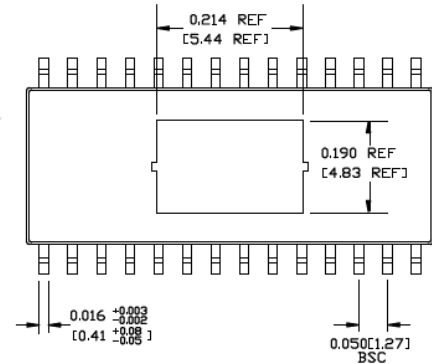

BOTTOM VIEW

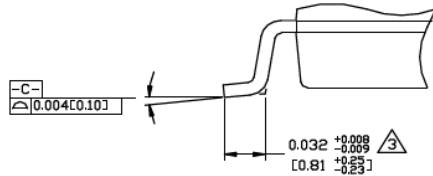

DETAIL "A"

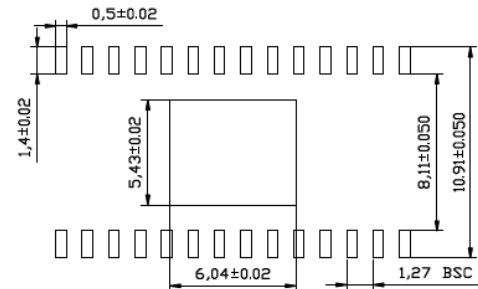

RECOMMENDED LAND PATTERN

**NOTES:**

1. DIMENSIONS ARE IN INCHES[MM].
2. CONTROLLING DIMENSION: INCHES.
3. DIMENSION DOES NOT INCLUDE MOLD FLASH OR PROTRUSIONS, EITHER OF WHICH SHALL NOT EXCEED 0.006[0.15] PER SIDE.

Note: For the most current package drawings, please see the Microchip Packaging Specification located at <http://www.microchip.com/packaging>.



**MICROCHIP**

---

---

**Package Outlines and Dimensions**

---

---

NOTES:

---

---

**Package Outlines and Dimensions**

---

---

**SOT**

Micrel Legacy

## Package Outlines and Dimensions

### TITLE

3 LEAD SOT23 PACKAGE OUTLINE & RECOMMENDED LAND PATTERN

DRAWING #	SOT23-3LD-PL-1	UNIT	MM
-----------	----------------	------	----

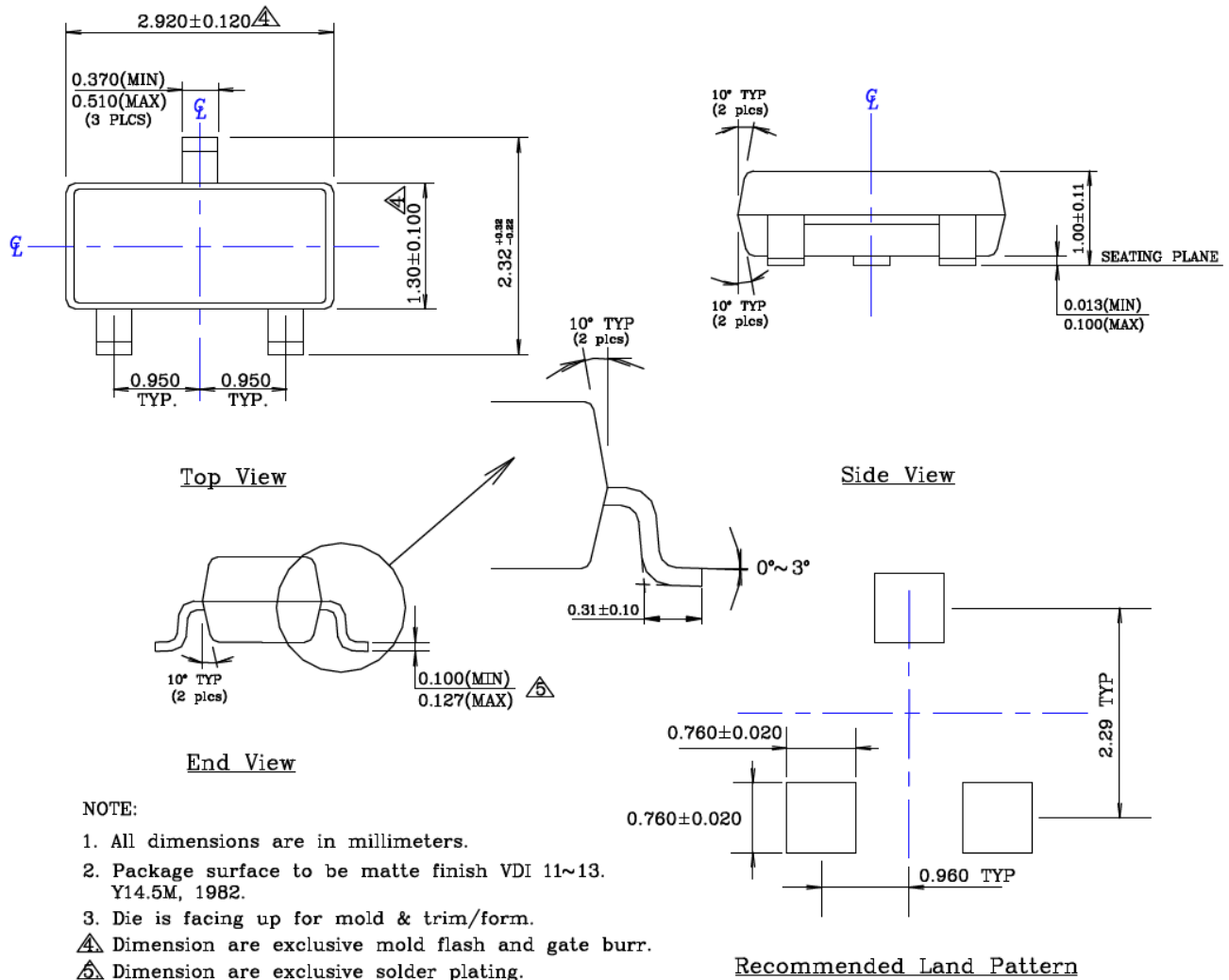

Note: For the most current package drawings, please see the Microchip Packaging Specification located at <http://www.microchip.com/packaging>.



---



---

## Package Outlines and Dimensions

---



---

**TITLE**

5 LEAD SOT23 PACKAGE OUTLINE &amp; RECOMMENDED LAND PATTERN

DRAWING #	SOT23-5LD-PL-1	UNIT	MM
-----------	----------------	------	----

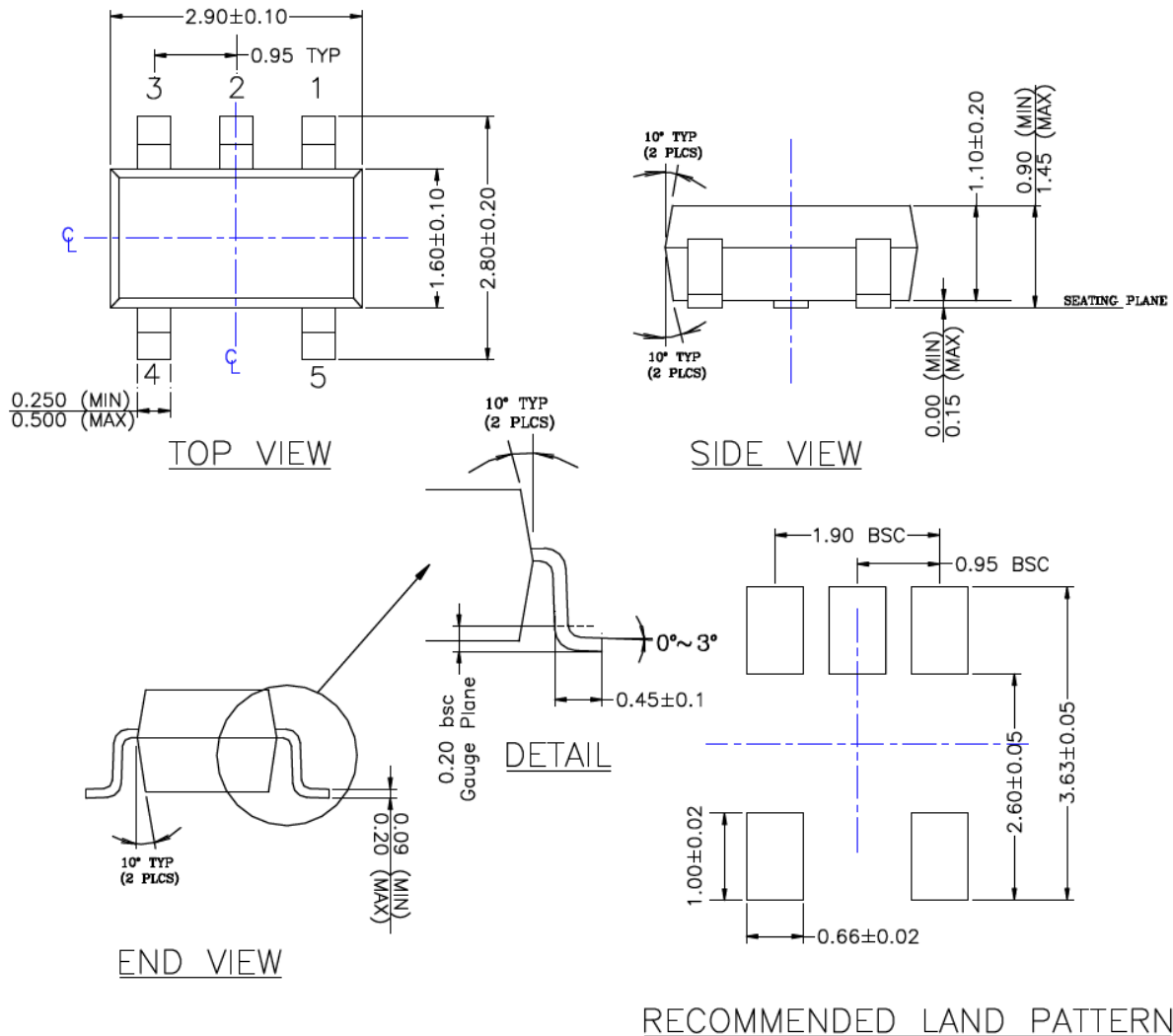
**NOTE:**

1. PACKAGE OUTLINE EXCLUSIVE OF MOLD FLASH & BURR.
2. PACKAGE OUTLINE INCLUSIVE OF SOLER PLATING.
3. DIMENSION AND TOLERANCE PER ANSI Y14.5M, 1982.
4. FOOT LENGTH MEASUREMENT BASED ON GAUGE PLANE METHOD.
5. DIE FACES UP FOR MOLD, AND FACES DOWN FOR TRIM/FORM.
6. ALL DIMENSIONS ARE IN MILLIMETERS.

Note: For the most current package drawings, please see the Microchip Packaging Specification located at <http://www.microchip.com/packaging>.

## Package Outlines and Dimensions

### TITLE

6 LEAD SOT23 PACKAGE OUTLINE & RECOMMENDED LAND PATTERN

DRAWING #	SOT23-6LD-PL-1	UNIT	MM
-----------	----------------	------	----

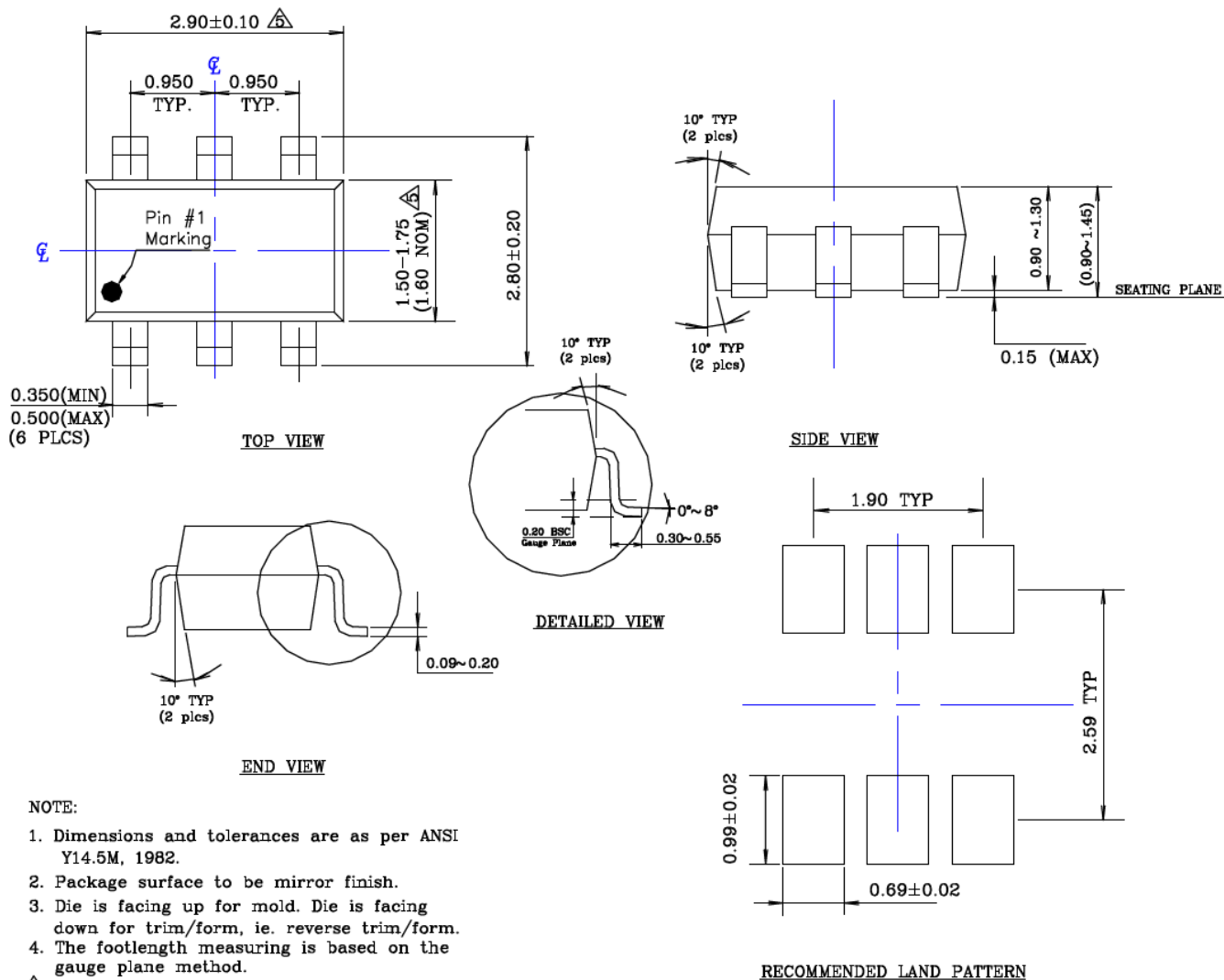

### NOTE:

- Dimensions and tolerances are as per ANSI Y14.5M, 1982.
  - Package surface to be mirror finish.
  - Die is facing up for mold. Die is facing down for trim/form, ie. reverse trim/form.
  - The footlength measuring is based on the gauge plane method.
- $\Delta$  Dimension are exclusive of mold flash & gate burr.

Note: For the most current package drawings, please see the Microchip Packaging Specification located at <http://www.microchip.com/packaging>.

---



---

## Package Outlines and Dimensions

---



---

**TITLE**

8 LEAD SOT23 PACKAGE OUTLINE &amp; RECOMMENDED LAND PATTERN

<b>DRAWING #</b>	SOT23-8LD-PL-1	<b>UNIT</b>	MM
<b>Lead Frame</b>	Copper Alloy	<b>Lead Finish</b>	Matte Tin

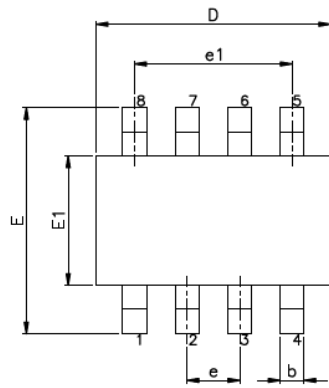

TOP VIEW

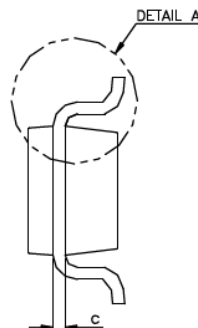

SIDE VIEW

VARIATION (ALL DIMENSIONS SHOWN IN MM)

SYMBOL	MIN.	NOM.	MAX.
A	-	-	1.45
A1	0.00	-	0.15
A2	0.90	1.15	1.30
b	0.22	-	0.38
c	0.08	-	0.22
D	2.90 BSC.		
E	2.80 BSC.		
E1	1.60 BSC.		
e	0.65 BSC.		
e1	1.95 BSC.		
L	0.30	0.45	0.60
L1	0.60 REF.		
L2	0.25 BSC.		
R	0.10	-	-
R1	0.10	-	0.25
$\theta$	0°	4°	8°
$\theta 1$	5°	10°	15°

NOTE :

1. JEDEC OUTLINE : MO-178 BA.

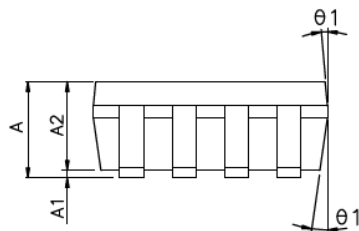

END VIEW

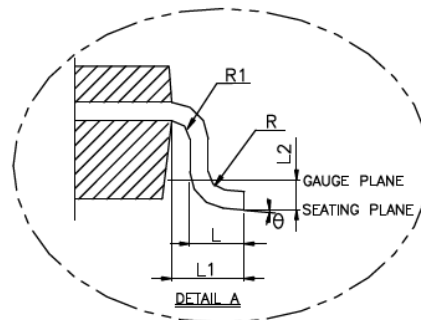

DETAIL A

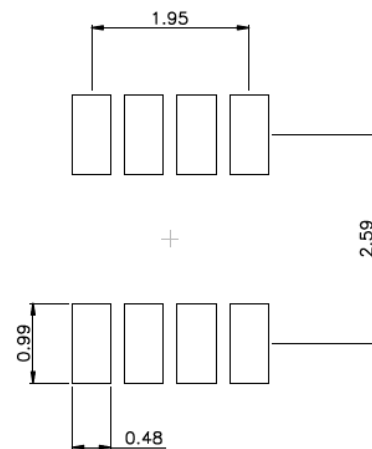

RECOMMENDED LAND PATTERN

Note: For the most current package drawings, please see the Microchip Packaging Specification located at <http://www.microchip.com/packaging>.

## Package Outlines and Dimensions

### TITLE

4 LEAD SOT143 PACKAGE OUTLINE & RECOMMENDED LAND PATTERN

<b>DRAWING #</b>	SOT143-4LD-PL-1	<b>UNIT</b>	MM
------------------	-----------------	-------------	----

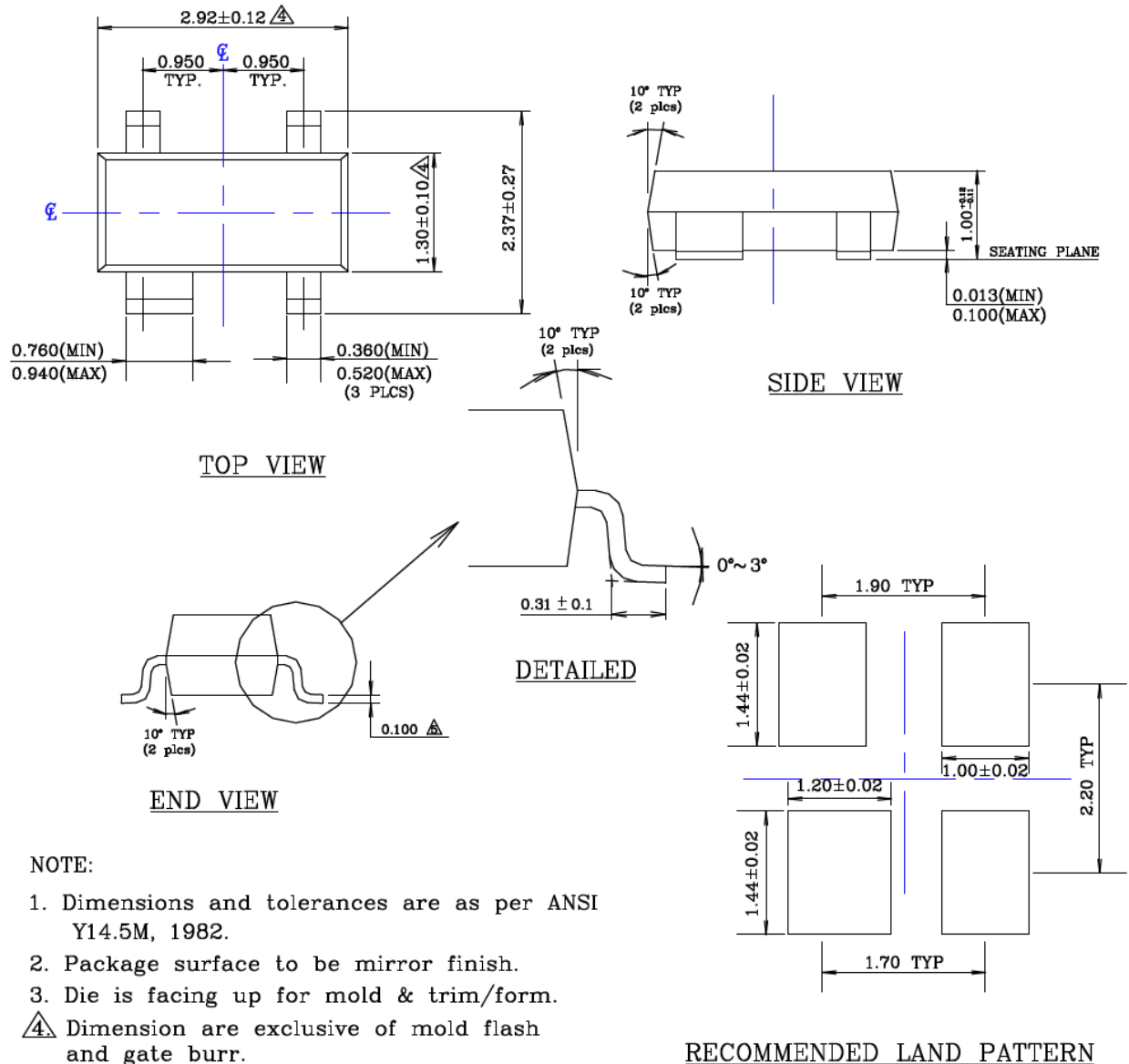

### NOTE:

- Dimensions and tolerances are as per ANSI Y14.5M, 1982.
- Package surface to be mirror finish.
- Die is facing up for mold & trim/form.
- $\Delta$  Dimension are exclusive of mold flash and gate burr.
- $\Delta$  Dimension are exclusive of solder plating.

Note: For the most current package drawings, please see the Microchip Packaging Specification located at <http://www.microchip.com/packaging>.

---



---

## Package Outlines and Dimensions

---



---

**TITLE**

3 LEAD SOT223 PACKAGE OUTLINE &amp; RECOMMENDED LAND PATTERN

<b>DRAWING #</b>	SOT223-3LD-PL-1	<b>UNIT</b>	MM
------------------	-----------------	-------------	----

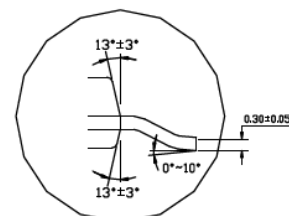
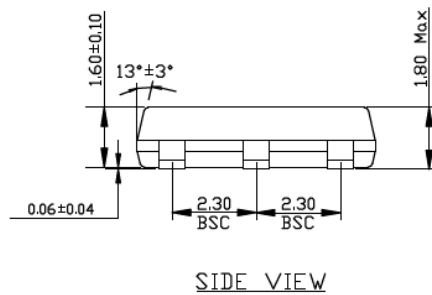
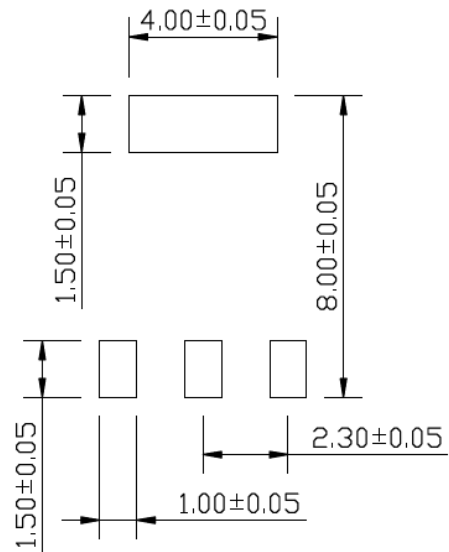
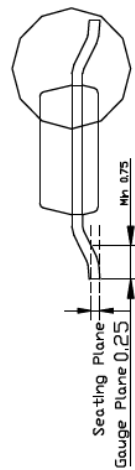
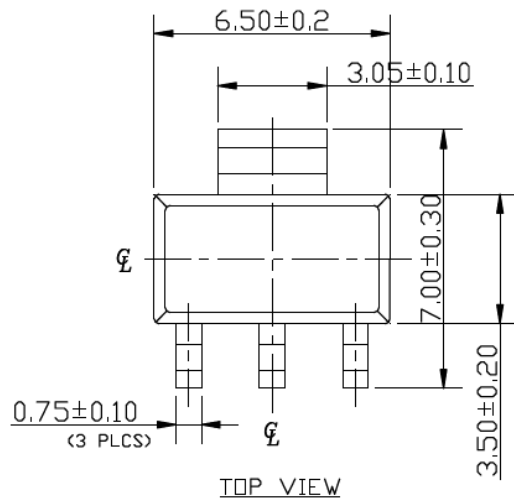
**NOTE:**

1. Dimensions and tolerances are as per ANSI Y14.5M, 1982.
2. Controlling dimension: Millimeters.
3. Dimensions are exclusive of mold flash and gate burr.
4. All specification comply to Jedec spec T0261 Issue C.

Note: For the most current package drawings, please see the Microchip Packaging Specification located at <http://www.microchip.com/packaging>.



**MICROCHIP**

---

---

**Package Outlines and Dimensions**

---

---

NOTES:

---

---

**Package Outlines and Dimensions**

---

---

**SPAK**

Micrel Legacy

## Package Outlines and Dimensions

### TITLE

3 LEAD SPAK PACKAGE OUTLINE & RECOMMENDED LAND PATTERN

<b>DRAWING #</b>	SPAK-3LD-PL-1	<b>UNIT</b>	INCH/MM
------------------	---------------	-------------	---------

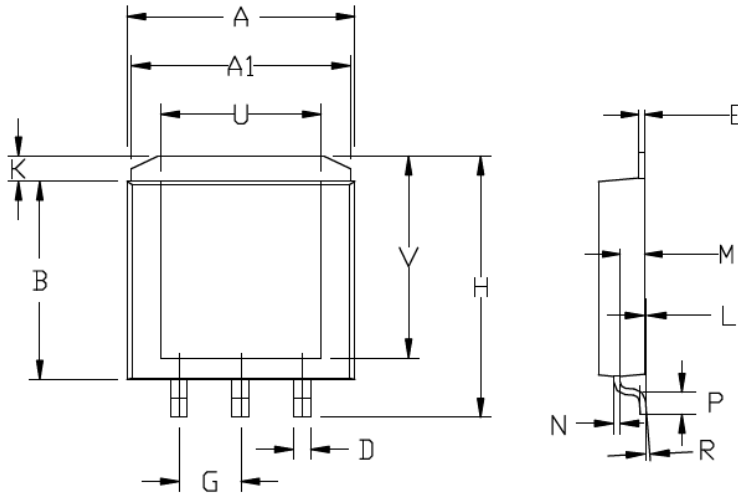

	INCHES		MILLIMETERS	
A	0.365	0.375	9.27	9.52
A1	0.350	0.360	8.89	9.14
B	0.310	0.320	7.87	8.13
C	0.070	0.080	1.78	2.03
D	0.025	0.031	0.63	0.79
E	0.010	BSC	0.25	BSC
G	0.100	BSC	2.54	BSC
H	0.410	0.420	10.41	10.67
K	0.030	0.050	0.76	1.27
L	0.001	0.005	0.03	0.13
M	0.035	0.045	0.89	1.14
N	0.010	BSC	0.25	BSC
P	0.031	0.041	0.79	1.04
R	0°	6°	0°	6°
U	0.256	BSC	6.50	BSC
V	0.316	BSC	8.03	BSC

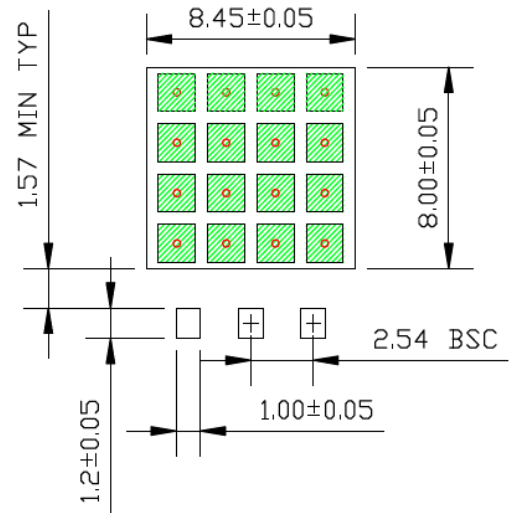
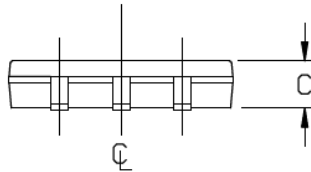

RECOMMENDED LAND PATTERN (UNIT: MM)

- NOTE:
1. DIMENSION DOES NOT INCLUDE MOLD FLASH OR PROTRUSIONS.
  2. DIMENSION INCLUDES PLATING THICKNESS. SOLDER MASK OPENING
  3. RED CIRCLES IN LAND PATTERN REPRESENT THERMAL VIA, 0.30MM IN DIAMETER & SHOULD BE CONNECTED TO GND FOR MAXIMUM PERFORMANCE
  4. GREEN RECTANGLES IN LAND PATTERN REPRESENT SOLDER STENCIL OPENING (OPTIONAL), 1.50X1.50MM.

Note: For the most current package drawings, please see the Microchip Packaging Specification located at <http://www.microchip.com/packaging>.



## Package Outlines and Dimensions

**TITLE**

5 LEAD SPAK PACKAGE OUTLINE &amp; RECOMMENDED LAND PATTERN

<b>DRAWING #</b>	SPAK-5LD-PL-1	<b>UNIT</b>	MM
------------------	---------------	-------------	----

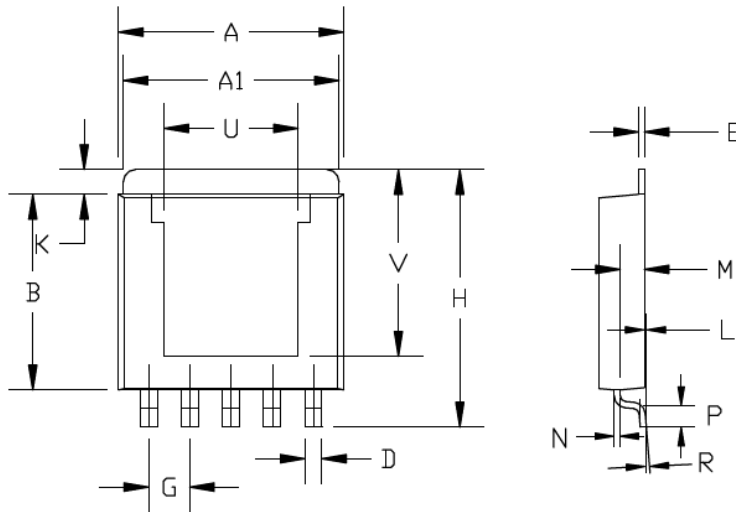

	INCHES		MILLIMETERS	
A	0.365	0.375	9.27	9.52
A1	0.350	0.360	8.89	9.14
B	0.310	0.320	7.87	8.13
C	0.070	0.080	1.78	2.03
D	0.025	0.031	0.63	0.79
E	0.010	BSC	0.25	BSC
G	0.067	BSC	1.70	BSC
H	0.410	0.420	10.41	10.67
K	0.030	0.050	0.76	1.27
L	0.001	0.005	0.03	0.13
M	0.035	0.045	0.89	1.14
N	0.010	BSC	0.25	BSC
P	0.031	0.041	0.79	1.04
R	0°	6°	0°	6°
U	0.220	BSC	5.58	BSC
V	0.296	BSC	7.52	BSC

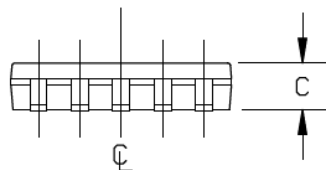

- NOTE:**
1. DIMENSION DOES NOT INCLUDE MOLD FLASH OR PROTRUSIONS.
  2. DIMENSION INCLUDES PLATING THICKNESS. SOLDER MASK OPENING
  3. RED CIRCLES IN LAND PATTERN REPRESENT THERMAL VIA, 0.30MM IN DIAMETER & SHOULD BE CONNECTED TO GND FOR MAXIMUM PERFORMANCE
  4. GREEN RECTANGLES IN LAND PATTERN REPRESENT SOLDER STENCIL OPENING (OPTIONAL), 1.50X1.50MM.

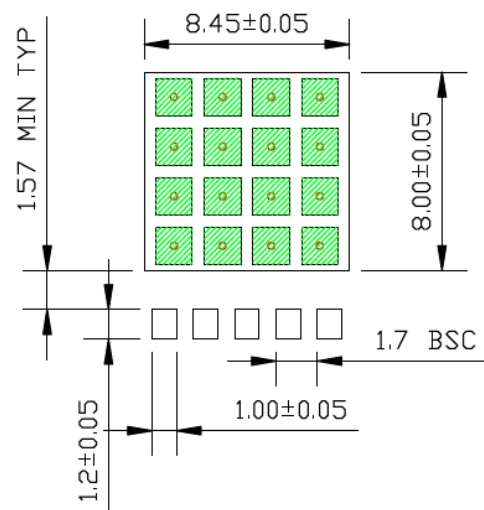

RECOMMENDED  
LAND PATTERN

Note: For the most current package drawings, please see the Microchip Packaging Specification located at <http://www.microchip.com/packaging>.

## Package Outlines and Dimensions

### TITLE

7 LEAD SPAK PACKAGE OUTLINE & RECOMMENDED LAND PATTERN

<b>DRAWING #</b>	SPAK-7LD-PL-1	<b>UNIT</b>	INCH/MM
------------------	---------------	-------------	---------

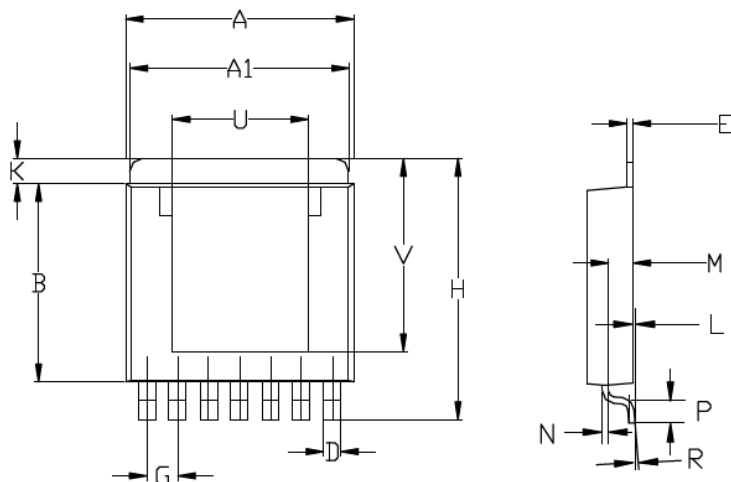

	INCHES		MILLIMETERS	
A	0.365	0.375	9.27	9.52
A1	0.350	0.360	8.89	9.14
B	0.310	0.320	7.87	8.13
C	0.070	0.080	1.78	2.03
D	0.025	0.031	0.63	0.79
E	0.010	BSC	0.25	BSC
G	0.050	BSC	1.27	BSC
H	0.410	0.420	10.41	10.67
K	0.030	0.050	0.76	1.27
L	0.001	0.005	0.03	0.13
M	0.035	0.045	0.89	1.14
N	0.010	BSC	0.25	BSC
P	0.031	0.041	0.79	1.04
R	0°	6°	0°	6°
U	0.220	BSC	5.58	BSC
V	0.296	BSC	7.52	BSC

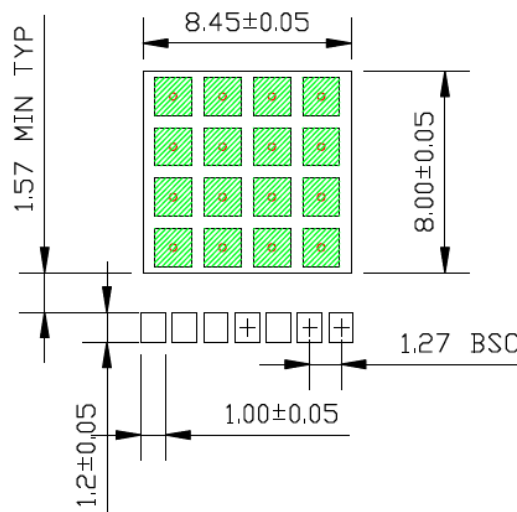
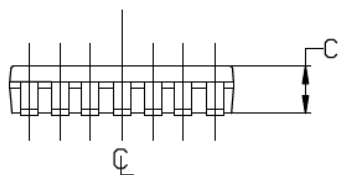

RECOMMENDED LAND PATTERN (UNIT: MM)

### NOTE:

1. DIMENSION DOES NOT INCLUDE MOLD FLASH OR PROTRUSIONS.
2. DIMENSION INCLUDES PLATING THICKNESS. SOLDER MASK OPENING
3. RED CIRCLES IN LAND PATTERN REPRESENT THERMAL VIA, 0.30MM IN DIAMETER & SHOULD BE CONNECTED TO GND FOR MAXIMUM PERFORMANCE
4. GREEN RECTANGLES IN LAND PATTERN REPRESENT SOLDER STENCIL OPENING (OPTIONAL), 1.50X1.50MM.

Note: For the most current package drawings, please see the Microchip Packaging Specification located at <http://www.microchip.com/packaging>.

---

---

**Package Outlines and Dimensions**

---

---

**SSOP**

Micrel Legacy

## Package Outlines and Dimensions

### TITLE

16 LEAD SSOP PACKAGE OUTLINE & RECOMMENDED LAND PATTERN

DRAWING #	SSOP-16LD-PL-1	UNIT	INCH [MM]
-----------	----------------	------	-----------

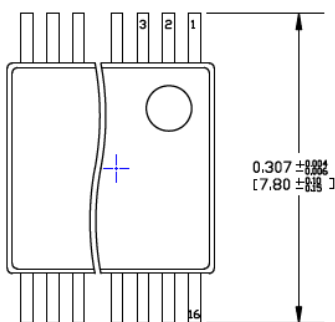

**TOP VIEW**  
NOTE: 1, 2

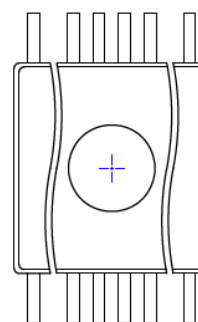

**BOTTOM VIEW**  
NOTE: 1, 2

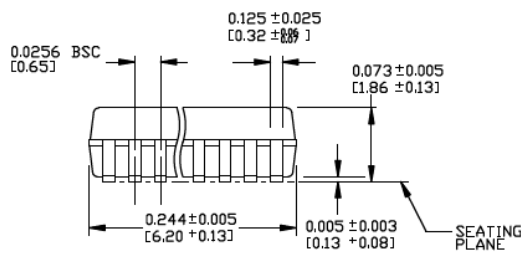

**SIDE VIEW**  
NOTE: 1, 2

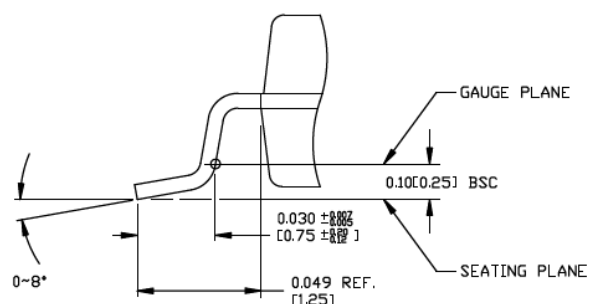

**DETAIL 'A'**

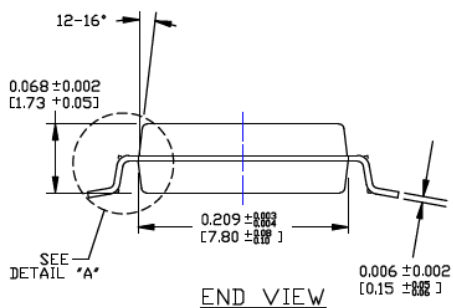

**END VIEW**  
NOTE: 1, 2, 3

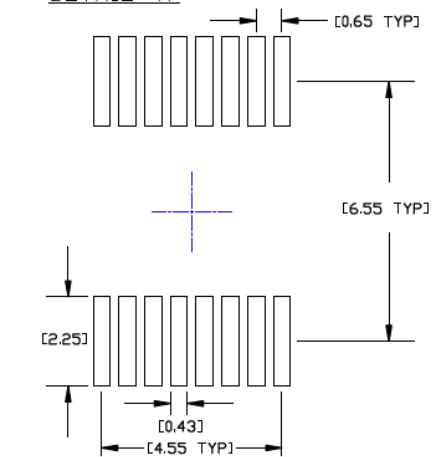

**RECOMMENDED LAND PATTERN**

### NOTES:

1. DIMENSIONS ARE INCHES [MM].
2. CONTROL DIMENSION: MILLIMETERS.
3. DIMENSION DOES NOT INCLUDE MOLD FLASH OR PROTRUSIONS, EITHER OR WHICH SHALL NOT EXCEED 0.006 [0.15] PER SIDE.

Note: For the most current package drawings, please see the Microchip Packaging Specification located at <http://www.microchip.com/packaging>.

## Package Outlines and Dimensions

**TITLE**

20 LEAD SSOP PACKAGE OUTLINE & RECOMMENDED LAND PATTERN

<b>DRAWING #</b>	SSOP-20LD-PL-1	<b>UNIT</b>	MM
------------------	----------------	-------------	----

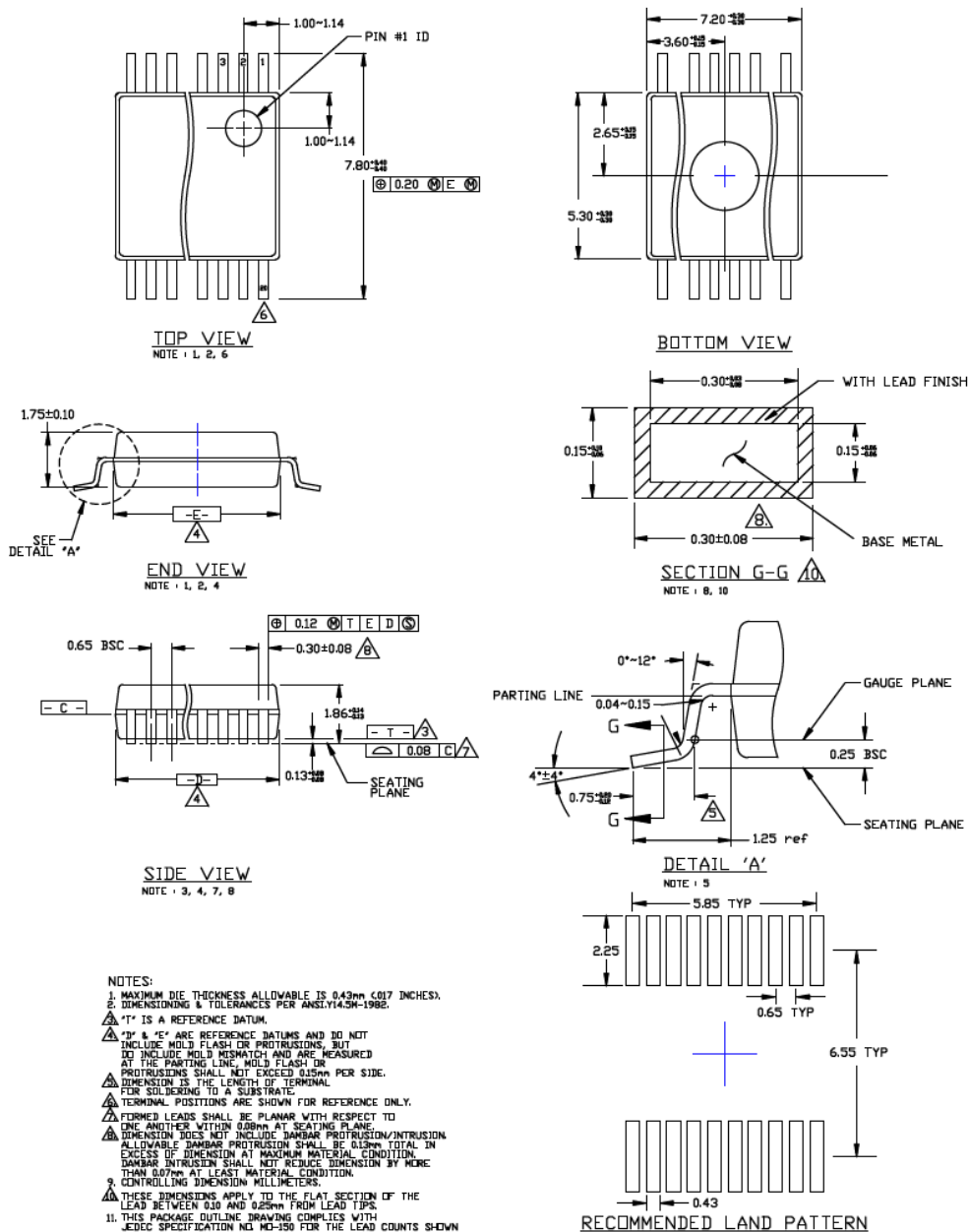

Note: For the most current package drawings, please see the Microchip Packaging Specification located at <http://www.microchip.com/packaging>.

## Package Outlines and Dimensions

### TITLE

24 LEAD SSOP PACKAGE OUTLINE & RECOMMENDED LAND PATTERN

DRAWING #	SSOP-24LD-PL-1	UNIT	MM
-----------	----------------	------	----

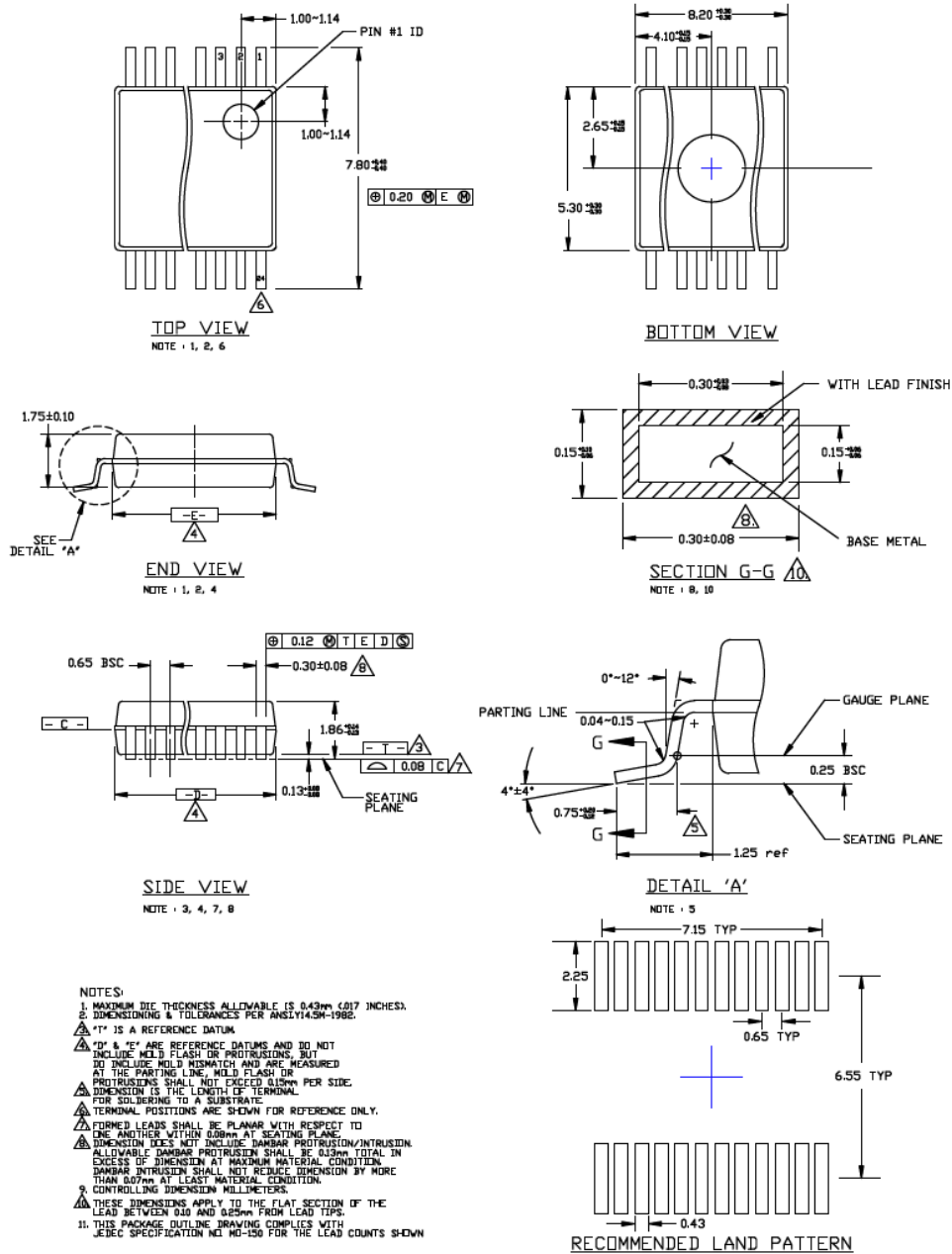

Note: For the most current package drawings, please see the Microchip Packaging Specification located at <http://www.microchip.com/packaging>.

## Package Outlines and Dimensions

**TITLE**

28 LEAD SSOP PACKAGE OUTLINE & RECOMMENDED LAND PATTERN

<b>DRAWING #</b>	SSOP-28LD-PL-1	<b>UNIT</b>	MM
------------------	----------------	-------------	----

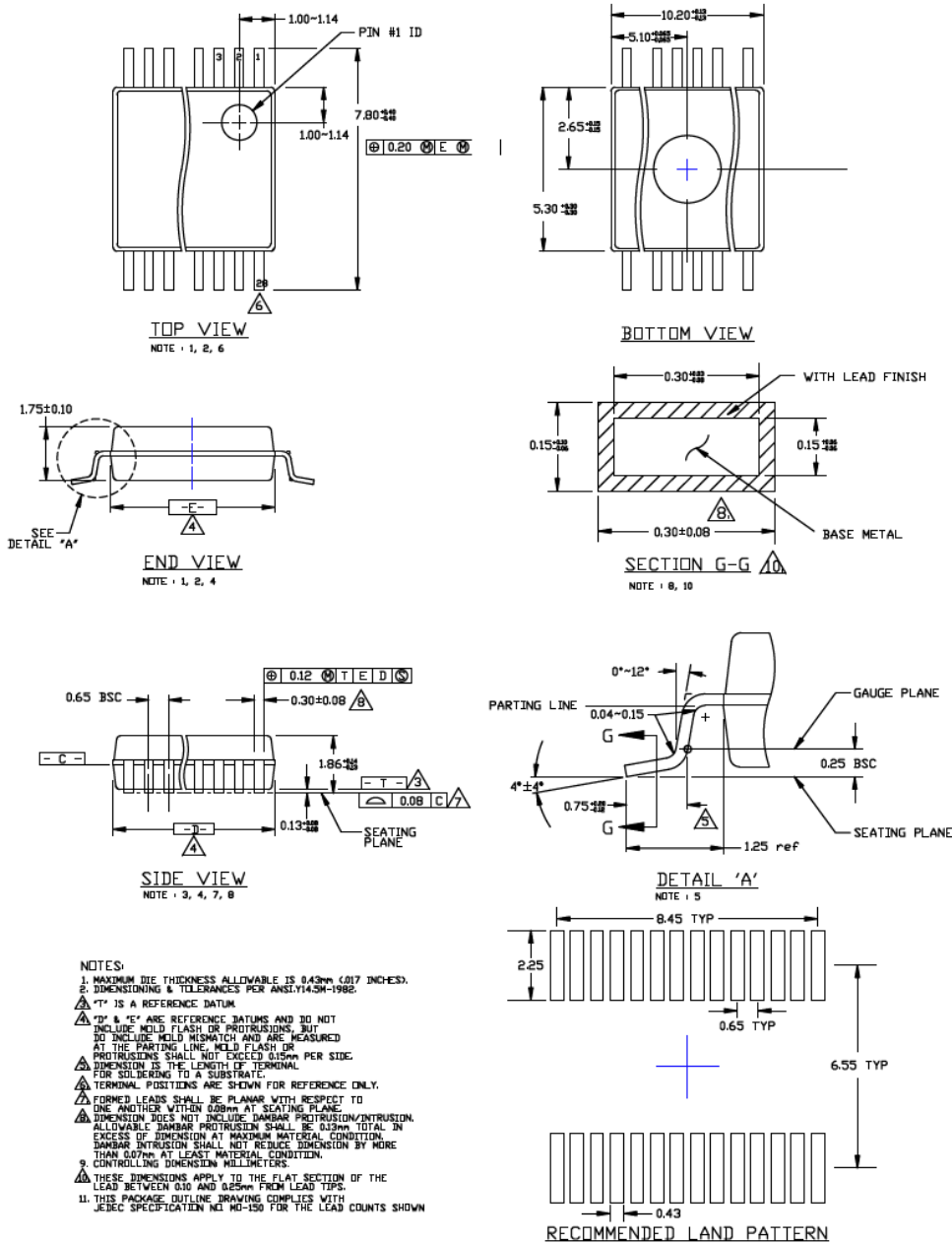

Note: For the most current package drawings, please see the Microchip Packaging Specification located at <http://www.microchip.com/packaging>.

## Package Outlines and Dimensions

### TITLE

48 LEAD SSOP PACKAGE OUTLINE & RECOMMENDED LAND PATTERN

<b>DRAWING #</b>	SSOP-48LD-PL-1	<b>UNIT</b>	MM
------------------	----------------	-------------	----

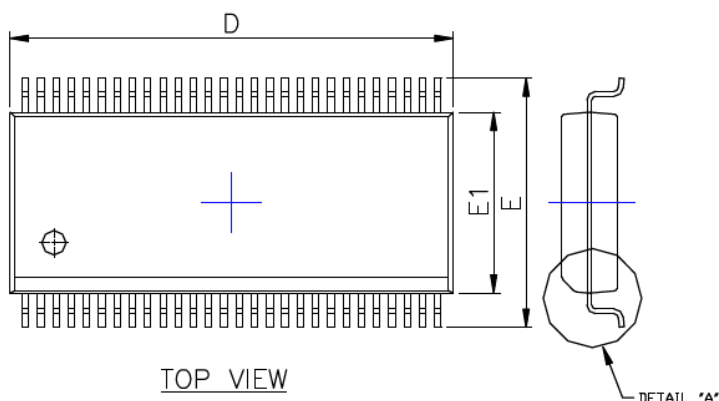

TOP VIEW

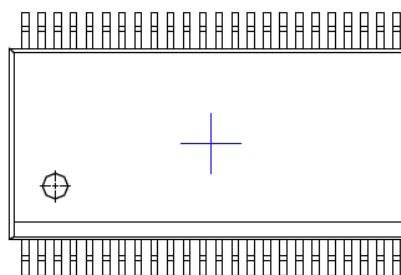

BOTTOM VIEW

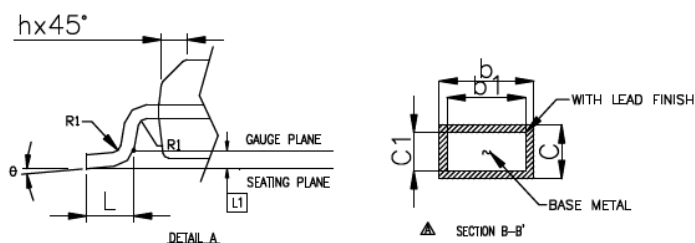

DETAILED VIEW

SYMBOL	DIMENSION IN MM			DIMENSION IN INCH		
	MIN.	NOM.	MAX.	MIN.	NOM.	MAX.
A	2.413	2.591	2.794	0.095	0.102	0.110
A1	0.203	0.305	0.406	0.008	0.012	0.016
b	0.203		0.343	0.008		0.014
b1	0.203	0.254	0.305	0.008	0.010	0.012
c	0.127		0.254	0.005		0.010
c1	0.127		0.216	0.005		0.009
E	10.058	10.312	10.566	0.396	0.406	0.416
E1	7.391	7.493	7.595	0.291	0.295	0.299
e	0.635 BASIC			0.025 BASIC		
h	0.381		0.635	0.015		0.025
L	0.508		1.016	0.020		0.040
L1	0.254 BASIC			0.010 BASIC		
R1						
θ	0		5	0		5
D	15.748	15.875	16.002			

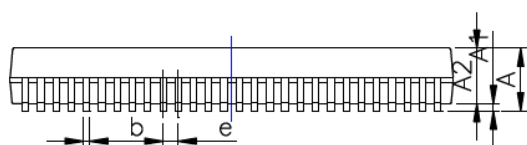

SIDE VIEW

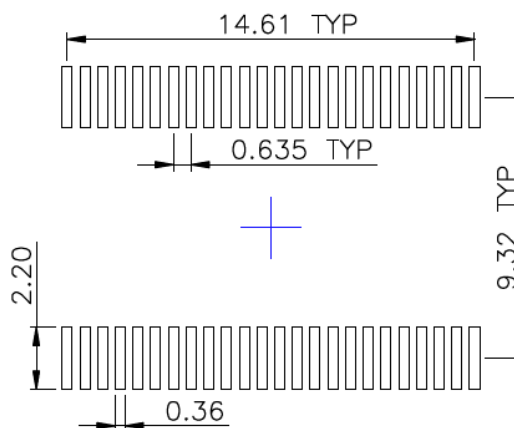

RECOMMENDED LAND PATTERN

NOTES :

1. THE DIAGRAMS DO NOT REPRESENT THE ACTUAL PIN COUNT.

Note: For the most current package drawings, please see the Microchip Packaging Specification located at <http://www.microchip.com/packaging>.



---

---

**Package Outlines and Dimensions**

---

---

**TDFN**

Micrel Legacy

**Package Outlines and Dimensions**

**TITLE**

6 LEAD TDFN 2x2mm PACKAGE OUTLINE & RECOMMENDED LAND PATTERN (0.65mm lead pitch)

DRAWING #	TDFN22-6LD-PL-1	UNIT	MM
-----------	-----------------	------	----

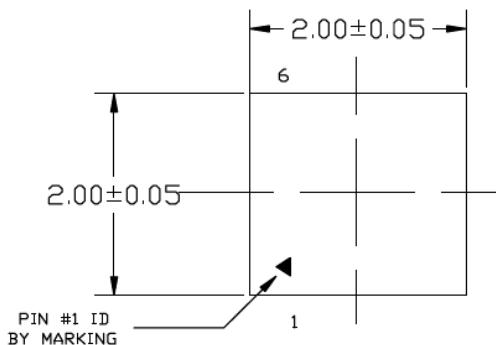

TOP VIEW  
NOTE: 1, 2, 3

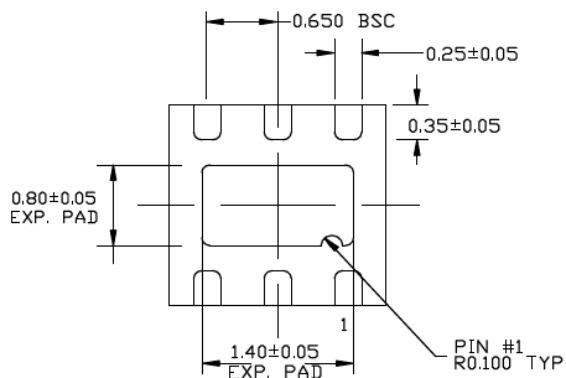

BOTTOM VIEW  
NOTE: 1, 2, 3

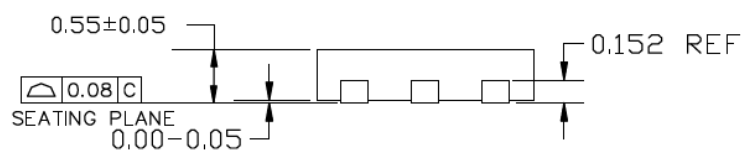

END VIEW  
NOTE: 1, 2, 3

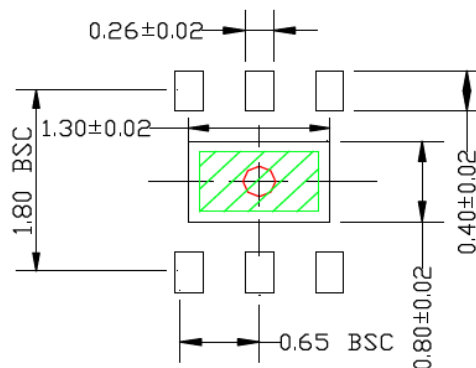

RECOMMENDED LAND PATTERN  
NOTE: 4, 5

- NOTE:
1. MAX PACKAGE WARPAGE IS 0.08 MM
  2. MAX ALLOWABLE BURR IS 0.076MM IN ALL DIRECTIONS
  3. PIN #1 IS ON TOP WILL BE LASER MARKED
  4. RED CIRCLE IN LAND PATTERN REPRESENTS THERMAL VIA. SIZE SHOULD BE 0.30-0.3 MM IN DIAMETER AND SHOULD BE CONNECTED TO GND FOR MAX THERMAL PERFORMANCE.
  5. GREEN RECTANGLES (SHADED AREA) REPRESENTS SOLDER STENCIL OPENING ON EXPOSED PAD AREA. SIZE SHOULD BE 1.10x0.60 MM.

Note: For the most current package drawings, please see the Microchip Packaging Specification located at <http://www.microchip.com/packageing>.

---



---

## Package Outlines and Dimensions

---



---

**TITLE**

6 LEAD TDFN 2X2mm (0.50mm LEAD PITCH) PACKAGE OUTLINE &amp; RECOMMENDED LAND PATTERN

DRAWING #	TDFN22-6LD-PL-2	UNIT	MM
-----------	-----------------	------	----

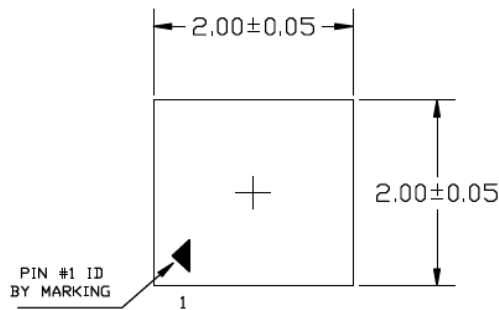

TOP VIEW  
NOTE: 1, 2, 3

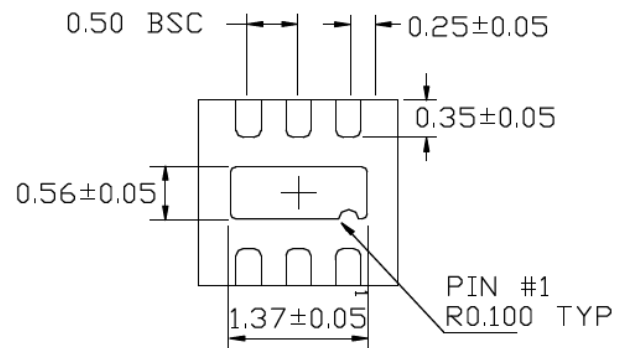

BOTTOM VIEW  
NOTE: 1, 2, 3

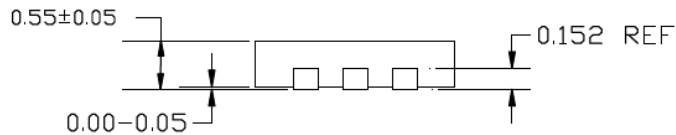

SIDE VIEW  
NOTE: 1, 2, 3

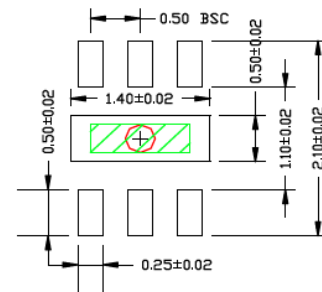

RECOMMENDED LAND PATTERN  
NOTE: 4, 5

**NOTE:**

1. MAX PACKAGE WARPAGE IS 0.05 MM
2. MAX ALLOWABLE BURR IS 0.076MM IN ALL DIRECTIONS
3. PIN #1 IS ON TOP WILL BE LASER MARKED
4. RED CIRCLE IN LAND PATTERN INDICATE THERMAL VIA. SIZE SHOULD BE 0.30-0.3MM IN DIAMETER AND SHOULD BE CONNECTED TO GND FOR MAX THERMAL PERFORMANCE
5. GREEN RECTANGLE (SHADED AREA) REPRESENTS OPTIONAL SOLDER STENCIL OPENING ON EXPOSED PAD AREA. RECOMMENDED SIZE IS 1.00x0.30 MM.

Note: For the most current package drawings, please see the Microchip Packaging Specification located at <http://www.microchip.com/packaging>.

**Package Outlines and Dimensions**

**TITLE**

8 LEAD TDFN 2x2mm PACKAGE OUTLINE & RECOMMENDED LAND PATTERN

DRAWING #	TDFN22-8LD-PL-1	UNIT	MM
-----------	-----------------	------	----

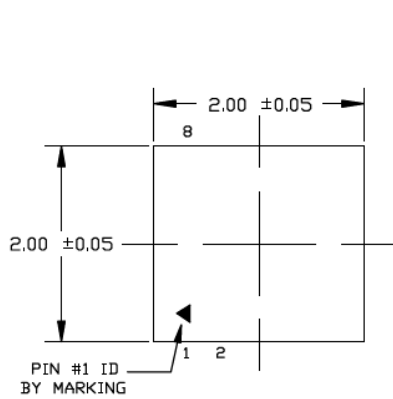

TOP VIEW  
NOTE: 1, 2, 3

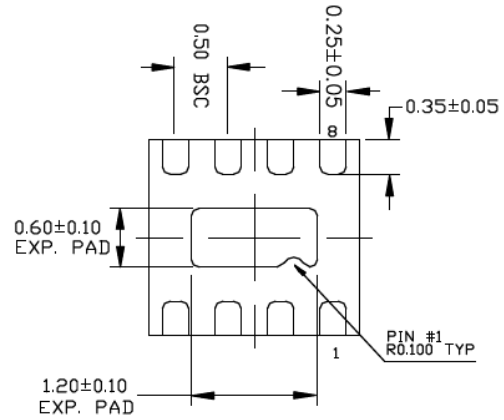

BOTTOM VIEW  
NOTE: 1, 2, 3

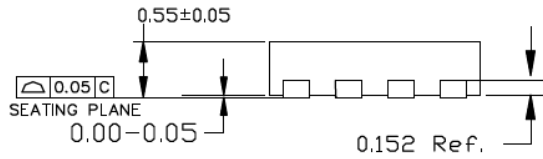

END VIEW  
NOTE: 1, 2, 3

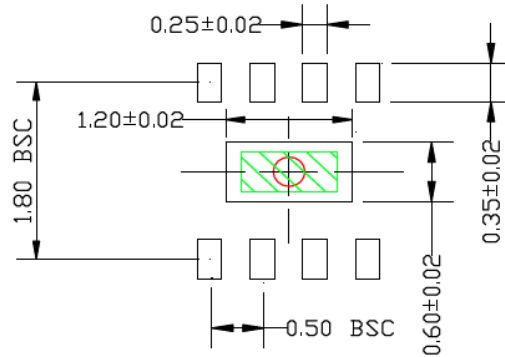

RECOMMENDED LAND PATTERN  
NOTE: 4, 5

- NOTE:
1. MAX PACKAGE WARPAGE IS 0.05 MM
  2. MAX ALLOWABLE BURR IS 0.076MM IN ALL DIRECTIONS
  3. PIN #1 IS ON TOP WILL BE LASER MARKED
  4. RED CIRCLE IN LAND PATTERN REPRESENTS THERMAL VIA. SIZE SHOULD BE 0.30-0.3 MM IN DIAMETER AND SHOULD BE CONNECTED TO GND FOR MAX THERMAL PERFORMANCE
  5. GREEN RECTANGLES (SHADED AREA) REPRESENTS SOLDER STENCIL OPENING ON EXPOSED PAD AREA. SIZE SHOULD BE 0.40x0.90 MM.

Note: For the most current package drawings, please see the Microchip Packaging Specification located at <http://www.microchip.com/packaging>.

---



---

## Package Outlines and Dimensions

---



---

**TITLE**

10 LEAD TDFN 2.0x2.0mm PACKAGE OUTLINE &amp; RECOMMENDED LAND PATTERN

DRAWING #	TDFN22-10LD-PL-1	UNIT	MM
-----------	------------------	------	----

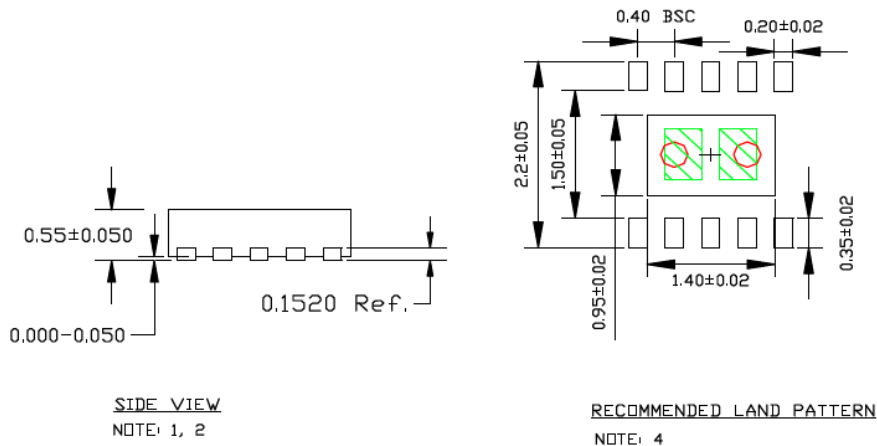
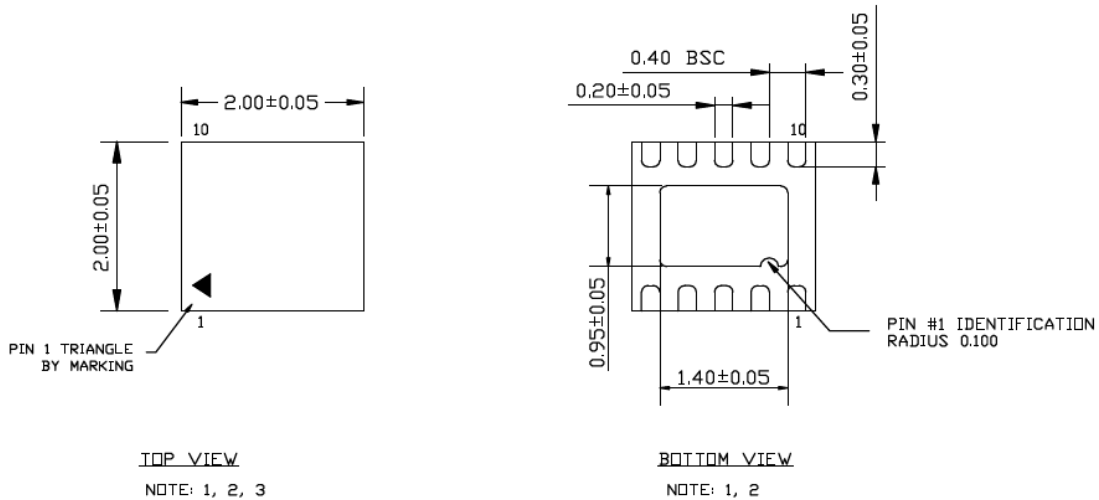
**NOTE:**

1. MAX PACKAGE WARPAGE IS 0.05MM
2. MAX ALLOWABLE BURR IS 0.076MM IN ALL DIRECTIONS
3. PIN #1 IS ON TOP WILL BE LASER MARKED
4. GREEN RECTANGLES (SHADED AREA) INDICATE STENCIL OPENING ON EXPOSED AREA. SIZE IS 0.6X0.4MM, SPACING IS 0.2MM.
5. RED CIRCLES REPRESENT THERMAL VIAS AND SHOULD BE CONNECTED TO GND FOR MAX PERFORMANCE. 0.30 - 0.35 MM RECOMMENDED DIAMETER, 0.80 MM PITCH.

Note: For the most current package drawings, please see the Microchip Packaging Specification located at <http://www.microchip.com/packaging>.

## Package Outlines and Dimensions

### TITLE

4 LEAD TDFN 1.0x1.0mm PACKAGE OUTLINE & RECOMMENDED LAND PATTERN

DRAWING #	TDFN1010-4LD-PL-2	UNIT	MM
-----------	-------------------	------	----

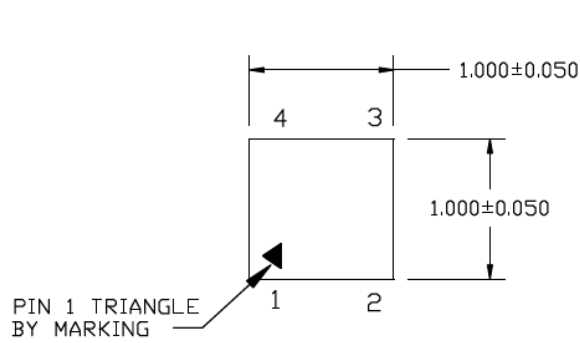

TOP VIEW

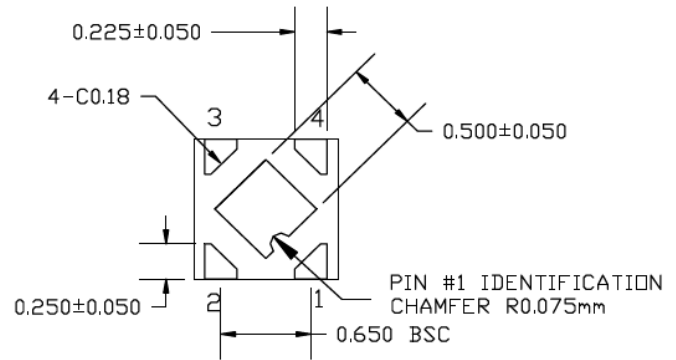

BOTTOM VIEW

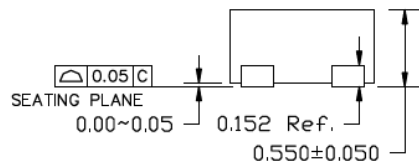

SIDE VIEW

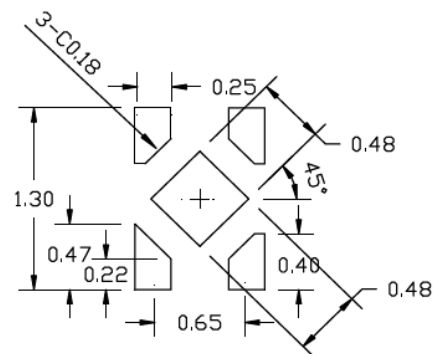

RECOMMENDED LAND PATTERN

### NOTE:

1. MAX PACKAGE WARPAGE IS 0.05 MM
2. MAX ALLOWABLE BURR IS 0.076MM IN ALL DIRECTIONS
3. PIN #1 IS ON TOP WILL BE LASER MARKED
4. UNSPECIFIED TOLERANCE IS +/- 0.05 MM

Note: For the most current package drawings, please see the Microchip Packaging Specification located at <http://www.microchip.com/package>.

**Package Outlines and Dimensions**

**TITLE**

4 LEAD TDFN 1.2x1.2mm PACKAGE OUTLINE & RECOMMENDED LAND PATTERN

DRAWING #	TDFN1212-4LD-PL-1	UNIT	MM
-----------	-------------------	------	----

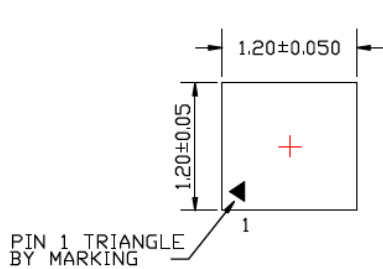

TOP VIEW

NOTE: 1, 2, 3

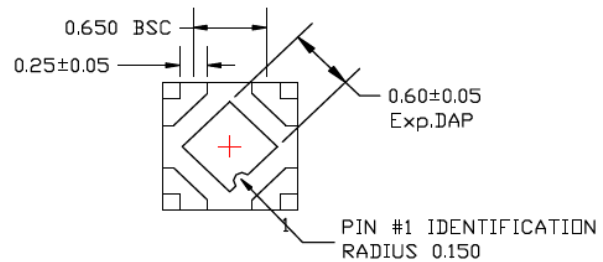

BOTTOM VIEW

NOTE: 1, 2, 3

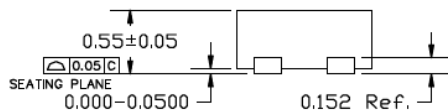

SIDE VIEW

NOTE: 1, 2, 3

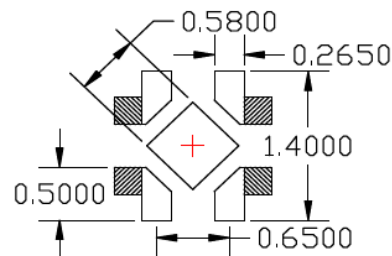

RECOMMENDED LAND PATTERN

NOTE: 4

NOTE:

1. MAX PACKAGE WARPAGE IS 0.05 MM
2. MAX ALLOWABLE BURR IS 0.076MM IN ALL DIRECTIONS
3. PIN #1 IS ON TOP WILL BE LASER MARKED
4. SHADED AREA INDICATE SOLDER STENCIL OPENING (OPTIONAL) FOR IMPROVED THERMAL PERFORMANCE

Note: For the most current package drawings, please see the Microchip Packaging Specification located at <http://www.microchip.com/packaging>.

## Package Outlines and Dimensions

### TITLE

6 LEAD TDFN 1.2x1.2mm PACKAGE OUTLINE & RECOMMENDED LAND PATTERN

DRAWING #	TDFN1212-6LD-PL-1	UNIT	MM
-----------	-------------------	------	----

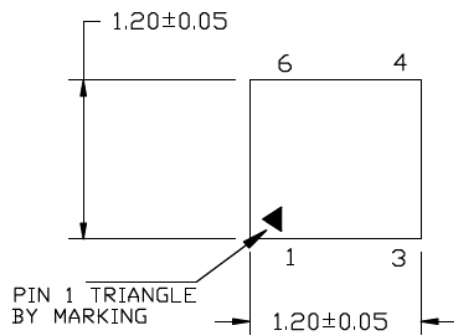

TOP VIEW

NOTE: 1, 2, 3

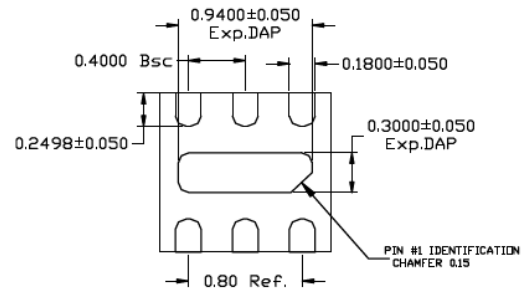

BOTTOM VIEW

NOTE: 1, 2, 3

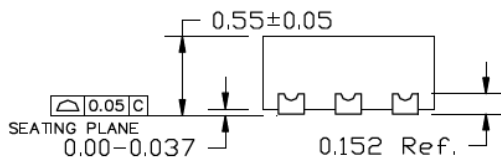

SIDE VIEW

NOTE: 1, 2, 3

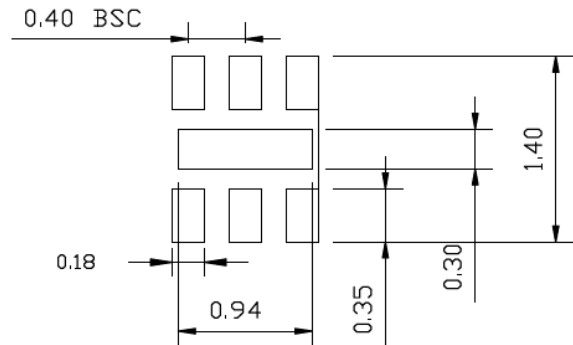

RECOMMENDED LAND PATTERN

### NOTE:

1. MAX PACKAGE WARPAGE IS 0.05 MM
2. MAX ALLOWABLE BURR IS 0.076MM IN ALL DIRECTIONS
3. PIN #1 IS ON TOP WILL BE LASER MARKED

Note: For the most current package drawings, please see the Microchip Packaging Specification located at <http://www.microchip.com/packaging>.



---



---

## Package Outlines and Dimensions

---



---

**TITLE**

4 LEAD TDFN 1.2x1.6mm PACKAGE OUTLINE &amp; RECOMMENDED LAND PATTERN

<b>DRAWING #</b>	TDFN1216-4LD-PL-1
------------------	-------------------

<b>UNIT</b>	MM
-------------	----

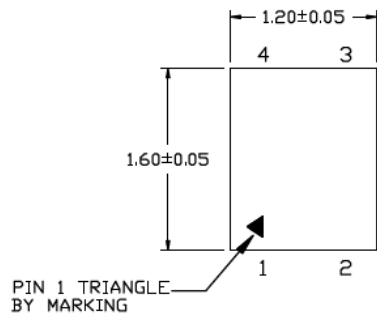

TOP VIEW

NOTE: 1, 2, 3

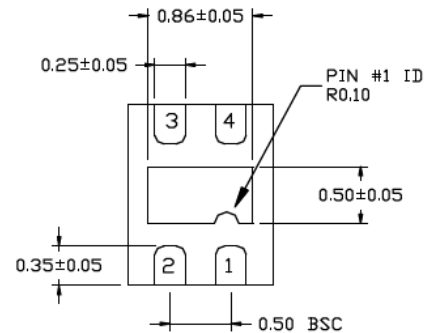

BOTTOM VIEW

NOTE: 1, 2, 3

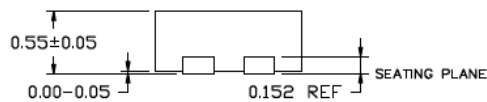

SIDE VIEW

NOTE: 1, 2, 3

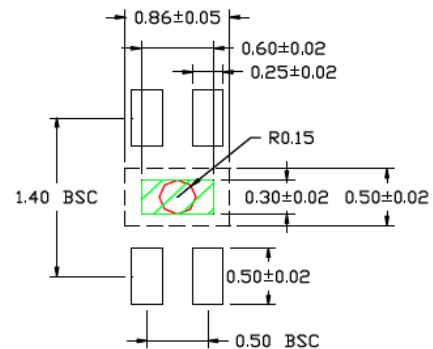

RECOMMENDED LAND PATTERN

NOTE: 4, 5

**NOTE:**

1. MAX PACKAGE WARPAGE IS 0.05mm.
2. MAX ALLOWABLE BURR IS 0.076mm IN ALL DIRECTIONS.
3. PIN #1 IS ON TOP WILL BE LASER MARKED.
4. GREEN SHADED AREA INDICATES SOLDER STENCIL OPENING (OPTIONAL) FOR IMPROVED THERMAL PERFORMANCE. RECOMMENDED SIZE IS 0.60mm x 0.30mm.
5. RED CIRCLE REPRESENTS THERMAL VIA & SHOULD BE CONNECTED TO GND FOR MAX PERFORMANCE. RECOMMENDED DIAMETER IS 0.30mm - 0.35mm.

Note: For the most current package drawings, please see the Microchip Packaging Specification located at <http://www.microchip.com/packaging>.

## Package Outlines and Dimensions

### TITLE

8 LEAD TDFN 1.6x1.2mm PACKAGE OUTLINE & RECOMMENDED LAND PATTERN

DRAWING #	TDFN1612-8LD-PL-1	UNIT	MM
-----------	-------------------	------	----

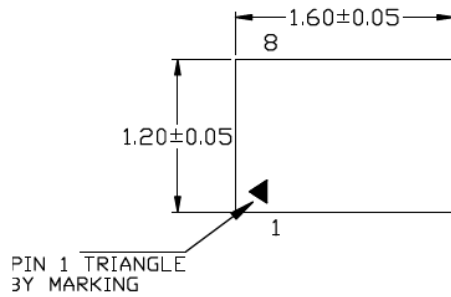

TOP VIEW

NOTE: 1, 2, 3

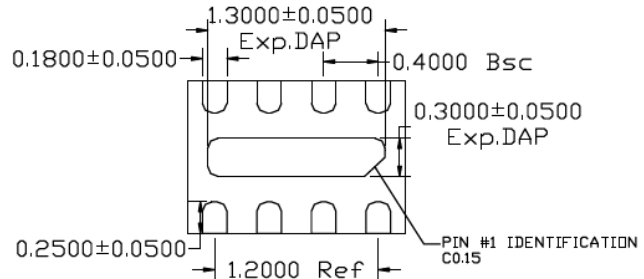

BOTTOM VIEW

NOTE: 1, 2, 3

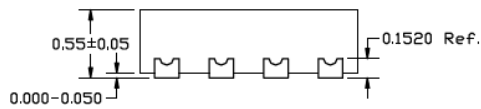

SIDE VIEW

NOTE: 1, 2, 3

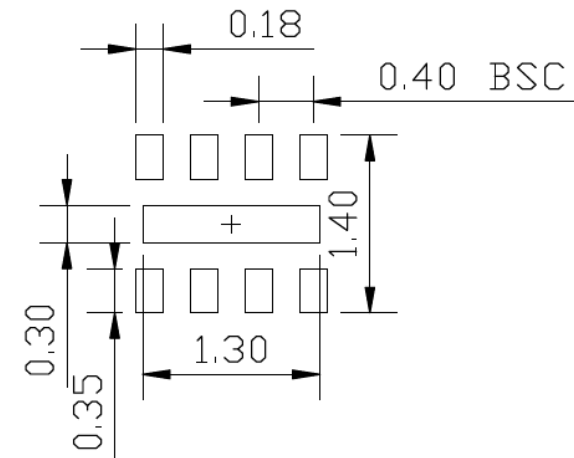

RECOMMENDED LAND PATTERN

### NOTE:

1. MAX PACKAGE WARPAGE IS 0.05 MM
2. MAX ALLOWABLE BURR IS 0.076MM IN ALL DIRECTIONS
3. PIN #1 IS ON TOP WILL BE LASER MARKED

Note: For the most current package drawings, please see the Microchip Packaging Specification located at <http://www.microchip.com/packaging>.

**Package Outlines and Dimensions**

**TITLE**

6 LEAD TDFN 1.6x1.6mm PACKAGE OUTLINE & RECOMMENDED LAND PATTERN

<b>DRAWING #</b>	TDFN1616-6LD-PL-1	<b>UNIT</b>	MM
------------------	-------------------	-------------	----

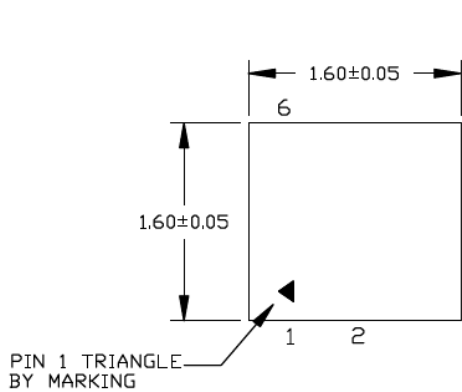

TOP VIEW  
NOTE: 1, 2, 3

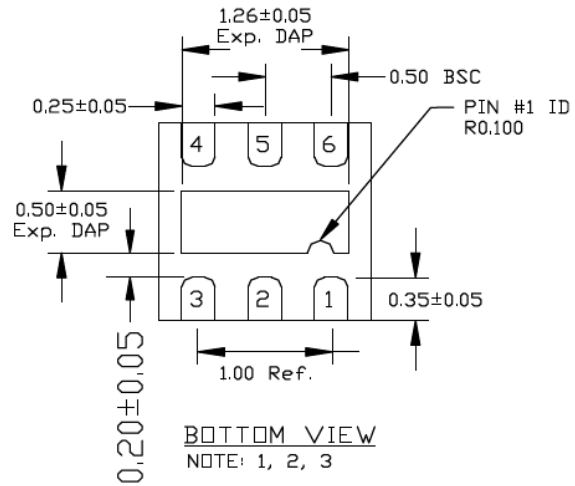

BOTTOM VIEW  
NOTE: 1, 2, 3

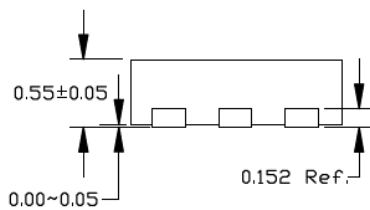

SIDE VIEW  
NOTE: 1, 2, 3

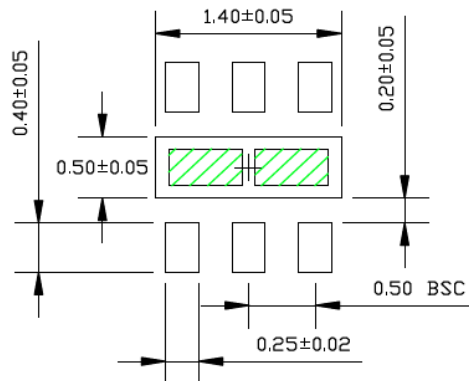

RECOMMENDED LAND PATTERN

NOTE: 4

NOTE:

1. MAX PACKAGE WARPAGE IS 0.05 MM
2. MAX ALLOWABLE BURR IS 0.076MM IN ALL DIRECTIONS
3. PIN #1 IS ON TOP WILL BE LASER MARKED
4. GREEN SHADED AREA REPRESENT SOLDER STENCIL OPENING (OPTIONAL) FOR IMPROVED THERMAL PERFORMANCE. SIZE: 0.55x0.30MM

Note: For the most current package drawings, please see the Microchip Packaging Specification located at <http://www.microchip.com/packaging>.

**Package Outlines and Dimensions**

**TITLE**

6 LEAD TDFN 2.0x1.3 mm PACKAGE OUTLINE & RECOMMENDED LAND PATTERN

<b>DRAWING #</b>	TDFN2013-6LD-PL-1	<b>UNIT</b>	MM
<b>Lead Frame</b>	NiPdAu	<b>Lead Finish</b>	NiPdAu

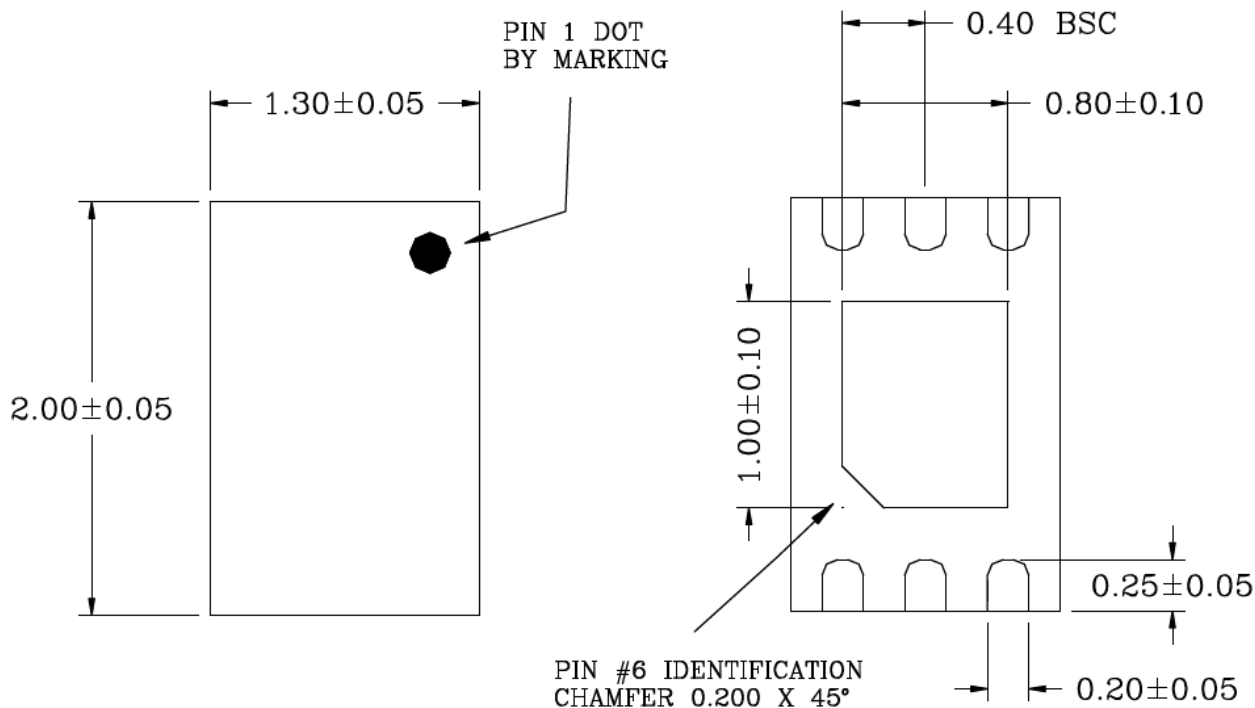

TOP VIEW

NOTE: 1, 2

BOTTOM VIEW

NOTE: 1, 2

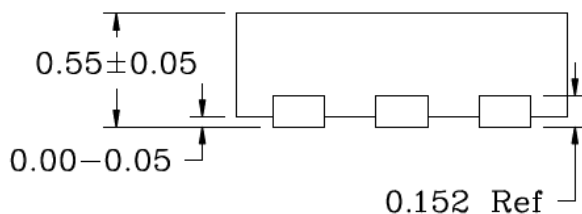

SIDE VIEW

NOTE: 1, 2

**NOTES**

1. MAX PACKAGE WARPAGE IS 0.05mm.
2. MAX ALLOWABLE BURR IS 0.076mm IN ALL DIRECTIONS.
3. PIN #1 IS ON TOP WILL BE LASER MARKED.
4. UNIT IN mm.
5. SHADED AREA IS SOLDER STENCIL OPENING.
6. RECOMMENDED VIA SIZE IS 0.30-0.35mm.

Note: For the most current package drawings, please see the Microchip Packaging Specification located at <http://www.microchip.com/packaging>.

**Package Outlines and Dimensions**

POD-Land Pattern TDFN2013-6LD-PL-1

RECOMMENDED LAND PATTERN

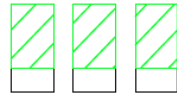
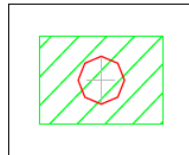
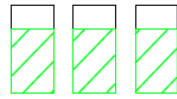

STACKED-UP

NOTE: 4, 5, 6

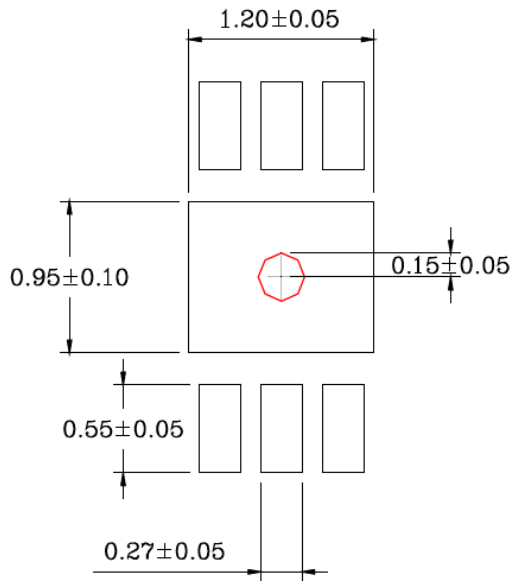

EXPOSED METAL TRACE

NOTE: 4, 6

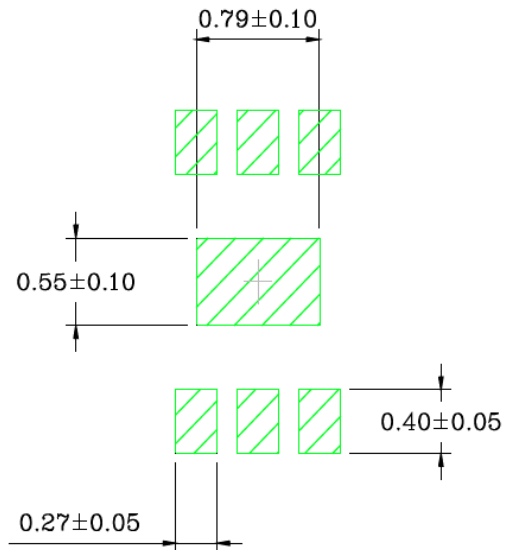

SOLDER STENCIL OPENING

NOTE: 4, 5

Note: For the most current package drawings, please see the Microchip Packaging Specification located at <http://www.microchip.com/packaging>.

## Package Outlines and Dimensions

### TITLE

10 LEAD TDFN 2.5x2.5mm PACKAGE OUTLINE & RECOMMENDED LAND PATTERN

<b>DRAWING #</b>	TDFN2525-10LD-PL-1	<b>UNIT</b>	MM
<b>Lead Frame</b>	Copper	<b>Lead Finish</b>	Matte Tin

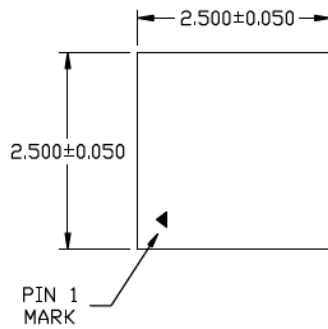

**TOP VIEW**  
NOTE: 1, 2, 3

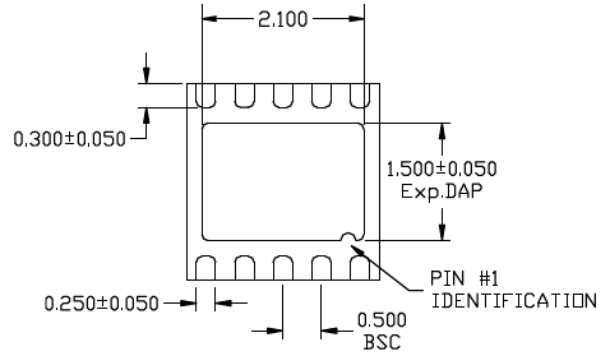

**BOTTOM VIEW**  
NOTE: 1, 2

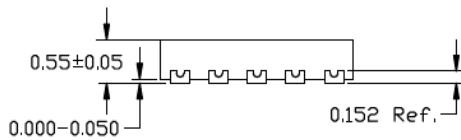

**SIDE VIEW**  
NOTE: 1, 2

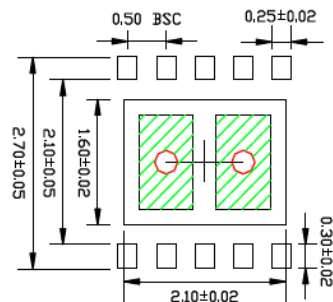

**RECOMMENDED LAND PATTERN**  
NOTE: 4

**NOTE:**

1. MAX PACKAGE WARPAGE IS 0.05MM
2. MAX ALLOWABLE BURR IS 0.076MM IN ALL DIRECTIONS
3. PIN #1 IS ON TOP WILL BE LASER MARKED
4. GREEN RECTANGLES (SHADED AREA) INDICATE STENCIL OPENING ON EXPOSED AREA. SIZE IS 0.6X0.9MM, SPACING IS 0.3MM.
5. RED CIRCLES REPRESENT THERMAL VIAS & SHOULD BE CONNECTED TO GND FOR MAX PERFORMANCE. 0.30 - 0.35 MM RECOMMENDED DIAMETER, 1.00 MM PITCH

Note: For the most current package drawings, please see the Microchip Packaging Specification located at <http://www.microchip.com/packaging>.

---



---

## Package Outlines and Dimensions

---



---

**TITLE**

12 LEAD TDFN 2.5x2.5mm PACKAGE OUTLINE &amp; RECOMMENDED LAND PATTERN

DRAWING #	TDFN2525-12LD-PL-1	UNIT	MM
-----------	--------------------	------	----

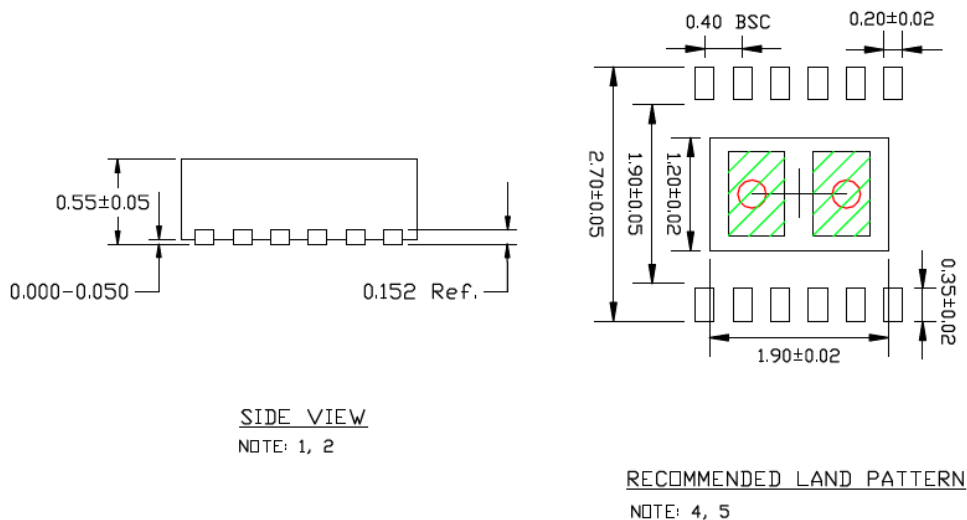
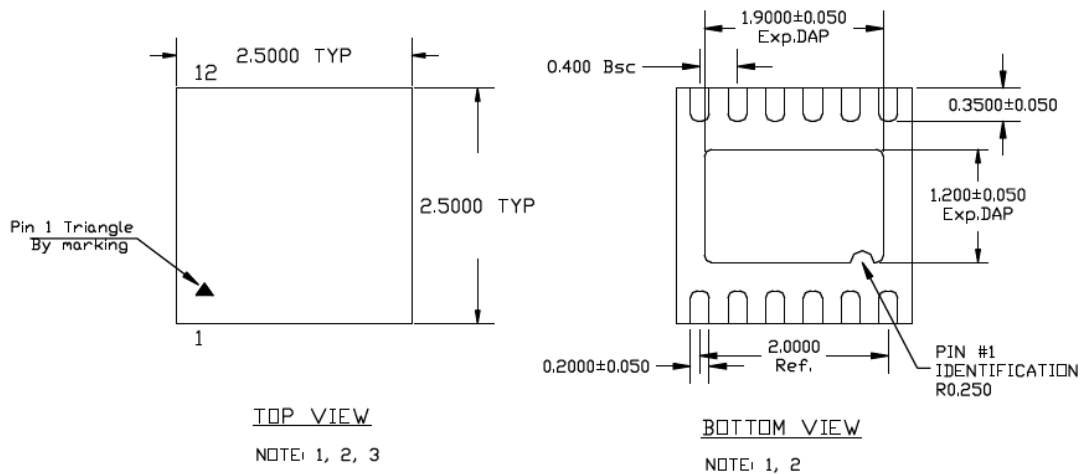
**NOTE:**

1. MAX PACKAGE WARPAGE IS 0.05MM
2. MAX ALLOWABLE BURR IS 0.076MM IN ALL DIRECTIONS
3. PIN #1 IS ON TOP WILL BE LASER MARKED
4. GREEN RECTANGLES (SHADED AREA) INDICATE STENCIL OPENING ON EXPOSED AREA. SIZE IS 0.6X0.9MM, SPACING IS 0.3MM.
5. RED CIRCLES REPRESENT THERMAL VIAS & SHOULD BE CONNECTED TO GND FOR MAX PERFORMANCE. 0.30 - 0.35 MM RECOMMENDED DIAMETER, 1.00 MM PITCH

Note: For the most current package drawings, please see the Microchip Packaging Specification located at <http://www.microchip.com/packaging>.



**MICROCHIP**

---

---

**Package Outlines and Dimensions**

---

---

**NOTES:**



---

---

**Package Outlines and Dimensions**

---

---

**TO220-TO263**

Micrel Legacy

**Package Outlines and Dimensions**

**TITLE**

3 LEAD TO220 PACKAGE OUTLINE & RECOMMENDED LAND PATTERN

<b>DRAWING #</b>	TO220-3LD-PL-1	<b>UNIT</b>	INCH
<b>Lead Frame</b>	Copper Alloy	<b>Lead Finish</b>	Matte Tin

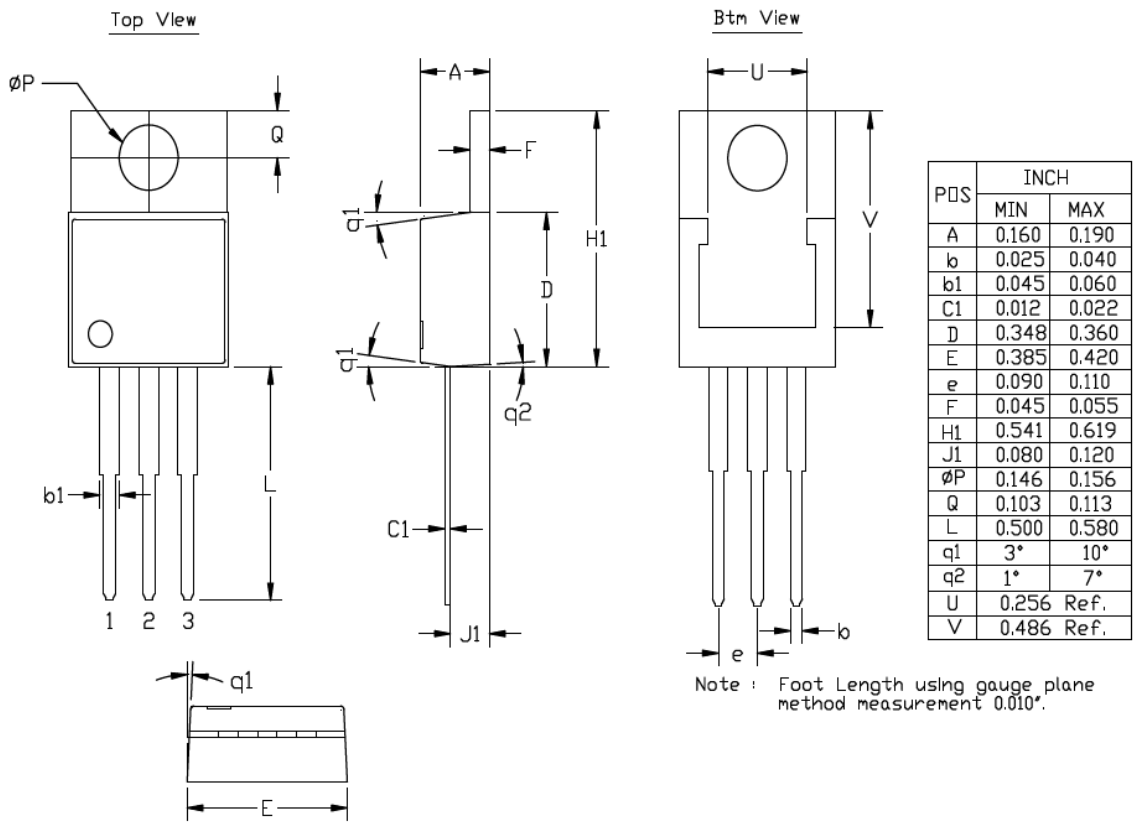

Note: For the most current package drawings, please see the Microchip Packaging Specification located at <http://www.microchip.com/packaging>.

---



---

## Package Outlines and Dimensions

---



---

**TITLE**

5 LEAD TO220 PACKAGE OUTLINE &amp; RECOMMENDED LAND PATTERN

<b>DRAWING #</b>	TO220-5LD-PL-1	<b>UNIT</b>	INCH
<b>Lead Frame</b>	Copper Alloy	<b>Lead Finish</b>	Matte Tin

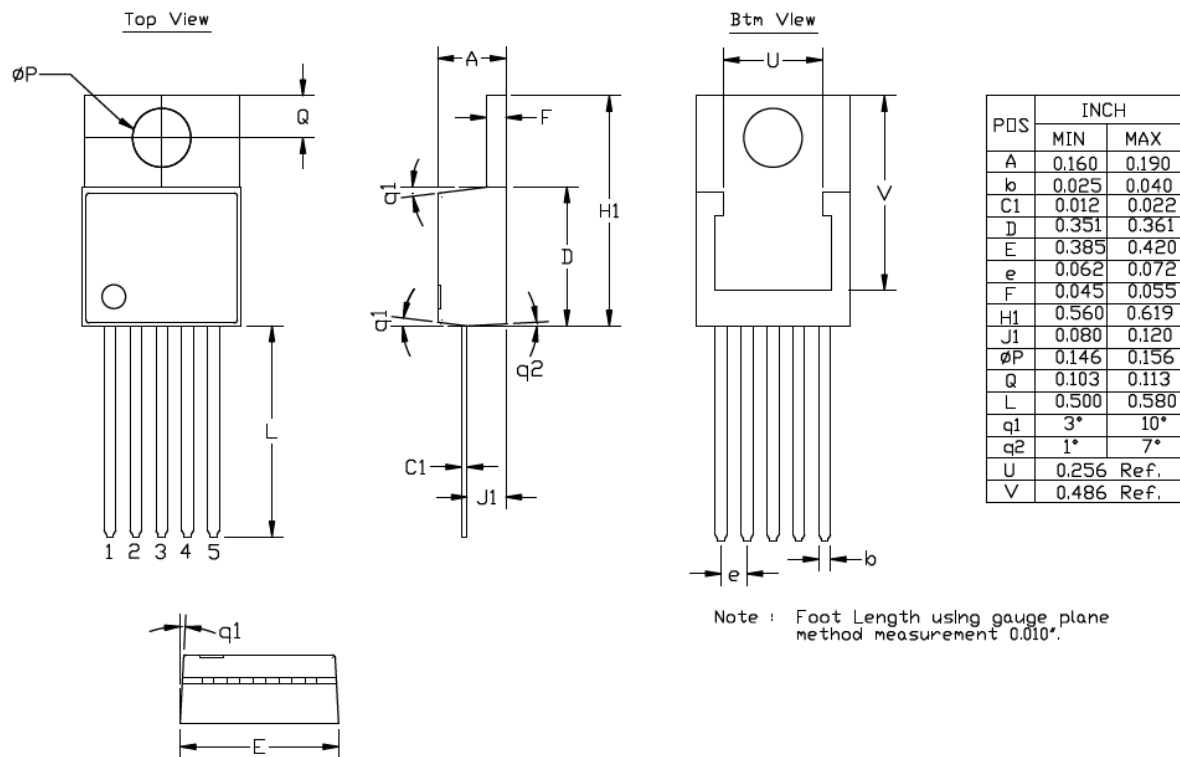

Note: For the most current package drawings, please see the Microchip Packaging Specification located at <http://www.microchip.com/packaging>.

## Package Outlines and Dimensions

### TITLE

2 and 5 LEAD TO220 (LB) PACKAGE OUTLINE & RECOMMENDED LAND PATTERN

<b>DRAWING #</b>	TO220-LB02-5LD-PL-1	<b>UNIT</b>	INCH
<b>Lead Frame</b>	Copper Alloy	<b>Lead Finish</b>	Matte Tin

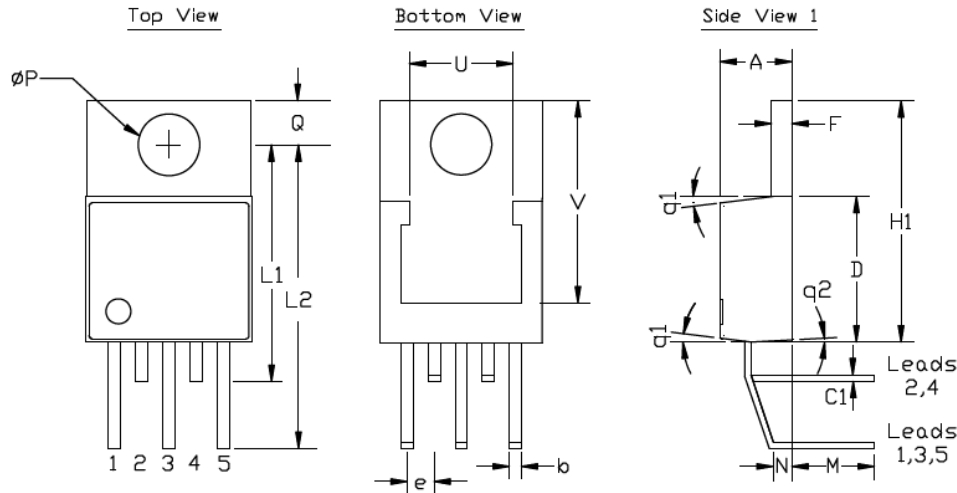

POS	INCH	
	MIN	MAX
A	0.160	0.190
b	0.025	0.040
C1	0.012	0.022
D	0.351	0.361
E	0.385	0.420
e	0.062	0.072
F	0.045	0.055
H1	0.560	0.595
L1	0.563	0.583
L2	0.725	0.745
M	0.185	0.215
N	0.010	0.080
$\phi P$	0.146	0.156
Q	0.103	0.113
q1	3°	10°
q2	1°	7°
U	0.256	Ref.
V	0.486	Ref.

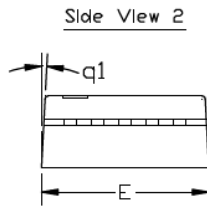

Note : Foot Length using gauge plane method measurement 0.010".

Note: For the most current package drawings, please see the Microchip Packaging Specification located at <http://www.microchip.com/packaging>.

---



---

## Package Outlines and Dimensions

---



---

**TITLE**

3 and 5 LEAD TO220 (LB) PACKAGE OUTLINE &amp; RECOMMENDED LAND PATTERN

<b>DRAWING #</b>	TO220-LB03-5LD-PL-1	<b>UNIT</b>	INCH
<b>Lead Frame</b>	Copper Alloy	<b>Lead Finish</b>	Matte Tin

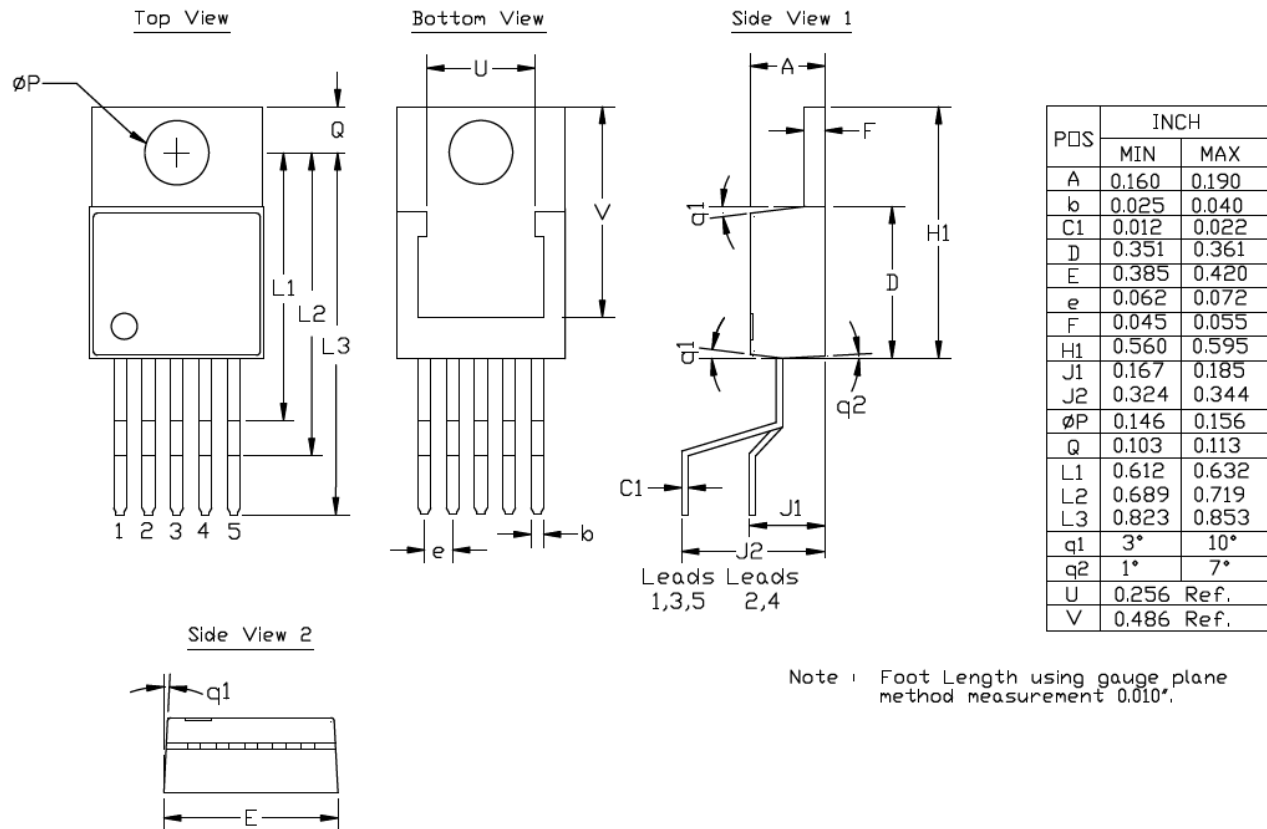

Note: For the most current package drawings, please see the Microchip Packaging Specification located at <http://www.microchip.com/packaging>.

**Package Outlines and Dimensions**

**TITLE**

3 LEAD TO247 PACKAGE OUTLINE & RECOMMENDED LAND PATTERN

<b>DRAWING #</b>	TO247-3LD-PL-1	<b>UNIT</b>	INCH/ MM
<b>Lead Frame</b>	Copper Alloy	<b>Lead Finish</b>	Matte Tin

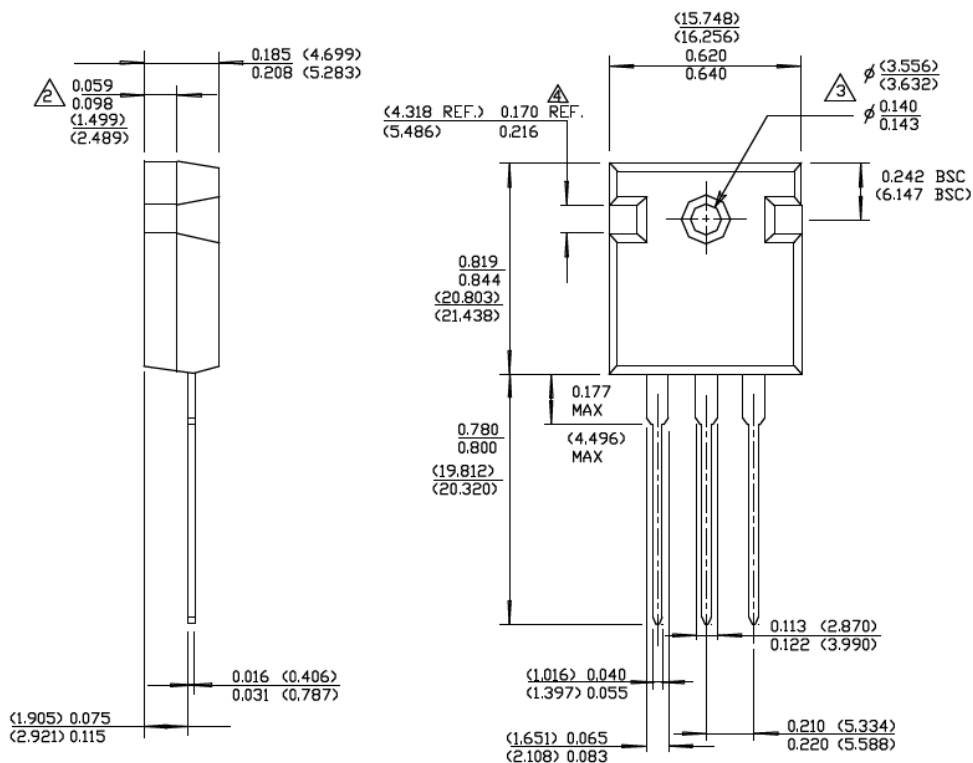

**NOTE**

1. CONTROLLED DIMENSION IS INCH. DIMENSION IN BRACKET IS MILLIMETER.
2. DIMENSIONS DO NOT INCLUDE END FLASH, MOLD FLASH, MATERIAL PROTRUSIONS.

Note: For the most current package drawings, please see the Microchip Packaging Specification located at <http://www.microchip.com/packaging>.

---



---

## Package Outlines and Dimensions

---



---

**TITLE**

5 LEAD TO247 PACKAGE OUTLINE &amp; RECOMMENDED LAND PATTERN

<b>DRAWING #</b>	TO247-5LD-PL-1	<b>UNIT</b>	INCH/ MM
<b>Lead Frame</b>	Copper Alloy	<b>Lead Finish</b>	Matte Tin

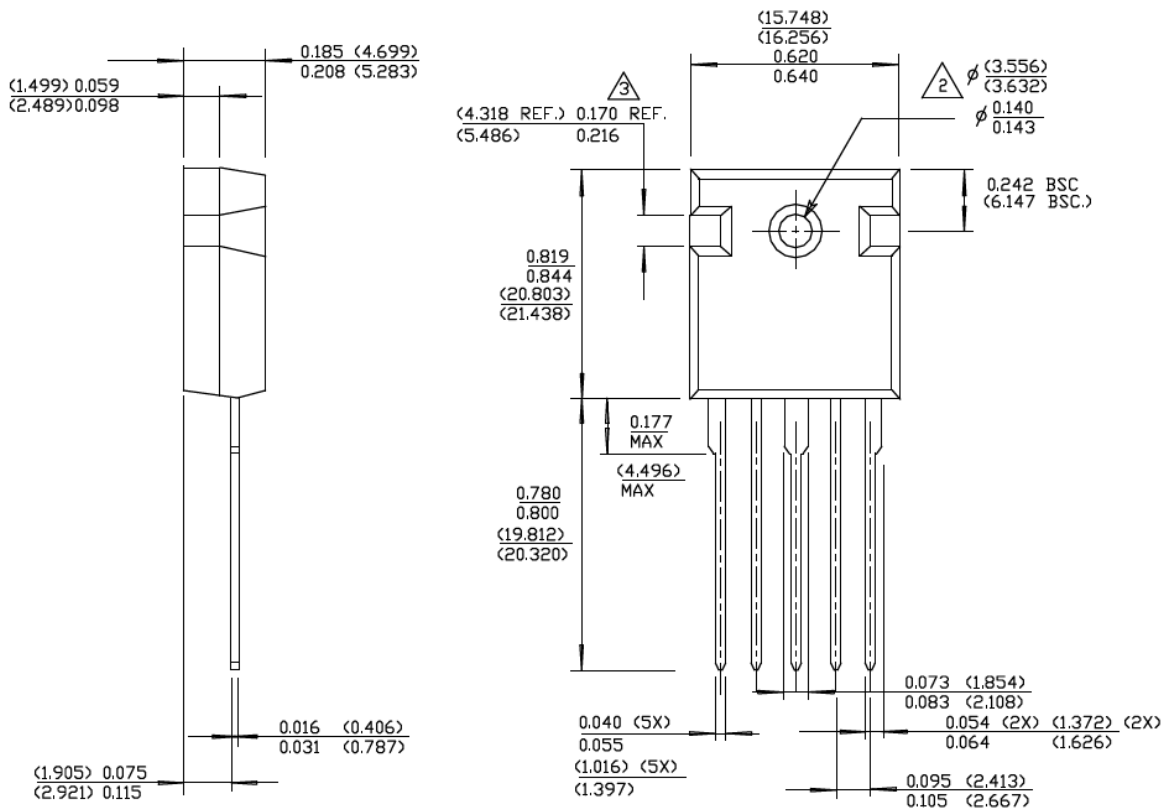
**NOTE**

1. CONTROLLED DIMENSION IS INCH. DIMENSION IN BLANKET IS MILLIMETER.
2. DIMENSIONS DO NOT INCLUDE END FLASH, MOLD FLASH, MATERIAL PROTRUSIONS.

Note: For the most current package drawings, please see the Microchip Packaging Specification located at <http://www.microchip.com/packaging>.

## Package Outlines and Dimensions

### TITLE

2 LEAD TO252 PACKAGE OUTLINE & RECOMMENDED LAND PATTERN

<b>DRAWING #</b>	TO252-2LD-PL-1	<b>UNIT</b>	INCH/ MM
<b>Lead Frame</b>	Copper Alloy	<b>Lead Finish</b>	Matte Tin

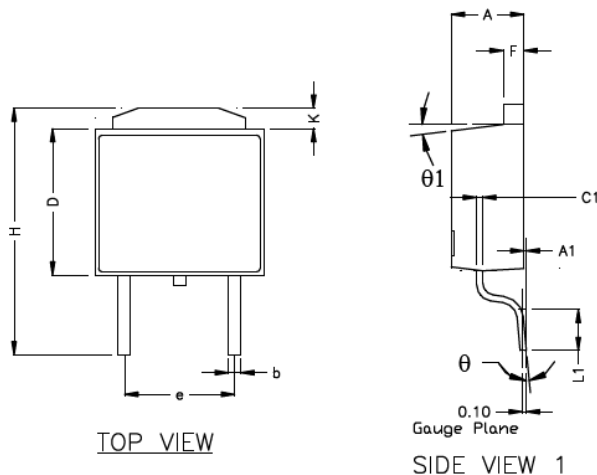

POS	INCH		MM	
	MIN	MAX	MIN	MAX
A	0.087	0.094	2.210	2.387
A1	0.000	0.012	0.000	0.305
b	0.032	0.035	0.814	0.889
C1	0.012	0.023	0.305	0.584
D	0.236	0.241	6.000	6.200
E	0.252	0.260	6.400	6.604
e	0.170	0.190	4.320	4.826
F	0.019	0.023	0.483	0.584
H	0.378	0.402	9.601	10.210
K	0.039	0.047	1.000	1.200
L1	0.055	0.065	1.397	1.651
theta	0°	8°	0°	8°
theta1	3°	10°	3°	10°
Q	0.055	0.075	1.397	1.905
U	0.206	Ref.	5.232	Ref.
V	0.213	Ref.	5.415	Ref.

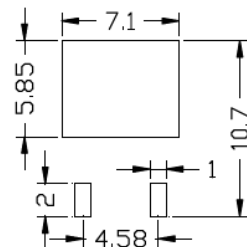
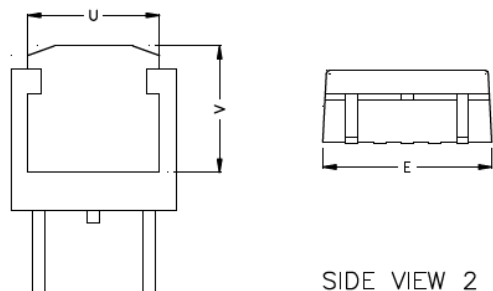

### RECOMMENDED LAND PATTERN

NOTE: unit in mm

#### NOTE:

1. PACKAGE OUTLINE EXCLUSIVE OF MOLD FLASH & METAL BURR.
2. PACKAGE OUTLINE INCLUSIVE OF PLATING THICKNESS.
3. FOOT LENGTH USING GAUGE PLANE METHOD MEASUREMENT 0.010"
4. ALL DIMENSIONS ARE IN INCHES/MILLIMETERS.

Note: For the most current package drawings, please see the Microchip Packaging Specification located at <http://www.microchip.com/packaging>.



---



---

## Package Outlines and Dimensions

---



---

**TITLE**

3 LEAD TO252 PACKAGE OUTLINE &amp; RECOMMENDED LAND PATTERN

<b>DRAWING #</b>	TO252-3LD-PL-1	<b>UNIT</b>	INCH/ MM
<b>Lead Frame</b>	Copper Alloy	<b>Lead Finish</b>	Matte Tin

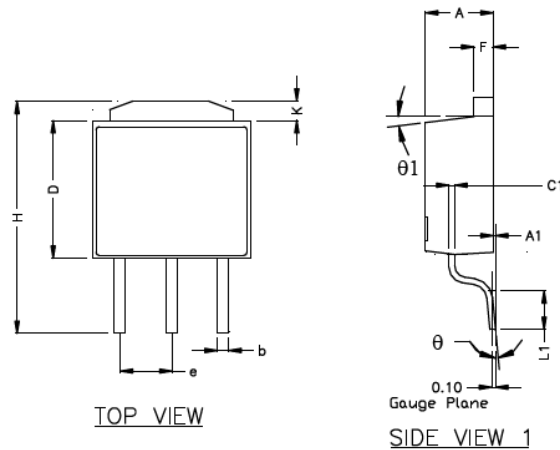

POS	INCH		MM	
	MIN	MAX	MIN	MAX
A	0.087	0.094	2.210	2.387
A1	0.000	0.012	0.000	0.305
b	0.032	0.035	0.814	0.889
C1	0.012	0.023	0.305	0.584
D	0.236	0.241	6.000	6.200
E	0.252	0.260	6.400	6.604
e	0.085	0.095	2.160	2.413
F	0.019	0.023	0.483	0.584
H	0.378	0.402	9.601	10.210
K	0.039	0.047	1.000	1.200
L1	0.055	0.065	1.397	1.651
theta	0°	8°	0°	8°
theta1	3°	10°	3°	10°
Q	0.055	0.075	1.397	1.905
U	0.206	Ref.	5.232	Ref.
V	0.213	Ref.	5.415	Ref.

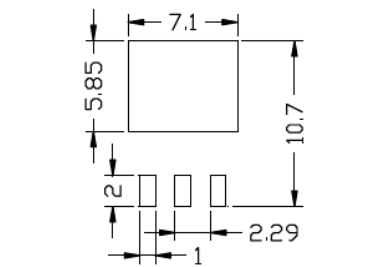
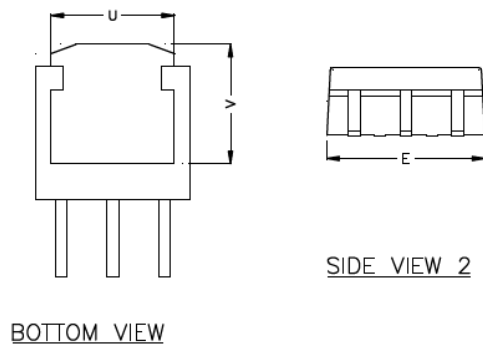
**RECOMMENDED LAND PATTERN**

NOTE: unit in mm

- NOTE:
1. PACKAGE OUTLINE EXCLUSIVE OF MOLD FLASH & METAL BURR.
  2. PACKAGE OUTLINE INCLUSIVE OF PLATING THICKNESS.
  3. FOOT LENGTH USING GAUGE PLANE METHOD MEASUREMENT 0.010"
  4. ALL DIMENSIONS ARE IN INCHES/MILLIMETERS.

Note: For the most current package drawings, please see the Microchip Packaging Specification located at <http://www.microchip.com/packaging>.

## Package Outlines and Dimensions

### TITLE

5 LEAD TO252 PACKAGE OUTLINE & RECOMMENDED LAND PATTERN

<b>DRAWING #</b>	TO252-5LD-PL-1	<b>UNIT</b>	INCH/ MM
<b>Lead Frame</b>	Copper Alloy	<b>Lead Finish</b>	Matte Tin

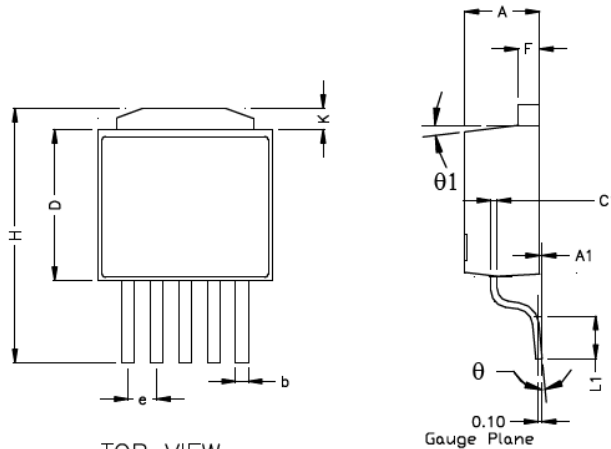

TOP VIEW

SIDE VIEW 1

POS	INCH		MM	
	MIN	MAX	MIN	MAX
A	0.087	0.094	2.210	2.387
A1	0.000	0.012	0.000	0.305
b	0.023	0.026	0.584	0.660
C1	0.012	0.023	0.305	0.584
D	0.236	0.241	6.000	6.200
E	0.252	0.260	6.400	6.604
e	0.045	0.055	1.143	1.397
F	0.019	0.023	0.483	0.584
H	0.378	0.402	9.601	10.210
K	0.039	0.047	1.000	1.200
L1	0.055	0.065	1.397	1.651
θ	0°	8°	0°	8°
θ1	3°	10°	3°	10°
Q	0.055	0.075	1.397	1.905
U	0.206	Ref.	5.232	Ref.
V	0.213	Ref.	5.415	Ref.

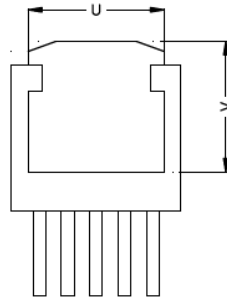

BOTTOM VIEW

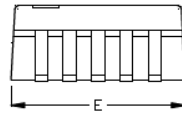

SIDE VIEW 2

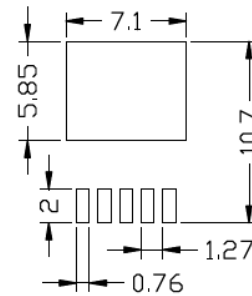

RECOMMENDED LAND PATTERN

NOTE: unit in mm

- NOTE:
1. PACKAGE OUTLINE EXCLUSIVE OF MOLD FLASH & METAL BURR.
  2. PACKAGE OUTLINE INCLUSIVE OF PLATING THICKNESS.
  3. FOOT LENGTH USING GAUGE PLANE METHOD MEASUREMENT 0.010"
  4. ALL DIMENSIONS ARE IN INCHES/MILLIMETERS.

Note: For the most current package drawings, please see the Microchip Packaging Specification located at <http://www.microchip.com/packaging>.

---



---

## Package Outlines and Dimensions

---



---

**TITLE**

3 LEAD TO263 PACKAGE OUTLINE &amp; RECOMMENDED LAND PATTERN

<b>DRAWING #</b>	TO263-3LD-PL-1	<b>UNIT</b>	INCH/MM
------------------	----------------	-------------	---------

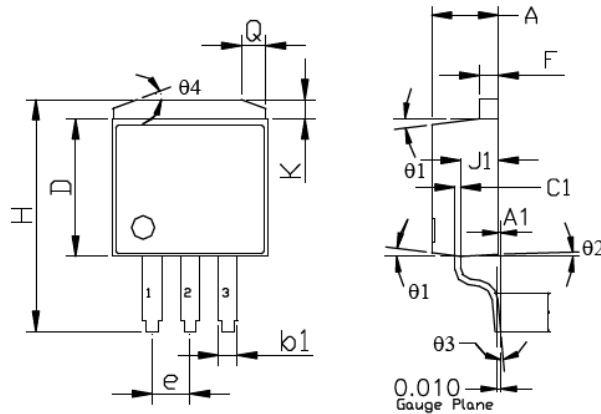

TOP VIEW

SIDE VIEW 1

POS	INCH		MM	
	MIN	MAX	MIN	MAX
A	0.170	0.181	4.318	4.597
A1	0.000	0.012	0.000	0.305
b1	0.047	0.053	1.194	1.346
C1	0.012	0.023	0.305	0.584
D	0.330	0.361	8.382	9.169
E	0.396	0.420	10.058	10.668
e	0.095	0.105	2.413	2.667
F	0.045	0.055	1.143	1.397
H	0.575	0.625	14.605	15.875
J1	0.080	0.120	2.032	3.048
L1	0.090	0.110	2.286	2.794
K	0.045	0.066	1.143	1.676
theta1	3°	10°	3°	10°
theta2	1°	7°	1°	7°
theta3	0°	8°	0°	8°
theta4	18°	22°	18°	22°
Q	0.055	0.075	1.397	1.905
U	0.256	Ref.	6.502	Ref.
V	0.303	Ref.	7.696	Ref.

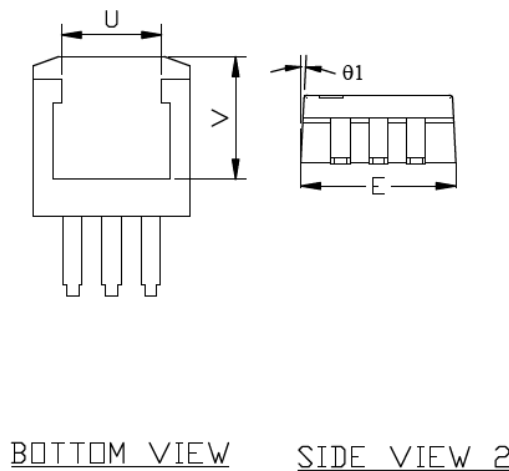

BOTTOM VIEW

SIDE VIEW 2

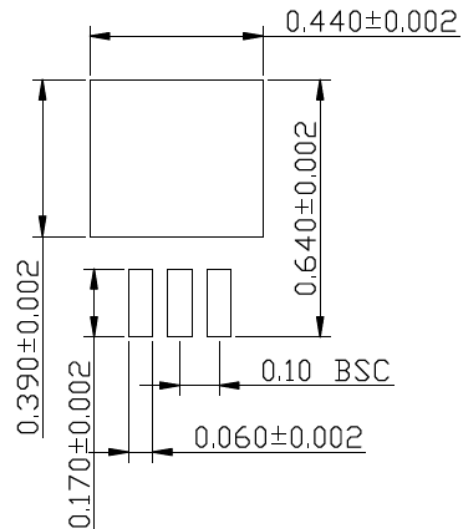
 RECOMMENDED LAND  
 PATTERN (UNIT: INCH)

**NOTES:**

FOOT LENGTH USE GAUGE PLANE METHOD MEASUREMENT 0.010"

 Note: For the most current package drawings, please see the Microchip Packaging Specification located at <http://www.microchip.com/packaging>.

## Package Outlines and Dimensions

### TITLE

5 LEAD T0263 PACKAGE OUTLINE & RECOMMENDED LAND PATTERN

<b>DRAWING #</b>	T0263-5LD-PL-1	<b>UNIT</b>	INCH/MM
------------------	----------------	-------------	---------

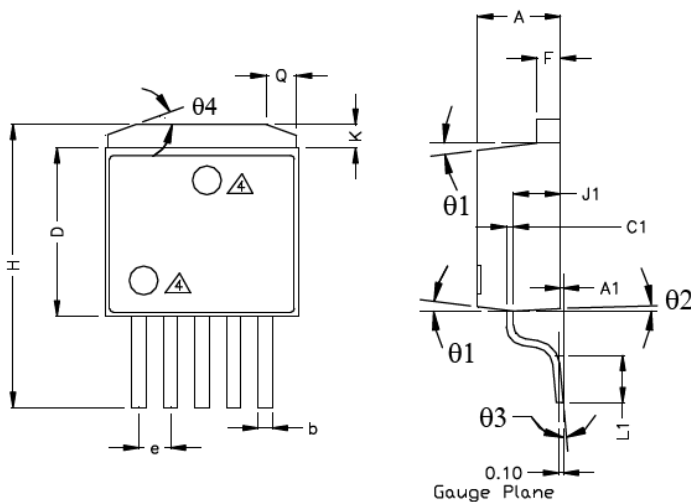

TOP VIEW

SIDE VIEW 1

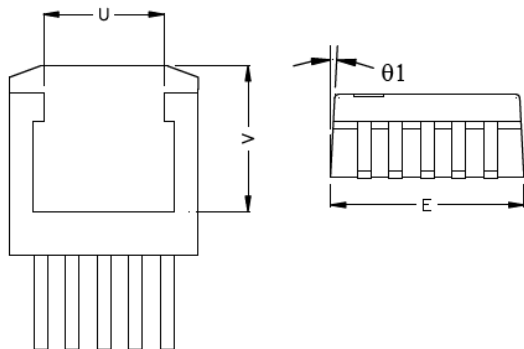

BOTTOM VIEW

SIDE VIEW 2

POS	INCH		MM	
	MIN	MAX	MIN	MAX
A	0.170	0.181	4.318	4.597
A1	0.000	0.012	0.000	0.305
b	0.026	0.036	0.660	0.914
C1	0.012	0.023	0.305	0.584
D	0.330	0.361	8.392	9.169
E	0.396	0.420	10.058	10.668
e	0.062	0.072	1.575	1.829
F	0.045	0.055	1.143	1.397
H	0.575	0.625	14.605	15.875
J1	0.080	0.120	2.032	3.048
K	0.045	0.066	1.143	1.676
L1	0.090	0.110	2.286	2.794
theta 1	3°	10°	3°	10°
theta 2	1°	7°	1°	7°
theta 3	0°	8°	0°	8°
theta 4	18°	22°	18°	22°
Q	0.055	0.075	1.397	1.905
U	0.256	Ref.	6.502	Ref.
V	0.305	Ref.	7.747	Ref.

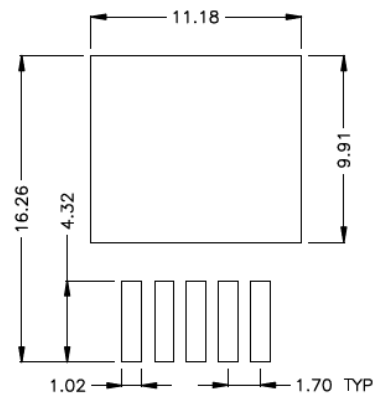

RECOMMENDED LAND PATTERN  
(UNIT : mm)

**NOTE:**

1. PACKAGE OUTLINE EXCLUSIVE OF MOLD FLASH & METAL BURR.
2. PACKAGE OUTLINE INCLUSIVE OF PLATING THICKNESS.
3. FOOT LENGTH USING GAUGE PLANE METHOD MEASUREMENT 0.010"
4.  PACKAGE TOP MARK MAY BE IN TOP CENTER OR LOWER LEFT CORNER
5. ALL DIMENSIONS ARE IN INCHES/MILLIMETERS.

Note: For the most current package drawings, please see the Microchip Packaging Specification located at <http://www.microchip.com/packaging>.

---



---

## Package Outlines and Dimensions

---



---

**TITLE**

7 LEAD T0263 PACKAGE OUTLINE &amp; RECOMMENDED LAND PATTERN

<b>DRAWING #</b>	T0263-7LD-PL-1	<b>UNIT</b>	INCH/MM
------------------	----------------	-------------	---------

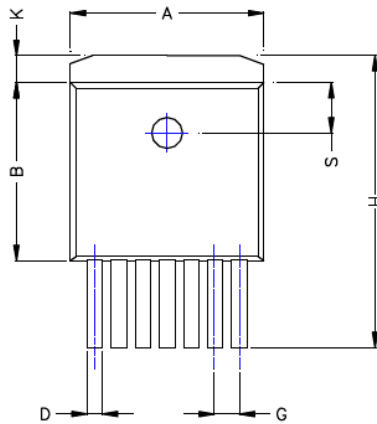

TOP VIEW

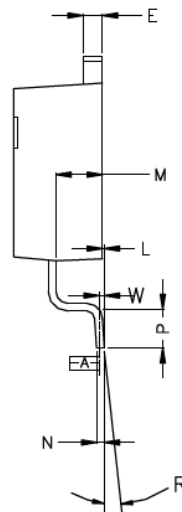

SIDE VIEW 1

POS	INCHES		MILLIMETERS	
	MIN	MAX	MIN	MAX
A	.396	.406	10.05	10.31
B	.330	.340	8.38	8.64
C	.170	.180	4.31	4.57
D	.026	.036	0.66	0.91
E	.045	.055	1.14	1.40
G	.050 ref		1.27 ref	
H	.580	.620	14.73	15.75
K	.055	.066	1.40	1.68
L	.000	.010	0.00	0.25
M	.098	.108	2.49	2.74
N	.017	.023	0.43	0.58
P	.090	.110	2.29	2.79
R	0°	8°	0°	8°
S	.095	.105	2.41	2.67
U	.30 ref		7.62 ref	
V	.305 ref		7.75 ref	
W	.010		0.25	

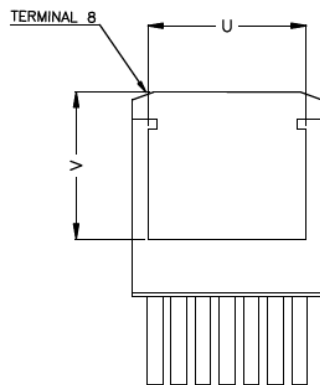

BOTTOM VIEW

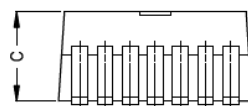

SIDE VIEW 2

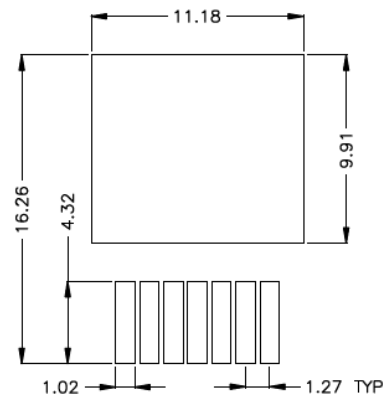
 RECOMMENDED LAND PATTERN  
(UNIT : mm)

- NOTE:
1. PACKAGE OUTLINE EXCLUSIVE OF MOLD FLASH & METAL BURR.
  2. PACKAGE OUTLINE INCLUSIVE OF PLATING THICKNESS.
  3. FOOT LENGTH USING GAUGE PLANE METHOD MEASUREMENT 0.010"
  4. ALL DIMENSIONS ARE IN INCHES/MILLIMETERS.

Note: For the most current package drawings, please see the Microchip Packaging Specification located at <http://www.microchip.com/packaging>.



**MICROCHIP**

---

---

**Package Outlines and Dimensions**

---

---

NOTES:

---

---

**Package Outlines and Dimensions**

---

---

**TQFN**

Micrel Legacy

## Package Outlines and Dimensions

### TITLE

8 LEAD TQFN 1.2x1.2mm PACKAGE OUTLINE & RECOMMENDED LAND PATTERN

DRAWING #	TQFN1212-8LD-PL-1	UNIT	MM
-----------	-------------------	------	----

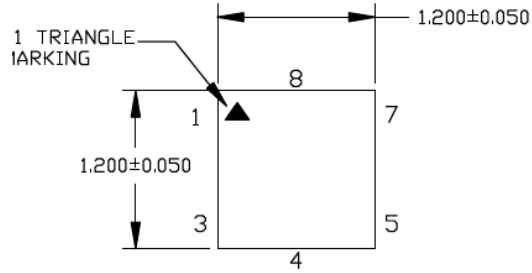

TOP VIEW

NOTE: 1, 2, 3

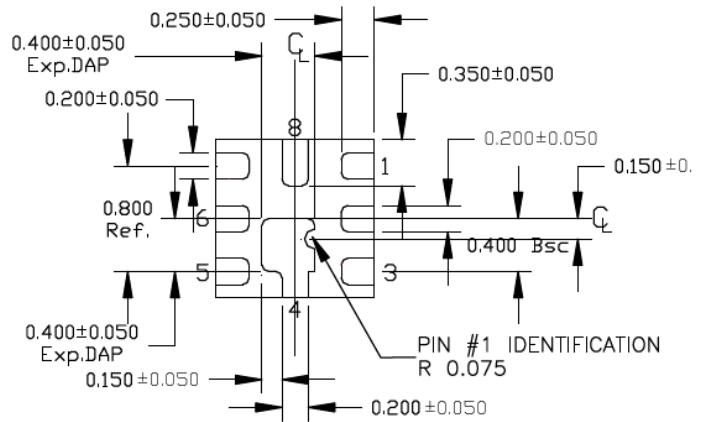

BOTTOM VIEW

NOTE: 1, 2

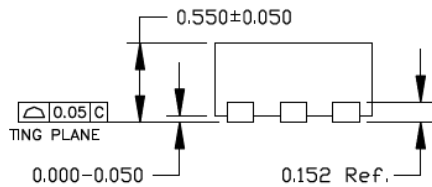

SIDE VIEW

NOTE: 1, 2

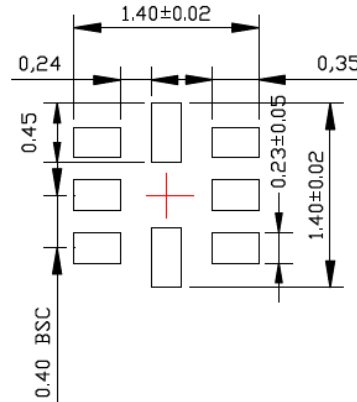

RECOMMENDED LAND PATTERN

### NOTE:

1. MAX PACKAGE WARPAGE IS 0.05MM
2. MAX ALLOWABLE BURR IS 0.076MM IN ALL DIRECTIONS
3. PIN #1 IS ON TOP WILL BE LASER MARKED

Note: For the most current package drawings, please see the Microchip Packaging Specification located at <http://www.microchip.com/packaging>.



---



---

## Package Outlines and Dimensions

---



---

**TITLE**

12 LEAD TQFN 1.60x1.60mm PACKAGE OUTLINE &amp; RECOMMENDED LAND PATTERN

<b>DRAWING #</b>	TQFN1616-12LD-PL-1	<b>UNIT</b>	MM
------------------	--------------------	-------------	----

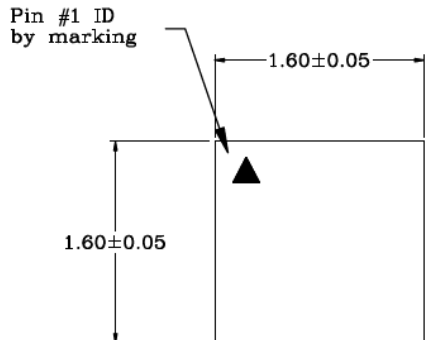

TOP VIEW

NOTE: 1,2,3

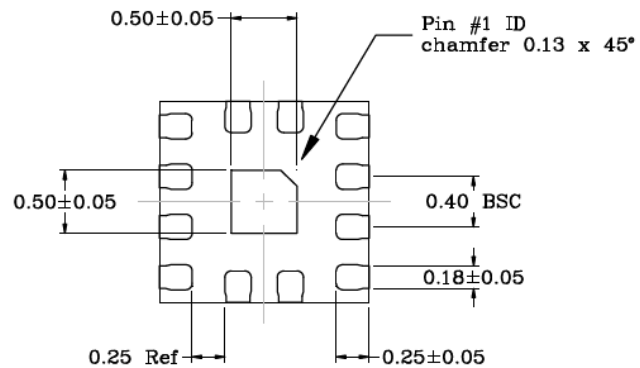

BOTTOM VIEW

NOTE: 2,3

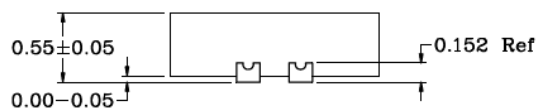

SIDE VIEW

NOTE: 2,3

**NOTES:**

1. Top mark Pin #1 will be laser mark.
2. 0.05mm max package warpage.
3. Max allowable burr is 0.076mm in all directions.
4. Red color circle is thermal via. 0.30-0.35mm in diameter. Should be connected to GND for maximum performance.
5. Shaded rectangles (area) represents solder stencil opening on exposed metal trace.
6. Green color pads represent same IO and are connected together.
7. Black color pads represent different IOs. Do not connect together.
8. Recommended Land Pattern Tolerance is  $\pm 0.020$ mm unless specified.
9. See recommended Land Pattern on page2.

Note: For the most current package drawings, please see the Microchip Packaging Specification located at <http://www.microchip.com/packaging>.

**Package Outlines and Dimensions**

POD-Land Pattern Doc #: TQFN1616-12LD-PL-1-A

**Recommended Land Pattern**

Note: 4,5,6,7,8

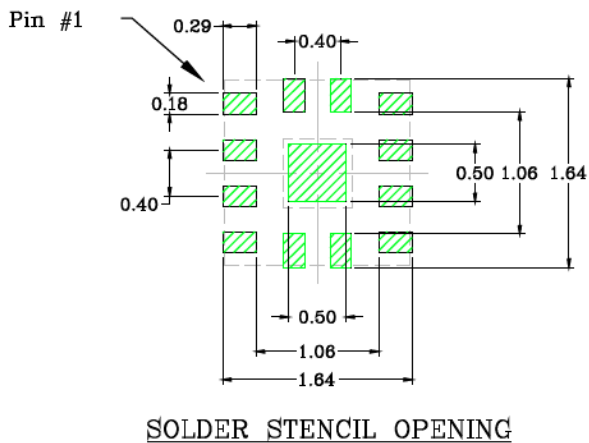
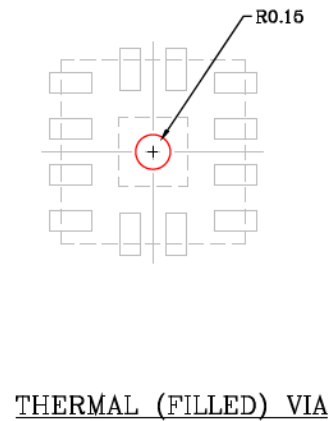
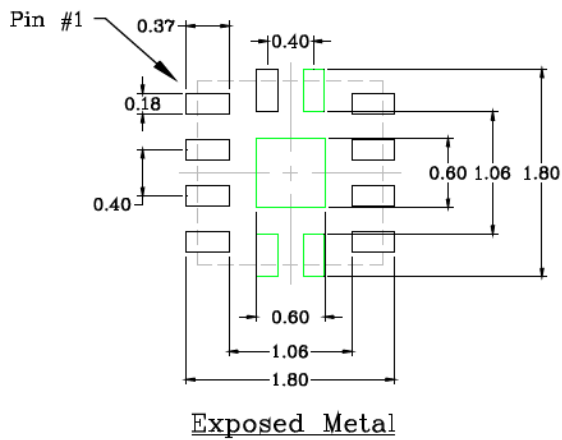
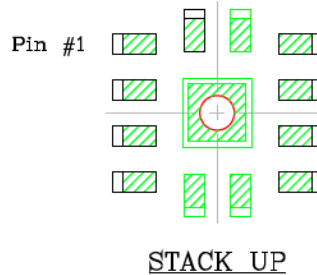

Note: For the most current package drawings, please see the Microchip Packaging Specification located at <http://www.microchip.com/packaging>.

---



---

## Package Outlines and Dimensions

---



---

**TITLE**

14 LEAD TQFN 2.5x2.5mm PACKAGE OUTLINE &amp; RECOMMENDED LAND PATTERN

DRAWING #	TQFN2525-14LD-PL-1	UNIT	MM
-----------	--------------------	------	----

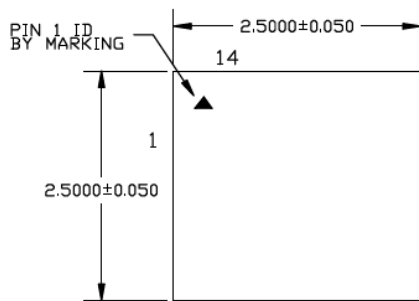
TOP VIEW

NOTE: 1, 2, 3

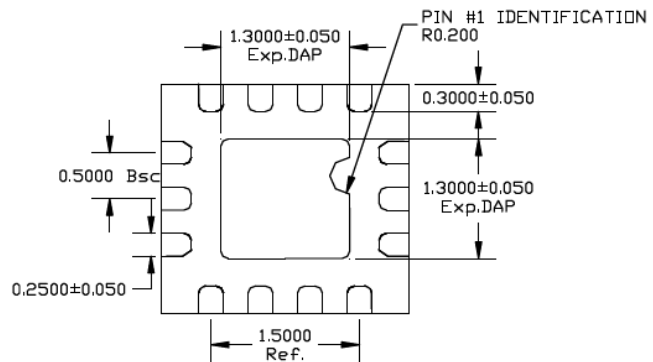
BOTTOM VIEW

NOTE: 1, 2, 3

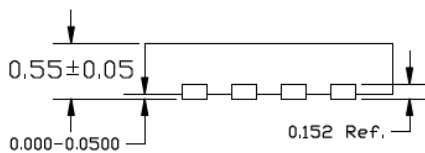
SIDE VIEW

NOTE: 1, 2, 3

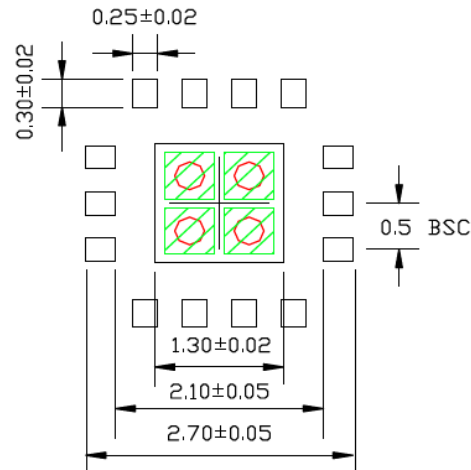
RECOMMENDED LAND PATTERN

NOTE: 4, 5

**NOTE:**

1. MAX PACKAGE WARPAGE IS 0.05 MM
2. MAX ALLOWABLE BURR IS 0.076MM IN ALL DIRECTIONS
3. PIN #1 IS ON TOP WILL BE LASER MARKED
4. RED CIRCLE IN LAND PATTERN INDICATE THERMAL VIA. SIZE SHOULD BE 0.30-0.3MM IN DIAMETER AND SHOULD BE CONNECTED TO GND FOR MAX THERMAL PERFORMANCE
5. GREEN RECTANGLES (SHADED AREA) REPRESENT OPTIONAL SOLDER STENCIL OPENING ON EXPOSED PAD AREA. RECOMMENDED SIZE IS 0.50x0.50 MM, 0.10 MM SPACING.

Note: For the most current package drawings, please see the Microchip Packaging Specification located at <http://www.microchip.com/packaging>.

## Package Outlines and Dimensions

### TITLE

16 LEAD TQFN 2.5x2.5mm PACKAGE OUTLINE & RECOMMENDED LAND PATTERN

DRAWING #	TQFN2525-16LD-PL-1	UNIT	MM
-----------	--------------------	------	----

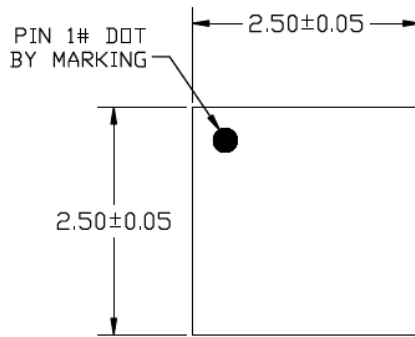

TOP VIEW

NOTE: 1, 2, 3

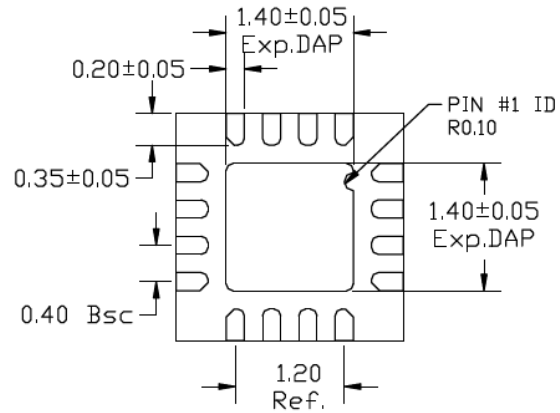

BOTTOM VIEW

NOTE: 1, 2

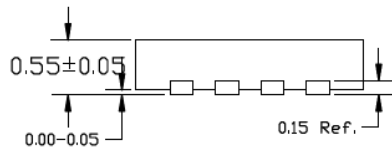

SIDE VIEW

NOTE: 1, 2

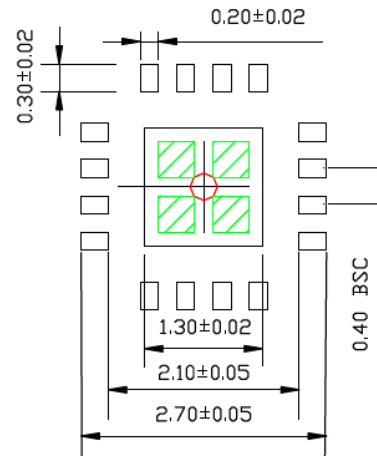

RECOMMENDED LAND PATTERN

NOTE: 4, 5

#### NOTE:

1. MAX PACKAGE WARPAGE IS 0.05MM
2. MAX ALLOWABLE BURR IS 0.076MM IN ALL DIRECTIONS
3. PIN #1 IS ON TOP WILL BE LASER MARKED
4. GREEN RECTANGLES (SHADED AREA) INDICATE STENCIL OPENING ON EXPOSED AREA. SIZE IS 0.4X0.4MM, SPACING IS 0.2MM.
5. RED CIRCLES REPRESENT THERMAL VIAS & SHOULD BE CONNECTED TO GND FOR MAX PERFORMANCE. 0.30 - 0.35 MM RECOMMENDED DIAMETER

Note: For the most current package drawings, please see the Microchip Packaging Specification located at <http://www.microchip.com/packaging>.

---

---

**Package Outlines and Dimensions**

---

---

**TQFP**

Micrel Legacy

## Package Outlines and Dimensions

### TITLE

32 LEAD TQFP 7X7 mm PACKAGE OUTLINE & RECOMMENDED LAND PATTERN

DRAWING #	TQFP7X7-32LD-PL-1	UNIT	MM [INCH]
-----------	-------------------	------	-----------

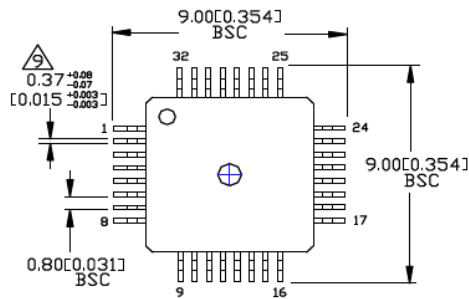

TOP VIEW

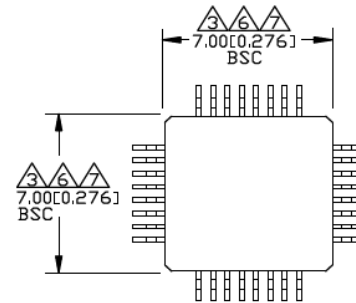

BOTTOM VIEW

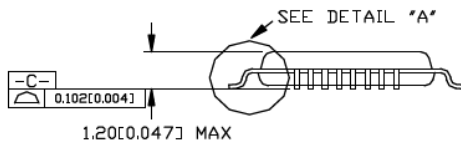

SIDE VIEW

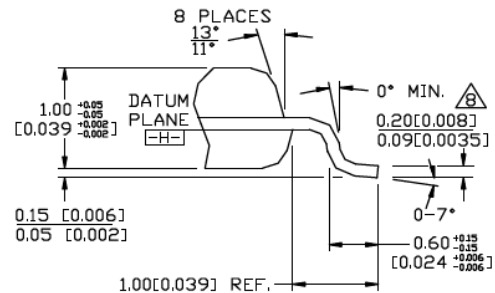

DETAIL "A"

#### NOTES:

1. DIMENSIONS ARE IN MM[INCHES].
2. CONTROLLING DIMENSION: MM.
3. DIMENSION DOES NOT INCLUDE MOLD FLASH OR PROTRUSIONS, EITHER OF WHICH SHALL NOT EXCEED 0.254 [0.010].
4. LEAD DIMENSION DOES NOT INCLUDE DAMBAR PROTRUSION.
5. MAXIMUM AND MINIMUM SPECIFICATIONS ARE INDICATED AS FOLLOWS: MAX/MIN.
6. THESE DIMENSIONS TO BE DETERMINED AT DATUM PLANE [H].
7. PACKAGE TOP DIMENSIONS ARE SMALLER THAN BOTTOM DIMENSIONS AND TOP OF PACKAGE WILL NOT OVERHANG BOTTOM OF PACKAGE.
8. DIMENSION INCLUDES LEAD FINISH.

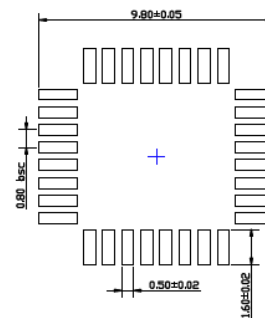

RECOMMENDED LAND PATTERN

Note: For the most current package drawings, please see the Microchip Packaging Specification located at <http://www.microchip.com/packaging>.

## Package Outlines and Dimensions

**TITLE**

32 LEAD TQFP 7X7 mm EPAD PACKAGE OUTLINE & RECOMMENDED LAND PATTERN

DRAWING #	TQFP7X7-32LD-PL-1	UNIT	MM [INCH]
-----------	-------------------	------	-----------

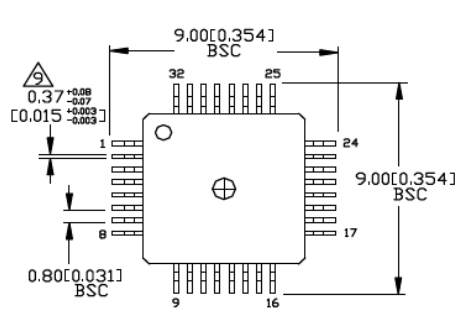

TOP VIEW

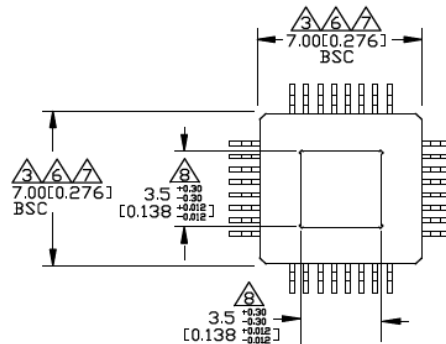

BOTTOM VIEW

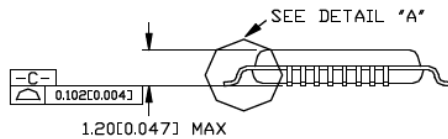

SIDE VIEW

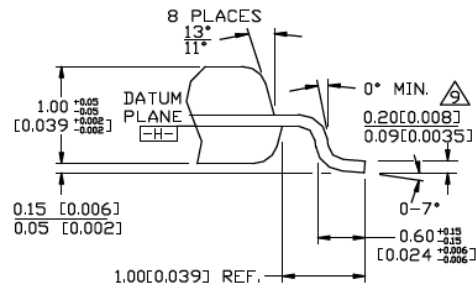

DETAIL "A"

- NOTES:**
1. DIMENSIONS ARE IN MM(INCHES).
  2. CONTROLLING DIMENSION: MM.
  3. DIMENSION DOES NOT INCLUDE MOLD FLASH OR PROTRUSIONS, EITHER OF WHICH SHALL NOT EXCEED 0.254 [0.010].
  4. LEAD DIMENSION DOES NOT INCLUDE DAMBAR PROTRUSION.
  5. MAXIMUM AND MINIMUM SPECIFICATIONS ARE INDICATED AS FOLLOWS: MAX/MIN.
  6. THESE DIMENSIONS TO BE DETERMINED AT DATUM PLANE  $\square\square$
  7. PACKAGE TOP DIMENSIONS ARE SMALLER THAN BOTTOM DIMENSIONS AND TOP OF PACKAGE WILL NOT OVERHANG BOTTOM OF PACKAGE.
  8. EXPOSED PAD SHALL BE COPLANAR WITH PACKAGE BOTTOM WITHIN 0.05mm
  9. EXPOSED PAD: Cu WITH Sn/Pb PLATING
  10. DIMENSION INCLUDES LEAD FINISH.
  10. RED CIRCLES IN LAND PATTERN REPRESENT THERMAL VIAS. RECOMMENDED SIZE IS 0.30MM DIAMETER, CONNECT TO GND

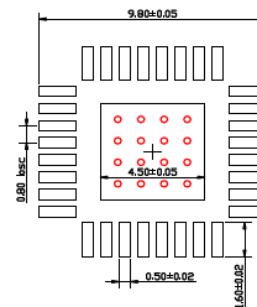

RECOMMENDED LAND PATTERN

Note: For the most current package drawings, please see the Microchip Packaging Specification located at <http://www.microchip.com/packaging>.

## Package Outlines and Dimensions

### TITLE

32 LEAD TQFP 7X7 mm EPAD PACKAGE OUTLINE & RECOMMENDED LAND PATTERN

<b>DRAWING #</b>	TQFP7X7-32LD-PL-2	<b>UNIT</b>	MM [INCH]
<b>Lead Frame</b>	Copper	<b>Lead Finish</b>	Matte Tin

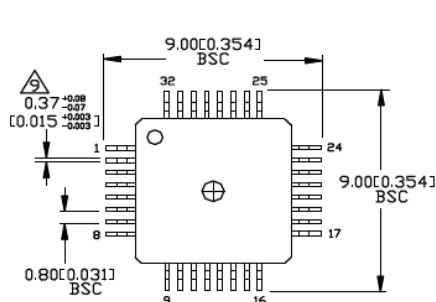

TOP VIEW

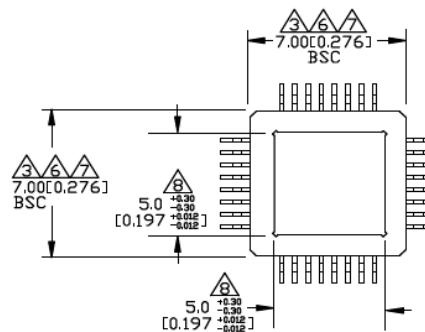

BOTTOM VIEW

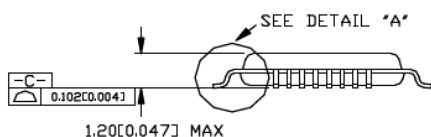

SIDE VIEW

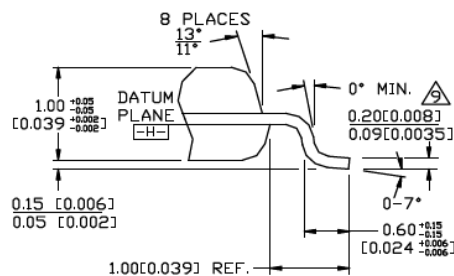

DETAIL "A"

### NOTES:

1. DIMENSIONS ARE IN MM[INCHES].
2. CONTROLLING DIMENSION: MM.
3. DIMENSION DOES NOT INCLUDE MOLD FLASH OR PROTRUSIONS, EITHER OF WHICH SHALL NOT EXCEED 0.254 [0.010].
4. LEAD DIMENSION DOES NOT INCLUDE DAMBAR PROTRUSION.
5. MAXIMUM AND MINIMUM SPECIFICATIONS ARE INDICATED AS FOLLOWS: MAX/MIN.
6. THESE DIMENSIONS TO BE DETERMINED AT DATUM PLANE [H].
7. PACKAGE TOP DIMENSIONS ARE SMALLER THAN BOTTOM DIMENSIONS AND TOP OF PACKAGE WILL NOT OVERHANG BOTTOM OF PACKAGE.
8. EXPOSED PAD SHALL BE COPLANAR WITH PACKAGE BOTTOM WITHIN 0.05mm.
9. EXPOSED PAD: Cu WITH Sn/Pb PLATING. DIMENSION INCLUDES LEAD FINISH.
10. RED CIRCLES IN LAND PATTERN REPRESENT THERMAL VIAS. RECOMMENDED SIZE IS 0.30MM DIAMETER, CONNECT TO GND.

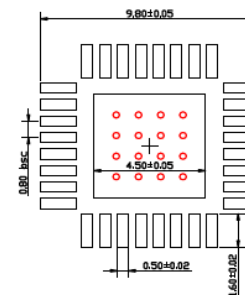

RECOMMENDED LAND PATTERN

Note: For the most current package drawings, please see the Microchip Packaging Specification located at <http://www.microchip.com/packaging>.



**Package Outlines and Dimensions**

**TITLE**

48 LEAD TQFP 7x7mm PACKAGE OUTLINE & RECOMMENDED LAND PATTERN

<b>DRAWING #</b>	TQFP7x7-48LD-PL-1	<b>UNIT</b>	MM
------------------	-------------------	-------------	----

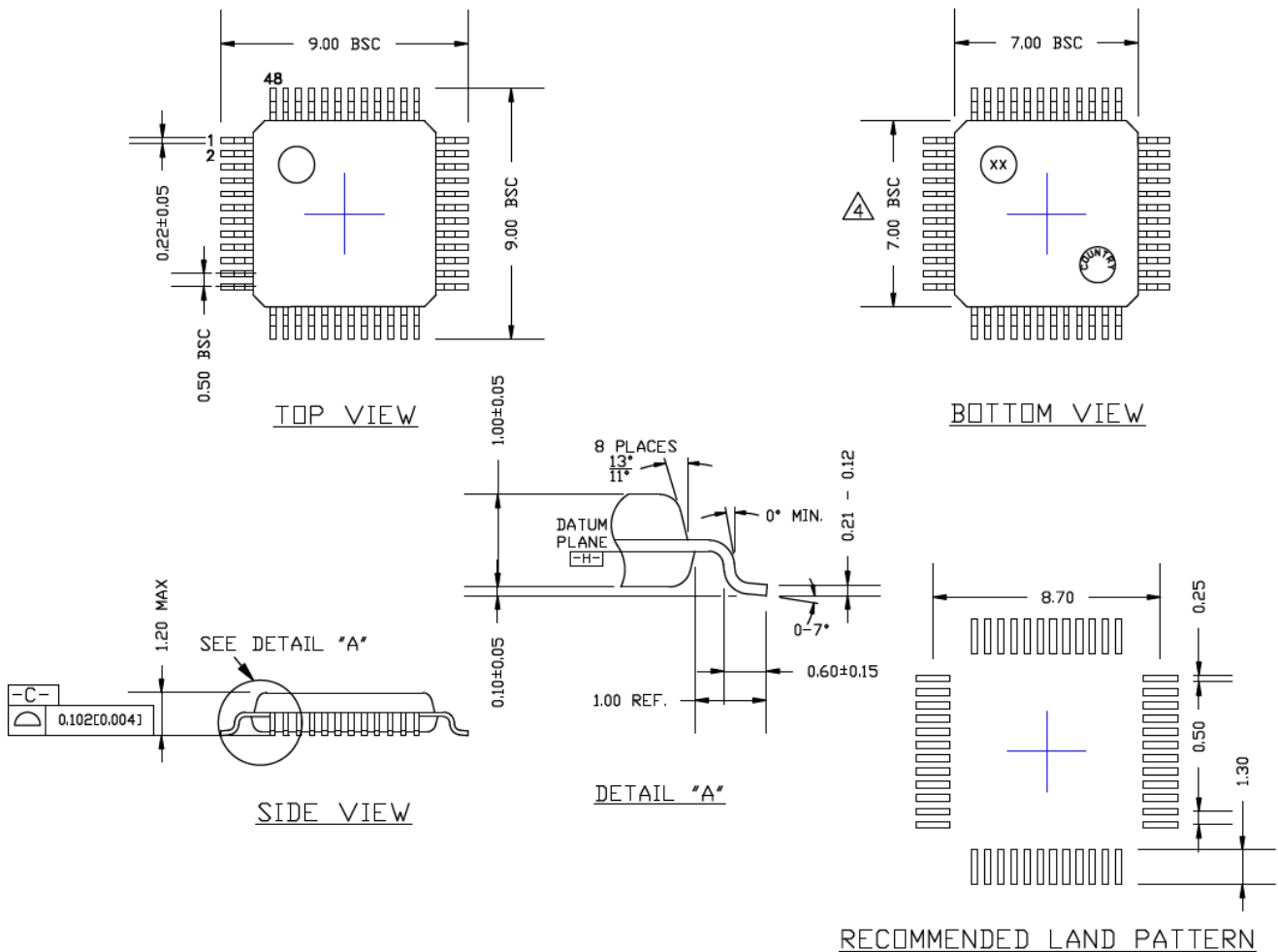

**NOTES :**

1. DIMENSION DOES NOT INCLUDE MOLD FLASH OR PROTRUSIONS, EITHER OF WHICH SHALL NOT EXCEED 0.254MM.
  2. LEAD DIMENSION DOES NOT INCLUDE DAMBAR PROTRUSION.
  3. PACKAGE TOP MOLD DIMENSIONS ARE SMALLER THAN BOTTOM
- ⚠️ MOLD DIMENSIONS AND TOP OF PACKAGE WILL NOT OVERHANG BOTTOM OF PACKAGE.

Note: For the most current package drawings, please see the Microchip Packaging Specification located at <http://www.microchip.com/packaging>.

**Package Outlines and Dimensions**

**TITLE**

48 LEAD TQFP 7X7 mm EPAD PACKAGE OUTLINE & RECOMMENDED LAND PATTERN

DRAWING #	TQFP7X7-48LD-PL-1	UNIT	MM
-----------	-------------------	------	----

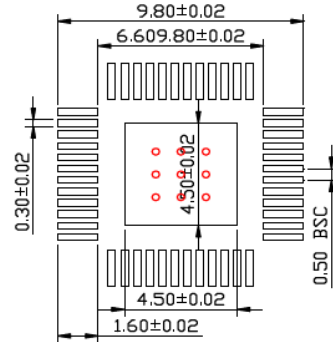
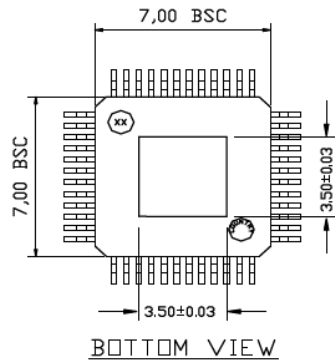
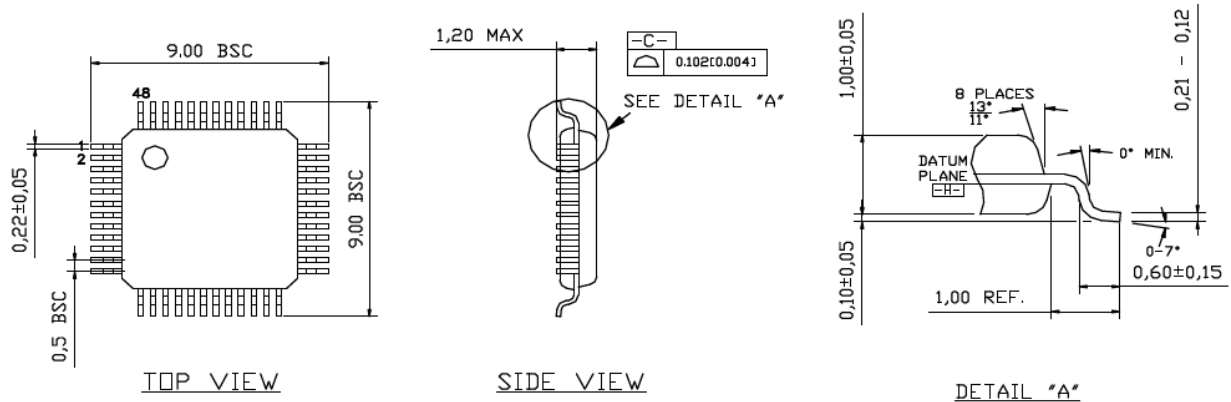

- NOTES**
1. DIMENSION DOES NOT INCLUDE MOLD FLASH OR PROTRUSIONS, EITHER OF WHICH SHALL NOT EXCEED 0.254MM.
  2. LEAD DIMENSION DOES NOT INCLUDE DAMBAR PROTRUSION.
  3. PACKAGE TOP MOLD DIMENSIONS ARE SMALLER THAN BOTTOM
  4. MOLD DIMENSIONS AND TOP OF PACKAGE WILL NOT OVERHANG BOTTOM OF PACKAGE.
  5. RED CIRCLES IN LAND PATTERN REPRESENT THERMAL VIAS. RECOMMENDED SIZE IS 0.30MM AND SHOULD BE CONNECTED TO GND FOR MAXIMUM PERFORMANCE

Note: For the most current package drawings, please see the Microchip Packaging Specification located at <http://www.microchip.com/packaging>.

**Package Outlines and Dimensions**

**TITLE**

64 LEAD TQFP 10x10mm PACKAGE OUTLINE & RECOMMENDED LAND PATTERN

<b>DRAWING #</b>	TQFP10x10-64LD-PL-1	<b>UNIT</b>	MM [INCH]
------------------	---------------------	-------------	-----------

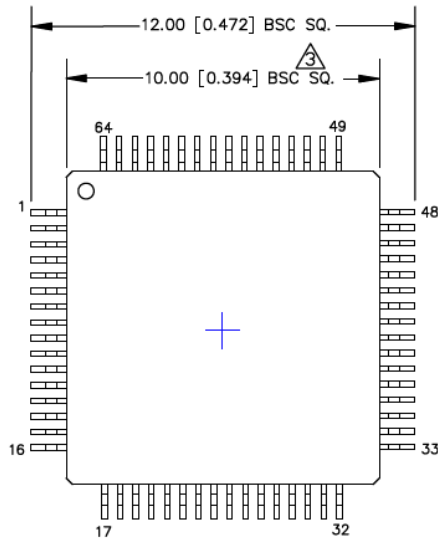

TOP/BOTTOM VIEW  
NOTES : 1, 2, 3

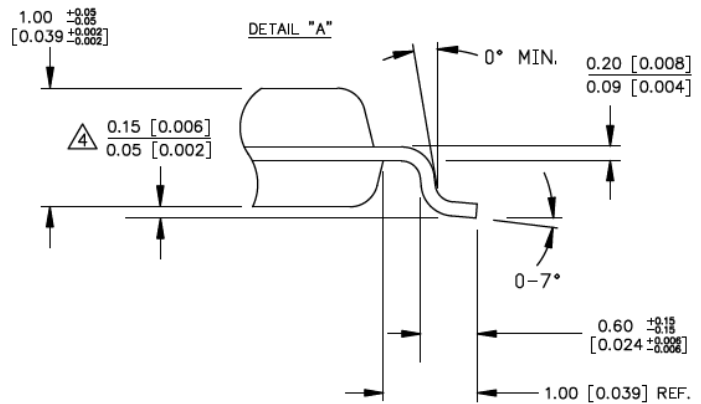

DETAIL VIEW  
NOTES : 1, 2, 4

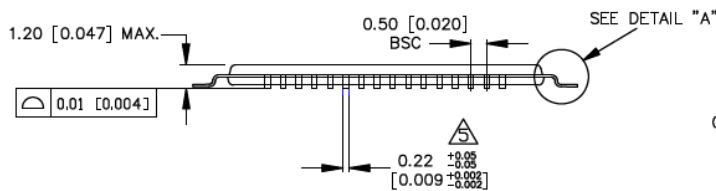

SIDE VIEW  
NOTES : 5

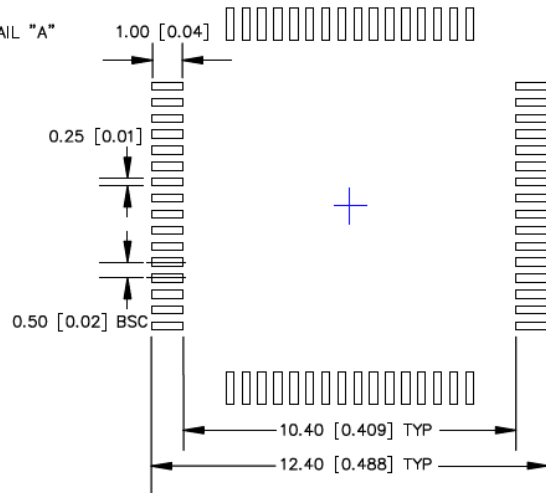

RECOMMENDED LAND PATTERN

**NOTES:**

1. DIMENSIONS ARE IN MM [INCHES].
2. CONTROLLING DIMENSION: MM.
3. DIMENSION DOES NOT INCLUDE MOLD FLASH OF 0.254[0.010] MAX.
4. MAXIMUM AND MINIMUM SPECIFICATIONS ARE INDICATED AS FOLLOWS:  $\frac{\text{MAX}}{\text{MIN}}$
5. THIS DIMENSION INCLUDES LEAD FINISH.

Note: For the most current package drawings, please see the Microchip Packaging Specification located at <http://www.microchip.com/packageing>.

## Package Outlines and Dimensions

### TITLE

64 LEAD TQFP 10X10 mm EPAD PACKAGE OUTLINE & RECOMMENDED LAND PATTERN

<b>DRAWING #</b>	TQFP10X10-64LD-PL-1	<b>UNIT</b>	MM [INCH]
------------------	---------------------	-------------	-----------

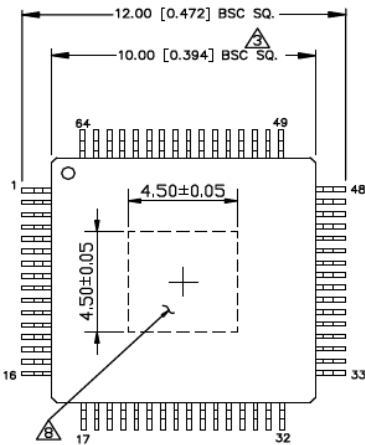

TOP/BOTTOM VIEW

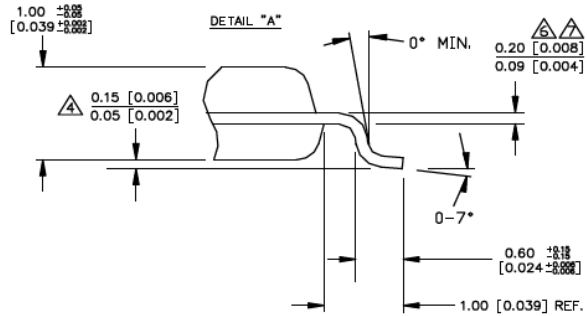

DETAIL VIEW

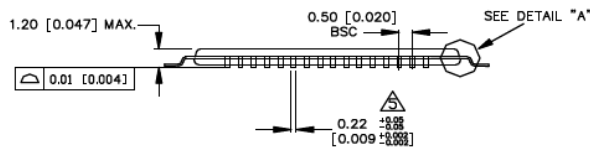

SIDE VIEW

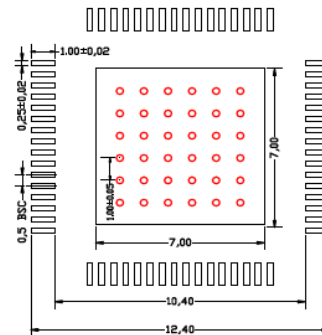

RECOMMENDED LAND PATTERN

### NOTES:

1. DIMENSIONS ARE IN MM [INCHES].
2. CONTROLLING DIMENSION: MM.
3. DIMENSION DOES NOT INCLUDE MOLD FLASH OF 0.254[0.010] MAX.
4. MAXIMUM AND MINIMUM SPECIFICATIONS ARE INDICATED AS FOLLOWS: MAX  
MIN
5. THIS DIMENSION INCLUDES LEAD FINISH.
6. LAND PATTERN TOLERANCE IS ±0,05 UNLESS OTHERWISE SPECIFIED
7. RED CIRCLES IN LAND PATTERN REPRESENT THERMAL VIAS. SIZE IS 0.30MM AND SHOULD BE CONNECTED TO GND FOR MAXIMUM PERFORMANCE
8. DIE UP ORIENTATION SHOW. EPAD IS VISIBLE FROM BOTTOM OF PACKAGE

Note: For the most current package drawings, please see the Microchip Packaging Specification located at <http://www.microchip.com/packaging>.

## Package Outlines and Dimensions

**TITLE**

80 LEAD TQFP 14x14mm EPAD PACKAGE OUTLINE & RECOMMENDED LAND PATTERN

<b>DRAWING #</b>	TQFP14x14-80LD-PL-1	<b>UNIT</b>	MM
------------------	---------------------	-------------	----

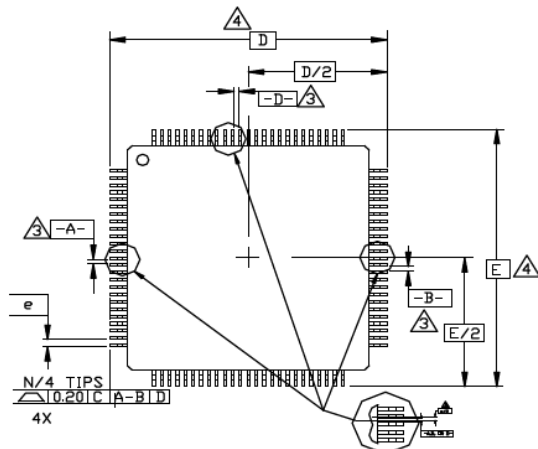

TOP VIEW

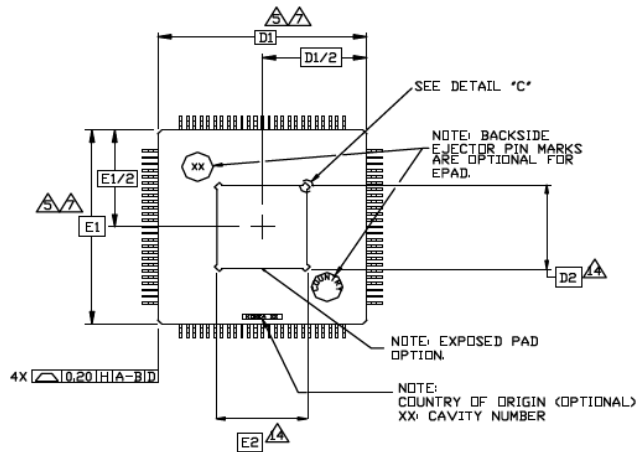

BOTTOM VIEW

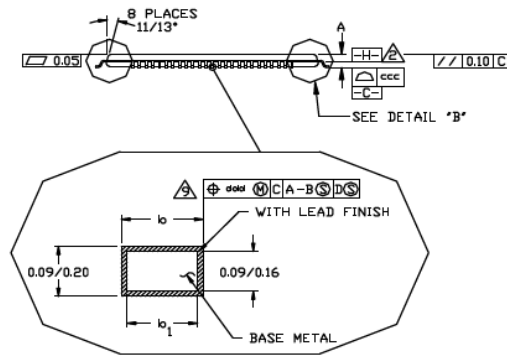

SIDE VIEW

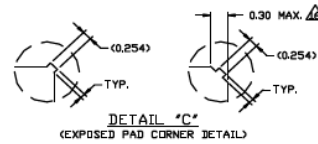

DETAIL "C"  
(EXPOSED PAD CORNER DETAIL)

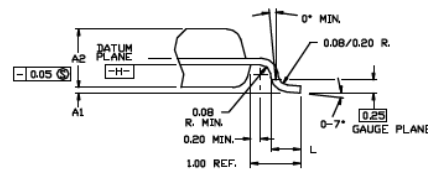

DETAIL "B"

DETAILED VIEW

**NOTES:**

1. ALL DIMENSIONS AND TOLERANCING CONFORM TO ANSI Y14.5-1998.
2. DATUM PLANE [C] LOCATED AT MOLD PARTING LINE AND COINCIDENT WITH LEAD WIRE LEAD EXITS PLASTIC BODY AT BOTTOM OF PARTING LINE.
3. DATUMS [A] AND [B] TO BE DETERMINED AT CENTERLINE BETWEEN LEADS WHERE LEADS EXIT PLASTIC BODY AT DATUM PLANE [C].
4. [A] TO BE DETERMINED AT SEATING PLANE [C].
5. DIMENSIONS D1 AND E1 DO NOT INCLUDE MOLD PROTRUSION. ALLOWABLE MOLD PROTRUSION IS 0.254 MM ON D1 AND E1 DIMENSIONS.
6. "N" IS THE TOTAL NUMBER OF TERMINALS.
7. THESE DIMENSIONS TO BE DETERMINED AT DATUM PLANE [C].
8. THE TOP OF PACKAGE IS SMALLER THAN THE BOTTOM OF PACKAGE BY 0.15 MILLIMETERS.
9. DIMENSION "b" DOES NOT INCLUDE SHANK PROTRUSION. ALLOWABLE SHANK PROTRUSION SHALL BE 0.08mm TOTAL IN EXCESS OF THE "b" DIMENSION AT MAXIMUM MATERIAL CONDITION. SHANKS CANNOT BE LOCATED ON THE LOWER RADIUS OR THE FOOT.
10. CONTROLLING DIMENSION MILLIMETERS.
11. MAXIMUM ALLOWABLE DIE THICKNESS TO BE ASSEMBLED IN THIS PACKAGE FAMILY IS 0.30 MILLIMETERS.
12. THIS OUTLINE CONFORMS TO JEDEC PUBLICATION 95 REGISTRATION MS-026, VARIATION AEC, AEC, AEC, & AEC (EXCEPT FOR 44 & 108 LEAD).
13. AS IS DEFINED AS THE DISTANCE FROM THE SEATING PLANE TO THE LOWEST POINT OF THE PACKAGE BODY.
14. DIMENSION "h" AND "e" REPRESENT THE SIZE OF THE EXPOSED PAD. THE ACTUAL DIMENSIONS ARE SPECIFIED ON THE BONDING DIAGRAM, AND IS DEPENDENT ON THE DIE SIZE.
15. EXPOSED PAD SHALL BE COPLANAR WITH BOTTOM OF PACKAGE WITHIN 0.05.
16. CORNER CHAMFER OF EXPOSED DIE PAD SHALL BE WITHIN 0.30 MM.

SYMBOL	JEDEC VARIATION ALL DIMENSIONS IN MILLIMETERS			DIE SIZE
	MIN.	NOM.	MAX.	
A			1.20	13
A1	0.05		0.15	
Ae	0.95	1.00	1.05	
D	16.00 BSC.			4
D1	14.00 BSC.			7.8
E	16.00 BSC.			4
E1	14.00 BSC.			7.8
L	0.45	0.60	0.75	
N	80			
e	0.65 BSC.			
h	0.22	0.32	0.38	9
b1	0.22	0.30	0.33	
ccc				0.10
dhd				0.13

Note: For the most current package drawings, please see the Microchip Packaging Specification located at <http://www.microchip.com/package>.

**Package Outlines and Dimensions**

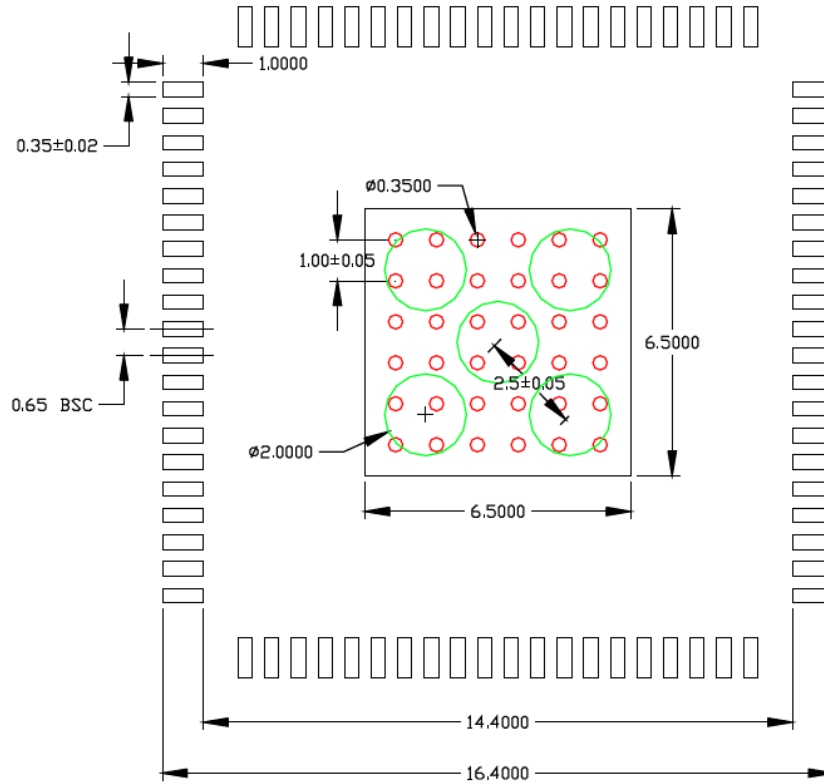

RECOMMENDED LAND PATTERN

1. RED CIRCLES REPRESENT THERMAL VIAS. RECOMMENDED SIZE IS 0.30–0.35MM AND SHOULD BE CONNECTED TO GND FOR MAXIMUM PERFORMANCE
2. GREEN CIRCLES REPRESENT COLDER STENCIL OPENING ON EXPOSED PAD AREA

Note: For the most current package drawings, please see the Microchip Packaging Specification located at <http://www.microchip.com/packaging>.

---

---

**Package Outlines and Dimensions**

---

---

**TSOT**

Micrel Legacy

## Package Outlines and Dimensions

### TITLE

5 LEAD TSOT PACKAGE OUTLINE & RECOMMENDED LAND PATTERN

<b>DRAWING #</b>	TSOT-5LD-PL-1	<b>UNIT</b>	MM
------------------	---------------	-------------	----

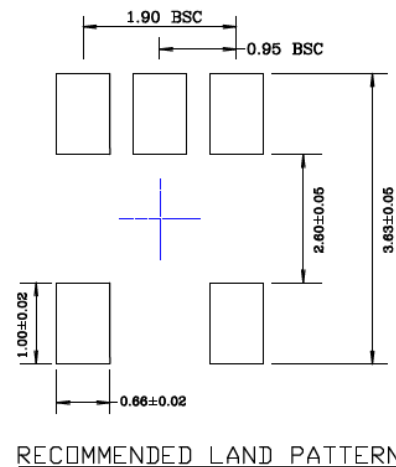
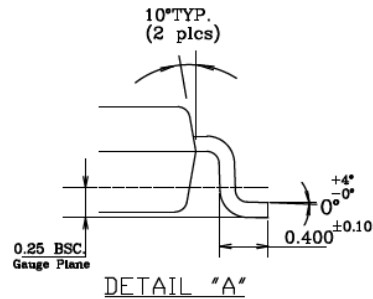
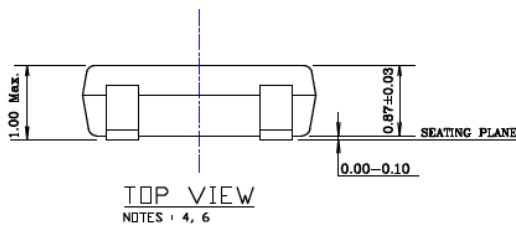
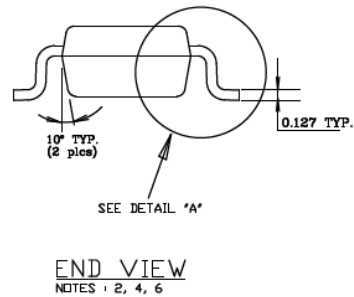
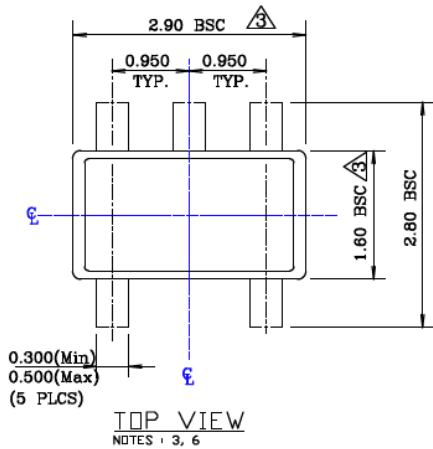

**NOTE:**

1. Dimensions and tolerances are as per ANSI Y14.5M, 1994.
2. Die is facing up for mold. Die is facing down for trim/form, ie. reverse trim/form.
3. Dimensions are exclusive of mold flash and gate burr.
4. The footlength measuring is based on the gauge plane method.
5. All specification comply to Jedec Spec MO193 Issue C.
6. All dimensions are in millimeters.

Note: For the most current package drawings, please see the Microchip Packaging Specification located at <http://www.microchip.com/packaging>.



**Package Outlines and Dimensions**

**TITLE**

6 LEAD TSOT PACKAGE OUTLINE & RECOMMENDED LAND PATTERN

<b>DRAWING #</b>	TSOT-6LD-PL-1	<b>UNIT</b>	MM
------------------	---------------	-------------	----

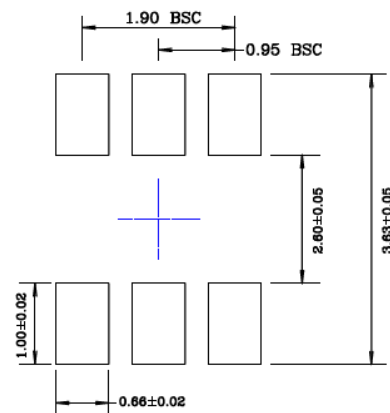
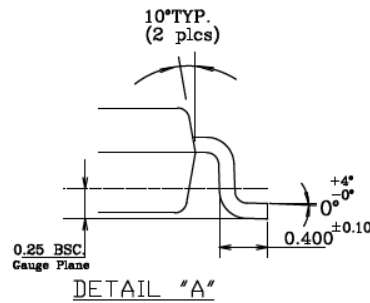
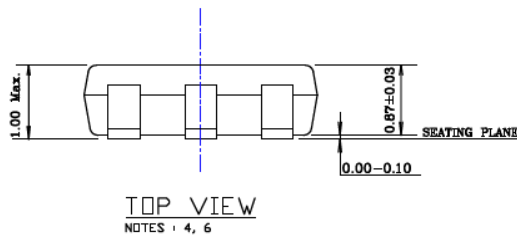
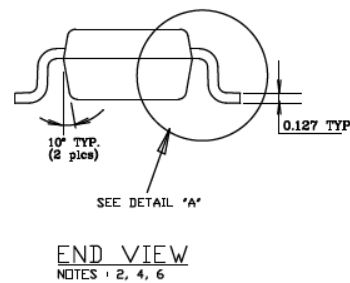
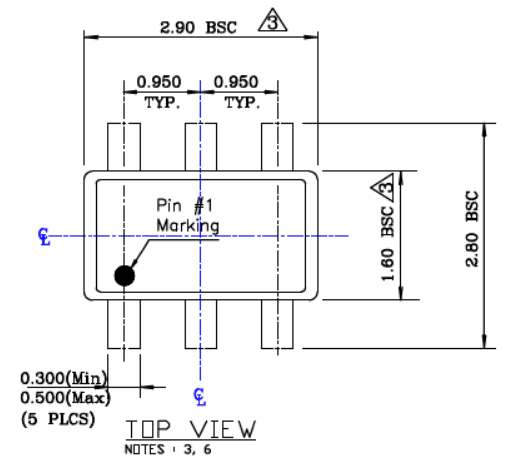

**NOTE:**

- Dimensions and tolerances are as per ANSI Y14.5M, 1994.
- Die is facing up for mold. Die is facing down for trim/form, ie. reverse trim/form.
- ⚠ Dimensions are exclusive of mold flash and gate burr.
- The footlength measuring is based on the gauge plane method.
- All specification comply to Jedec Spec MO193 Issue C.
- All dimensions are in millimeters.

Note: For the most current package drawings, please see the Microchip Packaging Specification located at <http://www.microchip.com/packageing>.



**MICROCHIP**

---

---

**Package Outlines and Dimensions**

---

---

**NOTES:**

---

---

**Package Outlines and Dimensions**

---

---

**TSSOP**

Micrel Legacy

## Package Outlines and Dimensions

### TITLE

8 LEAD TSSOP PACKAGE OUTLINE & RECOMMENDED LAND PATTERN

DRAWING #	TSSOP-8LD-PL-1	UNIT	MM
-----------	----------------	------	----

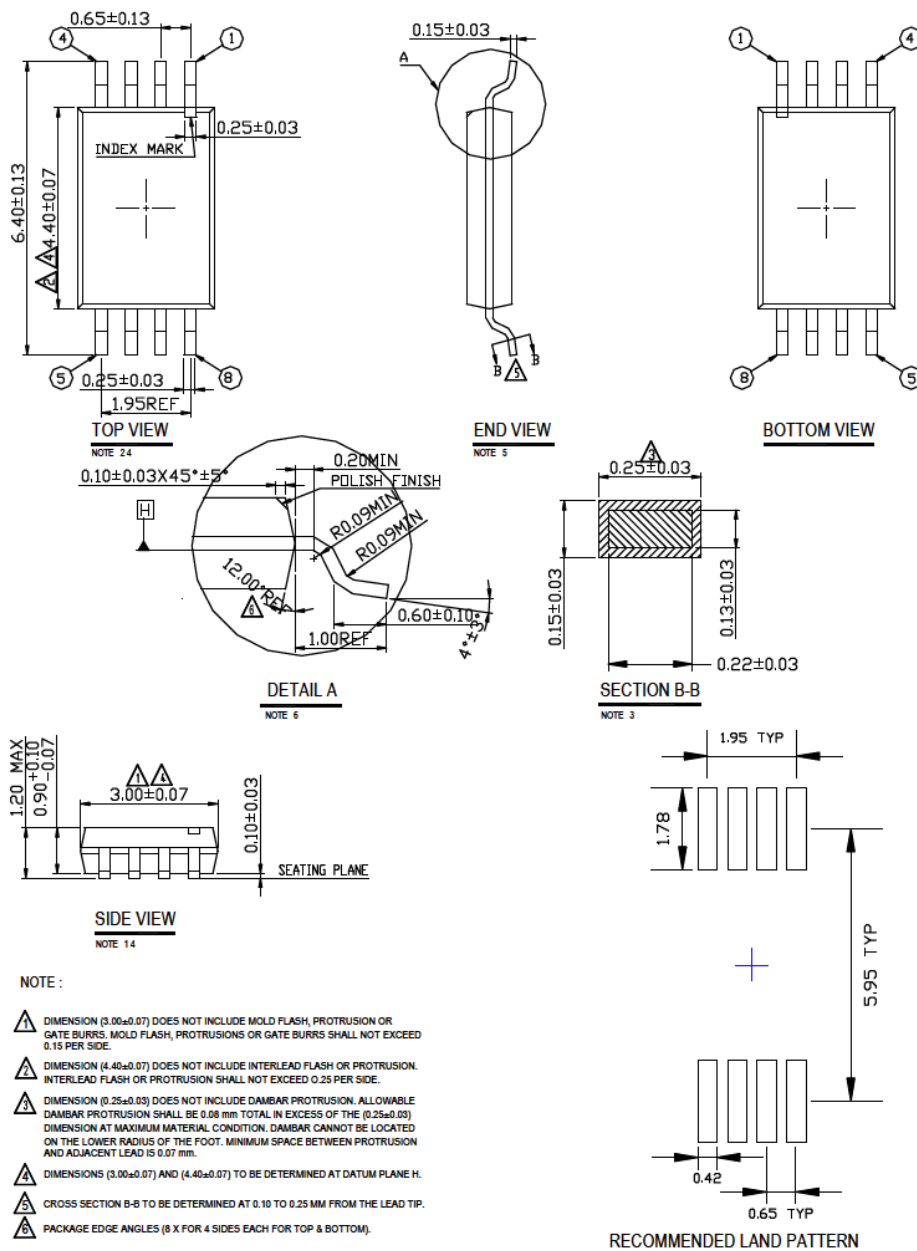

Note: For the most current package drawings, please see the Microchip Packaging Specification located at <http://www.microchip.com/packaging>.

**Package Outlines and Dimensions**

**TITLE**

14 LEAD TSSOP PACKAGE OUTLINE & RECOMMENDED LAND PATTERN

<b>DRAWING #</b>	TSSOP-14LD-PL-1	<b>UNIT</b>	MM [INCH]
------------------	-----------------	-------------	-----------

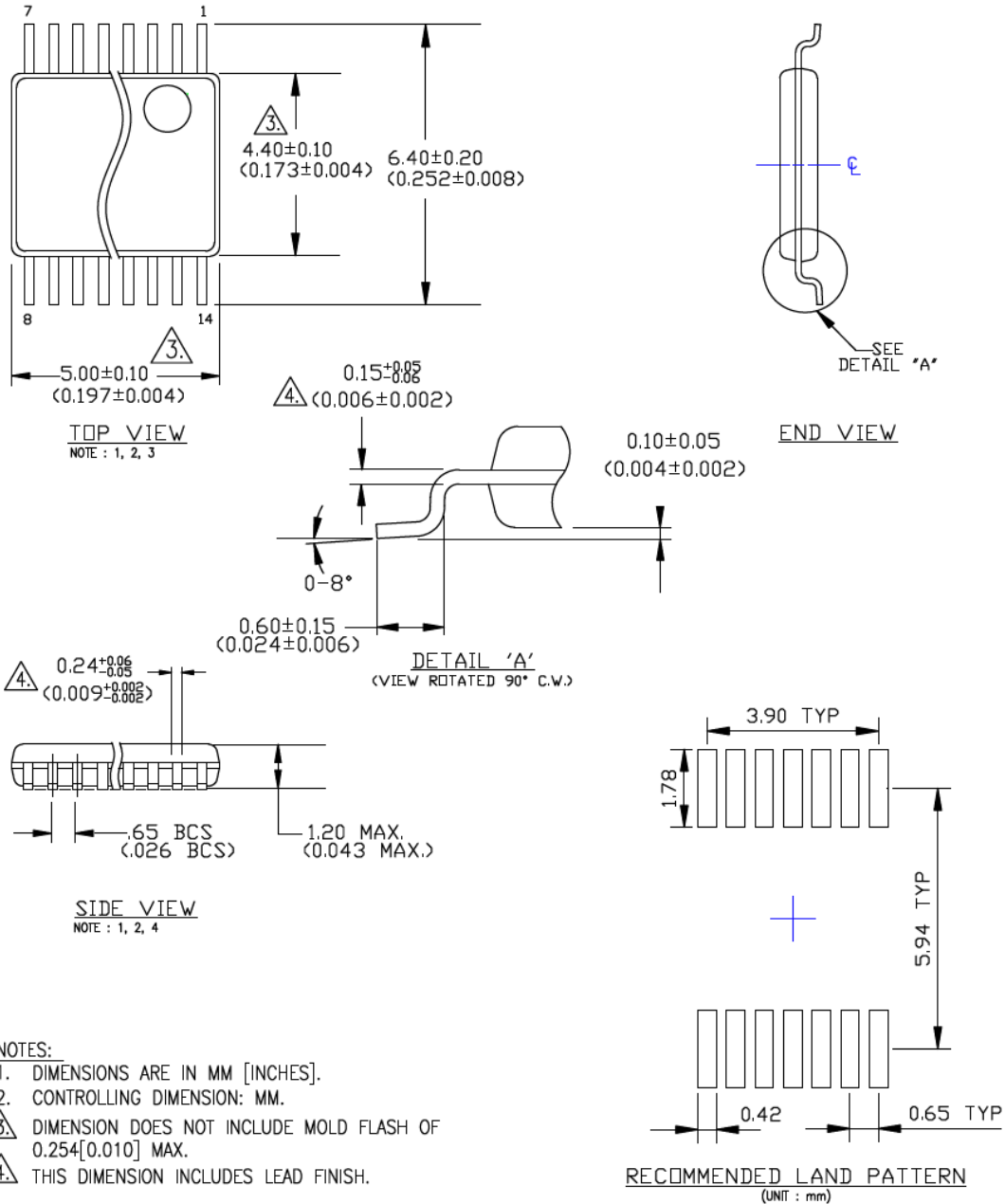

- NOTES:**
1. DIMENSIONS ARE IN MM [INCHES].
  2. CONTROLLING DIMENSION: MM.
  3. DIMENSION DOES NOT INCLUDE MOLD FLASH OF 0.254[0.010] MAX.
  4. THIS DIMENSION INCLUDES LEAD FINISH.

Note: For the most current package drawings, please see the Microchip Packaging Specification located at <http://www.microchip.com/packaging>.

## Package Outlines and Dimensions

### TITLE

16 LEAD TSSOP PACKAGE OUTLINE & RECOMMENDED LAND PATTERN

DRAWING #	TSSOP-16LD-PL-1	UNIT	MM
-----------	-----------------	------	----

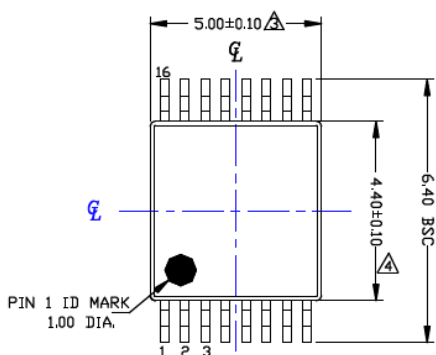

TOP VIEW

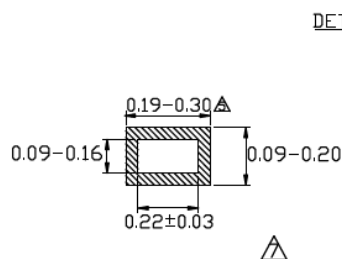

LEAD TIP DETAIL

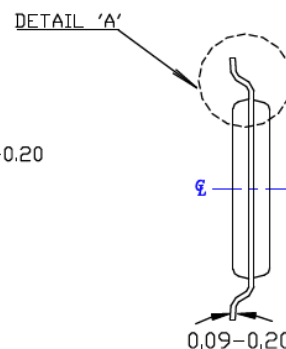

END VIEW

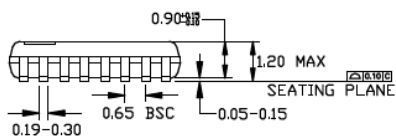

SIDE VIEW

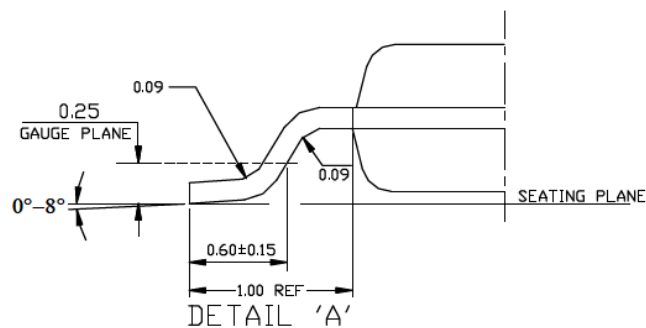

DETAIL 'A'

### Notes :

1. ALL DIMENSIONS ARE IN MILLIMETERS (ANGLES IN DEGREES).
  2. DIMENSIONING AND TOLERANCING PER ANSI Y14.5M-1994.
- △ DIMENSION DOES NOT INCLUDE MOLD FLASH, PROTRUSIONS OR GATE BURRS.
  - △ DIMENSION DOES NOT INCLUDE INTERNAL FLASH OR PROTRUSION.
  - △ DIMENSION DOES NOT INCLUDE DAMBAR PROTRUSION.
  - △ CROSS SECTION TO BE DETERMINED AT 0.10 TO 0.25MM FROM THE LEAD TIP.

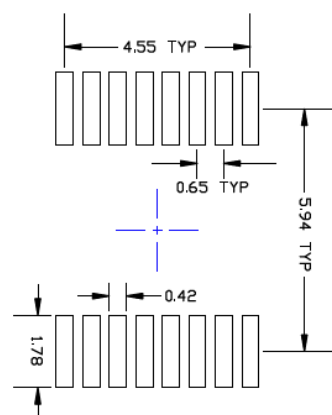

RECOMMENDED LAND PATTERN

Note: For the most current package drawings, please see the Microchip Packaging Specification located at <http://www.microchip.com/packaging>.

**Package Outlines and Dimensions**

**TITLE**

14/16 LEAD TSSOP EPAD PACKAGE OUTLINE & RECOMMENDED LAND PATTERN

<b>DRAWING #</b>	TSSOPEP-1416LD-PL-1	<b>UNIT</b>	INCH
------------------	---------------------	-------------	------

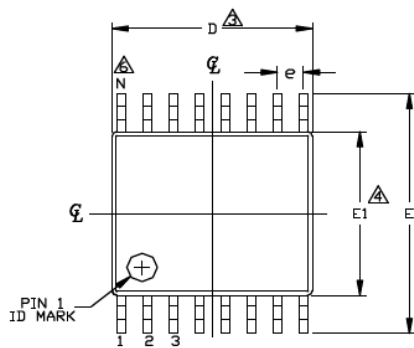

**TOP VIEW**

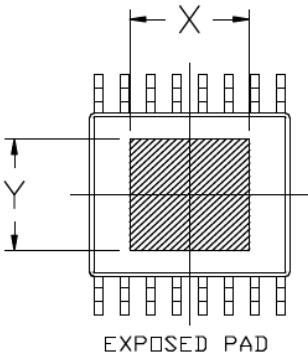
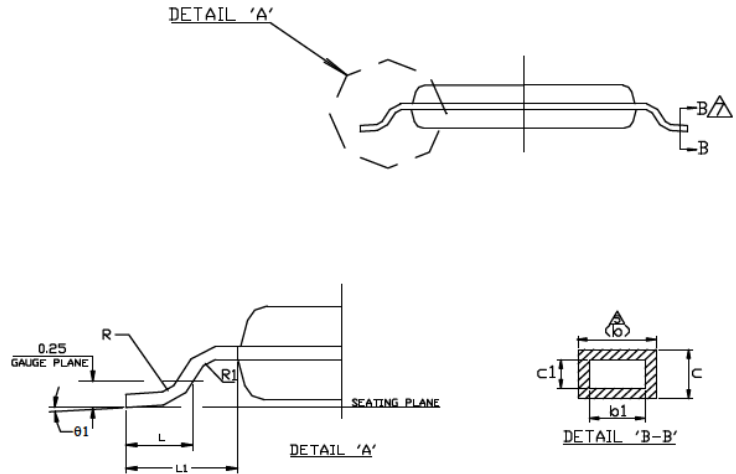

**BOTTOM VIEW**

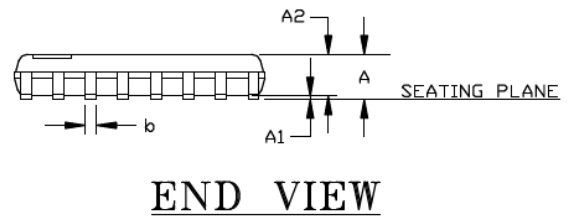

**END VIEW**

Note: For the most current package drawings, please see the Microchip Packaging Specification located at <http://www.microchip.com/packaging>.

## Package Outlines and Dimensions

SYMBOL	14L TSSOP Thermally Enhanced			16L TSSOP Thermally Enhanced		
	MIN	NOM.	MAX	MIN	NOM.	MAX
A	—	—	1.20	—	—	1.20
A1	0.025	—	0.100	0.025	—	0.100
A2	0.80	0.90	1.05	0.80	0.90	1.05
D	4.9	5.0	5.1	4.9	5.0	5.1
E1	4.3	4.4	4.5	4.3	4.4	4.5
E	6.2	6.4	6.6	6.2	6.4	6.6
L	0.45	0.60	0.75	0.45	0.60	0.75
R	0.09	—	—	0.09	—	—
R1	0.09	—	—	0.09	—	—
b	0.19	—	0.30	0.19	—	0.30
b1	0.19	0.22	0.25	0.19	0.22	0.25
c	0.09	—	0.20	0.09	—	0.20
c1	0.09	—	0.16	0.09	—	0.16
θ1	0°	—	8°	0°	—	8°
L1	1.0 REF			1.0 REF		
e	0.65 BSC			0.65 BSC		
N	14			16		
Ref.	Jedec MO-153 Issue C Variation ABT-1			Jedec MO-153 Issue C Variation ABT		
EP Area	Pad Size □p 1	X 2.997	Y 3.200	Pad Size □p 1	X 2.997	Y 2.997

### Notes

1. ALL DIMENSIONS ARE IN MILLIMETERS (ANGLES IN DEGREES).
2. DIMENSIONING AND TOLERANCING PER ANSI Y14.5M-1982.
- △ DIMENSION 'D' DOES NOT INCLUDE MOLD FLASH, PROTRUSIONS OR GATE BURRS.
- △ DIMENSION 'E1' DOES NOT INCLUDE INTERNAL FLASH OR PROTRUSION.
- △ DIMENSION 'b' DOES NOT INCLUDE DAMBAR PROTRUSION.
- △ 'N' IS THE MAXIMUM NUMBER OF LEAD TERMINAL POSITIONS FOR THE SPECIFIED PACKAGE LENGTH.
- △ CROSS SECTION B-B TO BE DETERMINED AT 0.10 TO 0.25MM FROM THE LEAD TIP.
8. EXPOSED PAD WILL BE DEPEND ON THE PAD SIZE OF THE L/F.

Note: For the most current package drawings, please see the Microchip Packaging Specification located at <http://www.microchip.com/packaging>.



---



---

**Package Outlines and Dimensions**

---



---

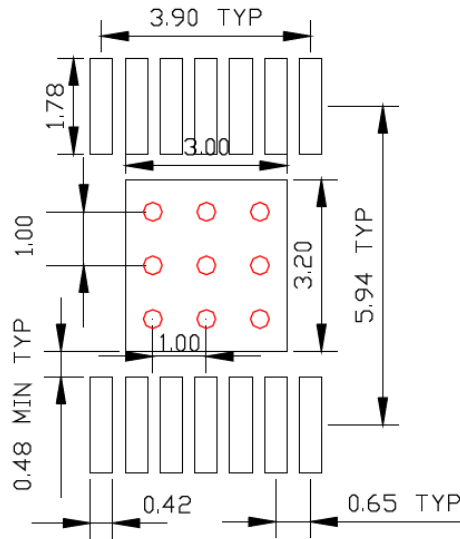

RECOMMENDED LAND PATTERN  
TSSOPPEP-14LD

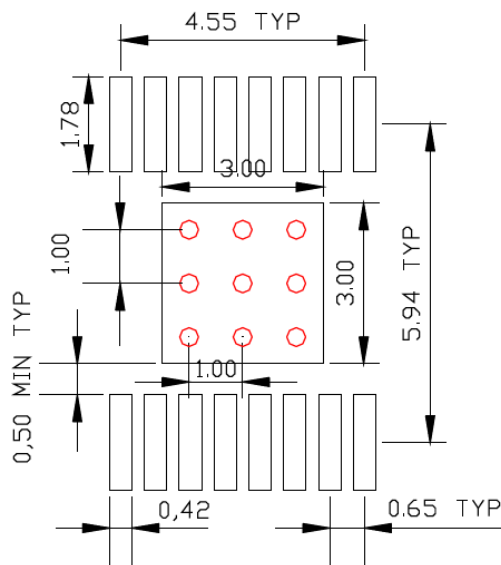

RECOMMENDED LAND PATTERN  
TSSOPPEP-16LD

Note: For the most current package drawings, please see the Microchip Packaging Specification located at <http://www.microchip.com/packaging>.

## Package Outlines and Dimensions

### TITLE

20 LEAD TSSOP PACKAGE OUTLINE & RECOMMENDED LAND PATTERN

DRAWING #	TSSOP-20LD-PL-1	UNIT	MM [INCH]
-----------	-----------------	------	-----------

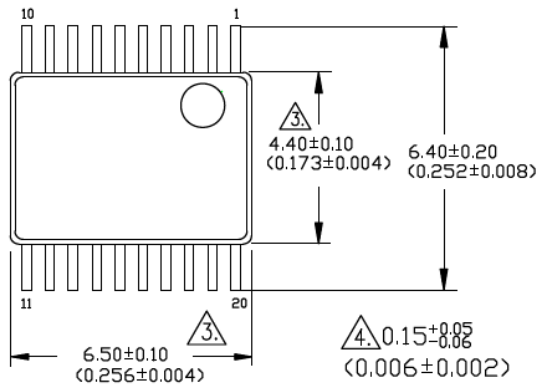

**TOP VIEW**  
NOTES : 1, 2, 3

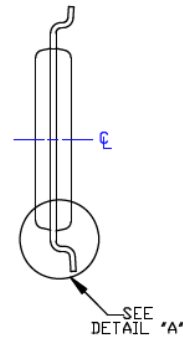

**END VIEW**

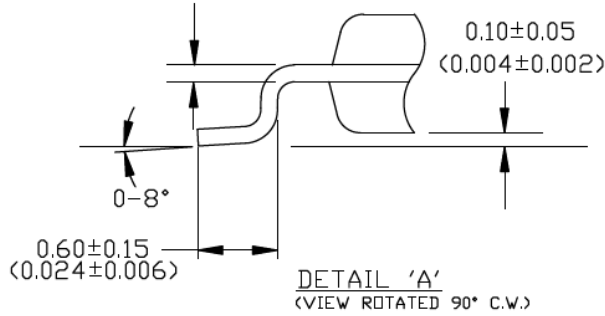

**DETAIL 'A'**  
(VIEW ROTATED 90° C.W.)

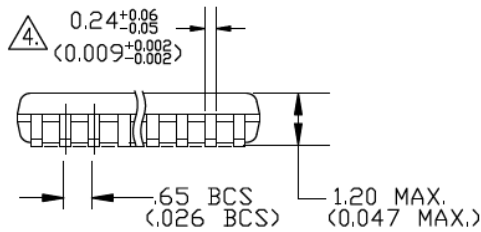

**SIDE VIEW**  
NOTES : 1, 2, 4

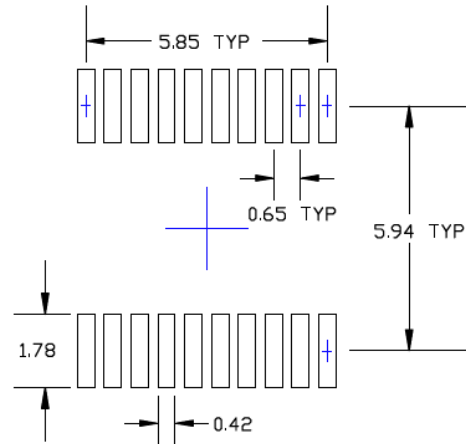

**RECOMMENDED LAND PATTERN**

### NOTES:

1. DIMENSIONS ARE IN MM [INCHES].
2. CONTROLLING DIMENSION: MM.
3. DIMENSION DOES NOT INCLUDE MOLD FLASH OF 0.254[0.010] MAX.
4. THIS DIMENSION INCLUDES LEAD FINISH.

Note: For the most current package drawings, please see the Microchip Packaging Specification located at <http://www.microchip.com/package>.

**Package Outlines and Dimensions**

**TITLE**

20 LEAD TSSOP EPAD PACKAGE OUTLINE & RECOMMENDED LAND PATTERN

DRAWING #	TSSOPEP-20LD-PL-1	UNIT	MM (INCH)
-----------	-------------------	------	-----------

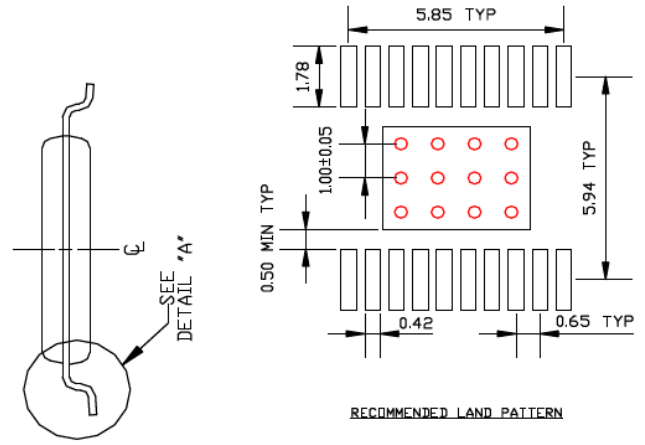
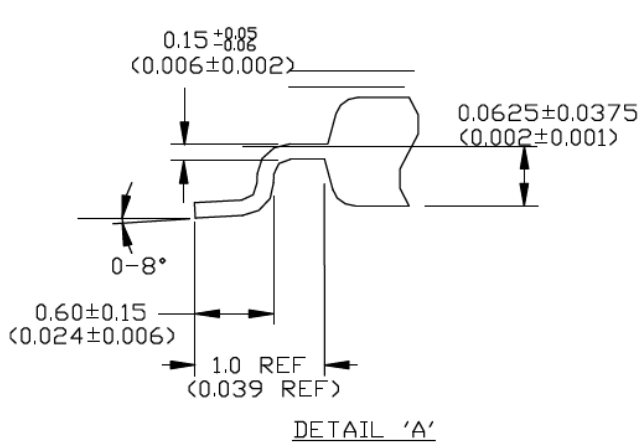
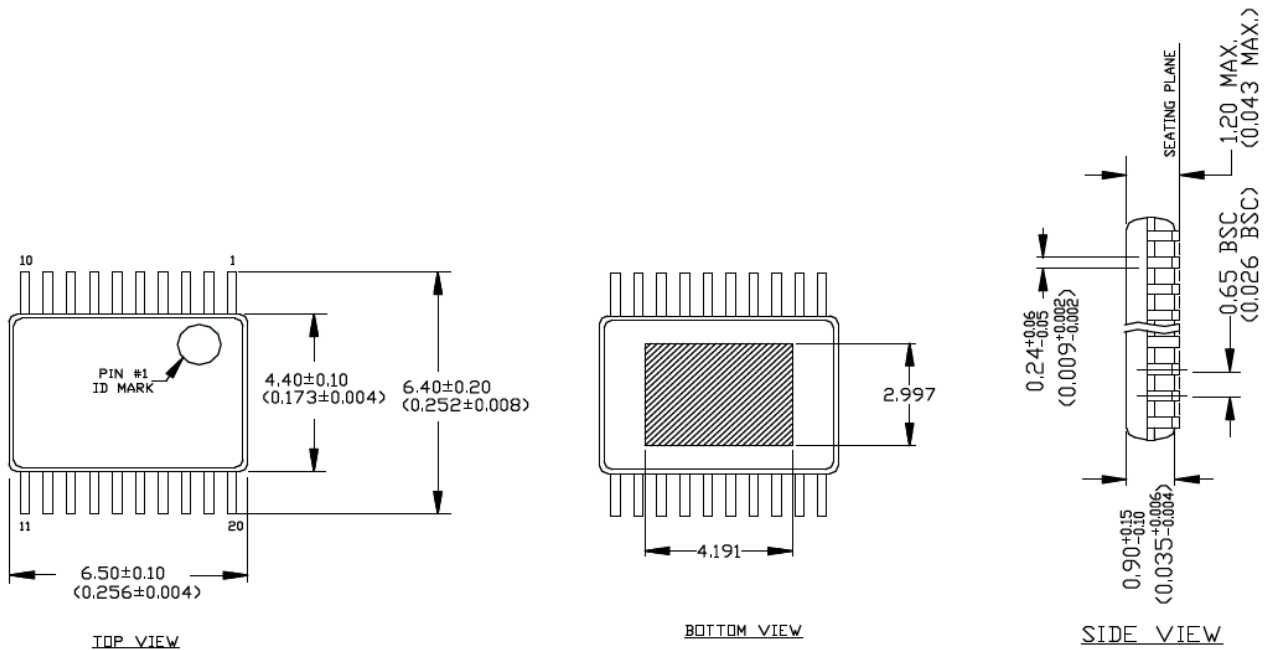

**NOTE:**

1. DIMENSION DOES NOT INCLUDE MOLD FLASH OF 0.254 (0.010) MAX.
2. DIMENSION INCLUDES LEAD FINISH WHERE APPLICABLE
3. RED CIRCLES IN LAND PATTERN REPRESENT THERMAL VIAS. RECOMMENDED SIZE IS 0.30-0.35MM IN DIAMETER, 1.00 PITCH AND SHOULD BE CONNECTED TO GND FOR MAXIMUM PERFORMANCE

Note: For the most current package drawings, please see the Microchip Packaging Specification located at <http://www.microchip.com/packaging>.

## Package Outlines and Dimensions

### TITLE

24 LEAD TSSOP PACKAGE OUTLINE & RECOMMENDED LAND PATTERN

<b>DRAWING #</b>	TSSOP-24LD-PL-1	<b>UNIT</b>	MM [INCH]
------------------	-----------------	-------------	-----------

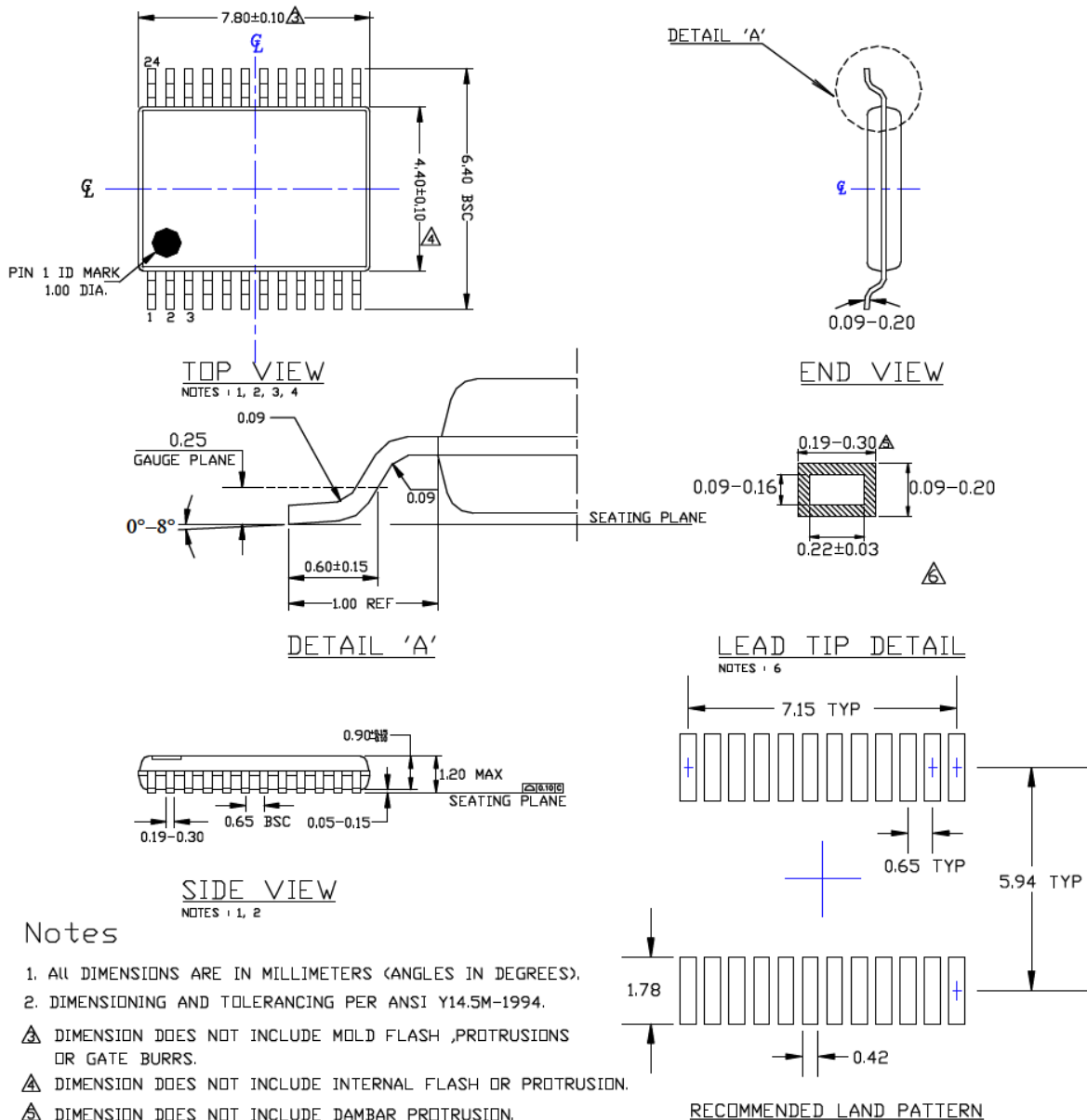

### Notes

1. ALL DIMENSIONS ARE IN MILLIMETERS (ANGLES IN DEGREES).
  2. DIMENSIONING AND TOLERANCING PER ANSI Y14.5M-1994.
- $\Delta$  DIMENSION DOES NOT INCLUDE MOLD FLASH, PROTRUSIONS OR GATE BURRS.
  - $\Delta$  DIMENSION DOES NOT INCLUDE INTERNAL FLASH OR PROTRUSION.
  - $\Delta$  DIMENSION DOES NOT INCLUDE DAMBAR PROTRUSION.
  - $\Delta$  CROSS SECTION TO BE DETERMINED AT 0.10 TO 0.25MM FROM THE LEAD TIP.

Note: For the most current package drawings, please see the Microchip Packaging Specification located at <http://www.microchip.com/packaging>.

**Package Outlines and Dimensions**

**TITLE**

24 LEAD TSSOP EPAD (4.3x3.0 EPAD) PACKAGE OUTLINE & RECOMMENDED LAND PATTERN

DRAWING #	TSSOPEP-24LD-PL-1	UNIT	MM (INCH)
-----------	-------------------	------	-----------

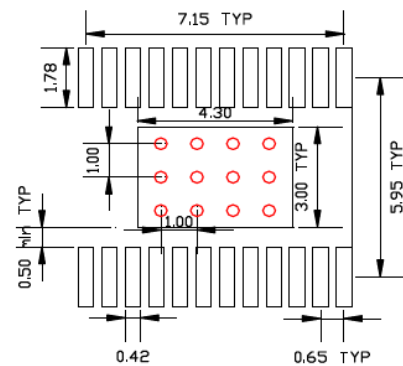
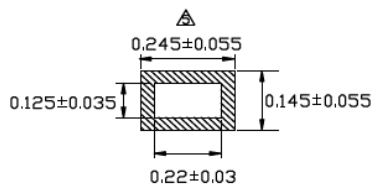
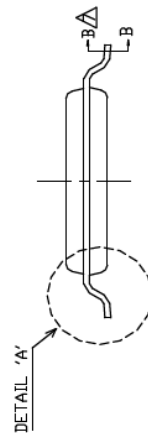
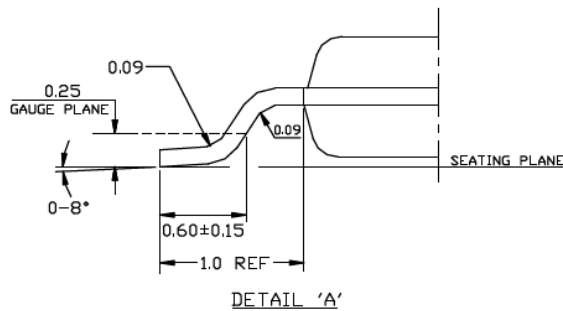
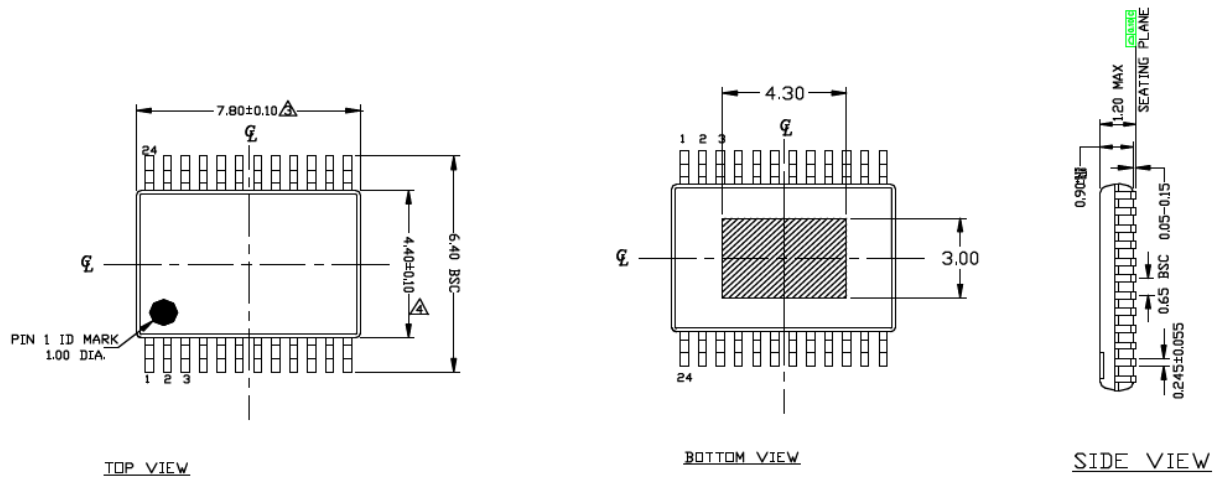

**NOTE:**

1. RED CIRCLES IN LAND PATTERN REPRESENT THERMAL VIAS. RECOMMENDED SIZE IS 0.30-0.35MM IN DIAMETER, 1.00 PITCH AND SHOULD BE CONNECTED TO GND FOR MAXIMUM PERFORMANCE
2. DIMENSIONS DO NOT INCLUDE MOLD FLASH, PROTRUSIONS & BURR

Note: For the most current package drawings, please see the Microchip Packaging Specification located at <http://www.microchip.com/packaging>.

## Package Outlines and Dimensions

### TITLE

24 LEAD TSSOP EPAD (5.5x3.0MM EPAD) PACKAGE OUTLINE & RECOMMENDED LAND PATTERN

DRAWING #	TSSOPEP-24LD-PL-2	UNIT	MM (INCH)
-----------	-------------------	------	-----------

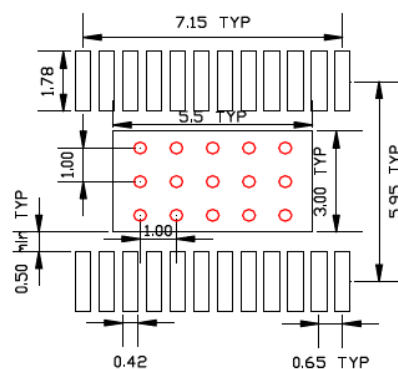
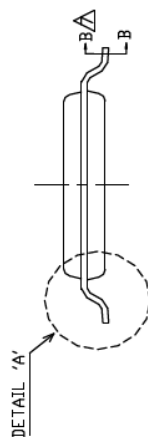
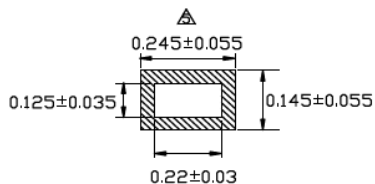
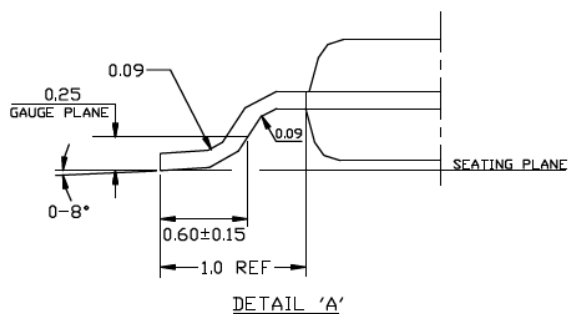
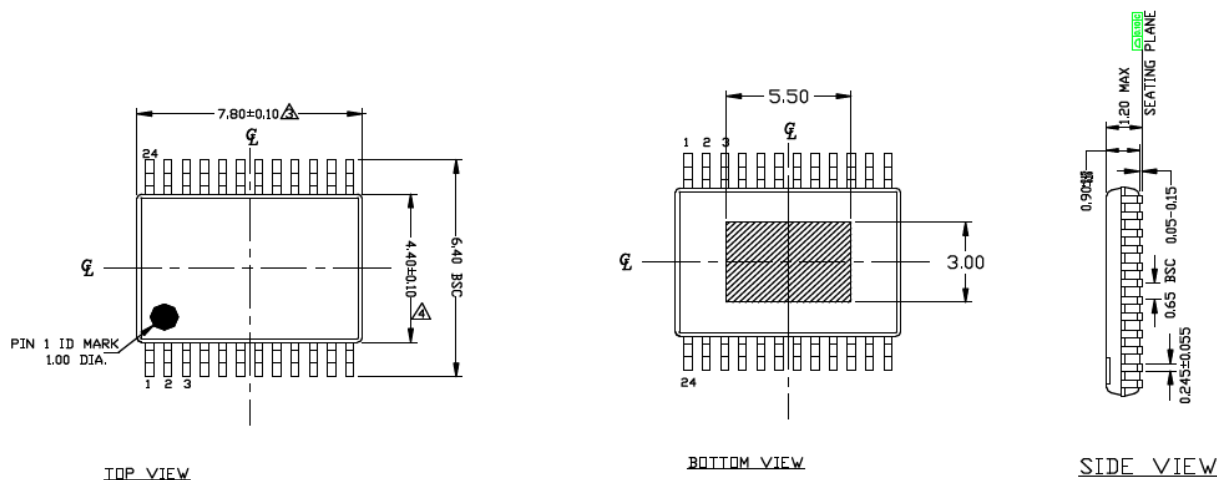

DETAIL 'B-B'

END VIEW

RECOMMENDED LAND PATTERN

### NOTE:

1. RED CIRCLES IN LAND PATTERN REPRESENT THERMAL VIAS. RECOMMENDED SIZE IS 0.30-0.35MM IN DIAMETER, 1.00 PITCH AND SHOULD BE CONNECTED TO GND FOR MAXIMUM PERFORMANCE
2. DIMENSIONS DO NOT INCLUDE MOLD FLASH, PROTRUSIONS & BURR

Note: For the most current package drawings, please see the Microchip Packaging Specification located at <http://www.microchip.com/packaging>.

**Package Outlines and Dimensions**

**TITLE**

28 LEAD TSSOP PACKAGE OUTLINE & RECOMMENDED LAND PATTERN

<b>DRAWING #</b>	TSSOP-28LD-PL-1	<b>UNIT</b>	MM [INCH]
------------------	-----------------	-------------	-----------

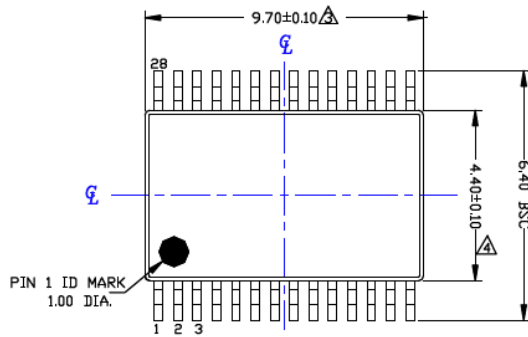

**TOP VIEW**  
NOTES: 1, 2, 3, 4

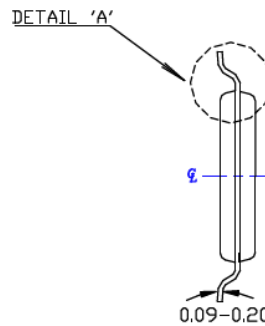

**END VIEW**

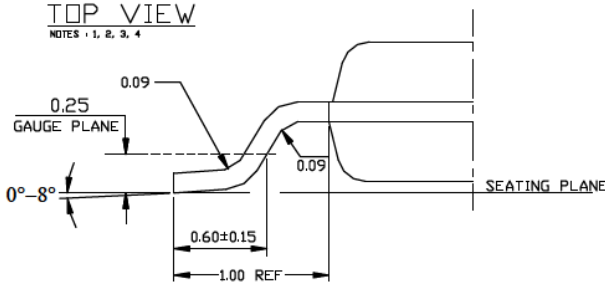

**DETAIL 'A'**

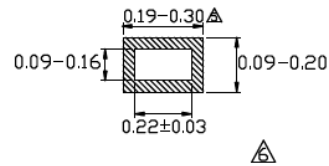

**LEAD TIP DETAIL**  
NOTES: 6

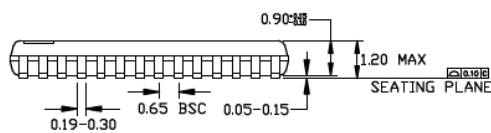

**SIDE VIEW**  
NOTES: 1, 2

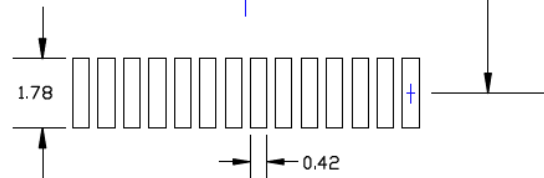
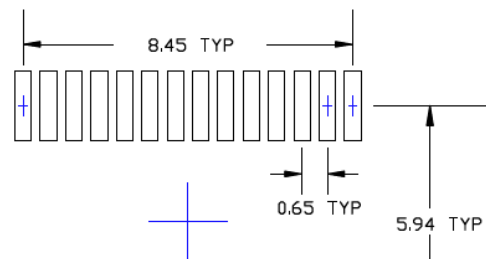

**RECOMMENDED LAND PATTERN**

**Notes**

1. ALL DIMENSIONS ARE IN MILLIMETERS (ANGLES IN DEGREES).
2. DIMENSIONING AND TOLERANCING PER ANSI Y14.5M-1994.
- △ DIMENSION DOES NOT INCLUDE MOLD FLASH, PROTRUSIONS OR GATE BURRS.
- △ DIMENSION DOES NOT INCLUDE INTERNAL FLASH OR PROTRUSION.
- △ DIMENSION DOES NOT INCLUDE DAMBAR PROTRUSION.
- △ CROSS SECTION TO BE DETERMINED AT 0.10 TO 0.25MM FROM THE LEAD TIP.

Note: For the most current package drawings, please see the Microchip Packaging Specification located at <http://www.microchip.com/packageing>.



**MICROCHIP**

---

---

**Package Outlines and Dimensions**

---

---

**NOTES:**



---

---

**Package Outlines and Dimensions**

---

---

**UTDFN**

Micrel Legacy

## Package Outlines and Dimensions

### TITLE

10 LEAD UTDFN 2.0x2.0 mm PACKAGE OUTLINE & RECOMMENDED LAND PATTERN

<b>DRAWING #</b>	UTDFN22-10LD-PL-1	<b>UNIT</b>	MM
<b>Lead Frame</b>	Copper	<b>Lead Finish</b>	Au-Ni-Au

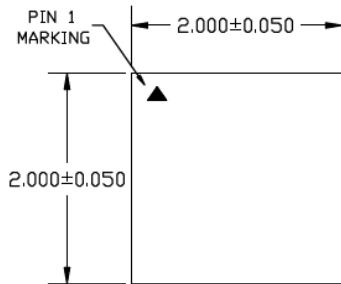

TOP VIEW  
NOTE: 1,2,3,4

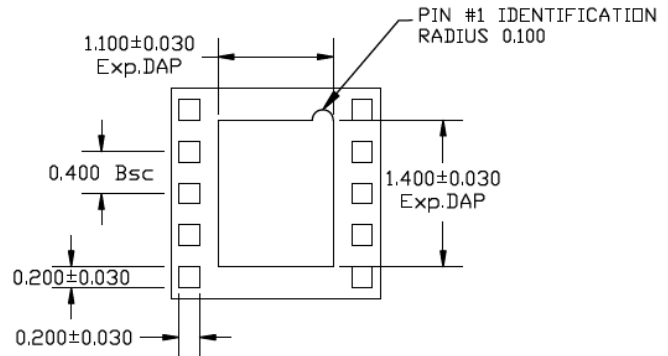

BOTTOM VIEW  
NOTE: 1,2,3,4



SIDE VIEW  
NOTE: 1,2,3,4

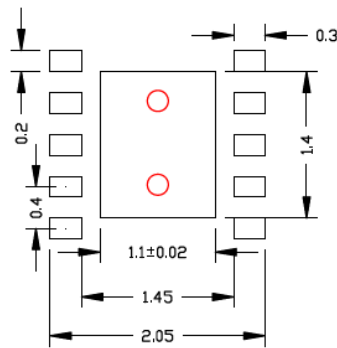

RECOMMENDED LAND PATTERN  
NOTE: 5

**NOTE:**

1. ALL DIMENSIONS ARE IN MILLIMETERS.
2. MAX. PACKAGE WARPAGE IS 0.08 mm.
3. MAXIMUM ALLOWABLE BURRS IS 0.076 mm IN ALL DIRECTIONS.
4. PIN #1 ID ON TOP WILL BE LASER MARKED.
5. Red Circle indicates Thermal Via. Size should be 0.200mm to 0.0350mm in diameter, 0.80mm pitch, and should be connected to ground plane for maximum thermal performance.

Note: For the most current package drawings, please see the Microchip Packaging Specification located at <http://www.microchip.com/packaging>.

---

---

**Package Outlines and Dimensions**

---

---

**WLCSP**

Micrel Legacy

## Package Outlines and Dimensions

**TITLE**

4 BALL WLCSP 0.88x0.88mm PACKAGE OUTLINE & RECOMMENDED LAND PATTERN

<b>DRAWING #</b>	WLCSP088088D-4BL-PL-9	<b>UNIT</b>	MM
------------------	-----------------------	-------------	----

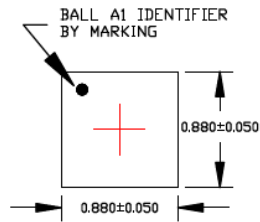

TOP VIEW  
NOTE: 1,2

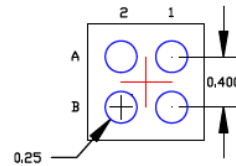

BOTTOM VIEW  
NOTE: 1,2

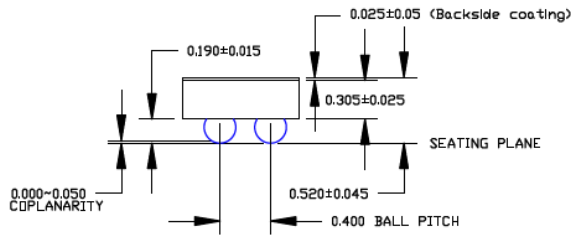

SIDE VIEW  
NOTE: 1,2

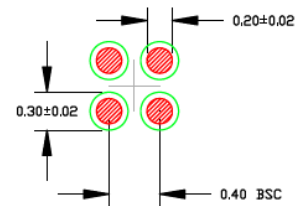

RECOMMENDED LAND PATTERN  
NOTE: 3,4

**NOTE:**

1. MAX PACKAGE WARPAGE IS 0.05 MM
2. MAX ALLOWABLE BURR IS 0.076MM IN ALL DIRECTIONS
3. NON-SOLDERMASK DEFINED PADS ARE RECOMMENDED FOR BOARD LAYOUT
4. SHADED RED CIRCLES REPRESENT CONTACT PAD AREA. GREEN CIRCLES REPRESENT SOLDER MASK OPENING

Note: For the most current package drawings, please see the Microchip Packaging Specification located at <http://www.microchip.com/packaging>.

**Package Outlines and Dimensions**

**TITLE**

6 BALL WLCSP 1.5x1.0mm PACKAGE OUTLINE & RECOMMENDED LAND PATTERN

<b>DRAWING #</b>	WLCSP1510D-6BL-PL-9	<b>UNIT</b>	MM
------------------	---------------------	-------------	----

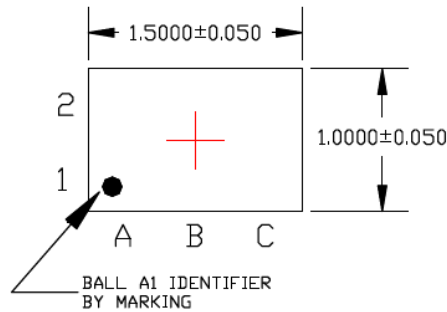

TOP VIEW  
NOTE: 1, 2

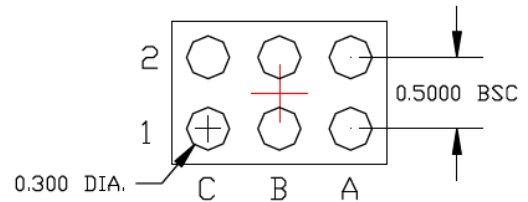

BOTTOM VIEW  
NOTE: 1, 2

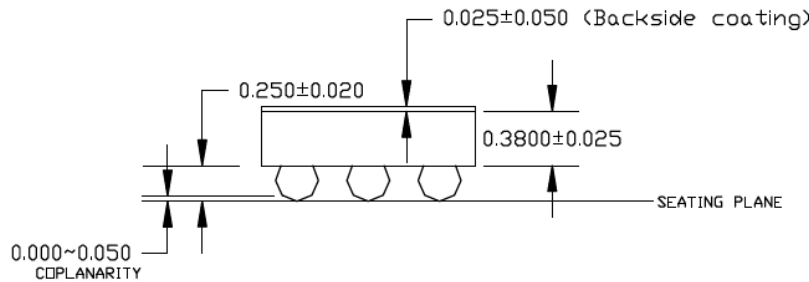

SIDE VIEW  
NOTE: 1, 2

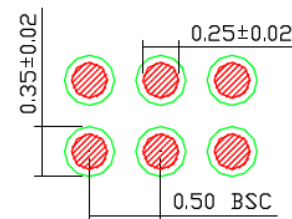

RECOMMENDED LAND PATTERN  
NOTE: 3, 4

**NOTE:**

1. MAX PACKAGE WARPAGE IS 0.05 MM
2. MAX ALLOWABLE BURR IS 0.076MM IN ALL DIRECTIONS
3. NON-SOLDERMASK DEFINED PADS ARE RECOMMENDED FOR BOARD LAYOUT
4. SHADED RED CIRCLES REPRESENT CONTACT PAD AREA, GREEN CIRCLES REPRESENT SOLDER MASK OPENING

Note: For the most current package drawings, please see the Microchip Packaging Specification located at <http://www.microchip.com/packaging>.

**Package Outlines and Dimensions**

**TITLE**

6 BALL WL CSP 0.80x1.20mm PACKAGE OUTLINE & RECOMMENDED LAND PATTERN

<b>DRAWING #</b>	WL CSP080120D-6BL-PL-9	<b>UNIT</b>	MM
------------------	------------------------	-------------	----

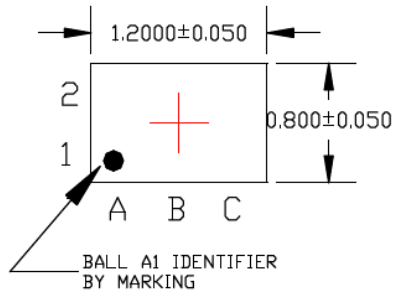

TOP VIEW  
NOTE: 1, 2

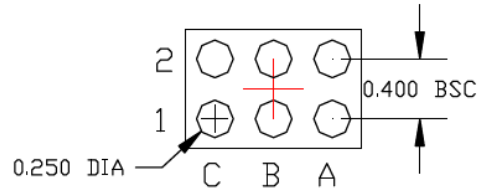

BOTTOM VIEW  
NOTE: 1, 2

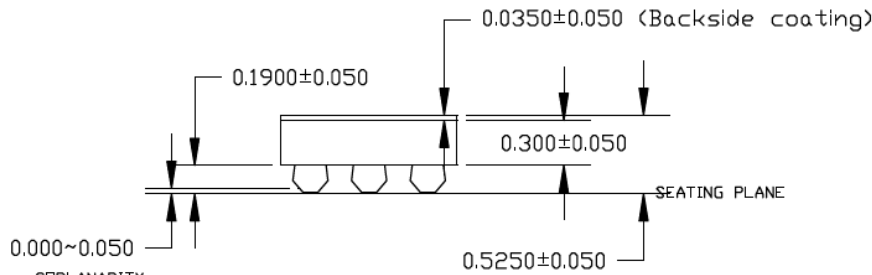

SIDE VIEW  
NOTE: 1, 2

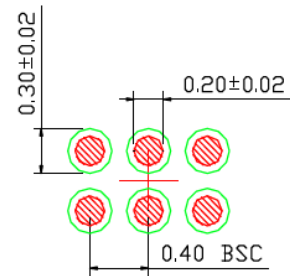

RECOMMENDED LAND PATTERN

NOTE: 3, 4

**NOTE:**

1. MAX PACKAGE WARPAGE IS 0.05 MM
2. MAX ALLOWABLE BURR IS 0.076MM IN ALL DIRECTIONS
3. NON-SOLDERMASK DEFINED PADS ARE RECOMMENDED FOR BOARD LAYOUT
4. SHADED RED CIRCLES REPRESENT CONTACT PAD AREA. GREEN CIRCLES REPRESENT SOLDER MASK OPENING

Note: For the most current package drawings, please see the Microchip Packaging Specification located at <http://www.microchip.com/packaging>.

**Package Outlines and Dimensions**

**TITLE**

6 BALL WLCSP 0.84x1.32mm PACKAGE OUTLINE & RECOMMENDED LAND PATTERN

DRAWING #	WLCSP084132D-6BL-PL-9	UNIT	MM
-----------	-----------------------	------	----

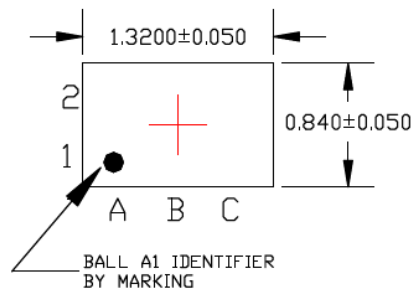

TOP VIEW  
NOTE: 1, 2

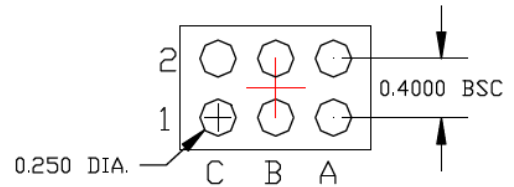

BOTTOM VIEW  
NOTE: 1, 2

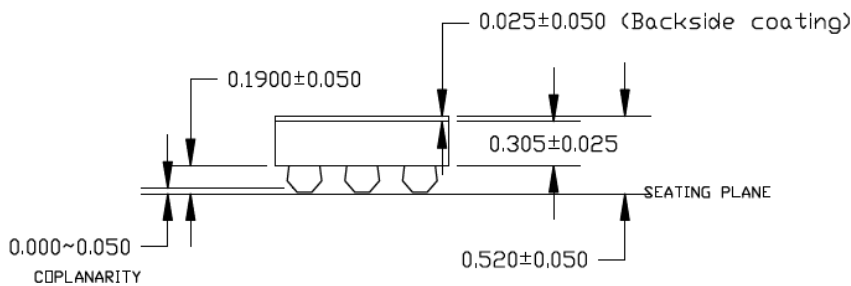

SIDE VIEW  
NOTE: 1, 2

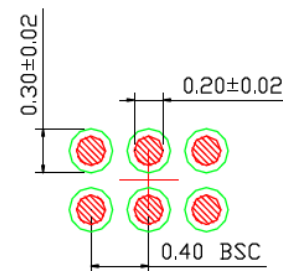

RECOMMENDED LAND PATTERN  
NOTE: 3, 4

**NOTE:**

1. MAX PACKAGE WARPAGE IS 0.05 MM
2. MAX ALLOWABLE BURR IS 0.076MM IN ALL DIRECTIONS
3. NON-SOLDERMASK DEFINED PADS ARE RECOMMENDED FOR BOARD LAYOUT
4. SHADED RED CIRCLES REPRESENT CONTACT PAD AREA. GREEN CIRCLES REPRESENT SOLDER MASK OPENING

Note: For the most current package drawings, please see the Microchip Packaging Specification located at <http://www.microchip.com/packaging>.

## Package Outlines and Dimensions

### TITLE

8 BALL WLCSP 2.11x1.11mm PACKAGE OUTLINE & RECOMMENDED LAND PATTERN

DRAWING #	WLCSP211111D-8BL-PL-9	UNIT	MM
-----------	-----------------------	------	----

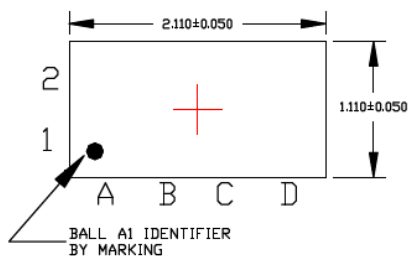

TOP VIEW

NOTE: 1,2

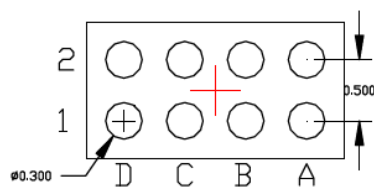

BOTTOM VIEW

NOTE: 1,2

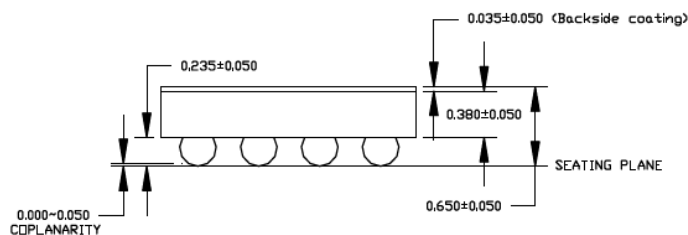

SIDE VIEW

NOTE: 1,2

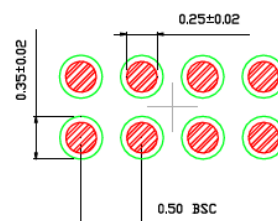

RECOMMENDED LAND PATTERN

NOTE: 3,4

### NOTE:

1. MAX PACKAGE WARPAGE IS 0.05 MM
2. MAX ALLOWABLE BURR IS 0.076MM IN ALL DIRECTIONS
3. NON-SOLDERMASK DEFINED PADS ARE RECOMMENDED FOR BOARD LAYOUT
4. SHADED RED CIRCLES REPRESENT CONTACT PAD AREA. GREEN CIRCLES REPRESENT SOLDER MASK OPENING

Note: For the most current package drawings, please see the Microchip Packaging Specification located at <http://www.microchip.com/packaging>.



## Package Outlines and Dimensions

**TITLE**

9 BALL WLCSP 1.3x1.3mm PACKAGE OUTLINE & RECOMMENDED LAND PATTERN

DRAWING #	WLCSP1313Q-9BL-PL-9	UNIT	MM
-----------	---------------------	------	----

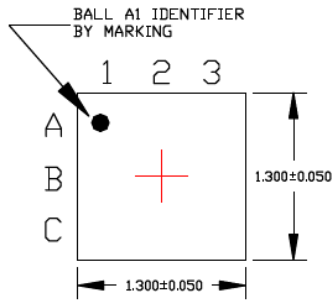

TOP VIEW  
NOTE: 1,2

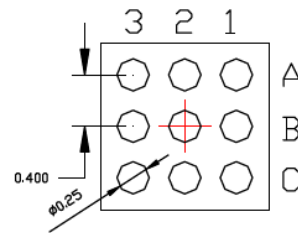

BOTTOM VIEW  
NOTE: 1,2

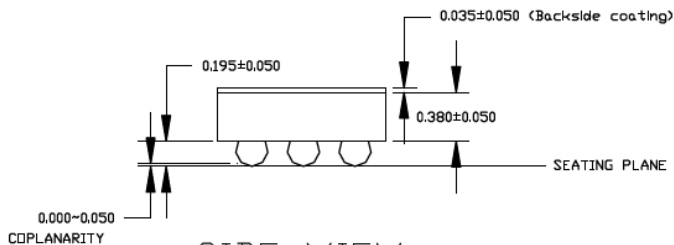

SIDE VIEW  
NOTE: 1,2

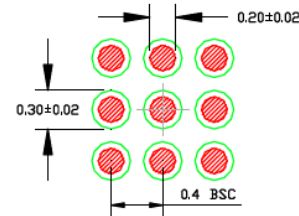

RECOMMENDED LAND PATTERN  
NOTE: 3,4

**NOTE:**

1. MAX PACKAGE WARPAGE IS 0.05 MM
2. MAX ALLOWABLE BURR IS 0.076MM IN ALL DIRECTIONS
3. NON-SOLDERMASK DEFINED PADS ARE RECOMMENDED FOR BOARD LAYOUT
4. SHADED RED CIRCLES REPRESENT CONTACT PAD AREA. GREEN CIRCLES REPRESENT SOLDER MASK OPENING

Note: For the most current package drawings, please see the Microchip Packaging Specification located at <http://www.microchip.com/packaging>.

## Package Outlines and Dimensions

**TITLE**

9 BALL WLCSP 1.67x1.77mm PACKAGE OUTLINE & RECOMMENDED LAND PATTERN

<b>DRAWING #</b>	WLCSP167177Q-9BL-PL-9	<b>UNIT</b>	MM
------------------	-----------------------	-------------	----

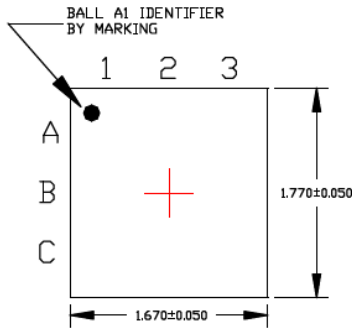

**TOP VIEW**  
NOTE: 1,2

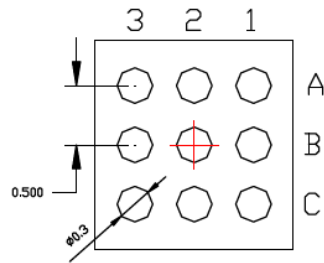

**BOTTOM VIEW**  
NOTE: 1,2

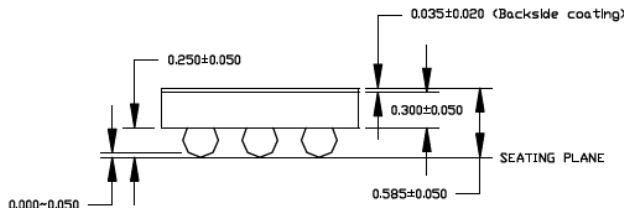

**SIDE VIEW**  
NOTE: 1,2

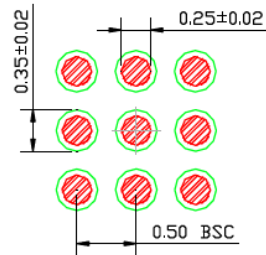

**RECOMMENDED LAND PATTERN**  
NOTE: 3,4

- NOTE:
1. MAX PACKAGE WARPAGE IS 0.05 MM
  2. MAX ALLOWABLE BURR IS 0.076MM IN ALL DIRECTIONS
  3. NON-SOLDERMASK DEFINED PADS ARE RECOMMENDED FOR BOARD LAYOUT
  4. SHADED RED CIRCLES REPRESENT CONTACT PAD AREA. GREEN CIRCLES REPRESENT SOLDER MASK OPENING

Note: For the most current package drawings, please see the Microchip Packaging Specification located at <http://www.microchip.com/packaging>.

## Package Outlines and Dimensions

**TITLE**

12 BALL WLCSP 1.31x1.71mm PACKAGE OUTLINE & RECOMMENDED LAND PATTERN

DRAWING #	WLCSP131171Q-12BL-PL-9	UNIT	MM
-----------	------------------------	------	----

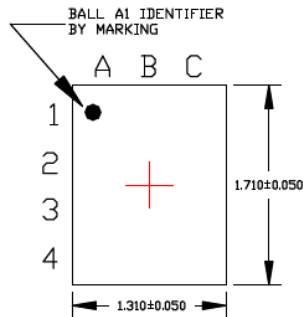

TOP VIEW

NOTE: 1,2

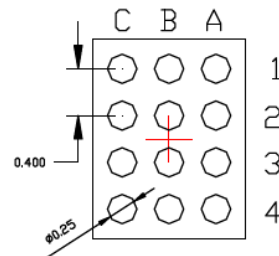

BOTTOM VIEW

NOTE: 1,2

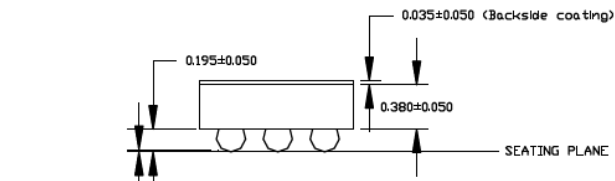

SIDE VIEW

NOTE: 1,2

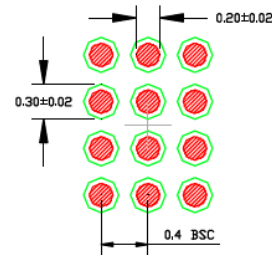

RECOMMENDED LAND PATTERN

NOTE: 3,4

**NOTE:**

1. MAX PACKAGE WARPAGE IS 0.05 MM
2. MAX ALLOWABLE BURR IS 0.076MM IN ALL DIRECTIONS
3. NON-SOLDERMASK DEFINED PADS ARE RECOMMENDED FOR BOARD LAYOUT
4. SHADED RED CIRCLES REPRESENT CONTACT PAD AREA. GREEN CIRCLES REPRESENT SOLDER MASK OPENING

Note: For the most current package drawings, please see the Microchip Packaging Specification located at <http://www.microchip.com/packaging>.

**Package Outlines and Dimensions**

**TITLE**

16 BALL WLCSP 1.81x1.71mm PACKAGE OUTLINE & RECOMMENDED LAND PATTERN

<b>DRAWING #</b>	WLCSP181171Q-16BL-PL-9	<b>UNIT</b>	MM
------------------	------------------------	-------------	----

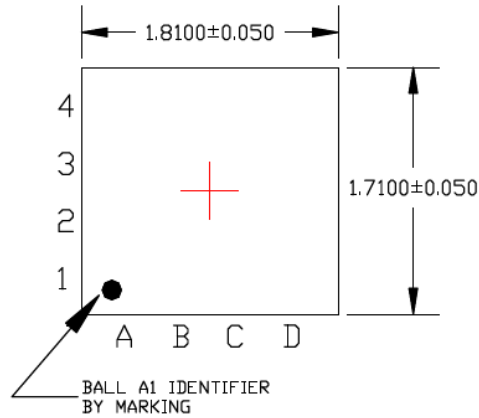

TOP VIEW  
NOTE: 1, 2

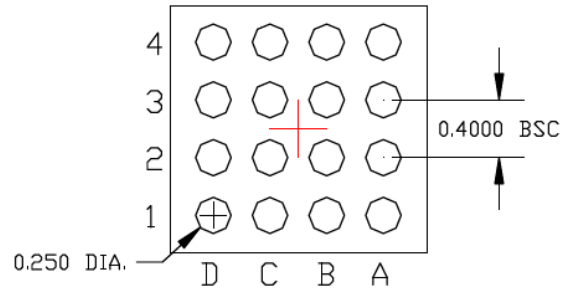

BOTTOM VIEW  
NOTE: 1, 2

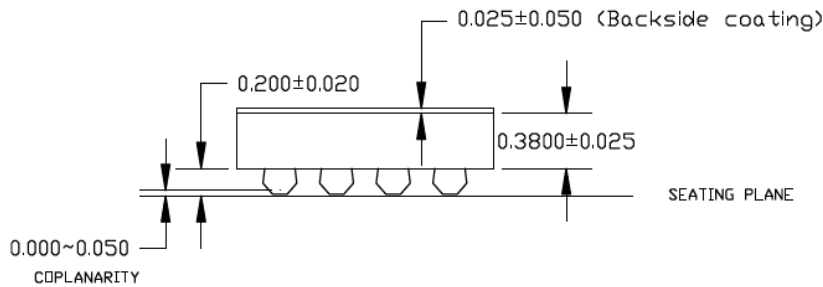

SIDE VIEW  
NOTE: 1, 2

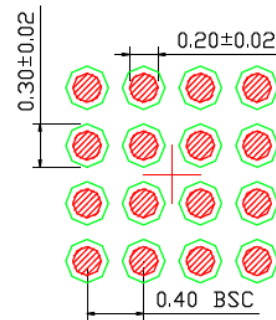

RECOMMENDED LAND PATTERN

NOTE: 3, 4

**NOTE:**

1. MAX PACKAGE WARPAGE IS 0.05 MM
2. MAX ALLOWABLE BURR IS 0.076MM IN ALL DIRECTIONS
3. NON-SOLDERMASK DEFINED PADS ARE RECOMMENDED FOR BOARD LAYOUT
4. SHADED RED CIRCLES REPRESENT CONTACT PAD AREA. GREEN CIRCLES REPRESENT SOLDER MASK OPENING

Note: For the most current package drawings, please see the Microchip Packaging Specification located at <http://www.microchip.com/packaging>.

**Package Outlines and Dimensions**

**TITLE**

16 BALL WLCSP 1.88x1.88mm PACKAGE OUTLINE & RECOMMENDED LAND PATTERN

<b>DRAWING #</b>	WLCSP188188Q-16BL-PL-9	<b>UNIT</b>	MM
------------------	------------------------	-------------	----

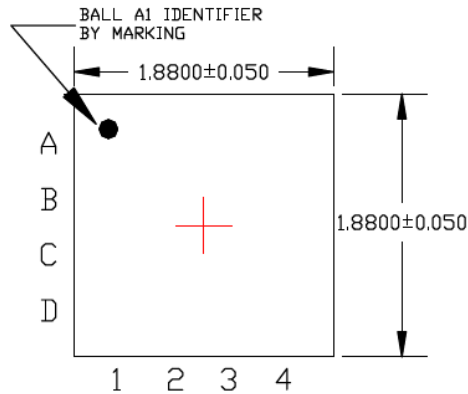

TOP VIEW  
NOTE: 1, 2

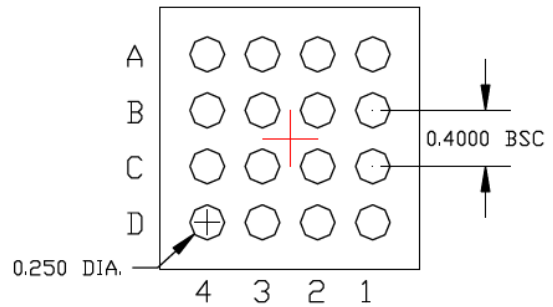

BOTTOM VIEW  
NOTE: 1, 2

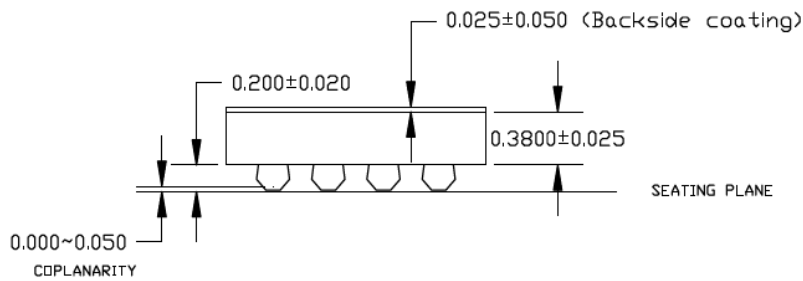

SIDE VIEW  
NOTE: 1, 2

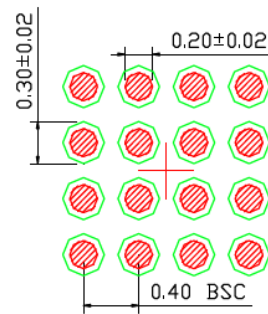

RECOMMENDED LAND PATTERN  
NOTE: 3, 4

**NOTE:**

1. MAX PACKAGE WARPAGE IS 0.05 MM
2. MAX ALLOWABLE BURR IS 0.076MM IN ALL DIRECTIONS
3. NON-SOLDERMASK DEFINED PADS ARE RECOMMENDED FOR BOARD LAYOUT
4. SHADED RED CIRCLES REPRESENT CONTACT PAD AREA. GREEN CIRCLES REPRESENT SOLDER MASK OPENING

Note: For the most current package drawings, please see the Microchip Packaging Specification located at <http://www.microchip.com/packaging>.

## Package Outlines and Dimensions

### TITLE

25 BALL WLCSF 2.07x2.26mm PACKAGE OUTLINE & RECOMMENDED LAND PATTERN

DRAWING #	WLCSF207226Q-16BL-PL-9	UNIT	MM
-----------	------------------------	------	----

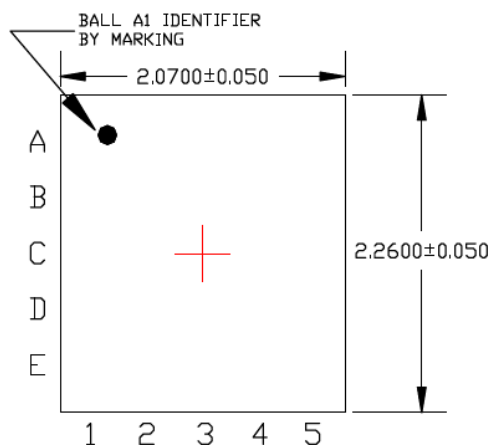

TOP VIEW

NOTE: 1, 2

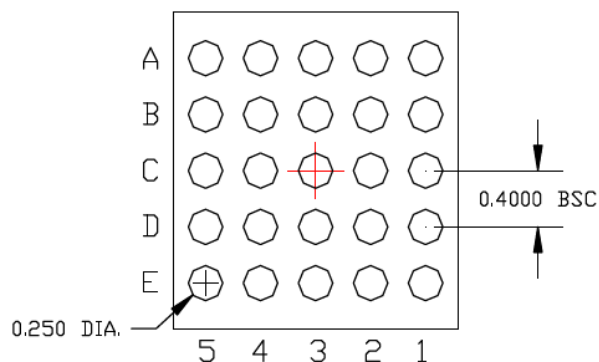

BOTTOM VIEW

NOTE: 1, 2

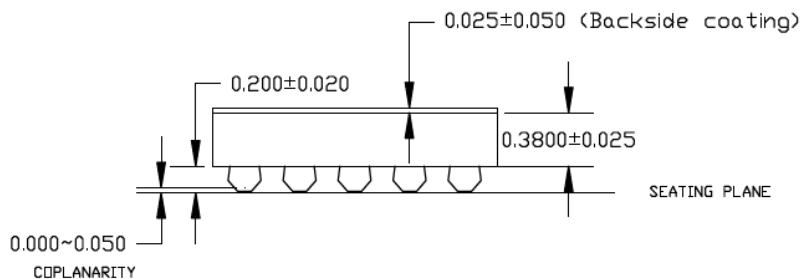

SIDE VIEW

NOTE: 1, 2

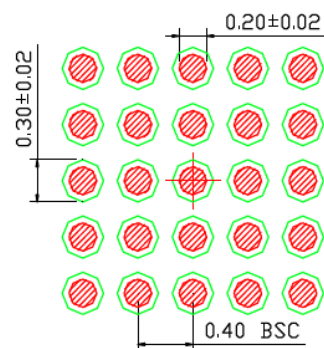

RECOMMENDED LAND PATTERN

NOTE: 3, 4

### NOTE:

1. MAX PACKAGE WARPAGE IS 0.05 MM
2. MAX ALLOWABLE BURR IS 0.076MM IN ALL DIRECTIONS
3. NON-SOLDERMASK DEFINED PADS ARE RECOMMENDED FOR BOARD LAYOUT
4. SHADED RED CIRCLES REPRESENT CONTACT PAD AREA. GREEN CIRCLES REPRESENT SOLDER MASK OPENING

Note: For the most current package drawings, please see the Microchip Packaging Specification located at <http://www.microchip.com/packaging>.

---

---

**Package Outlines and Dimensions**

---

---

**WQFN**

Micrel Legacy

## Package Outlines and Dimensions

### TITLE

32 LEAD WQFN 5x5mm PACKAGE (Wettable Flank) OUTLINE & RECOMMENDED LAND PATTERN

DRAWING #	WQFN55-32LD-PL-1	UNIT	MM
-----------	------------------	------	----

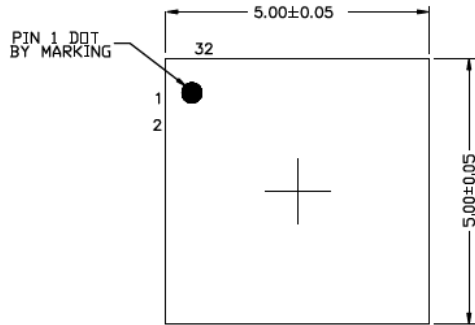

TOP VIEW  
NOTE: 1, 2, 3

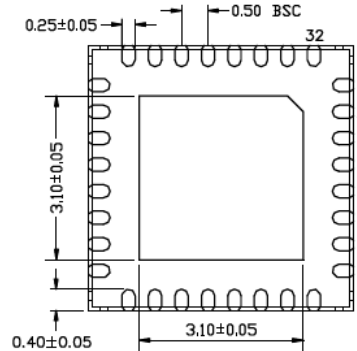

BOTTOM VIEW  
NOTE: 1, 2, 3

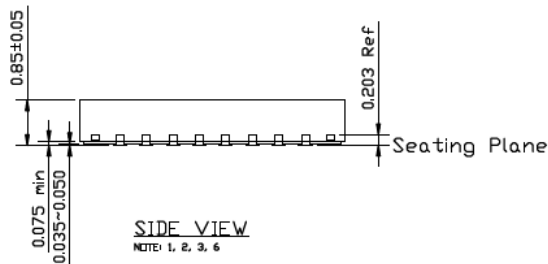

SIDE VIEW  
NOTE: 1, 2, 3, 6

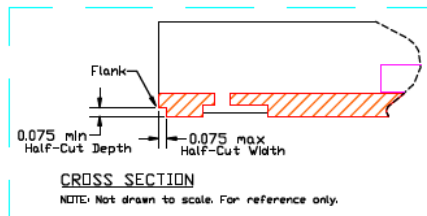

CROSS SECTION  
NOTE: Not drawn to scale. For reference only.

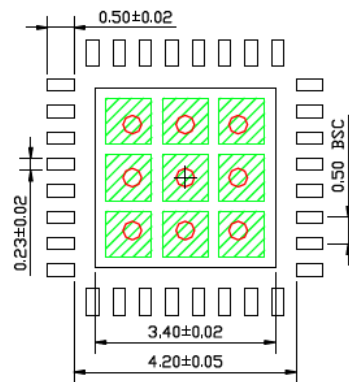

RECOMMENDED LAND PATTERN  
NOTE: 4, 5

### NOTE:

1. MAX PACKAGE WARPAGE IS 0.05mm.
2. MAX ALLOWABLE BURR IS 0.076mm IN ALL DIRECTIONS.
3. PIN #1 IS ON TOP WILL BE LASER MARKED.
4. RED CIRCLES IN LAND PATTERN INDICATES THERMAL VIA. SIZE SHOULD BE 0.30-0.35mm IN DIAMETER, 1.00mm PITCH & SHOULD BE CONNECTED TO GND FOR MAX THERMAL PERFORMANCE.
5. GREEN RECTANGLES (SHADED AREA) REPRESENT SOLDER STENCIL OPENING ON EXPOSED PAD AREA. RECOMMENDED SIZE IS 0.87x0.87mm, 1.07mm PITCH.
6. "W" IN WQFN IS WETTABLE FLANK PACKAGE.

Note: For the most current package drawings, please see the Microchip Packaging Specification located at <http://www.microchip.com/packaging>.



---



---

## Package Outlines and Dimensions

---



---

**TITLE**

48 LEAD WQFN 7x7mm PACKAGE (Wettable Flank) OUTLINE &amp; RECOMMENDED LAND PATTERN

DRAWING #	WQFN77-48LD-PL-1	UNIT	MM
-----------	------------------	------	----

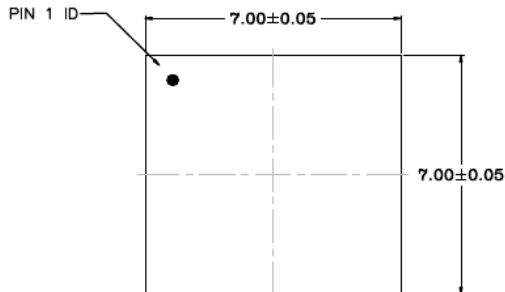

**TOP VIEW**  
NOTE: 1, 2, 3, 7

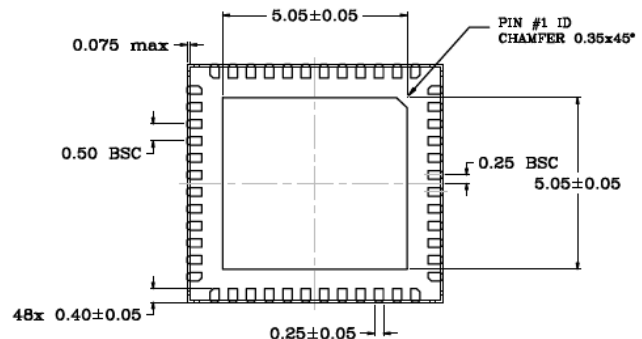

**BOTTOM VIEW**  
NOTE: 1, 2, 3, 7

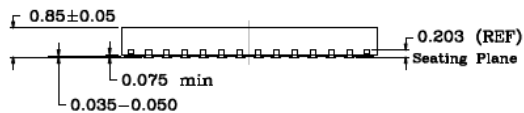

**SIDE VIEW**  
NOTE: 1, 2, 3, 7

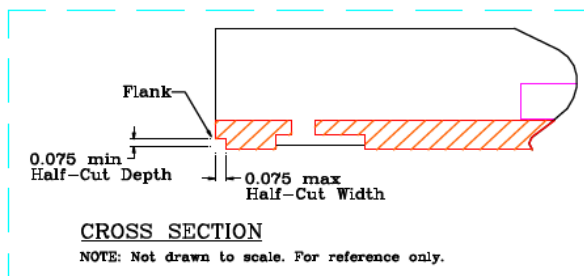

**CROSS SECTION**  
NOTE: Not drawn to scale. For reference only.

**NOTE:**

1. MAX PACKAGE WARPAGE IS 0.05mm.
2. MAX ALLOWABLE BURR IS 0.076mm IN ALL DIRECTIONS.
3. PIN #1 IS ON TOP WILL BE LASER MARKED.
4. RED CIRCLES IN LAND PATTERN INDICATES THERMAL VIA. SIZE SHOULD BE 0.30-0.35mm IN DIAMETER AND SHOULD BE CONNECTED TO GND FOR MAX THERMAL PERFORMANCE. PITCH = 1.00mm
5. GREEN RECTANGLES (SHADED AREA) REPRESENT SOLDER STENCIL OPENING ON EXPOSED PAD AREA. RECOMMENDED SIZE IS 1.0x1.0mm, SPACING = 0.25mm.
6. "W" IN WQFN IS WETTABLE FLANK PACKAGE.

Note: For the most current package drawings, please see the Microchip Packaging Specification located at <http://www.microchip.com/packageing>.

**Package Outlines and Dimensions**

POD-Land Pattern drawing #WQFN77-48LD-PL-1

**RECOMMENDED LAND PATTERN**

NOTE: 4, 5, 7

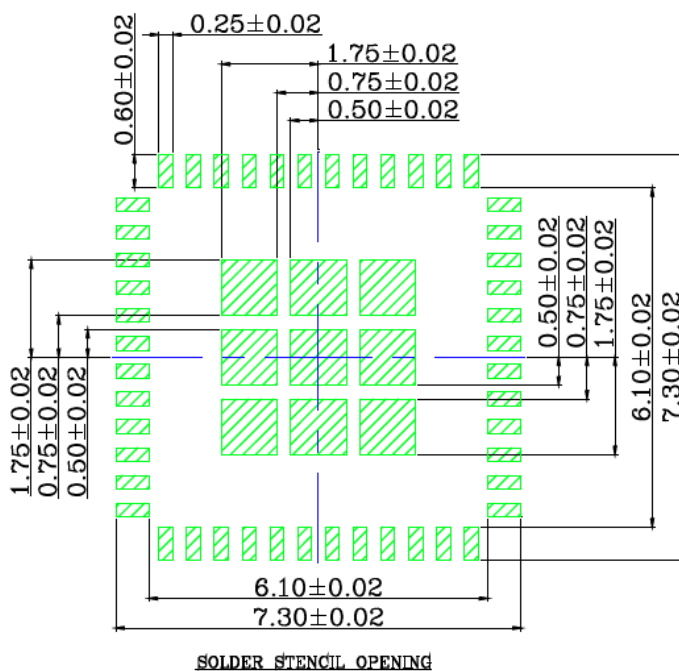
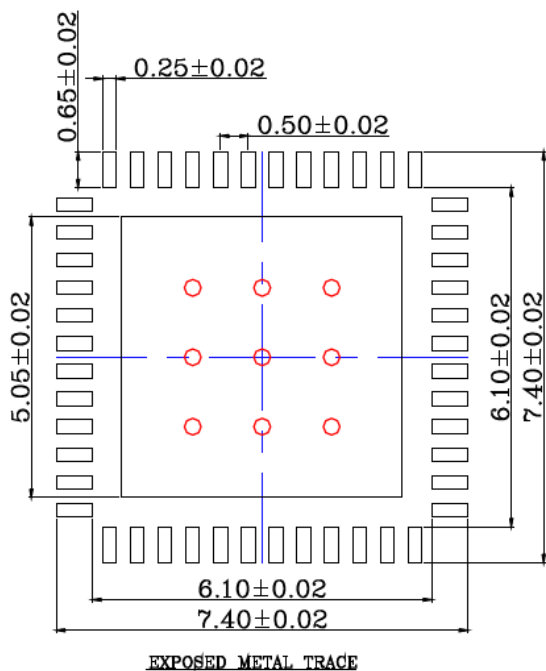
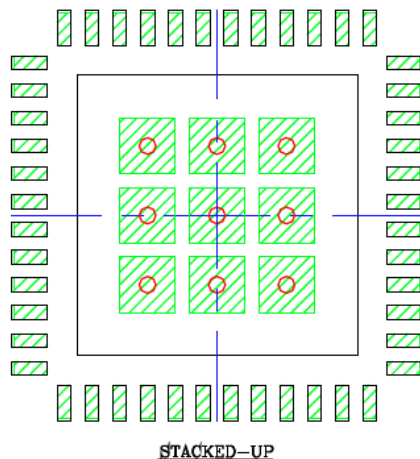

Note: For the most current package drawings, please see the Microchip Packaging Specification located at <http://www.microchip.com/packaging>.

---

---

**Package Outlines and Dimensions**

---

---

**XTDFN**

Micrel Legacy

**TITLE**

6 LEAD XTDFN 1.2x1.2mm PACKAGE OUTLINE & RECOMMENDED LAND PATTERN

<b>DRAWING #</b>	XTDFN1212-6LD-PL-1	<b>UNIT</b>	MM
<b>Lead Frame</b>	NiPdAu	<b>Lead Finish</b>	NiPdAu

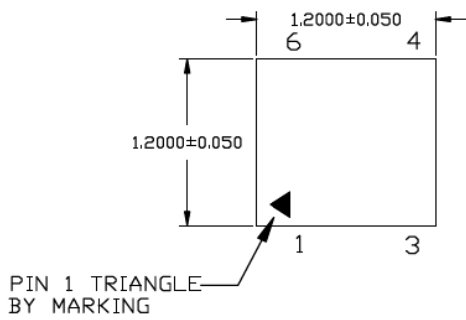

TOP VIEW  
NOTE: 1, 2

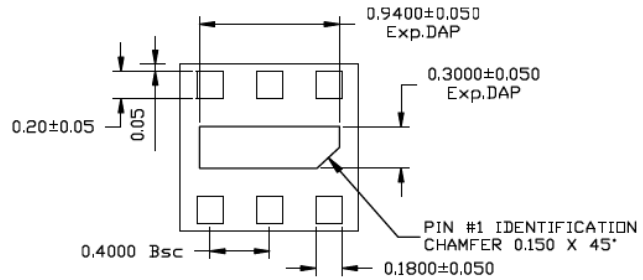

BOTTOM VIEW  
NOTE: 1, 2, 3

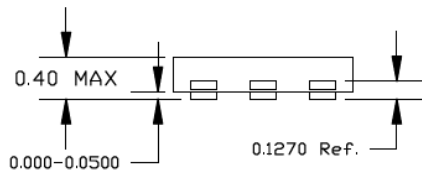

SIDE VIEW  
NOTE: 1, 2

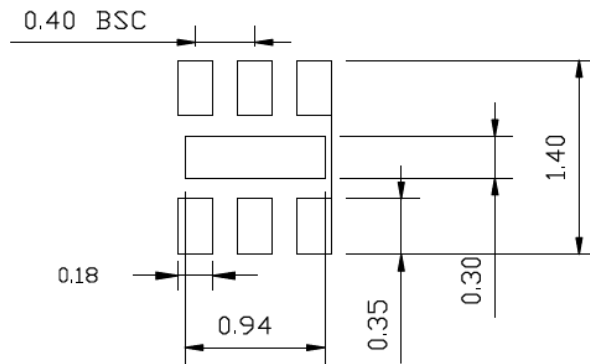

RECOMMENDED LAND PATTERN

**NOTE:**

1. MAX PACKAGE WARPAGE IS 0.05 MM
2. MAX ALLOWABLE BURR IS 0.076MM IN ALL DIRECTIONS
3. LEAD AND EPAD CORNER MAXIMUM RADIUS 0.075MM

Note: For the most current package drawings, please see the Microchip Packaging Specification located at <http://www.microchip.com/packaging>.

**XTDFN1612-8LD-PL-1-D.pdf Package Outlines and Dimensions**

**TITLE**

8 LEAD XTDFN 1.6x1.2mm PACKAGE OUTLINE & RECOMMENDED LAND PATTERN

<b>DRAWING #</b>	XTDFN1612-8LD-PL-1	<b>UNIT</b>	MM
<b>Lead Frame</b>	NiPdAu	<b>Lead Finish</b>	NiPdAu

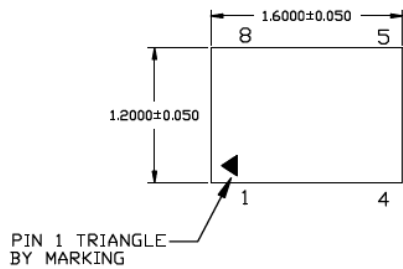

TOP VIEW  
NOTE: 1, 2

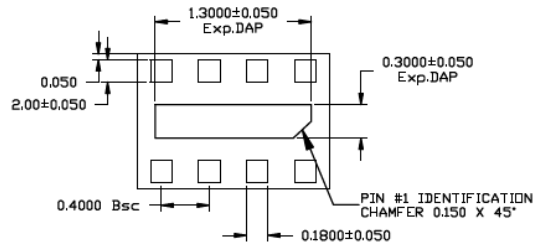

BOTTOM VIEW  
NOTE: 1, 2, 3

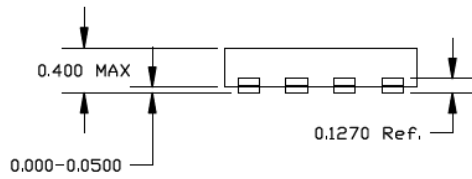

SIDE VIEW  
NOTE: 1, 2

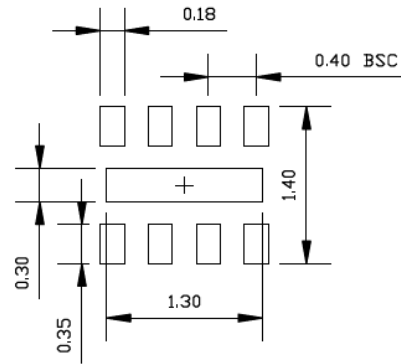

RECOMMENDED LAND PATTERN

- NOTE:
1. MAX PACKAGE WARPAGE IS 0.05 MM
  2. MAX ALLOWABLE BURR IS 0.076MM IN ALL DIRECTIONS
  3. LEAD AND EPAD CORNER MAXIMUM RADIUS 0.075MM

Note: For the most current package drawings, please see the Microchip Packaging Specification located at <http://www.microchip.com/packaging>.

**TITLE**

10 LEAD XTDFN 2.5x2.5mm PACKAGE OUTLINE & RECOMMENDED LAND PATTERN

DRAWING #	XTDFN2525-10LD-PL-1	UNIT	MM
-----------	---------------------	------	----

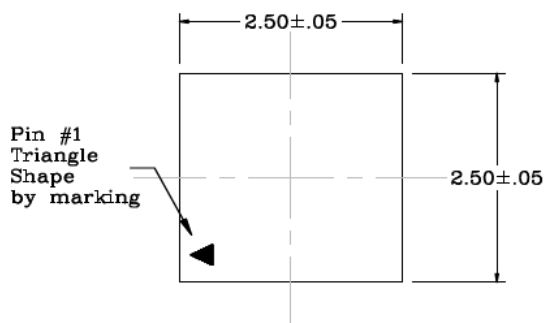

**TOP VIEW**  
NOTE: 1, 2

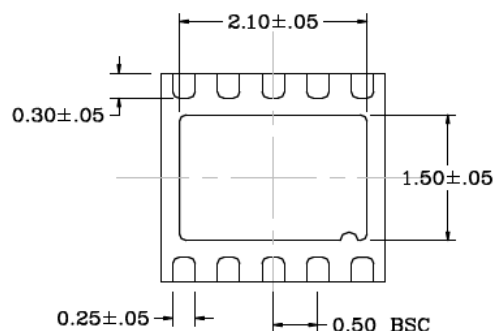

**BOTTOM VIEW**  
NOTE: 1, 2, 3

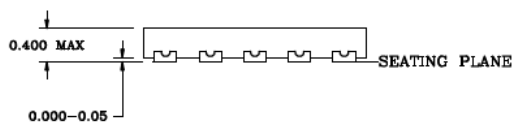

**SIDE VIEW**  
NOTE: 1, 2

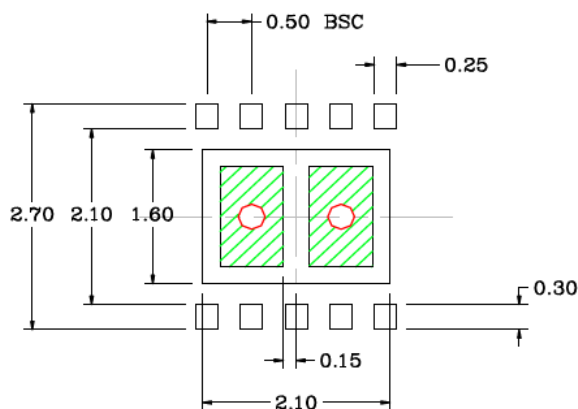

**RECOMMENDED LAND PATTERN**  
NOTE: 4, 5, 6

**NOTE:**

1. MAX PACKAGE WARPAGE IS 0.05mm
2. MAX ALLOWABLE BURR IS 0.076mm IN ALL DIRECTIONS.
3. LEAD AND EPAD CORNER MAXIMUM RADIUS 0.075mm.
4. GREEN RECTANGLES IN RECOMMENDED LAND PATTERN IS SOLDER STENCIL OPENING ON EXPOSED PAD AREA. SIZE IS 0.60mm X 0.90mm. SPACING IS 0.30mm.
5. RED CIRCLES IN LAND PATTERN ARE VIAS AND SHOULD BE CONNECTED TO GROUND FOR MAXIMUM PERFORMANCE. DIAMETER IS 0.30-0.35mm, PITCH IS 1.0mm.
6. RECOMMENDED LAND PATTERN TOLERANCE IS  $\pm 0.020$ mm UNLESS SPECIFIED.

Note: For the most current package drawings, please see the Microchip Packaging Specification located at <http://www.microchip.com/packaging>.

## APPENDIX A: REVISION HISTORY

### Revision AL (February 2007)

Packages were revised. Telcom package designators were added where the designators vary from Microchip designators.

Revised 3-Lead Plastic Transistor Outline (TO or ZB) [TO-92].

Revised 3-Lead Plastic Small Outline Transistor (TT or NB) [SOT-23].

Revised 3-Lead Plastic Small Outline Transistor (CB or NB) [SOT-23A].

Revised 3-Lead Plastic Small Outline Transistor (DB) [SOT-223].

Revised 5-Lead Plastic Small Outline Transistor (DB) [SOT-223].

Revised 4-Lead Plastic Small Outline Transistor (RC) [SOT-143].

Revised 5-Lead Plastic Small Outline Transistor (OT or CT) [SOT-23].

Revised 6-Lead Plastic Small Outline Transistor (CH) [SOT-23].

Revised 8-Lead Plastic Dual In-Line (P or PA) 300 mil Body [PDIP].

Revised 14-Lead Plastic Dual In-Line (P or PD) 300 mil Body [PDIP].

Revised 16-Lead Plastic Dual In-Line (P or PE) 300 mil Body [PDIP].

Revised 24-Lead Plastic Dual In-Line (P or PG) 600 mil Body [PDIP].

Revised 24-Lead Skinny Plastic Dual In-Line (SP or PF) 300 mil Body [SPDIP].

Revised 28-Lead Skinny Plastic Dual In-Line (SP or PJ) 300 mil Body [SPDIP].

Revised 28-Lead Plastic Dual In-Line (P or PI) 600 mil Body [PDIP].

Revised 40-Lead Plastic Dual In-Line (P or PL) 600 mil Body [PDIP].

Revised 20-Lead Plastic Leaded Chip Carrier (L) Square [PLCC].

Revised 28-Lead Plastic Leaded Chip Carrier (L or LI) Square [PLCC].

Revised 32-Lead Plastic Leaded Chip Carrier (L) Rectangle [PLCC].

Revised 44-Lead Plastic Leaded Chip Carrier (L or LW) Square [PLCC].

Revised 68-Lead Plastic Leaded Chip Carrier (L or LS) Square [PLCC].

Revised 84-Lead Plastic Leaded Chip Carrier (L) Square [PLCC].

Revised 8-Lead Plastic Small Outline (SN or OA) Narrow, 3.90 mm Body [SOIC].

Revised 14-Lead Plastic Small Outline (SL or OD) Narrow, 3.90 mm Body [SOIC].

Revised 16-Lead Plastic Small Outline (SL) Narrow, 3.90 mm Body [SOIC].

Revised 8-Lead Plastic Small Outline (SM) Medium, 5.28 mm Body [SOIJ].

Revised 16-Lead Plastic Small Outline (SO or OE) Wide, 7.50 mm Body [SOIC].

Revised 18-Lead Plastic Small Outline (SO) Wide, 7.50 mm Body [SOIC].

Revised 20-Lead Plastic Small Outline (SO) Wide, 7.50 mm Body [SOIC].

Revised 24-Lead Plastic Small Outline (SO or PF) Wide, 7.50 mm Body [SOIC].

Revised 28-Lead Plastic Small Outline (SO or OI) Wide, 7.50 mm Body [SOIC].

Revised 8-Lead Plastic Micro Small Outline Package (MS or UA) [MSOP].

Revised 10-Lead Plastic Micro Small Outline Package (MS or UN) [MSOP].

Revised 16-Lead Plastic Shrink Small Outline Narrow Body (QR).150" Body [QSOP].

Revised 64-Lead Plastic Metric Quad Flatpack (KU) 14x14x2.7 mm Body, 3.20 mm Footprint [MQFP].

Revised 44-Lead Plastic Metric Quad Flatpack (KW) 10x10x2.0 mm Body, 3.9 mm Footprint [PQFP].

### Revision AM (March 2007)

**Four Microchip and Telcom package designators were corrected and one package was removed.**

Revised 6-Lead Plastic Small Outline Transistor (CH) [SOT-23] to (CH or OT).

Revised 3-Lead Plastic Small Outline Transistor (CB or NB) [SOT-23A] to (CB) .

Revised 44-Lead Plastic Metric Quad Flatpack (PQ) [MQFP] to (PQ or KW).

Revised 64-Lead Plastic Metric Quad Flatpack (KU) [MQFP] to (BU).

Deleted 44-Lead Plastic Metric Quad Flatpack (KW) – 10x10x2.0 mm Body, 3.9 mm Footprint [PQFP].

# PACKAGING SPECIFICATION

---

## Revision AN (March 2007)

16-Lead Plastic Shrink Small Outline Narrow Body (QR) .150" Body [QSOP]: the nominal pitch value for the package is corrected to ".025." This correction revises MCHP Drawing C04-024B to C04-024C.

**Packages with a Microchip and a Telcom designator are represented on separate pages, rather than having both designators on a single page.**

## Revision AP (April 2007)

Revised 40-Lead Ceramic Dual In-Line with Window (JW) .600" Body [CERDIP]. The E-1 MAX dimension has changed from ".540" to ".583". This correction revises MCHP Drawing C04-014B to C04-014C.

## Revision AQ (July 2007)

Revised 5-Lead Plastic Small Outline Transistor [SOT-223] package designator from (DB) to (DC). This correction revises MCHP Drawing C04-137A to C04-137B.

## Revision AR (September 2007)

**Land patterns have been added for the following 13 packages:**

8-Lead Plastic Small Outline (SN) – Narrow, 3.90 mm Body [SOIC].

28-Lead Plastic Quad Flat, No Lead Package (ML) – 6x6 mm Body [QFN] with 0.55 mm Contact Length.

28-Lead Plastic Quad Flat, No Lead Package (MM) – 6x6x0.9 mm Body [QFN-S] with 0.40 mm Contact Length.

44-Lead Plastic Quad Flat, No Lead Package (ML) – 8x8 mm Body [QFN].

44-Lead Plastic Metric Quad Flatpack (PQ) – 10x10x2 mm Body, 3.20 mm [MQFP].

64-Lead Plastic Metric Quad Flatpack (BU) – 14x14x2.7 mm Body, 3.20 mm [MQFP].

44-Lead Plastic Thin Quad Flatpack (PT) – 10x10x1 mm Body, 2.00 mm [TQFP].

64-Lead Plastic Thin Quad Flatpack (PT) – 10x10x1 mm Body, 2.00 mm [TQFP].

64-Lead Plastic Thin Quad Flatpack (PF) – 14x14x1 mm Body, 2.00 mm [TQFP].

80-Lead Plastic Thin Quad Flatpack (PT) – 12x12x1 mm Body, 2.00 mm [TQFP].

80-Lead Plastic Thin Quad Flatpack (PF) – 14x14x1 mm Body, 2.00 mm [TQFP].

100-Lead Plastic Thin Quad Flatpack (PT) – 12x12x1 mm Body, 2.00 mm [TQFP].

100-Lead Plastic Thin Quad Flatpack (PF) – 14x14x1 mm Body, 2.00 mm [TQFP].

## Revision AS (January 2008)

**The following packages are new:**

Drawing 0129B, 8-Lead Plastic Dual Flat, No Lead Package (MN) - 2x3x0.75 mm Body [TDFN] on page 156.

Drawing 136B, 8-Lead Plastic Dual Flat, No Lead Package (MU) - 2x3x0.5 mm Body [UDFN] on page 158.

Land patterns have been added for the following packages:

Drawing 2032A, 3-Lead Plastic Small Outline Transistor (DB) Footprint [SOT-223] on page 33.

Drawing 2137A, 5-Lead Plastic Small Outline Transistor (DC) Footprint [SOT-223] on page 35.

Drawing 2031A, 4-Lead Plastic Small Outline Transistor (RC) Footprint [SOT-143] on page 37.

Drawing 2057A, 8-Lead Plastic Small Outline (SN) Narrow, 3.90 mm Body Footprint [SOIC] on page 79.

Drawing 2057A, 8-Lead Plastic Small Outline (OA) Narrow, 3.90 mm Body Footprint [SOIC] on page 81.

Drawing 2056A, 8-Lead Plastic Small Outline (SM) Medium, 5.28 mm Body Footprint [SOIJ] on page 86.

Drawing 2123A, 8-Lead Plastic Dual Flat, No Lead Package (MC) 2x3x0.9 mm Body Footprint [DFN] on page 99.

Drawing 2062A, 8-Lead Plastic Dual Flat, No Lead Package (MF) - 3x3x0.9 mm Body Footprint [DFN] on page 103.

Drawing 2131A, 8-Lead Plastic Dual Flat, No Lead Package (MD) 4x4x0.9 mm Body Footprint [DFN] on page 105.

Drawing 2063A, 10-Lead Plastic Dual Flat, No Lead Package (MF) 3x3x0.9 mm Body Footprint [DFN] on page 109.

Drawing 2129A, 8-Lead Plastic Dual Flat, No Lead Package (MN) - 2x3x0.75 mm Body Footprint [TDFN] on page 157.

Drawing 2136A, 8-Lead Plastic Dual Flat, No Lead Package (MU) - 2x3x0.5 mm Body Footprint [UDFN] on page 159.

**Corrections have been made to the following packages:**

Drawing 123C, 8-Lead Plastic Dual Flat, No Lead Package (MC) 2x3x0.9 mm Body [DFN] on page 98.

Drawing 131D, 8-Lead Plastic Dual Flat, No Lead Package (MD) 4x4x0.9 mm Body [DFN] on page 104.

Drawing 2116A, 80-Lead Plastic Thin Quad Flatpack (PF) 14x14x1 mm Body, 2.00 mm Footprint [TQFP] on page 151.

## Revision AT (June 2008)

Revised 24-Lead Plastic Small Outline [SOIC], Wide, 7.50 mm Body package designator from (PF) to (OG) on page 104.



# PACKAGING SPECIFICATION

---

## The following packages are new:

Drawing 0143A, 24-Lead Plastic Quad Flat, No Lead Package (MJ) 4x4 mm Body [QFN] on page 130.

Drawing 0144A, 28-Lead Plastic Quad Flat, No Lead Package (MK) 4x4 mm Body [QFN] on page 132.

Drawing 0140A, 28-Lead Plastic Quad Flat, No Lead Package (MQ) 5x5 mm Body [QFN] on page 134.

Drawing 0145A, 8-Lead Chip Scale Package (CS) 3x2x3 Ball Pattern [CSP] on page 182.

Land patterns have been added for the following packages:

Drawing 2060A, 3-Lead Plastic Small Outline Transistor (LB) Footprint [SC70] on page 43.

Drawing 2061A, 5-Lead Plastic Small Outline Transistor (LT) Footprint [SC70] on page 45.

Drawing 2015A, 7-Lead Plastic (EK) Footprint [DDPAK] on page 51.

Drawing 2065A, 14-Lead Plastic Small Outline (SL) Narrow, 3.90 mm Body Footprint [SOIC] on page 89.

Drawing 2065A, 14-Lead Plastic Small Outline (OD) Narrow, 3.90 mm Body Footprint [SOIC] on page 91.

Drawing 2108A, 16-Lead Plastic Small Outline (SL) Narrow, 3.90 mm Body Footprint [SOIC] on page 93.

Drawing 2102A, 16-Lead Plastic Small Outline (SO) Wide, 7.50 mm Body Footprint [SOIC] on page 97.

Drawing 2102A, 16-Lead Plastic Small Outline (OE) Wide, 7.50 mm Body Footprint [SOIC] on page 99.

Drawing 2051A, 18-Lead Plastic Small Outline (SO) Wide, 7.50 mm Body Footprint [SOIC] on page 101.

Drawing 2122A, 8-Lead Plastic Dual Flat, No Lead Package (MF) 6x5 mm Body Footprint [DFN-S] on page 119.

Drawing 2127A, 16-Lead Plastic Quad Flat, No Lead Package (ML) 4x4x0.9 mm Body Footprint [QFN] on page 127.

Drawing 2126A, 20-Lead Plastic Quad Flat, No Lead Package (ML) 4x4x0.9 mm Body Footprint [QFN] on page 129.

Drawing 2143A, 24-Lead Plastic Quad Flat, No Lead Package (MJ) 4x4 mm Body Footprint [QFN] on page 131.

Drawing 2144A, 28-Lead Plastic Quad Flat, No Lead Package (MK) 4x4 mm Body Footprint [QFN] on page 133.

Drawing 2140A, 28-Lead Plastic Quad Flat, No Lead Package (MQ) 5x5 mm Body Footprint [QFN] on page 135.

## Revision AU (June 2008)

Updated 8-Lead Plastic Small Outline (SM) Medium 5.28 mm Body Footprint [SOIJ] on page 95.

## Revision AV (September 2008)

Added Drawing 0139A, 20-Lead Plastic Quad Flat, No Lead Package (MQ) 5x5x0.9 mm Body [QFN] on page 124.

## Revision AW (October 2008)

Revised 40-Lead Plastic Quad Flat, No Lead Package (MM) 6x6x0.9 mm Body [QFN] on page 136, correcting the package designator from (MM) to (ML).

## Revision AX (January 2009)

Added Drawing 149A, 64-Lead Plastic Quad Flat, No Lead Package (ML) 6x6x0.9 mm Body [QFN] on page 140. This package is presented on 2 pages to facilitate a more explicit specification through the addition of geometric dimensioning and tolerancing (GD&T) information. GD&T symbols and rules are described and defined in the ASME Y14.5M-1994 standard ([www.asme.org](http://www.asme.org)).

## Revision AY (March 2009)

Revised Drawing 0131E, 8-Lead Plastic Dual Flat, No Lead Package (MD) 4x4x0.9 mm Body [DFN] to the new two-page format. It is shown on pages 115-116.

Also revised Drawing 149B, 64-Lead Plastic Quad Flat No Lead Package (MR) 9x9x0.9 mm Body [QFN] on pages 147-148. A corresponding land pattern (2149A), in the list below, was added.

## The following packages are new:

Drawing 151A, 6-Lead Plastic Small Outline Transistor (LT) [SC70] on pages 45-46.

Drawing 2151A, 6-Lead Plastic Small Outline Transistor (LT) Footprint [SC70] on page 47.

Drawing 2149A, 64-Lead Plastic Quad Flat, No Lead Package (MR) 9x9x0.9 mm Body Footprint [QFN] on page 149.

Drawing 068A, 16-Lead Plastic Thin Shrink Small Outline (ST) 4.4 mm Body [TSSOP] on page 161-162.

Drawing 2068A, 16-Lead Plastic Thin Shrink Small Outline (ST) 4.4 mm Body Footprint [TSSOP] on page 163.

Drawing 6005A, 4-Lead Chip Scale Package (CS) 2x2 Ball Pattern [CSP] on pages 191-192.

Drawing 8005A, 4-Lead Chip Scale Package (CS) 2x2 Ball Pattern Footprint [CSP] on page 193.

Drawing 6004A, 5-Lead Chip Scale Package (CS) 2x1x2 Ball Pattern [CSP] on pages 195-196.

Drawing 8004A, 5-Lead Chip Scale Package (CS) 2x1x2 Ball Pattern Footprint [CSP] on page 197.

Drawing 6001A, 8-Lead Chip Scale Package (CS) 3x2x3 Ball Pattern [CSP] on pages 199-200. This package was designated Drawing 145A in the last version of the packaging specification (00049AX).

# PACKAGING SPECIFICATION

---

Drawing 8001A, 8-Lead Chip Scale Package (CS) 3x2x3 Ball Pattern Footprint [CSP] on page 201.

Drawing 6003A, 20-Lead Chip Scale Package (CS) 4x5 Special Array Pattern [CSP] on pages 203-204.

Drawing 8003A, 20-Lead Chip Scale Package (CS) 4x5 Special Array Pattern Footprint [CSP] on page 205.

Drawing 6002A, 28-Lead Chip Scale Package (CS) 7-6-7-6-7 [CSP] on pages 207-208.

Drawing 8002A, 28-Lead Chip Scale Package (CS) 7-6-7-6-7 Footprint [CSP] on page 209.

Appendix B: Control Dimensions (inspection information) on page 217.

## Revision AZ (April 2009)

### The following drawings were removed:

Drawing 6003A, 20-Lead Chip Scale Package (CS) 4x5 Special Array Pattern [CSP] on pages 203-204.

Drawing 8003A, 20-Lead Chip Scale Package (CS) 4x5 Special Array Pattern Footprint [CSP] on page 205.

Drawing 6002A, 28-Lead Chip Scale Package (CS) 7-6-7-6-7 [CSP] on pages 207-208.

Drawing 8002A, 28-Lead Chip Scale Package (CS) 7-6-7-6-7 Footprint [CSP] on page 209.

Appendix B: "Control Dimensions" was modified to include the item "Foot Angle" under B.1 "On Surface Mount Devices (SMD)" on page 549.

## Revision BA (April 2009)

### The following drawing is new:

Drawing 142A, 16-Lead Plastic Quad Flat, No Lead Package (MG) 3x3x0.9 mm Body [QFN] on pages 126-127.

### The following drawing was corrected:

Drawing 2051A, 18-Lead Plastic Small Outline (SO) Wide, 7.50 mm Body Footprint [SOIC] on page 99. The second page of this drawing was incorrectly labeled as Drawing 2015A.

**Note 4 on the following drawings has been modified to refer interested parties to a Microchip representative, instead of a data sheet, for details about the package:**

Drawing 6005A, 4-Lead Chip Scale Package (CS) 2x2 Ball Pattern [CSP] on page 194.

Drawing 6004A, 5-Lead Chip Scale Package (CS) 2x1x2 Ball Pattern [CSP] on page 198.

Drawing 6001A, 8-Lead Chip Scale Package (CS) 3x2x3 Ball Pattern [CSP] on page 202.

## Revision BB (August 2009)

### The following drawings are new:

Drawing 0154A, 64-Lead Plastic Quad Flat, No Lead Package (MR) 9x9x0.9 mm Body with 5.40x5.40 Exp. Pad [QFN] on pages 152-153.

Drawing 0152A, 28-Lead Plastic Ultra Thin Quad Flat, No Lead Package (MV) 4x4x0.5 mm Body [UQFN] on pages 154-155.

Drawing 2111A, 8-Lead Plastic Micro Small Outline Package (MS) Footprint [MSOP] on page 157.

Drawing 2021A, 10-Lead Plastic Micro Small Outline Package (MS) Footprint [MSOP] on page 161.

Drawing 2086A, 8-Lead Plastic Thin Shrink Small Outline (ST) 4.4 mm Body Footprint [TSSOP] on page 169.

Drawing 2087A, 14-Lead Plastic Thin Shrink Small Outline (ST) 4.4 mm Body Footprint [TSSOP] on page 171.

Drawing 2088A, 20-Lead Plastic Thin Shrink Small Outline (ST) 4.4 mm Body Footprint [TSSOP] on page 177.

Drawing 148A, 121-Lead Plastic Thin Profile Ball Grid Array (BG) 10x10x1.10 mm Body [XBGA] on pages 216-217.

## Revision BC (January 2010)

### The following drawings are new or corrected:

Drawing 2097A, 68-Lead Ceramic Leaded (CL) Chip Carrier w/Window Square Footprint [CERQUAD] on page 31.

Drawing 2112A, 84-Lead Ceramic Leaded (CL) Chip Carrier w/Window Square Footprint [CERQUAD] on page 33.

Drawing 2104A, 3-Lead Plastic Small Outline Transistor (NB) Footprint [SOT-23] on page 44.

Drawing 2104A, 3-Lead Plastic Small Outline Transistor (TT) Footprint [SOT-23] on page 46.

Drawing 2091A, 5-Lead Plastic Small Outline Transistor (CT) Footprint [SOT-23] on page 48.

Drawing 2091A, 5-Lead Plastic Small Outline Transistor (OT) Footprint [SOT-23] on page 50.

Drawing 2028A, 6-Lead Plastic Small Outline Transistor (CH) Footprint [SOT-23] on page 52.

Drawing 2028A, 6-Lead Plastic Small Outline Transistor (OT) Footprint [SOT-23] on page 54.

Drawing 2130A, 3-Lead Plastic Small Outline Transistor (CB) Footprint [SOT-23A] on page 56.

Drawing 2029A, 3-Lead Plastic Small Outline Transistor Header (MB) Footprint [SOT-89] on page 58.

Drawing 2030A, 5-Lead Plastic Small Outline Transistor Header (MT) Footprint [SOT-89] on page 60.

Drawing 2128A, 5-Lead Plastic Thin Small Outline Transistor (OS) Footprint [TSOT] on page 73.

# PACKAGING SPECIFICATION

---

Drawing 2011A, 3-Lead Plastic (EB) Footprint [DDPAK] on page 77.

Drawing 2012A, 5-Lead Plastic (ET) Footprint [DDPAK] on page 79.

Drawing 2064A, 20-Lead Plastic Leaded Chip Carrier (L) Square Footprint [PLCC] on page 105.

Drawing 2026A, 28-Lead Plastic Leaded Chip Carrier (L) Square Footprint [PLCC] on page 107.

Drawing 2026A, 28-Lead Plastic Leaded Chip Carrier (LI) Square Footprint [PLCC] on page 109.

Drawing 2023A, 32-Lead Plastic Leaded Chip Carrier (L) Rectangle Footprint [PLCC] on page 111.

Drawing 2048A, 44-Lead Plastic Leaded Chip Carrier (L) Square Footprint [PLCC] on page 113.

Drawing 2048A, 44-Lead Plastic Leaded Chip Carrier (LW) Square Footprint [PLCC] on page 115.

Drawing 2049A, 68-Lead Plastic Leaded Chip Carrier (L) Square Footprint [PLCC] on page 117.

Drawing 2049A, 68-Lead Plastic Leaded Chip Carrier (LS) Square Footprint [PLCC] on page 119.

Drawing 2093A, 84-Lead Plastic Leaded Chip Carrier (L) Square Footprint [PLCC] on page 121.

Drawing 056C, 8-Lead Plastic Small Outline (SM) Medium, 5.28 mm Body [SOIJ] on pages 134-135.

Drawing 2094A, 20-Lead Plastic Small Outline (SO) Wide, 7.50 mm Body Footprint [SOIC] on page 144.

Drawing 2025A, 24-Lead Plastic Small Outline (OG) Wide, 7.50 mm Body Footprint [SOIC] on page 146.

Drawing 2025A, 24-Lead Plastic Small Outline (SO) Wide, 7.50 mm Body Footprint [SOIC] on page 148.

Drawing 2052A, 28-Lead Plastic Small Outline (OI) Wide, 7.50 mm Body Footprint [SOIC] on page 150.

Drawing 2052A, 28-Lead Plastic Small Outline (SO) Wide, 7.50 mm Body Footprint [SOIC] on page 152.

Drawing 062C, 8-Lead Plastic Dual Flat, No Lead Package (MF) 3x3x0.9 mm Body [DFN] on pages 159-160.

Drawing 2131C, 8-Lead Plastic Dual Flat, No Lead Package (MD) 4x4x0.9 mm Body Footprint [DFN] on page 164.

Drawing 0129C, 8-Lead Plastic Dual Flat, No Lead Package (MN) - 2x3x0.75 mm Body [TDFN] on pages 168-169.

Drawing 2142A, 16-Lead Plastic Quad Flat, No Lead Package (MG) 3x3x0.9 mm Body Footprint [QFN] on page 177.

Drawing 2139A, 20-Lead Plastic Quad Flat, No Lead Package (MQ) 5x5x0.9 mm Body Footprint [QFN] on page 183.

Drawing 118D, 40-Lead Plastic Quad Flat, No Lead Package (ML) 6x6x0.9 mm Body [QFN] on pages 194-195.

Drawing 2118A, 40-Lead Plastic Quad Flat, No Lead Package (ML) 6x6x0.9 mm Body Footprint [QFN] on page 196.

Drawing 2111A, 8-Lead Plastic Micro Small Outline Package (UA) Footprint [MSOP] on page 211.

Drawing 2021A, 10-Lead Plastic Micro Small Outline Package (UN) Footprint [MSOP] on page 215.

Drawing 2024A, 16-Lead Plastic Shrink Small Outline Narrow Body (QR) .150" Body Footprint [QSOP] on page 217.

Drawing 2072A, 20-Lead Plastic Shrink Small Outline (SS) 5.30 mm Body Footprint [SSOP] on page 221.

Drawing 2132A, 24-Lead Plastic Shrink Small Outline (SS) 5.30 mm Body Footprint [SSOP] on page 223.

Drawing 2073A, 28-Lead Plastic Shrink Small Outline (SS) 5.30 mm Body Footprint [SSOP] on page 225.

Drawing 2086A, 8-Lead Plastic Thin Shrink Small Outline (ST) 4.4 mm Body Footprint [TSSOP] on page 229.

Drawing 044A, 144-Lead Plastic Low Profile Quad Flatpack (PL) 20x20x1.40 mm Body, 2.0 mm [LQFP] on pages 243-244.

Drawing 2044A, 144-Lead Plastic Low Profile Quad Flatpack (PL) 20x20x1.40 mm Body, 2.0 mm Footprint [LQFP] on page 245.

Drawing 2071A, 44-Lead Plastic Metric Quad Flatpack (KW) 10x10x2 mm Body, 3.20 mm Footprint [MQFP] on page 249.

Drawing 2074A, 32-Lead Plastic Thin Quad Flatpack (PT) 7x7x1.0 mm Body, 2.00 mm Footprint [TQFP] on page 257.

Drawing 155A, 144-Lead Plastic Thin Quad Flatpack (PH) 16x16x1 mm Body, 2.00 mm [TQFP] on pages 272-273.

Drawing 2155A, 144-Lead Plastic Thin Quad Flatpack (PH) 16x16x1 mm Body, 2.00 mm Footprint [TQFP] on page 274.

Drawing 6005D, 4-Lead Chip Scale Package (CS) 2x2 Ball Pattern [CSP] on pages 276-277.

Drawing 8005A, 4-Lead Chip Scale Package (CS) 2x2 Ball Pattern Footprint [CSP] on page 276.

Drawing 6004D, 5-Lead Chip Scale Package (CS) 2x1x2 Ball Pattern [CSP] on pages 279-280.

Drawing 6001C, 8-Lead Chip Scale Package (CS) 3x2x3 Ball Pattern [CSP] on pages 282-283.

Drawing 148A, 121-Lead Plastic Thin Profile Ball Grid Array (BG) 10x10x1.10 mm Body [XBGA] on pages 286-287.

Drawing 2148A, 121-Lead Plastic Thin Profile Ball Grid Array (BG) 10x10x1.10 mm Body Footprint [XBGA] on page 288.

# PACKAGING SPECIFICATION

---

## Revision BD (February 2010)

### The following drawings are new:

Drawings 6008A (2) and 8008A, 4-Lead Chip Scale Package (CS) Package Code AL [CSP] on pages 279-282.

## Revision BE (June 2010)

### The following drawings are new:

Drawing 162A, 8-Lead Thermally Enhanced Plastic Small Outline (SE) Narrow, 3.90 mm Body w/Exp. heat slug [SOIC] on pages 130-131.

Drawing 2162A, 8-Lead Thermally Enhanced Plastic Small Outline (SE) Narrow, 3.90 mm Body Footprint [SOIC] on page 132.

Drawing 120B (Sheet 2), 6-Lead Plastic Dual Flat, No Lead Package (MA) 2x2x0.9 mm Body [DFN] on page 161.

Drawing 2120A, 6-Lead Plastic Dual Flat, No Lead Package (MA) 2x2x0.9 mm Body Footprint [DFN] on page 162.

Drawing 2143B, 24-Lead Plastic Quad Flat, No Lead Package (MJ) 4x4 mm Body Footprint [QFN] on page 193.

Drawing 156A, 40-Lead Plastic Ultra Thin Quad Flat No Lead Package (MV) 5x5 mm Body [UQFN] on pages 214-215.

Drawing 2156A, 40-Lead Plastic Ultra Thin Quad Flat No Lead Package (MV) 5x5 mm Body Footprint [UQFN] on page 216.

Drawing 087C (Sheet 2), 14-Lead Plastic Thin Shrink Small Outline (ST) 4.4 mm Body [TSSOP] on page 241.

Drawing 2044A, 144-Lead Plastic Low Profile Quad Flatpack (PL) 20x20x1.40 mm Body, 2.0 mm Footprint [LQFP] on page 257.

### The following drawings have been revised:

Drawing 2030C 5-Lead Plastic Small Outline Transistor Header (MT) Footprint [SOT-89] on page 60.

Drawing 057C 8-Lead Plastic Small Outline (SN) Narrow, 3.90 mm Body [SOIC] on pages 124-125.

Drawing 057C 8-Lead Plastic Small Outline (OA) Narrow, 3.90 mm Body [SOIC] on pages 124-125.

Drawing 120B 6-Lead Plastic Dual Flat, No Lead Package (MA) 2x2x0.9 mm Body [DFN] on page 160.

Drawing 0129C 8-Lead Plastic Dual Flat, No Lead Package (MN) - 2x3x0.75 mm Body [TDFN] on page 176-177.

Drawing 087C 14-Lead Plastic Thin Shrink Small Outline (ST) 4.4 mm Body [TSSOP] on page 240.

Drawing 044B 144-Lead Plastic Low Profile Quad Flatpack (PL) 20x20x1.40 mm Body, 2.0 mm [LQFP] on page 255-256.

Drawing 008A 4-Lead Chip Scale (CS) [CSP] on page 291.

Drawing 6008A 4-Lead Chip Scale Package PkgCode.AL (continued) (CS) 2x2 Ball Pattern [CSP] on page 292.

Drawing 148B 121-Lead Plastic Thin Profile Ball Grid Array (BG) 10x10x1.10 mm Body [XBGA] on pages 302-303.

Drawing 2148B 121-Lead Plastic Thin Profile Ball Grid Array (BG) 10x10x1.10 mm Body Footprint [XBGA] on page 304.

## Revision BF (July 2010)

Drawings C04-028A and C04-2028A with CHY package designators have been added for the 6-Lead Plastic Small Outline Transistor (CHY) [SOT-23] package and associated land pattern. The drawings appear on pages 53 and 54.

## Revision BG (March 2011)

### The following drawings are new:

Drawing 065C, 14-Lead Plastic Small Outline (SL) Narrow, 3.90 mm Body [SOIC] on page 136.

Drawing 065C, 14-Lead Plastic Small Outline (Sheet 2) (OD) Narrow, 3.90 mm Body [SOIC] on page 139.

Drawing 108C, 16-Lead Plastic Small Outline (Sheet 2) (SL) Narrow, 3.90 mm Body [SOIC] on page 142.

Drawing 102C, 16-Lead Plastic Small Outline (Sheet 2) (SO) Wide, 7.50 mm Body [SOIC] on page 148.

Drawing 102C, 16-Lead Plastic Small Outline (Sheet 2) (OE) Wide, 7.50 mm Body [SOIC] on page 151.

Drawing 051C, 18-Lead Plastic Small Outline (Sheet 2) (SO) Wide, 7.50 mm Body [SOIC] on page 154.

Drawing 094C, 20-Lead Plastic Small Outline (Sheet 2) (SO) Wide, 7.50 mm Body [SOIC] on page 157.

Drawing 025C, 24-Lead Plastic Small Outline (Sheet 2) (SO) Wide, 7.50 mm Body [SOIC] on page 160.

Drawing 025C, 24-Lead Plastic Small Outline (Sheet 2) (OG) Wide, 7.50 mm Body [SOIC] on page 163.

Drawing 052C, 28-Lead Plastic Small Outline (Sheet 2) (SO) Wide, 7.50 mm Body [SOIC] on page 166.

Drawing 052C, 28-Lead Plastic Small Outline (Sheet 2) (OI) Wide, 7.50 mm Body [SOIC] on page 169.

Drawing 078A, 6-Lead Plastic Dual Flat, No Lead Package (MY) 2x2x0.8 mm Body [TDFN] on pages 188-189.

Drawing 185A, 10-Lead Plastic Dual Flat, No Lead Package (MN) 3x3x0.8 mm Body [TDFN] on pages 193-194.

Drawing 063C, 10-Lead Plastic Dual Flat, No Lead Package (Sheet 2) (MF) 3x3x0.9 mm Body [DFN] on page 198.

Drawing 2063B, 10-Lead Plastic Dual Flat, No Lead Package (MF) 3x3x0.9 mm Body Footprint [DFN] on page 199.

# PACKAGING SPECIFICATION

---

Drawing 140B, 28-Lead Plastic Quad Flat, No Lead Package (Sheet 2) (MQ) 5x5x0.9 mm Body [QFN] on page 214.

Drawing 153A, 48-Lead Plastic Ultra Thin Quad Flat No Lead Package (MV) 6x6x0.5 mm Body [UQFN] on pages 235-236.

Drawing 184A, 20-Lead Thermal Leadless Array Package (TL) 3x3x0.7 Exp. Pad [UQFN] on pages 326-237.

Drawing 187B, 36-Lead Thermal Leadless Array Package (TL) 5x5x0.9 Exp. Pad [TLA] on pages 328-329.

Drawing 157B, 44-Lead Thermal Leadless Array Package (TL) 6x6x0.9 Exp. Pad [TLA] on pages 330-331.

## The following drawings have been revised:

Drawing 001C, 8-Lead Ceramic Dual In-Line w/Window (JA) .300" Body [CERDIP] on page 16.

Drawing 027C, 8-Lead Ceramic Dual In-Line (JW) .300" Body [CERDIP] on page 17.

Drawing 002C, 14-Lead Ceramic Dual In-Line (JD) .300" Body [CERDIP] on page 18.

Drawing 099C, 14-Lead Ceramic Dual In-Line w/Window (JW) .300" Body [CERDIP] on page 19.

Drawing 003C, 16-Lead Ceramic Dual In-Line w/Window (JE) .300" Body [CERDIP] on page 20.

Drawing 010C, 18-Lead Ceramic Dual In-Line (JW) .300" Body [CERDIP] on page 21.

Drawing 115C, 20-Lead Ceramic Dual In-Line w/Window (JW) .300" Body [CERDIP] on page 22.

Drawing 004C, 24-Lead Ceramic Dual In-Line (JG) .600" Body [CERDIP] on page 23.

Drawing 006C, 28-Lead Ceramic Dual In-Line (JN) .600" Body [CERDIP] on page 24.

Drawing 080C, 28-Lead Ceramic Dual In-Line w/Window (JW) .300" Body [CERDIP] on page 25.

Drawing 013C, 28-Lead Ceramic Dual In-Line w/Window (JW) .600" Body [CERDIP] on page 26.

Drawing 008C, 40-Lead Ceramic Dual In-Line (JK) .600" Body [CERDIP] on page 27.

Drawing 014C, 40-Lead Ceramic Dual In-Line w/Window (JW) .600" Body [CERDIP] on page 28.

Drawing 162B, 8-Lead Thermally Enhanced Plastic Small Outline (SE) Narrow, 3.90 mm Body [SOIC] on page 132.

Drawing 162B, 8-Lead Thermally Enhanced Plastic Small Outline w/Exp. heat slug (Sheet 2) (SE) Narrow, 3.90 mm Body [SOIC] on page 133.

Drawing 065C, 14-Lead Plastic Small Outline (SL) Narrow, 3.90 mm Body [SOIC] on page 135.

Drawing 065C, 14-Lead Plastic Small Outline (OD) Narrow, 3.90 mm Body [SOIC] on page 138.

Drawing 108C, 16-Lead Plastic Small Outline (SL) Narrow, 3.90 mm Body [SOIC] on page 141.

Drawing 102C, 16-Lead Plastic Small Outline (SO) Wide, 7.50 mm Body [SOIC] on page 147.

Drawing 102C, 16-Lead Plastic Small Outline (OE) Wide, 7.50 mm Body [SOIC] on page 150.

Drawing 051C, 18-Lead Plastic Small Outline (SO) Wide, 7.50 mm Body [SOIC] on page 153.

Drawing 094C, 20-Lead Plastic Small Outline (SO) Wide, 7.50 mm Body [SOIC] on page 156.

Drawing 025C, 24-Lead Plastic Small Outline (SO) Wide, 7.50 mm Body [SOIC] on page 159.

Drawing 025C, 24-Lead Plastic Small Outline (OG) Wide, 7.50 mm Body [SOIC] on page 162.

Drawing 052C, 28-Lead Plastic Small Outline (SO) Wide, 7.50 mm Body [SOIC] on page 165.

Drawing 052C, 28-Lead Plastic Small Outline (OI) Wide, 7.50 mm Body [SOIC] on page 168.

Drawing 2123B, 8-Lead Plastic Dual Flat, No Lead Package (MC) 2x3x0.9 mm Body Footprint [DFN] on page 178.

Drawing 2062B, 8-Lead Plastic Dual Flat, No Lead Package (MF) 3x3x0.9 mm Body Footprint [DFN] on page 181.

Drawing 063C, 10-Lead Plastic Dual Flat, No Lead Package (MF) 3x3x0.9 mm Body [DFN] on page 197.

Drawing 140B, 28-Lead Plastic Quad Flat, No Lead Package (MQ) 5x5x0.9 mm Body [QFN] on page 213.

Drawing 149C, 64-Lead Plastic Quad Flat No Lead Package (MR) 9x9x0.9 mm Body w/7.15x7.15 Exp. pad [QFN] on page 225-226.

Drawing 2156B, 40-Lead Plastic Ultra Thin Quad Flat No Lead Package (MV) 5x5 mm Body Footprint [UQFN] on page 234.

Drawing 2044B, 144-Lead Plastic Low Profile Quad Flatpack (PL) 20x20x1.40 mm Body, 2.0 mm Footprint [LQFP] on page 277.

Drawing 2071B, 44-Lead Plastic Metric Quad Flatpack (KW) 10x10x2 mm Body, 3.20 mm Footprint [MQFP] on page 281.

Drawing 2071B, 44-Lead Plastic Metric Quad Flatpack (PQ) 10x10x2 mm Body, 3.20 mm Footprint [MQFP] on page 283.

Drawing 2022B, 64-Lead Plastic Metric Quad Flatpack (BU) 14x14x2.7 mm Body, 3.20 mm Footprint [MQFP] on page 285.

Drawing 2074B, 32-Lead Plastic Thin Quad Flatpack (PT) 7x7x1.0 mm Body, 2.00 mm Footprint [TQFP] on page 289.

Drawing 2076B, 44-Lead Plastic Thin Quad Flatpack (PT) 10x10x1 mm Body, 2.00 mm Footprint [TQFP] on page 291.

Drawing 2085B, 64-Lead Plastic Thin Quad Flatpack (PT) 10x10x1 mm Body, 2.00 mm Footprint [TQFP] on page 293.

# PACKAGING SPECIFICATION

---

Drawing 2116C, 80-Lead Plastic Thin Quad Flatpack (PF) 14x14x1 mm Body, 2.00 mm Footprint [TQFP] on page 297.

Drawing 2092B, 80-Lead Plastic Thin Quad Flatpack (PT) 12x12x1 mm Body, 2.00 mm Footprint [TQFP] on page 299.

Drawing 2110B, 100-Lead Plastic Thin Quad Flatpack (PF) 14x14x1 mm Body, 2.00 mm Footprint [TQFP] on page 301.

Drawing 2100B, 100-Lead Plastic Thin Quad Flatpack (PT) 12x12x1 mm Body, 2.00 mm Footprint [TQFP] on page 303.

Drawing 155B, 144-Lead Plastic Thin Quad Flatpack (PH) 16x16x1 mm Body, 2.00 mm [TQFP] on page 304.

Drawing 155B, 144-Lead Plastic Thin Quad Flatpack (Sheet 2) (PH) 16x16x1 mm Body, 2.00 mm [TQFP] on page 305.

Drawing 2155B, 144-Lead Plastic Thin Quad Flatpack (PH) 16x16x1 mm Body, 2.00 mm Footprint [TQFP] on page 306.

## Revision BH (November 2011)

### The following drawings are new:

Drawing 121A, 8-Lead Thermally Enhanced Plastic Outline Body (SE) Narrow 3.90 Body on pages 130-131.

Drawing 2121A, 8-Lead Thermally Enhanced Plastic Outline Body (SE) Narrow 3.90 Body Footprint on page 132.

Drawing 194A, 10-Lead Plastic Ultra Thin Dual Flat No Lead (NA[Y]) 3x3x0.5 mm Body [UDFN] on pages 342-343.

Drawing 2148D, 121-Lead Plastic Thin Profile Ball Grid Array (BG) 10x10x1.10 mm Body Footprint [TFBGA] on page 344.

### The following drawings have been revised:

Drawing 111C, 8-Lead Plastic Micro Small Outline Package (MS) [MSOP] on pages 254-255.

Drawing 111C, 8-Lead Plastic Micro Small Outline Package (UA) [MSOP] on pages 257-258.

Drawing 021C, 10-Lead Plastic Micro Small Outline Package (MS) [MSOP] on pages 260-261.

Drawing 021C, 10-Lead Plastic Micro Small Outline Package (UN) [MSOP] on pages 263-264.

Drawing 148D, 121-Lead Plastic Thin Profile Ball Grid Array (BG) 10x10x1.10 mm Body [TFBGA] on pages 342-343.

Drawing 2148D, 121-Lead Plastic Thin Profile Ball Grid Array (BG) 10x10x1.10 mm Body Footprint [TFBGA] on page 344.

## Revision BJ (December 2011)

### The following drawings are new:

Drawing 188A, 8-Lead High Power Dual Flat, No Lead Package (MF) 5x6x1.0 mm Body [PDFN] on pages 200-201.

Drawing 197A, 16-Lead Plastic Quad Flat, No Lead Package (NG) 3x3x0.9 mm Body [QFN] on pages 216-217.

Drawing 2197A, 16-Lead Plastic Quad Flat, No Lead Package (NG) 3x3x0.9 mm Body Footprint [QFN] on page 220.

### The following drawing has been revised:

Drawing 120C, 6-Lead Plastic Dual Flat, No Lead Package (MA[Y]) 2x2x0.9 mm Body [DFN] on pages 180-181.

## Revision BK (June 2012)

### The following drawings are new:

Drawing 141A, 6-Lead Plastic Thin Small Outline Transistor (OS) [TSOT] on pages 78-79.

Drawing 2188B, 8-Lead Plastic Dual Flat No Lead Package (MF) 5x6x1.0 mm Body Footprint [PDFN] on page 204

Drawing 195A, 8-Lead Plastic Dual Flat No Lead Package (LC) 3.3x3.3x1.0 mm Body [PDFN] on pages 205-206.

Drawing 2195A, 8-Lead Plastic Dual Flat No Lead Package (LC) 3.3x3.3x1.0 mm Body Footprint [PDFN] on page 207.

Drawing 078A, 6-Lead Plastic Dual Flat, No Lead Package (MYY) 2x2x0.8 mm Body [TDFN] on pages 212-213.

Drawing 198A, 8-Lead Plastic Dual Flat No Lead Package (LZ) 2x2x0.9 mm Body [VDFN] on pages 226-227.

Drawing 2198A, 8-Lead Plastic Dual Flat No Lead Package (LZ) 2x2x0.9 mm Body Footprint [VDFN] on page 228.

Drawing 2153A, 48-Lead Plastic Ultra Thin Quad Flat No Lead Package (MV) 6x6x0.5 mm Body Footprint [UQFN] on page 273.

Drawing 058A, 128-Lead Plastic Low Profile Quad Flatpack (PT) 14x14x1.4 mm Body [LQFP] on pages 317-318.

Drawing 133A, 256-Lead Plastic Metric Quad Flatpack (PQ) 28x28x3.40 mm Body [MQFP] on pages 330-331.

Drawing 193A, 124-Terminal Very Thin Leadless Array (TL) 9x9x0.9 mm Body [VTLA] on pages 378-379.

### The following drawings have been revised:

Drawing 188B, 8-Lead Plastic Dual Flat No Lead Package (MF) 5x6x1.0 mm Body [PDFN] on pages 202-203.

Drawing 105C, 28-Lead Plastic Quad Flat, No Lead Package (ML) 6x6 mm Body [QFN] on pages 249-250.

Drawing 124C, 28-Lead Plastic Quad Flat, No Lead Package (MM) 6x6x0.9 mm Body [QFN-S] on pages 252-253.

Drawing 184B, 20-Terminal Very, Very Thin Thermal Leadless Array (TL) 3x3x0.7 mm Body [WTLA] on pages 372-373.

Drawing 187C, 36-Terminal Very Thin Thermal Leadless Array (TL) 5x5x0.9 mm Body [VTLA] on pages 374-375.

Drawing 157C, 44-Terminal Very Thin Thermal Leadless Array (TL) 6x6x0.9 mm Body [VTLA] on pages 376-377.

# PACKAGING SPECIFICATION

---

## Revision BL (September 2012)

### The following drawings are new:

Drawing 061B, 5-Lead Plastic Small Outline Transistor (LTY) [SC70] on page 46.

Drawing 2061B, 5-Lead Plastic Small Outline Transistor (LTY) Footprint [SC70] on page 47.

Drawing 103C, 44-Lead Plastic Quad Flat, No Lead Package (ML) 8x8 mm Body [QFN], Sheet 2 was added on page 265.

Drawing 2152A, 28-Lead Plastic Ultra Thin Quad Flat No Lead Package (MV) 4x4x0.5 mm Body Footprint [UQFN] on page 276.

Drawing 209A, 28-Lead Plastic Quad Flat No Lead Package (MV) 6x6x05 Ultra-Thin [UQFN] on pages 277 and 278.

Drawing 2209A, 28-Lead Plastic Quad Flat No Lead Package (MV) 6x6x05 Ultra-Thin Footprint [UQFN] on pages 279.

Drawing 6014B, 32-Lead Chip Scale Package (CS) [CSP] on pages 378 and 379.

### The following drawings have been revised:

Drawing 103C, 44-Lead Plastic Quad Flat, No Lead Package (ML) 8x8 mm Body [QFN], Sheet 1 on page 264.

Drawing 2103C, 44-Lead Plastic Quad Flat, No Lead Package (ML) 8x8 mm Body Footprint [QFN] on page 266.

## Revision BM (December 2012)

### The following drawings are new:

Drawing 203A, 8-Lead Plastic Ultra Thin Small Outline No Lead (NP) 2x3 mm Body [USON] on pages 288-289.

Drawing 210A, 8-Lead Plastic Very, Very Thin Small Outline No Lead (MF) 5x6 mm Body [WSON] on pages 292-293.

Drawing 177A, 48-Lead Thin Small Outline Package (TV) 12x20 mm Body [TSOP] on pages 333-334.

Drawing 199A, 24-Lead Thin Fine Pitch Ball Grid Array (TD) 6x8 mm [TFBGA] on pages 392-393.

Drawing 168B, 48-Lead Thin Fine Pitch Ball Grid Array (CD) 6x8 mm [TFBGA] on pages 394-395.

## Revision BN (April 2013)

### The following drawings are new:

Drawing 2194A, 10-Lead Plastic Ultra Thin Dual Flat No Lead Package (NA[Y]) 3x3x0.5 mm Body Footprint [UDFN] on page 230.

Drawing 213A, 64-Lead Plastic Quad Flat No Lead Package (MR) 9x9x0.9 mm Body w/7.7x7.7 exposed pad [QFN] on pages 272-273.

Drawing 216A, 16-Lead Plastic Ultra Thin Quad Flat No Lead Package (MV) 2.5x2.5x0.6 mm Body [UQFN] on pages 276-277.

Drawing 217A, 16-Lead Extremely Thin Quad Flat No Lead Package (NL) 3x3x0.5 mm Body [XQFN] on pages 290-290.

Drawing 210A, 6-Lead Plastic Super Thin Small Outline No Lead Package (NR) 1.5x1.5x0.4 mm Body [X2SON] on pages 302-303.

### The following drawings have been revised:

Drawing 148E, 121-Lead Plastic Thin Profile Ball Grid Array Package (BG) 10x10x1.10 mm Body [TFBGA], on pages 406-407.

Drawing 187C, 36-Terminal Very Thin Leadless Array Package (TL) 5x5x0.9 mm Body Footprint [WTLA] on page 414.

## Revision BP (September 2013)

### The following drawings are new:

Drawing 047-001A, 40-Lead Plastic Quad Flat (MP) 5x5 mm Body with 3.5 exp pad [QFN] on pages 272-274.

Drawing 047-002A, 40-Lead Plastic Quad Flat (MP) 5x5 mm Body with 3.7 exp pad [QFN] on pages 275-277.

Drawing 211A, 16-Lead Ultra Thin Quad Flat Pack (MV) 3x3x0.50 mm Body [UQFN] on pages 292-294.

Drawing 183A, 48-Lead Thin Quad Flatpack (PT) 7x7x1 mm Body [TQFP] on pages 382-384.

### The following drawings have been revised:

Drawing 029C, 3-Lead Plastic Small Outline Transistor (MB) [SOT-89], on pages 71-73.

Drawing 157D, 8-Lead Plastic Very Very Thin Small Outline (MF) 5x6 mm [WDFN], replacing the drawing of the same name [WSON], on pages 240-242.

Drawing 209B, 28-Lead Ultra Thin Quad Flat No Lead (MX) 6x6x0.5 mm Body and Corner Anchors [UQFN] on pages 295-297.

Drawing 085C, 64-Lead Plastic Thin Quad Flatpack (PT) 10x10x1 mm Body [TQFP], on pages 387-389.

Drawing 157D, 44-Terminal Very Thin Leadless Array (TL) 6x6x0.9 mm [VTLA], on pages 431-433.

## Revision BQ (March 2014)

### The following drawings are new:

[PDIP] Drawing C04-018D 8-Lead Plastic Dual In-Line (P) 300 mil Body on pages 108-109.

[PDIP] Drawing C04-018D 8-Lead Plastic Dual In-Line (PA) 300 mil Body on pages 110-111.

[UDFN] Drawing C04-203A 8-Lead Plastic Ultra Thin Small Outline No Lead Package (NP) 2x3 mm Body on pages 242-243.

# PACKAGING SPECIFICATION

---

[UDFN] Drawing C04-2203A 8-Lead Plastic Ultra Thin Small Outline No Lead Package (NP) 2x3 mm Body Land Pattern on page 244.

[UDFN] Drawing C04-254A 8-Lead Ultra Thin Plastic Dual Flat No Lead Package (RF) 3x3x0.50 mm Body on pages 245-246.

[UDFN] Drawing C04-2254A 8-Lead Ultra Thin Plastic Dual Flat No Lead Package (RF) 3x3x0.50 mm Body Land Pattern on page 247.

[QFN] Drawing C04-259A 16-Lead Plastic Quad Flat No Lead Package (8E) 4x4x0.9 mm Body on pages 268-269.

[QFN] Drawing C04-2259A 16-Lead Plastic Quad Flat No Lead Package (8E) 4x4x0.9 mm Body Land Pattern on page 270.

[QFN] Drawing C04-262A 16-Lead Plastic Quad Flat No Lead Package (FX) 4x4x0.9 mm Body on pages 271-272

[QFN] Drawing C04-2262A 16-Lead Plastic Quad Flat No Lead Package (FX) 4x4x0.9 mm Body Land Pattern on page 273.

[QFN] Drawing C04-260A 64-Terminal Plastic Quad Flat Pack No Lead (RG) 9x9x0.9 mm Body Saw Singulated on pages 313-314.

[QFN] Drawing C04-2260A 64-Lead Very Thin Plastic Quad Flat No Lead (RG) 9x9x1.0 mm Body 4.7 Exp Pad Land Pattern on page 315

[UQFN] Drawing C04-253A 16-Lead Ultra Thin Quad Flat No Lead Package (UC) 3x3x0.5 mm Body on pages 323-324.

[UQFN] Drawing C04-2253A 16-Lead Ultra Thin Quad Flat No Lead Package (UC) 3x3x0.55 mm Body Land Pattern on page 325.

[UQFN] Drawing C04-217A 16-Lead Ultra Thin Quad Flat No Lead Package (UD) 3x3x0.55 mm Body on pages 326-327.

[UQFN] Drawing C04-2217A 16-Lead Ultra Thin Quad Flat No Lead Package (UD) 3x3x0.55 mm Body Land Pattern on page 328.

[UQFN] Drawing C04-257A 16-Lead Ultra Thin Plastic Quad Flat No Lead Package (JQ) 4x4x0.5 mm Body on pages 329-330.

[UQFN] Drawing C04-2257A 16-Lead Ultra Thin Plastic Quad Flat No Lead Package (JQ) 4x4x0.5 mm Body Land Pattern on page 331.

[UQFN] Drawing C04-256A 20-Lead Ultra Thin Plastic Quad Flat No Lead Package (JP) 3x3x0.5 mm Body on pages 332-333.

[UQFN] Drawing C04-2256A 20-Lead Ultra Thin Plastic Quad Flat No Lead Package (JP) 3x3x0.5 mm Body Land Pattern on page 334.

[UQFN] Drawing C04-255A 20-Lead Ultra Thin Plastic Quad Flat No Lead Package (GZ) 4x4x0.5 mm Body on pages 335-336.

[UQFN] Drawing C04-2255A 20-Lead Ultra Thin Plastic Quad Flat No Lead Package (GZ) 4x4x0.5 mm Body Land Pattern on page 337.

[USON] Drawing C04-271A 8-Terminal Plastic Ultra Thin Dual Flat No Lead Package (UB) 4x3x0.55 mm Body Body on pages 356-357.

[USON] Drawing C04-2271A 8-Terminal Plastic Ultra Thin Dual Flat No Lead Package (UB) 4x3x0.55 mm Body Land Pattern on page 358.

[VQFN] Drawing C04-2160A 32-Lead Ultra Thin Plastic Quad Flat No Lead Package (MQ) 5x5x0.9 mm Body Land Pattern on page 366.

[X2SON] Drawing C04-201A 8-Terminal Super Thin Plastic Small Outline No Lead Package (NR) 2x2x0.4 mm (Max) Body on pages 370-371.

[X2SON] Drawing C04-201A 8-Terminal Super Thin Plastic Small Outline No Lead Package (NR) 2x2x0.4 mm (Max) Body Land Pattern on page 372.

[XSON] Drawing C04-205A 8-Lead Extremely Thin Small Outline No-Leads (NF) 2x2x0.45 mm Body on pages 373-374.

[XSON] Drawing C04-205A 8-Lead Extremely Thin Small Outline No-Leads (QX8E) 2x2x0.45 mm Body on pages 375-376.

[TQFP] Drawing C04-220A 44-Lead Plastic Quad Flatpack (MW) 10x10x1.0 mm Body 4.5x4.5 mm Exp Pad Body on pages 444-445.

[CSP] Drawing C04-8014A 32-Ball Wafer Level Chip Scale Package (CS) Land Pattern on page 483.

[TFBGA] Drawing C04-245A 323-Ball Thin Fine Pitch Ball Grid Array (HX) 14x14x1.14 mm Body on pages 497-498.

[VTLA] Drawing C04-2193A 124-Very Thin Leadless Array Package (TL) 9x9x0.9 mm Body Land Pattern on page 510.

## The following drawings have been revised:

[QFN] Drawing C04-140C 28-Lead Plastic Quad Flat No Lead Package (MQ) 5x5x0.9 mm Body on pages 282-283.

[QFN] Drawing C04-2140C 28-Lead Plastic Quad Flat No Lead Package (MQ) 5x5x0.9 mm Body Land Pattern on page 284.

[QFN] Drawing C04-140C 28-Lead Plastic Quad Flat No Lead Package (MQY) 5x5x0.9 mm Body on pages 285-286.

[QFN] Drawing C04-2140C 28-Lead Plastic Quad Flat No Lead Package (MQY) 5x5x0.9 mm Body Land Pattern on page 287.

[USON] Drawing C04-203B 8-Lead Plastic Ultra Thin Small Outline No Lead Package (NP) 2x3 mm Body on pages 354-355.

[VQFN] Drawing C04-140C 28-Lead Plastic Quad Flat No Lead Package (MQ) 5x5x0.9 mm Body on pages 354-355.



# PACKAGING SPECIFICATION

---

## Revision BR (March 2014)

### The following drawings have been revised:

[VDFN] Drawing C04-198B, 8-Lead Very Thin Dual Flatpack No-Lead (LZ) – 2x2x0.9 mm Body on pages 252-253.

[TQFP] Drawing C04-220B, 44-Lead Plastic Quad Flatpack (MW) 10x10x1.0 mm Body 4.5x4.5 mm Exposed Pad on pages 444-445.

## Revision BS (September 2014)

### The following drawings are new:

[QFN] Drawing C04-223A, 48-Lead Plastic Quad Flat, No Lead Package (AIS Package HZH) - 7x7 mm Body on pages 322-323.

[QFN] Drawing 2154A, 64-Lead Plastic Quad Flat, No Lead Package (MR) – 9x9x0.9 mm Body With 0.40 mm Contact Length and 5.40x5.40 mm Exposed Pad (Footprint) on page 327.

[VDFN] Drawing C04-2198A, 8-Lead Plastic Very Thin Flat, No Lead Package (LZ) - 2x2 mm Body With 0.55mm Contact Length (Footprint) on page 268.

[VQFN] Drawing C04-334A, 28-Lead Very Thin Plastic Quad Flat Pack, No Lead Package (PV) 5x5 mm Body With Rectangular Exposed Pad (with Footprint) on pages 378-379.

[VQFN] Drawing C04-160A, 32-Lead Very Thin Plastic Quad Flat, No Lead Package (MQ) 5x5x0.9 mm Body on pages 381-383.

[X2SON] Drawing C04-201-NR-A, 8-Terminal Super-Thin Plastic Small Outline, No Lead Package (NR) - 2x2x0.4 mm (Max) Body on pages 400-402.

[X2SON] Drawing C04-201-XX8E-A, 8-Terminal Super-Thin Plastic Small Outline, No Lead Package (NR) - 2x2x0.4 mm (Max) Body on pages 403-405.

[WLCSP] Drawing C04-6009A, 14-Ball Wafer Level Chipscale Package (CS) - 1.57X2.36 Body - PIC16LF822 (with Footprint) on pages 518-520.

[LGA] SMSC Legacy Drawing for 12x9 mm Body, SIP Module KLR83012 on page 647.

Supertex Legacy – 76 drawings from Supertex were added.

### The following drawings have been revised:

[TDFN-S] Drawing C04-210B, 8-Lead Plastic Very, Very Thin Small Outline No-Lead (MF) - 5x6 mm Body (with Footprint) on pages 251-252.

[QFN] Drawing C04-259B, 16-Lead Plastic Quad Flat, No Lead Package (8E) - 4x4x0.9 mm Body on pages 284-285.

[TQFP] Drawing C04-076C, 44-Lead Plastic Thin Quad Flatpack (PT) - 10x10x1.0 mm Body on pages 472-473.

## Revision BT (December 2014)

### The following drawings are new:

[QFN] Drawing C04-0225A, 24-Lead Plastic Quad Flat, No Lead Package (RU) - 4x4 mm Body, with 2.5x2.5 mm Exposed Pad, Punch Singulated on pages 310-312.

[QFN] Drawing C04-0364A, 24-Lead Plastic Quad Flat, No Lead Package (LY) - 5x5x1.0 mm Body on pages 313-315.

[QFN] Drawing C04-0229A, 40-Lead Plastic Flat, No Lead Package (RR) - 6x6 mm Body, with 4.1x4.1 mm Exposed Pad, Punch Singulated on pages 330-332.

[QFN] Drawing C04-0243A, 72-Lead Plastic Quad Flat, No Lead Package (5E), with 10x10 mm Body, with 6.0x6.0 mm Exposed Pad, Punch Singulated, Dimpled Terminals on pages 359-361.

[MQFP] Drawing C04-0221A, 100-Lead Plastic Metric Quad Flatpack (PQ) - 14x20 mm, with 3.90 mm Footprint on pages 500-501.

[TQFP] Drawing C04-0220A, 44-Lead Plastic Quad Flat, No Lead Package (PT) - 10x10x1.0 mm Body, with 4.5x4.5 mm Exposed Pad on pages 511-512.

[TQFP] Drawing C04-0222A, 64-Lead Plastic Quad Flat, No Lead Package (PT) - 10x10x1.0 mm Body, with 6.0x6.0 mm Exposed Pad on pages 521-522.

[TQFP] Drawing C04-0226A, 128-Lead Plastic Quad Flat, No Lead Package (Z7) - 14x14x1.0 mm, with 5.0x5.0 mm Exposed Pad on pages 531-532.

[WDFN] Drawing C04-0172, 8-Lead Very, Very Thin Small Outline No Lead (MN) - 6x8 mm Body on pages 277-279.

[WSON] Drawing C04-0172, 8-Lead Very, Very Thin Small Outline No Lead (MN) - 6x8 mm Body on pages 282-284.

[VQFN] Drawing C04-0364A, 24-Lead Plastic Quad Flat, No Lead Package (LY) 5x5x1.0 mm Body on pages 400-402.

[LFBGA] Drawing C04-0237A, 196-Ball Low Profile Fine Pitch Ball Grid Array (RG) - 12x12x1.4 mm Body on pages 562-564.

### The following drawings have been revised:

[QFN] Drawing C04-2213B, 64-Lead Plastic Quad Flat, No Lead Package (MR) - 9x9x0.9 mm Body with 0.40 mm Contact Length and 7.70x7.70 mm Exposed Pad Land Pattern on page 355.

[VQFN] Drawing C04-0223B, 48-Lead Plastic Quad Flat, No Lead Package (RS) - 7x7 mm Body, with 5.5x5.5 mm Exposed Pad, Punch Singulated on pages 415-417.

# PACKAGING SPECIFICATION

---

## Revision BU (February 2015)

### The following drawings are new:

[VDFN] Drawing C04-0382A, 8-Lead Very Thin Plastic Dual Flat No Lead Package (8Q) 2x3 Body on pages 301-303.

[VDFN] Drawing C04-0206A, 10-Lead Very Thin Plastic Dual Flat No Lead Package (9Q) 3x3 Body on pages 304-306.

[WDFN] Drawing C04-0261A, 8-Lead Very Very Thin Plastic Dual Flat No Lead (RW) 2x2 mm Body on pages 308-310.

[X2SON] Drawing C04-0338A, 8-Lead Plastic Super-Thin Dual Small Outline No-Lead (8X) 1.5x1.5 mm Body on pages 334-336.

[UQFN] Drawing C04-0386A, 10-Lead Ultra Thin Plastic Quad Flat Package (2V) 1.3x1.8x0.6 mm Body on pages 420-422.

[UQFN] Drawing C04-0379A, 10-Lead Ultra Thin Plastic Quad Flat Package (3V) 1.6x2.1 Body on pages 423-425.

[UQFN] Drawing C04-0385A, 28-Lead Ultra Thin Plastic Quad Flat Package (2N) 6x6x0.55 Body on pages 449-451.

[VQFN] Drawing C04-0272A, 36-Terminal Very Thin Plastic Quad Flatpack (AEN) 6x6x0.9 mm Body on pages 486-488.

[X2QFN] Drawing C04-0376A, 10-Lead Super-Thin Plastic Quad Flat No Lead Package (9X) 1.5x1.5 mm Body on pages 498-500.

[QSOP] Drawing C04-0385A, 24-Lead Plastic Shrink Small Outline Narrow Body (QR) .150 Body on pages 533-535.

[CSP] Drawing C04-6035A, 6035A9-Bump Wafer Level Chip Scale Package (CS) on pages 631-633.

[WLCSP] Drawing C04-6035A, 9-Bump Wafer Level Chip Scale Package (CS) on pages 641-643.

[VFBGA] Drawing C04-0370A, 64-Ball Very Thin Fine Pitch Ball Grid Array (4G) 7x7x1.0 Body on pages 658-660.

[WFBGA] Drawing C04-0380A, 144-Ball Very Very Thin Fine Pitch Ball Grid Array (SZ) 9x9x0.8 Body on pages 662-664.

[VFLGA] Drawing C04-0384A, 56L Very Thin Fine Pitch Land Grid Array (4W) 7x7x0.9 mm Body with Exposed Pad on pages 666-668.

### The following drawings have been revised:

[VQFN] Drawing C04-039C, 20-Lead Plastic Quad Flat No Lead (MQ) 5x5x1.0 mm Body with 0.40 mm Contact Length on pages 467-469.

[VQFN] Drawing C04-0223C, 48-Lead Plastic Quad Flat No Lead (RS) 7x7 mm Body with 5.5x5.5 Exposed Pad, Punch Singulated on pages 489-491.

[QSOP] Drawing C04-0024D, 16-Lead Plastic Shrink Small Outline Narrow Body (QR) .150 Body on pages 530-532.

[WLCSP] Drawing C04-6022D, 8-Bump Extremely Thin Fine Pitch Wafer Level (CS) on pages 638-640.

## Revision BV (March 2015)

### The following drawings are new:

[QFN] Drawing C04-0241A, 36-Lead Plastic Quad Flat (4E) 6x6 mm Body with 3.7x3.7 mm Exposed Pad, Punch Singulated, 0.40 mm Dimpled Terminals on pages 353-355.

[QFN] Drawing C04-0363A, 48-Lead Plastic Quad Flat (5E) 6x6 mm Body with 5.1x5.1 mm Exposed Pad, Punch Singulated, 0.40 mm Dimpled Terminals on pages 371-373.

[VQFN] Drawing C04-0232A, 32-Lead Very Thin Plastic Quad Flat (RN) 5x5 mm Body with 3.3x3.3 mm Exposed Pad, Punch Singulated on pages 462-464.

[VQFN] Drawing C04-0347A, 48-Lead Very Thin Plastic Quad Flat (VQ) 7x7 mm Body with 5.3 Exposed Pad, Punch Singulated on pages 474-476.

[VQFN] Drawing C04-0374A, 56-Lead Very Thin Quad Flat (P6) 8x8 mm with 5.2x5.2 mm Exposed Pad, Punch Singulated on pages 477-479.

[VQFN] Drawing C04-0375A, 56-Lead Very Thin Quad Flat (RT) 8x8 mm with 5.9x5.9 mm Exposed Pad, Punch Singulated on pages 480-482.

[QSOP] Drawing C04-0383A, 24-Lead Plastic Shrink Small Outline Narrow Body (QR) .150" Body on pages 523-525.

[LQFP] Drawing C04-0233A, 100-Lead Low Profile Quad Flatpack (PL) 14x14x1 mm Body on pages 555-557.

## Revision BW (April 2015)

### The following drawings are new:

[SOT-25] Drawings C04-0389A and C04-2389A for the 5-Lead Plastic Small Outline Transistor Package (5A).

[USPQ-4B04] Drawings C04-0383A and C04-2383A for the 4-Lead Plastic Ultra Small Square Package (5X) 1x1x0.6 mm.

[LFBGA] Drawings C04-365A and C04-2365A for the 169-Ball Low Profile Fine Pitch Ball Grid Array (HF) 11x11x1.4 mm Body.

[LFBGA] Drawings C04-366A and C04-2366A for the 288-Ball Low Profile Fine Pitch Ball Grid Array (4J) 15x15x1.4 mm Body.

[LQFP] Drawings C04-367A and C04-2367A for the 176-Lead Low Profile Quad Flat Pack (2J) 20x20x1.4 mm Body with 7x7 mm Exposed Pad.

## Revision BX (May 2015)

### The following drawings are new:

[UQFN] Drawings C04-393B and C04-2393B for the 4-Lead Plastic Ultra Thin Quad Flatpack, No Leads (5X) - 1x1x0.6 mm Body (Formerly USPQ-4B04) on pages 416-418.

# PACKAGING SPECIFICATION

[UQFN] Drawings C04-333A and C04-2333A for the 28-Lead Ultra Thin Plastic Quad Flat, No Lead Package (M6) - 4x4x0.6 mm Body on pages 450-452.

[VQFN] Drawings C04-360A and C04-2360A for the 132-Lead Very Thin Plastic Quad Flat, No Lead (NX) - 10x10x0.9 mm Body Dual Row Terminals, Punch Singulated on pages 514-516.

[MQFN] Drawings C04-186A and C04-286B for the 20-Lead More Thin Plastic Quad Flat, No Lead Package (NU) - 5x5x1.0 mm Body (Also called VQFN) on pages 412-414.

[VFBGA] Drawings C04-371A and C04-2371A for the 78-Ball Very Thin Fine Pitch Ball Grid Array (5G) - 9X9X1.0 mm Body on pages 705-707.

## Revision BY (June 2015)

### The following drawings are new:

[SOT-25] Drawings C04-0389A and C04-2389A for the 5L Plastic Small Outline Transistor Package (5A) on pages 96-98.

[VQFN] Drawings C04-0403B and C04-2403A for the 16-Lead Quad Flat No Lead (7N) 4x4x1.0, Stepped, with 0.40 Terminal Length on pages 476-478.

[VQFN] Drawings C04-0404B and C04-2404A for the 16-Lead Quad Flat No Lead (8N) 3x3x1.0, Stepped, with 0.35 Terminal Length on pages 473-475.

[VQFN] Drawings C04-0402B and C04-2402A for the 20-Lead Quad Flat No Lead (6N) 4x4x1.0, Stepped, with 0.40 Terminal Length on pages 480-482.

[VQFN] Drawings C04-0143B MJ and C04-2143A MJ for the 24-Lead Very Thin Quad Flat (MJ) 4x4x0.9 on pages 488-490.

[VQFN] Drawings C04-0143B S4QFN and C04-2143A S4QFN for the 24-Lead Very Thin Quad Flat (MJ) 4x4x0.9 SMSC Legacy S4QFN on pages 491-493.

[VQFN] Drawings C04-0401B and C04-2401A for the 28-Lead Quad Flat No Lead (5N) 6x6, Stepped, with 0.55 Terminal Length on pages 506-508.

[VQFN] Drawings C04-0400B and C04-2400A for the 28-Lead Quad Flat No Lead (4N) 6x6x1.0, Stepped, with 6.45x6.45 Exposed Pad on pages 509-511.

[VQFN] Drawings C04-0160B MQ and C04-2160C MQ for the 32-Lead Very Thin Quad Flat (MQ) 5x5x0.9 on pages 515-517.

[VQFN] Drawings C04-0160B SQFN and C04-2160C SQFN for the 32-Lead Very Thin Quad Flat (MQ) 5x5x0.9 SMSC Legacy SQFN on pages 518-520.

[VQFN] Drawings C04-0399B and C04-2399A for the 44-Lead Very Thin Quad Flat No Lead (3N) 8x8x1.0, Stepped, on pages 524-526.

[LQFP] Drawings C04-0367A and C04-2367A for the 176-Lead Low Profile Quad Flat Pack (2J) 20x20x1.4 mm Body w-7x7 mm Exposed Pad on pages 623-625.

Supertex [BD] BD\_42\_BumpDiex on page 962.

Supertex [LQFP] FG\_048\_LQFPx on page 987.

Supertex [SOIC] NG\_16\_SOICV1x on page 1040.

### The following drawings are revised:

[QFN] Drawing C04-2229B for the 40-Lead Plastic Quad Flat, No Lead Package (RR) 6x6 mm with 4.1x4.1 mm Exposed Pad Punch Singulated Land Pattern on page 374.

[UQFN] Drawings C04-393C and C04-2393C for the 4-Lead Plastic Ultra Thin Quad Flatpack, No Leads (5X) - 1x1x0.6 mm Body (Formerly USPQ-4B04) on pages 414-416.

[VQFN] Drawings C04-0223C and C04-2223B were renamed to 48-Lead Plastic Quad Flat No Lead Package (RS) 7x7 mm Body with Exposed Pad Punch Singulated (AIS HZH) on pages 527-529.

## Revision BZ (September 2015)

### The following drawings are new:

[VDFN] Drawings C04-0413A and C04-2413A for the 8-Lead Very Thin Plastic Dual Flat (9U) 6x5 with Dual Exposed Pads on pages 288-290.

[VQFN] Drawings C04-0182A and C04-2182A for the 48-Lead Very Thin Quad Flat (ML) 7x7x1.0 mm Body with 5.3x5.3 mm Exposed Pad on pages 537-539.

[VQFN] Drawings C04-0202A and C04-2202A for the 72-Lead Plastic Quad Flat (NQ) 10x10x1.0 mm Body on pages 553-554.

[TQFP] Drawings C04-0300A and C04-2300A for the 48-Lead Thin Quad Flatpack (PT) 7x7x1.0 mm Body on pages 666-668.

[TQFP] Drawings C04-0300A and C04-2300A for the 48-Lead Thin Quad Flatpack (Y8) 7x7x1.0 mm Body on pages 669-671.

### The following drawings are revised:

[QFN] Drawings C04-0127D and C04-2127A for the 16-Lead Plastic Quad Flat (ML) 4x4x0.9 mm Body on pages 344-346.

[UQFN] Drawings C04-0333-M6 B and C04-2333-M6 B for the 28-Lead Ultra Thin Plastic Quad Flat (M6) 4x4x0.6 mm Body with Corner Anchors on pages 454-456.

[UQFN] Drawings C04-0209C and C04-2209B for the 28-Lead Plastic Quad Flat No Lead (MX) 6x6x0.5 Body Ultra-Thin with 0.4x0.6 mm Terminal Width/Length and Corner Anchors on pages 460-462.

[UQFN] Drawings C04-0333-PW B and C04-2333-PW B for the 28-Lead Ultra Thin Plastic Quad Flat (PW) 4x4x0.6 mm Body with Corner Anchors on pages 463-465.

# PACKAGING SPECIFICATION

---

[MSOP] Drawings C04-0021D and C04-2021B for the 10-Lead Plastic Micro Small Outline Package (MS) on pages 588-590.

## Revision CA (November 2015)

### The following drawings are new:

[VDFN] Drawing C04-0413A and C04-2413A for the 8-Lead Very Thin Plastic Dual Flat (9U) 6x5 with Dual Exposed Pads on pages 298-300.

[QFN] Drawings C04-0240A and C04-2240A for the 32-L Plastic Quad Flat (3E) 5x5 mm Body 0.40 mm Terminals with 3.3x3.3 Exposed Pad - Punch Singulated, Dimpled on pages 384-386.

[VQFN] Drawings C04-0182A and C04-2182A for the 48-L Very Thin Quad Flat (ML) 7x7x1 mm with 5.3x5.3 Exposed Pad on pages 549-5551.

[LQFP] Drawings C04-0367A and C04-2367A for the 176-Lead Low Profile Quad Flat Pack (2J) 20x20x1.4 mm Body with 7x7 mm Exposed Pad on pages 651-653.

### The following drawings are revised:

[SOT-89] Drawing C04-0127D for the 3-Lead Plastic Small Outline Transistor (MB) Land Pattern on page 112.

[LFBGA] Drawings C04-0365B and C04-2365B for the 169-Ball Low Profile Fine Pitch Ball Grid Array (HF) 11x11x1.4 mm Body on pages 738-740.

[LFBGA] Drawings C04-0366B and C04-2366B for the 288-Ball Low Profile Fine Pitch Ball Grid Array (4J) 15x15x1.4 mm Body on pages 744-746.

[TFBGA] Drawings C04-0377B and C04-2377B for the 169-Ball Thin Fine Pitch Ball Grid Array (7G) 10x10x1.1 mm Body on pages 755-757.

## Revision CB (December 2015)

### The following drawings are revised:

[TFBGA] Drawings C04-0377C and C04-2377C for the 169-Ball Thin Fine Pitch Ball Grid Array (7G) 10x10x1.1 mm Body on pages 755-757.

## Revision CC (February 2016)

### The following drawings are new:

[SOIC] Drawings C04-0419A and C04-2419A for the 8-Lead Small Outline Integrated Circuit (5DX) .150 In. Body with 3.30x2.41 Exposed Pad on pages 188-190.

[TDFN] Drawings C04-0129A and C04-2129A for the 8-Lead Plastic Dual Flat No Lead Package (MN) 2x3x0.75 mm Body on pages 272-274.

[TDFN] Drawings C04-0129A and C04-2129A for the 8-Lead Plastic Dual Flat No Lead Package (MNY) 2x3x0.75 mm Body on pages 275-277.

[VQFN] Drawings C04-0388A and C04-2388A for the 88-Lead Very Thin Plastic Quad Flat, No Lead Package (KB) 12x12x0.9 mm Punch Singulated Wettable Flanks with 6x6 Exposed Pad on pages 587-589.

[TQFP] Drawing C04-2222A for the 64-Lead Plastic Thin Quad Flatpack (PT) 10x10x1 mm Body with 6x6 Exposed Pad Land Pattern on page 713.

[TQFP] Drawings C04-0418A and C04-2418A for the 128-Lead Thin Quad Flatpack (6XX) 10x10x1.0 mm Body with 10x10 mm Exposed Pad on pages 724-726.

[VFBGA] Drawings C04-0370A and C04-2370A for the 64-Ball Very Thin Fine Pitch (GA) 7x7x1.0 mm Body on pages 791-793.

Micrel Legacy [CERSiP] Drawings for the 6-Lead Ceramic System In Package (AC) 5x7x1.62 mm Body on pages 1154-1155.

Micrel Legacy [FTQFN] Drawings for the 16-Lead FTQFN 2.5x2.5 mm Package (Flip Chip) on pages 1270-1271.

### The following drawings are revised:

[UDFN] Drawings C04-0203C and C04-2203C for the 8-Lead Plastic Ultra Thin Small Outline No Lead Package (NP) 2x3 mm Body on pages 288-290.

[UDFN] Drawings C04-0203C and C04-2203C for the 8-Lead Plastic Ultra Thin Small Outline No Lead Package (PRX) 2x3 mm Body on pages 291-293.

[VDFN] Drawings C04-0206B and C04-2206B for the 10-Lead Very Thin Plastic Dual Flat No Lead Package (9Q) 3x3 mm Body on pages 311-313.

[USON] Drawings C04-0203C and C04-2203C for the 8-Lead Plastic Ultra Thin Small Outline No Lead Package (NP) 2x3 mm Body on pages 326-328.

[USON] Drawings C04-0203C and C04-2203C for the 8-Lead Plastic Ultra Thin Small Outline No Lead Package (PRX) 2x3 mm Body on pages 329-331.

[QFN] Drawings C04-0103D and C04-2103C for the 44-Lead Plastic Quad Flat No Lead Package (ML) 8x8 mm Body on pages 416-418.

[QFN] Drawings C04-0243B and C04-2243B for the 72-Lead Plastic Quad Flat No Lead (6E) 10x10 mm with Exposed Pad Punch Singulated Dimpled on pages 434-436.

[VQFN] Drawings C04-0103D and C04-2103C for the 44-Lead Plastic Quad Flat No Lead Package (ML) 8x8 mm Body on pages 563-565.

[VQFN] Drawings C04-0243B and C04-2243B for the 72-Lead Plastic Quad Flat No Lead (6E) 10x10 mm with Exposed Pad Punch Singulated Dimpled on pages 584-586.

[SSOP] Drawing C04-2072B for the 20-Lead Plastic Shrink Small Outline (SS) 5.30 Land Pattern on page 639.

[TQFP] Drawing C04-0222B for the 64-Lead Plastic Thin Quad Flatpack (PT) 10x10x1 mm Body with 6x6 Exposed Pad on pages 711-712.

# PACKAGING SPECIFICATION

---

[LFBGA] Drawings C04-0366C and C04-2366B for the 288-Ball Low Profile Fine Pitch Ball Grid Array (4J) 15x15x1.4 mm Body on pages 768-770.

[TFBGA] Drawings C04-0377-J Rev. C and C04-2377-J Rev. C for the 169-Ball Thin Fine Pitch Ball Grid Array (7G) 10x10x1.1 mm Body on pages 779-781 (complies with JEDEC terminal assignment recommendations).

[TFBGA] Drawings C04-0377-NJ Rev. C and C04-2377-NJ Rev. C for the 169-Ball Thin Fine Pitch Ball Grid Array (7G) 10x10x1.1 mm Body on pages 782-784 (does not comply with JEDEC terminal assignment recommendations).

[VFBGA] Drawings C04-0371B and C04-2371B for the 78-Ball Very Thin Fine Pitch Ball Grid Array (5G) 9x9x1.0 mm Body on pages 794-796.

[VFBGA] Drawings C04-0371B and C04-2371B for the 78-Ball Very Thin Fine Pitch Ball Grid Array (GA) 9x9x1.0 mm Body on pages 797-799.

Supertex Legacy [BD] Drawing for the 42-Ball Bumped Package Outline (BD) 5.29x5.30 mm Body on page 1032.

Micrel Legacy [QFN] Drawings for the QFN77-48LD-PL-1 C 1 and 2 on pages 1417-1418.

## Revision CD (April 2016)

### The following drawings are new:

[VDFN] Drawings C04-0332A and C04-2332A for the 10-Lead Very Thin Plastic Dual Flat (9R) 2.5x2.0 mm Body on pages 289-291.

[TFBGA] Drawings C04-0212A and C04-2212A for the 121-Ball Thin Fine Pitch Ball Grid Array (3XX) SiP 8x8 mm Body on pages 756-758.

[TFBGA] Drawings C04-0212A and C04-2212A for the 121-Ball Thin Fine Pitch Ball Grid Array (TE) SiP 8x8 mm Body on pages 759-761.

### The following drawings are revised:

[UQFN] Drawings C04-0385B and C04-2385B for the 28-Lead Ultra Thin Plastic Quad Flat, No Lead Package (2N) 6x6x0.55 mm Body with 4.65x4.65 mm Exposed Pad and Corner Anchors on pages 469-471.

## Revision CE (May 2016)

### The following drawings are new:

[CABGA] Drawings C0-0414A and C0-2414A for the 22-Ball Chip Array Ball Grid Array (JY) 5x7 mm Body on pages 832-834.

[LLGA] Drawings C0-1068A and C0-3068A for the 6-Lead Low Profile Land Grid Array (APA) 7x5 mm Body on pages 839-841.

[LLGA] Drawings C0-1071A and C0-3071A for the 6-Lead Low Profile Land Grid Array (ANA) 5.0x3.2 mm Body on pages 836-838.

[SOIC] Drawings C0-0423A and C0-2423A for the 8-Lead Small Outline Integrated Circuit (7HX) .150 in. with 1.65x1.65 Exposed Pad on pages 192-194.

[TFBGA] Drawings C0-0328A and C0-2328A for the 100-Ball Thin Fine Pitch Ball Grid Array (GJX) 7x7 mm Body on pages 858-860.

[TFBGA] Drawings C0-1193A and C0-3193A for the 132-Ball Thin Fine Pitch Ball Grid Array (AHA) 12x12x1.2 mm Internal Flip Chip on pages 870-872.

[TFBGA] Drawings C0-0429A and C0-2429A for the 144-Ball Thin Fine Pitch Ball Grid Array (JWX) 7x7 mm Body on pages 873-875.

[TSSOP] Drawings C0-0424A and C0-2424A for the 38-Lead Thin Shrink Small Outline Package (SBX) 4.4 mm Body with 4.6x3.2 Exposed Pad on pages 723-725.

[VDFN] Drawings C0-1006A and C0-3006A for the 4-Lead Very Thin Plastic Dual Flatpack (H4A) 3.2x2.5 mm Body on pages 310-312.

[VDFN] Drawings C0-1005A and C0-3005A for the 6-Lead Very Thin Dual Flatpack (J7A) 2.5x2 mm Body on pages 313-315.

[VDFN] Drawings C0-1007A and C0-3007A for the 6-Lead Very Thin Plastic Dual Flatpack (H5A) 3.2x2.5 mm Body on pages 316-318.

[VDFN] Drawings C0-1197A and C0-3197A for the 11-Lead Very Thin Plastic Dual Flat Package (K4A) 6x5 mm Body with Dual Fused Exposed Pads on pages 334-336.

[VDFN] Drawings C0-1198A and C0-3198A for the 14-Lead Very Thin Plastic Quad Flat (JHA) 4.5x3 mm Body with Dimpled Wettable Flanks on pages 337-339.

[VFLGA] Drawings C0-1199A and C0-3199A for the 4-Lead Very Thin Fine Pitch Land Grid Array (ARA) 1.6x1.2 mm Body on pages 906-908.

[VFLGA] Drawings C0-1200A and C0-3200A for the 4-Lead Very Thin Fine Pitch Land Grid Array (ASA) 2x1.6 mm Body on pages 909-911.

[VFLGA] Drawings C0-1202A and C0-3202A for the 4-Lead Very Thin Land Grid Array (AUA) 2.5x2 mm Body on pages 912-914.

[VFLGA] Drawings C0-1203A and C0-3203A for the 6-Lead Very Thin Fine Pitch Land Grid Array (AVA) 1.6x1.2 mm Body on pages 915-917.

[VFLGA] Drawings C0-1201A and C0-3201A for the 6-Lead Very Thin Fine Pitch Land Grid Array (ATA) 2x1.6 mm Body on pages 918-920.

[VFLGA] Drawings C0-1204A and C0-3204A for the 6-Lead Very Thin Fine Pitch Land Grid Array (AWA) 2.5x2 mm Body on pages 921-923.

[VQFN] Drawings C0-0421A and C0-2421A for the 20-Lead Very Thin Plastic Quad Flat (LXX) 3x3x0.9 mm Body Internal Flip Chip on pages 545-547.

# PACKAGING SPECIFICATION

---

[VQFN] Drawings C0-1205A and C0-3205A for the 32-Lead Very Thin Plastic Quad Flat (P5A) 5x5x0.9 mm Body with 3.5x3.5 Exposed Pad on pages 590-592.

[VQFN] Drawings C0-1196A and C0-3196A for the 32-Lead Very Thin Plastic Quad Flat (PHA) 6x6 mm Body Wettable Flanks Multiple Exposed Pads on pages 593-595.

[VQFN] Drawings C0-1109A and C0-3109A for the 40-Lead Very Thin Plastic Quad Flat (PQA) 6x6 mm Body with 4.1x4.1 Exposed Pad on pages 605-607.

[VQFN] Drawings C0-1206A and C0-3206A for the 40-Lead Very Thin Quad Flat (NPA) 5x6.5 mm Body with Dimpled Wettable Flanks on pages 602-604.

[VQFN] Drawings C0-0430A and C0-2430A for the 52-Lead Very Thin Plastic Quad Flat (8HX) 8x8 mm Body with 6.6x6.6 Exposed Pad on pages 632-634.

## **The following drawings are revised:**

[QFN] Drawings C0-00149D and C0-2149C for the 64-Lead Very Thin Plastic Quad Flat (R4X) 9x9x0.9 mm Body with 7.15x7.15 Exposed Pad on pages 451-453.

[QFN] Drawings C0-00149D and C0-2149C for the 64-Lead Very Thin Plastic Quad Flat (MR) 9x9x0.9 mm Body with 7.15x7.15 Exposed Pad on pages 448-450.

[SC70] Drawings C0-00060C and C0-2060B for the 3-Lead Plastic Small Outline Transistor (LB) on pages 78-80.

[SC70] Drawings C0-00061D and C0-2061B for the 5-Lead Plastic Small Outline Transistor (LT) on pages 81-83.

[SC70] Drawings C0-0151B and C0-2151B for the 6-Lead Plastic Small Outline Transistor (LT) on pages 86-88.

[TDFN] Drawings C0-0129E and C0-2129B for the 8-Lead Plastic Dual Flat (MN) 2x3x0.8 mm Body with 1.4x1.3 Exposed Pad on pages 280-282.

[TDFN] Drawings C0-0129E and C0-2129B for the 8-Lead Plastic Dual Flat (MNY) 2x3x0.8 mm Body with 1.4x1.3 Exposed Pad on pages 283-285.

[TFBGA] Drawings C0-0212B and C0-2212B for the 121-Ball Thin Fine Pitch Ball Grid Array (TE) 8x8 mm SiP on pages 864-866.

[TFBGA] Drawings C0-1191B and C0-3191B for the 168-Ball Fine Pitch Ball Grid Array (AFA) 13x13x1.2 mm Internal Flip Chip on pages 876-878.

[VDFN] Drawings C0-0198C and C0-2198C for the 8-Lead Very Thin Flat Dual Package (LZ) 2x2 mm Body with 0.55 Contact Length on pages 319-321.

[VDFN] Drawings C0-0332B and C0-2332A for the 10-Lead Very Thin Plastic Dual Flat (9R) 2.5x2.0 mm Body on pages 328-330.

[VQFN] Drawings C0-0272B and C0-2272B for the 36-Terminal Very Thin Plastic Quad Flatpack (AEN) 6x6x0.9 mm Body on pages 599-601.

[VQFN] Drawings C0-0272B and C0-2272B for the 36-Terminal Very Thin Plastic Quad Flatpack (M2) 6x6x0.9 mm Body on pages 596-598.

[VQFN] Drawings C0-0182B and C0-2182C for the 48-Lead Very Thin Quad Flat (ML) 7x7x1 mm Body with 4.1x4.1 Exposed Pad on pages 614-616.

[VQFN] Drawings C0-0182B and C0-2182C for the 48-Lead Very Thin Quad Flat (Y3X) 7x7x1 mm Body with 4.1x4.1 Exposed Pad on pages 617-619.

[VQFN] Drawings C0-0431B and C0-2431A for the 48-Lead Very Thin Quad Flat (ML) 7x7x1 mm Body with 5.3x5.3 Exposed Pad on pages 620-622.

[VQFN] Drawings C0-0431B and C0-2431A for the 48-Lead Very Thin Quad Flat (Y9X) 7x7x1 mm Body with 5.3x5.3 Exposed Pad on pages 623-625.

[VQFN] Drawings C0-0149D and C0-2149C for the 64-Lead Very Thin Plastic Quad Flat (MR) 9x9x0.9 mm Body with 7.15x7.15 Exposed Pad on pages 641-643.

[VQFN] Drawings C0-0149D and C0-2149C for the 64-Lead Very Thin Plastic Quad Flat (R4X) 9x9x0.9 mm Body with 7.15x7.15 Exposed Pad on pages 644-646.

# PACKAGING SPECIFICATION

Revision CF (October 2016)

The following drawings have been added or modified:

LFBGA	C04-0439A C04-2439A	169-Ball Low Profile Ball Grid Array (6JX) 11x11 mm Body
LFBGA	C04-0369A C04-2369A	256-Ball Low Profile Fine Pitch Ball Grid Array (3J) 14x14 mm Body
LQFP	C04-0053A C04-2053A	64-Lead Low Profile Plastic Quad Flatpack (PL) 10x10 mm
LQFP	C04-0432A C04-2432A	160-Lead Low Profile Quad Flatpack (6G) 24x24 mm with 2.00 mm Footprint
QFN	C04-0301A-6FX C04-2301A-6FX	80-Lead Plastic Quad Flat (6FX) 11x11x0.9 mm Body
QFN	C04-0301A-8FX C04-2301A-8FX	80-Lead Plastic Quad Flat (8FX) 11x11x0.9 mm Body
SOT-23	C04-0091D (CT) C04-2091A (CT)	5-Lead Plastic Small Outline Transistor (CT)
SOT-23	C04-0028C (OT) C04-2028B (OT)	5-Lead Plastic Small Outline Transistor (OT)
SOT-23	C04-0028C (CH) C04-2028B (CH)	6-Lead Plastic Small Outline Transistor (CH, CHY)
SOT-23	C04-0028C (OT) C04-2028B (OT)	6-Lead Plastic Small Outline Transistor (OT, OTY)
TFBGA	C04-0429B C04-2429A	84-Ball Thin Fine Pitch Ball Grid Array (GQ) 6x6 mm Body
TFBGA	C04-0320A C04-2320A	100-Ball Thin Fine Pitch Ball Grid Array (GJ) 7x7 mm Body
TFBGA	C04-0212B-3XX C04-2212B-3XX	121-Ball Thin Pitch Ball Grid Array (3XX) 8x8 mm SiP
TFBGA	C04-0212B-TE C04-2212B-TE	121-Ball Thin Pitch Ball Grid Array (TE) 8x8 mm SiP
TFBGA	C04-0327A-2H C04-2327A-2H	129-Ball Thin Fine Pitch Ball Grid Array (2H) 7x7 mm Body
TFBGA	C04-0327A-GW C04-2327A-GW	129-Ball Thin Fine Pitch Ball Grid Array (GW) 7x7 mm Body
TFBGA	C04-0429B C04-2429A	144-Ball Thin Fine Pitch Ball Grid Array (JWX) 7x7 mm Body
TQFP	C04-0066B C04-2066A	64-Lead Thin Quad Flatpack (JVX) 10x10x1 mm Body 2.00 Footprint 5.7x5.7 mm Exposed Pad
UFBGA	C04-0411A C04-2411A	25-Ball Ultra Thin Fine Pitch Ball Grid Array (FE) 3x3 mm Body
UQFN	C04-0247A C04-2247A	12-Lead Ultra Thin Quad Flat (QM) 2x2 mm Body SST Legacy
UQFN	C04-0264A C04-2264A	20-Lead Ultra Thin Quad Flat (NC) 3x3 mm SST Legacy
UQFN	C04-0436A-M5 C04-2436A-M5	36-Lead Ultra Thin Plastic Quad (M5) 5x5 mm with Corner Anchors
UQFN	C04-0436A-SCX C04-2436A-SCX	36-Lead Ultra Thin Plastic Quad (SCX) 5x5 mm with Corner Anchors
UQFN	C04-0442-M4 C04-2442-M4	48-Lead Ultra Thin Plastic Quad Package (M4) 6x6 mm Corner Anchors 4.6x4.6 Exposed Pad
UQFN	C04-0442-PTX C04-2442-PTX	48-Lead Ultra Thin Plastic Quad Package (PTX) 6x6 mm Corner Anchors 4.6x4.6 Exposed Pad
USON	C04-0200A C04-2200A	8-Lead Ultra Thin Small Outline (ND) 2x2 Body SST Legacy
VDFN	C04-1010A C04-3010A	6-Lead Very Thin Quad Flat (H8A) 7x5 mm with 2.8x1.8 Exposed Pad
VDFN	C04-0198D C04-2198D	8-Lead Very Thin Flat Dual No Lead (LZ) 2x2 mm with 1.7x0.9 Exposed Pad
VDFN	C04-1207A C04-3207A	8-Lead Very Thin Plastic Dual Flat (J8A) 2x2 mm with 1.7x0.9 mm Exposed Pad
VDFN	C04-1210A C04-3210A	8-Lead Very Thin Plastic Dual Flat (JEA) 3x2 mm with Dimpled Wettable Flanks
VDFN	C04-0405A C04-2405A	14-Lead Very Thin Plastic Dual Flat No Lead (4S) 4.5x3.0 mm Body

# PACKAGING SPECIFICATION

VFPGA	C04-0422A C04-2422A	61-Ball Very Thin Pitch Ball Grid Array (5HX) 5x5x0.9 Body
VFLGA	C04-0373A-2W C04-2373A-2W	68-Lead Very Thin Fine Pitch Land Grid Array (2W) 8x8x0.9 mm Body with Exposed Pads ISSC Legacy
VFLGA	C04-0373A-7W C04-2373A-7W	68-Lead Very Thin Fine Pitch Land Grid Array (7W) 8x8x0.9 mm Body with Exposed Pads ISSC Legacy
VLGA	C04-1215A C04-3215A	6-Lead Very Thin Land Grid Array (ALA) 3.2x2.5 mm Body
VQFN	C04-1208C C04-3208B	10-Lead Very Thin Quad Flat (MRA) 2x2 mm with Fused Exposed Pad
VQFN	C04-0403C C04-2403B	16-Lead Plastic Quad Flat (7N) 4x4x1.0 mm Wettable Flanks Stepped 0.40 Terminal Length
VQFN	C04-0404C C04-2404B	16-Lead Plastic Quad Flat (8N) 3x3x1.0 mm Wettable Flanks Stepped 0.35 Terminal Length
VQFN	C04-0392A	16-Lead Very Thin Quad Flat (MG) 3x3 mm with 1.1x1.1 mm Exposed Pad
VQFN	C04-0196A C04-2196A	16-Lead Very Thin Quad Flat (MG) 3x3 mm with 1.65x1.65 mm Exposed Pad
VQFN	C04-0381A C04-2381A	16-Lead Very Thin Plastic Quad Flat No Lead Package (AP) 4x4
VQFN	C04-0402C C04-2402B	20-Lead Plastic Quad Flat (6N) 4x4x1.0 mm Wettable Flanks Stepped 0.40 Terminal Length
VQFN	C04-1212B C04-3212A	24-Lead Very Thin Quad Flat (NVA) 3x4 mm with Multiple Exposed Pad Wettable Flanks
VQFN	C04-0401C C04-2401B	28-Lead Plastic Quad Flat (5N) 6x6x1.0 mm with 4.10x4.10 Exposed Pad Wettable Flanks Stepped
VQFN	C04-0400C C04-2400B	28-Lead Very Thin Quad Flat (4N) 6x6x1.0 mm with 3.7x3.7 Exposed Pad Wettable Flanks
VQFN	C04-0426A C04-2426A	28-Lead Very Thin Quad Flat (9PX) 5x5 mm with Stepped Wettable Flanks 3.25x3.25 mm Exposed Pad
VQFN	C04-0160B-S8 C04-2160C-S8	32-Lead Very Thin Quad Flat (S8) 5x5x0.9 mm with 3.7x3.7 mm Exposed Pad
VQFN	C04-0425A C04-2425A	40-Lead Very Thin Quad Flat (NHX) 5x5 mm with 3.7x3.7 mm Exposed Pad and Wettable Flanks
VQFN	C04-0339A C04-2339A	40-Lead Very Thin Quad Flat (UW) 6x6 mm Saw Singulated ISSC Legacy
VQFN	C04-0344A C04-2344A	40-Lead Very Thin Quad Flat (VM) 6x6 mm Body with 4.62x4.62 Exposed Pad ISSC Legacy
VQFN	C04-1213A C04-3213A	44-Lead Very Thin Quad Flat (PGA) 7x7x0.9 mm with 5.1x5.1 Exposed Pad
VQFN	C04-0358A C04-2358A	48-Lead Very Thin Quad Flat (UV) 5x6.5 mm Saw Singulated ISSC Legacy
VQFN	C04-0341A C04-2341A	48-Lead Very Thin Quad Flat (UY) 7x7 mm Saw Singulated ISSC Legacy
VQFN	C04-0345A C04-2345A	48-Lead Very Thin Quad Flat (VN) 6x6 mm Body Saw Singulated ISSC Legacy
VQFN	C04-0427A C04-2427A	48-Lead Very Thin Quad Flat (VSX) 6x6 mm with 4.3x4.3 mm Exposed Pad
VQFN	C04-0349A C04-2349A	48-Lead Very Thin Quad Flat (VT) 7x7 mm Body Saw Singulated ISSC Legacy
VQFN	C04-0430A C04-2430A	52-Lead Very Thin Quad Flat (8HX) 8x8 mm with 6.6x6.6 mm Exposed Pad
VQFN	C04-0350A C04-2350A	56-Lead Very Thin Plastic Quad Flat (VU) 7x7 mm Body ISSC Legacy
VQFN	C04-0234A C04-2234A	56-Lead Very Thin Quad Flat (2G) 7x7 mm Body
VQFN	C04-0342A C04-2342A	56-Lead Very Thin Quad Flat (UZ) 7x7 mm Body Saw Singulated ISSC Legacy
VQFN	C04-0352A C04-2352A	56-Lead Very Thin Quad Flat (VW) 8x8 mm Saw Singulated ISSC Legacy
VQFN	C04-0394A C04-2394A	64-Lead Very Thin Quad Flat (3S) 9x9 mm with 0.95mm Package Height
VQFN	C04-0434A C04-2434A	64-Lead Very Thin Quad Flat (9JX) 9x9 mm with 6x6 mm Exposed Pad



# PACKAGING SPECIFICATION

VQFN	C04-0361A C04-0361A C04-0361A C04- 0361A	64-Lead Very Thin Quad Flat (RG) 9x9 mm Punch Singulated 64-Lead Very Thin Quad Flat (RG) 9x9 mm with 4.7x4.7 Exposed Pad Punch Singulated 64-Lead Very Thin Quad Flat (RG) 9x9 mm with 6x6 Exposed Pad Punch Singulated 64-Lead Very Thin Quad Flat (RG) 9x9 mm with 7.3x7.3 Exposed Pad Punch Singulated
VQFN	C04-0354A C04-2354A	68-Lead Very Thin Quad Flat (VY) 8x8 mm with 6.2x6.2 Exposed Pad Saw Singulated ISSC Legacy
VQFN	C04-1195A C04-3195A	76-Lead Very Thin Quad Flat (QBA) 9x9 mm with 5x5 mm Exposed Pad
VQFN	C04-0274A C04-2274A	88-Lead Very Thin Quad Flat (PJ) 12x12 mm Body
VQFN	C04-0407A C04-2407A	100-Lead Very Thin Quad Flat (KD) 12x12 mm Body
WFBGA	C04-0408A C04-2408A	64-Ball Very Very Thin Fine Pitch Ball Grid Array (7U) 6x6 mm
WFBGA	C04-0390A C04-2390A	84-Ball Very Very Thin Fine Pitch Ball Grid Array (SX) 7x7 mm
WFBGA	C04-0391A C04-2391A	100-Ball Very Very Thin Fine Pitch Ball Grid Array (SY) 8x8 mm
WFBGA	C04-0336A C04-2336A	169-Ball Very Very Thin Fine Pitch Ball Grid Array (TN) 11x11 mm
WLCSP	C04-6036A	16-Ball Wafer Level Chip Scale Package (CS) 2.215x2.16x0.7 mm Body
WQFN	C04-0440A C04-2440A	16-Lead Very Very Thin Quad Flat (NGA) 3x3 mm Body with 1.5x1.5 Exposed Pad
X2QFN	C04-0204A C04-2204A	16-Lead Super Thin Quad Flat No Lead (NT) 2.5x2.5 mm SST Legacy
XFBGA	C04-0337A C04-2337A	144-Ball Extremely Thin Fine Pitch Ball Grid Array (TZ) 7x7 mm Body

## Revision CG (October 2016)

The following drawings have been restored:

[TBGA] Drawings for C0-0199B for the 24-Ball Thin Profile Ball Grid Array (TD) 6x8 mm Body on pages 970-971.

## Revision CH (February 2017)

The following drawings are revised:

[TFBGA] Drawings for C0-01193B for the 132-Ball Thin Fine Pitch Ball Grid Array (AHA) 12x12x1.2 mm Body on pages 1016-1018.



**MICROCHIP**

---

---

**Package Outlines and Dimensions**

---

---

NOTES:

## **APPENDIX B: CONTROL DIMENSIONS**

Microchip inspects the first lot of every new package. Thereafter, one lot of each package, from each assembly site, shall be inspected yearly.

The following dimensions shall be inspected on all types of packages:

- Package Length
- Package Width
- Package Height
- Lead or Contact Width
- Lead or Contact Pitch

The following packages contain dimensions that shall be added to the inspection described above.

### **B.1 On Surface Mount Devices (SMD)**

- § Lead Coplanarity<sup>1</sup>
- § Standoff\*
- Molded Package Length (if different from overall package length)
- Side Flash
- Foot Angle

### **B.2 Through-Hole**

- § Lead Span\*

### **B.3 Surface Mount Devices And Through-Hole**

- Molded Package Width
- Molded Package Thickness

### **B.4 DFN and QFN Only**

- Contact Length
- Contact to Exp. Pad
- Exp. Pad Length
- Exp. Pad Width

---

<sup>1</sup> The § symbol denotes a significant characteristic specified in the control plan.

# PACKAGING SPECIFICATION

---

NOTES:

## APPENDIX C: GEOMETRIC DIMENSIONING AND TOLERANCING

In its Package Outline Drawings, Microchip follows the JEDEC usage of Geometric Dimensioning and Tolerancing (GD&T), as defined in ASME Y14.5M. This standard is published by the American Society of Mechanical Engineers and is considered the authoritative guideline. Here is a brief explanation of how GD&T is applied in this specification.

### DEFINITIONS

A *Datum* is a theoretically exact point, plane or axis. Other dimensions are established from one or more datums. A *datum feature* is an actual part or feature of an object that establishes a datum.

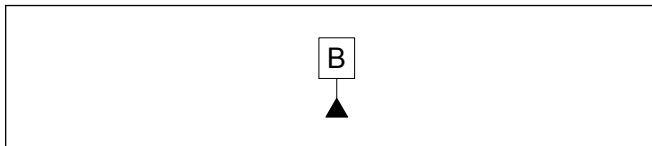

Figure 1. Datum Symbol

Dimensions are expressed as either Standard, Basic (BSC) or Reference (REF).

A *Standard Dimension* typically includes a tolerance, either listed in the dimension table as minimum, maximum and nominal, or as a range or a plus-or-minus value.

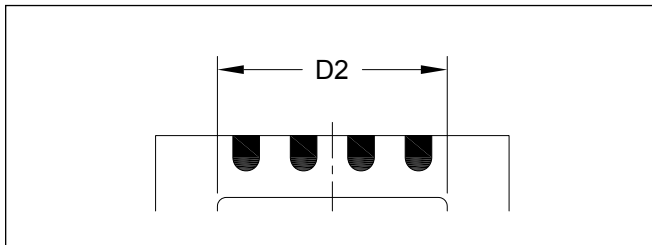

Figure 2. Standard Dimension

A *Basic Dimension* (BSC) describes a theoretically exact size, profile, orientation, etc., and is provided without tolerance. The permissible variations are provided by tolerances on other dimensions or in feature control frames (see Figure 5 below). Basic dimensions are shown inside rectangular frames.

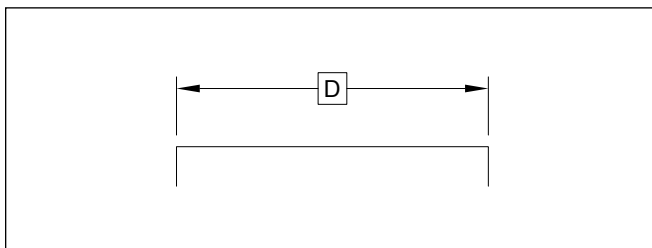

Figure 3. Basic Dimension

Reference Dimensions (REF) are provided for information purposes only and are not used to control or verify characteristics of objects. Reference dimensions are enclosed in parentheses.

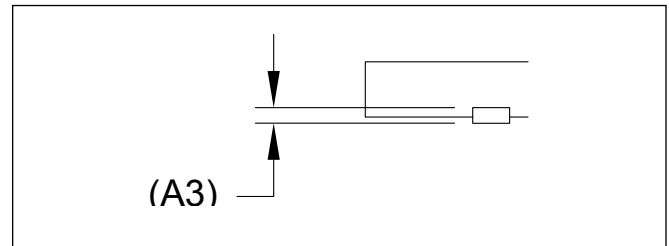

Figure 4. Reference Dimension

A *Feature Control Frame* specifies a geometric tolerance for an individual feature. The frame is divided into compartments which contain symbols and numeric values.

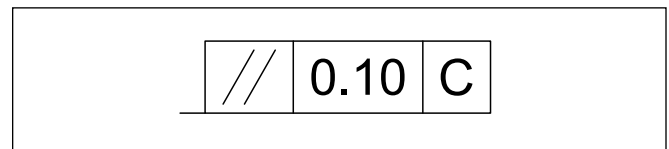

Figure 5. Feature Control Frame

# PACKAGING SPECIFICATION

The elements of feature control frames are illustrated below:

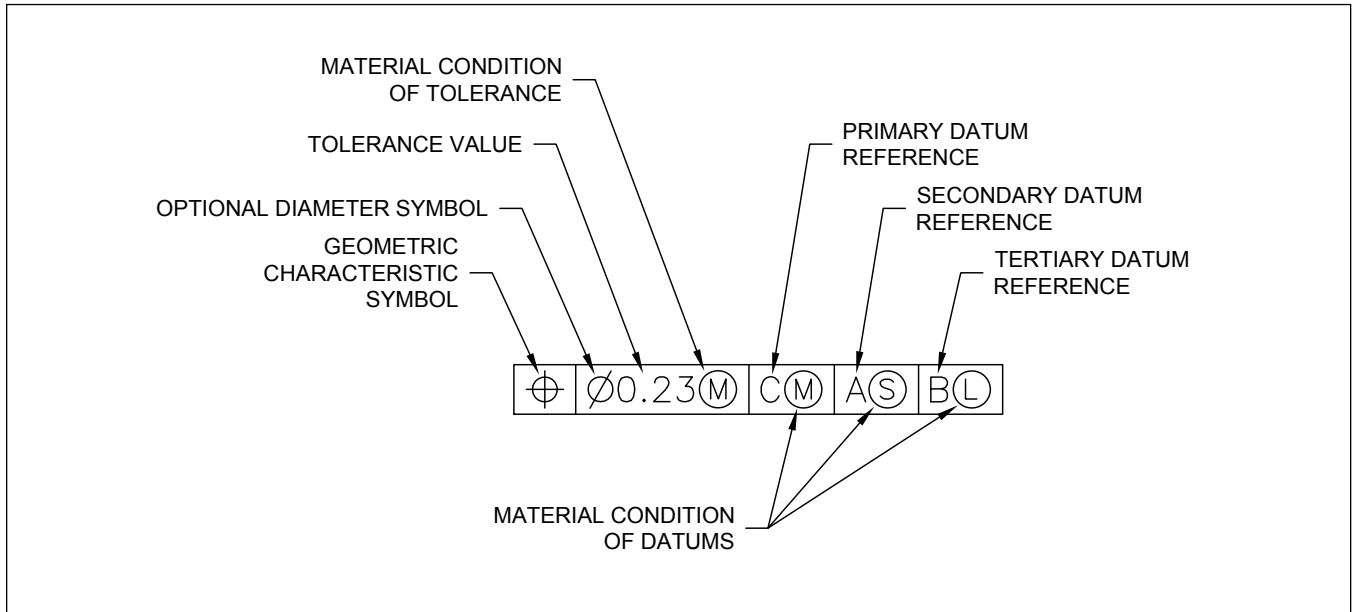

Figure 6. Elements of a Feature Control Frame

The *geometric characteristic symbol* specifies the type of tolerance listed, in the categories of form, profile, location, orientation and runout (a combination of controls).

The *tolerance value*, along with its optional diameter symbol, indicates the numeric value being specified.

The *datum reference* letters indicate the datums from which the tolerance is established, listed in order of importance.

Various *material condition* indicators are used as necessary (see Figure 8 below).

Not all elements appear in every feature control frame.

## GEOMETRIC CHARACTERISTIC SYMBOLS

Microchip generally uses four of the fourteen symbols (as of this writing) as follows:

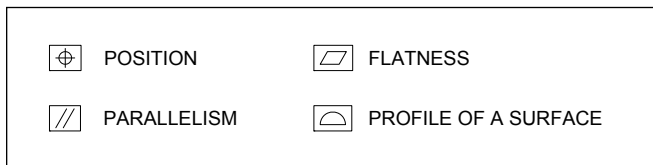

Figure 7. Selected Geometric Characteristics Symbols

A Positional tolerance defines how much a feature may vary from a theoretically exact position.

Parallelism refers to a feature, surface or edge being parallel to another surface, edge, plane, etc.

Flatness and profile of a surface refer to the amount any point on a surface may deviate from a theoretically exact plane or surface. The Profile of a Surface also controls such characteristics as the angle or twist of a surface, and may be applied to a curved or flat surface.

## MATERIAL CONDITION SYMBOLS

Microchip package outline drawings might use one of the following symbols within feature control frames:

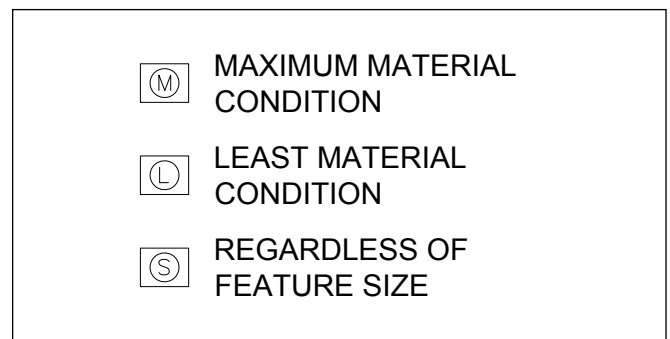

Figure 8. Material Condition Symbols

# PACKAGING SPECIFICATION

**Maximum Material Condition (MMC)** indicates a tolerance is applied to an object or feature at its maximum amount of material. This would include the largest external boundary, or the smallest internal opening in the object.

**Least Material Condition (LMC)** is just the opposite: it indicates an object at its smallest external boundary, or the largest internal opening in the object.

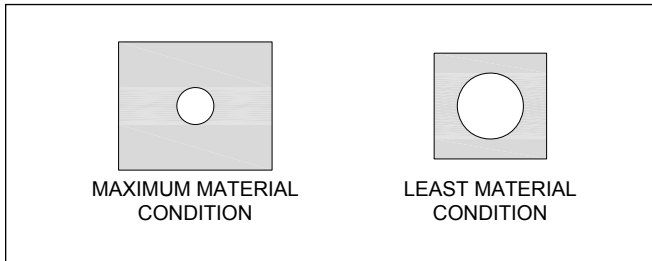

Figure 9. Examples of Maximum Material Condition and Least Material Condition of an object. The shaded areas represent material.

**Regardless of Feature Size (RFS)** indicates the tolerance is independent of the actual size of the object.

## INTERPRETING THE SYMBOLS

Most Microchip Package Outline Drawings contain at least three Datums. Typically, they are defined as shown in Figure 10:

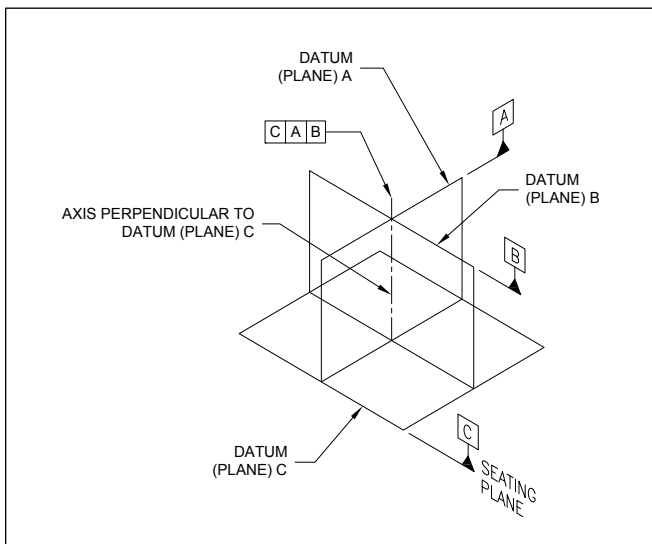

Figure 10. Typical Datums in a Package Outline Drawing

Additional Datums might also be used.

By definition, Datum A in the example below is a plane halfway between the extension lines in dimension **D**. Consider the vertical centerline as the plane viewed edge-on.

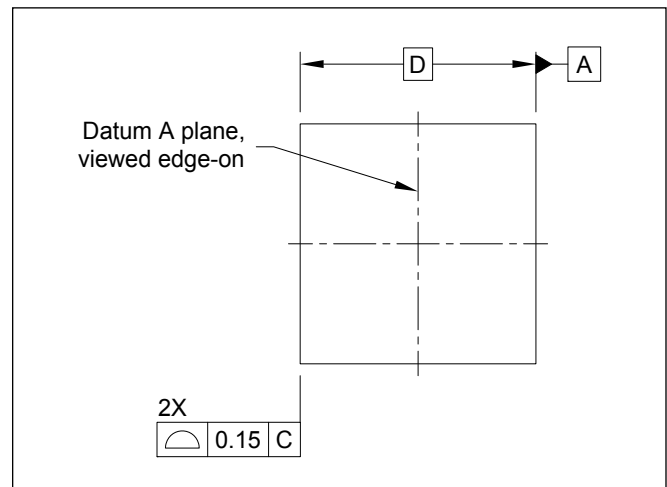

Figure 11. Example of a Datum Plane and Feature Control Frame Related to a Basic Dimension

The associated feature control frame indicates the variations permitted with this Basic dimension. The above illustration should be interpreted to mean that no point on the two edges defined by Dimension **D** may deviate from a theoretically exact surface by more than 0.15 units†.

Though it might not seem logical, the surface profile is derived from Datum C, the Seating Plane, which is perpendicular to the surfaces. This should be interpreted as relating to an axis perpendicular to Datum C. That axis is usually located at the intersection of Datums A and B (see Figure 10).

Some drawings use an alternate method of defining Datums. For example, in Figure 12 the datum at the centerline at the middle of Dimension **E** is called Datum A-B. The datum perpendicular to A-B is called Datum D.

† Units may be Inches or millimeters as defined in the drawing's dimension table.

# PACKAGING SPECIFICATION

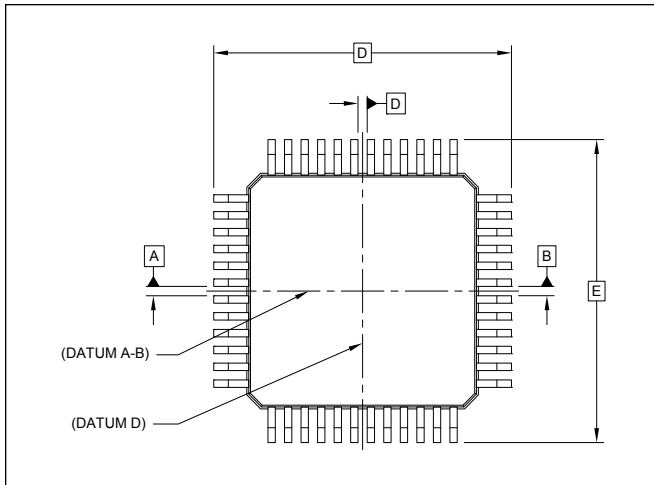

Figure 12. Alternate Datum Definition

Another frequently used feature control frame is associated with Dimension **E**, the terminal pitch.

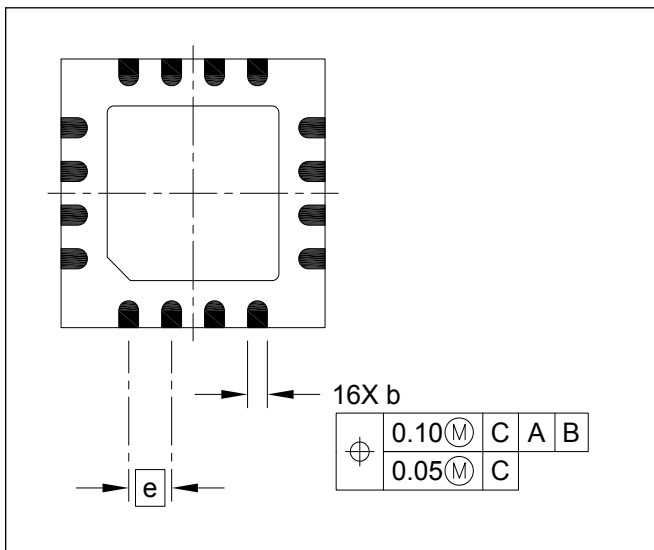

Figure 13. Terminal Pitch, Terminal Width and Tolerance of Position

Dimension **b** in Figure 13 describes the terminal width and indicates that the dimension applies to all sixteen terminals. The feature control frame below dimension **b** associates the positional tolerance to the terminal pitch and indicates:

1. The entire array of terminals may not deviate more than 0.10 units any direction from its theoretically exact position related to Datums C, A and B simultaneously.
2. No single terminal may deviate more than 0.05 units from its theoretically exact location within the array, related to an axis perpendicular to Datum C.

These tolerances apply to the terminals when they are at Maximum Material Condition (MMC). If the terminals are less than MMC, their tolerances may be increased by the difference between MMC and the actual size.

The individual object position tolerance must always be less than the overall array position tolerance.

Figure 14 is a typical first page of a Microchip package outline drawing, with annotations describing various elements of the dimensioning.



# PACKAGING SPECIFICATION

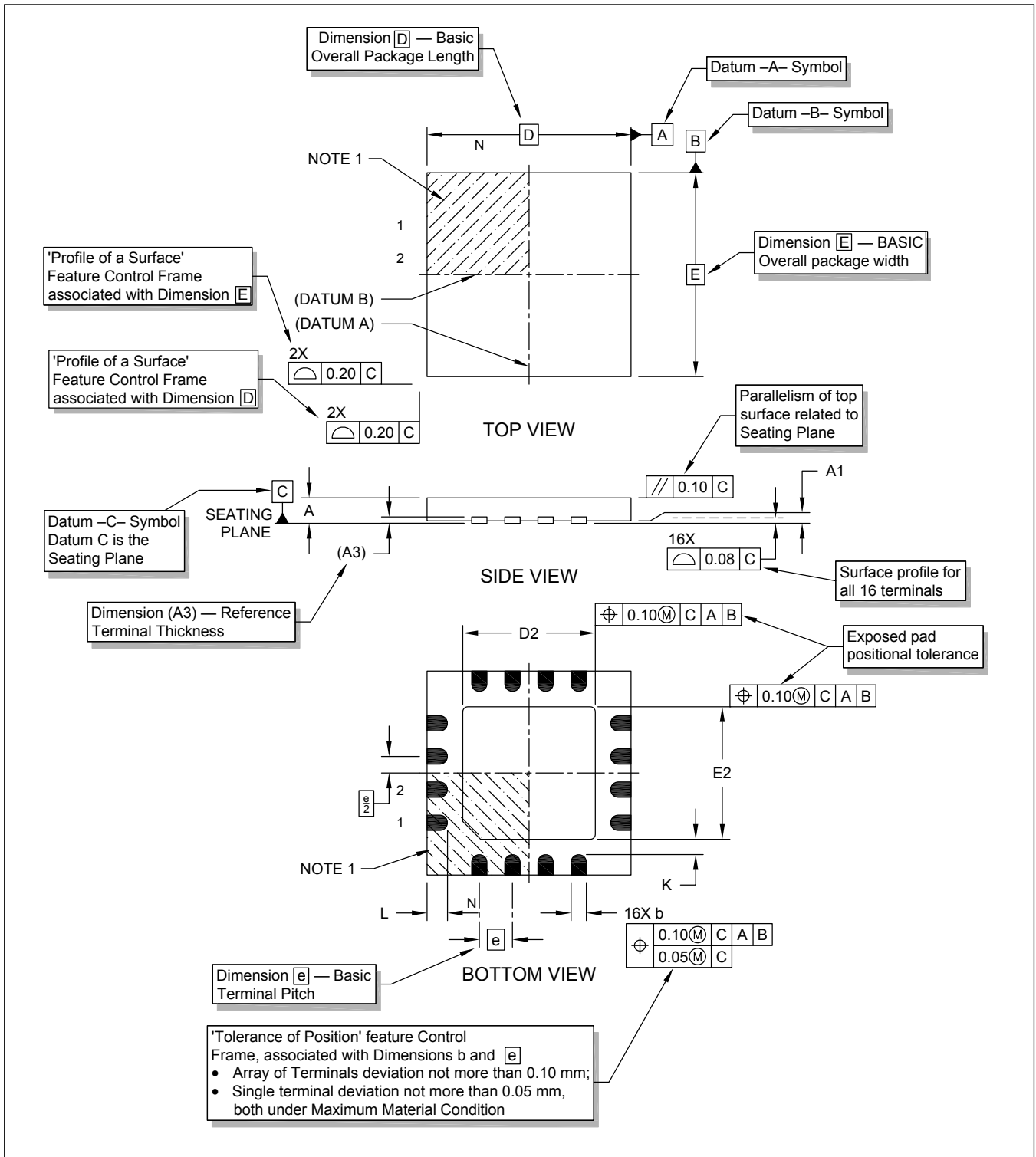

Figure 14. Annotated Package Outline Drawing

# PACKAGING SPECIFICATION

---

NOTES:

## Overview of Microchip Die/Wafer Support

### INTRODUCTION

In addition to packaged devices, Microchip Technology Inc. devices are available in wafer and die form. All products sold in die or wafers have been characterized and qualified according to the requirements of Microchip Technology Inc. Specifications SPI-41014, "Characterization and Qualification of Integrated Circuits" and QCI-39000, "Worldwide Quality Conformance Requirements".

### PRODUCT INTEGRITY

Product supplied in die or wafer form is fully tested and characterized. Die and wafers are inspected to Microchip Technology Inc. Specification, QCI-30014.

#### CAUTION

Some EEPROM devices use EPROM cells for device configuration. Exposure to ultraviolet light must be avoided. Exposure to ultraviolet light may cause the device to operate improperly.

Extreme care is urged in the handling and assembly of these products since they are susceptible to damage from electro-static discharge.

### PACKAGING OPTIONS

Die/wafer products are available as individual Die in Waffle Pack, Whole Wafers or as Sawn Wafer on Frame. As a standard, all die on a wafer are tested and Ink Dots are used to indicate the bad die on a wafer. Inkless wafers with electronic wafer maps are also available upon request. To acquire individual electronic wafer maps, customers can request a password-protected account on a Microchip FTP site where their wafer maps are stored and easily downloaded.

Various wafer thicknesses are available, which include 8, 11, 15 and 29 mils for unground wafers. Standard wafer thickness varies from product to product, so contact your Microchip Sales Office for details.

### ORDERING INFORMATION

Die sales must be initiated by contacting your Microchip Sales Office. To order or to obtain information (on pricing or delivery) for a specific device, use one of the following part numbers.

#### Standard Thickness Die/Wafer

DEVICE.NUMBER/S	Die in Waffle Pack	EEPROM Examples
DEVICE.NUMBER/W	Whole Wafers	24LC01B-I/S
DEVICE.NUMBER/WF	Sawn Wafer on Frame	24LC01B-I/W
		24LC01B-I/WF

#### No Backgrind Wafers

DEVICE.NUMBER/WNBG	Whole Wafers with Ink	24LC01B-I/WNBG
DEVICE.NUMBER/WNBI	Whole Wafers without Ink	24LC01B-I/WNBI

#### Standard Die/Wafers with Manufacturing Process Included in Part Number

DEVICE.NUMBER/SXXX	Die in Waffle Pack	24LC01B-I/S15K
DEVICE.NUMBER/WXXX	Whole Wafers	24LC01B-I/W15K
DEVICE.NUMBER/WFXXX	Sawn Wafer on Frame	24LC01B-I/WF15K

DEVICE.NUMBER is the base part number of the device that you require, the S specifies Die in Waffle Pack, a W specifies a Whole Wafer and WF specifies Sawn Wafer on Frame. Whole wafers specified as NBG are shipped as inked wafers with no backgrind (29 mils) and those specified as NBI are shipped with no backgrind and without Ink.

As further clarification, the manufacturing process is sometimes indicated with a three digit suffix added at the end of the part number. For example, a wafer from the 160K process will use the suffix 16K, one from the 150K process will use 15K and one from the 121K process will use 12K.

---

## Overview of Microchip Die/Wafer Support

---

### ELECTRICAL SPECIFICATIONS

The functional and electrical specifications of Microchip devices in die form are identical to those of a packaged version. Please refer to individual data sheets for complete details.

### DIE MECHANICAL SPECIFICATIONS

Refer to the individual data Sheet for these specifications.

### BOND PAD COORDINATES

The die figures have associated bond pad coordinates. These coordinates assist in the attaching of the bond wire to the die. All the dimensions of these coordinates are in micrometers (mm) unless otherwise specified. The origin for the coordinates is the center of the die, as shown in Figure 1. Refer to the specific die data Sheet for each device for openings and pitch.

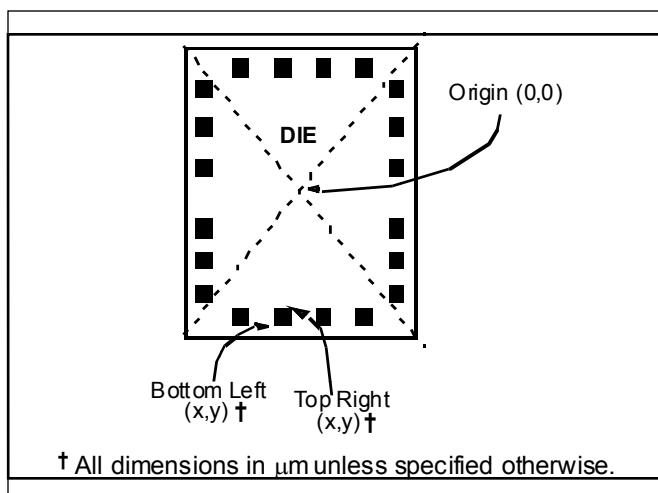

**FIGURE 1:** Die Coordinate Origin

The die is capable of thermosonic gold or ultrasonic wire bonding. Die meet the minimum conditions of MIL-STD 883, Method 2011 on “Bond Strength (Destructive Bond Pull Test)”. The Bond Pad metallization is silicon doped aluminum.

### SUBSTRATE BONDING

Substrate bonding may be required on certain product families. For more information, refer to the specific die data Sheet for that product.

### SHIPPING OPTIONS

#### Die Form (/S)

Microchip product in die form can be shipped in waffle pack. The waffle pack has sufficient cavity area to restrain the die, while maintaining their orientation. Lint free paper inserts are placed over the waffle packs, and each pack is secured with a plastic locking clip. Groups of waffle packs are assembled into sets for shipment. A label with lot number, quantity and part number is attached.

These waffle packs are hermetically sealed in bags.

#### Wafer Form (/W)

Products may also be shipped in wafer form (see ordering information). Wafers are uncut and shipped in a wafer tub. The tub is padded with non-conductive foam. Lint free paper inserts are placed around each wafer. A label with lot number, quantity and part number is attached.

#### Sawn Wafer on Frames (/WF)

Products may also be shipped on wafer frames. Wafers are mounted on plastic frames and 100% sawn through. Sawn wafer on frames may be shipped in bulk (25 wafers per carrier) or as a single wafer in a carrier. A label with lot number, quantity and part number is attached with each shipment.

#### Storage Procedures

Temperature and humidity greatly affect the storage life of die. It is recommended that the die be used as soon as possible after receipt.

Upon receipt, the sealed bags should be stored in a cool and dry environment (25°C and 25% relative humidity). In these conditions, sealed bags have a shelf life of 12 months. Temperatures or humidities greater than these will reduce the storage life.

Once a bag containing waffle packs has been opened, the devices should be assembled and encapsulated within 48 hours (assuming 25°C and 25% humidity).



**MICROCHIP**

---

---

**Package Outlines and Dimensions**

---

---

**NOTES:**

## Worldwide Sales and Service

### AMERICAS

**Corporate Office**  
2355 West Chandler Blvd.  
Chandler, AZ 85224-6199  
Tel: 480-792-7200  
Fax: 480-792-7277  
Technical Support:  
<http://www.microchip.com/support>  
Web Address:  
[www.microchip.com](http://www.microchip.com)

#### Atlanta

Duluth, GA  
Tel: 678-957-9614  
Fax: 678-957-1455

#### Austin

Tel: 512-257-3370

#### Boston

Westborough, MA  
Tel: 774-760-0087  
Fax: 774-760-0088

#### Chicago

Itasca, IL  
Tel: 630-285-0071  
Fax: 630-285-0075

#### Dallas

Addison, TX  
Tel: 972-818-7423  
Fax: 972-818-2924

#### Detroit

Novi, MI  
Tel: 248-848-4000

#### Houston

Tel: 281-894-5983

#### Indianapolis

Noblesville, IN  
Tel: 317-773-8323  
Fax: 317-773-5453

#### Los Angeles

Mission Viejo, CA  
Tel: 949-462-9523  
Fax: 949-462-9608  
Tel: 951-273-7800

#### New York, NY

Tel: 631-435-6000

#### San Jose, CA

Tel: 408-735-9110  
Tel: 408-436-4270

#### Canada, Toronto

Tel: 905-695-1980  
Fax: 905-695-2078

### ASIA/PACIFIC

**Asia Pacific Office**  
Suites 3707-14, 37th Floor  
Tower 6, The Gateway  
Harbour City, Kowloon

#### Hong Kong

Tel: 852-2943-5100  
Fax: 852-2401-3431

#### Australia - Sydney

Tel: 61-2-9868-6733  
Fax: 61-2-9868-6755

#### China - Beijing

Tel: 86-10-8569-7000  
Fax: 86-10-8528-2104

#### China - Chengdu

Tel: 86-28-8665-5511  
Fax: 86-28-8665-7889

#### China - Chongqing

Tel: 86-23-8980-9588  
Fax: 86-23-8980-9500

#### China - Dongguan

Tel: 86-769-8702-9880

#### China - Hangzhou

Tel: 86-571-8792-8115  
Fax: 86-571-8792-8116

#### China - Hong Kong SAR

Tel: 852-2943-5100  
Fax: 852-2401-3431

#### China - Nanjing

Tel: 86-25-8473-2460  
Fax: 86-25-8473-2470

#### China - Qingdao

Tel: 86-532-8502-7355  
Fax: 86-532-8502-7205

#### China - Shanghai

Tel: 86-21-3326-8000  
Fax: 86-21-3326-8021

#### China - Shenyang

Tel: 86-24-2334-2829  
Fax: 86-24-2334-2393

#### China - Shenzhen

Tel: 86-755-8864-2200  
Fax: 86-755-8203-1760

#### China - Wuhan

Tel: 86-27-5980-5300  
Fax: 86-27-5980-5118

#### China - Xian

Tel: 86-29-8833-7252  
Fax: 86-29-8833-7256

### ASIA/PACIFIC

#### China - Xiamen

Tel: 86-592-2388138  
Fax: 86-592-2388130

#### China - Zhuhai

Tel: 86-756-3210040  
Fax: 86-756-3210049

#### India - Bangalore

Tel: 91-80-3090-4444  
Fax: 91-80-3090-4123

#### India - New Delhi

Tel: 91-11-4160-8631  
Fax: 91-11-4160-8632

#### India - Pune

Tel: 91-20-3019-1500

#### Japan - Osaka

Tel: 81-6-6152-7160  
Fax: 81-6-6152-9310

#### Japan - Tokyo

Tel: 81-3-6880-3770  
Fax: 81-3-6880-3771

#### Korea - Daegu

Tel: 82-53-744-4301  
Fax: 82-53-744-4302

#### Korea - Seoul

Tel: 82-2-554-7200  
Fax: 82-2-558-5932 or  
82-2-558-5934

#### Malaysia - Kuala Lumpur

Tel: 60-3-6201-9857  
Fax: 60-3-6201-9859

#### Malaysia - Penang

Tel: 60-4-227-8870  
Fax: 60-4-227-4068

#### Philippines - Manila

Tel: 63-2-634-9065  
Fax: 63-2-634-9069

#### Singapore

Tel: 65-6334-8870  
Fax: 65-6334-8850

#### Taiwan - Hsin Chu

Tel: 886-3-5778-366  
Fax: 886-3-5770-955

#### Taiwan - Kaohsiung

Tel: 886-7-213-7830

#### Taiwan - Taipei

Tel: 886-2-2508-8600  
Fax: 886-2-2508-0102

#### Thailand - Bangkok

Tel: 66-2-694-1351  
Fax: 66-2-694-1350

### EUROPE

#### Austria - Wels

Tel: 43-7242-2244-39  
Fax: 43-7242-2244-393

#### Denmark - Copenhagen

Tel: 45-4450-2828  
Fax: 45-4485-2829

#### Finland - Espoo

Tel: 358-9-4520-820

#### France - Paris

Tel: 33-1-69-53-63-20  
Fax: 33-1-69-30-90-79

#### France - Saint Cloud

Tel: 33-1-30-60-70-00

#### Germany - Garching

Tel: 49-8931-9700

#### Germany - Haan

Tel: 49-2129-3766400

#### Germany - Heilbronn

Tel: 49-7131-67-3636

#### Germany - Karlsruhe

Tel: 49-721-625370

#### Germany - Munich

Tel: 49-89-627-144-0  
Fax: 49-89-627-144-44

#### Germany - Rosenheim

Tel: 49-8031-354-560

#### Israel - Ra'anana

Tel: 972-9-744-7705

#### Italy - Milan

Tel: 39-0331-742611  
Fax: 39-0331-466781

#### Italy - Padova

Tel: 39-049-7625286

#### Netherlands - Drunen

Tel: 31-416-690399  
Fax: 31-416-690340

#### Norway - Trondheim

Tel: 31-416-690399

#### Poland - Warsaw

Tel: 48-22-3325737

#### Romania - Bucharest

Tel: 40-21-407-87-50

#### Spain - Madrid

Tel: 34-91-708-08-90  
Fax: 34-91-708-08-91

#### Sweden - Gothenberg

Tel: 46-31-704-60-40

#### Sweden - Stockholm

Tel: 46-8-5090-4654

#### UK - Wokingham

Tel: 44-118-921-5800  
Fax: 44-118-921-5820