

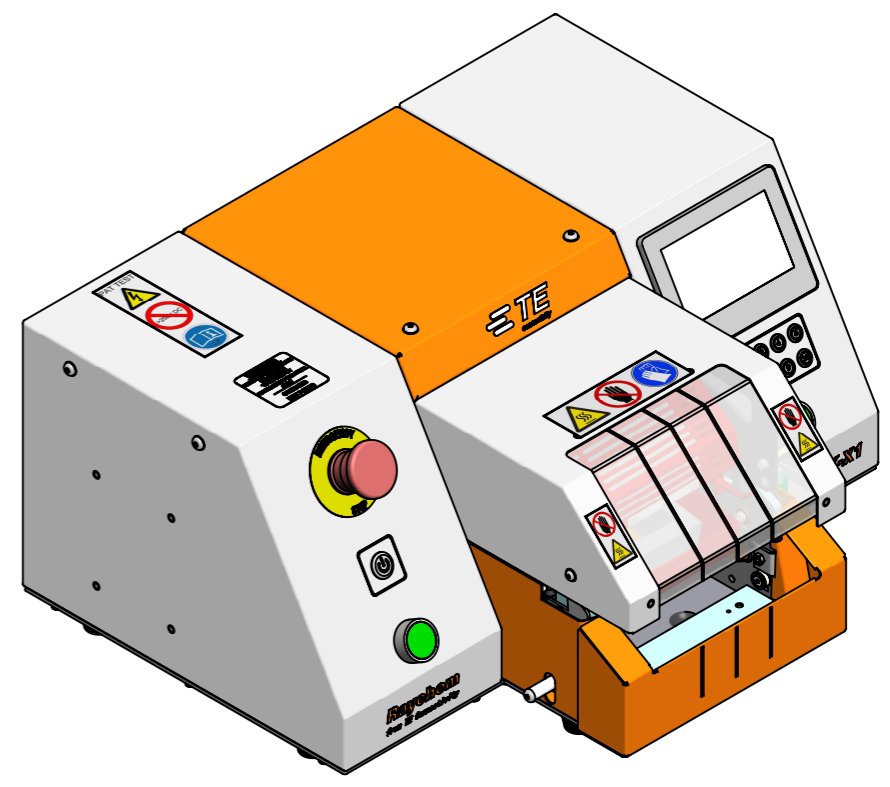

PART NUMBER	REV	FIRST USED	TYPE
2234800-1	A	-	STANDARD
2234800-2	A	-	CE VERSION

REVISIONS					
P	LTR	DESCRIPTION	DATE	DWN	APVD
	A	INITIAL RELEASE	14AUG19	CZ	

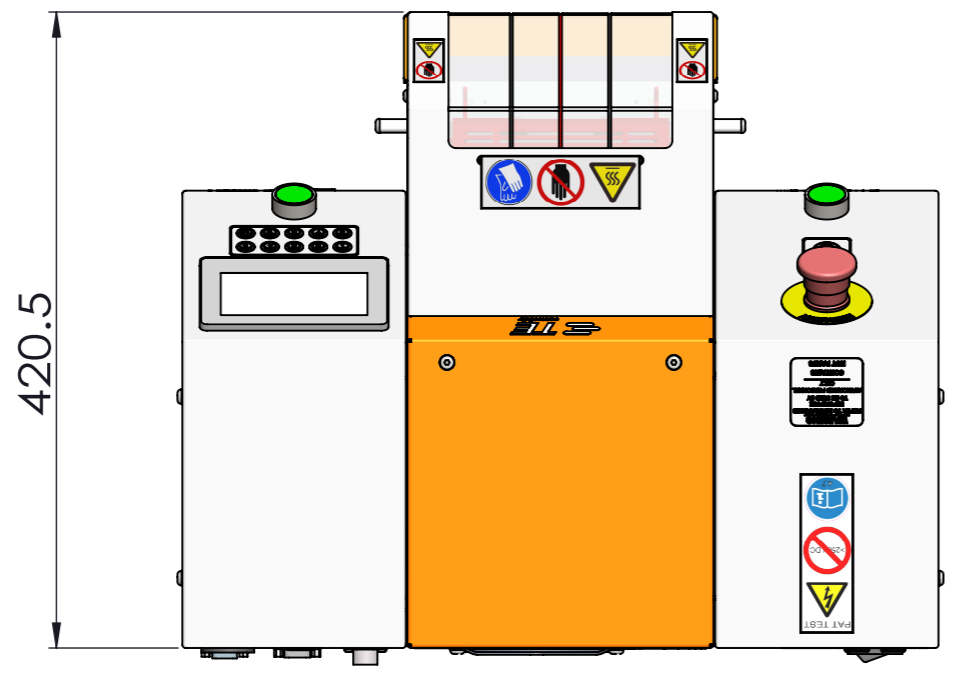
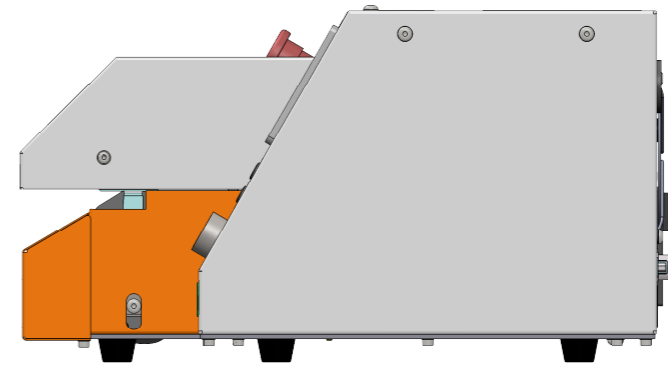
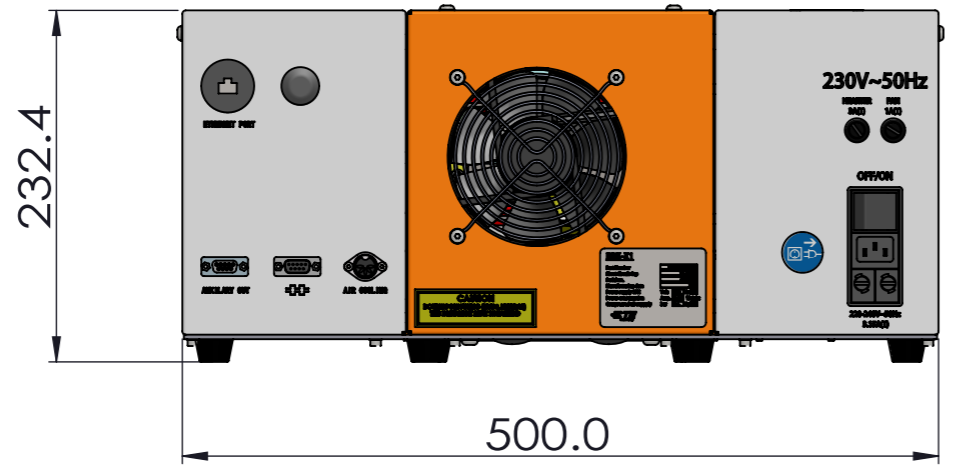

1. 2234800-1 DETAILS SEE SHEET 2, 2234800-2 DETAILS SEE SHEET 3.
 2. SPARE PARTS LIST SEE SHEET 4.

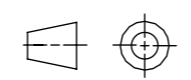
THIS DRAWING IS A CONTROLLED DOCUMENT.		DWN	C.ZHU	14AUG19	 TE Connectivity	
DIMENSIONS: mm		CHK				
		TOLERANCES UNLESS OTHERWISE SPECIFIED:		NAME		
MATERIAL		FINISH		PRODUCT SPEC		RBK-X1 HEAT SHRINK MACHINE
				SEE FIRST USED		
				APPLICATION SPEC		SIZE
				WEIGHT		A3
				CUSTOMER DRAWING		RESTRICTED TO
				SCALE		1:5
				SHEET		1 OF 4
				REV		A
				DRAWING NO		C-2234800

PART NUMBER	REV	FIRST USED	TYPE
2234800-1	A	-	STANDARD
2234800-2	A	-	CE VERSION

REVISIONS					
P	LTR	DESCRIPTION	DATE	DWN	APVD
	A	INITIAL RELEASE	14AUG19	CZ	

2234800-1

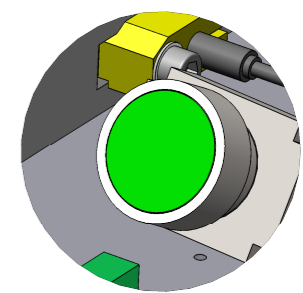
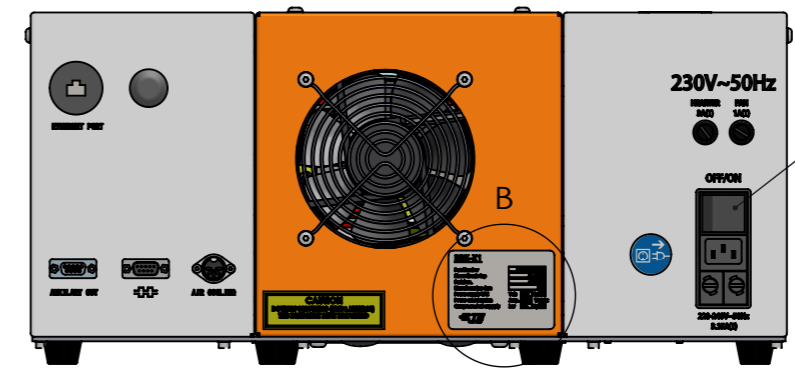
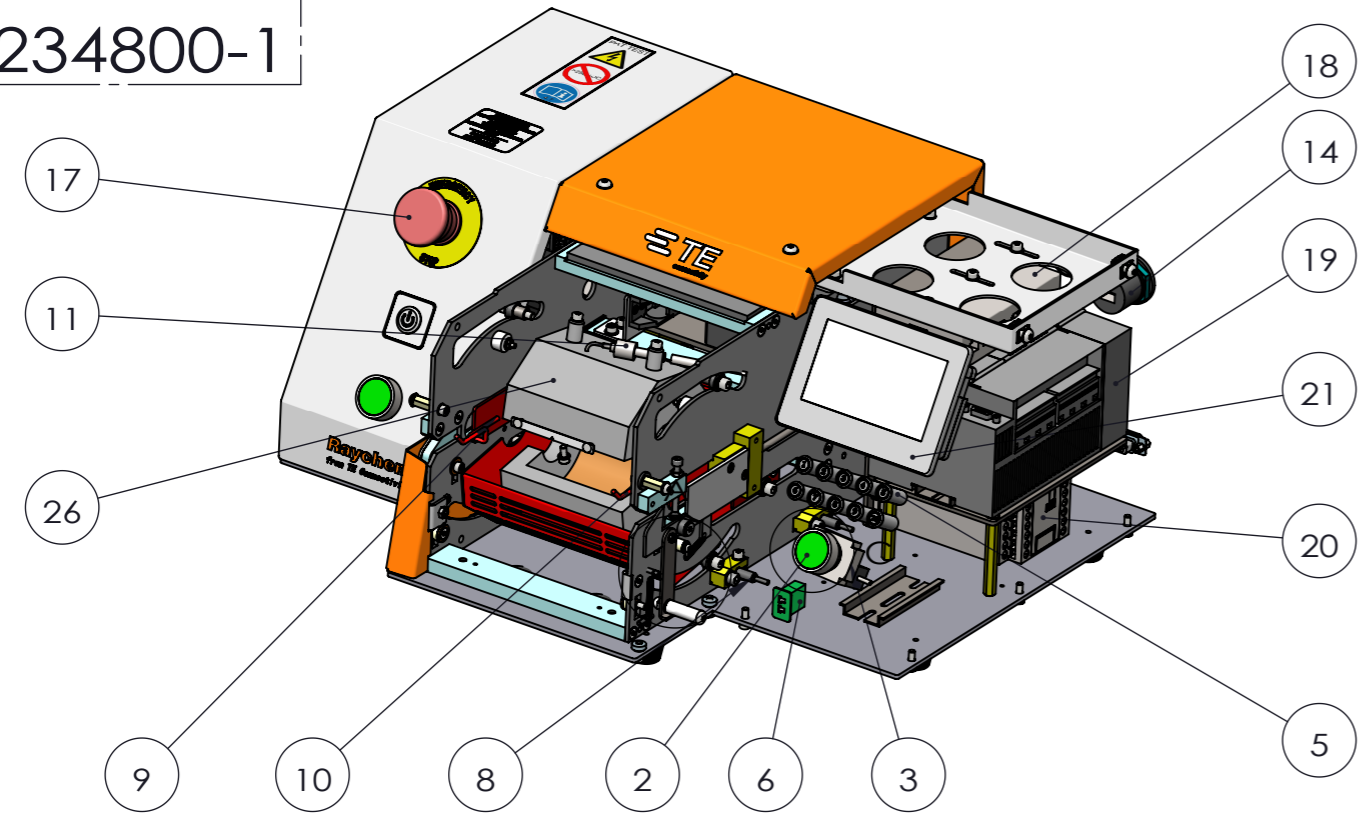

DETAIL C
SCALE 1 : 1.5

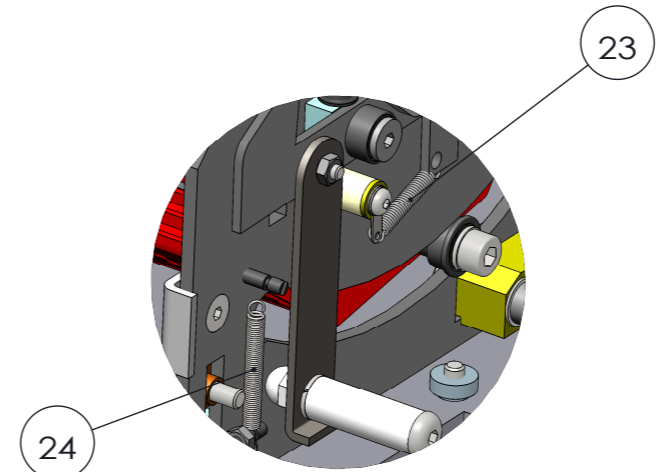
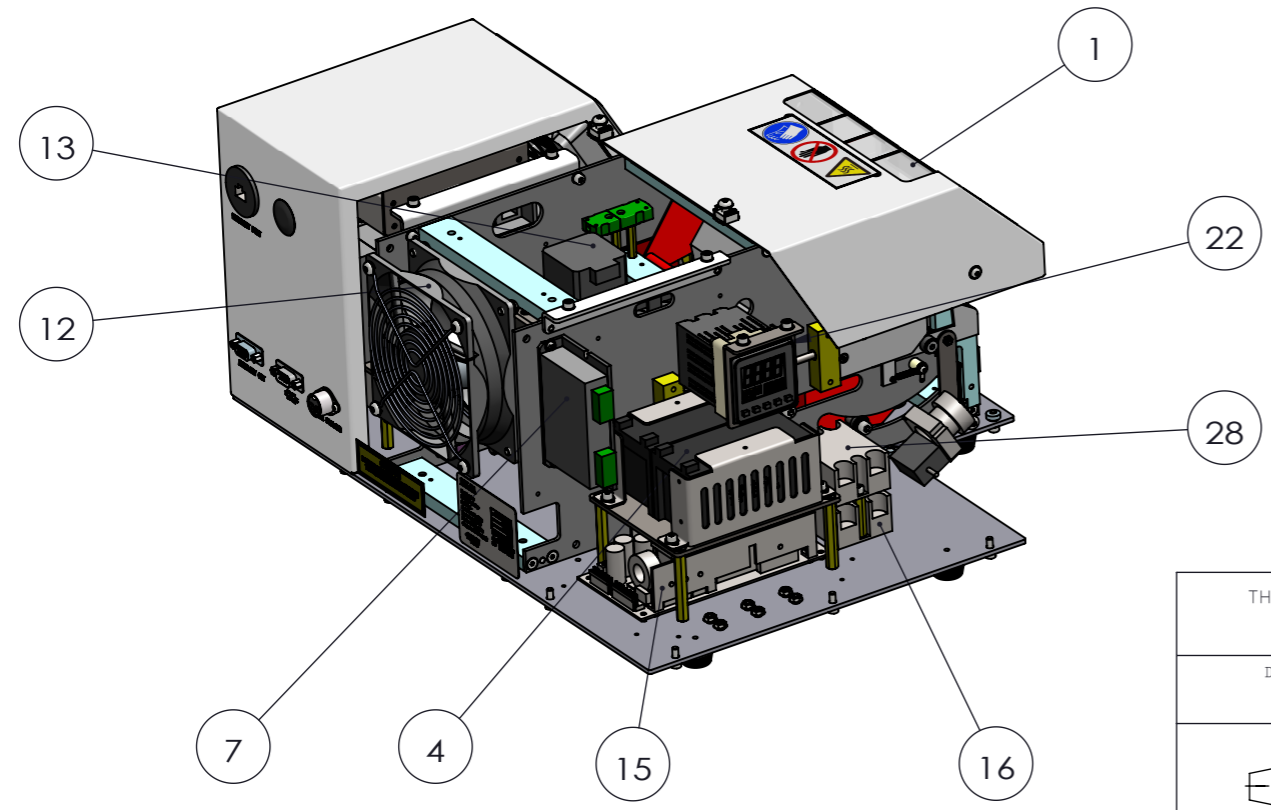

DETAIL A
SCALE 1 : 1.5

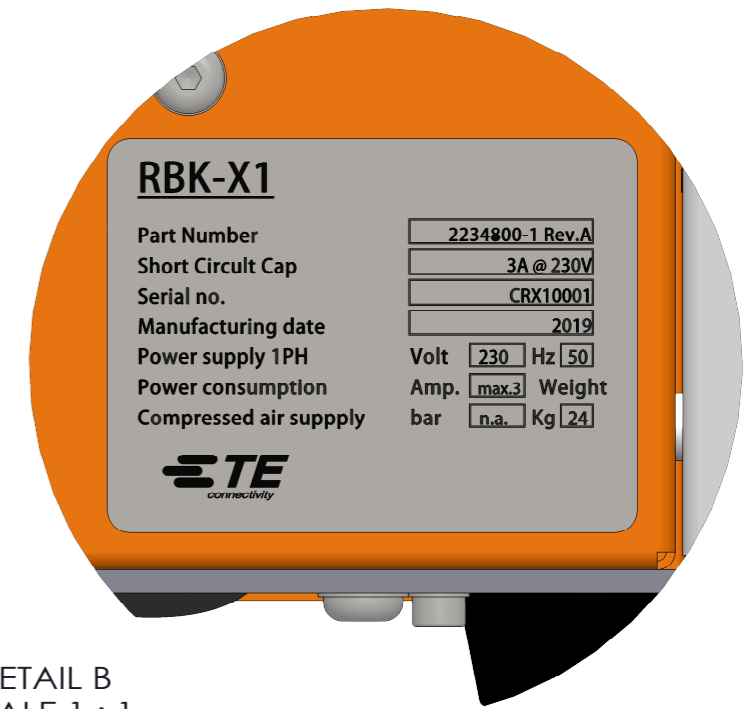

DETAIL B
SCALE 1 : 1

THIS DRAWING IS A CONTROLLED DOCUMENT.		DWN	C.ZHU	14AUG19	 TE Connectivity	
DIMENSIONS: mm		CHK				
TOLERANCES UNLESS OTHERWISE SPECIFIED:		APVD			NAME	
0 PLC	±	PRODUCT SPEC	SEE FIRST USED		RBK-X1 HEAT SHRINK MACHINE	
1 PLC	±	APPLICATION SPEC	-		SIZE	A3
2 PLC	±	WEIGHT	-		CAGE CODE	
3 PLC	±				DRAWING NO	C=2234800
4 PLC	±				RESTRICTED TO	
ANGLES	-	CUSTOMER DRAWING	SCALE	1:5	SHEET	2 OF 4
MATERIAL	-				REV	A

PART NUMBER	REV	FIRST USED	TYPE
2234800-1	A	-	STANDARD
2234800-2	A	-	CE VERSION

REVISIONS					
P	LTR	DESCRIPTION	DATE	DWN	APVD
	A	INITIAL RELEASE	14AUG19	CZ	

2234800-2

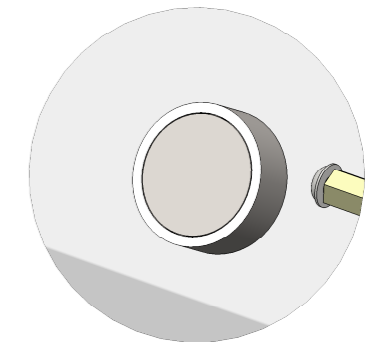
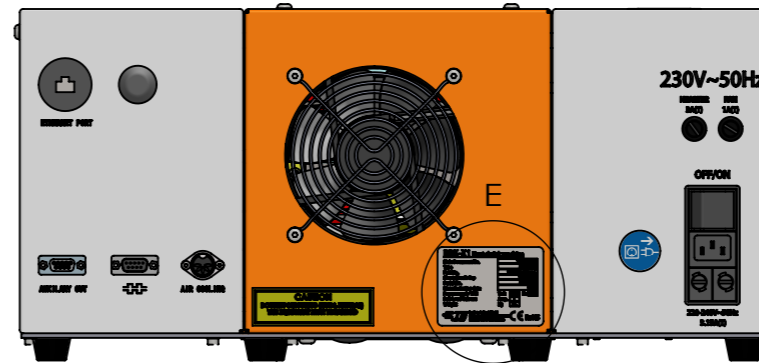
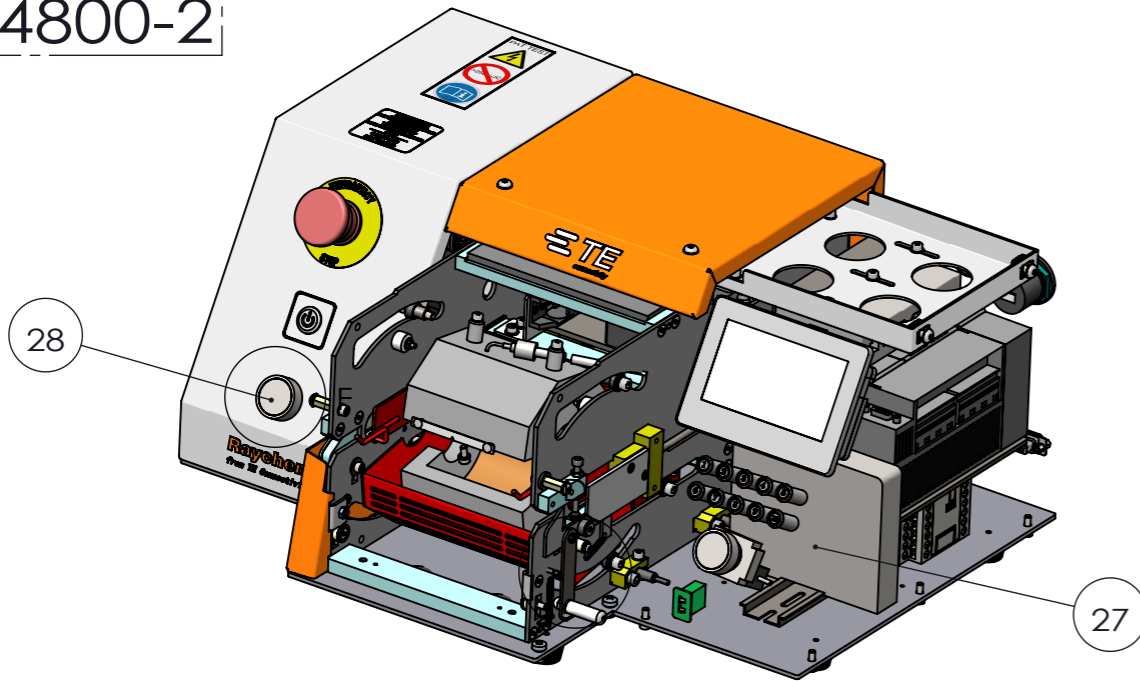

DETAIL F
SCALE 1 : 1.5

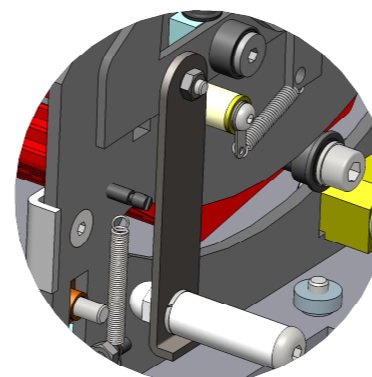
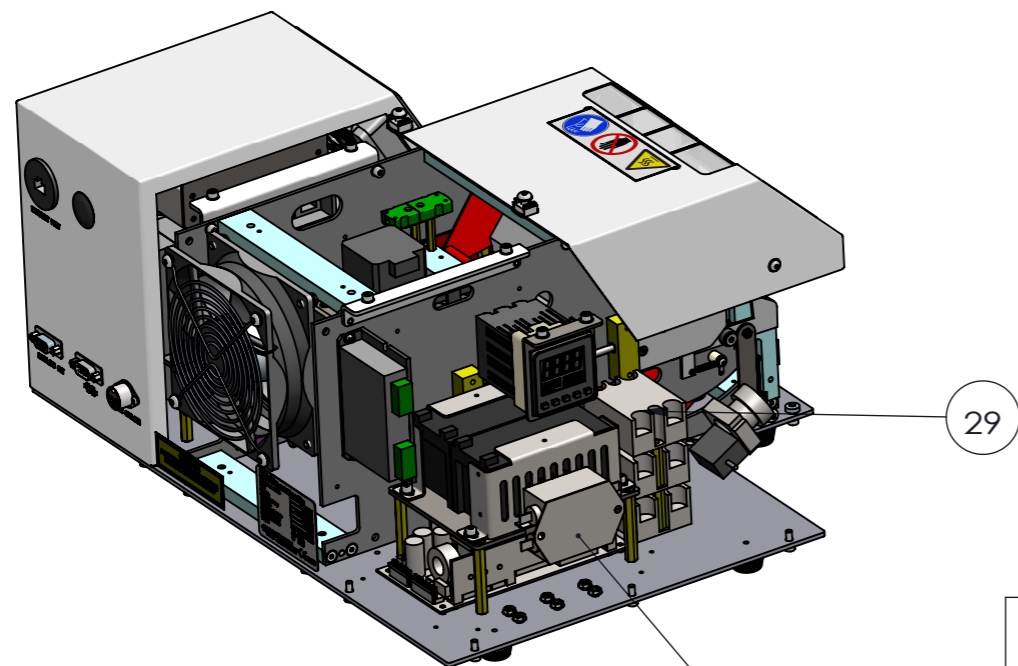

DETAIL D
SCALE 1 : 1.5



DETAIL E
SCALE 1 : 1

RBK-X1 Heat shrink machine	
Main Document No.	2234783-2
Type	RBK-X1 CE
Part No.	2234800-2 Rev.A
Short Circuit Cap	3A @ 230V
Serial No.	CRX10000
Manufacturing date	2019
Power supply 1PH	Volt 230 Hz 50/60
Full-Load Current	Amp. 3
Weight	Kg 24

Tyco Electronics (Shanghai) Co., Ltd
 FIG#H Section, 1/F, Building 15, 999 Yingjun Road
 (Shanghai) Pilot Free Trade Zone, China

30

THIS DRAWING IS A CONTROLLED DOCUMENT.		DWN	C.ZHU	14AUG19	TE Connectivity		
		CHK					
DIMENSIONS: mm		APVD			NAME RBK-X1 HEAT SHRINK MACHINE		
TOLERANCES UNLESS OTHERWISE SPECIFIED: 0 PLC ± 1 PLC ± 2 PLC ± 3 PLC ± 4 PLC ± ANGLES ±		PRODUCT SPEC	SEE FIRST USED				
MATERIAL -		APPLICATION SPEC	-		SIZE	A3	
FINISH -		WEIGHT	-		CAGE CODE		
		CUSTOMER DRAWING		DRAWING NO	C=2234800		
		SCALE	1:5	SHEET	3 OF 4	REV	A

PART NUMBER	REV	FIRST USED	TYPE
2234800-1	A	-	STANDARD
2234800-2	A	-	CE VERSION

REVISIONS					
P	LTR	DESCRIPTION	DATE	DWN	APVD
	A	INITIAL RELEASE	14AUG19	CZ	

SPARE PARTS LIST

ITEM NO	QTY (STANDARD)	QTY (CE)	TE/PN	DESCRIPTION
1	1	1	2234897-1	VIEW WINDOW
2	2	-	2234980-1	START BUTTON(GREEN)
3	2	2	2234984-1	CONTACT,START BUTTON
4	2	2	2234971-1	STORAGE BATTERY
5	10	10	2234981-X	PROCESS SLECTION BUTTON(X=BUTTON NUMBER,1.2.....)
6	1	1	2234973-1	"K"TYPE SOCKET
7	1	1	2234972-1	MOTOR DRIVER
8	2	2	2234988-1	PROXIMITY SENSOR
9	1	1	2234840-1	EJECTOR BLADE LEFT
10	1	1	2234840-2	EJECTOR BLADE RIGHT
11	1	1	2234990-1	THERMOCOUPLE
12	1	1	2234963-1	COOLING FAN
13	1	1	2234883-1	STEPPER MOTOR
14	1	1	2234887-1	CONNECTOR,ETHERNET
15	1	1	2234970-1	24V POWER SUPPLIER
16	1	1	2234969-1	SOLID STATE RELAY
17	1	1	2234983-1	EMERGENCY STOP BUTTON
18	1	1	2234985-1	SWITCH
19	1	1	2234964-1	PLC
20	1	1	2234967-1	SAFETY REPLY
21	1	1	2234977-1	HUMAN MACHINE INTEFACE
22	1	1	2234968-1	TEMPERATURE CONTROLLER
23	2	2	2234868-1	RESET SPRING,LATCH ASSEMBLY
24	2	2	2234869-1	RESET SPRING,PINCH BLOCK
25	1	1	2234978-1	INLET, INCLUDES TWIN FUSEHOLDER,DOUBLE POLE SWITCH
26	1	1	2234991-1	HEATING ELEMENTS MOUDLE
27	-	1	2234967-2	TWO HANDED MOUDLE(FOR CE VERSION)
28	-	2	2234980-2	START BUTTON,CYCLE START PUSH BUTTON(WHITE)
29	1	2	2234969-2	SOLID STATE RELAY
30	-	1	2234995-2	WAVE FILTER

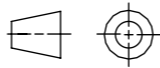
THIS DRAWING IS A CONTROLLED DOCUMENT.		DWN	C.ZHU	14AUG19	 TE Connectivity	
DIMENSIONS: mm		CHK				
		TOLERANCES UNLESS OTHERWISE SPECIFIED:		NAME		
MATERIAL		0 PLC	±	RBK-X1 HEAT SHRINK MACHINE		
		1 PLC	±	SIZE		
		2 PLC	±	CAGE CODE		
		3 PLC	±	DRAWING NO		
		4 PLC	±	RESTRICTED TO		
		ANGLES	±	A3		
		FINISH	-	C=2234800		
			-	SCALE 1:5		
			-	SHEET 4 OF 4		
			-	REV A		
CUSTOMER DRAWING						