



NOTE

All numerical values are in metric units [with U.S. customary units in brackets]. Dimensions are in millimeters [and inches]. Unless otherwise specified, dimensions have a tolerance of ± 0.13 [$\pm .005$] and angles have a tolerance of $\pm 2^\circ$. Figures and illustrations are for identification only and are not drawn to scale.

1. INTRODUCTION

This instruction sheet covers the use of the Water Proof Signal Double Lock connector system. Instructions for contact and housing assembly procedures and seal assembly procedures are included. Application Specification 114-143067 provides the requirements for application, including wire size range, contact crimp requirements.



NOTE

The listing of a drawing or part number in this specification should not be interpreted as an indication of availability. Contact the TE Product Information Center at the number at the bottom of page 1 for product availability.

2. CONNECTOR ASSEMBLY

2.1. Applications

A. Cap (Panel Mount)

Configurations for sealed panel mount cap applications are shown in Figure 1.

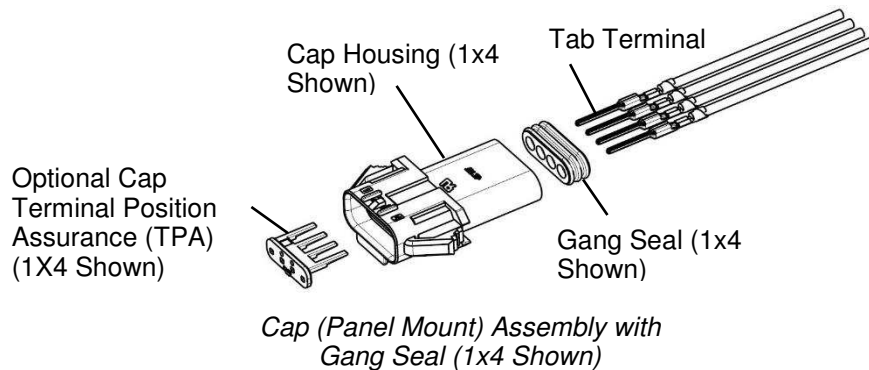

HOUSING(a)	POSITION	TAB TERMINAL(a)	SEALS		TPA
			Gang(b)	PERIMETER	
2321926-X	2-8	2321928-1	2321922-X	2321920-X	2321927-X



NOTE

- (a) See Application Specification 114-143067 for wire sizes, insulation diameter range, and crimping information for terminals.
- (b) Gang seal selection requires a single seal of the corresponding position and configuration for the housing.

Figure 1

B. Twist-N-Lock

Configurations for Twist-N-Lock Plug applications are show in Figure 2.

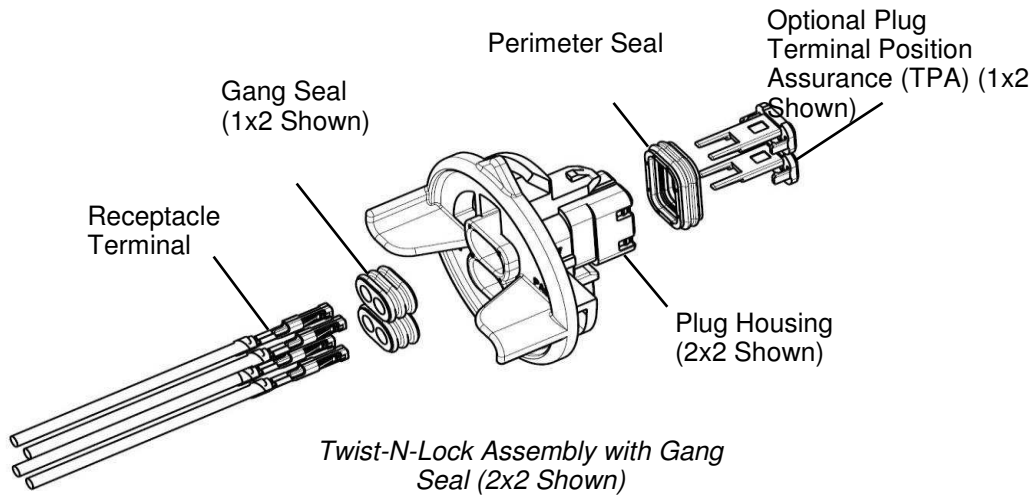

HOUSING(a)	Panel Thickness	POSITION	RECEPTACLE TERMINAL(a)	SEALS		TPA
				Gang(b)	PERIMETER	
2366250-X	0.75-1.36	4,6,12	2321921-1	2321922-Z	2329542-X	2321919-X
2366251-X	2.16-2.67	4,6,12	2321921-1	2321922-Z	2329542-X	2321919-X



NOTE

- (a) See Application Specification 114-143067 for wire sizes, insulation diameter ranges, and crimping information for terminal.
- (b) Assembly requires two or three gang seals in two or three row housing respectively. See Customer Drawing for applicable dash number (-Z) based on number of positions.

Figure 2

C. Cap

Configurations for sealed free hanging cap applications are shown in Figure 3.

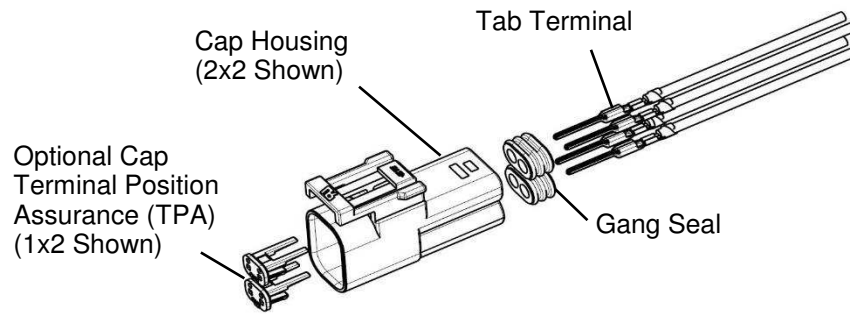

Cap (Free Hanging) Assembly with Gang Seal (2x2 Shown)

HOUSING(a)	POSITION	TAB TERMINAL(a)	SEALS(b)	TPA
			Gang	
2321924-X	2-8	2321928-1	2321922-Z	2321927-X
2366249-X	4,6,12	2321928-1	2321922-Z	2321927-X



NOTE

- (a) See Application Specification 114-143067 for wire sizes, insulation diameter range, and crimping information for terminal.
- (b) The gang seal selection requires one, two, three in one, two, three row housing respectively. See customer drawing for applicable dash number (-Z) based on number of positions.

Figure 3

D. Plug

Configurations for plug applications are shown in Figure 4.

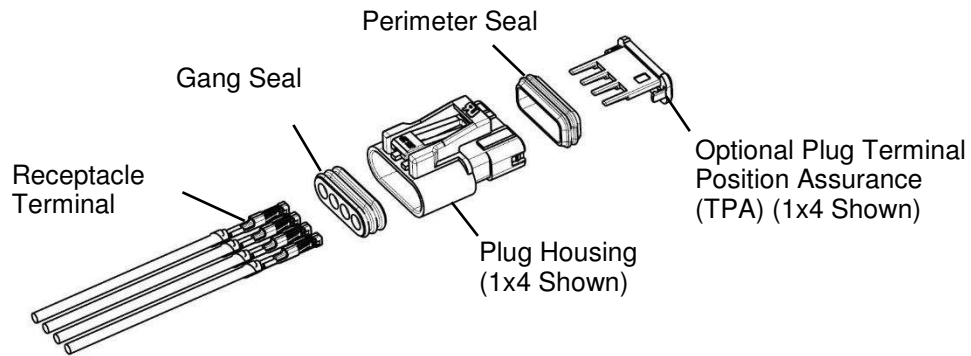

*Plug Assembly with Gang Seals
(1x4 Shown)*

HOUSING(a)	POSITION	RECEPTACLE TERMINAL(a)	SEALS		TPA
			Gang (b)	Perimeter	
2321918-X	2-8	2321921-1	2321922-X	2321920-X	2321919-X



NOTE

- (a) See Application Specification 114-143067 for wire sizes, insulation diameter range, and crimping information for terminal.
- (b) The gang seal selection requires a single seal of the corresponding position and configuration for the housing.

Figure 4

3. SEAL ASSEMBLY PROCEDURE

3.1. Gang Seal Assembly

1. Select appropriate contacts, then follow termination procedures shown in Application Specification 114-143067.
2. Insert the gang seal into the contact cavity at the back end (wire side) of the cap and plug housings as shown in Figure 5. Push seal into the contact cavity until it bottoms in the housing.

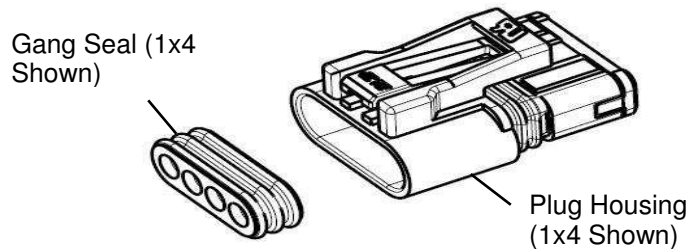

Figure 5

3. Align the terminated tab or receptacle contact with the appropriate cavity at the back end (wire side) of the plug or cap housing. This alignment is to help ensure that the gang seal will not be damaged during the insertion process. See Figure 6.

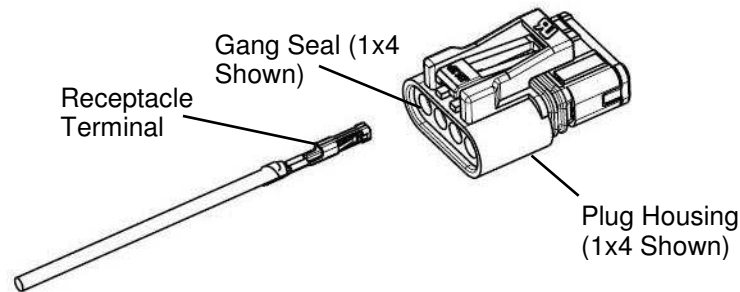

Figure 6

4. Grasp the wire directly behind the insulation barrel and push the contact straight into the housing cavity until contact locks in place. See Figure 7.



CAUTION

Care must be taken to avoid nicks, tears, or other damage to gang seal when inserting contact.

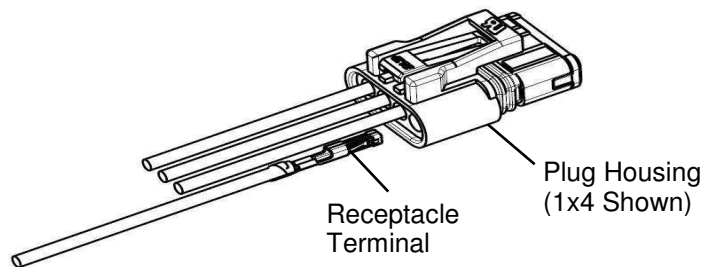

Figure 7

3.2. Perimeter Seal Assembly

1. Assemble Perimeter seal over contact silos of the plug housing as shown in Figure 8 until it rests against the mating face of the plug housing as shown in Figure 9.

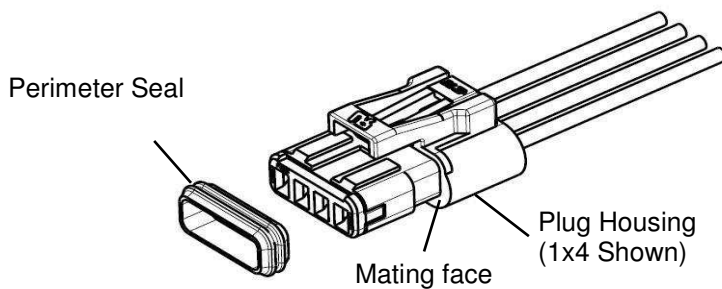

Figure 8

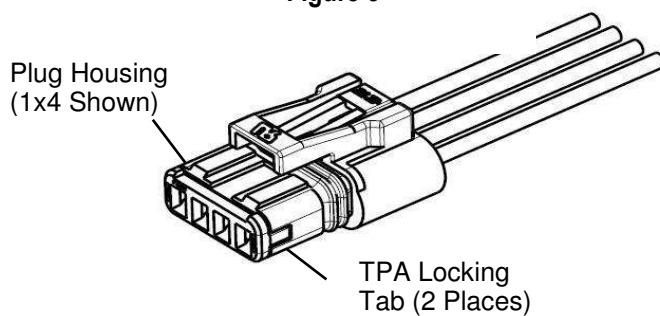
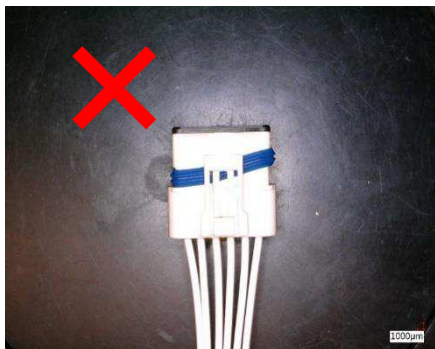
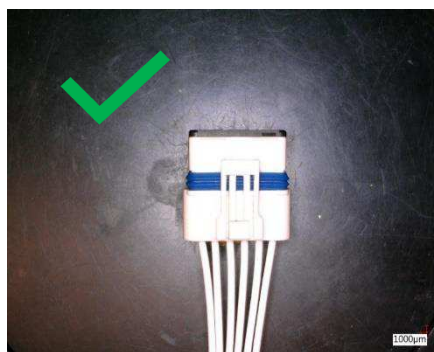

Figure 9

4. ILLUSTRATIONS OF SEAL ASSEMBLY

4.1. Perimeter Seal



4.2. Rear Seal

