

P.C.B. LAYOUT

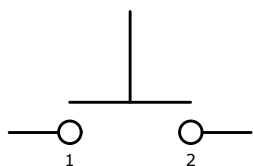

SCHEMATIC

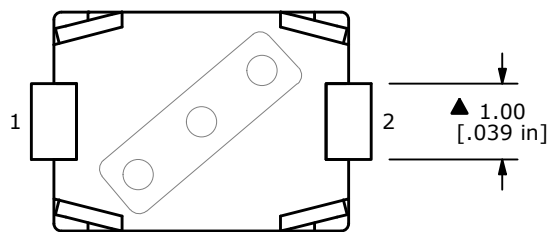
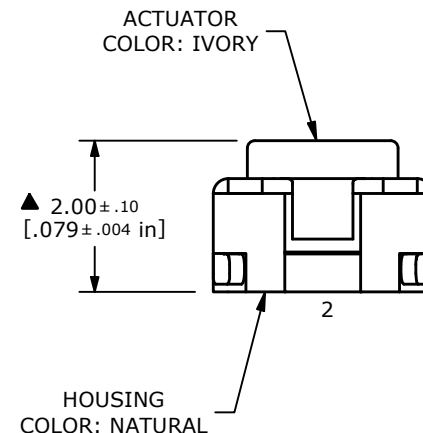
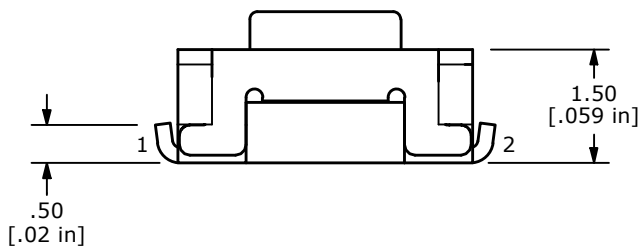
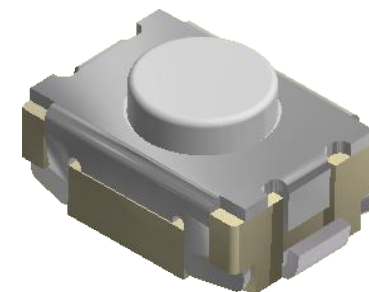
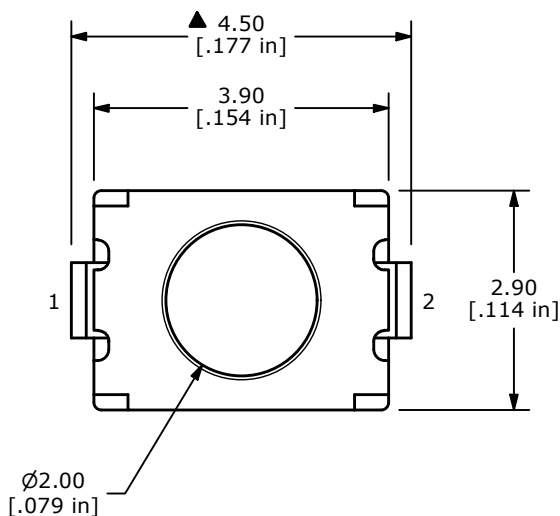

NOTES:

1. ALL DIMENSIONS IN MM
2. GENERAL TOLERANCE: X.X = ±0.4
X.XX = ±0.25
3. TERM. NUMBERS FOR REFERENCE ONLY.
4. RATING: 12VDC, 50mA
- ▲ 5. OPERATING FORCE: 160 ±50 gms
6. TRAVEL: 0.2mm ±0.1mm
7. CONTACT RESISTANCE: 100 MILLI OHMS MAX. (INITIAL)
8. MECHANICAL/ELECTRICAL LIFE 200,000 CYCLES MIN.
9. PACKAGE: TAPE AND REEL - 2500 PIECES PER REEL
10. ▲ DENOTES CRITICAL PARAMETER

G	24272	update model	4/20/20	MW
F	23507	remove ROHS note, info on website	7/30/18	MW
E	23294	UPDATED LAYOUT	4/13/18	MJR
D	21622	ADDED HOUSING COLOR	10/14/14	AS
REV	PCR NO	DESCRIPTION	DATE	BY



TITLE TL1015AF160QG

THE INFORMATION CONTAINED IN THIS DOCUMENT IS PROPRIETARY TO E-SWITCH AND IS NOT TO BE COPIED OR TRANSFERRED

SCALE	DATE	DR	DWG	REV
10:1	2/1/2013	rc	P420000	G