

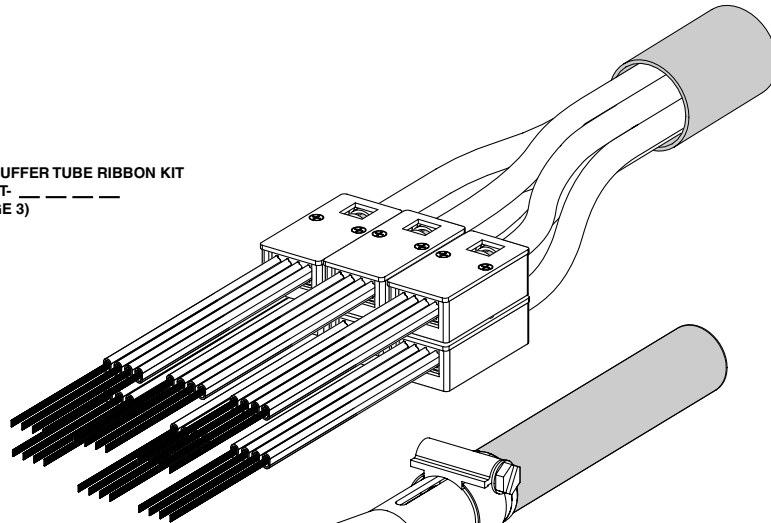

# Ribbon Blocking Kit Installation Instructions

LOOSE BUFFER TUBE RIBBON KIT  
BLK-RLBT- \_\_\_\_\_  
(SEE PAGE 3)



CENTRAL OVAL TUBE RIBBON KIT  
BLK-RCT- \_\_\_\_\_  
(SEE PAGE 12)

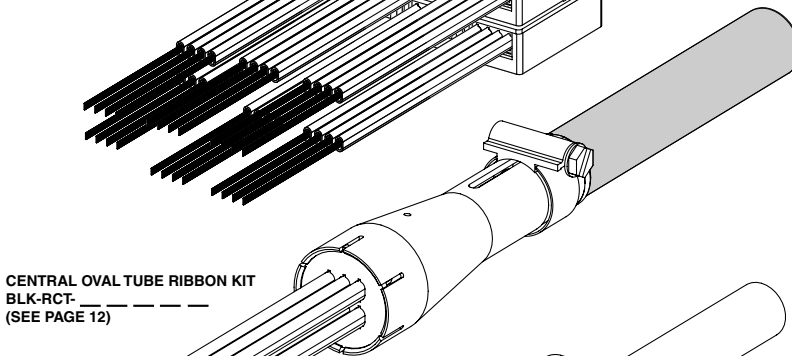

RIBBON CENTRAL TUBE KIT  
BLK-RCT- \_\_\_\_\_  
(SEE PAGE 20)

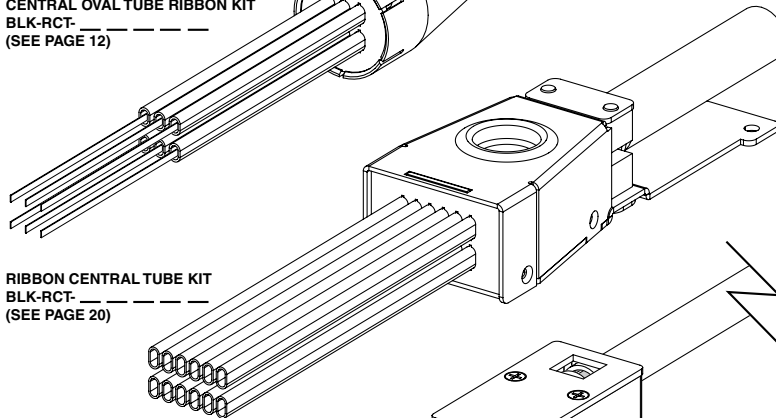

RIBBON IFC CABLE KIT  
BLK-RIFC- \_\_\_\_\_  
(SEE PAGE 27)

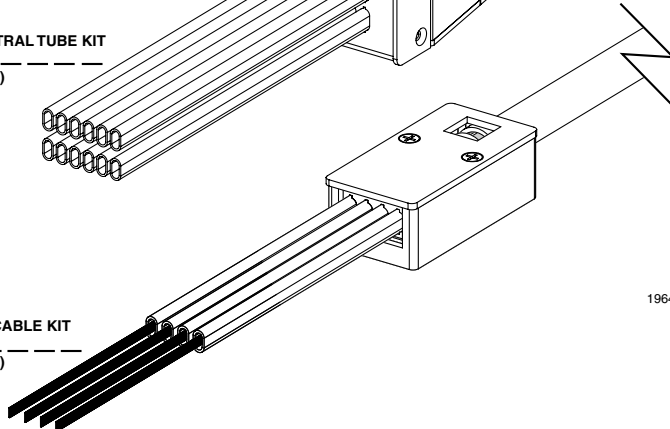

19645-A

## INTRODUCTION

This manual contains installation instructions for the following fiber ribbon blocking kits: Loose Buffer Tube Ribbon Kit (BLK-RLBT), Central Oval Tube Ribbon Kit (BLK-RCT), Ribbon Central Tube Kit (BLK-RCT), and the Ribbon IFC Cable Kit (BLK-RIFC).

Contents	Page
1 LOOSE BUFFER TUBE RIBBON KIT INSTALLATION .....	3
2 CENTRAL OVAL TUBE RIBBON KIT (BLK-RCT) .....	12
3 RIBBON CENTRAL TUBE KIT (BLK-RCT) .....	20
4 RIBBON IFC CABLE KIT (BLK-RIFC) .....	27
5 CUSTOMER INFORMATION AND ASSISTANCE .....	36

## Revision History

ISSUE	DATE	REASON FOR CHANGE
Issue 1	5/04	Original

## Trademark Information

ADC and ADC Telecommunications are registered trademarks of ADC Telecommunications, Inc.

## Admonishments

Important safety admonishments are used throughout this manual to warn of possible hazards to persons or equipment. An admonishment identifies a possible hazard and then explains what may happen if the hazard is not avoided. The admonishments — in the form of Dangers, Warnings, and Cautions — must be followed at all times. These warnings are flagged by use of the triangular alert icon (seen below), and are listed in descending order of severity of injury or damage and likelihood of occurrence.



**Danger:** *Danger is used to indicate the presence of a hazard that **will** cause severe personal injury, death, or substantial property damage if the hazard is not avoided.*



**Warning:** *Warning is used to indicate the presence of a hazard that **can** cause severe personal injury, death, or substantial property damage if the hazard is not avoided.*



**Caution:** *Caution is used to indicate the presence of a hazard that **will** or **can** cause minor personal injury or property damage if the hazard is not avoided.*

# 1 LOOSE BUFFER TUBE RIBBON KIT INSTALLATION

Figure 1 shows the Loose Buffer Tube Ribbon Kit (BLK-RLBT) catalog scheme.

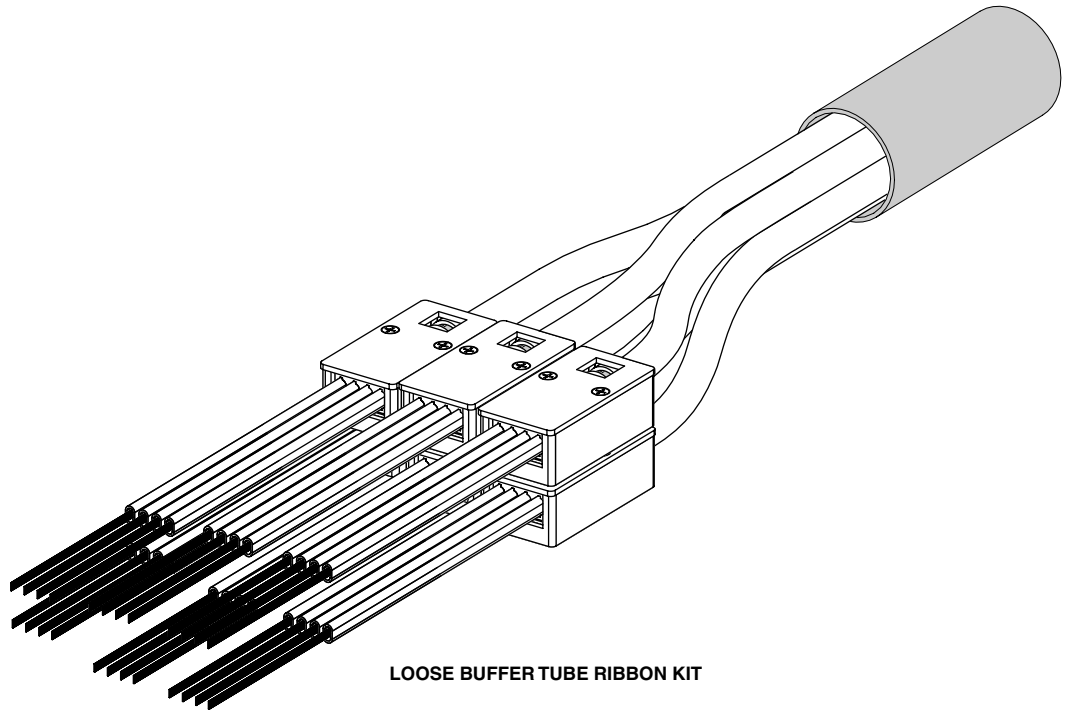

LOOSE BUFFER TUBE RIBBON KIT

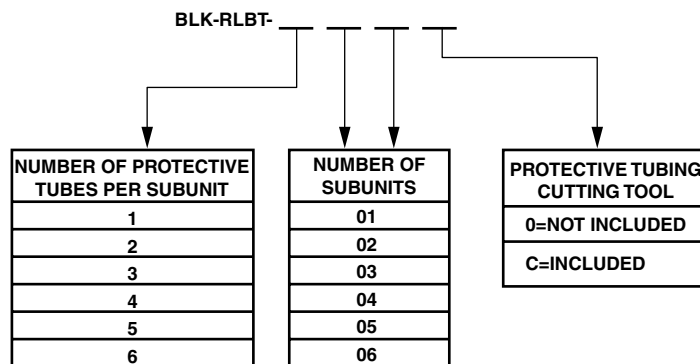

19646-A

Figure 1. Loose Buffer Tube Ribbon Kit Catalog Scheme

1. Strip the outer cable jacket to expose the inner subunits (Figure 2).
2. Strip subunit jackets to expose ribbon fiber (Figure 2). Cut strength member as shown.

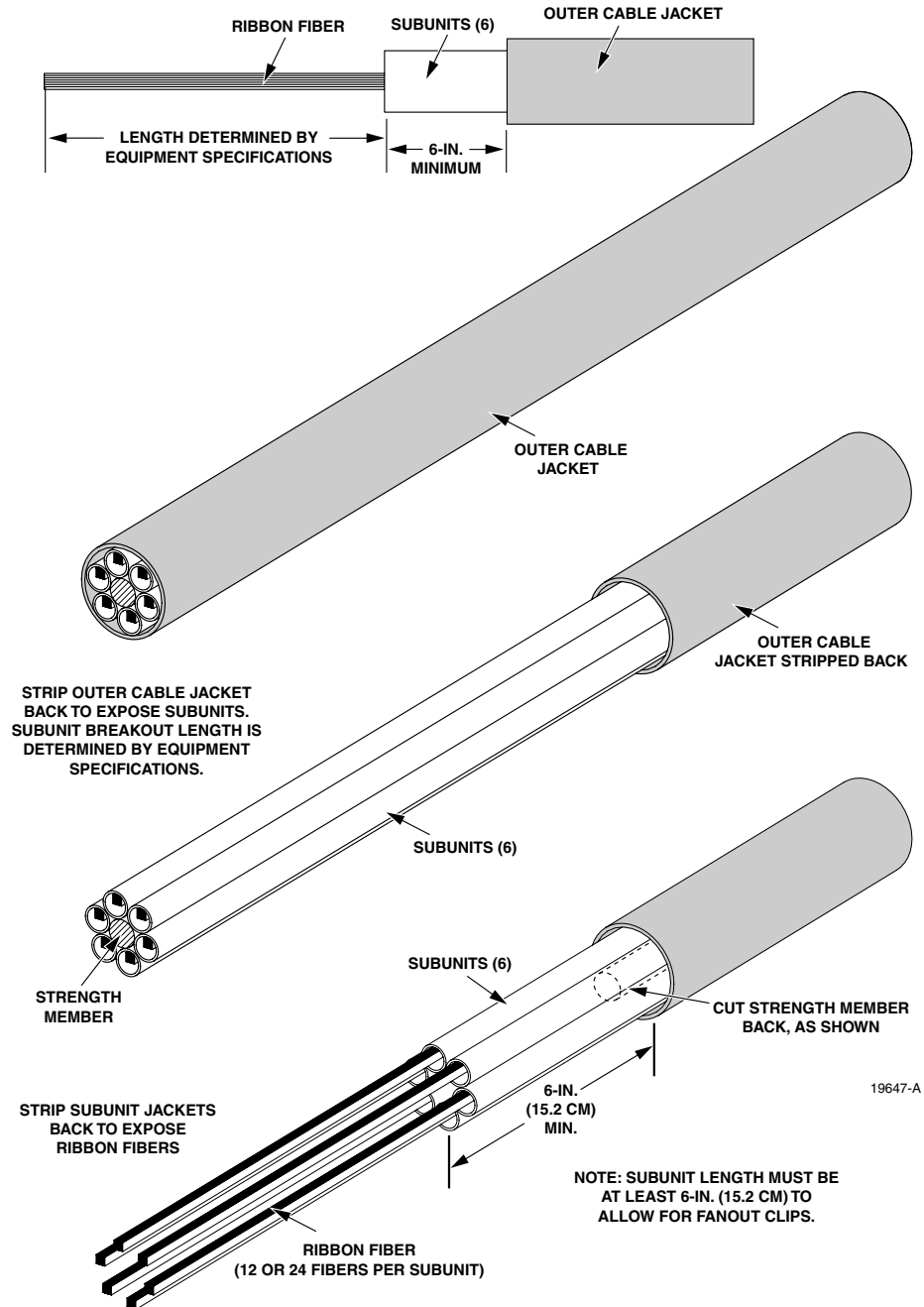
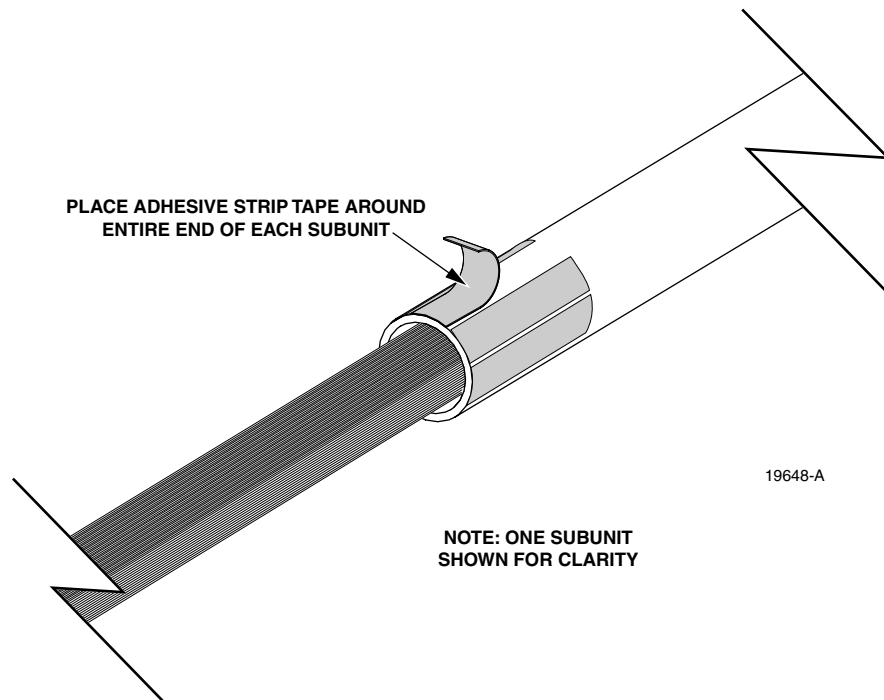

Figure 2. Strip Outer Cable Jacket and Subunit Jackets

3. Place adhesive strip tape (provided) around entire end of each subunit (Figure 3).

► **Note:** One subunit shown for clarity.

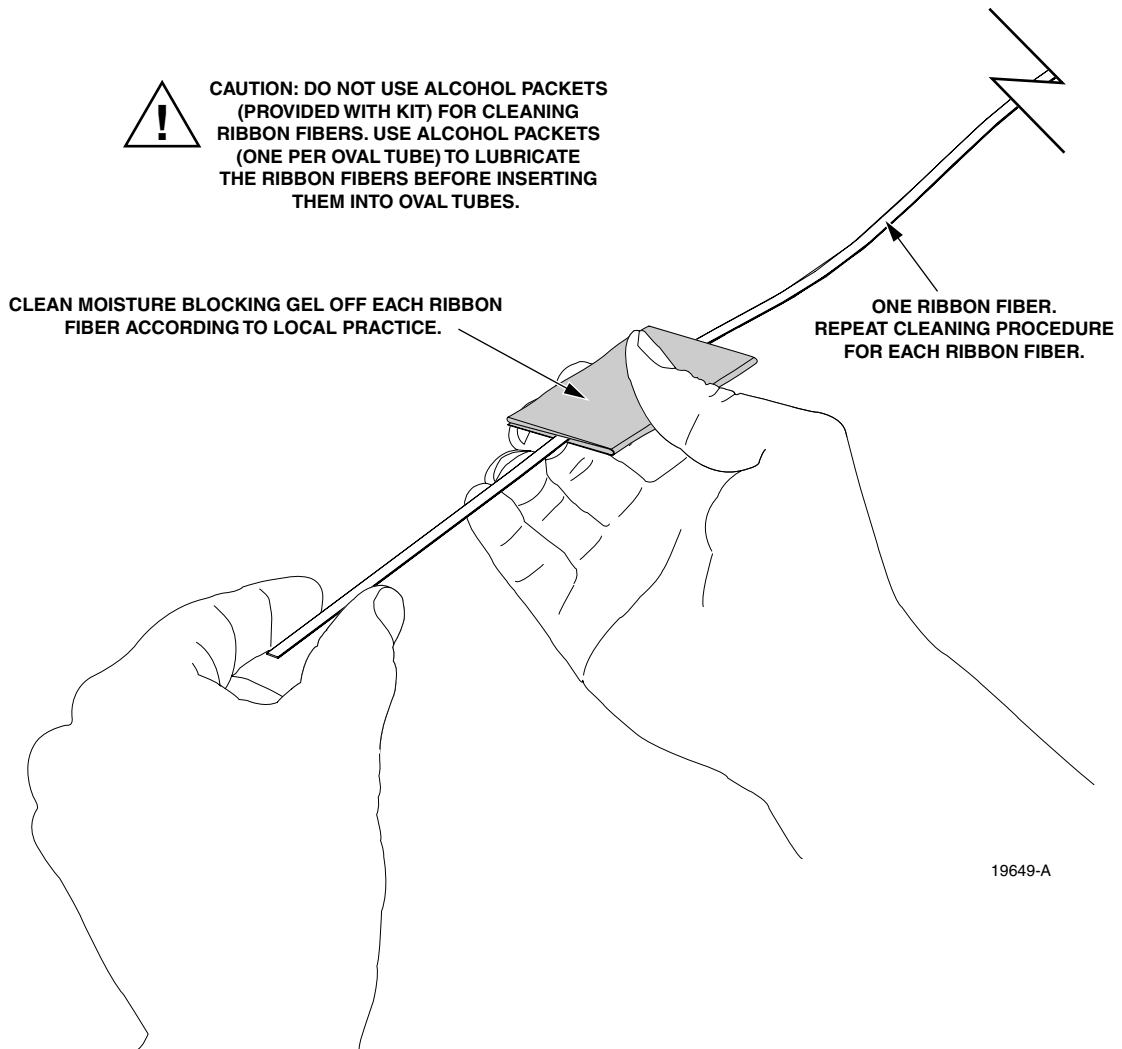

**Figure 3. Place Tape on End of Each Subunit**

4. Clean the moisture blocking gel off each ribbon fiber according to local practice (Figure 4).

**⚠ Caution:** Do not use alcohol packets (provided) for cleaning ribbon fibers, use the alcohol packets to lubricate the ribbon fibers before inserting them into the oval tubes.

5. After cleaning ribbon fibers, use alcohol wipes (one per oval tube) to lubricate the top and bottom of the ribbon fibers before inserting ribbon fibers into oval tube (Figure 4).



**Figure 4. Clean and Lubricate Ribbon Fibers**

6. Carefully feed ribbon fibers through oval tubes (Figure 5).
- ▶ **Note:** Feed up to six, 12-fiber ribbons into each tube at the same time.
  - ▶ **Note:** The oval tubes and retainer plate are shipped pre-assembled as shown.

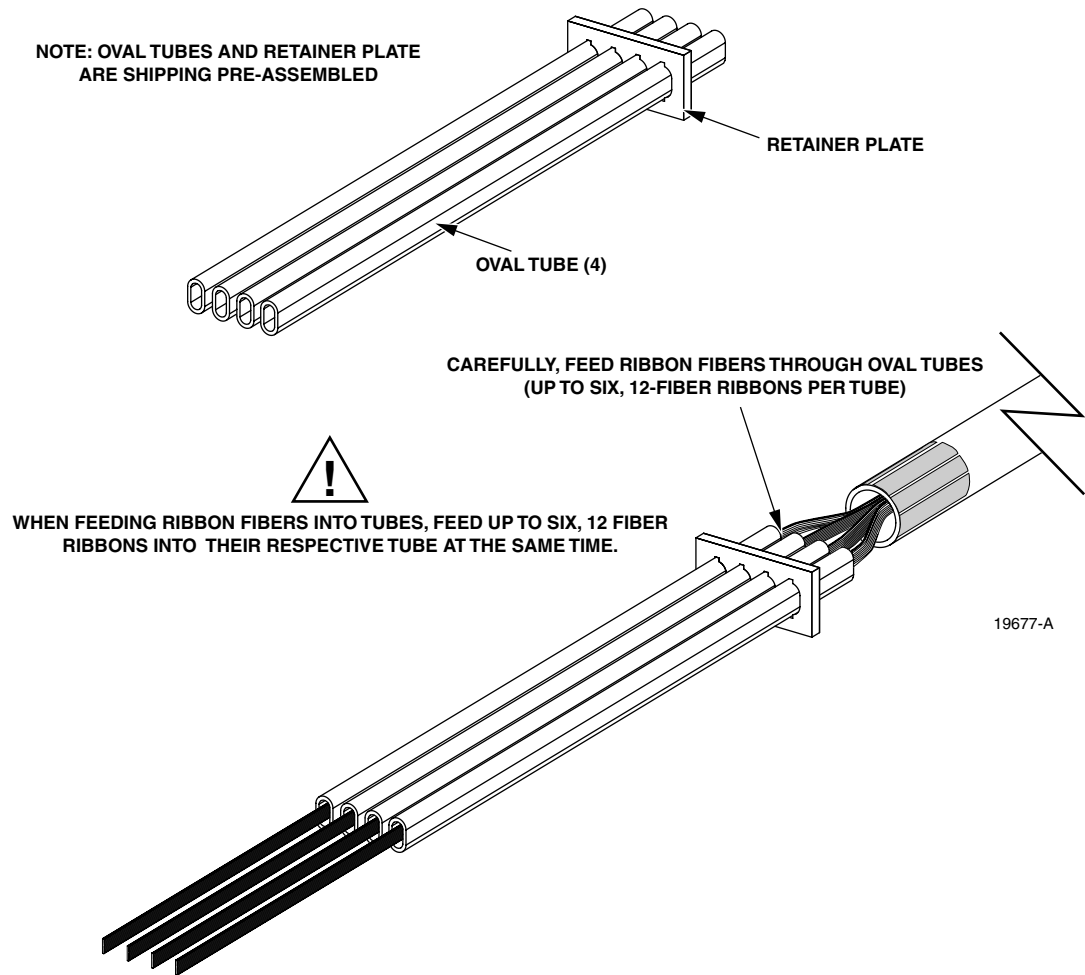
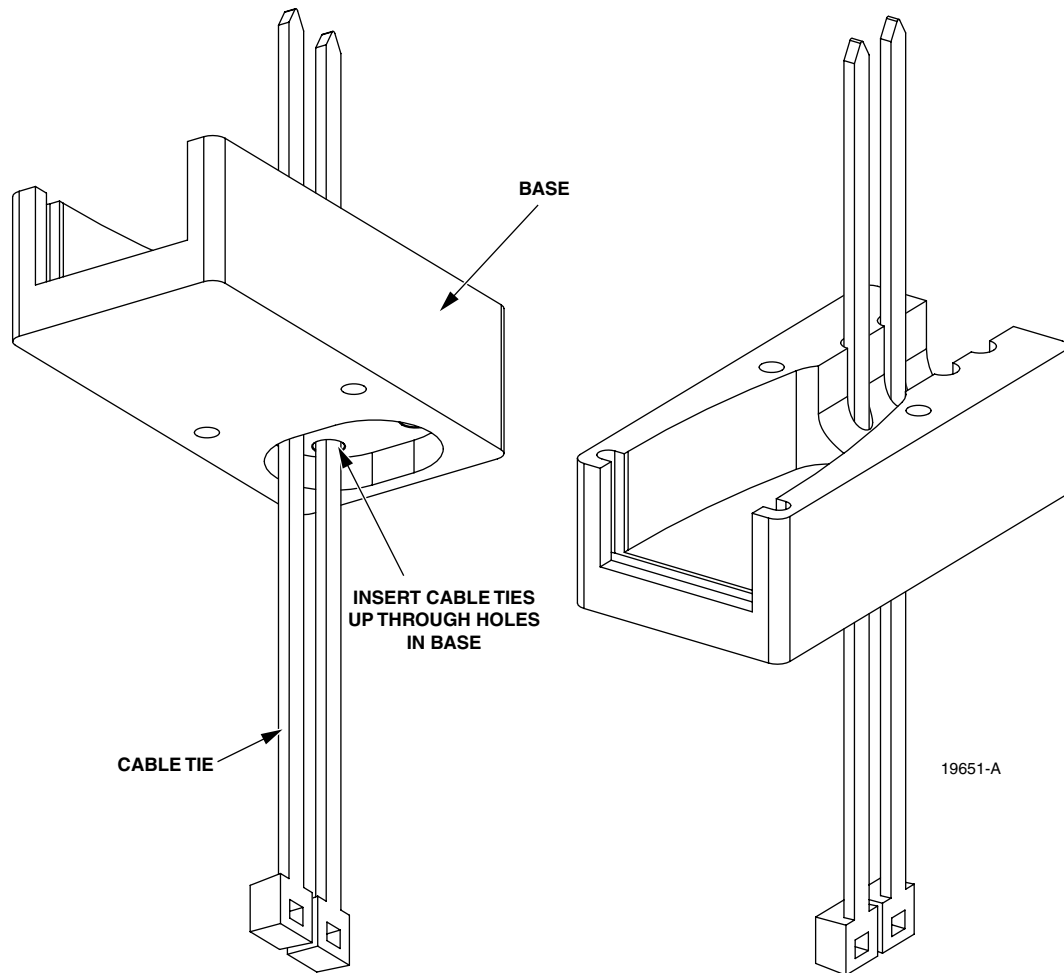

Figure 5. Insert Ribbon Fibers into Oval Tubes

7. Insert cable ties (2) up through holes in bottom of base (Figure 6).



**Figure 6. Insert Cable Tie into Base**

8. Align face plate with face plate pocket in base and place subunit assembly into base (Figure 7). Adjust subunit either forward or backward to the location shown in the lower view.

► **Note:** Subunit assembly includes subunit, ribbon fibers, face plate and oval tubes.

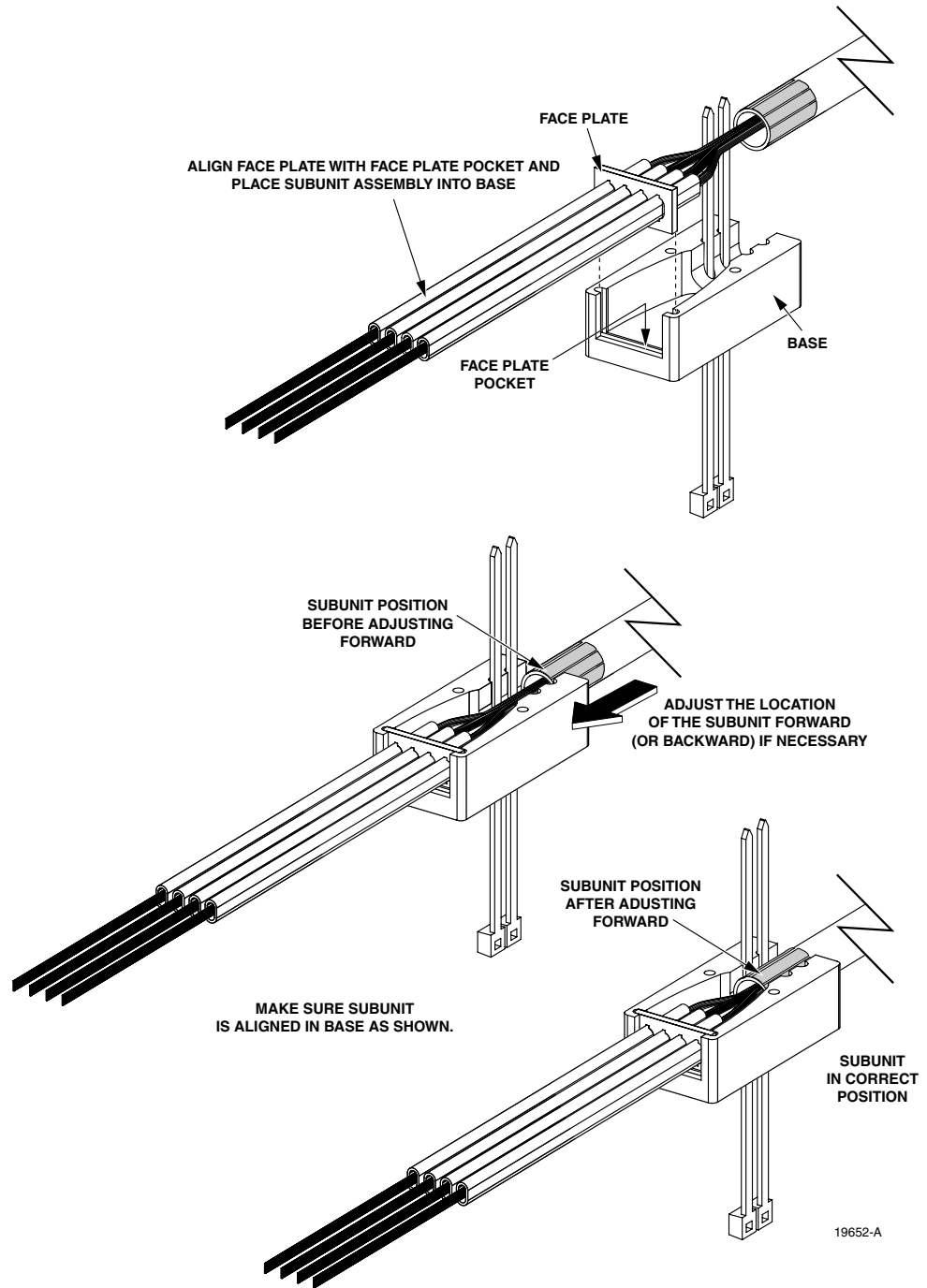

**Figure 7. Place Subunit Assembly into Fanout Base**

9. Route the cable tie around the subunit and down through the other side of the base (Figure 8). Cinch the cable tie and cut off excess portion.

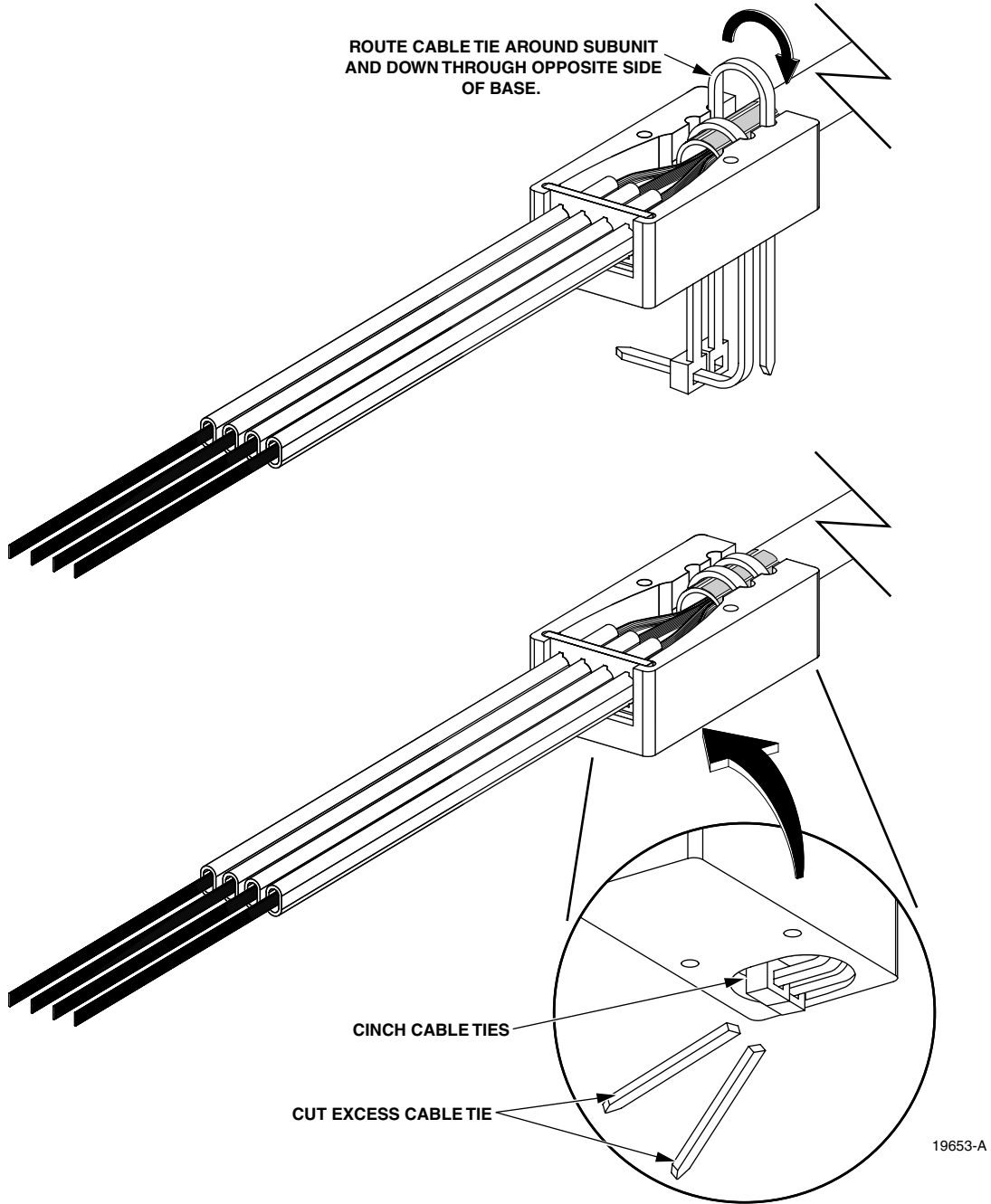

**Figure 8. Install Cable Ties (2)**

- Secure cover onto base using two screws (Figure 9).

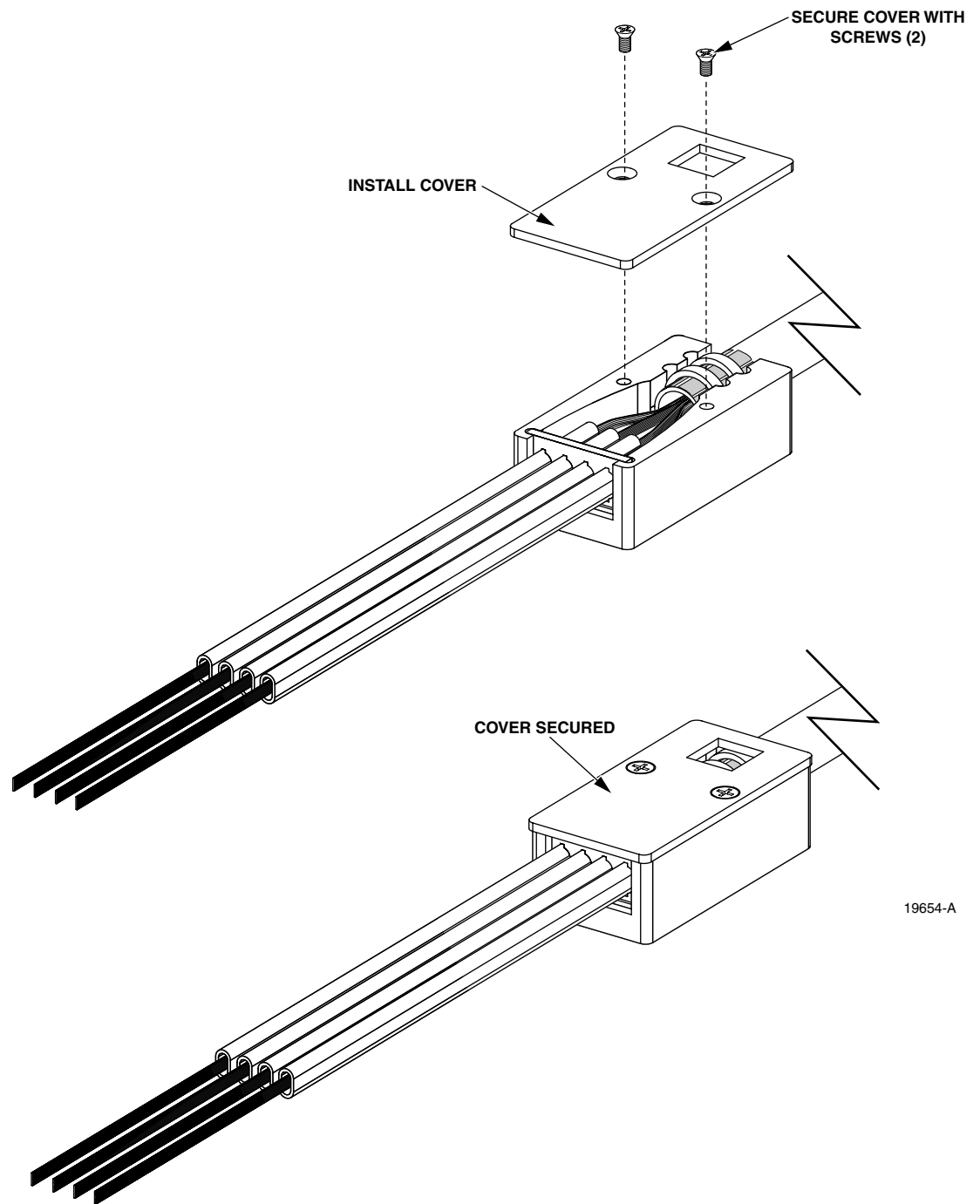

19654-A

**Figure 9. Install Top Cover onto Base**

## 2 CENTRAL OVAL TUBE RIBBON KIT (BLK-RCT)

Figure 10 shows the catalog scheme for the Central Oval Tube Ribbon Kit. ADC recommends using the Central Oval Tube Ribbon Kit for kits up to 12 protective tubes. For kits greater than 12 protective tubes, use the larger Ribbon Central Tube Kit (BLK-RCT). See Section 3, "Ribbon Central Tube Kit (BLK-RCT)."

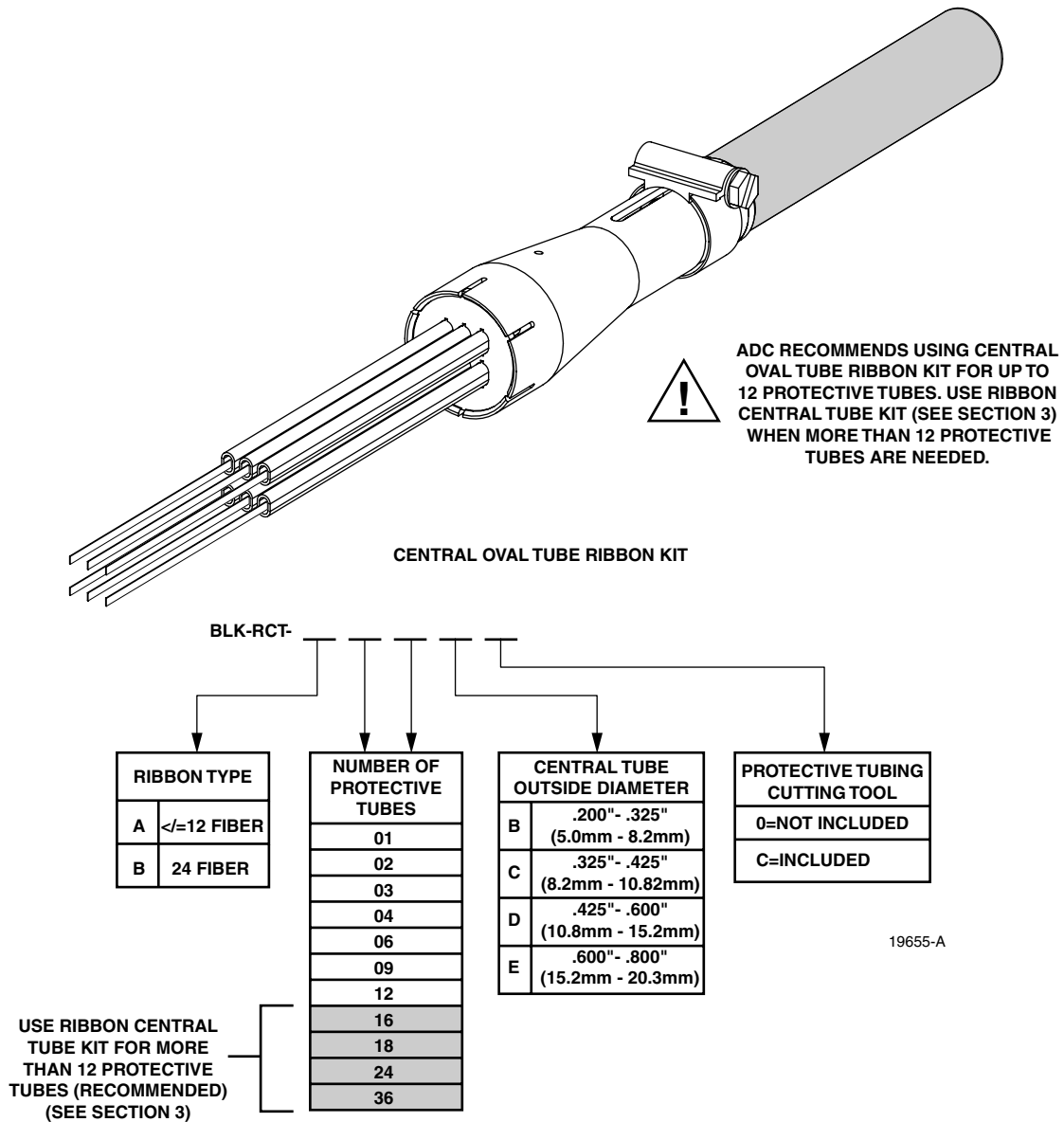

Figure 10. Central Oval Tube Ribbon Kit Catalog Scheme

1. Strip outer cable jacket to expose inner central tube (Figure 11). Trim strength members flush with outer cable jacket. Clean residue from outside of central tube to prevent slippage when block is attached.
2. Strip central tube back 1.5-inches (min) to expose bare ribbons. (Ribbon fiber length determined by equipment specifications.) Note: A maximum of 5 meters (16.4 feet) of bare fiber can be fed through an oval tube.

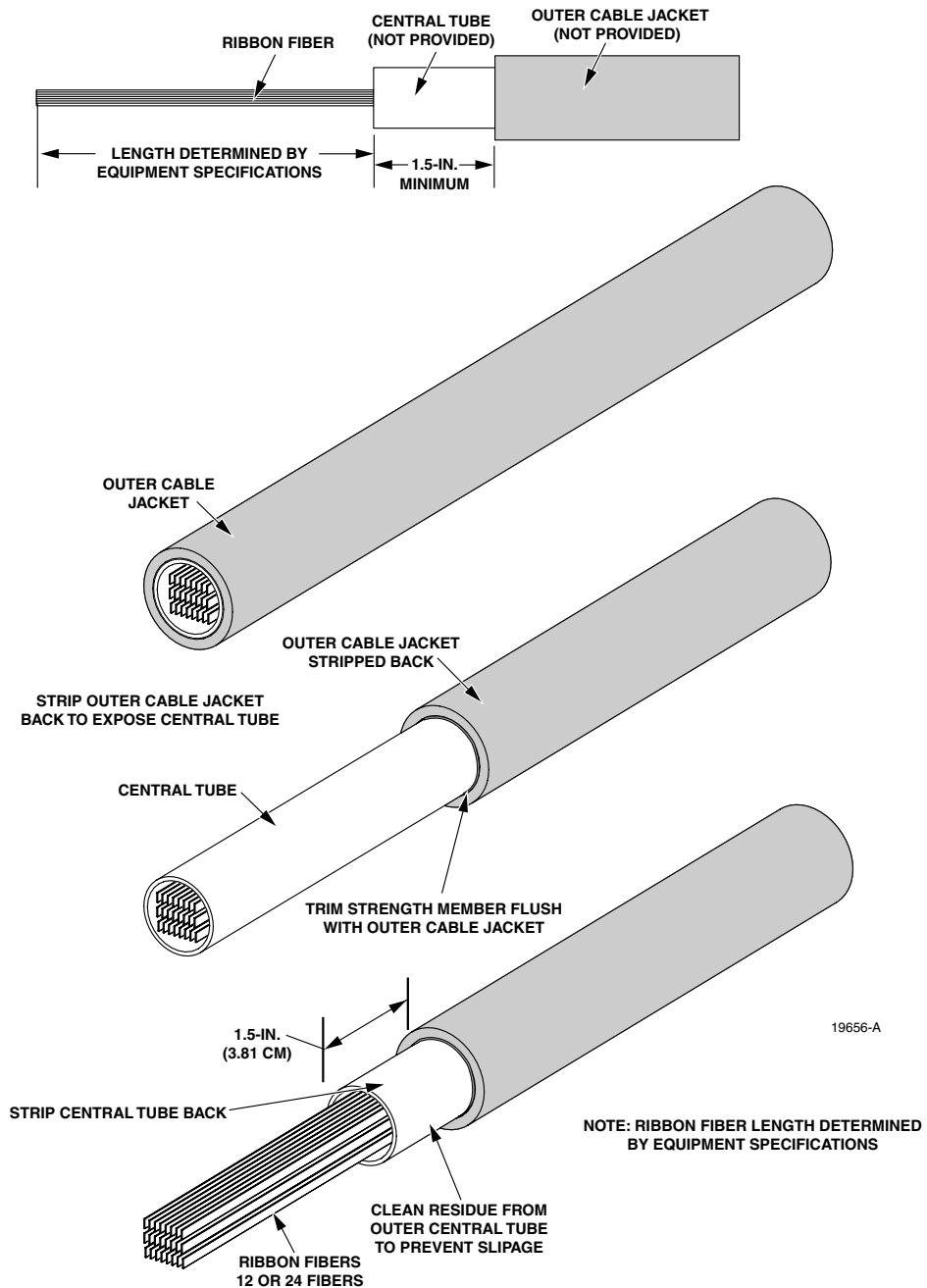
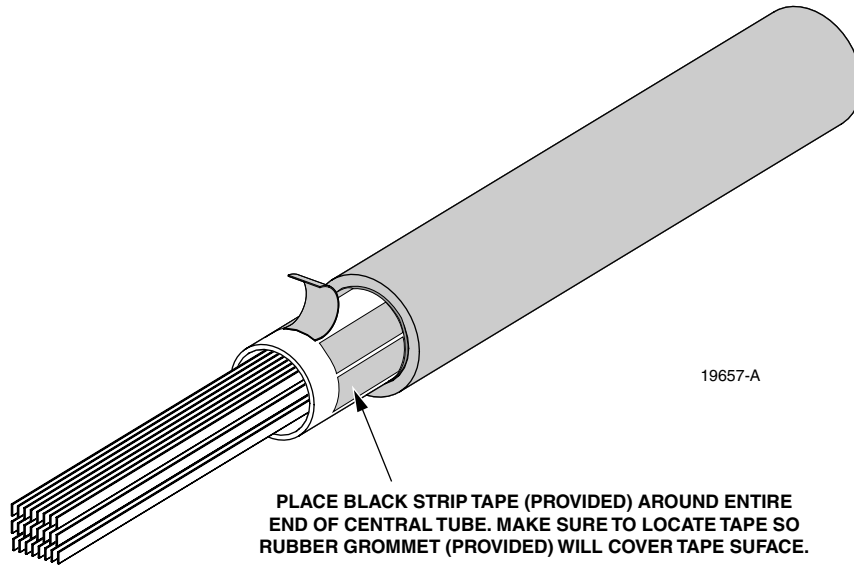

Figure 11. Breakout Ribbon Fibers

3. Place black strip tape (provided) around the entire end of the central tube (See Figure 12). Make sure to position tape so rubber grommet will cover tape.



**Figure 12. Place Adhesive Tape around End of Central Tube**

4. Select the thickest rubber grommet (supplied) that will fit between central tube and flare tube (Figure 13). Position over central tube making sure to cover tape surface.

► **Note:** This snug fit is critical when attaching flare tube to central tube.

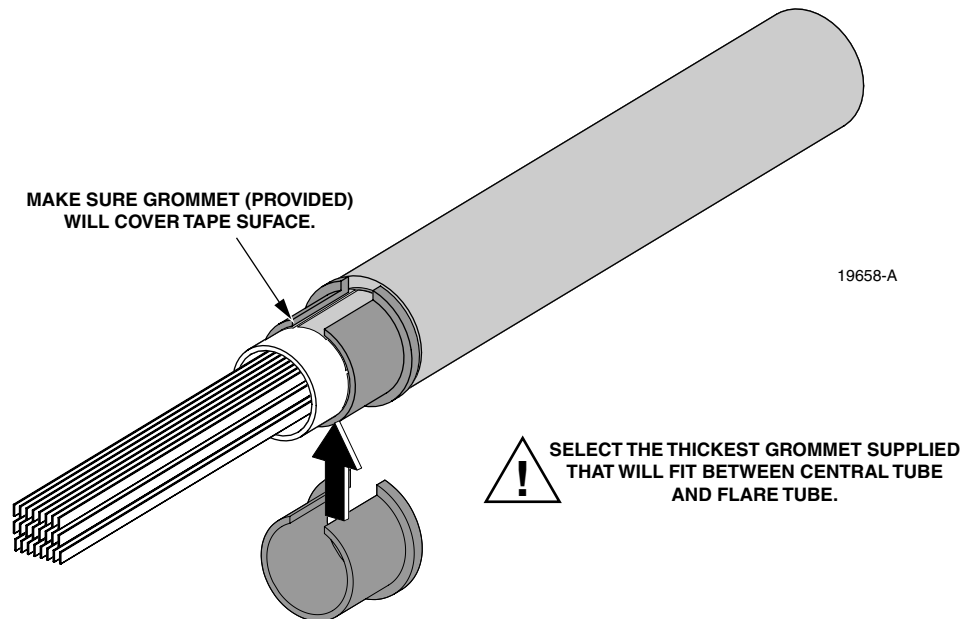

**Figure 13. Install Rubber Grommet**

- Carefully insert central tube into flare tube (provided). Align grommet opening with slot in end of flare tube (Figure 14).

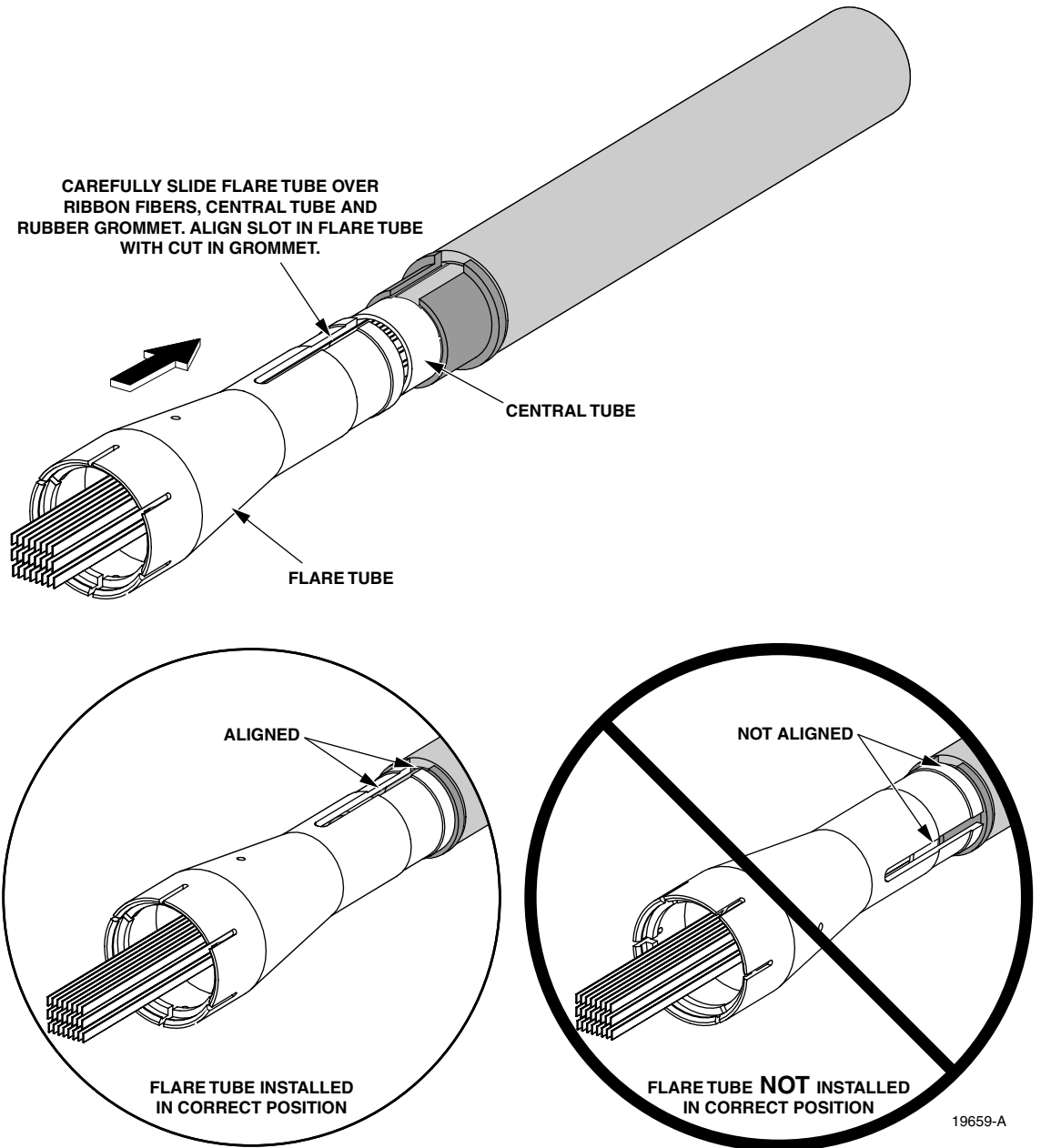

Figure 14. Install Flare Tube

6. Place hose clamp (provided) over flare tube and tighten with screwdriver (Figure 15). Do not over tighten.

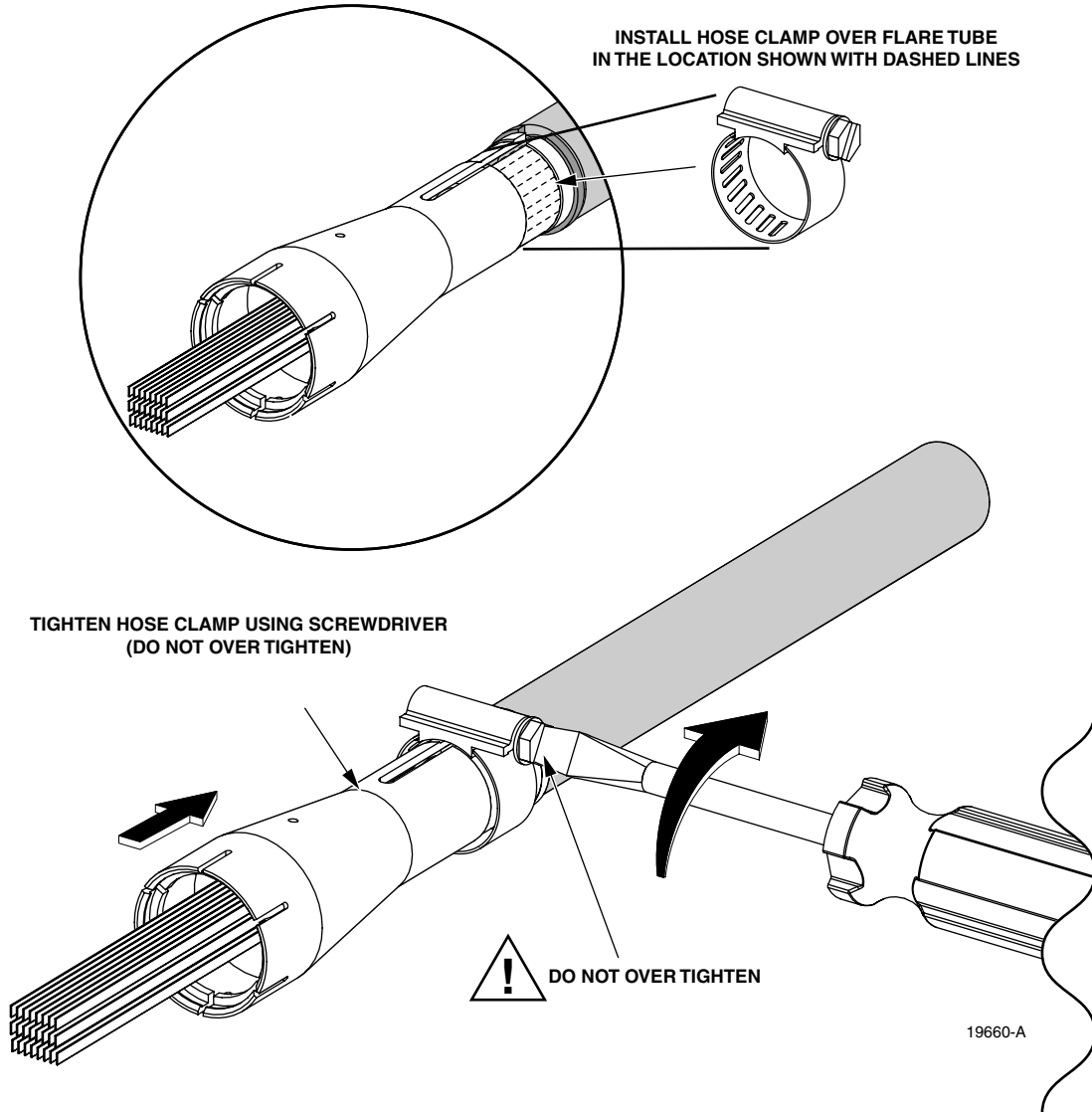
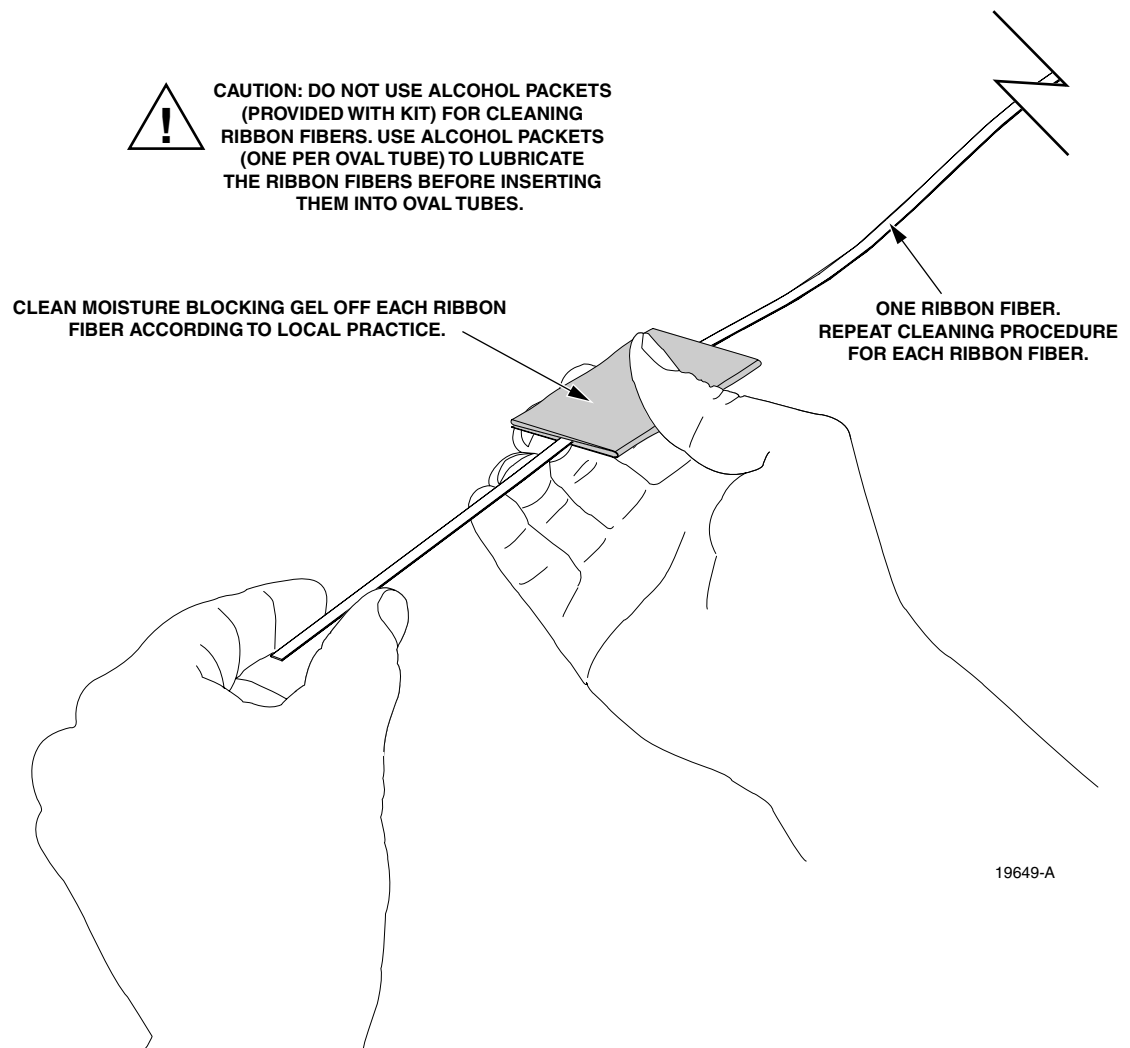

Figure 15. Install Hose Clamp

7. Clean the moisture blocking gel off each ribbon fiber according to local practice.
8. After cleaning ribbon fibers, use alcohol wipes (one per oval tube) to lubricate the top and bottom of the ribbon fibers before inserting ribbon fibers into oval tube (Figure 16).

**⚠ Caution:** *Do not use alcohol packets (provided) for cleaning ribbon fibers, use the alcohol packets to lubricate the ribbon fibers before inserting them into the oval tubes.*



**Figure 16. Clean and Lubricate Ribbon Fibers**

9. Carefully feed ribbon fibers through oval tubes (Figure 17).

**⚠ Caution:** Care must be taken to ensure ribbon fibers are not twisted or bent.

10. Align retainer plate key with flare tube slot and snap into place (Figure 17).

➤ **Note:** Feed up to six, 12-fiber ribbons into each tube at the same time.

➤ **Note:** The oval tubes and retainer plate are shipped pre-assembled as shown.

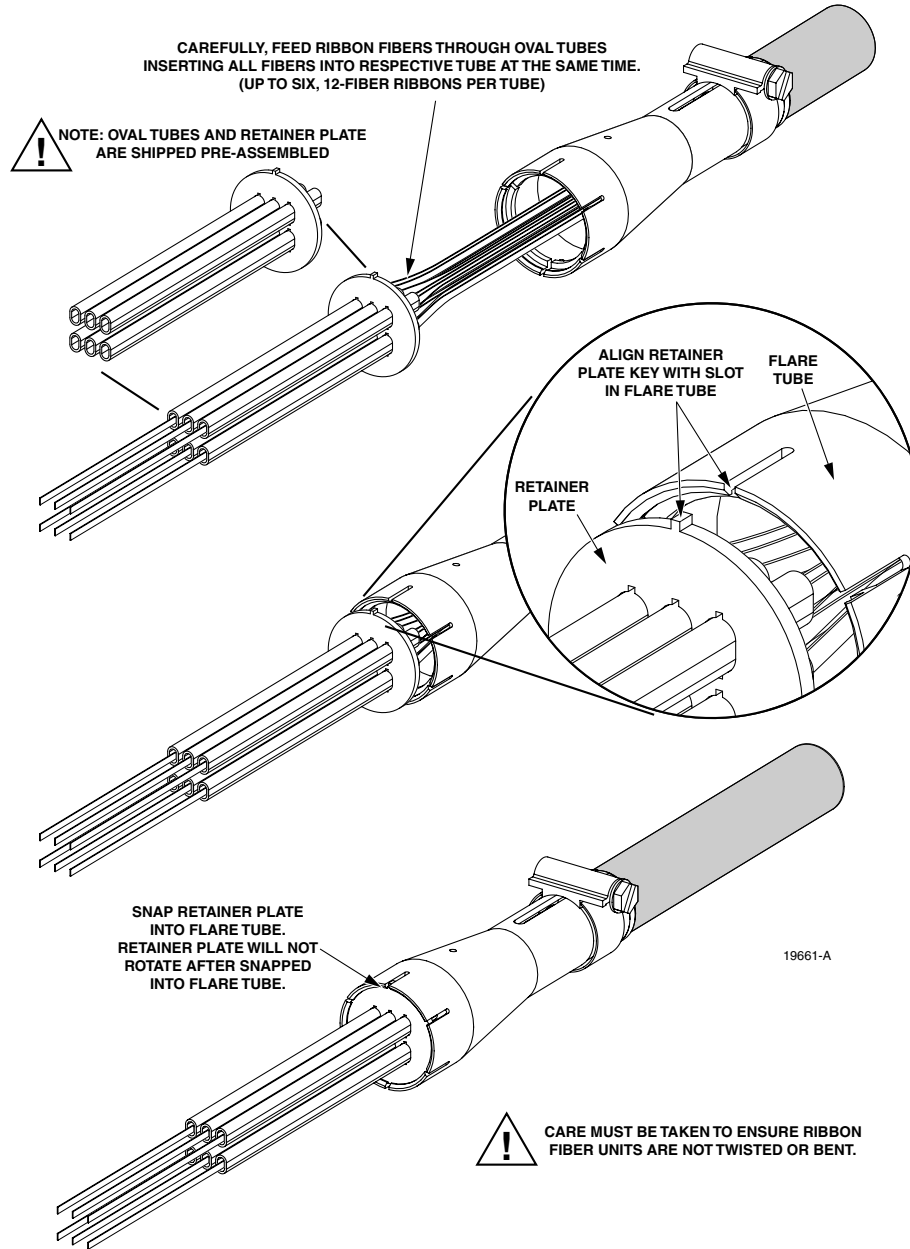

**Figure 17. Feed Ribbon Fibers into Oval Tubes, Snap Retainer Plate into Flare Tube**

11. **(OPTIONAL)** Fill flare tube with water-blocking sealant (Figure 18). Use numbered labels (provided) and mark ends of oval tubes, for reference.

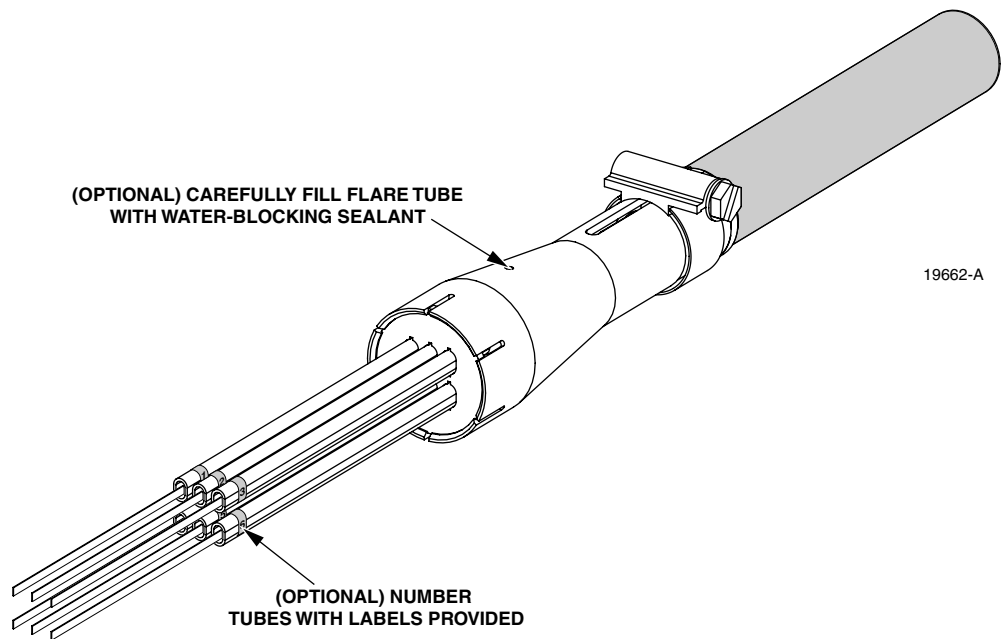

**Figure 18. (Optional) Fill Flare Tube with Water-Blocking Sealant, and Number Tube Ends**

### 3 RIBBON CENTRAL TUBE KIT (BLK-RCT)

Figure 19 shows the catalog scheme for the Ribbon Central Tube Kit. ADC recommends using the Ribbon Central Tube Kit for kits with more than 12-protective tubes. For kits less than 12 protective tubes, use the Central Oval Tube Ribbon Kit (BLK-RCT). See Section 2, "Central Oval Tube Ribbon Kit (BLK-RCT)."

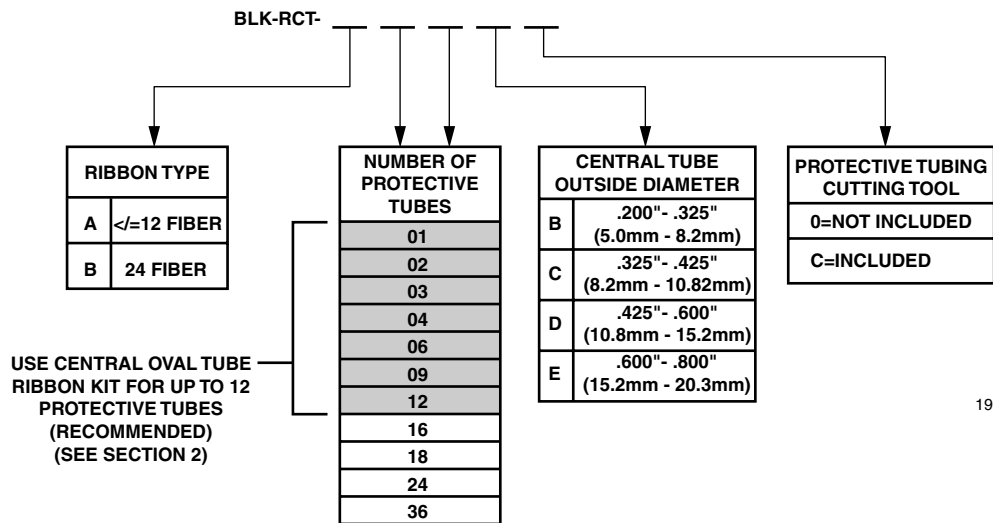
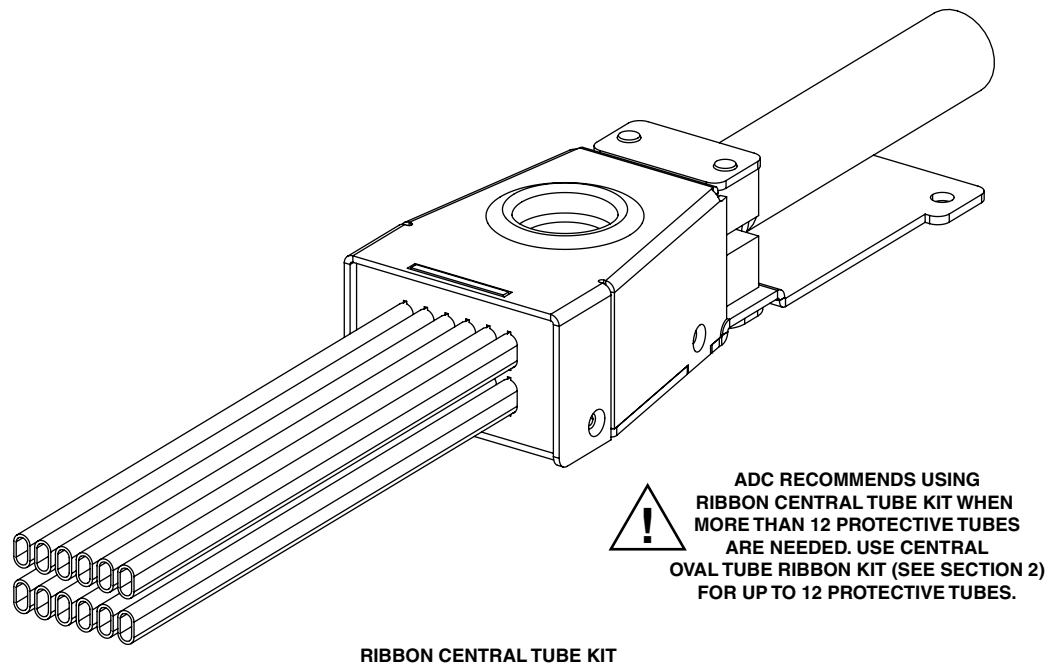

Figure 19. Ribbon Central Tube Kit (BLK-RCT) Catalog Scheme

- Strip outer cable jacket to expose inner central tube. Trim strength members flush with outer cable jacket. Clean residue from outside of central tube to prevent slippage when clamping kit is attached (Figure 20). Note: A maximum of 5 meters (16.4 feet) of bare fiber can be fed through an oval tube.

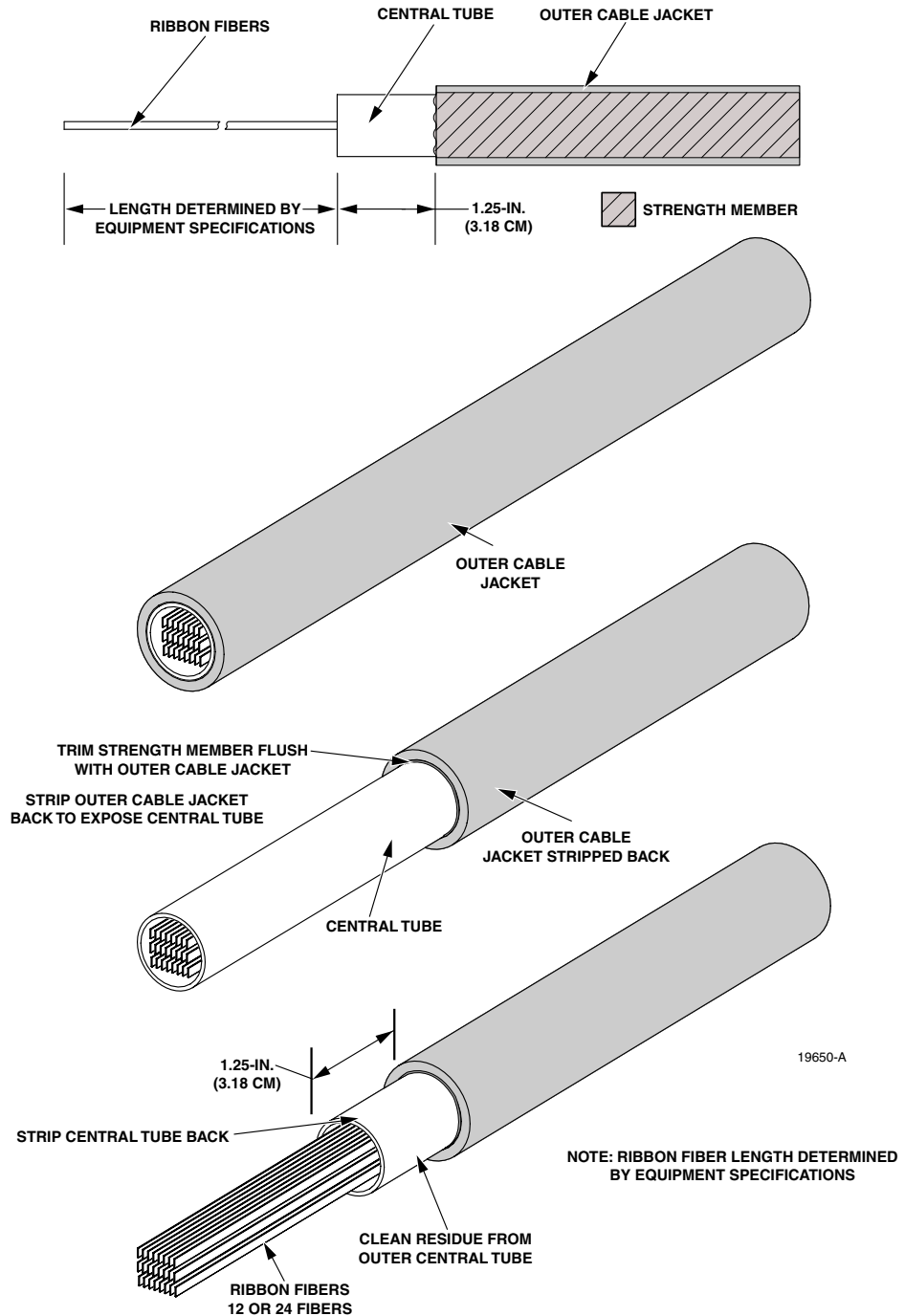



Figure 20. Breakout Ribbon Fibers

2. Clean moisture blocking gel off each ribbon fiber according to local practice (Figure 21).

 **Caution:** Do not use alcohol wipes (provided) for cleaning ribbon fibers.

3. After cleaning ribbon fibers, use alcohol wipes (one per oval tube) to lubricate the top and bottom of the ribbon fibers before inserting ribbon fibers into oval tube.

 **Note:** Top and bottom ribbon fibers should be moist with alcohol when inserting them into oval tubes.

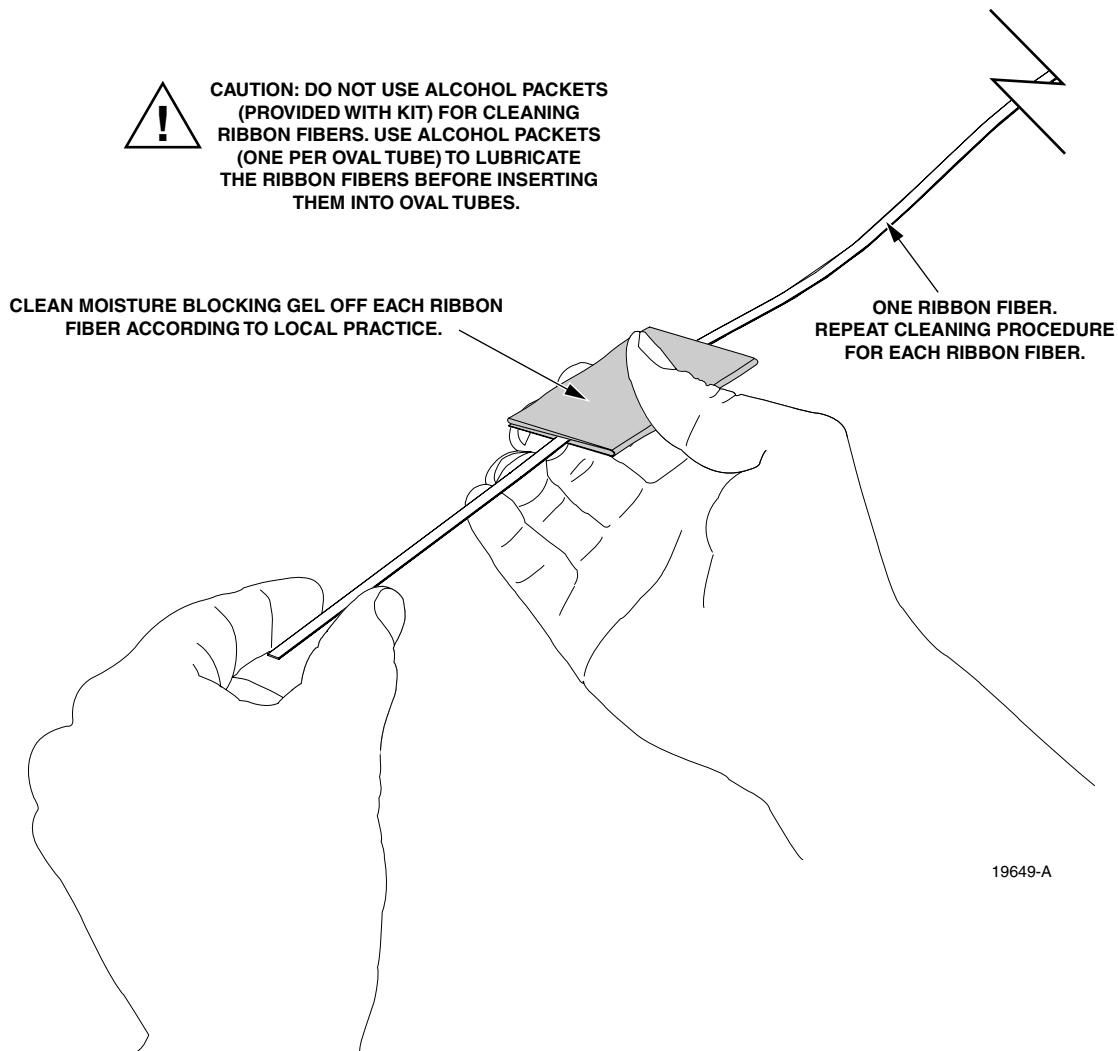

**Figure 21. Clean Moisture Blocking Gel off Ribbon Fibers**

4. Insert ribbon fibers (up to six, 12-fiber ribbons per tube at the same time) into each oval tube (Figure 22).

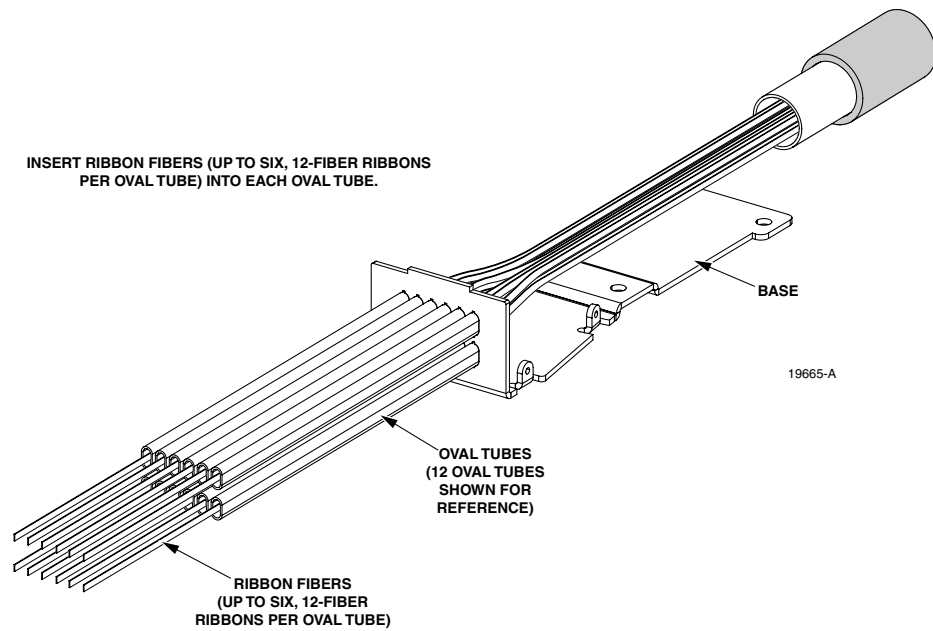

**Figure 22. Insert Ribbon Fibers into Oval Tubes**

5. Continue to carefully guide ribbon fiber into oval tubing while moving base toward the central tube (Figure 23).

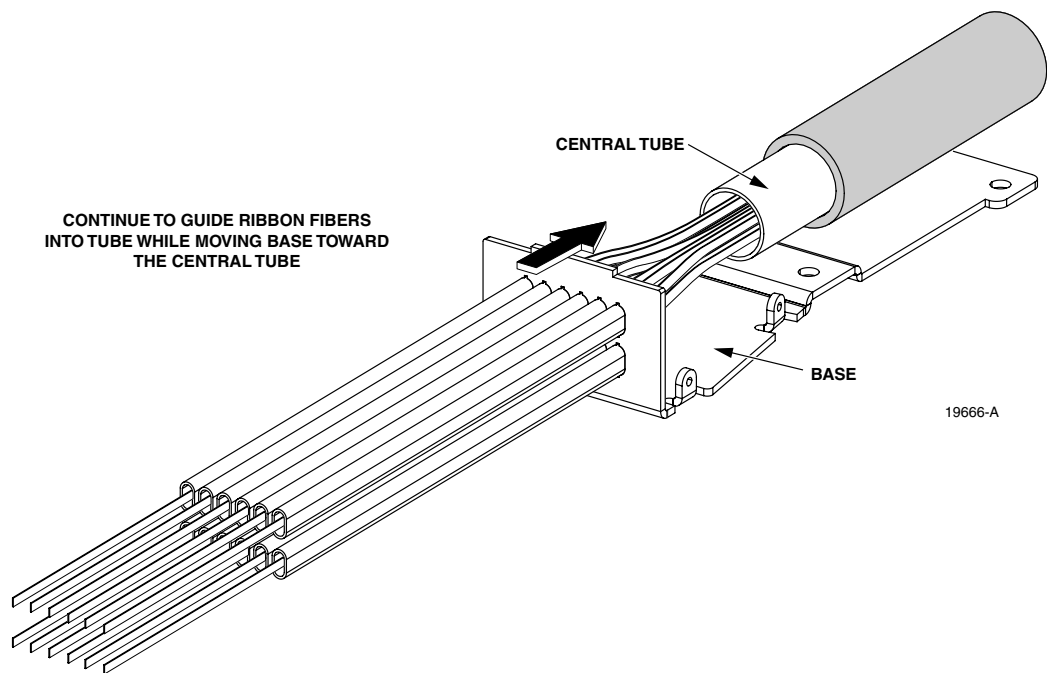

**Figure 23. Guide Base toward Central Tube**

6. Position clamp kit yoke around central tube on base. Make sure central tube protrudes 0.25-inches (0.64 cm) beyond yoke. Insert clamp kit plate and screws (one piece) up through holes in base and yoke. (Figure 24).

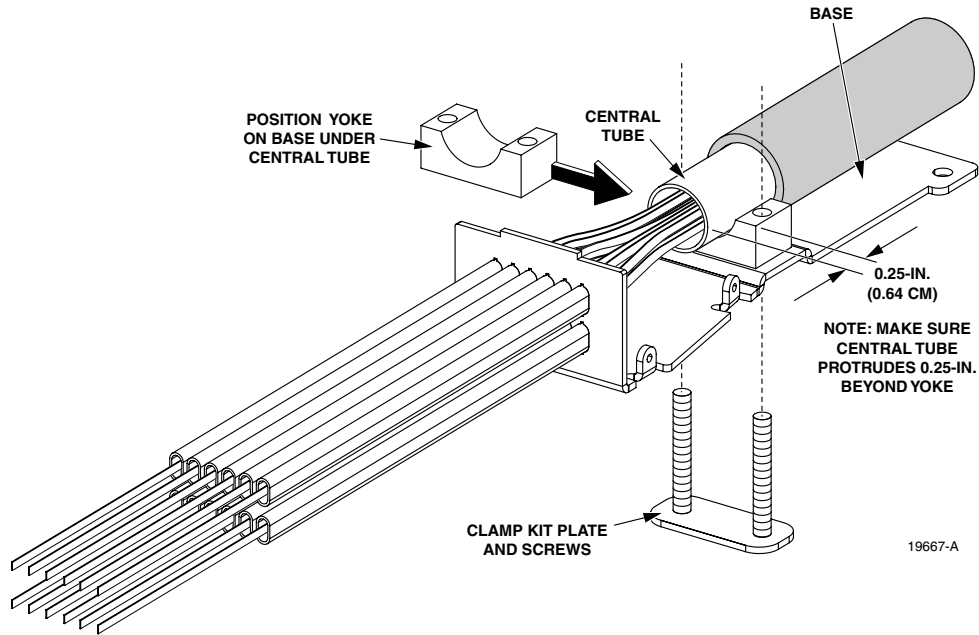

**Figure 24. Install Clamp Kit**

7. Install rubber grommet around central tube, if needed (Figure 25). Note, select thickest rubber grommet that will fit between central tube and yoke.

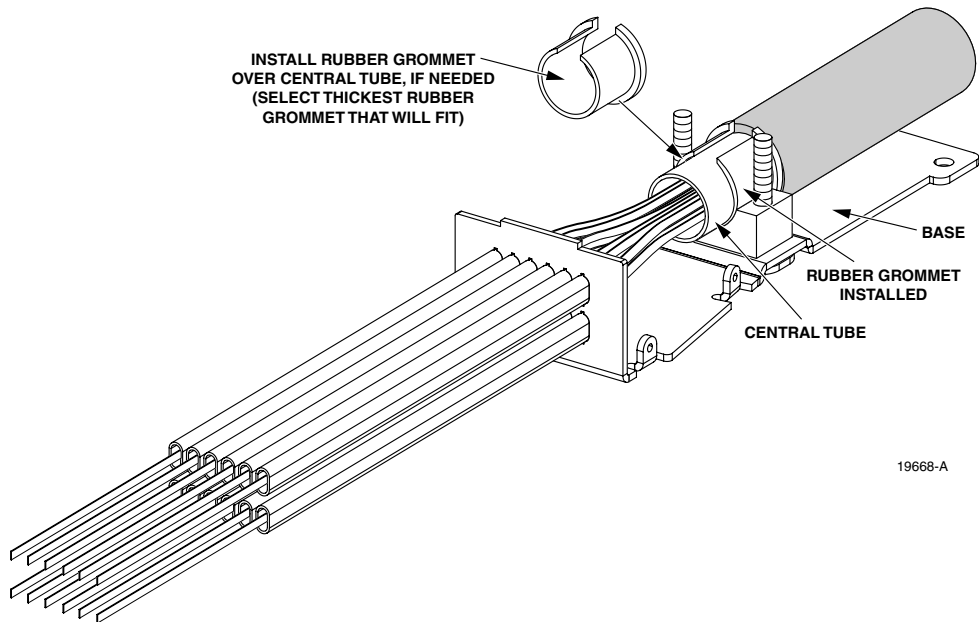

**Figure 25. Install Rubber Grommet (If Required)**

8. Install clamp kit yoke and top plate and tighten down with hex nuts (2). (Figure 26).

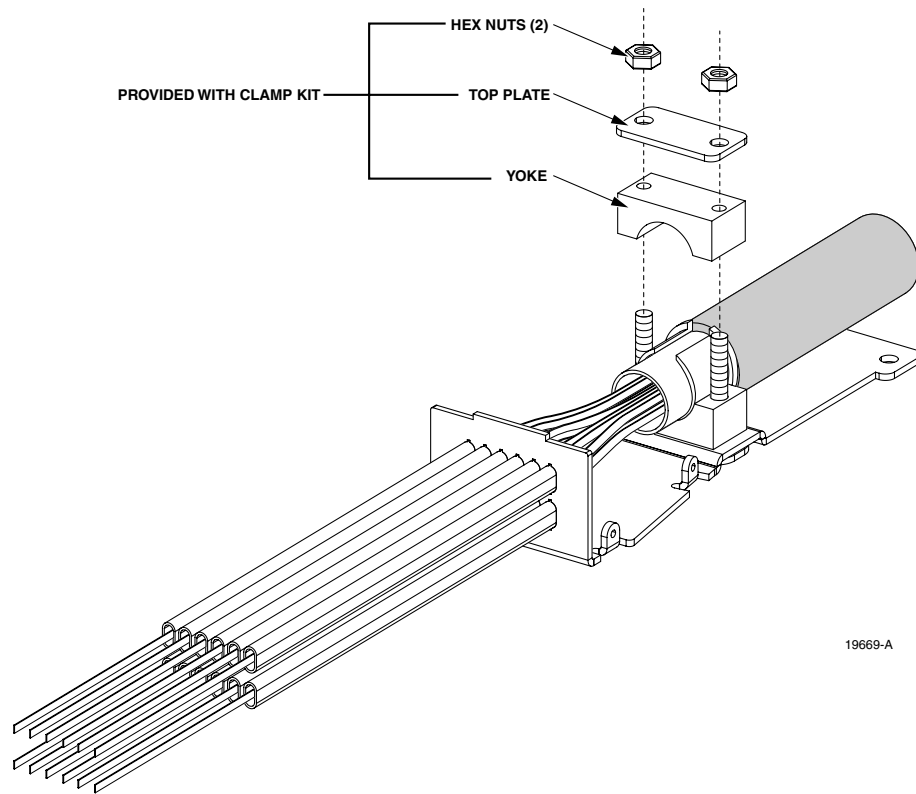

**Figure 26. Install Clamp Kit Yoke and Top Plate**

9. Figure 27 shows the cable clamp kit installed.

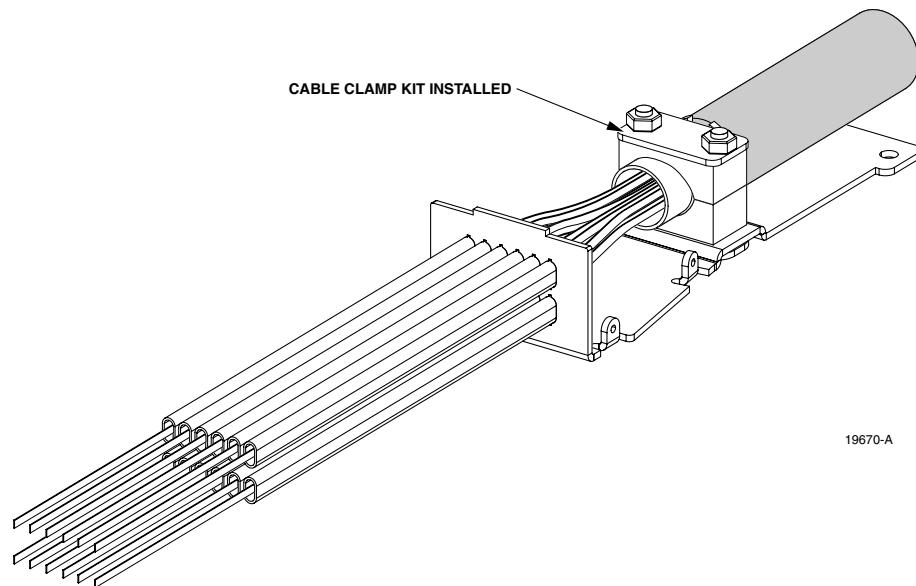

**Figure 27. Cable Clamp Kit Installed**

10. Place cover over ribbon fibers making sure ribbon fibers are not twisted or bent (Figure 28).

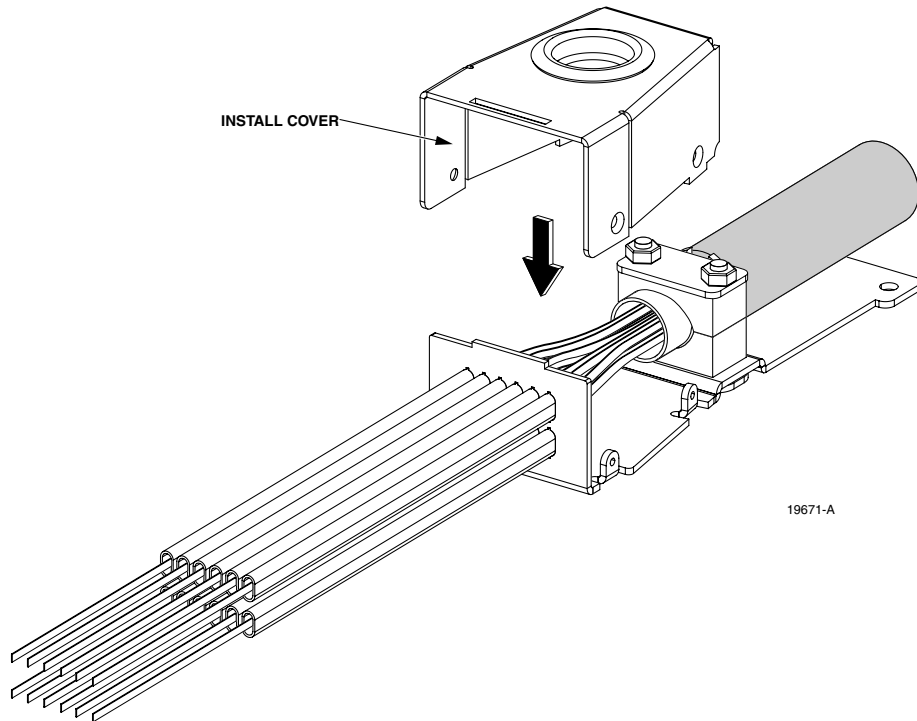

**Figure 28. Install Cover**

11. Secure cover to base using four screws (provided). (Optional) Carefully fill blocking kit with water blocking gel and re-install hole plug (Figure 29). (Optional) Number tubes with labels (provided).

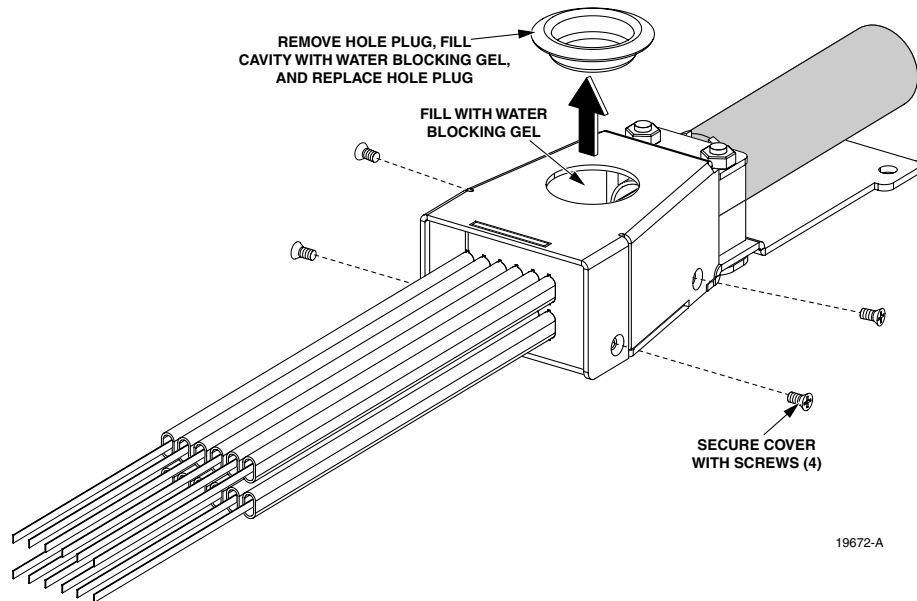

**Figure 29. Install Water Blocking Gel into Hole in Cover**

#### 4 RIBBON IFC CABLE KIT (BLK-RIFC)

Figure 30 shows the catalog scheme for the Ribbon IFC Cable Kit.

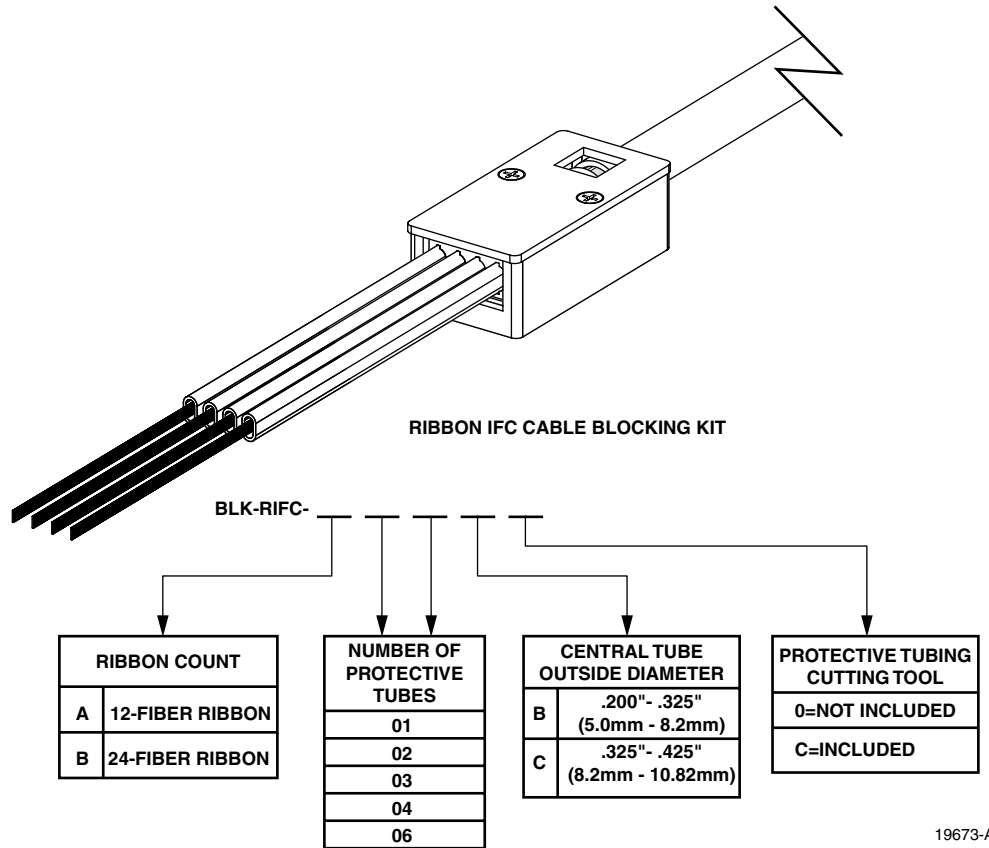
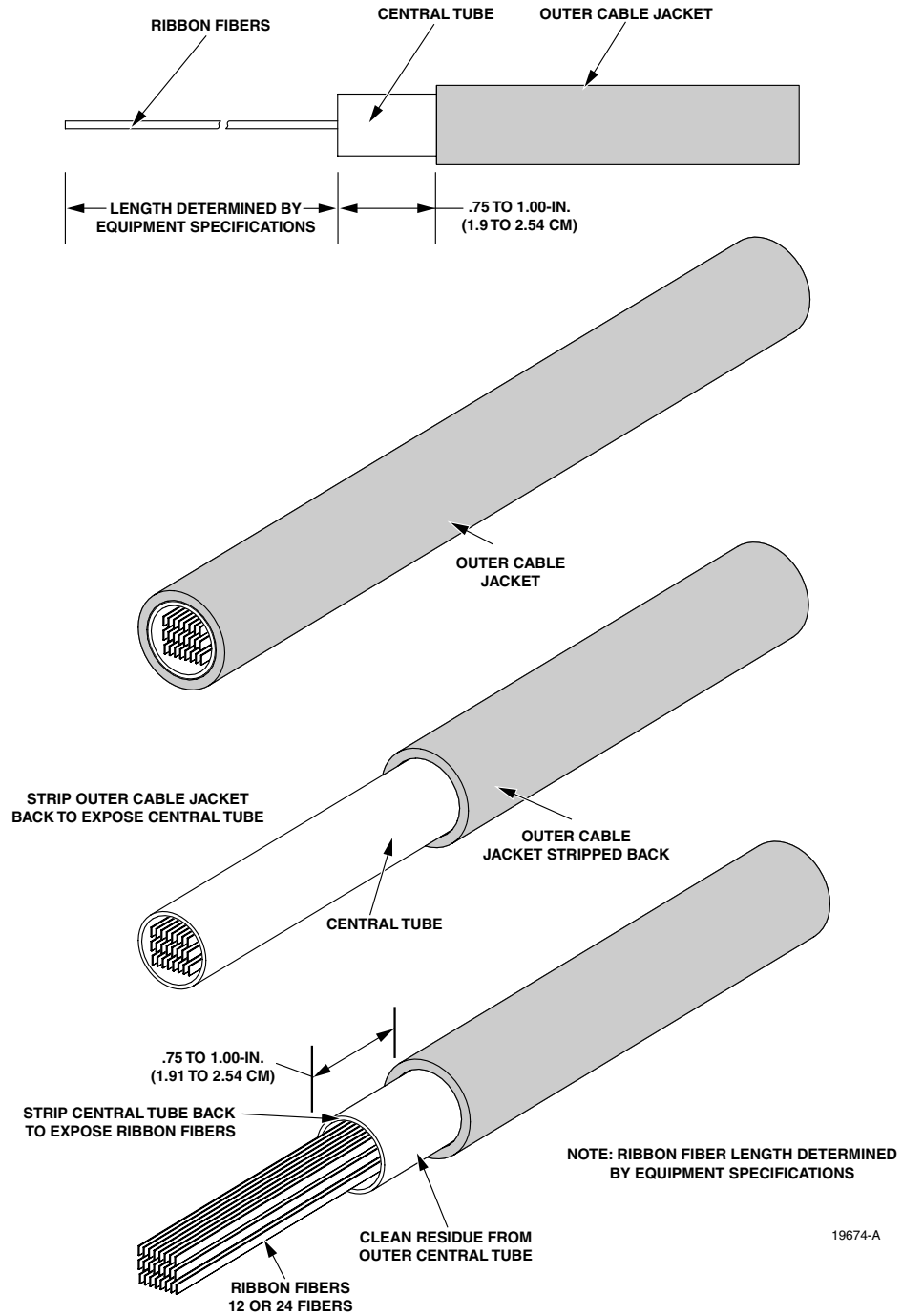

Figure 30. Ribbon IFC Cable Kit Catalog Scheme

1. Strip outer cable jacket to expose inner central tube (Figure 31). Clean residue from outside of central tube to prevent slippage when block is attached.
2. Strip central tube back 0.75 to 1.00-inches (min) to expose bare ribbons. (Ribbon fiber length determined by equipment specifications.) Note: A maximum of 5 meters (16.4 feet) of bare fiber can be fed through an oval tube.



**Figure 31. Strip Outer Jacket and Subunit Jacket**

3. Place black strip tape (provided) around entire end of central tube (Figure 32).

► **Note:** Locate tape so cable ties will cover tape surface when attached to the base.

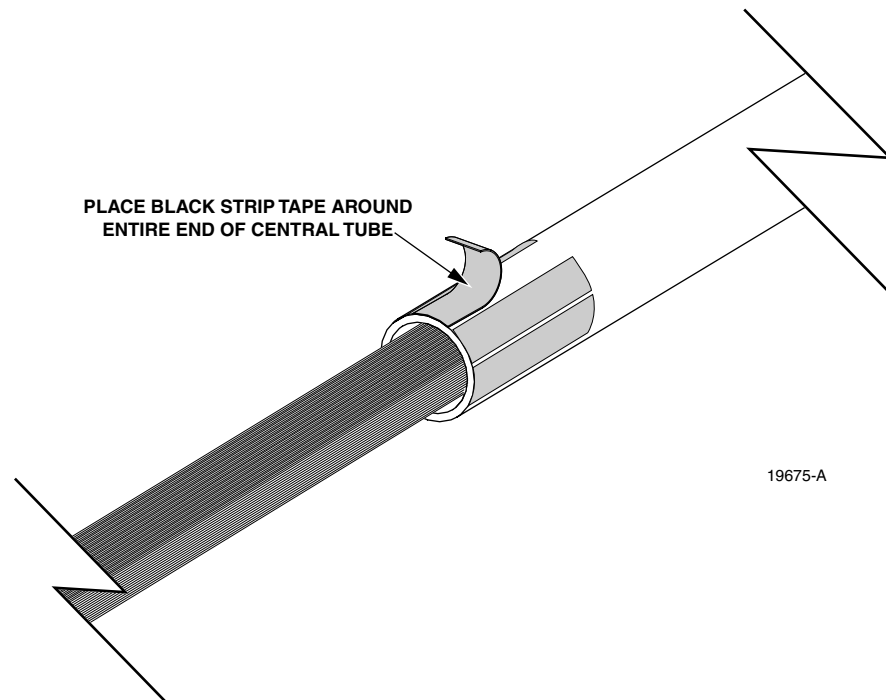
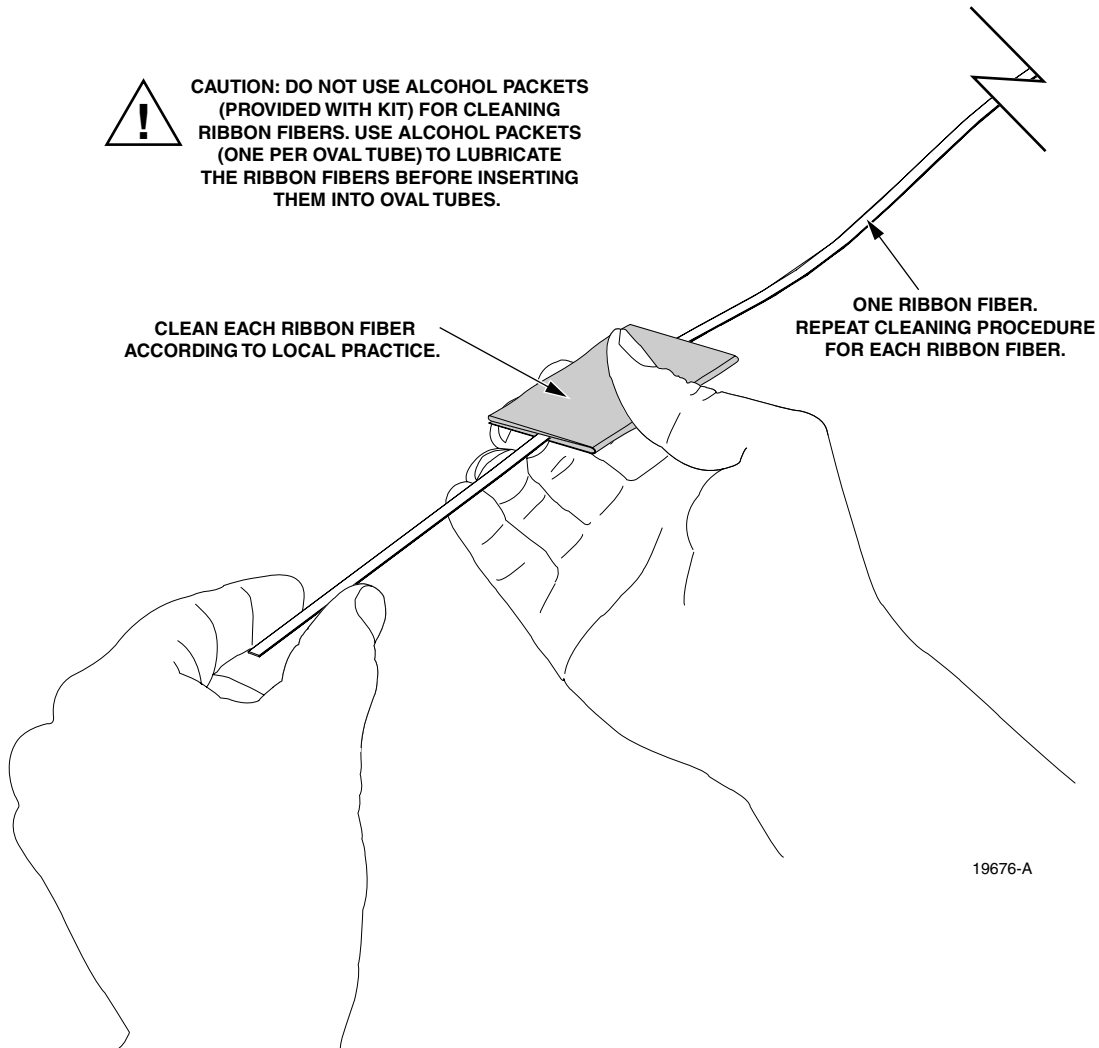

**Figure 32. Place Tape on End of Central Tube**

4. Clean each ribbon fiber according to local practice (Figure 33).

**⚠ Caution:** Do not use alcohol packets (provided) for cleaning ribbon fibers, use the alcohol packets to lubricate the ribbon fibers before inserting them into the oval tubes.

5. After cleaning ribbon fibers, use alcohol wipes (one per oval tube) to lubricate the top and bottom of the ribbon fibers before inserting them into oval tube.



**Figure 33. Clean and Lubricate Ribbon Fibers**

6. Carefully feed ribbon fibers through oval tubes (Figure 34).
- ▶ **Note:** Feed up to six, 12-fiber ribbons into each tube at the same time.
  - ▶ **Note:** The oval tubes and retainer plate are shipped pre-assembled as shown.

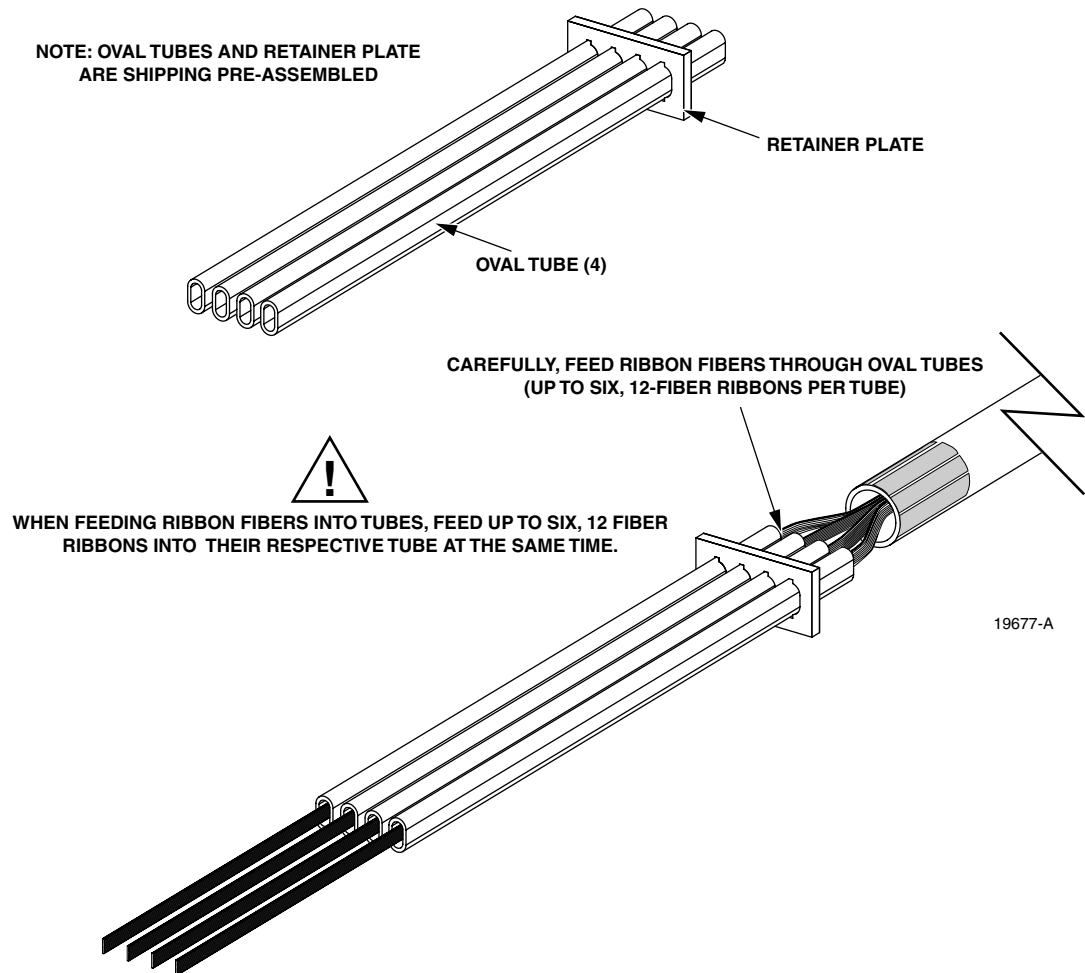
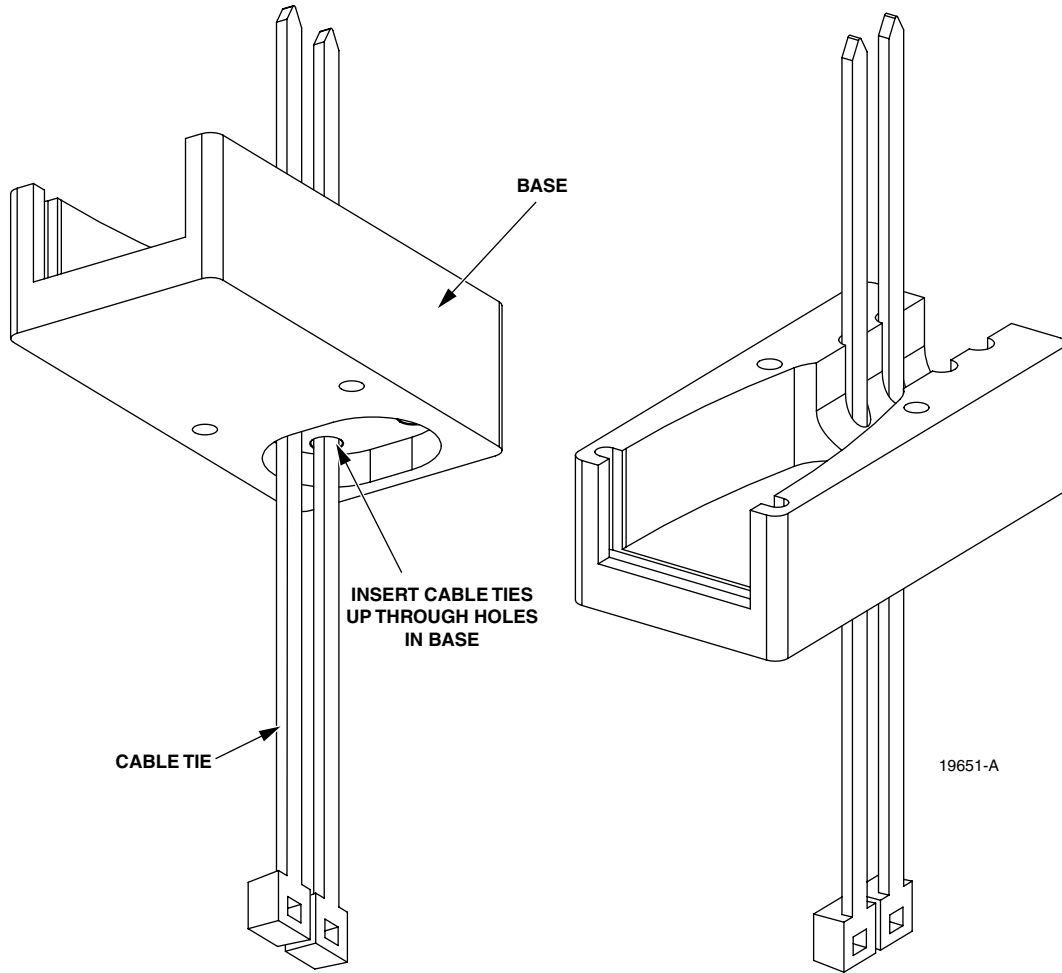

Figure 34. Insert Ribbon Fibers into Oval Tubes

7. Insert cable ties (2) up through holes in bottom of base (Figure 35).



**Figure 35. Insert Cable Tie into Base**

8. Align face plate with face plate pocket in base and place central tube assembly into base (Figure 36). Adjust central tube either forward or backward to the location shown in the lower view.

► **Note:** Central tube assembly includes central tube, ribbon fibers, face plate and oval tubes.

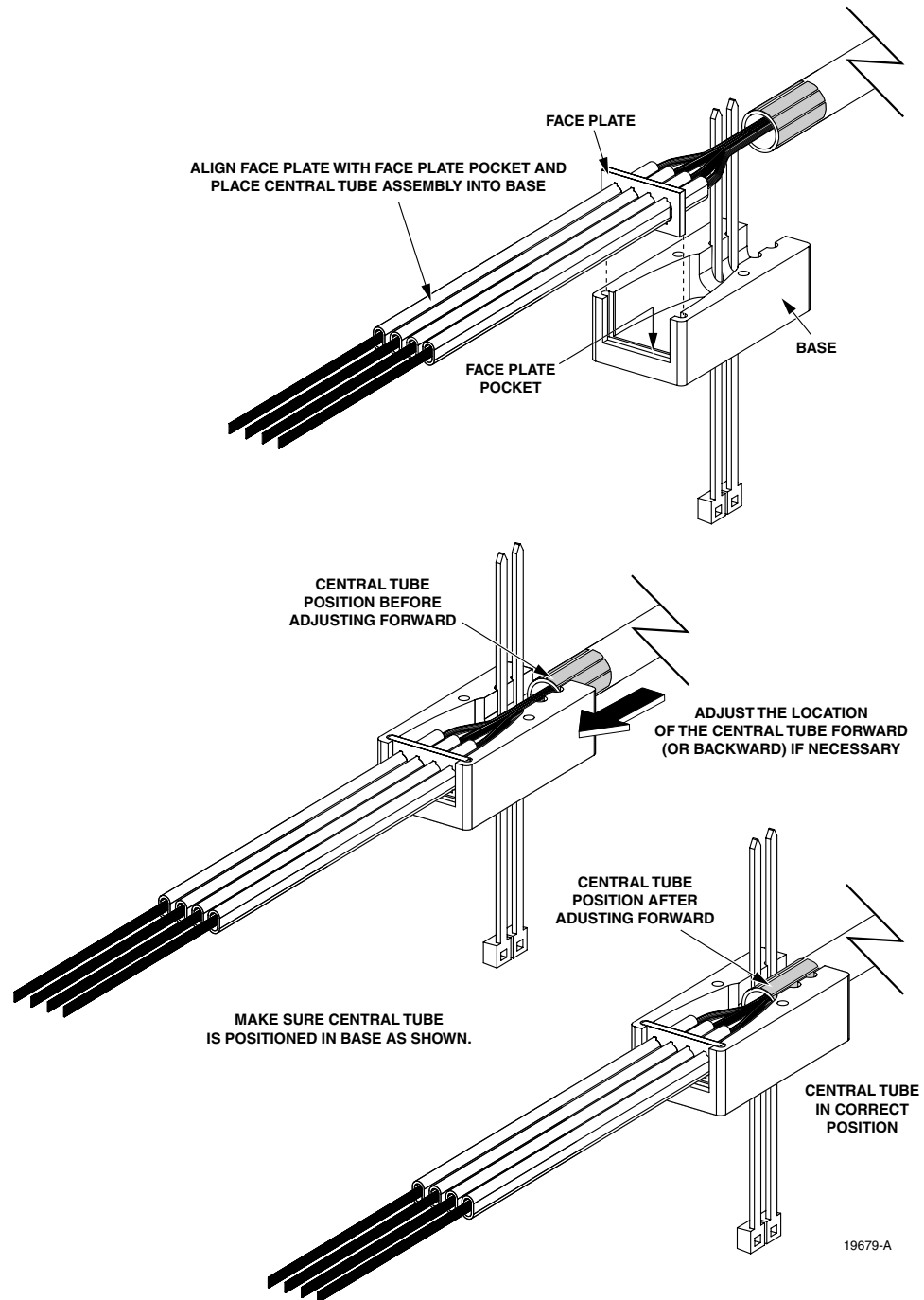

**Figure 36. Place Central Tube Assembly into Fanout Base**

9. Route the cable tie around the central tube and down through the other side of the base (Figure 8). Cinch the cable tie and cut off excess portion.

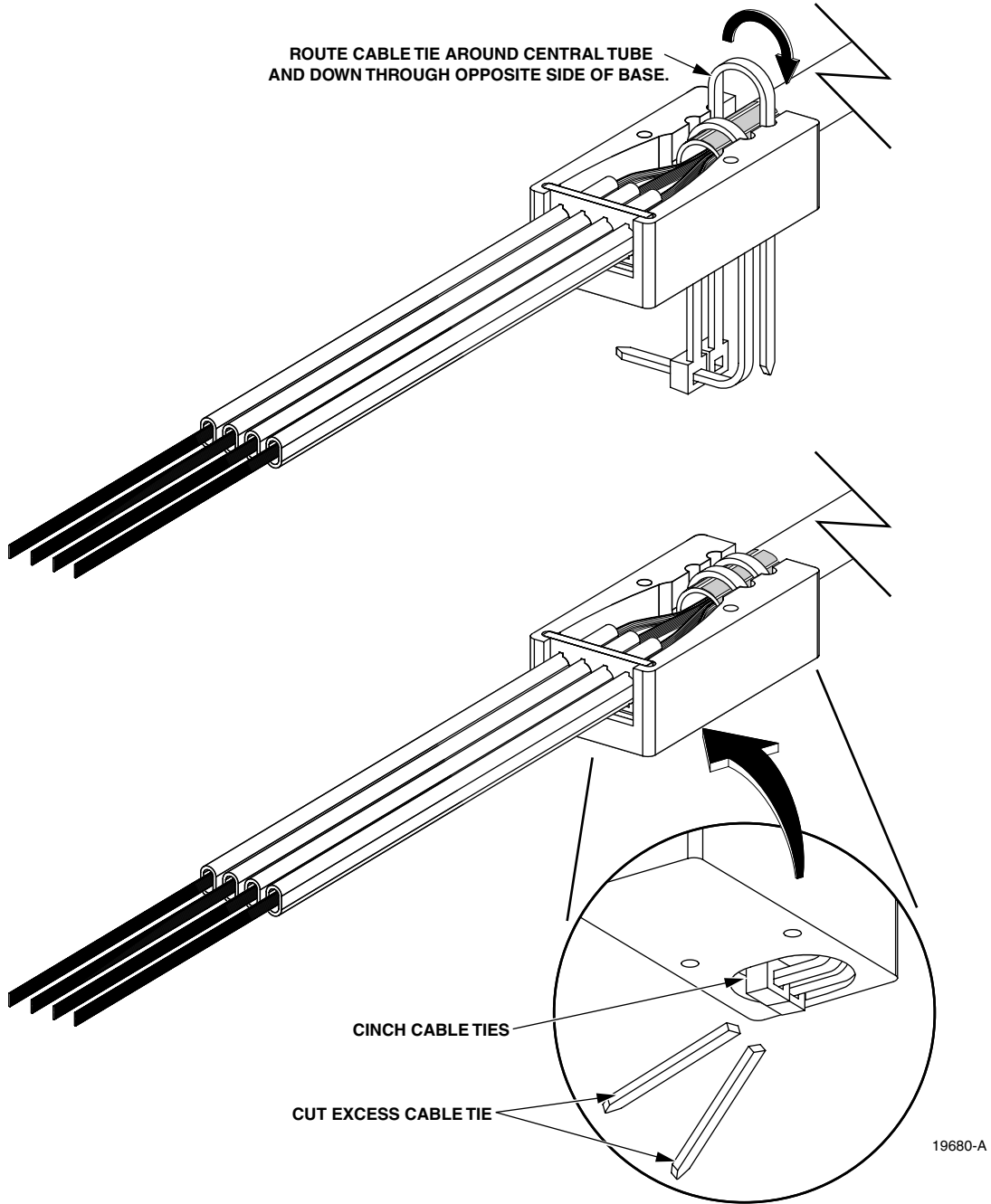

**Figure 8. Install Cable Ties (2)**

10. Secure cover onto base using two screws (Figure 9).

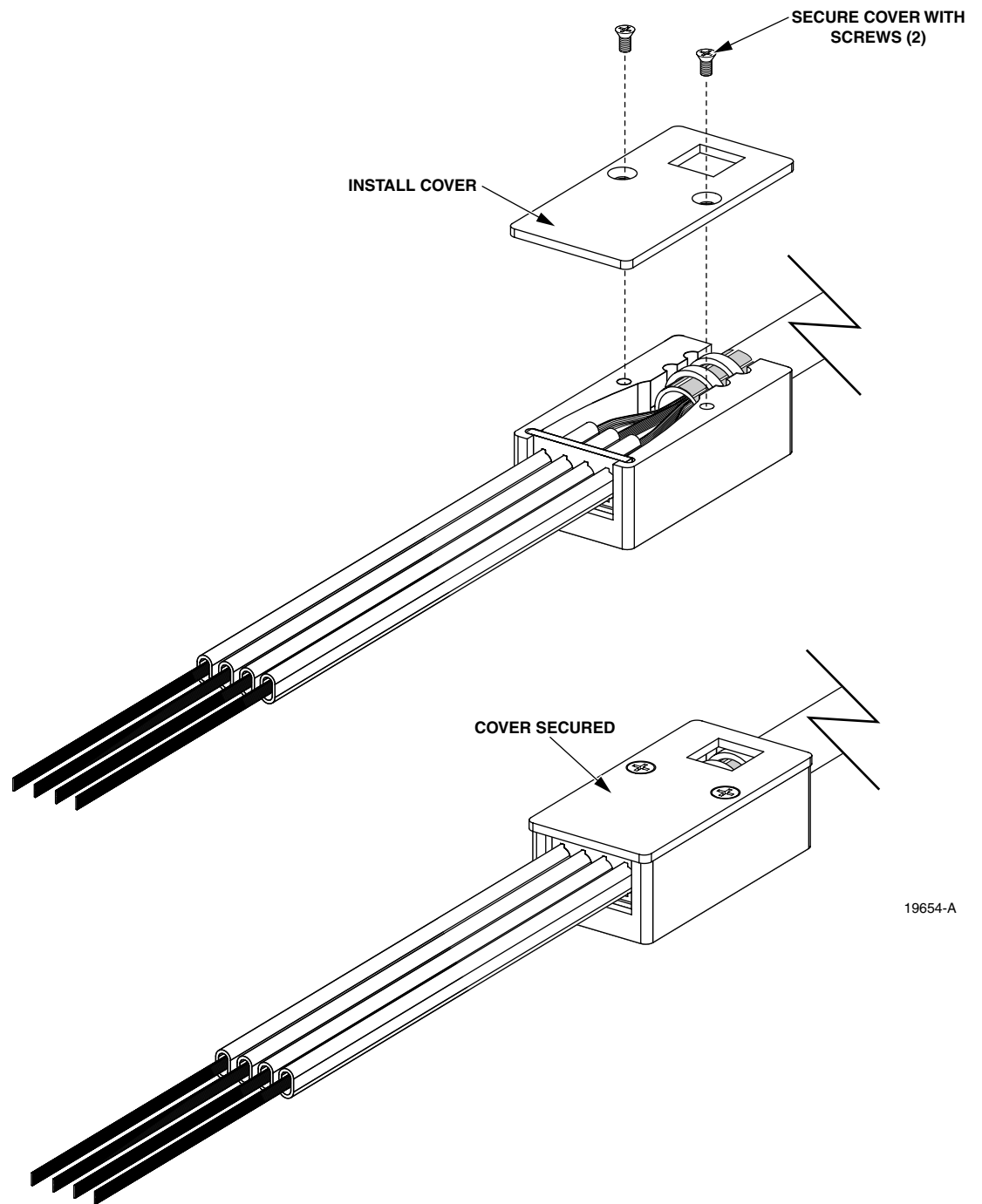

19654-A

Figure 9. Install Top Cover onto Base

## 5 CUSTOMER INFORMATION AND ASSISTANCE

### PHONE: \_\_\_\_\_

#### EUROPE

Sales Administration: +32-2-712-65 00

Technical Assistance: +32-2-712-65 42

#### EUROPEAN TOLL FREE NUMBERS

Germany: 0180 2232923

UK: 0800 960236

Spain: 900 983291

France: 0800 914032

Italy: 0800 782374

#### U.S.A. OR CANADA

Sales: 1-800-366-3891 Extension 73000

Technical Assistance: 1-800-366-3891

└ Connectivity Extension 73475

└ Wireless Extension 73476

#### ASIA/PACIFIC

Sales Administration: +65-6294-9948

Technical Assistance: +65-6393-0739

#### ELSEWHERE

Sales Administration: +1-952-938-8080

Technical Assistance: +1-952-917-3475

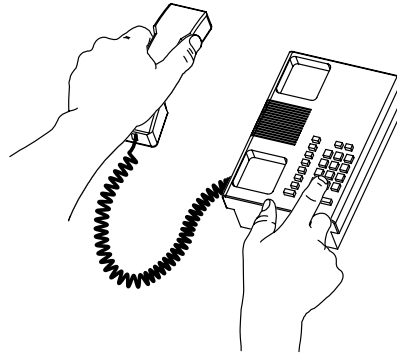

### WRITE: \_\_\_\_\_

ADC TELECOMMUNICATIONS, INC  
PO BOX 1101,  
MINNEAPOLIS, MN 55440-1101, USA

ADC TELECOMMUNICATIONS (S'PORE) PTE. LTD.  
100 BEACH ROAD, #18-01, SHAW TOWERS.  
SINGAPORE 189702.

ADC EUROPEAN CUSTOMER SERVICE, INC  
BELGICASTRAAT 2,  
1930 ZAVENTEM, BELGIUM

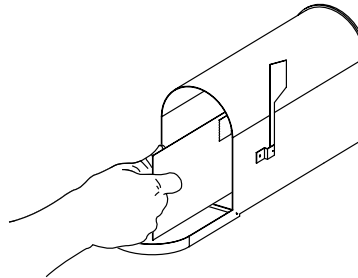

### PRODUCT INFORMATION AND TECHNICAL ASSISTANCE: \_\_\_\_\_

[connectivity\\_tac@adc.com](mailto:connectivity_tac@adc.com)

[wireless\\_tac@adc.com](mailto:wireless_tac@adc.com)

[euro\\_tac@adc.com](mailto:euro_tac@adc.com)

[asiapacific\\_tac@adc.com](mailto:asiapacific_tac@adc.com)

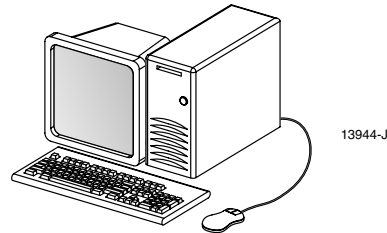

13944-J

Contents herein are current as of the date of publication. ADC reserves the right to change the contents without prior notice. In no event shall ADC be liable for any damages resulting from loss of data, loss of use, or loss of profits and ADC further disclaims any and all liability for indirect, incidental, special, consequential or other similar damages. This disclaimer of liability applies to all products, publications and services during and after the warranty period. This publication may be verified at any time by contacting ADC's Technical Assistance Center.



© 2004, ADC Telecommunications, Inc.  
All Rights Reserved  
Printed in U.S.A.