

REVISIONS			
REV	DESCRIPTION	DATE	APPROVED
01 ₁	REVISED	4/23/97	<i>RAC</i>
B	PER EC 0U20-0694-00	10/3/01	<i>C. Huang</i>

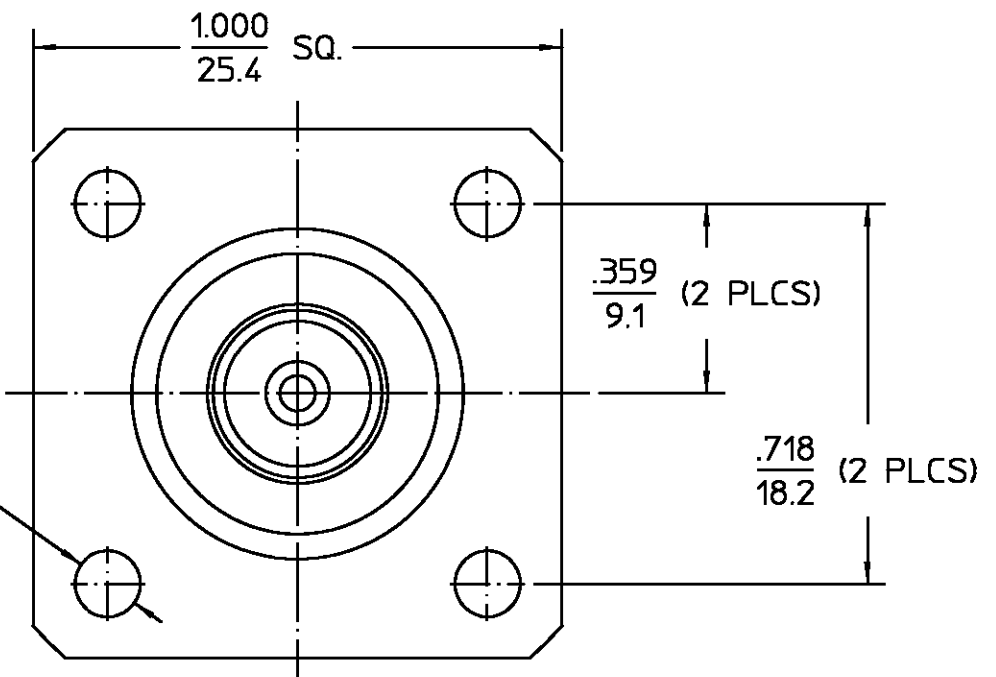
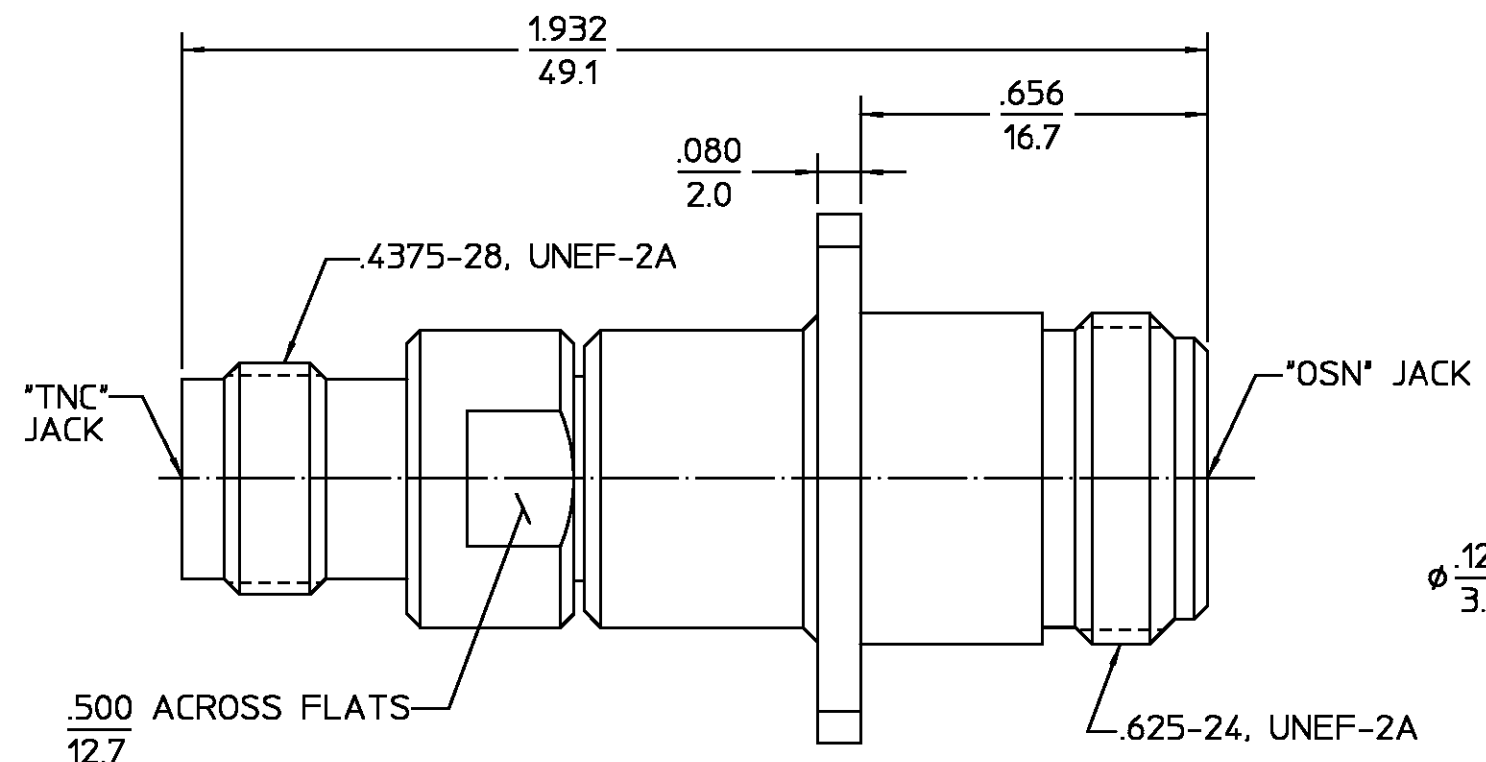

HOUSING	STAINLESS STEEL PER ASTM-A484 AND ASTM-A582, TYPE 303	PASSIVATE PER QQ-P-35
DIELECTRIC	PTFE FLUOROCARBON PER ASTM-D-1457	N/A
CONTACT EXT.	BERYLLIUM COPPER PER ASTM-B-196 OR ASTM-B-197, ALLOY C17300, CONDITION H	GOLD PLATE PER MIL-G-45204
CONTACT EXT. BUSHING & CENTER CONTACT	BRASS PER ASTM-B-16, HALF HARD	GOLD PLATE PER MIL-G-45204

COMPONENT	MATERIAL	FINISH
-----------	----------	--------

UNLESS OTHERWISE SPECIFIED DIMENSIONS ARE IN INCHES FRAC. ± 1/64 DEC. ± .005 ANGLES ± 1°	DRAWN BY SWA	DATE 6/17/85	AMP AMP Incorporated 140 Fourth Avenue Waltham, MA 02451-7599
	CHECKED BY FN	6/18/85	
	APPD BY DN	6/19/85	

These drawings and specifications are the property of M/A COM Interconnect Div. and shall not be reproduced or copied or used in whole or in part as the basis for the manufacture or sale of item(s) without written permission.	USE ASS'Y PROCEDURE	TITLE "TNC" JACK TO "OSN" FLG MOUNT JACK ADAPTER	
	NO. AP. N/A	SIZE B	CODE IDENT NO. 26805
		SCALE 3:1	3180-2302-00
		SHEET 1 OF 1	

NOTES:
1.) CAPTURED CENTER CONTACT

.XXX = in
XX.X = mm (REF)

CUSTOMER DRAWING

AMP PART # 1057843-1
SHEET 1 OF 1 REV B