

Figure 1

1. INTRODUCTION

Flush Floor Outlet Box Kits 1375130-1 (single-gang) and 1375130-2 (double-gang) are designed to house and protect connectors mating round entry cable to undercarpet power cable or communications cable. The outlet box kit also provides a mounting surface for power outlets or communications outlets and outlet cover plates and carpet plates.

NOTE



Dimensions in this instruction sheet are in metric units [with U.S. customary units in brackets]. Figures are not drawn to scale.

Read this instruction sheet thoroughly before starting installation.

To obtain information on AMP NETCONNECT products, call PRODUCT INFORMATION at the number at the bottom of this page or visit the AMP NETCONNECT website at www.ampnetconnect.com.

AMP NETCONNECT logo is a trademark of TE Connectivity.
Thomas & Betts is a trademark.

2. DESCRIPTION

Each outlet box kit consists of a base with foam gasket, leveling ring with foam gasket, base cover, ground terminal and cup washer, disposable concrete cover, and fastening hardware. The single-gang outlet box kit includes an outlet blanking plate with a foam gasket; the double-gang outlet box kit includes two.

The base features ten 1/2- and 3/4-in. round knockouts for round cable entry point. The base cover features one or two outlet opening(s) with a pattern designed to align with outlet opening plates and carpet plates (available separately). The outlet opening pattern is specific to the following Thomas & Betts outlet cover plates and carpet plates:

- Metallic Outlet Cover Plates P-64-[]
- Nonmetallic Outlet Cover Plates P64P-[]
- Single-Gang Metallic Carpet Plate P64-CP
- Single-Gang Nonmetallic Carpet Plates P64P-CP-[]
- Double-Gang Metallic Carpet Plate P64-2G-CP
- Double-Gang Nonmetallic Carpet Plates P64P-2G-CP-[]



Flush Floor Outlet Box/Plate Kit 2111353-1 consists of the single-gang outlet box kit, one Thomas & Betts outlet cover plate, and one carpet plate. Flush Floor Outlet Box/Plate Kit 2111353-2 consists of the double-gang outlet box kit, two Thomas & Betts outlet cover plates and one carpet plate.

3. INSTALLATION

IMPORTANT: It is recommended that a qualified electrician install the flush floor outlet box kit.



DO NOT install power and communications applications together in the same flush floor outlet box. Separate flush floor outlet boxes must be used.



To avoid personal injury, ALWAYS DISCONNECT electrical power before beginning work on any circuit.

3.1. Base

1. Cut two 25.4-mm [1-in.] (approximately) long pieces from the base (12.7 by 609-mm [.50 by 24-in.]) foam gasket. Remove the adhesive backing from the two pieces of foam gasket, and adhere them to the bottom of the base from the outside so that the four threaded holes in the base are covered. See Figure 2.



This will allow the power transition block mounting screws to be installed from inside of the base after the concrete has set around the base.

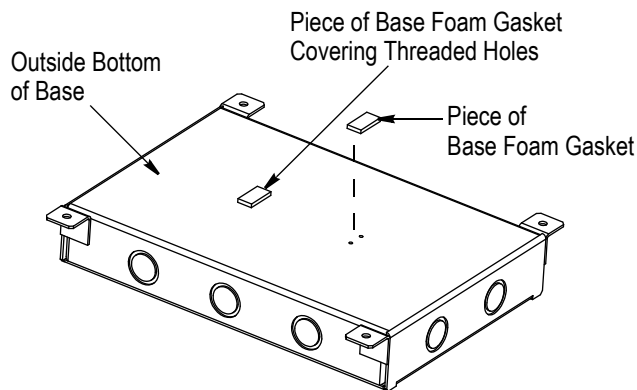

Figure 2

2. Using standard duct tape, cover any cracks or seams where concrete could enter the base from the outside.
3. Position the base at the desired location.
4. Remove the round knockouts and connect conduit for the round entry cable as required for the application and in accordance with electrical codes.

5. Place the concrete cover, with the lip facing up, over the top of the base as shown in Figure 3. Secure the concrete cover to the base using the eight concrete cover (10-32x3/8-in. pan head) screws.

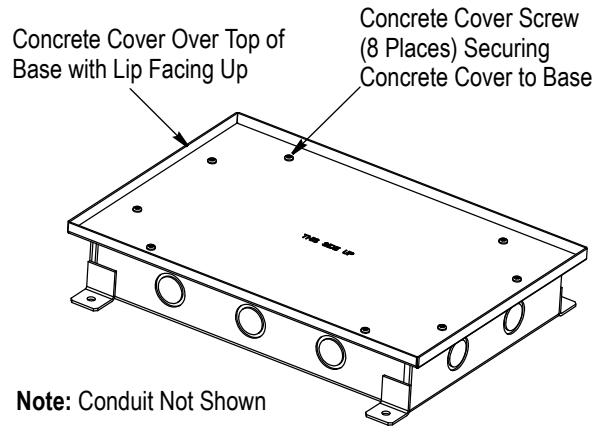

Figure 3

6. Install the four primary leveling (1/4-28x1 1/2-in. pan head) screws in the mounting holes of the base, and turn the screws as required to level the base. The lip of the concrete cover should be flush with the top of the concrete floor. Secure the base to the floor as required for the application and in accordance with electrical codes. See Figure 4.
7. Pour concrete around the base, and allow it to set.

Note: Conduit Not Shown

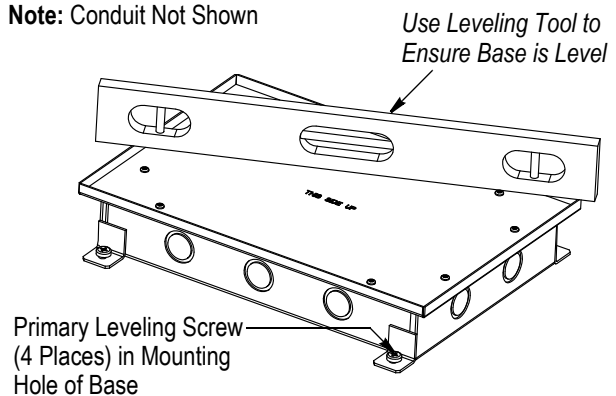

Figure 4

3.2. Leveling Ring

1. Remove the concrete cover screws and concrete cover from the base. Discard the concrete cover.
2. Cut the remaining foam gasket to length as required to cover the top edges of the base completely. Remove the adhesive backing from the base foam gasket, and adhere the foam gasket to the top edges of the base. See Figure 5.

DO NOT discard the remaining foam gasket at this time.

3. Install, but do not tighten, the four secondary leveling (10-32x-1/2-in. pan head) screws in the holes in tabs of the base. Install the ground terminal and cup washer in the (GR) hole of the base. See Figure 5.

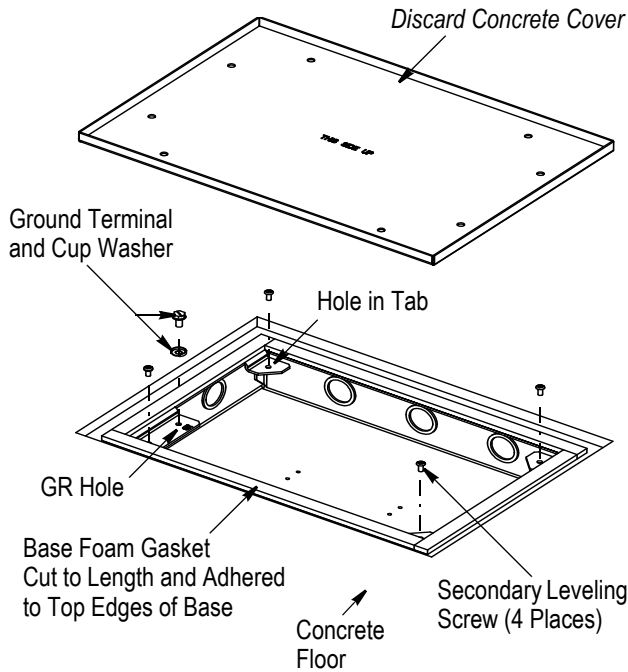

Figure 5

4. Place the leveling ring, with the tabs facing down, on top of the secondary leveling screws. Turn the screws as required to level the leveling ring so that it is approximately 6.35 mm [.25 in.] below the finished concrete floor on all sides. See Figure 6.

5. Secure the leveling ring to the base using the eight leveling ring mounting (10-32x1/2-in. flat head) screws. See Figure 7.

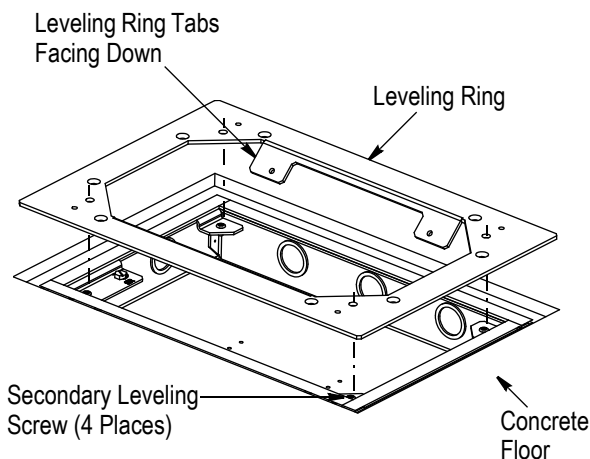

Figure 6

6. Cut the leveling ring (25.4 by 609-mm [1.0 by 24-in.]) foam gasket to length as required that will ensure complete and continuous coverage over the top edges of the leveling ring. Remove the adhesive backing and adhere the foam gasket to the top edges of the leveling ring. See Figure 7. DO NOT discard the remaining of foam gasket at this time.

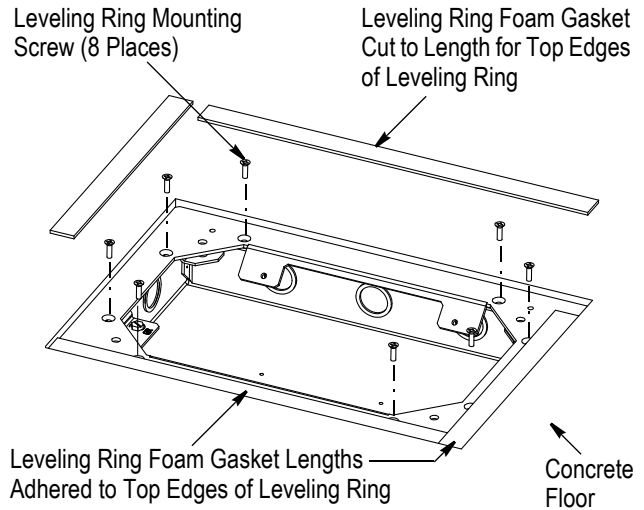
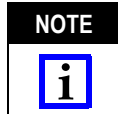

Figure 7

3.3. Cable and Components

A. Power

Install the vinyl floor preparation (for slab-on-grade application), power cable, power transition block(s), and top shield according to the instructions included with the product.



Instruction sheet included with product is:

408-3154 — Vinyl Floor Preparation and Undercarpet Power Cable

408-3176 — Power Transition Block Assembly

408-3150 — Top Shield and Bonding Clips

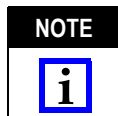

Attach the top shield to a tab of the leveling ring using the stainless steel bonding clips (as shown in Figure 8, Detail A) or using two commercially-available 10-32 screws (as shown in Figure 8, Detail B).

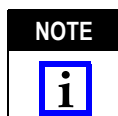

Stainless Steel Bonding Clip 554178-1 is also available separately.

Up to two power transition blocks may be installed in the base.

Ensure proper grounding and bonding is accomplished as required by the application and in accordance with electrical codes.

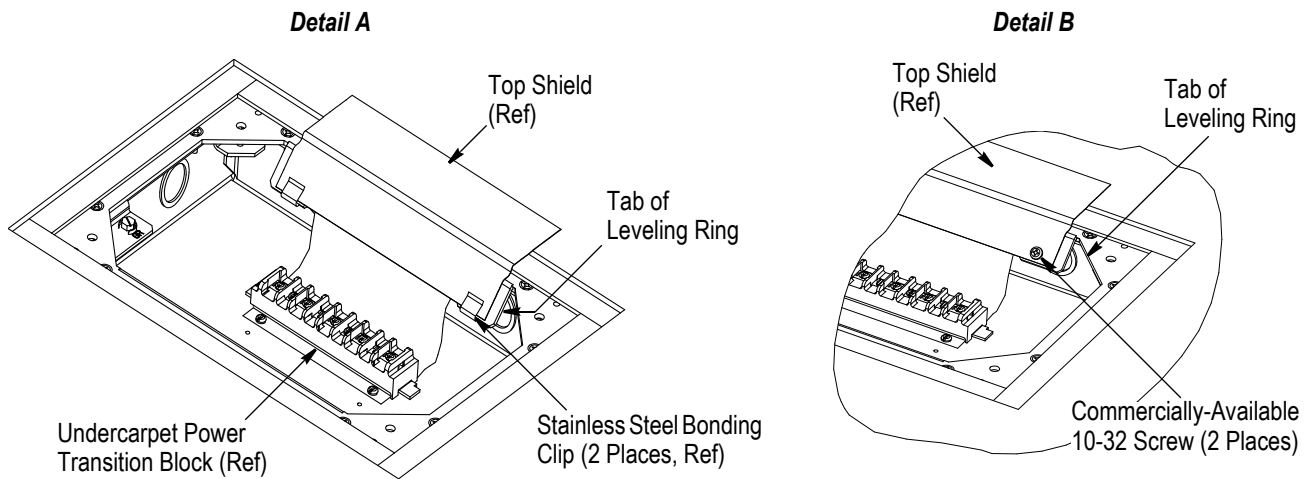
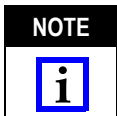

Figure 8

B. Communications

Install the communications transition block(s) and communications cable according to the instructions included with the product. Bonding clips are not required to be used.



- Instruction sheet included with product is:*
- 408-3368 — Category 5e Communications Transition Block
 - 408-10009 — Category 6 Communications Transition Block
 - 408-3194 — Undercarpet Communications Cable

Up to two communications transition blocks may be installed in the base.

If installing a communications outlet(s) in the outlet box, clearance must be maintained between the communications outlets and the communications transition block(s). Ensure clearance is maintained by installing the communications transition block(s) away from the center of the base. See Figure 9.

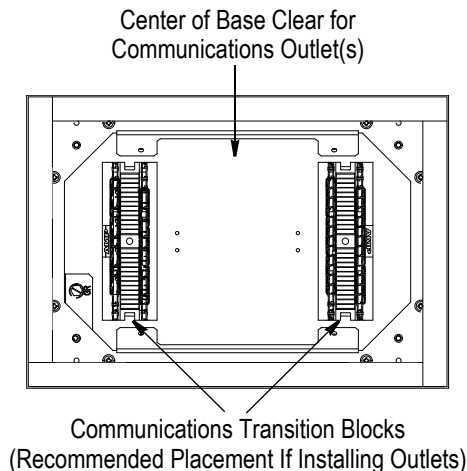
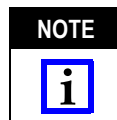

Figure 9

3.4. Blanking Plate, Outlet, and Base Cover



- Outlets are customer-supplied.*
- Duplex and decorator mounting straps are available separately and may be used to provide data and communications ports at the outlet locations.*
- Duplex or decorator receptacles may be used to provide power at the outlet locations. Duplex and decorator receptacles are customer-supplied.*

A. Blanking Plate

If NOT installing an outlet(s) in the outlet box, install a blanking plate over each unused outlet opening of the base cover as follows:

1. Place the blanking plate gasket onto the back of the blanking plate.
2. Place the blanking plate over the outlet opening, and secure the blanking plate to the base cover using the four blanking plate (8-32x3/8-in. flat head) screws. See Figure 10.

Note: Single-Gang Shown

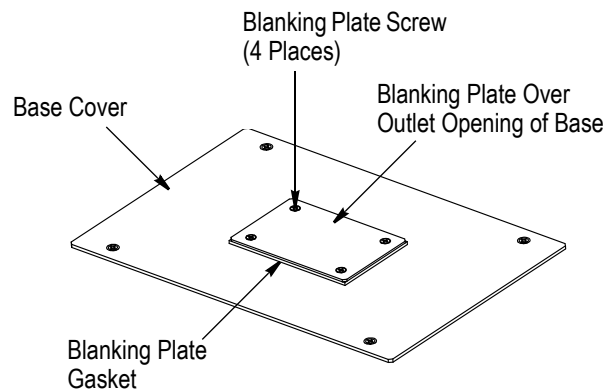

Figure 10

3. Secure the base cover to the leveling ring using the four base cover mounting (10-32x3/8-in. flat head) screws.

B. Outlet Without Carpet Plate

1. Terminate the outlet as required by the application and in accordance with electrical codes, then install the outlet using the hardware included with the outlet onto the base cover.

NOTE *It is recommended installing the outlet onto the base cover prior to securing the base cover to the base.*

2. Place the outlet cover plate foam gasket onto the back of the outlet cover plate, then using the hardware supplied with the outlet cover plate, secure the outlet cover plate to the base cover.

3. Secure the base cover to the leveling ring using the four base cover mounting (10-32x3/8-in. flat head) screws.

C. Outlet With Carpet Plate

1. Secure the base cover to the leveling ring using the four base cover mounting (10-32x3/8-in. flat head) screws.

2. Cut the remaining leveling ring foam gasket to length that will ensure complete and continuous coverage around the outlet opening. Remove the adhesive backing from the foam gasket, and adhere the foam gasket to the base cover as shown in Figure 11.

NOTE *The lengths of foam gaskets must be placed at the edge of the outlet cover plate mounting holes to ensure that the outlet box remains moisture-tight after installing the carpet plate.*

3. Cut four 25.4-mm [1-in.] (approximately) long pieces from the remaining base foam gasket. Remove the adhesive backing from the four pieces of foam gasket, and adhere them to the bottom of the carpet plate so that the four through holes are covered. See Figure 12.

NOTE *This will ensure that the outlet box remains moisture-tight after installing the carpet plate.*

4. Terminate the outlet as required by the application and in accordance with electrical codes, then secure the outlet to the carpet plate using the hardware included with the outlet.

Note: Single-Gang Shown

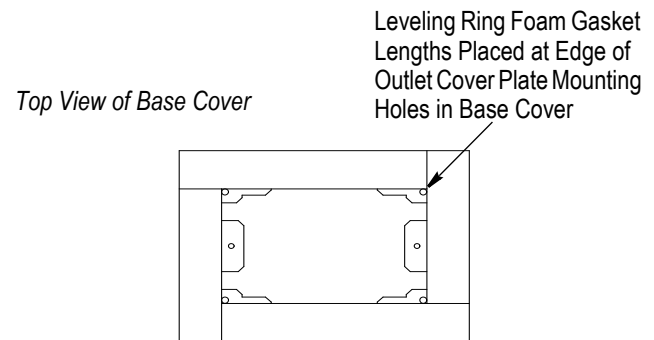
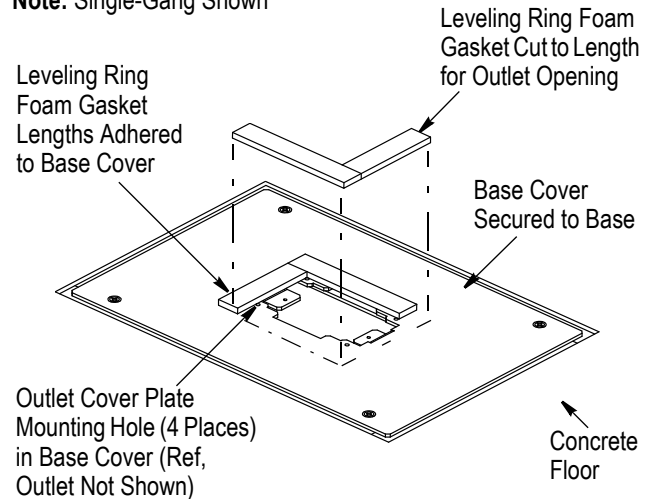

Figure 11

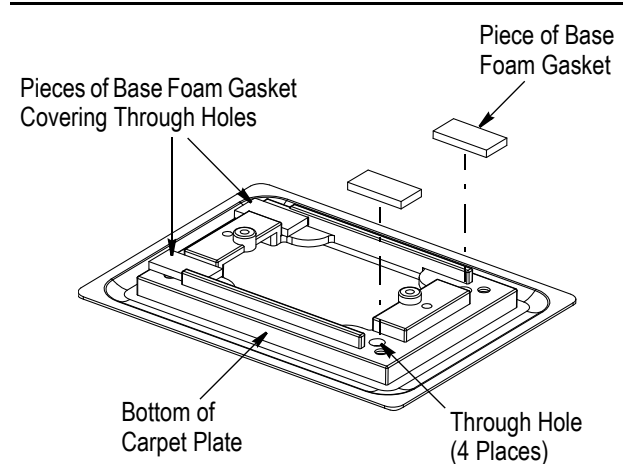

Figure 12

5. Trim the carpet around the outlet opening, and place the carpet over the base cover. The carpet should be positioned between the base foam gasket and the carpet plate. See Figure 13, Detail A.

NOTE



This will ensure a snug, moisture-resistant fit between the carpet and the carpet plate.

6. Place the carpet plate (with outlet), receptacle seating plate, and outlet cover plate (with outlet cover plate foam gasket) over the outlet opening. See Figure 13, Detail A.

7. Using the hardware supplied with the outlet cover plate, secure all of the components to the base cover. See Figure 13, Detail B.

4. REPLACEMENT AND REPAIR

Flush floor base kit components are not repairable. DO NOT use any defective or damaged components.

5. REVISION SUMMARY

Initial release of instruction sheet

Note: Single-Gang Shown

Detail A

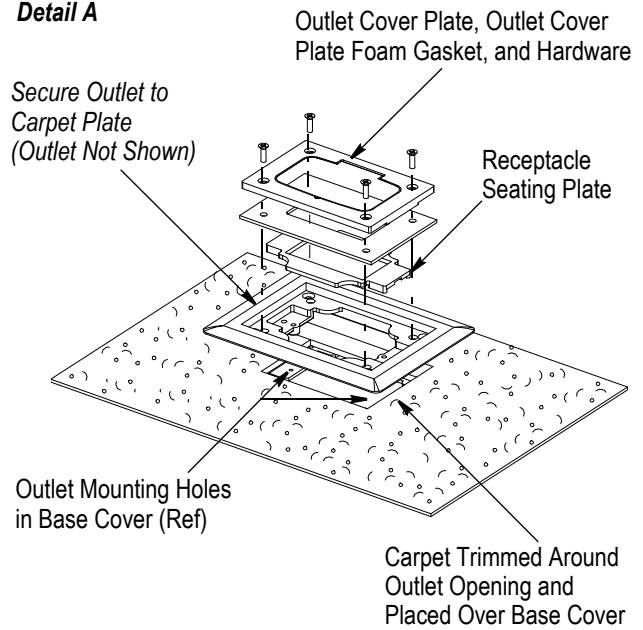

Detail B

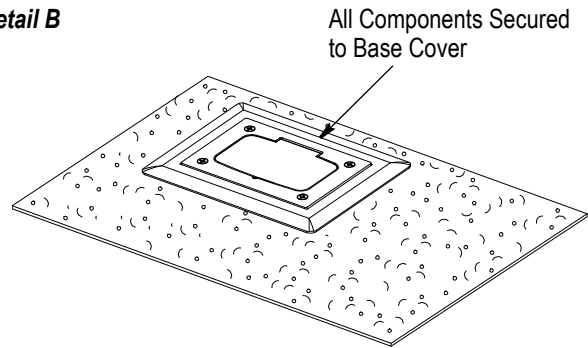

Figure 13