

LOC	DIST	REVISIONS			
HM	00	REV	DATE	BY	APPD
		A	RLSD; ECO-11-00	08APR2011	GG SJ

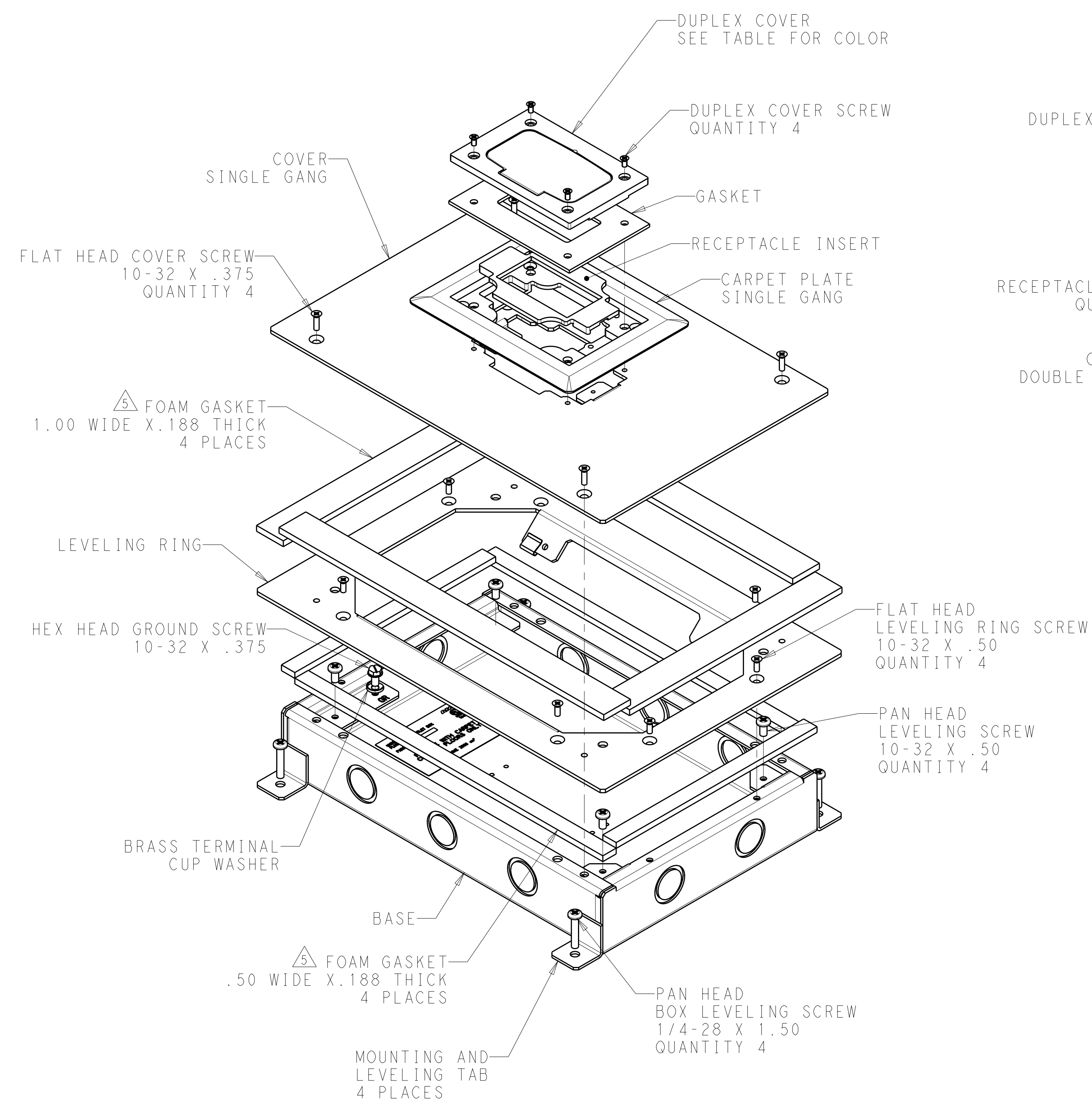

**2111353-1**

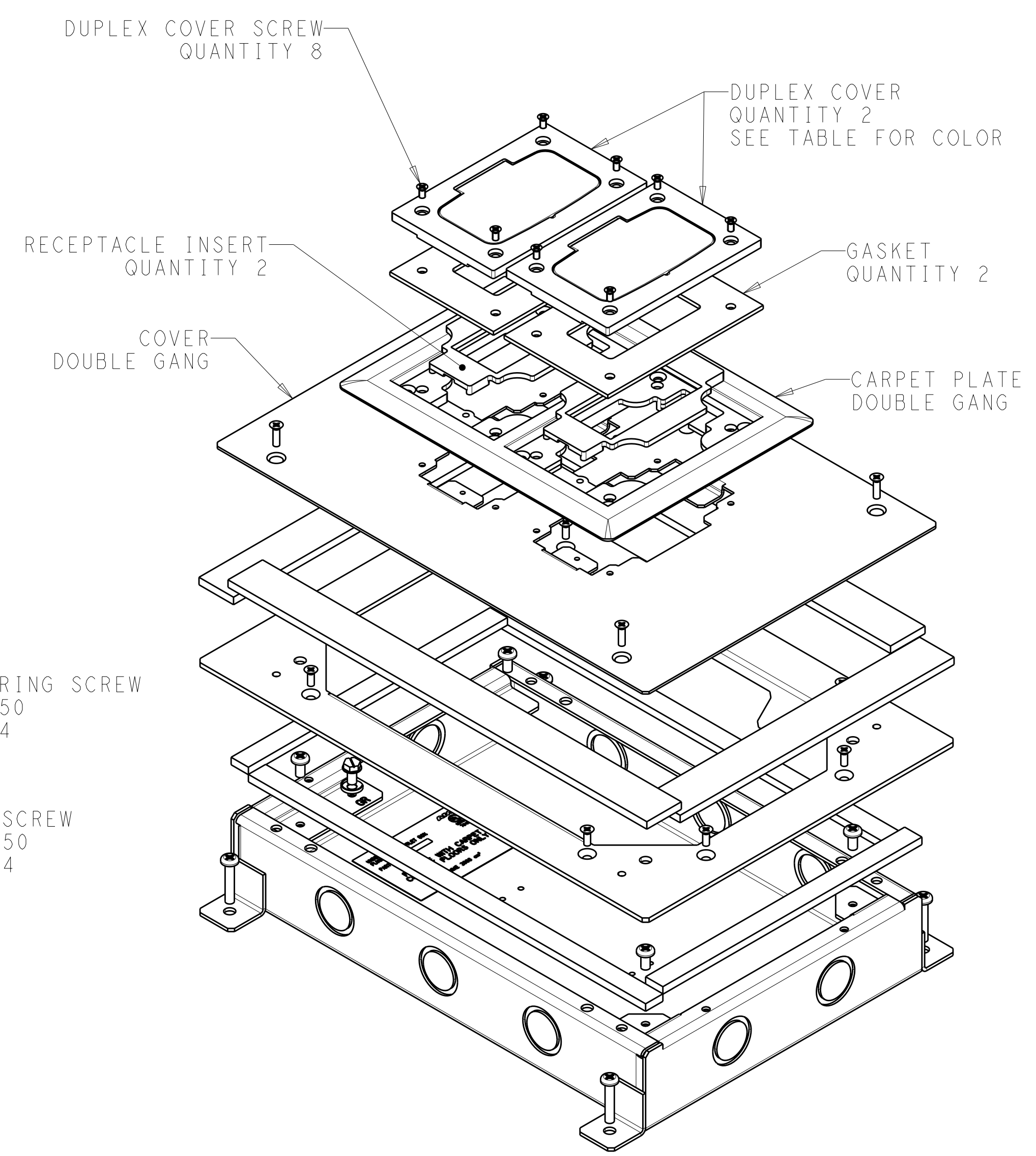

**2111353-2**

- ⚠ MATERIAL: BASE, LEVELING RING, COVERS AND BLANKING PLATE - G90 GALVANIZED STEEL. FOAM GASKETS - POLYURETHANE FOAM. OUTLET COVERS AND CARPET PLATE - POLYCARBONATE, SEE TABLE FOR COLOR.
- ⚠ ALL DIMENSIONS SHOWN ARE NOMINAL.
- 3. KIT SHIPPED NOT ASSEMBLED.
- 4. CONCRETE COVER AND ATTACHING HARDWARE PROVIDED WITH EACH KIT. NOT SHOWN ON DRAWING.
- ⚠ 5. FOAM GASKET CUT TO LENGTH BY CUSTOMER.
- 6. APPLICATION: UNDERCARPET POWER AND COMMUNICATION SYSTEM:
  - CONCRETE BOX FOR USE WHERE TRANSITION BETWEEN ROUND CONDUCTORS AND FLAT CONDUCTORS IS NECESSARY.
  - INCLUDES THOMAS AND BETTS STEEL CITY METALLIC OR NON METALLIC 640/840 SERIES COVER PLATES.
  - USE WITH CUSTOMER SUPPLIED DUPLEX RECEPTACLE OR MOUNTING STRAP.
  - REFER TO I.S. 408-10425 FOR INSTALLATION INSTRUCTIONS.
- 7. POWER AND COMMUNICATIONS SHALL NOT BE INSTALLED IN THE SAME BOX. USE SEPARATE BOXES FOR POWER AND COMMUNICATIONS.
- 8. FOR USE WITH CARPET COVERED FLOORS ONLY.

GRAY	DOUBLE GANG	2111353-2
GRAY	SINGLE GANG	2111353-1
COVER COLOR	DESCRIPTION	PART NUMBER

DIMENSIONS: mm [INCHES] TOLERANCES UNLESS OTHERWISE SPECIFIED: 9 PLC ± .1 3 PLC ± .05 4 PLC ± .02 ANGLES ± .5° MATERIAL: - FINISH: -		DWN: S. GARRETT 06DEC2010 CHK: S. JONES 06DEC2010 APVD: S. JONES 06DEC2010 PRODUCT SPEC: 408-10425 APPLICATION SPEC: - WEIGHT: - CUSTOMER DRAWING	Tyco Electronics Corporation Harrisburg, PA 17105-3608 NAME: ASSEMBLY, FLUSH FLOOR OUTLET BOX, WITH COVER AND CARPET RING SIZE: A100779 CAGE CODE: C=2111353 SCALE: 1:2 SHEET: 1 OF 2 REV: A
---	--	---	---

LOC	DIST	REV	DATE	DWN	APVD
HM	00				
		SEE SHEET 1			

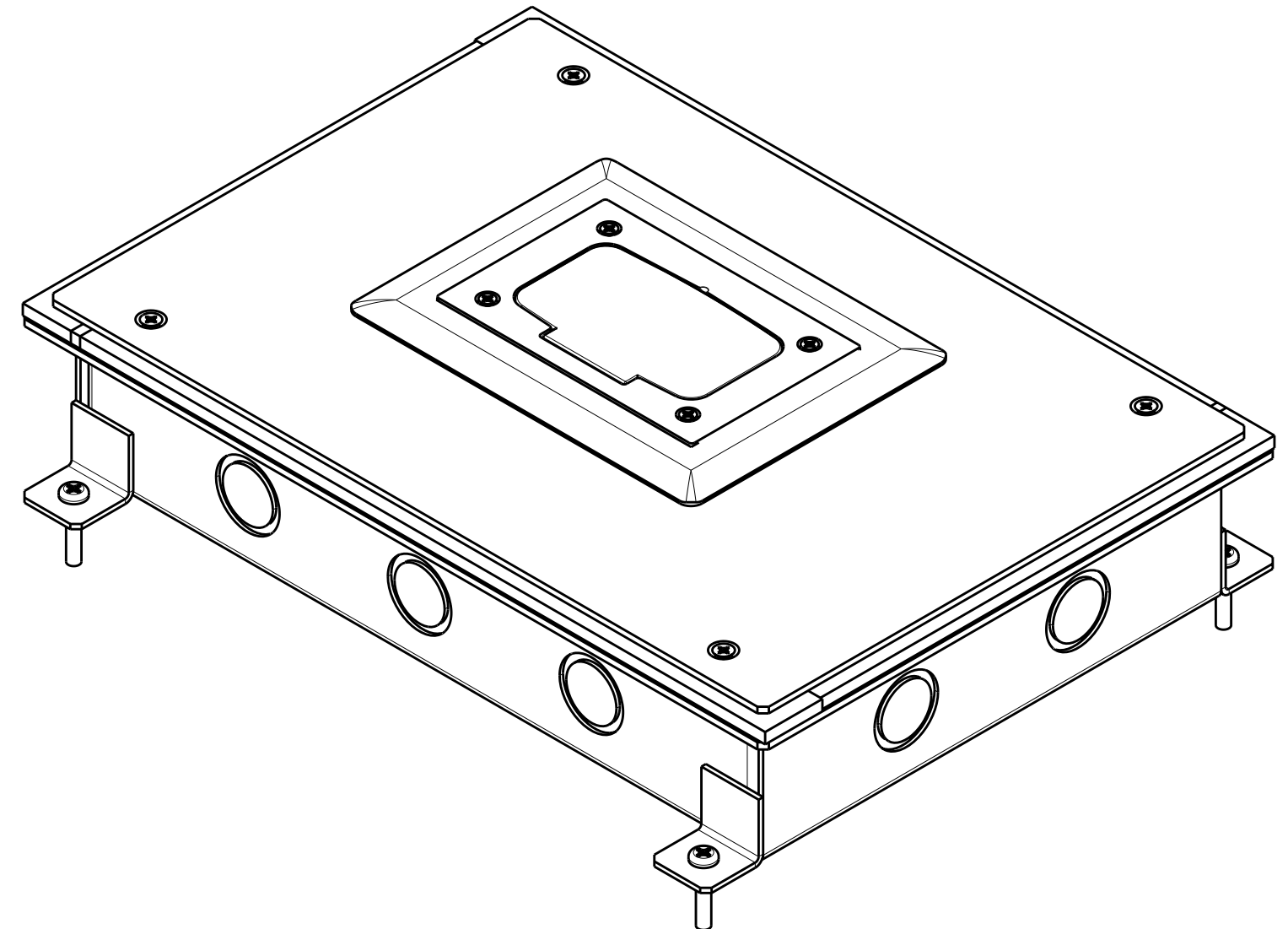

2111353-1 ASSEMBLED

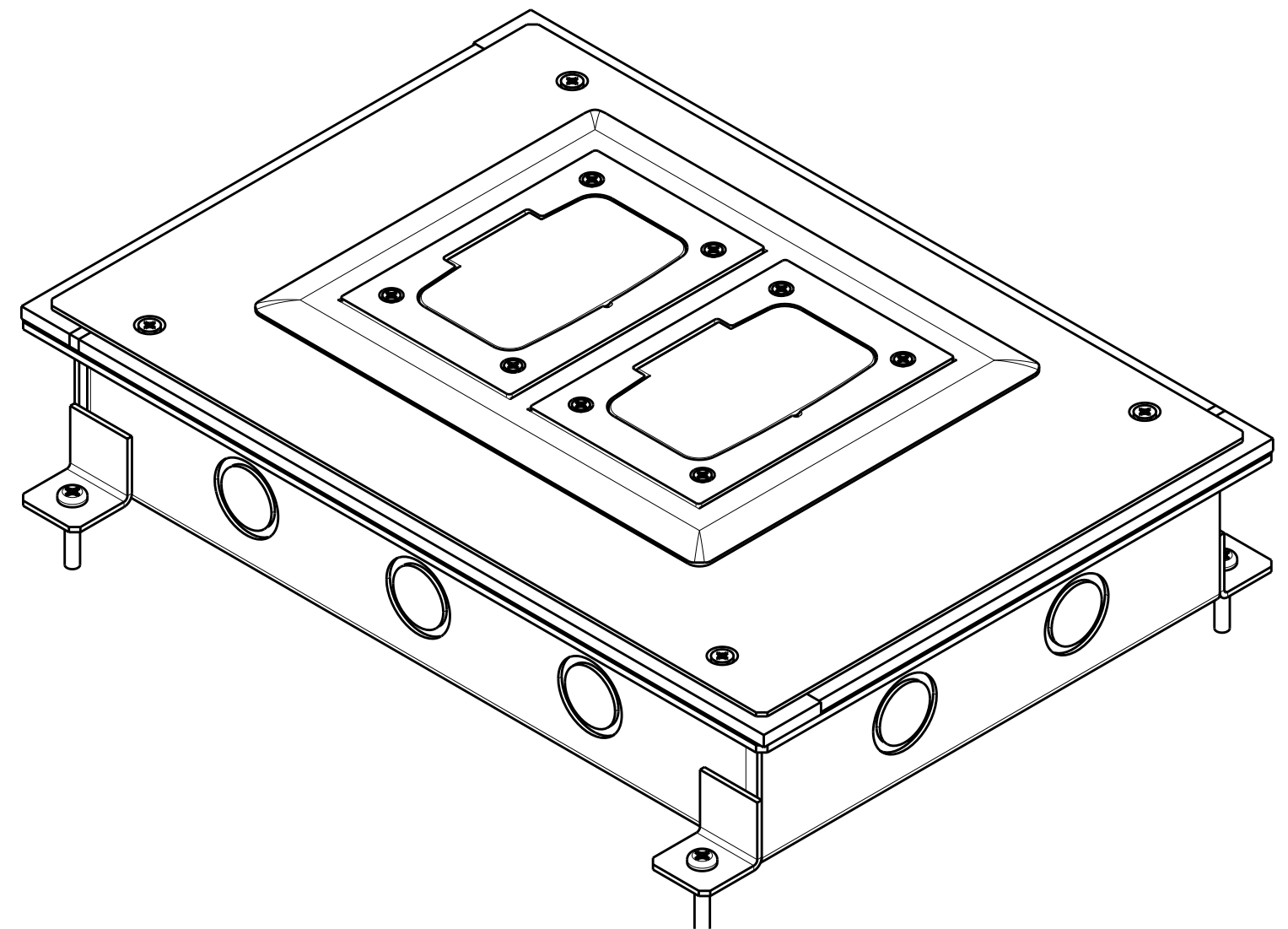

2111353-2 ASSEMBLED

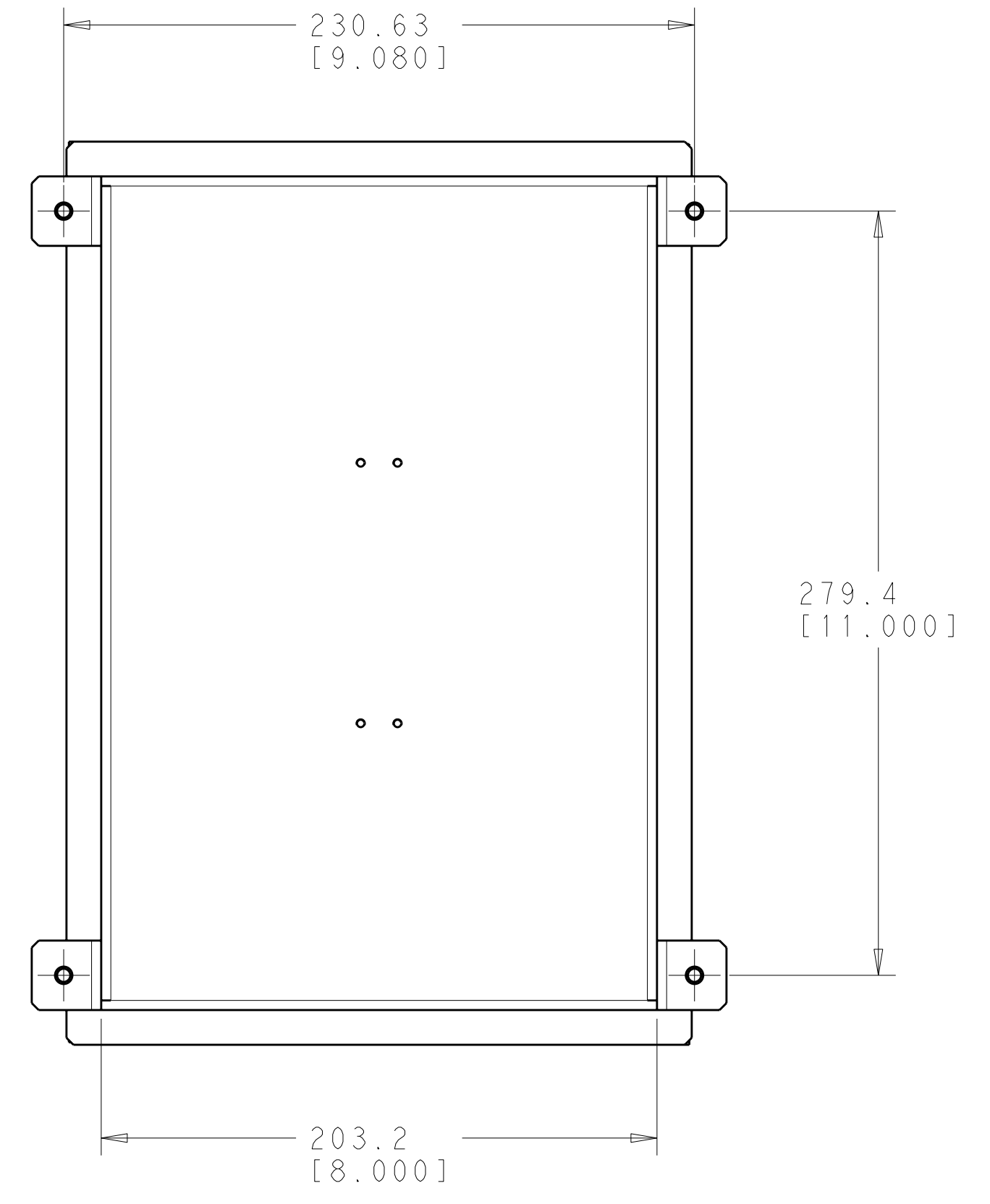
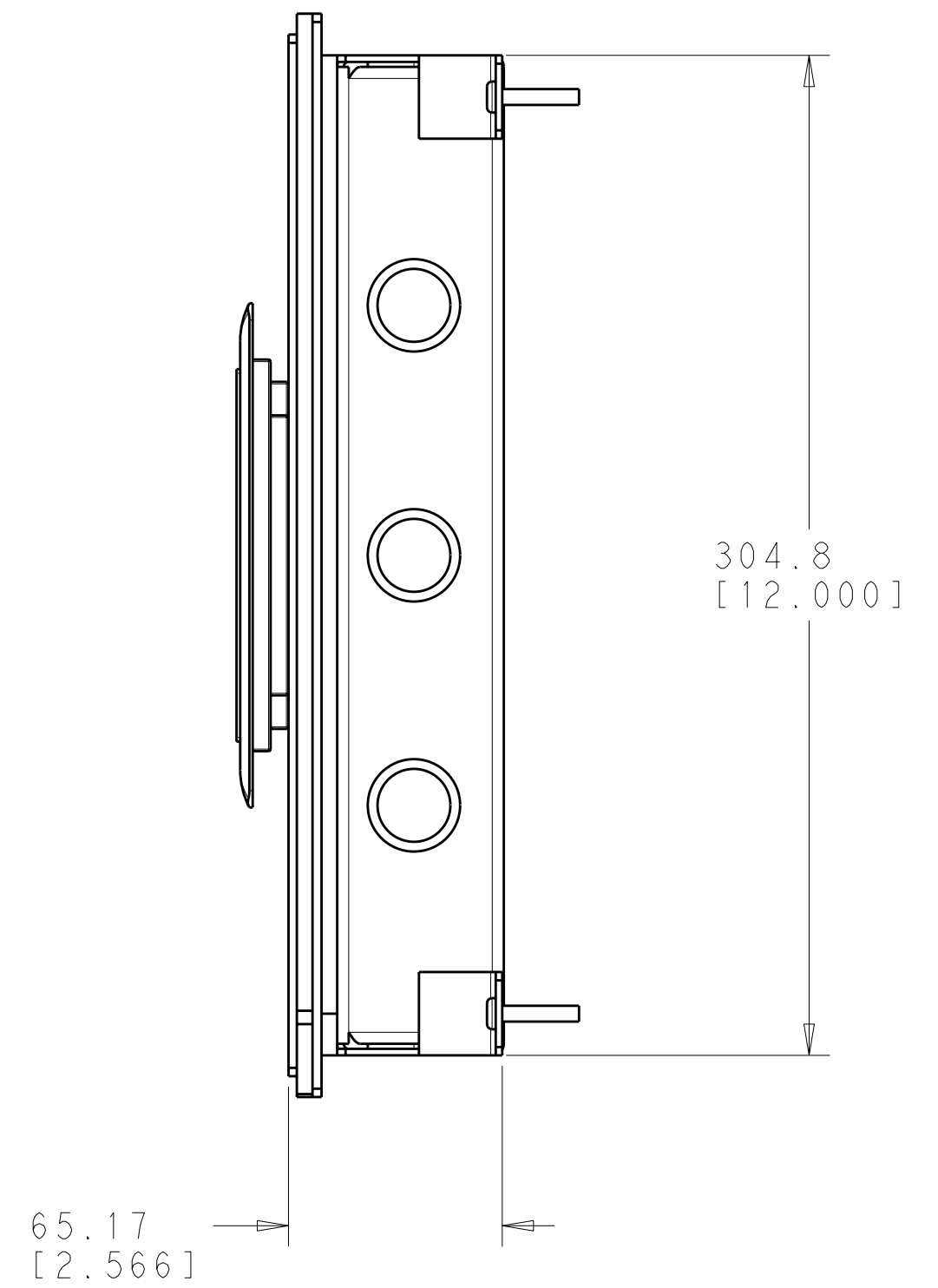
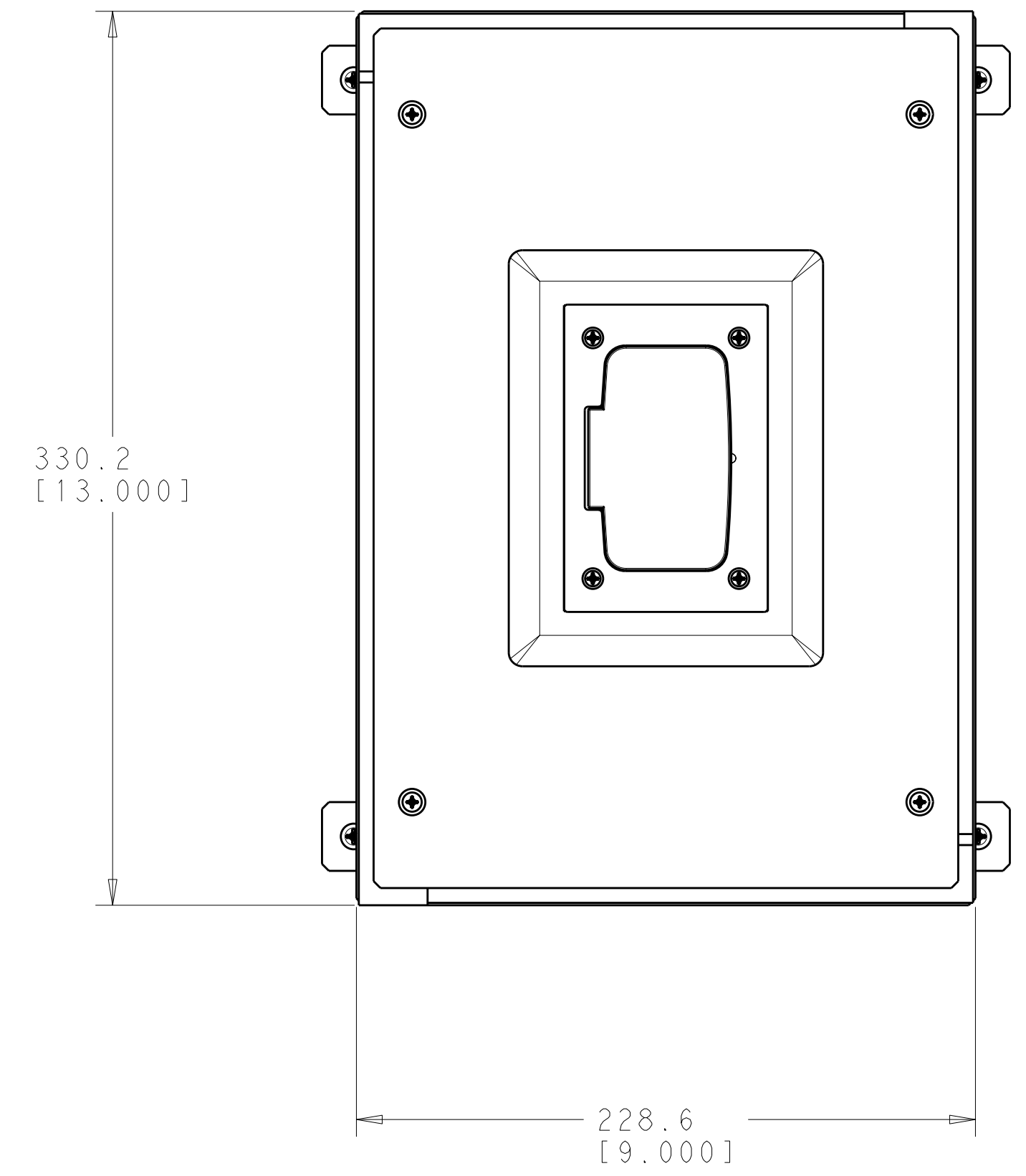

DIMENSIONS: mm [INCHES]		TOLERANCES UNLESS OTHERWISE SPECIFIED: 9 PLC ± 1 PLC ± 2 PLC ± 3 PLC ± 4 PLC ± ANGLES ± FINISH		DWN: S. GARRETT 06DEC2010 CHK: S. JONES 06DEC2010 APVD: S. JONES 06DEC2010		Tyco Electronics Corporation Harrisburg, PA 17105-3608	
MATERIAL: -		FINISH: -		PRODUCT SPEC: - APPLICATION SPEC: - WEIGHT: -		NAME: ASSEMBLY, FLUSH FLOOR OUTLET BOX WITH COVER AND CARPET RING SIZE: A100779 C=2111353 RESTRICTED TO: -	
CUSTOMER DRAWING				SCALE: 1:2		SHEET 2 OF 2 REV A	