

Sep.1.2020 Copyright 2020 HIROSE ELECTRIC CO., LTD. All Rights Reserved.  
In case of consideration for using Automotive equipment / device which demand high reliability, kindly contact our sales window correspondents.

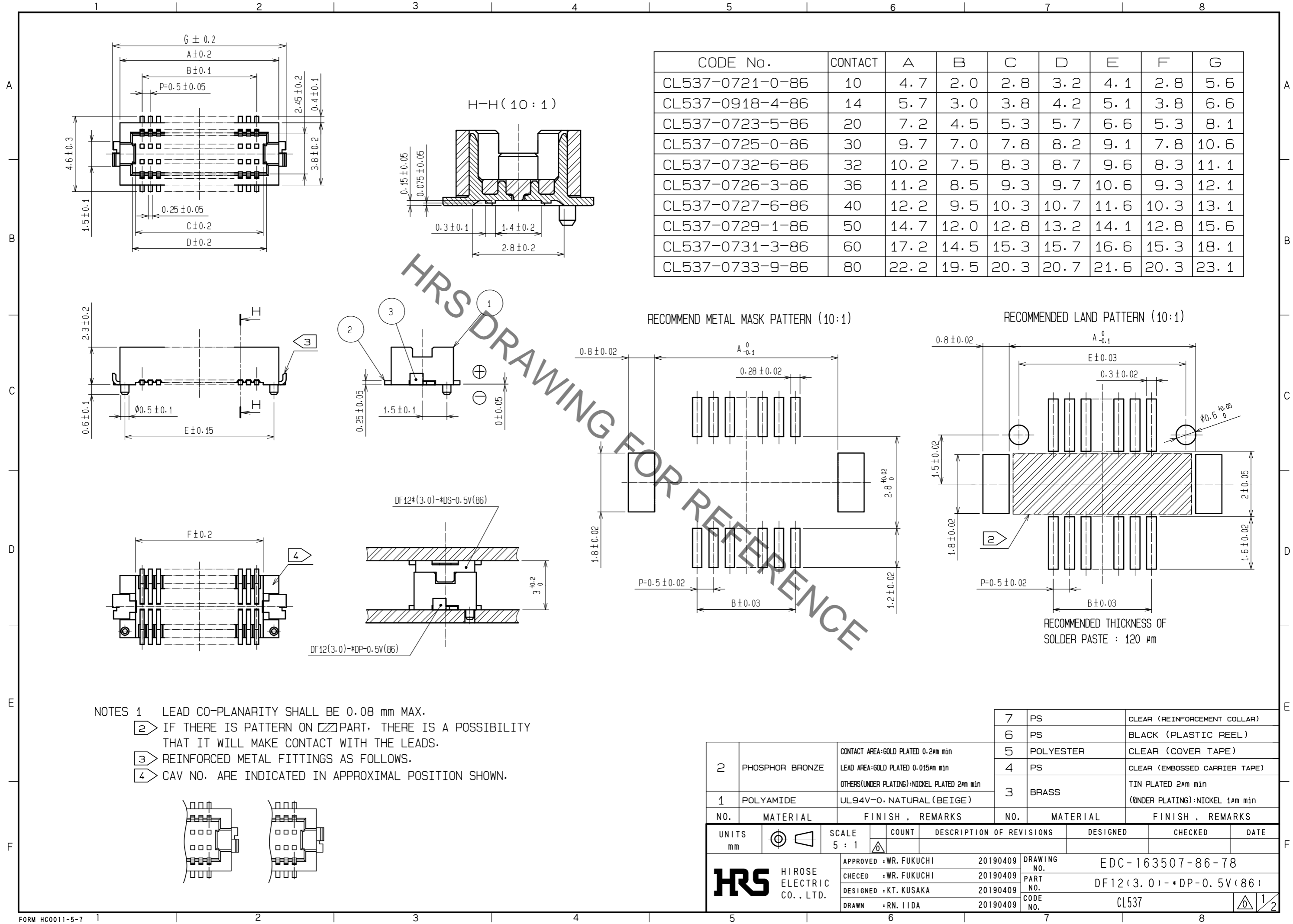

CODE No.	CONTACT	A	B	C	D	E	F	G
CL537-0721-0-86	10	4.7	2.0	2.8	3.2	4.1	2.8	5.6
CL537-0918-4-86	14	5.7	3.0	3.8	4.2	5.1	3.8	6.6
CL537-0723-5-86	20	7.2	4.5	5.3	5.7	6.6	5.3	8.1
CL537-0725-0-86	30	9.7	7.0	7.8	8.2	9.1	7.8	10.6
CL537-0732-6-86	32	10.2	7.5	8.3	8.7	9.6	8.3	11.1
CL537-0726-3-86	36	11.2	8.5	9.3	9.7	10.6	9.3	12.1
CL537-0727-6-86	40	12.2	9.5	10.3	10.7	11.6	10.3	13.1
CL537-0729-1-86	50	14.7	12.0	12.8	13.2	14.1	12.8	15.6
CL537-0731-3-86	60	17.2	14.5	15.3	15.7	16.6	15.3	18.1
CL537-0733-9-86	80	22.2	19.5	20.3	20.7	21.6	20.3	23.1

- NOTES
- LEAD CO-PLANARITY SHALL BE 0.08 mm MAX.
  - IF THERE IS PATTERN ON PART, THERE IS A POSSIBILITY THAT IT WILL MAKE CONTACT WITH THE LEADS.
  - REINFORCED METAL FITTINGS AS FOLLOWS.
  - CAV NO. ARE INDICATED IN APPROXIMAL POSITION SHOWN.

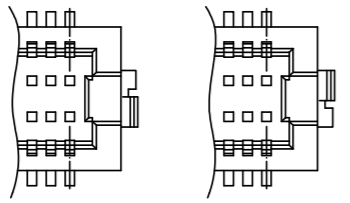

RECOMMEND METAL MASK PATTERN (10:1)

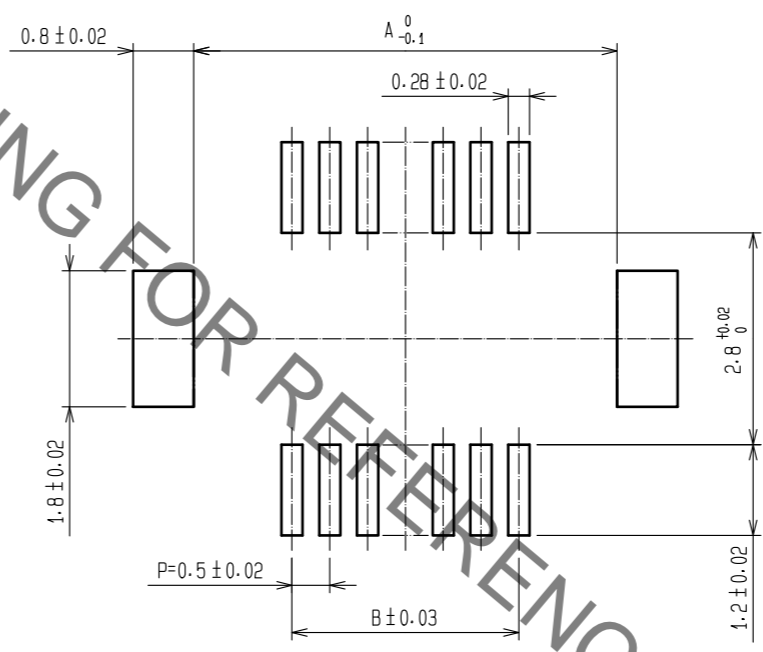

RECOMMENDED LAND PATTERN (10:1)

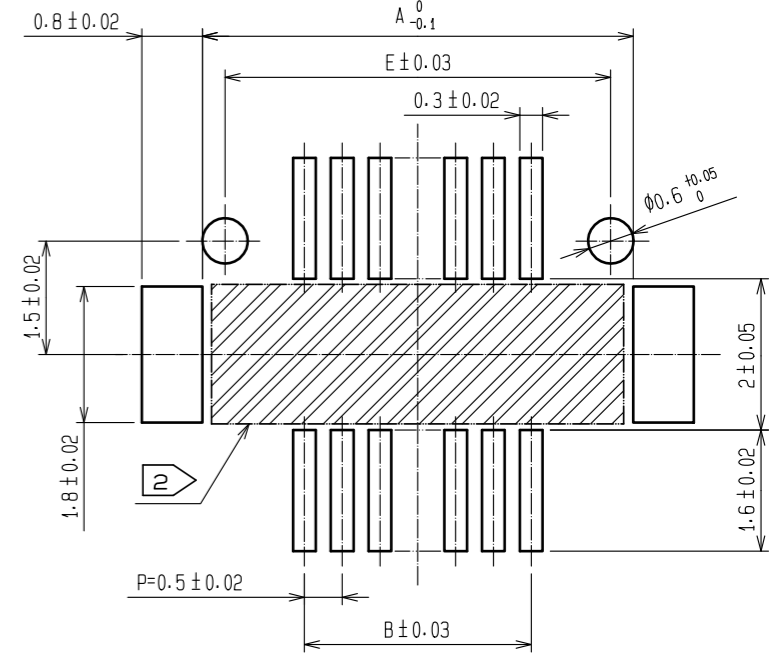

RECOMMENDED THICKNESS OF SOLDER PASTE : 120 μm

NO.	MATERIAL	FINISH . REMARKS	NO.	MATERIAL	FINISH . REMARKS
2	PHOSPHOR BRONZE	CONTACT AREA:GOLD PLATED 0.2μm min LEAD AREA:GOLD PLATED 0.015μm min OTHERS(UNDER PLATING):NICKEL PLATED 2μm min	7	PS	CLEAR (REINFORCEMENT COLLAR)
1	POLYAMIDE	UL94V-0, NATURAL (BEIGE)	6	PS	BLACK (PLASTIC REEL)
			5	POLYESTER	CLEAR (COVER TAPE)
			4	PS	CLEAR (EMBOSSED CARRIER TAPE)
			3	BRASS	TIN PLATED 2μm min (UNDER PLATING):NICKEL 1μm min

  

UNITS	SCALE	COUNT	DESCRIPTION OF REVISIONS	DESIGNED	CHECKED	DATE
mm	5 : 1	1				

<b>HRS</b> HIROSE ELECTRIC CO., LTD.	APPROVED : WR. FUKUCHI	20190409	DRAWING NO.	EDC-163507-86-78
	CHECED : WR. FUKUCHI	20190409	PART NO.	DF12(3.0)-*DP-0.5V(86)
	DESIGNED : KT. KUSAKA	20190409	CODE NO.	CL537
	DRAWN : RN. IIDA	20190409		

Sep.1.2020 Copyright 2020 HIROSE ELECTRIC CO., LTD. All Rights Reserved.  
In case of consideration for using Automotive equipment / device which demand high reliability, kindly contact our sales window correspondents.

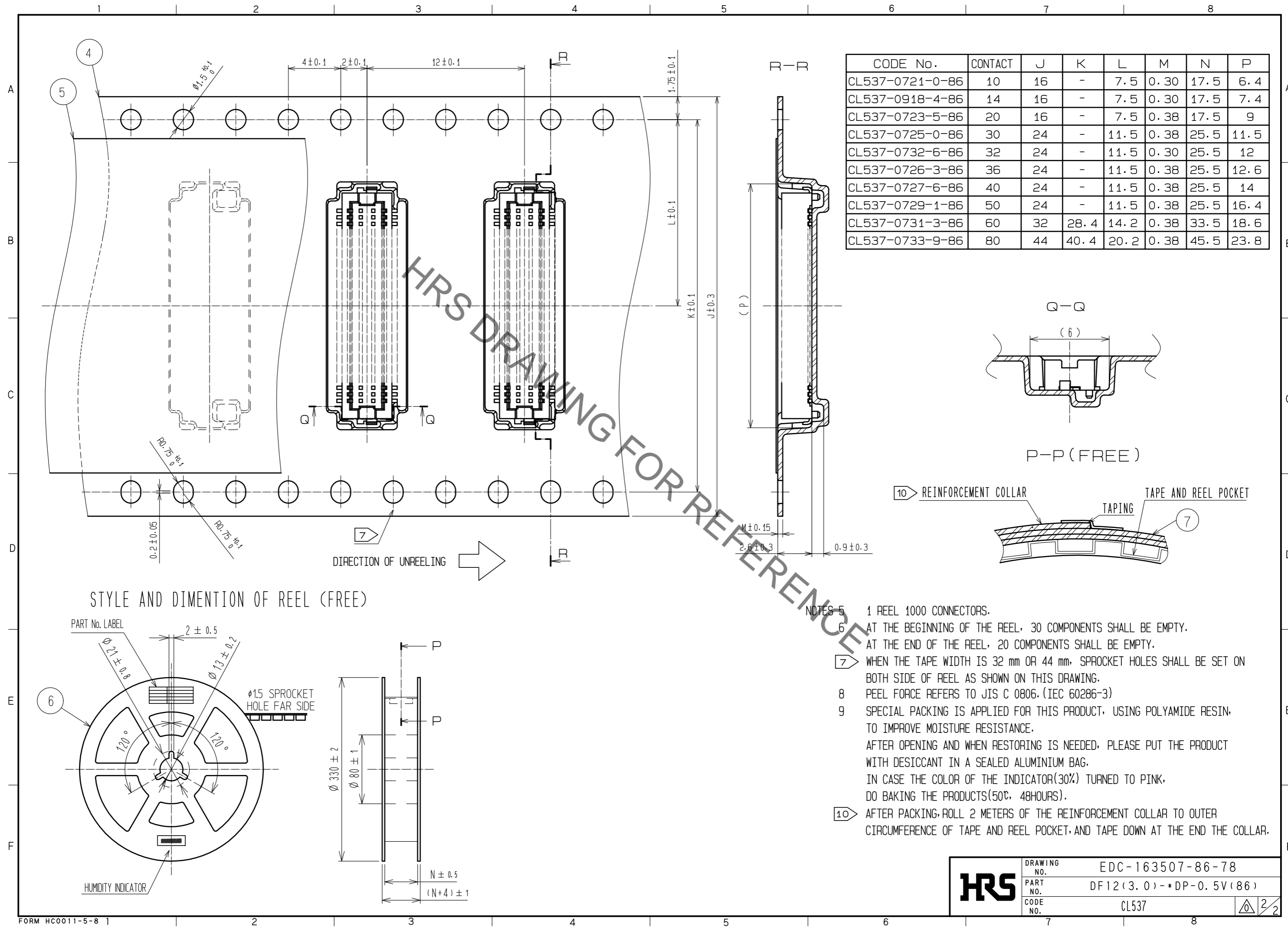

CODE No.	CONTACT	J	K	L	M	N	P
CL537-0721-0-86	10	16	-	7.5	0.30	17.5	6.4
CL537-0918-4-86	14	16	-	7.5	0.30	17.5	7.4
CL537-0723-5-86	20	16	-	7.5	0.38	17.5	9
CL537-0725-0-86	30	24	-	11.5	0.38	25.5	11.5
CL537-0732-6-86	32	24	-	11.5	0.30	25.5	12
CL537-0726-3-86	36	24	-	11.5	0.38	25.5	12.6
CL537-0727-6-86	40	24	-	11.5	0.38	25.5	14
CL537-0729-1-86	50	24	-	11.5	0.38	25.5	16.4
CL537-0731-3-86	60	32	28.4	14.2	0.38	33.5	18.6
CL537-0733-9-86	80	44	40.4	20.2	0.38	45.5	23.8

- NOTES
- 5 1 REEL 1000 CONNECTORS.
  - 6 AT THE BEGINNING OF THE REEL, 30 COMPONENTS SHALL BE EMPTY.  
AT THE END OF THE REEL, 20 COMPONENTS SHALL BE EMPTY.
  - 7 WHEN THE TAPE WIDTH IS 32 mm OR 44 mm, SPROCKET HOLES SHALL BE SET ON BOTH SIDE OF REEL AS SHOWN ON THIS DRAWING.
  - 8 PEEL FORCE REFERS TO JIS C 0806. (IEC 60286-3)
  - 9 SPECIAL PACKING IS APPLIED FOR THIS PRODUCT, USING POLYAMIDE RESIN, TO IMPROVE MOISTURE RESISTANCE.  
AFTER OPENING AND WHEN RESTORING IS NEEDED, PLEASE PUT THE PRODUCT WITH DESICCANT IN A SEALED ALUMINIUM BAG.  
IN CASE THE COLOR OF THE INDICATOR(30%) TURNED TO PINK, DO BAKING THE PRODUCTS(50°C, 48HOURS).
  - 10 AFTER PACKING, ROLL 2 METERS OF THE REINFORCEMENT COLLAR TO OUTER CIRCUMFERENCE OF TAPE AND REEL POCKET, AND TAPE DOWN AT THE END THE COLLAR.

<b>HRS</b>	DRAWING NO.	EDC-163507-86-78
	PART NO.	DF12(3.0)-*DP-0.5V(86)
	CODE NO.	CL537