

Sep.1.2020 Copyright 2020 HIROSE ELECTRIC CO., LTD. All Rights Reserved.
In case of consideration for using Automotive equipment / device which demand high reliability, kindly contact our sales window correspondents.

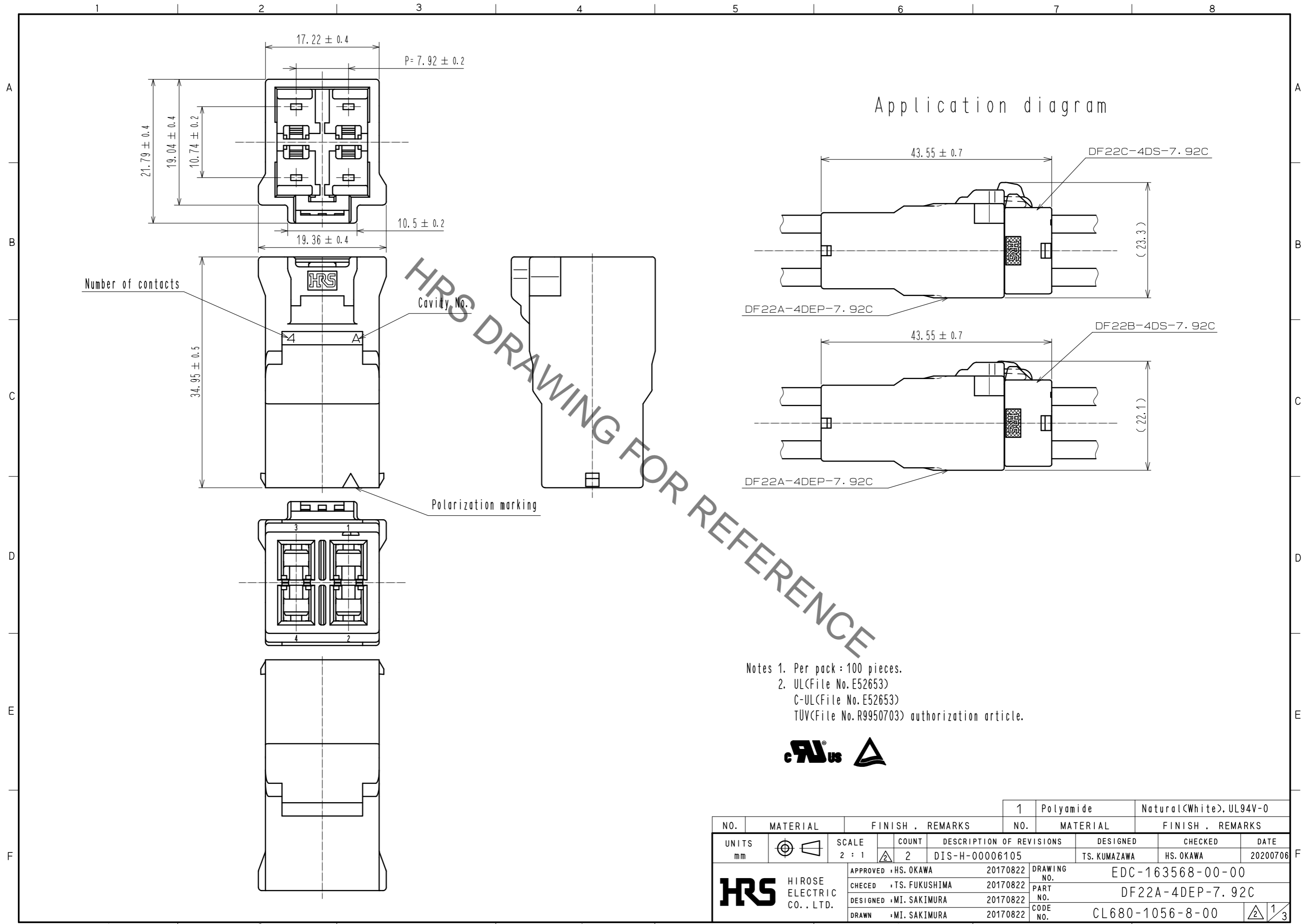

Application diagram

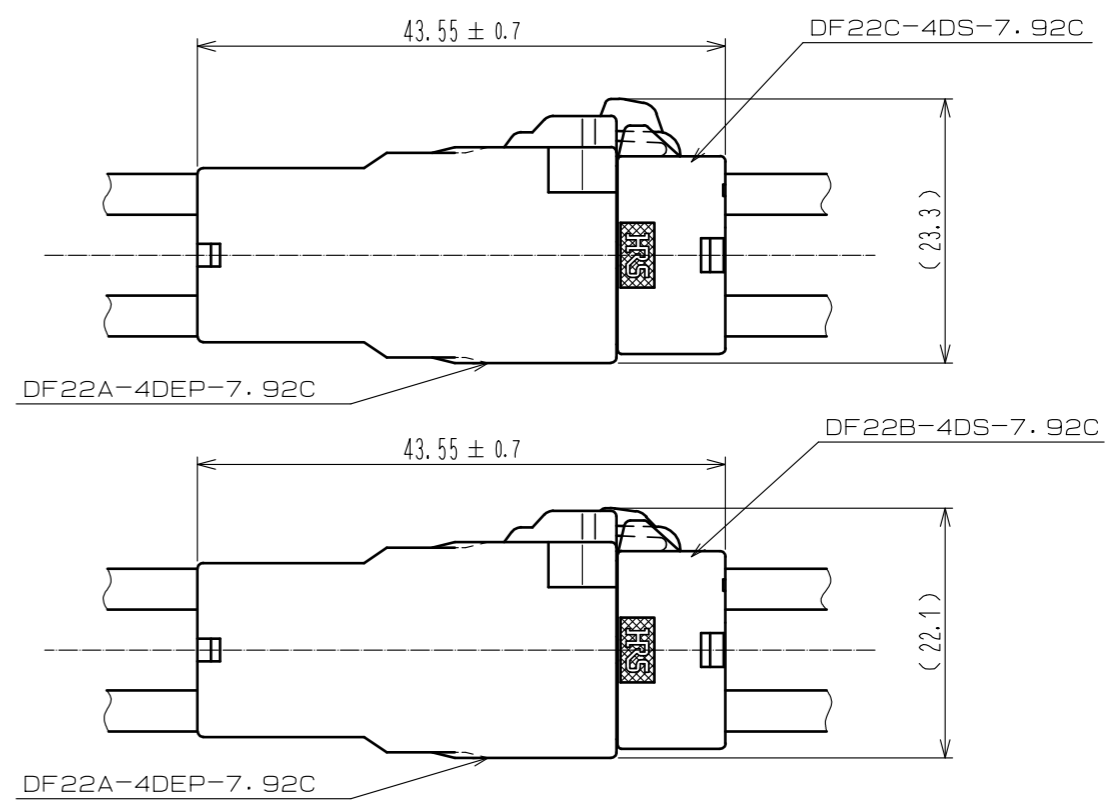

- Notes 1. Per pack : 100 pieces.
2. UL(File No. E52653)
C-UL(File No. E52653)
TUV(File No. R9950703) authorization article.



NO.	MATERIAL	FINISH . REMARKS	NO.	MATERIAL	FINISH . REMARKS		
1	Polyamide			Natural(White).UL94V-0			
UNITS	mm	SCALE	COUNT	DESCRIPTION OF REVISIONS	DESIGNED	CHECKED	DATE
		2 : 1	2	DIS-H-00006105	TS. KUMAZAWA	HS. OKAWA	20200706
APPROVED : HS. OKAWA 20170822			DRAWING NO. EDC-163568-00-00				
CHECKED : TS. FUKUSHIMA 20170822			PART NO. DF22A-4DEP-7.92C				
DESIGNED : MI. SAKIMURA 20170822			CODE NO. CL680-1056-8-00				
DRAWN : MI. SAKIMURA 20170822							

In case of consideration for using Automotive equipment / device which demand high reliability, kindly contact our sales window correspondents.

Sep.1.2020 Copyright 2020 HIROSE ELECTRIC CO., LTD. All Rights Reserved.



Precautions

Notification for harness assembly

- 1) When inserting the crimping terminal to the In-line plug, please do not tilt the crimping terminal or twist the cable. Insertion at tilted angles or twisting the cable may cause deformation of the crimping terminal or In-line plug.
- 2) After inserting the crimping terminal to the In-line plug, please make sure that the lance has been hooked with pulling the cable lightly. When checking the hook, please avoid bending the cable for preventing terminal drop-off.

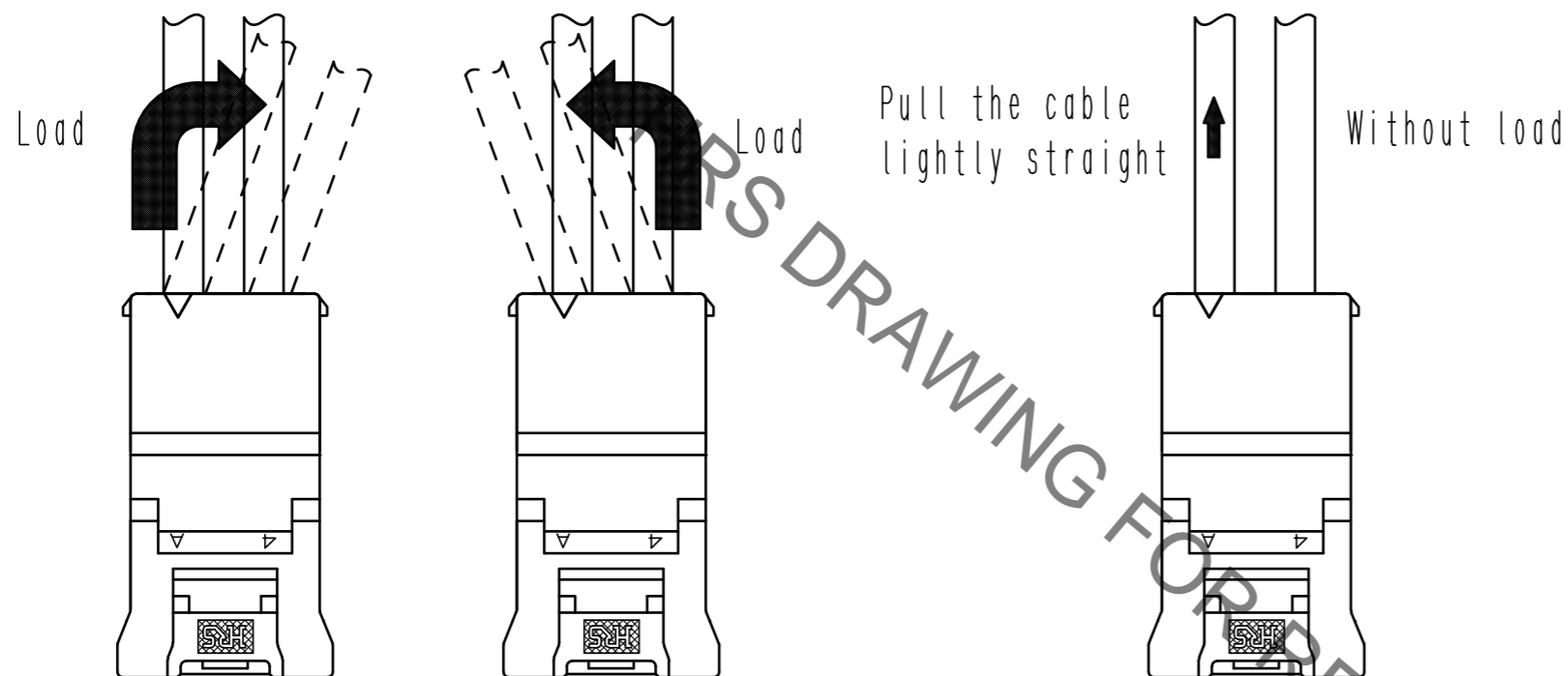

NG

OK

- 3) Bundle cables/Cable Cables
Recommend bundle and strip position of cables are 100 mm or more.
Bundling close to the connectors may cause terminal drop-off, breaking cables and unstable connection.

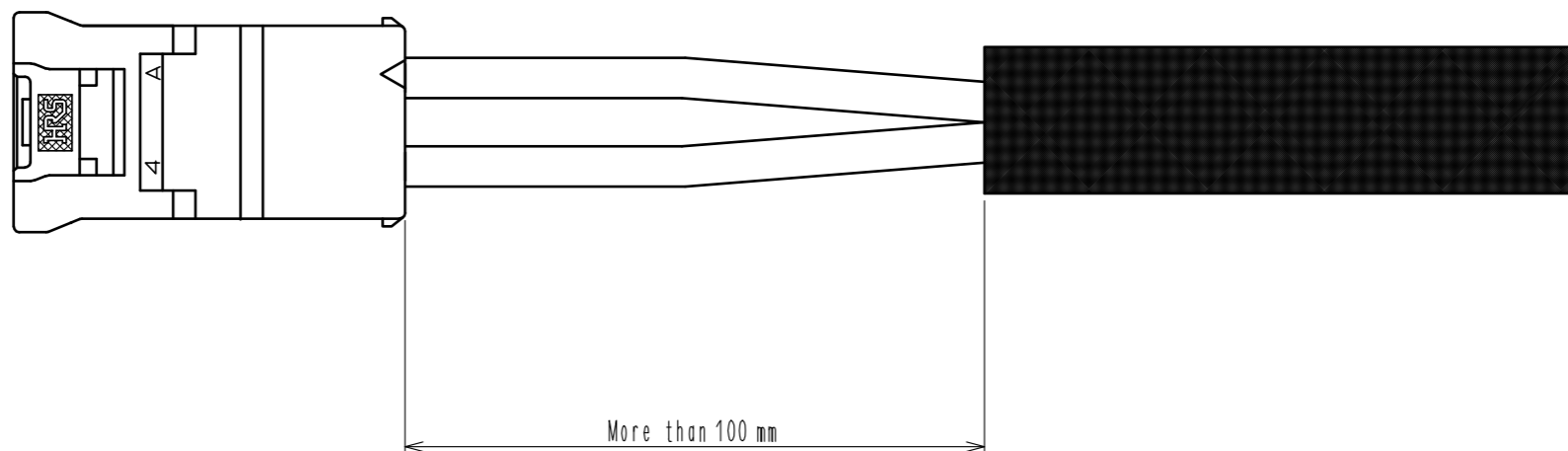

HRS	DRAWING NO.	EDC-163568-00-00
	PART NO.	DF22A-4DEP-7.92C
	CODE NO.	CL680-1056-8-00
		3/4

Sep.1.2020 Copyright 2020 HIROSE ELECTRIC CO., LTD. All Rights Reserved.
In case of consideration for using Automotive equipment / device which demand high reliability, kindly contact our sales window correspondents.

⚠️ Precautions

◆ Notification for Insertion/Extraction

- 1) Please insert/extract the crimping socket straight to the mating connector.
Insertion/Extraction at tilted angles applies load concentration to the connector end and may cause deformation (at connection area, socket and header case, etc). There is firing risk using this kind of deformed connector.

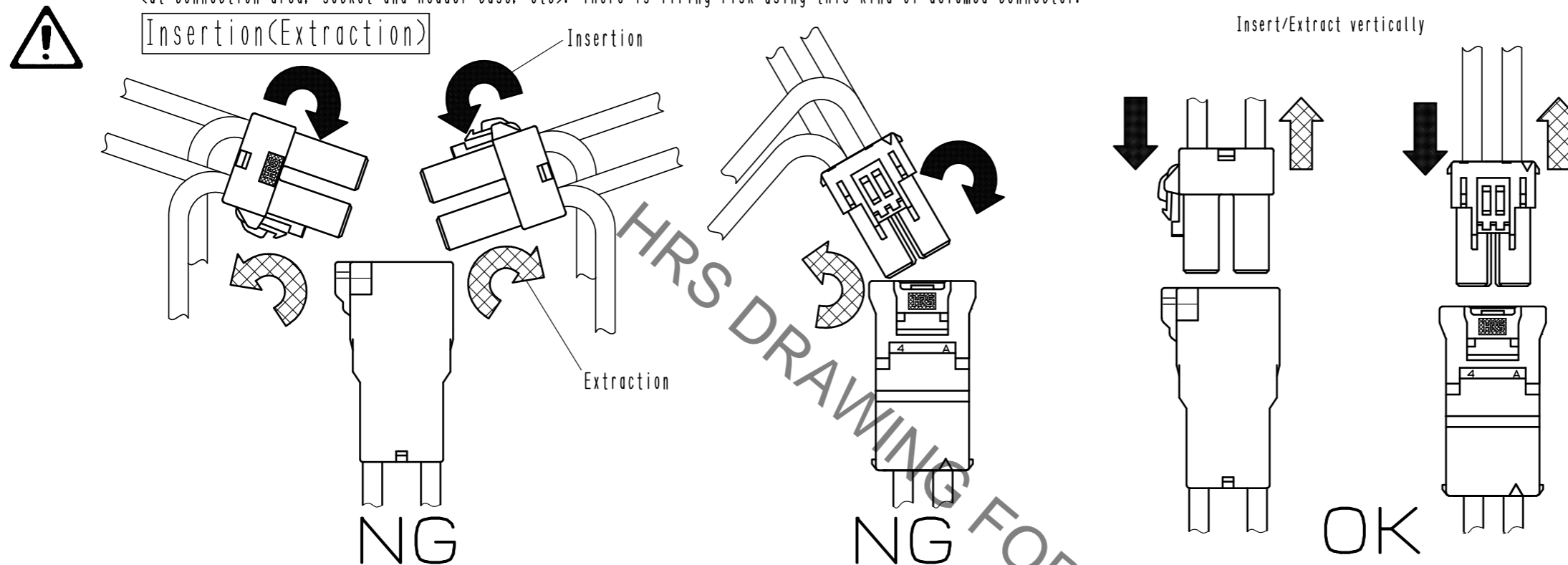

- 2) When it is hard to extract, please lightly insert the connector beforehand and then pull it with releasing the lock.
Forced extraction has a risk of connector breakage.

◆ Notification of wiring

- 1) When using a thick cable, short cable length and bending close to the connector end, these load concentration may cause deformation.
Please note that there is firing risk using deformed connector.
When installing, please refrain from stress concentration such as cable bending close to the connector end or cable twisting.

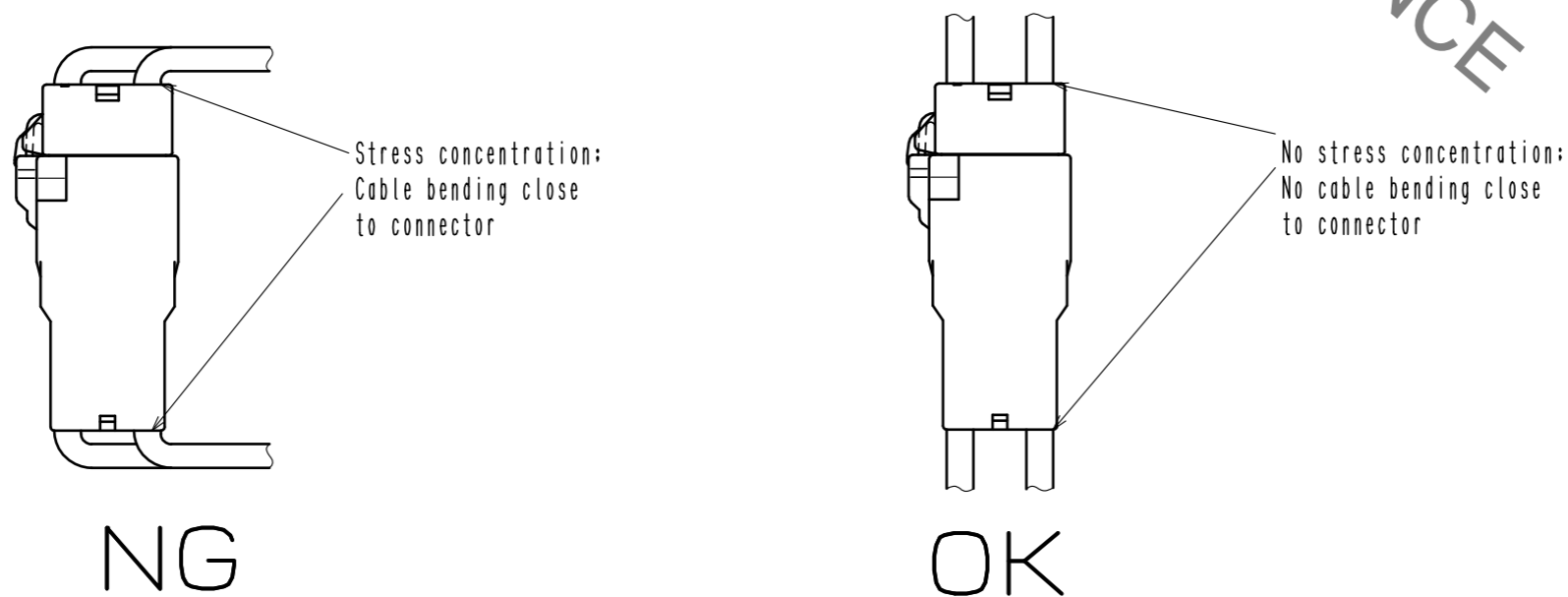

HRS	DRAWING NO.	EDC-163568-00-00	
	PART NO.	DF22A-4DEP-7.92C	
	CODE NO.	CL680-1056-8-00	
			⚠️ 4/4