

Sep.1.2020 Copyright 2020 HIROSE ELECTRIC CO., LTD. All Rights Reserved.
In case of consideration for using Automotive equipment / device which demand high reliability, kindly contact our sales window correspondents.

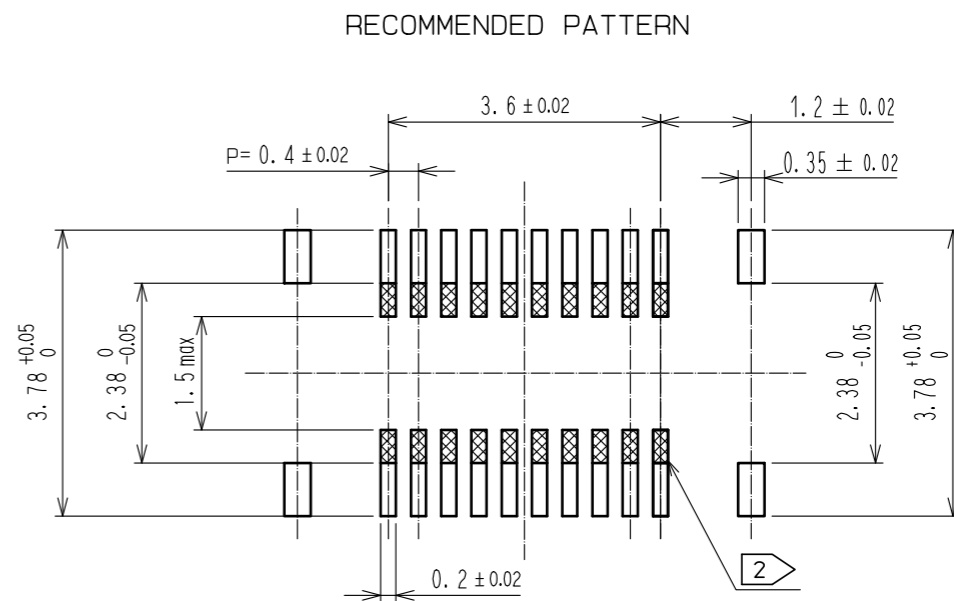

RECOMMENDED METAL MASK THICKNESS : 120μm
RECOMMENDED METAL MASK OPENING RATIO : 80% FOR LEAD PAD

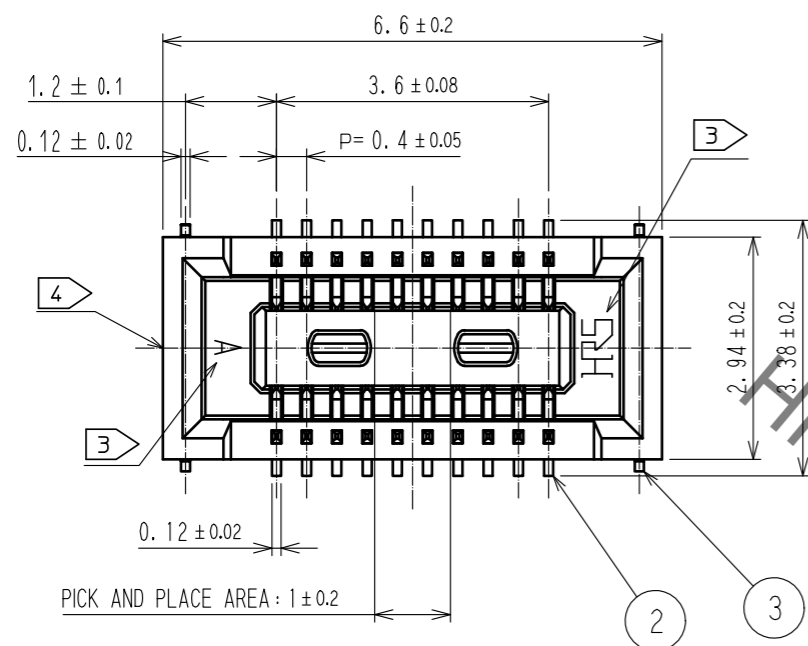
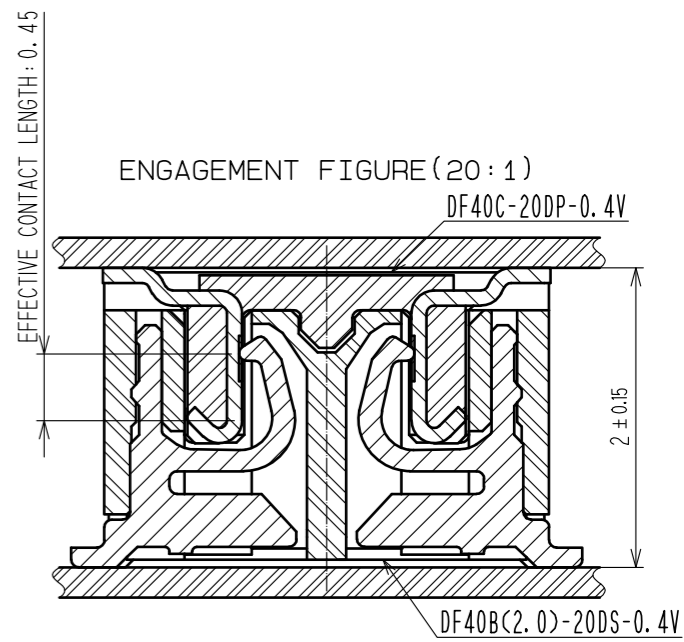
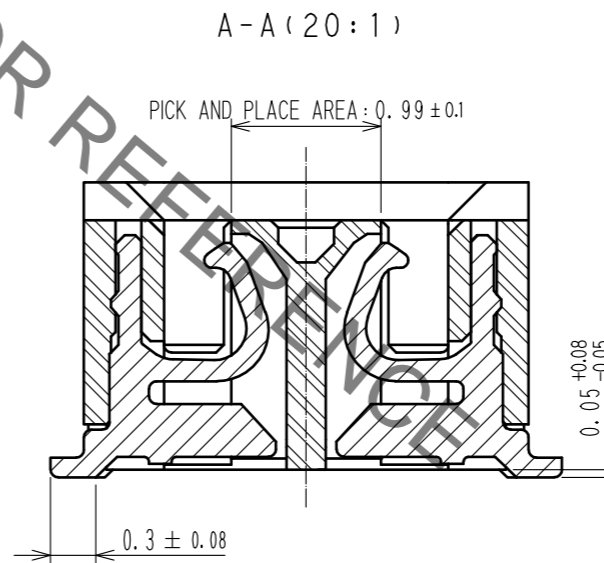
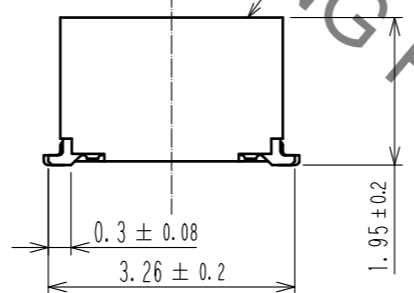
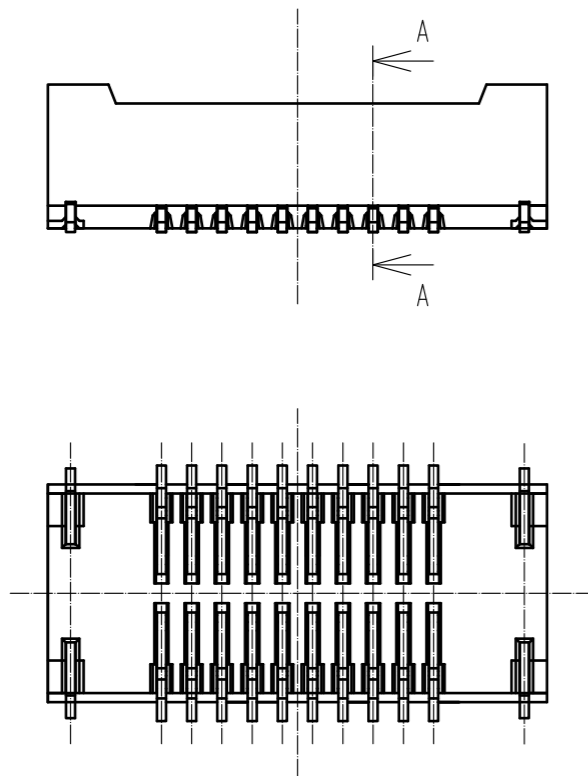

- NOTES) 1. ALL LEADS AND REINFORCED METAL FITTINGS CO-PLANARITY SHALL BE 0.1MAX.
 2. IS NO PATTERN AREA OTHER THAN THE SAME CIRCUIT.
 3. HRS MARK AND CAV NO. ARE LOCATED IN APPROXIMAL AREA.
 4. GATE POSITIONS IS LOCATED IN APPROXIMAL AREA.
 A PART OF THE WALL MAY BE NOTCHED FOR SETTING GATE.

2	PHOSPHOR BRONZE	CONTACT AREA:GOLD 0.1μm MIN SMT LEAD:GOLD 0.05μm MIN UNDERPLATING:NICKEL 1μm MIN	7	PS	CLEAR, REINFORCEMENT COLLAR		
1	LCP	UL94V-0, BLACK	6	PS	BLACK, PLASTIC REEL		
			5	POLYESTER	CLEAR, COVER TAPE		
			4	PS	CLEAR, EMBOSSED CARRIER TAPE		
			3	PHOSPHOR BRONZE	SURFACE:GOLD 0.05μm MIN UNDERPLATING:NICKEL 1μm MIN		
NO.	MATERIAL	FINISH, REMARKS	NO.	MATERIAL	FINISH, REMARKS		
UNITS mm		SCALE 10:1	COUNT	DESCRIPTION OF REVISIONS	DESIGNED	CHECKED	DATE
HRS HIROSE ELECTRIC CO., LTD.		APPROVED : WR. FUKUCHI 20200220	DRAWING NO. EDC-354974-75-02				
		CHECED : TS. MIYAZAKI 20200220	PART NO. DF40B(2.0)-20DS-0.4V(75)				
		DESIGNED : RH. KAGAMI 20200220	CODE NO. CL684-4213-6-75				
		DRAWN : RH. KAGAMI 20200220					

Sep.1.2020 Copyright 2020 HIROSE ELECTRIC CO., LTD. All Rights Reserved.
In case of consideration for using Automotive equipment / device which demand high reliability, kindly contact our sales window correspondents.

EMBOSSED CARRIER TAPE DIMENSIONS (5:1)

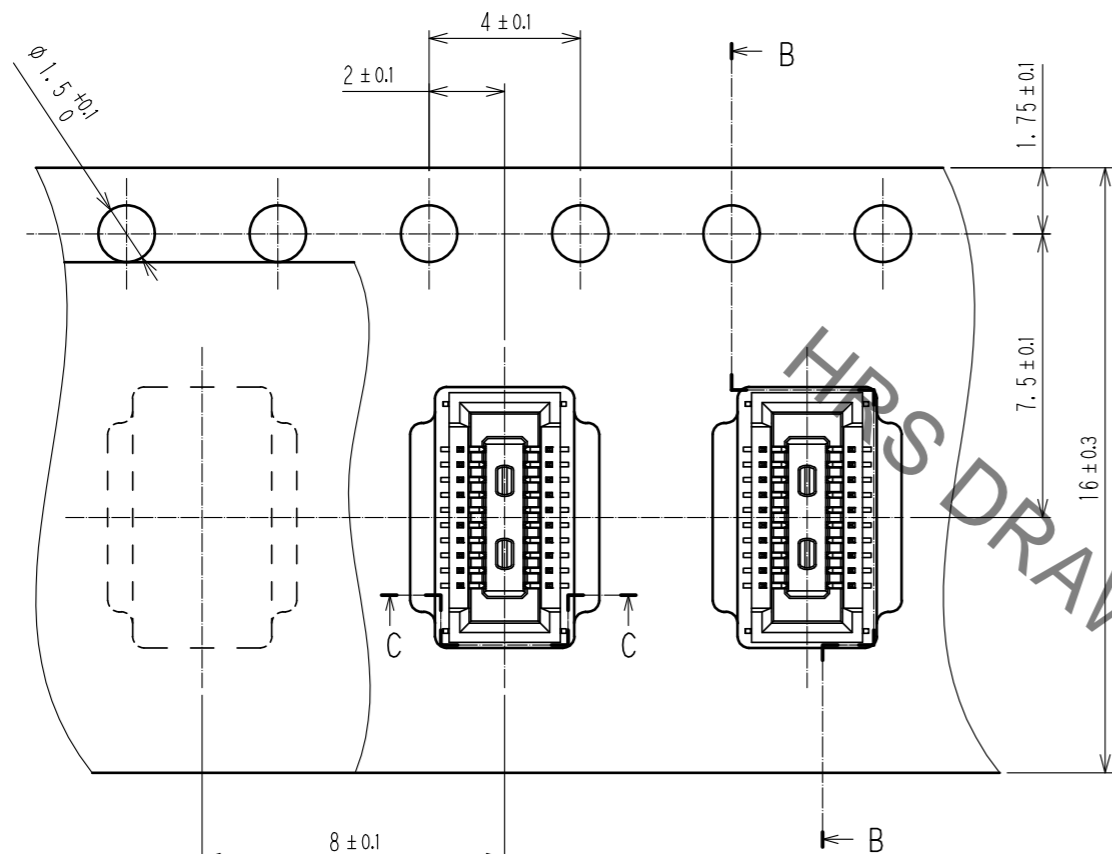

DIRECTION OF UNREELING \rightarrow

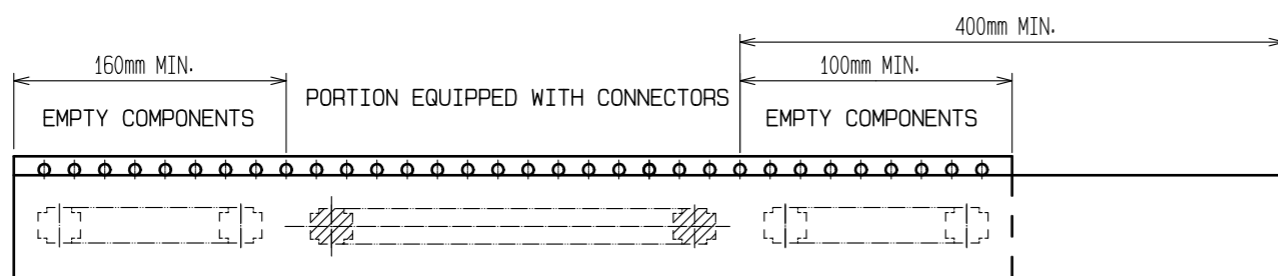
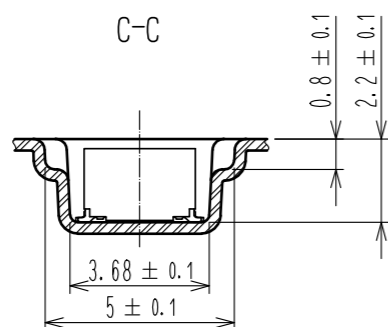

TRAILER

7 TAPING

LEADER

STYLE AND DIMENSION OF REEL (FREE)

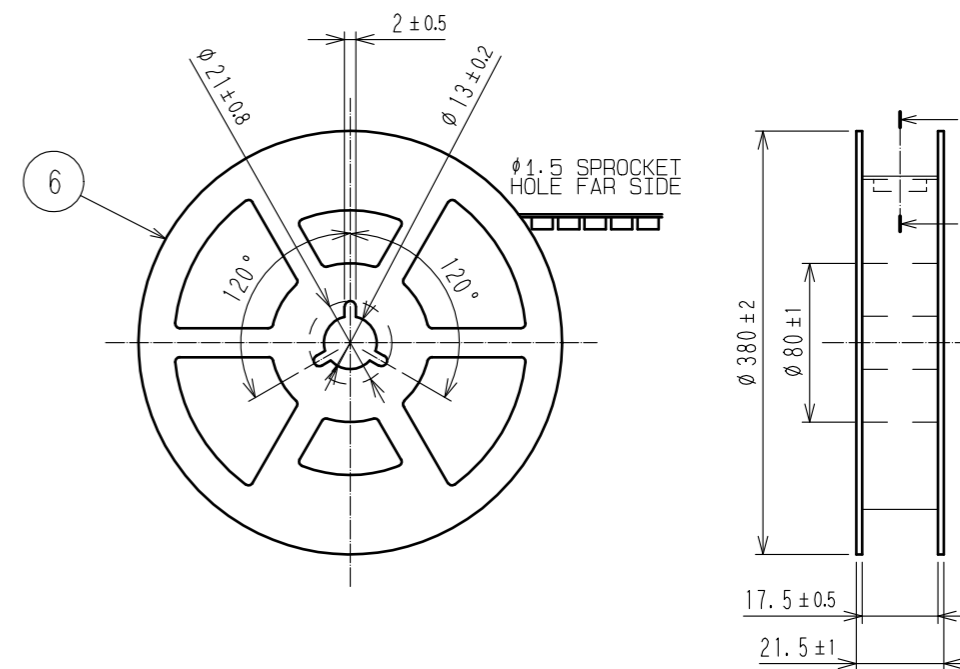

D-D(FREE)

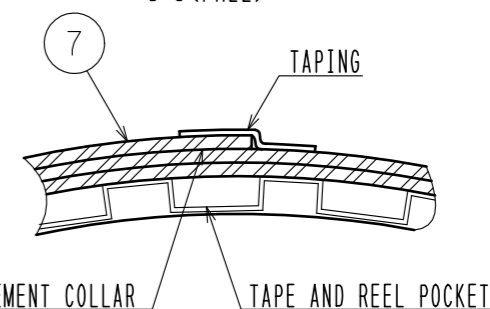

- NOTES) 5. PER REEL 4000 CONNECTORS.
6. THE DIMENSIONS IN PARENTHESES ARE FOR REFERENCE.
7 REFER TO JIS C 0806(IEC 60286-3)(PACKING OF COMPONENTS FOR AUTOMATIC HANDLING)
8 AFTRE PACKAGING, ROLL 2 METERS OF THE REINFORCEMENT COLLAR TO OUTER CIRCUMFERENCE OF TAPE AND REEL POCKET. AND TAPE DOWN AT THE END THE COLLAR.

HRS	DRAWING NO.	EDC-354974-75-02
	PART NO.	DF40B(2.0)-20DS-0.4V(75)
	CODE NO.	CL684-4213-6-75
		\triangle 2/2