

Sep.1.2020 Copyright 2020 HIROSE ELECTRIC CO., LTD. All Rights Reserved.  
In case of consideration for using Automotive equipment / device which demand high reliability, kindly contact our sales window correspondents.

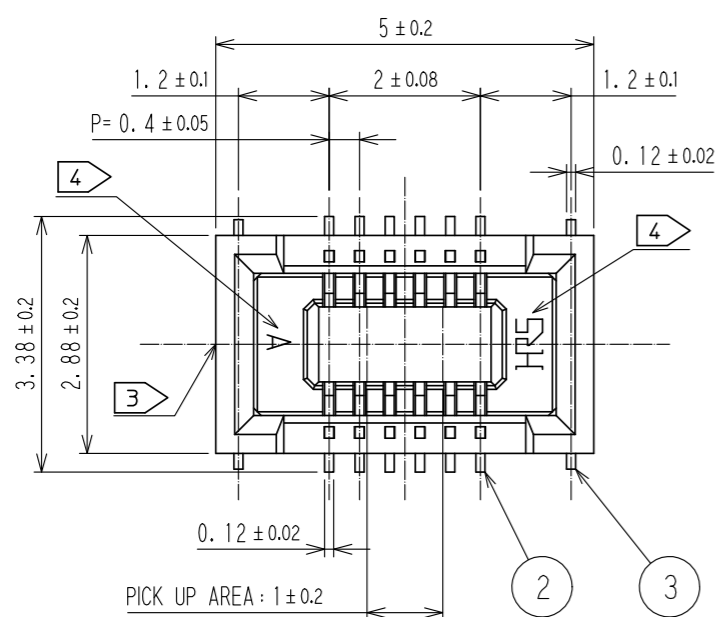

RECOMMENDED PATTERN

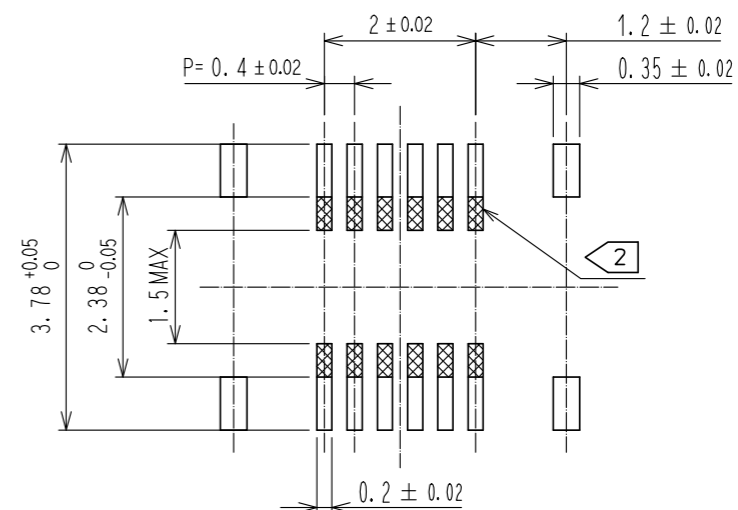

RECOMMENDED METAL MASK THICKNESS : 120 μm  
RECOMMENDED METAL MASK OPENING RATIO : 80% FOR LEAD PAD

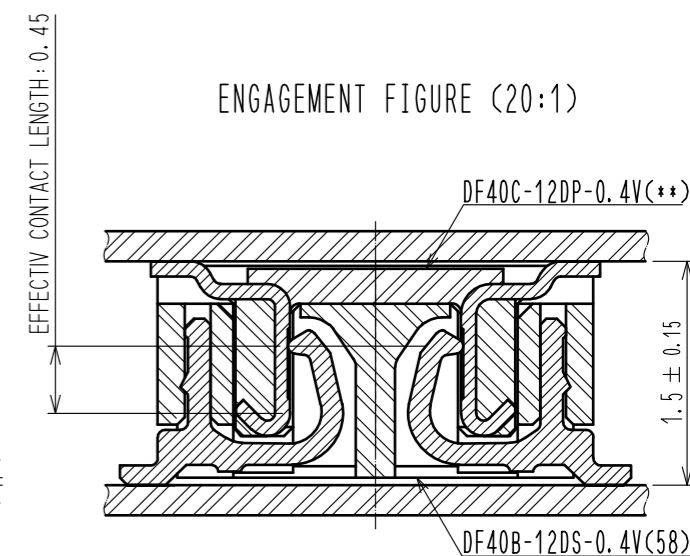
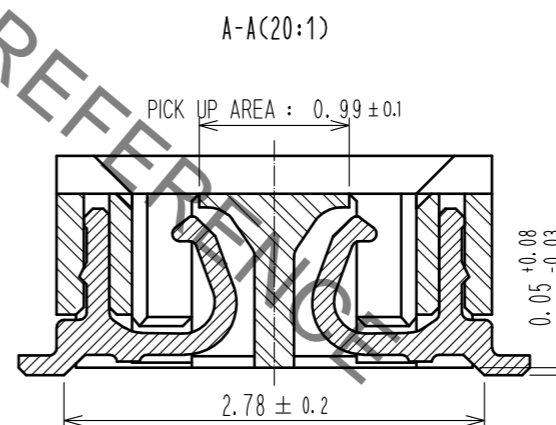
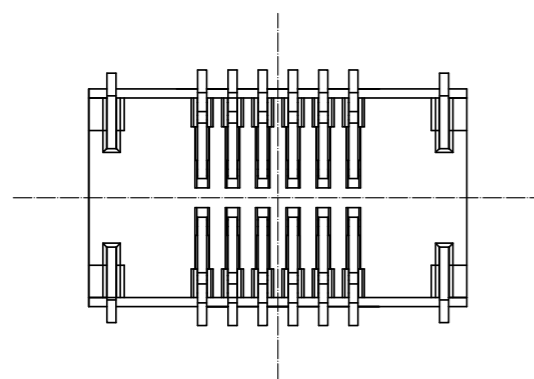
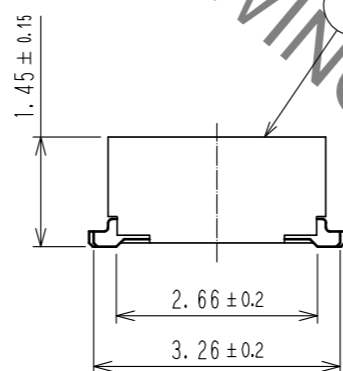
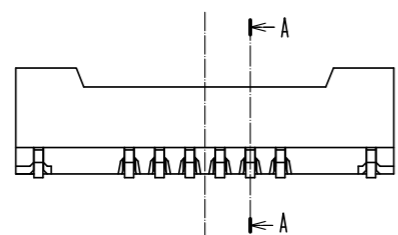

- NOTES 1. ALL LEADS CO-PLANARITY SHALL BE 0.1 MAX.  
 2. IS NO PATTERN AREA OTHER THAN THE SAME CIRCUIT.  
 3. GATE POSITION IS POSITIONED IN APPROXIMAL AREA SHOWN.  
 4. HRS MARK AND CAV NO. IS INDICATED IN APPROX POSITION SHOWN.

2	PHOSPHOR BRONZE	CONTACT AREA:GOLD 0.05 μm MIN SMT LEAD:GOLD 0.05 μm MIN UNDERPLATING:NICKEL 1 μm MIN	7	PS	CLEAR, REINFORCEMENT COLLAR			
1	LCP	BLACK, UL94V-0	6	PS	BLACK, PLASTIC REEL			
			5	POLYESTER	CLEAR, COVER TAPE			
			4	PS	CLEAR, EMBOSSED CARRIER TAPE			
			3	PHOSPHOR BRONZE	GOLD 0.05 μm MIN			
NO.	MATERIAL	FINISH . REMARKS	NO.	MATERIAL	FINISH . REMARKS			
UNITS	mm	SCALE	10 : 1	COUNT	DESCRIPTION OF REVISIONS	DESIGNED	CHECKED	DATE
HRS		HIROSE ELECTRIC CO., LTD.	APPROVED : MO. ISHIDA	17.03.23	DRAWING NO.	EDC-334868-58-01		
			CHECKED : TS. MIYAZAKI	17.03.23	PART NO.	DF40B-12DS-0.4V(58)		
			DESIGNED : SH. HOSODA	17.03.23	CODE NO.	CL684-4152-3-58		
			DRAWN : RN. IIDA	17.03.23		1/2		

Sep.1.2020 Copyright 2020 HIROSE ELECTRIC CO., LTD. All Rights Reserved.  
 In case of consideration for using Automotive equipment / device which demand high reliability, kindly contact our sales window correspondents.

EMBOSED CARRIER TAPE PACKAGING (FREE)

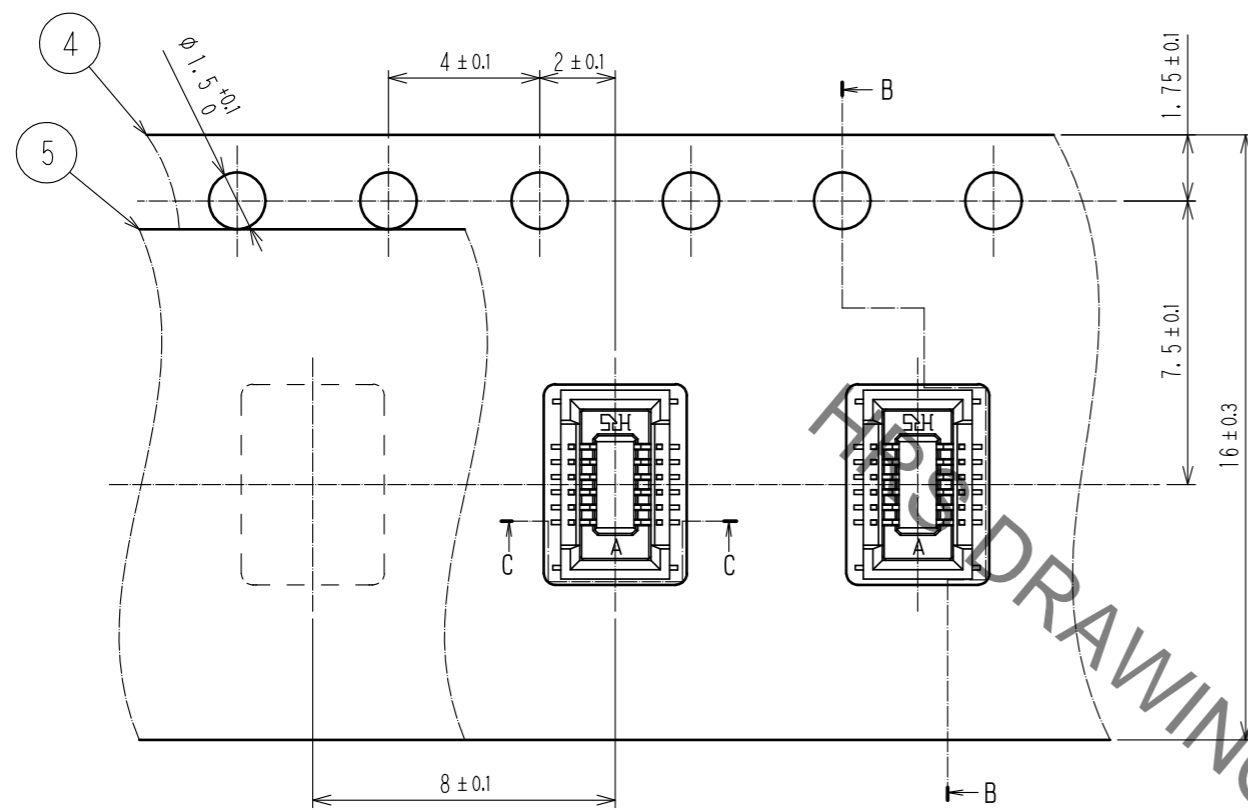

DIRECTION OF UNREELING →

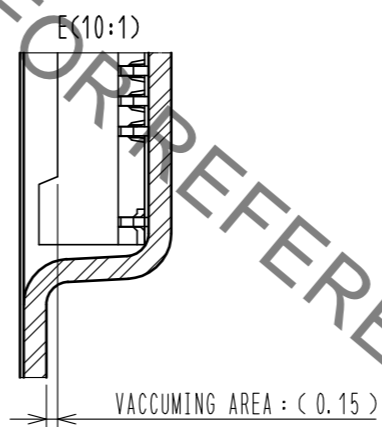
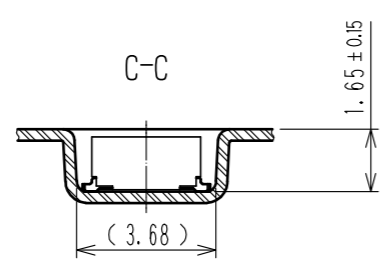

STYLE AND DIMENSION OF REEL (FREE SIZE)

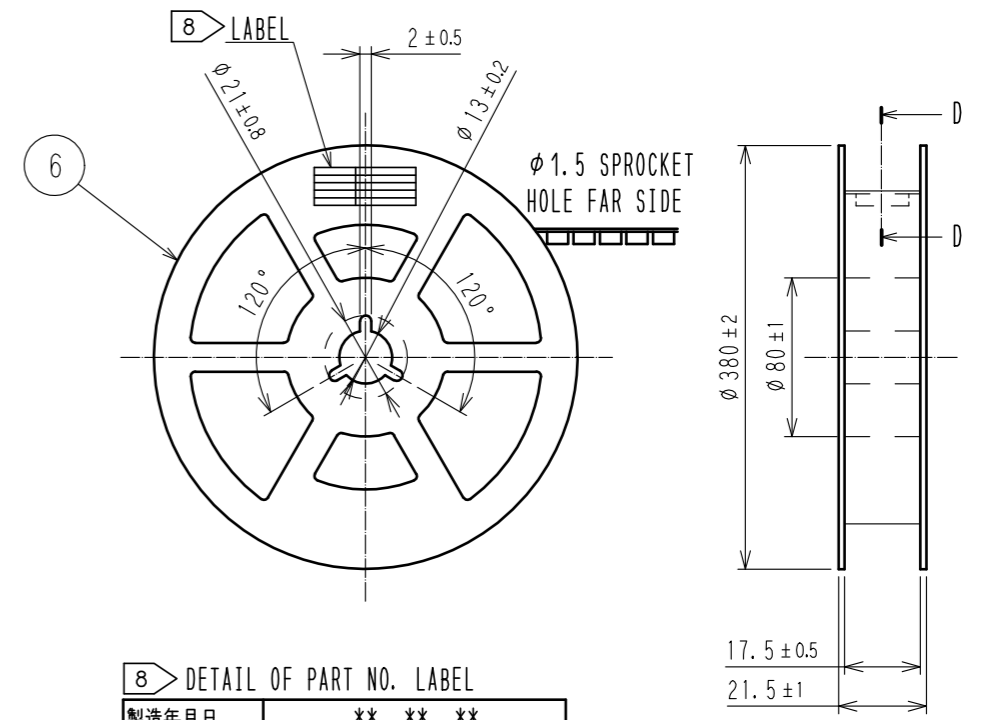

8 DETAIL OF PART NO. LABEL

製造年月日	** ** *
製品コード	CL684-4152-3-58
製品名	DF40B-12DS-0.4V(58)
数量	1000
納入者	ヒロセ電機(株)

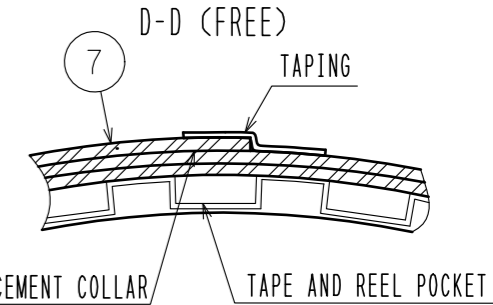

- NOTES)
- 5. PER REEL 1000 CONNECTORS.
  - 6. THE DIMENSIONS IN PARENTHESES ARE FOR REFERENCE.
  - 7. REFER TO JIS C 0806. IEC 60286-3(PACKING OF COMPONENTS FOR AUTOMATIC HANDLING)
  - 8. DETAIL OF PART NO. LABEL IS WRITTEN IN JAPANESE.  
 PRODUCTION DATE:  
 PRODUCT CODE: CL684-4152-3-58  
 PART NUMBER: DF40B-12DS-0.4V(58)  
 NUMBER OF PIECES: 1000 PIECES  
 SUPPLIER NAME: HIROSE ELECTRIC CO., LTD.
  - 9. THE POCKET SHAPE IS DIFFERENT AT INTERVALS OF FOUR POCKETS TO AVOID OVERLAP.
  - 10. AFTER PACKAGING, ROLL 2 METERS OF THE REINFORCEMENT COLLAR TO OUTER CIRCUMFERENCE OF TAPE AND REEL POCKET. AND TAPE DOWN AT THE END THE COLLAR.

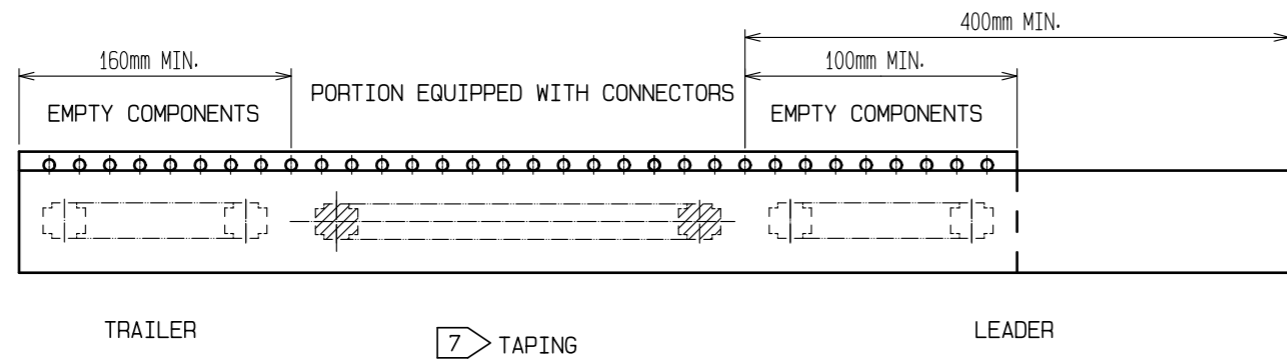

<b>HRS</b>	DRAWING NO.	EDC-334868-58-01
	PART NO.	DF40B-12DS-0.4V(58)
	CODE NO.	CL684-4152-3-58
		△ 2/2