

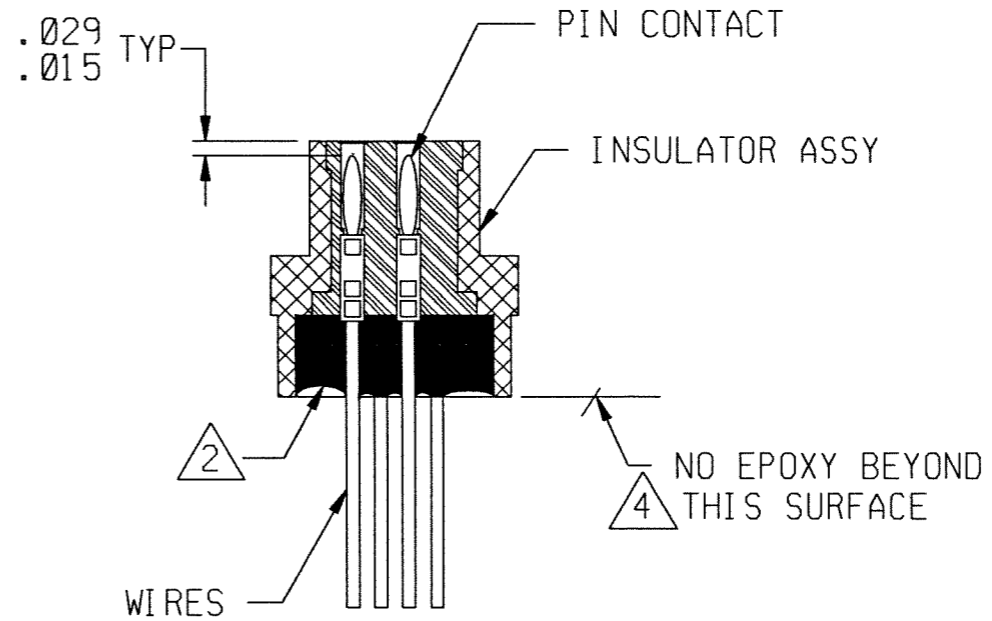

REVISION					
ZONE	LTR	ECN	DESCRIPTION	DATE	APPROVED
	C	38898	UPDATE MKING & EPOXY NOTES	4/29/99	<i>[Signature]</i>

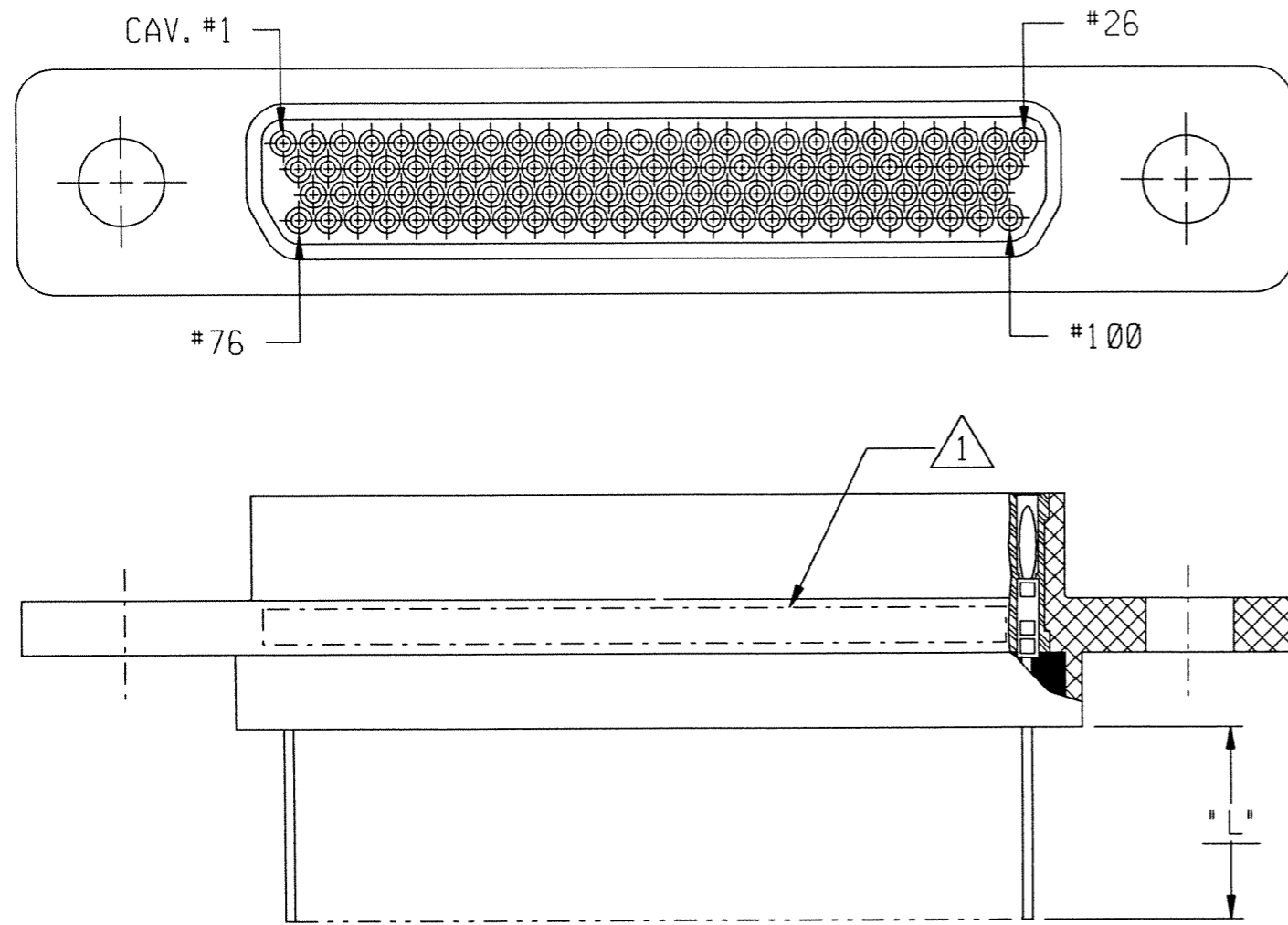

NOTES: UNLESS OTHERWISE SPECIFIED.

- 1 MARK PER TIS.
- 2 EPOXY AS SHOWN USING 194-8102-6215/6225.
- 3. CRIMP LEADS INTO CONTACTS PER MEP302-05.
- 4 EPOXY WICKING: UNINSULATED WIRE: .050 MAX.
INSULATED WIRE UPTO #25 AWG: .125 MAX.
INSULATED WIRE #24 AWG OR LARGER: .200 MAX.

Tyco Dwg 7-1532141-5
Micro P/N 094-0000-0014

UNLESS OTHERWISE SPECIFIED DIMENSIONS ARE IN INCHES. TOLERANCE ARE:			APPROVALS		 MICRODOT CONNECTORS A DIVISION OF UNI-STAR INDUSTRIES INC. 306 PASADENA AVE., SO. PASADENA, CA 91030
FRACTIONS	DECIMALS	ANGLES	SIGNATURE	DATE	
± 1/8	.XX ± .01 .XXX ± .005	± 2°	<i>J. CHU</i>	4/28/99	METAL "D" CONNECTOR MCK-XX-XX-100P-X MCK 100 PLUG MASTER
MATERIAL:			P. E.		
FINISH:			D. A.		CODE M
<small>THIS DOCUMENT IS THE PROPERTY OF MICRODOT CONNECTORS, A DIVISION OF UNI-STAR INDUSTRIES INC. USE OF THIS DOCUMENT OR ANY PART THEREOF IS STRICTLY FORBIDDEN WITHOUT THE EXPRESS WRITTEN PERMISSION OF MICRODOT CONNECTORS, A DIVISION OF UNI-STAR INDUSTRIES INC.</small>			SIZE B	CODE IDENT NO. 98278	DRAWING NO. 094-0000-0014
			SCALE: NONE		SHEET 1 OF 1