

1) Sensing surface, 2) Housing, 3) Cover, 4) Power indicator green, 5) Function indicator yellow



Basic features

Additional features	Electrically conductive media Foam and residue compensation
Approval/Conformity	CE cULus WEEE
Basic standard	IEC 60947-5-2
Scope of delivery	Holder Installation guide
Sensitivity	teachable depending on media
Series	R08

Display/Operation

Function indicator	yes
Power indicator	yes
Setting	Teachable

Electrical connection

Cable diameter D	3.4 mm
Cable length L	2 m
Conductor cross-section	0.14 mm ²
Number of conductors	4
Polarity reversal protected	yes
Protection against device mix-ups	yes
Short-circuit protection	yes

Electrical data

Load capacitance max. at Ue	0.33 µF
No-load current I_o max. at Ue	12 mA
Operating voltage U_b	12...30 VDC
Rated insulation voltage U_i	75 V DC
Rated operating current I_e	50 mA
Rated operating voltage U_e DC	24 V
Ready delay t_v max.	200 ms
Residual current I_r max.	10 µA
Ripple max. (% of U_e)	10 %
Switching frequency	10 Hz
Utilization category	DC -13
Voltage drop static max.	1.5 V

Environmental conditions

Ambient temperature	-25...70 °C
Contamination scale	3
Protection degree	IP67
Storage temperature	-25...85 °C

Functional safety

MTTF (40 °C)	98 a
---------------------	------

Material

Cover material	PP
Housing material	PP
Material jacket	PUR
Material sensing surface	PP

Capacitive Sensors
BCS R08RRE-PSMFHC-EP02
Order Code: BCS012H

BALLUFF

Mechanical data

Dimension	34 x 16 x 8 mm
Installation	flush with container outer wall
Size	Block style

Tightening torque

0.2 Nm

Output/Interface

Switching output

PNP normally open (NO)

Remarks

Note for using in standard applications with aqueous media: The Smart Level sensors are factory adjusted for standard applications. With this setting the Smart Level sensors can be used without further adjustment for detecting aqueous media through glass or plastic walls. The factory setting can automatically mask glass or plastic walls (approx. 0.5 mm to 6 mm) and compensate for foam, moisture and dirt buildup inside and outside the container. Special applications: The Smart Level sensors can also be used with aqueous media in previously unsolvable and critical applications such as through glass or plastic walls thicker than 6 mm. Here the user can change the factory setting.

For full calibration connect input DI to L+ for 2...7 seconds. For empty calibration connect to L+ for 7..12 seconds.

Input DI can be used for teaching the switching point. In normal operation input DI should be connected continuously to L-.

For more information about MTTF and B10d see MTTF / B10d Certificate

Indication of the MTTF- / B10d value does not represent a binding composition and/or life expectancy assurance; these are simply experiential values with no warranty implications. These declared values also do not extend the expiration period for defect claims or affect it in any way.

Wiring Diagrams

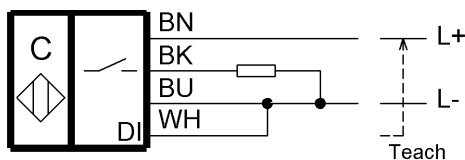

Help Views

Zubehör - Halter
 Accessories - Mounting frame

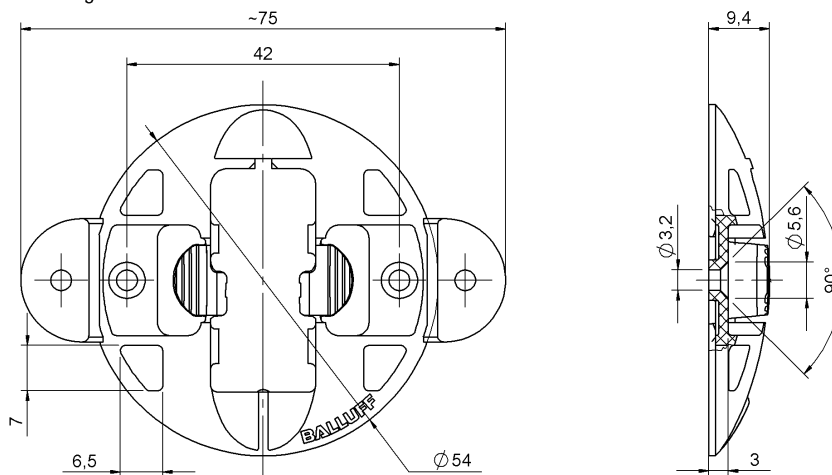

Werkstoff Halter: PP
 Material mounting frame: PP