

Basic features

Application	Pneumatic cylinder, round without groove or tie rod Piston diameter 8 - 63 mm
Basic standard	Dimension tolerances: DIN ISO 2768 m
Principle of operation	BMF mounting bracket
Scope of delivery	Fastening part Mounting bracket
Use	for magnetic sensors BMF 10E

Environmental conditions

Ambient temperature	-40...85 °C
----------------------------	-------------

Remarks

Order tube cuff separately. Order example: Tube cuff BMF size 3
 Tube cuff size 2 - piston rod Ø8, Ø10, Ø12
 Tube cuff size 3 - piston rod Ø16, Ø20, Ø25
 Tube cuff size 4 - piston rod Ø32
 Tube cuff size 5 - piston rod Ø40
 Tube cuff size 6 - piston rod Ø50
 Tube cuff size 8 - piston rod Ø63

Material

Material	Stainless steel (1.4305)
-----------------	--------------------------

Mechanical data

Mounting, holder	Hose clamp made of stainless steel 1.4301
Sensor attachment	Cylinder head screw ISO 1207 M3x6-A2 hex nut ISO 4035-M3-A2
Tightening torque	1.5 Nm
Tightening torque clamping screw	1.2 Nm

Help Views

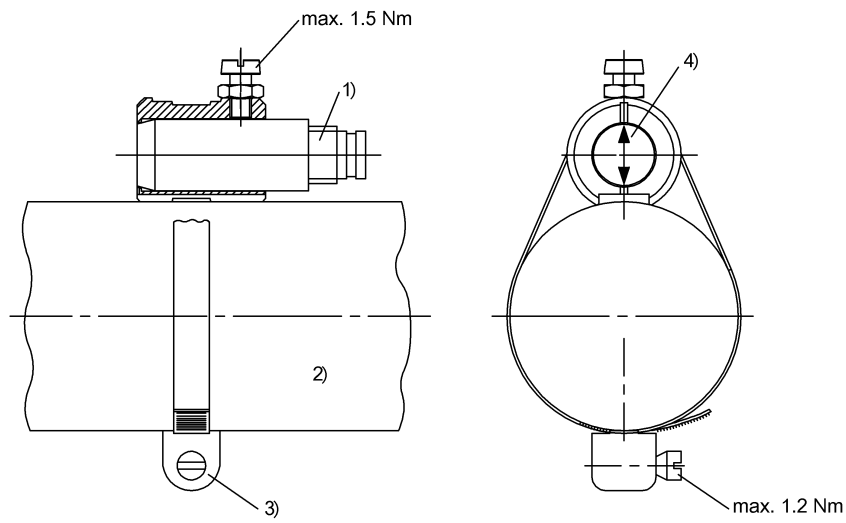

- 1) BMF 10E...
- 2) Cylinder
- 3) BMF tube cuff
- 4) Align arrows with slot