

THIS DRAWING IS UNPUBLISHED. RELEASED FOR PUBLICATION 20  
 © COPYRIGHT 20 BY TYCO ELECTRONICS CORPORATION. ALL RIGHTS RESERVED.

LOC	DIST	REVISIONS					
HM	00	P	LTR	DESCRIPTION	DATE	DWN	APVD
		F		ECO-06-026326	11JAN2007	JM	NJ
		G		REV ECO-07-029214	12MAR2008	LH	NJ
		H		REV; ECO-08-013420	30MAY2008	GG	NJ

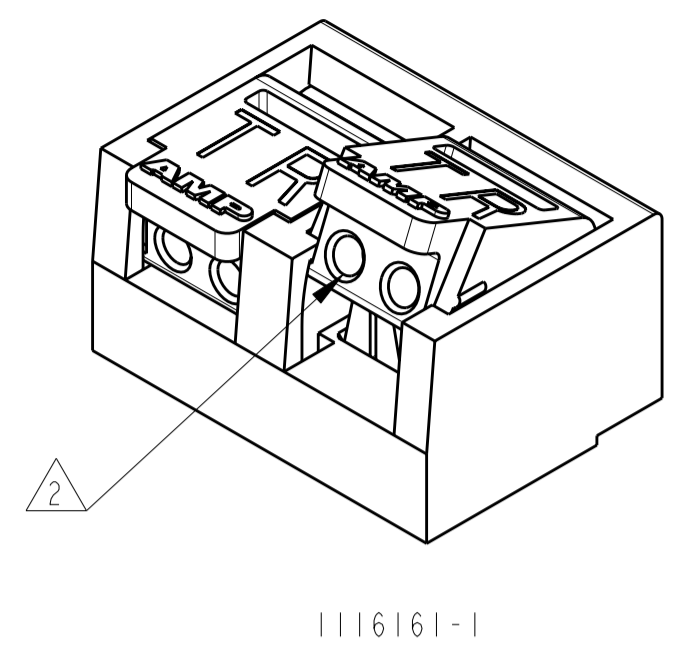

- 1 MATERIAL: BASE - POLYESTER MOLDING COMPOUND, BLACK. WIRE STUFFER - POLYCARBONATE MOLDING COMPOUND, CLEAR. TERMINAL - COPPER ALLOY, 3.81um [.000150] MINIMUM THICK MATTE TIN OVER 1.27um [.000050] MINIMUM THICK NICKEL UNDERPLATE.
- 2 EACH WIRE ENTRY HOLE ACCEPTS ONE UNSTRIPPED SOLID COPPER 22-24 AWG WIRE WITH A WIRE INSULATION DIAMETER RANGE FROM 1.52 [.060] THROUGH 1.02 [.040]. OTHER WIRE SIZES AND TYPES SHALL BE SUBMITTED TO AMP ENGINEERS FOR APPLICATION APPROVAL.
- 3. SOLDER TABS PROVIDED FOR PERMANENT BOARD MOUNTING.
- 4 FOR GREASE FILLED PRODUCT, GREASE MUST COVER FRONT OF IDC WHEN PIVOT IS IN MAXIMUM OPEN POSITION.

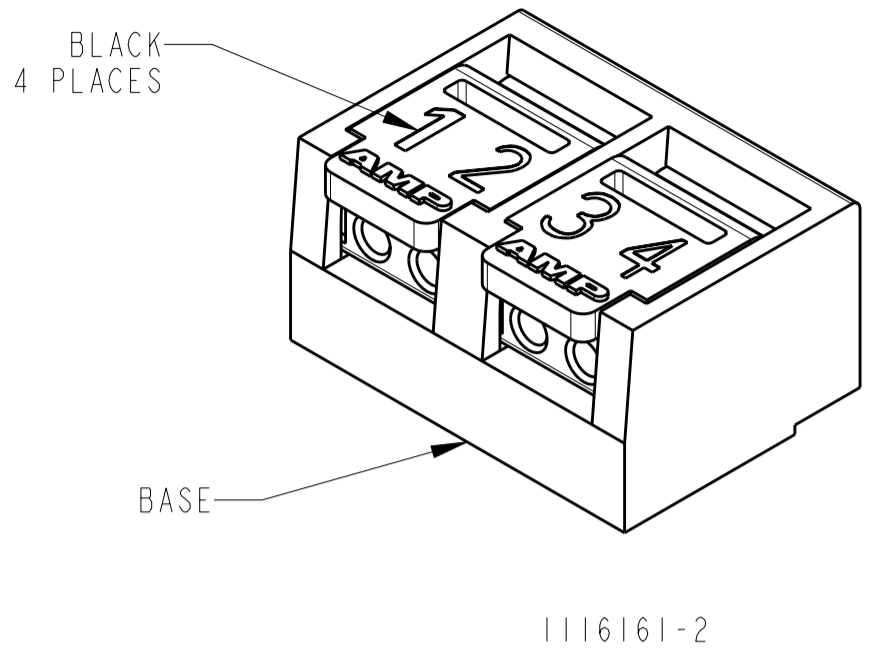
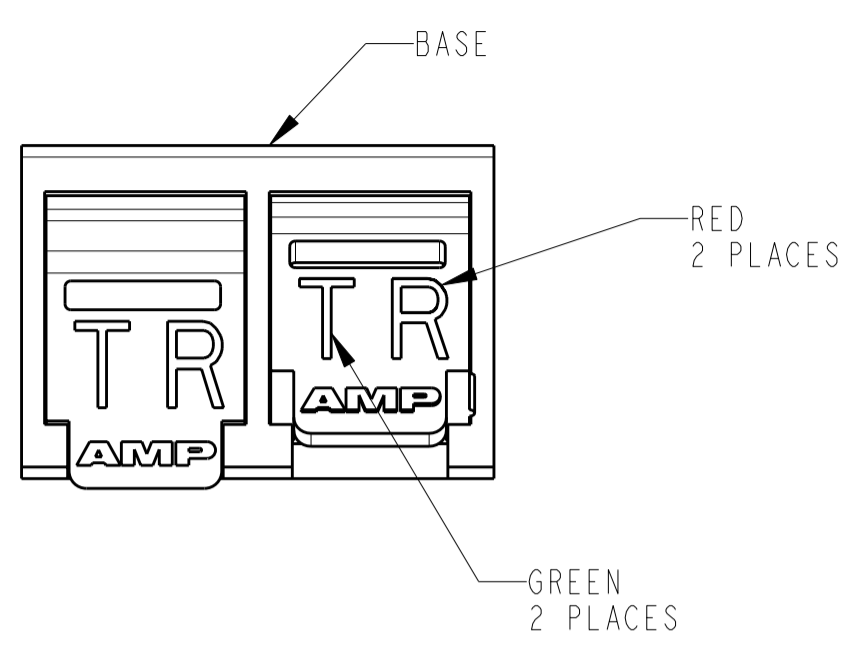
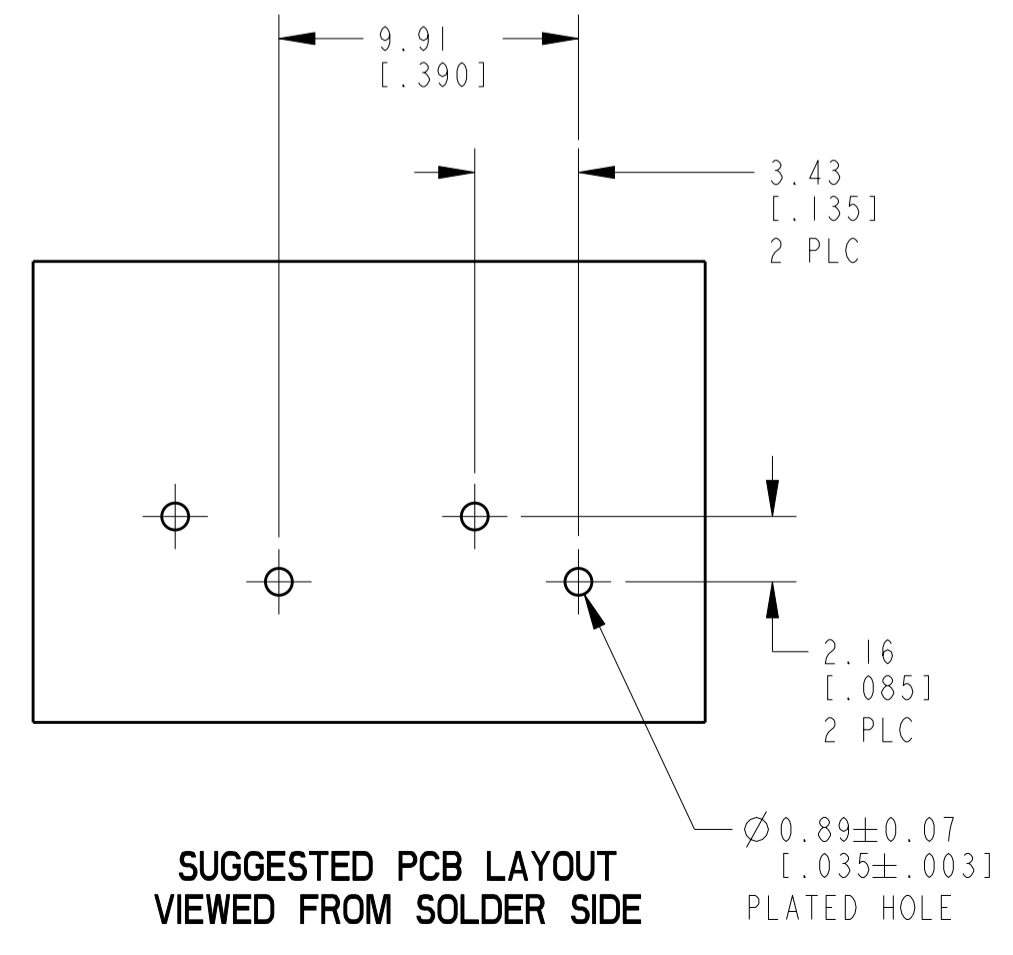
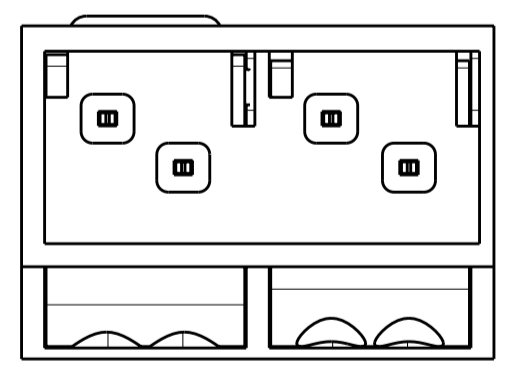
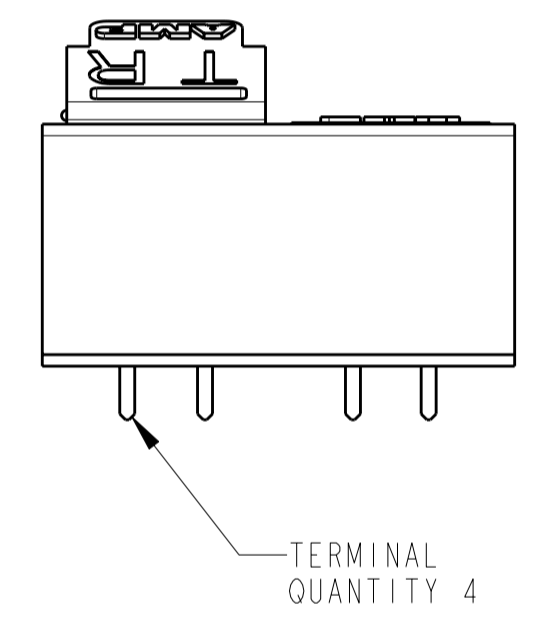
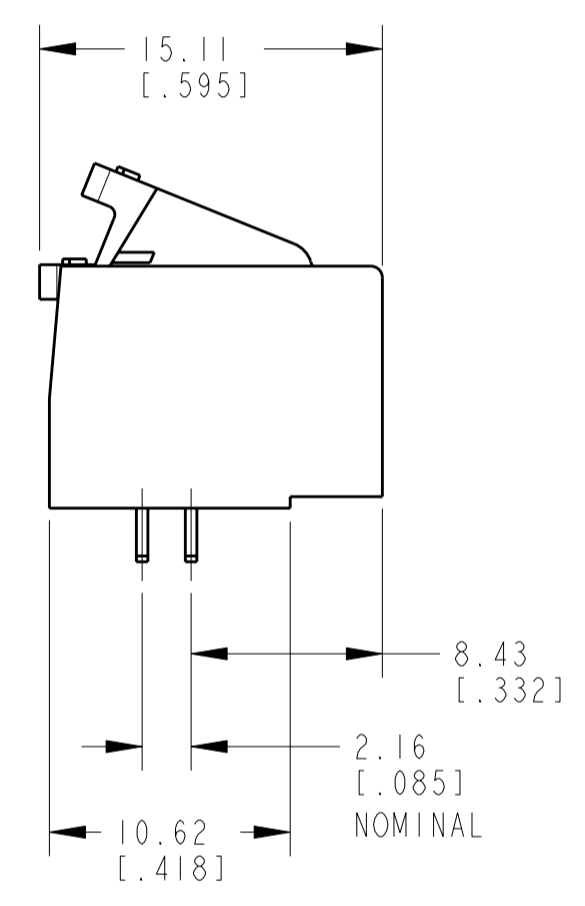
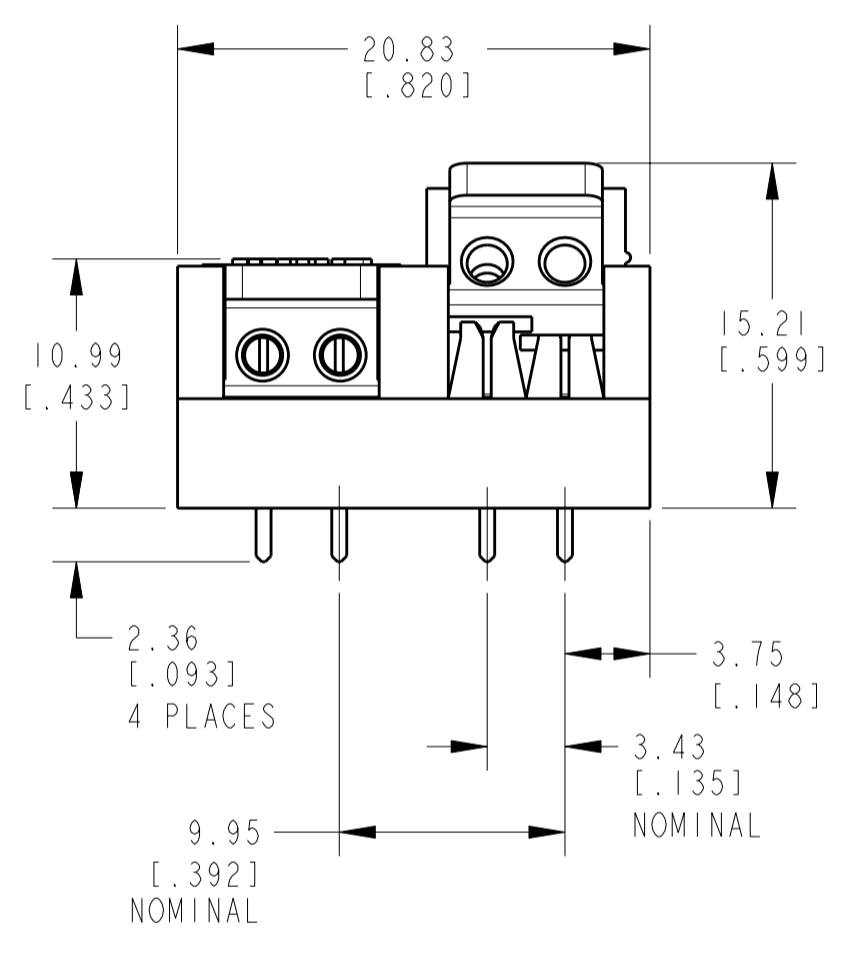

DESCRIPTION	PART NUMBER
PIVOT CONNECTOR ASSY, 1/4, LF	1116161-8
PIVOT CONNECTOR ASSY, T/R, LF	1116161-7
PIVOT CONNECTOR ASSY, 1/4, LF	1116161-6
PIVOT CONNECTOR ASSY, T/R, LF	1116161-5
PIVOT CONNECTOR ASSY, 1/4	1116161-4
PIVOT CONNECTOR ASSY, T/R	1116161-3
PIVOT CONNECTOR ASSY, 1/4	1116161-2
PIVOT CONNECTOR ASSY, T/R	1116161-1

THIS DRAWING IS A CONTROLLED DOCUMENT FOR TYCO ELECTRONICS CORPORATION. IT IS SUBJECT TO CHANGE AND THE CONTROLLING ENGINEERING ORGANIZATION SHOULD BE CONTACTED FOR THE LATEST REVISION.		DWN T. WOITEN 08APR08 CHK T. WOJTACKI 15APR08 APVD T. WOJTACKI 15APR08	Tyco Electronics Harrisburg, PA 17105-3608
DIMENSIONS: mm [INCHES]	TOLERANCES UNLESS OTHERWISE SPECIFIED: 0 PLC ± 1 PLC ± 2 PLC ±0.25 [.010] 3 PLC ±0.13 [.005] 4 PLC ± ANGLES ° ±	PRODUCT SPEC 108-1657 APPLICATION SPEC 114-6062 WEIGHT .131 oz.	NAME PIVOT CONNECTOR ASSEMBLY, 2 PAIR, SINGLE ENTRY SIZE CAGE CODE DRAWING NO RESTRICTED TO A2 00779 C-1116161
MATERIAL 1 - 1		CUSTOMER DRAWING	SCALE 3:1 SHEET 1 OF 1 REV H