

1. INTRODUCTION

This instruction sheet provides terminating procedures for the 6- and 8-Position Commercial Keystone Jack Kits shown in Figures 1 and 7.

NOTE



Dimensions in this instruction sheet are in metric units [with U.S. customary units in brackets]. Figures are not drawn to scale.

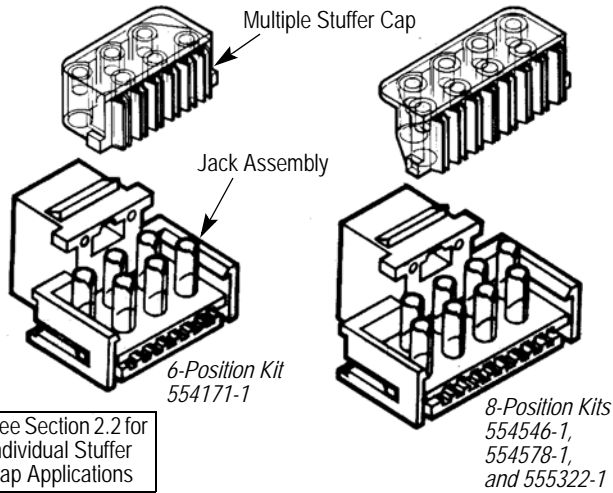

Figure 1

2. TERMINATING PROCEDURES

2.1. Multiple Stuffer Cap Applications

1. Strip cable jacket and trim wires to dimensions shown in Figure 2. Place end of each wire against back of slot and press all wires down into slots.

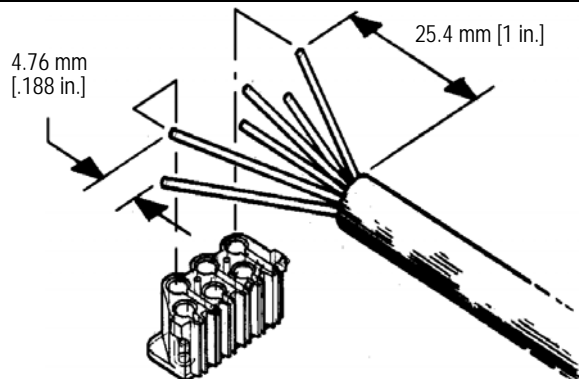

Figure 2

2. Inspect cap to ensure that each wire is in desired slot and that wire end is touching back of slot (Figure 3).

NOTE



A 6-position jack assembly is shown, same procedures apply for 8-position jack assembly.

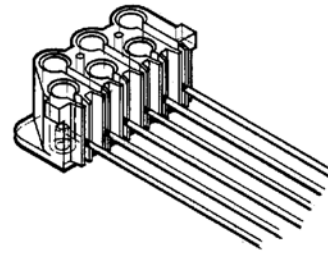

Figure 3

3. Position holes in cap over terminals in jack assembly (Figure 4).

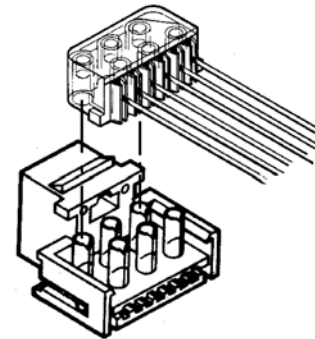

Figure 4

4. Using slip-joint pliers, terminate wires by pressing stuffer cap down over terminals until latches on cap engage jack assembly (Figure 5).

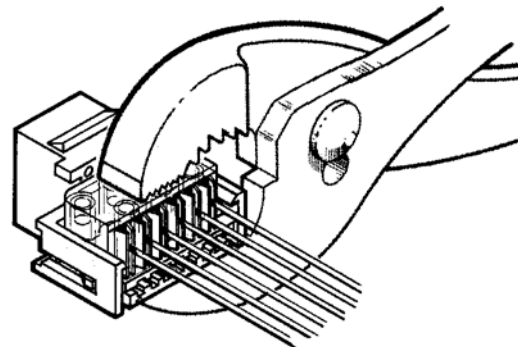

Figure 5

5. Inspect jack assembly to ensure that cap is fully seated and all wires are terminated (Figure 6).

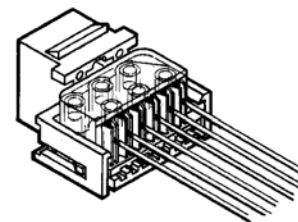
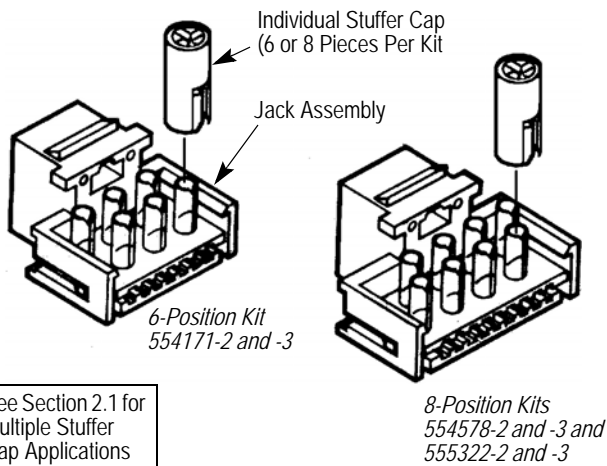

Figure 6



See Section 2.1 for Multiple Stuffer Cap Applications

Figure 7

2.2. Individual Stuffer Cap Applications

1. Strip cable jacket and trim wires to dimensions shown in Figure 8.

NOTE *A 6-position jack assembly is shown, same procedures apply for 8-position jack assembly.*

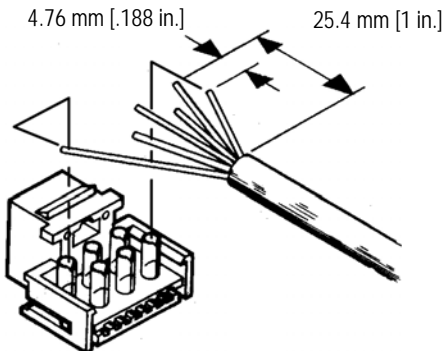

Figure 8

2. Hold wire in "V" at top of terminal with wire end touching inside back of terminal. Orient slot in stuffer cap above wire and slide cap down over terminal and wire. Terminate wire by pushing cap straight down with a No. 1 phillips screwdriver until cap is fully seated on terminal (Figure 9).

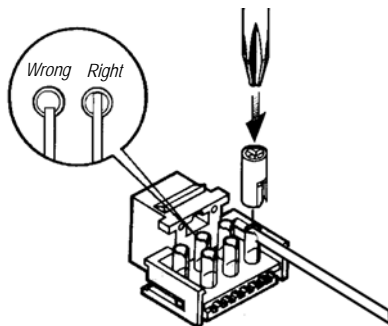

Figure 9

3. Terminate each wire by repeating Step 2. Inspect jack assembly to ensure that caps are fully seated and all wires are terminated (Figure 10).

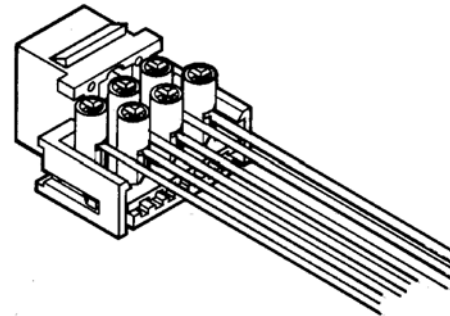

Figure 10

2.3. Undercarpet Applications

NOTE *For undercarpet applications, use 6-Position Kit 554171-2 or 8-Position Kit 554578-2.*

Strip cable jacket to dimension shown in Figure 11. Make crossovers as indicated. Terminate each wire as shown in Figure 9.

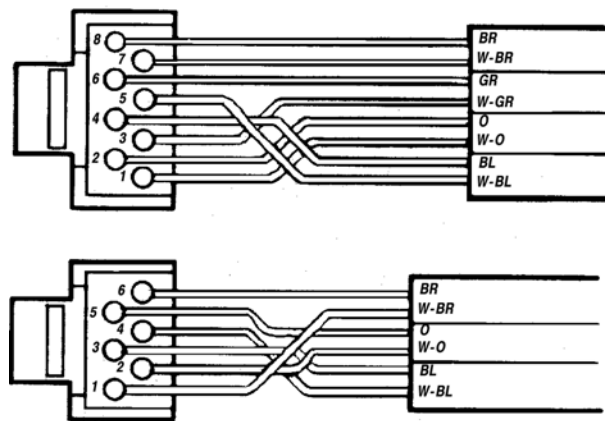
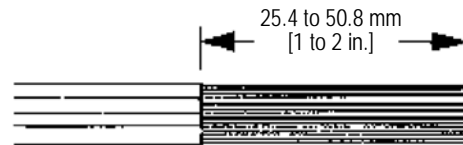

Figure 11

3. REVISION SUMMARY

Since the previous version of this document, the following changes were made:

- Added part number to Figure 1.
- Updated document to corporate requirements.