

Jun.1.2021 Copyright 2021 HIROSE ELECTRIC CO., LTD. All Rights Reserved.
 In case of consideration for using Automotive equipment / device which demand high reliability, kindly contact our sales window correspondents.

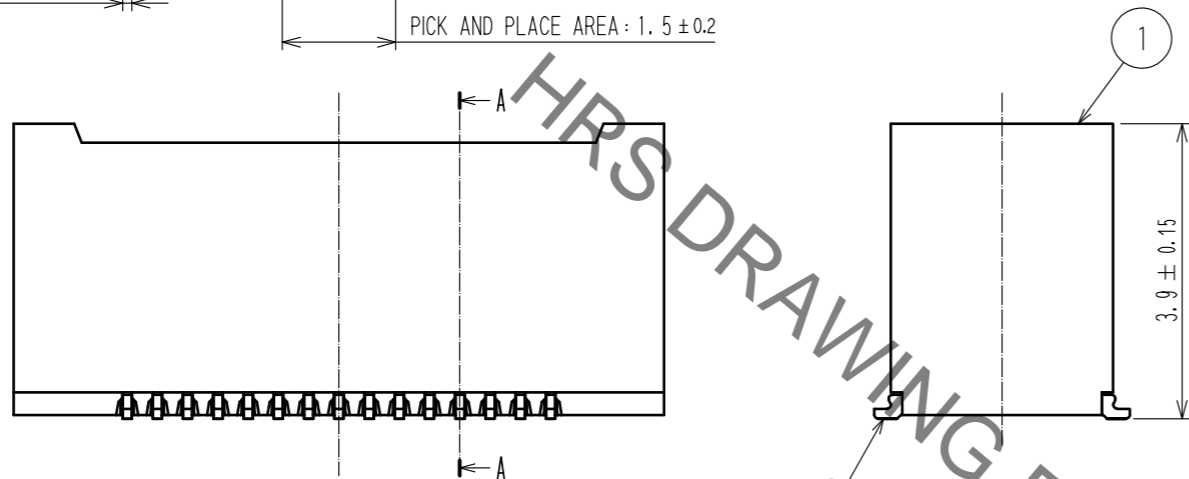

RECOMMENDED PATTERN

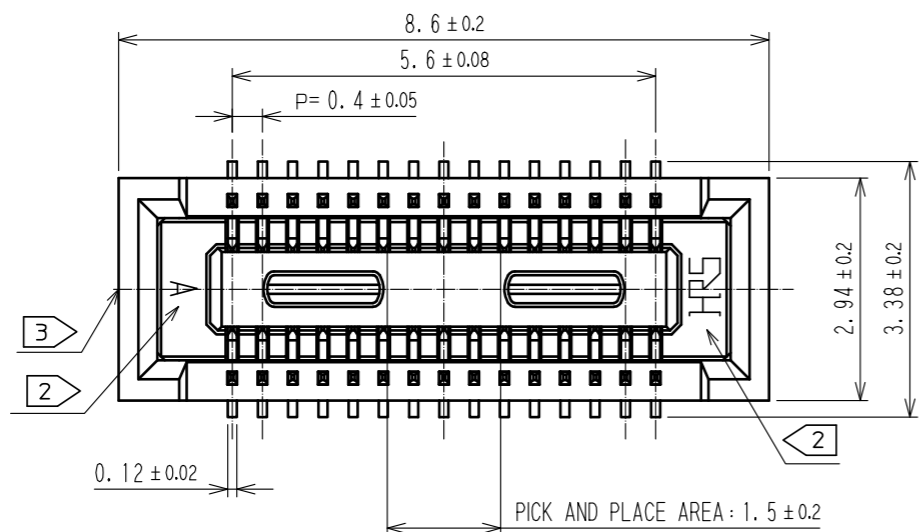
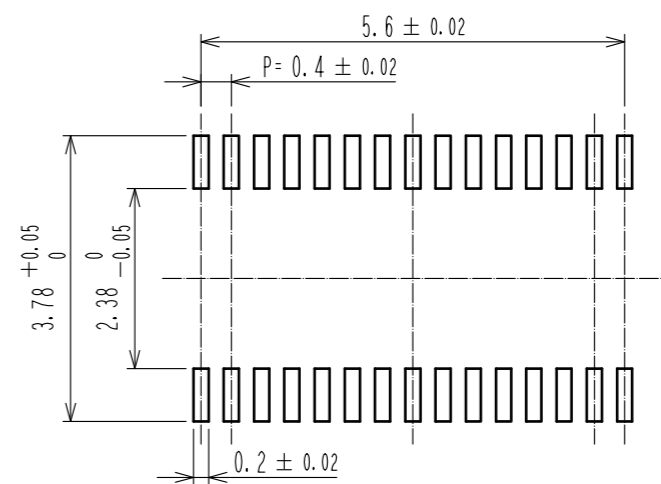

RECOMMENDED METAL MASK THICKNESS : 120 μm
 RECOMMENDED METAL MASK OPENING RATIO : 80% FOR LEAD PAD

A-A(20:1)
 PICK AND PLACE AREA : 0.99 ± 0.1

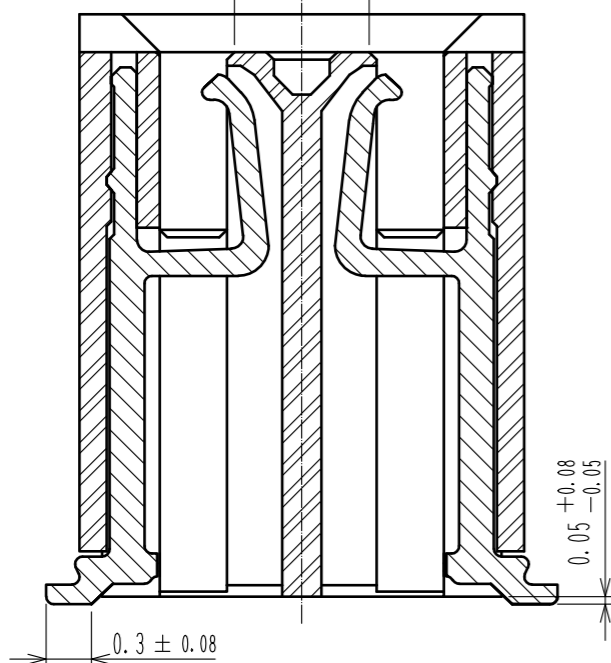

ENGAGEMENT FIGURE (20:1)

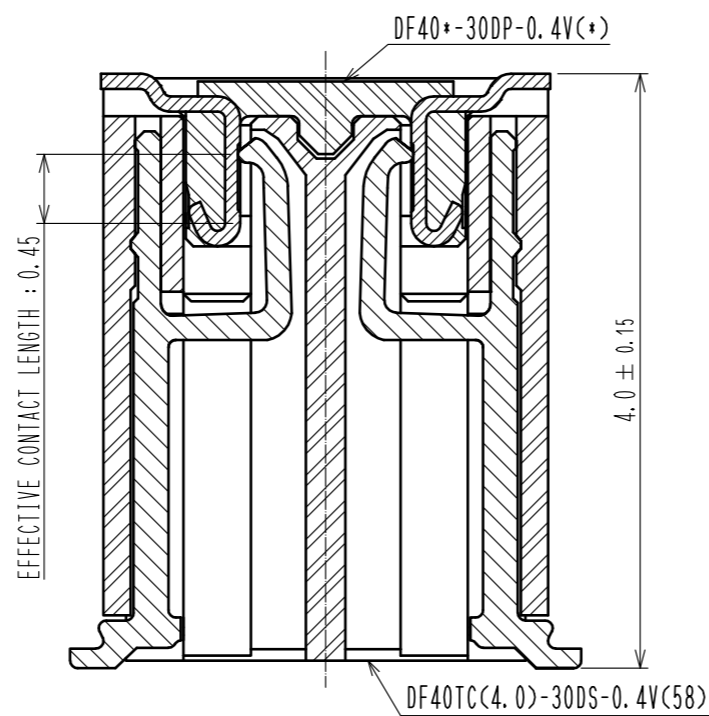

- NOTES) 1. ALL LEADS CO-PLANARITY SHALL BE 0.1 MAX.
 2. HRS MARK AND CAV NO. ARE LOCATED IN APPROXIMAL AREA.
 3. GATE IS COCATED IN APPROXIMAL AREA.

2	COPPER ALLOY	CONTACT AREA:GOLD 0.05 μm MIN SMT LEAD:GOLD 0.05 μm MIN UNDERPLATING:NICKEL 1 μm MIN	6	PS	CLEAR, REINFORCEMENT COLLAR		
			5	PS	BLACK		
			4	POLYESTER	CLEAR, COVER TAPE		
1	LCP	BLACK, UL94V-0	3	PS	CLEAR, EMBOSSED CARRIER TAPE		
NO.	MATERIAL	FINISH . REMARKS	NO.	MATERIAL	FINISH . REMARKS		
UNITS mm		SCALE 10:1	COUNT 0	DESCRIPTION OF REVISIONS	DESIGNED	CHECKED	DATE
APPROVED : WR. FUKUCHI 20210402			DRAWING NO. EDC-386149-58-00				
CHECED : TS. MIYAZAKI 20210402			PART NO. DF40TC(4.0)-30DS-0.4V(58)				
DESIGNED : YK. SATAKE 20210402			CODE NO. CL0684-4256-0-58				
DRAWN : YK. SATAKE 20210402			1/2				

Jun.1.2021 Copyright 2021 HIROSE ELECTRIC CO., LTD. All Rights Reserved.
In case of consideration for using Automotive equipment / device which demand high reliability, kindly contact our sales window correspondents.

EMBOSED CARRIER TAPE PACKAGING (FREE)

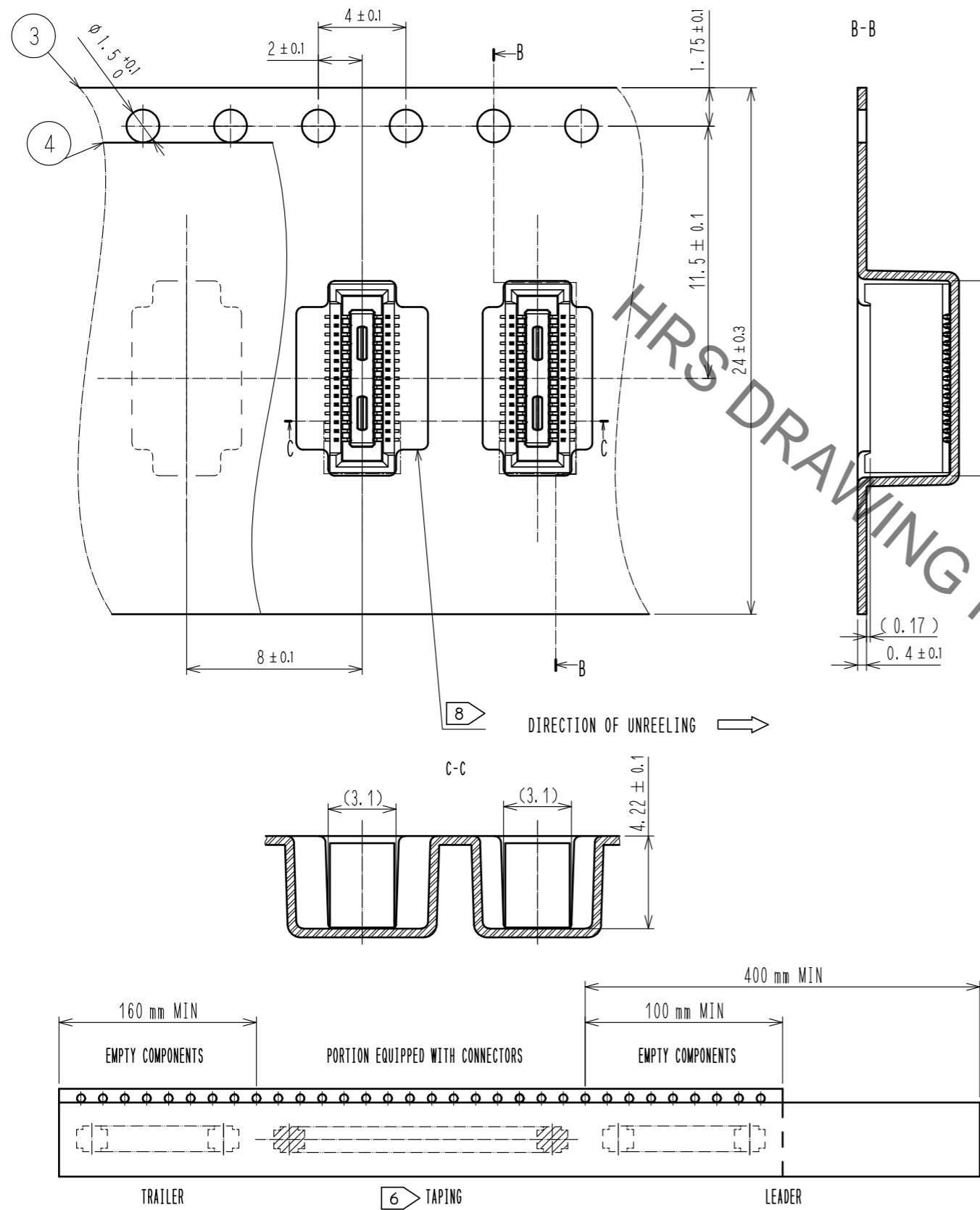

STYLE AND DIMENSION OF REEL (FREE)

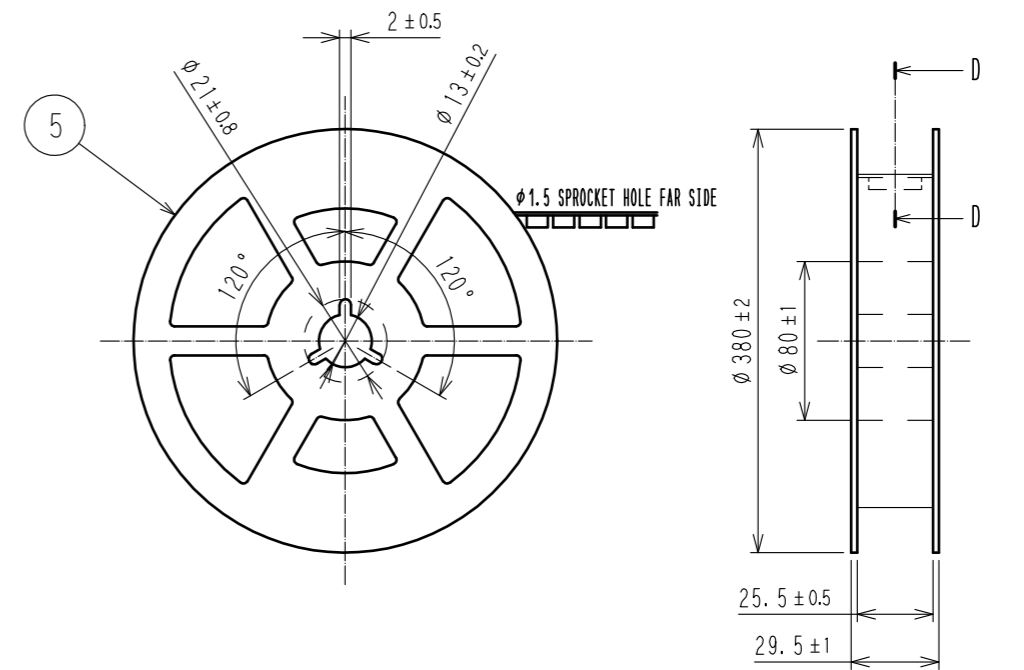

D-D (FREE)

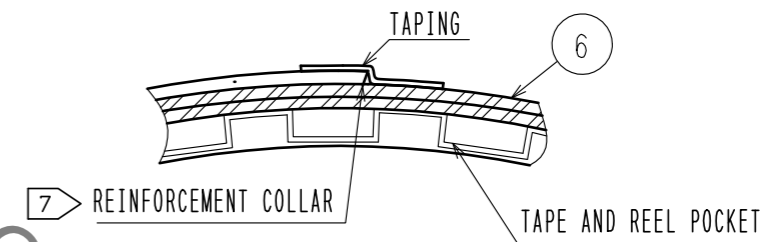

- NOTES**
- PER REEL 1000 CONNECTORS.
 - THE DIMENSIONS IN PARENTHESES ARE FOR REFERENCE.
 - REFER TO JIS C 0806 (IEC 60286-3) (PACKING OF COMPONENTS FOR AUTOMATIC HANDLING)
 - AFTER PACKAGING, ROLL 2 METERS OF THE REINFORCEMENT COLLAR TO OUTER CIRCUMFERENCE OF TAPE AND REEL POCKET, AND TAPE DOWN AT THE END THE COLLAR.
 - ONE OF SEVERAL IS DIFFERENT IN FROM OF THE EMBOSED CARRIER TAPE TO AVOID BEING STUCK IN.

HRS	DRAWING NO.	EDC-386149-58-00
	PART NO.	DF40TC(4.0)-30DS-0.4V(58)
	CODE NO.	CL0684-4256-0-58
		\triangle 2/2