

Jul.1.2021 Copyright 2021 HIROSE ELECTRIC CO., LTD. All Rights Reserved.
In case of consideration for using Automotive equipment / device which demand high reliability, kindly contact our sales window correspondents.

Contact No.1 marking

Recommended PCB layout
Recommended metal mask (thickness:0.1mm)

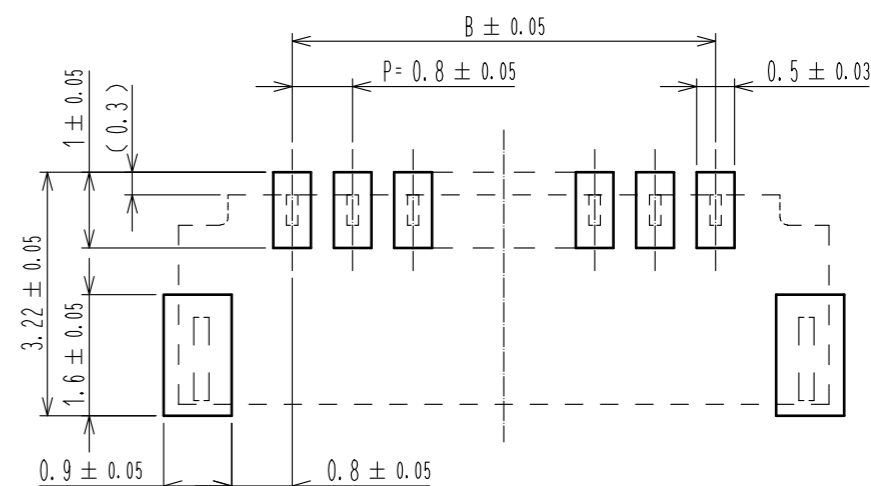
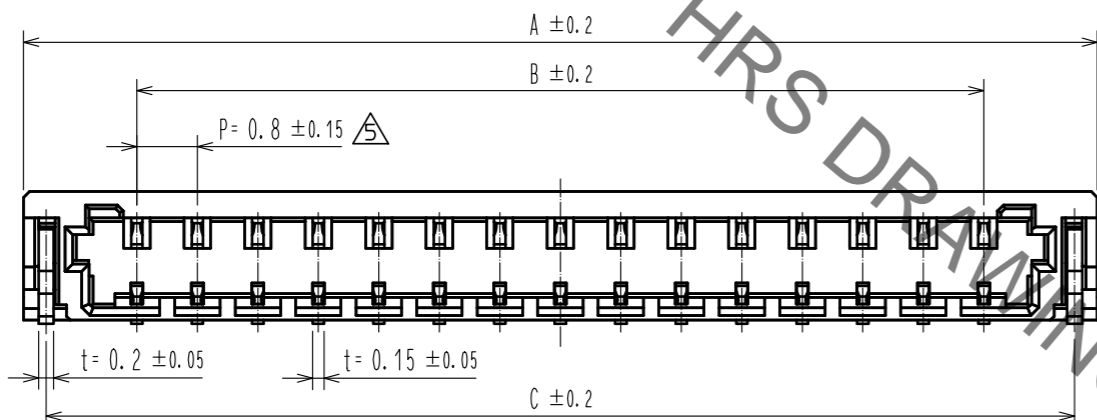

Mating Figure (Free)

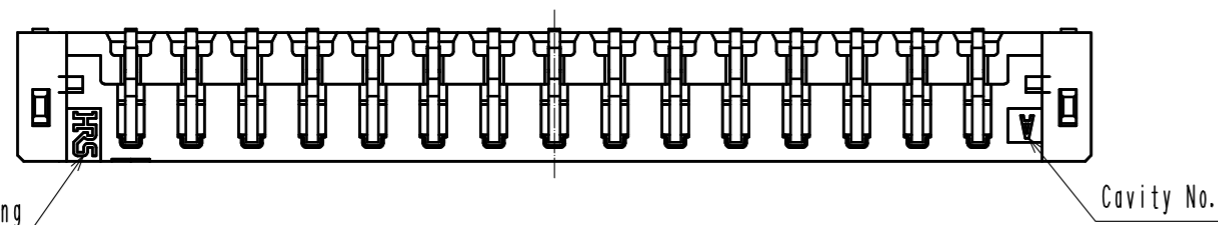
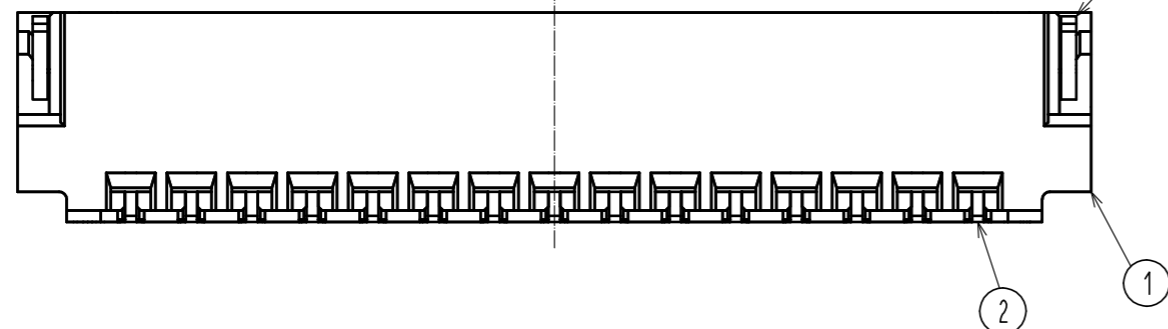
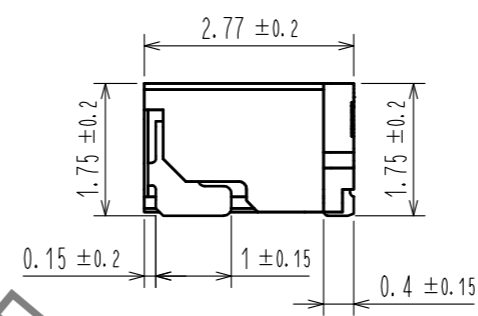
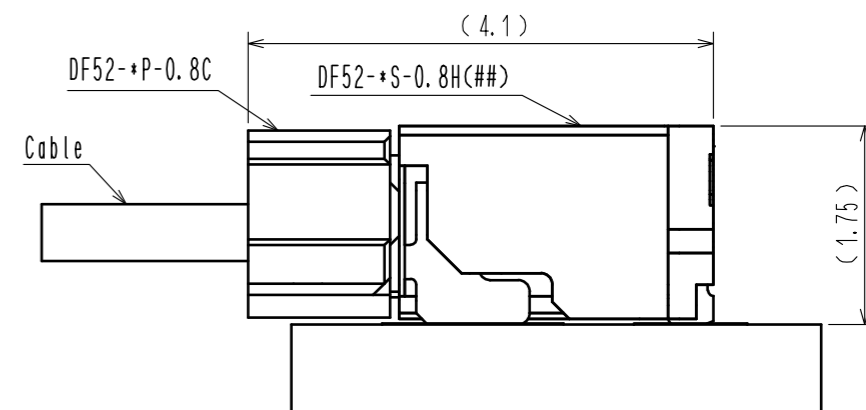

Part No.	Code No.	A	B	C
DF52-2S-0.8H(21)	CL0668-0004-5-21	3.8	0.8	3.2
DF52-3S-0.8H(21)	CL0668-0022-7-21	4.6	1.6	4.0
DF52-4S-0.8H(21)	CL0668-0005-8-21	5.4	2.4	4.8
DF52-5S-0.8H(21)	CL0668-0023-0-21	6.2	3.2	5.6
DF52-6S-0.8H(21)	CL0668-0006-0-21	7.0	4.0	6.4
DF52-8S-0.8H(21)	CL0668-0007-3-21	8.6	5.6	8.0
DF52-10S-0.8H(21)	CL0668-0008-6-21	10.2	7.2	9.6
DF52-12S-0.8H(21)	CL0668-0009-9-21	11.8	8.8	11.2
DF52-14S-0.8H(21)	CL0668-0024-2-21	13.4	10.4	12.8
DF52-15S-0.8H(21)	CL0668-0010-8-21	14.2	11.2	13.6
DF52-16S-0.8H(21)	CL0668-0025-5-21	15.0	12.0	14.4
DF52-17S-0.8H(21)	CL0668-0001-7-21	15.8	12.8	15.2
DF52-20S-0.8H(21)	CL0668-0011-0-21	18.2	15.2	17.6

3	Brass	Surface:tin plating 1μmMIN	6	PS	Black(Reel)
2	Copper alloy	Surface:tin plating 1μmMIN	5	Polyester	Clear(Cover tape), ANTI-STATIC
1	Polyamide	Black, UL94V-0	4	PS	Clear(Embossed carrier tape), ANTI-STATIC
NO.	MATERIAL	FINISH . REMARKS	NO.	MATERIAL	FINISH . REMARKS
UNITS	mm	SCALE	10:1	COUNT	2
DESCRIPTION OF REVISIONS			DESIGNED	CHKD	DATE
DIS-H-00003668			HK. HAYASHI	TS. FUKUSHIMA	18.03.22
APPROVED : KI. AKIYAMA 14.06.27			DRAWING NO. EDC3-356517-01		
CHECKED : HK. UMEHARA 14.06.27			PART NO. DF52-*S-0.8H(21)		
DESIGNED : TH. YOSHIZAWA 14.06.26			CODE NO. CL668-		
DRAWN : TH. YOSHIZAWA 14.06.26			1/2		

Note 1. Lead co-planarity shall be 0.1mm MAX.
2. Please consult HIROSE when the product is mounted to FPC.

Jul.1.2021 Copyright 2021 HIROSE ELECTRIC CO., LTD. All Rights Reserved.
In case of consideration for using Automotive equipment / device which demand high reliability, kindly contact our sales window correspondents.

Drawing for packing (Free)

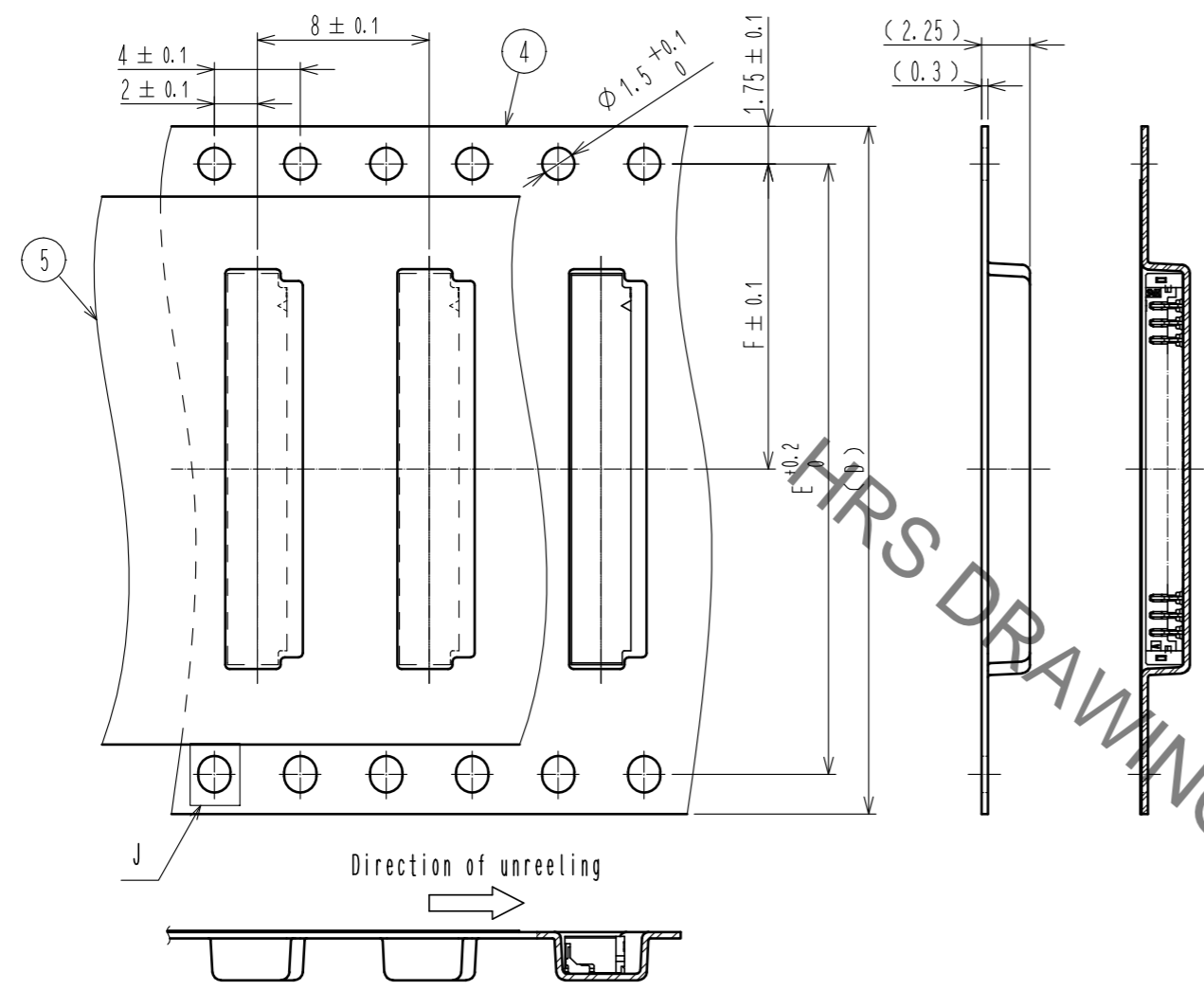

Style and dimension of reel (Free)

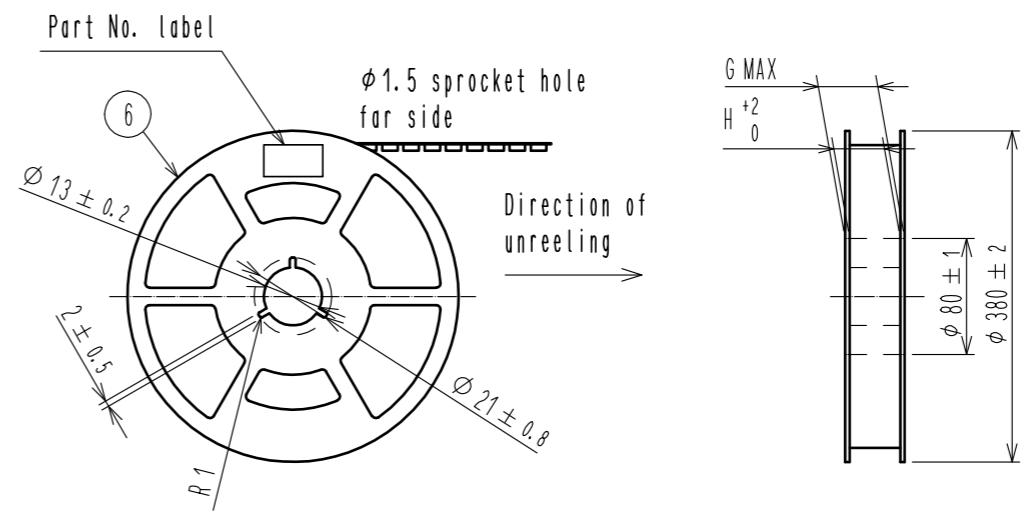

Detail of part No. label

Lot No.	170 7010	◀ 7
CL Code	CL668-0001-7-21	
品名 (Part Number)	DF52-17S-0.8H(21)	
納入数量 (Qty)	5000 K0	
ヒロセ電機(株)		

Direction of unreeling



Taping (Free)

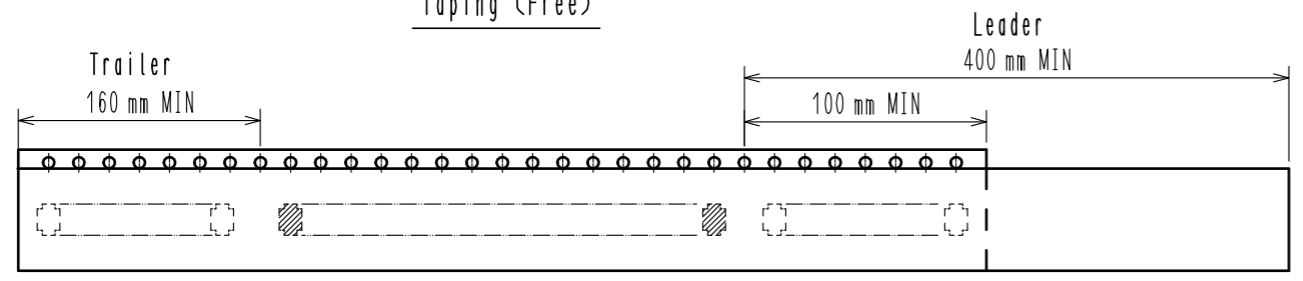

Empty components Portion equipped connectors Empty components

Reflow temperature profile using lead-free solder paste (Reference)

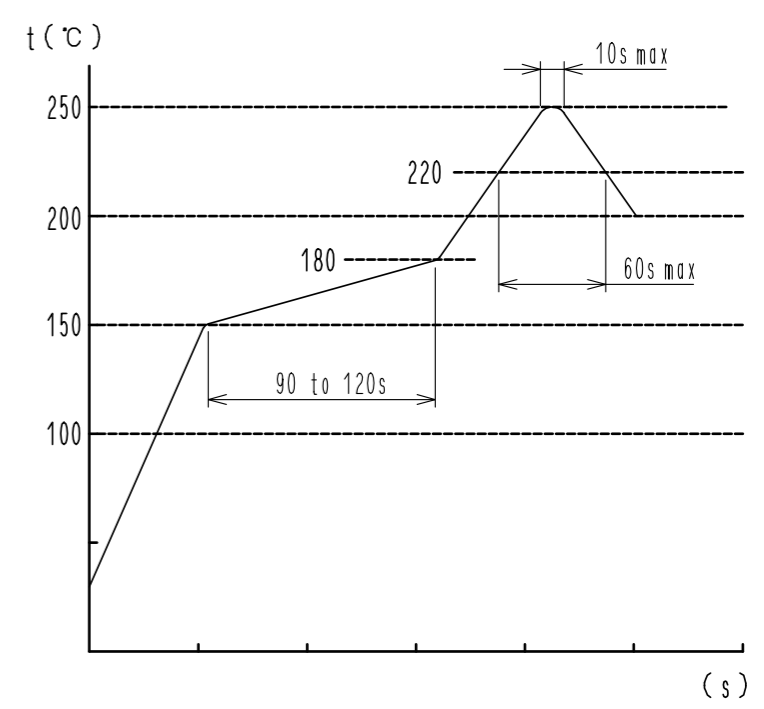

Number of reflow cycles 2 cycles MAX.
The temperature is measured in the terminal lead part.

Additional factors, such as solder paste type, PCB size and other mounted components could affect the profile, therefore, a thorough evaluation of mounting condition is required prior to production.

- Note
- 3. 1reel:5000 connectors.
 - 4. () is reference dimension.
 - 5 When the tape width is 32mm, sprocket holes shall be set on both side of reel as shown on this drawing.
 - 6 Refer to JIS C 0806. (Packaging of components for automating handling)
 - 7 Each meaning of Lot No. are shown below.

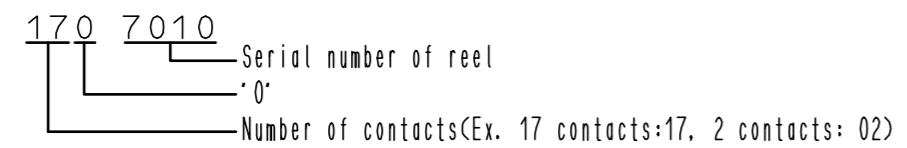

Part No.	Code No.	D	E	F	G	H
DF52-2S-0.8H(21)	CL0668-0004-5-21	16.0	/	7.5	22.4	16.4
DF52-3S-0.8H(21)	CL0668-0022-7-21	16.0	/	7.5	22.4	16.4
DF52-4S-0.8H(21)	CL0668-0005-8-21	16.0	/	7.5	22.4	16.4
DF52-5S-0.8H(21)	CL0668-0023-0-21	16.0	/	7.5	22.4	16.4
DF52-6S-0.8H(21)	CL0668-0006-0-21	16.0	/	7.5	22.4	16.4
DF52-8S-0.8H(21)	CL0668-0007-3-21	24.0	/	11.5	30.4	24.4
DF52-10S-0.8H(21)	CL0668-0008-6-21	24.0	/	11.5	30.4	24.4
DF52-12S-0.8H(21)	CL0668-0009-9-21	24.0	/	11.5	30.4	24.4
DF52-14S-0.8H(21)	CL0668-0024-2-21	24.0	/	11.5	30.4	24.4
DF52-15S-0.8H(21)	CL0668-0010-8-21	24.0	/	11.5	30.4	24.4
DF52-16S-0.8H(21)	CL0668-0025-5-21	24.0	/	11.5	30.4	24.4
DF52-17S-0.8H(21)	CL0668-0001-7-21	24.0	/	11.5	30.4	24.4
DF52-20S-0.8H(21)	CL0668-0011-0-21	32.0	28.4	14.2	38.4	32.4

HRS	DRAWING NO.	EDC3-356517-01
	PART NO.	DF52-*S-0.8H(21)
	CODE NO.	CL668-