

DO NOT SCALE FROM THIS PRINT

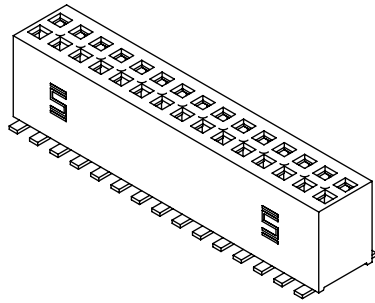

FLE-1XX-XX-XX-DV-XX-X-XX

No OF POSITIONS

-02 THRU -75 (PER ROW)

LEAD STYLE

-01: SURFACE MOUNT (USE C-96-01-XX)

PLATING SPECIFICATION

- G: 10µ" GOLD IN CONTACT AREA, 3µ" GOLD ON TAIL
- H: 30µ" HEAVY GOLD IN CONTACT AREA, 3µ" GOLD ON TAIL
- GF: 3µ" ON ENTIRE CONTACT

PACKAGING

- BLANK: TUBES (SEE NOTE 11 & 12)
- TR: TAPE & REEL (SEE NOTES 12 & 13)
- FR: FULL REEL QTY. TAPE & REEL (SEE NOTES 12 & 13)

PICK & PLACE OPTION

- P: PICK AND PLACE PAD (SEE FIG 4, SHT 2) (USE LMP-09, -05 POSITIONS MINIMUM)
- K: POLYIMIDE FILM PAD (SEE FIG 6, SHT 2) (USE K-DOT-.167-.281-.005) (-05 POSITIONS MINIMUM)

OPTION

- A: ALIGNMENT PIN (SEE FIG 2 & 3, SHT 2) (USE FLE-XX-D-XX) (MOLDED TO POSITION OR STAKED) (SAMTEC'S DISCRETION WHICH -A PIN IS USED) (MOLDED 3 POSITION MINIMUM) (STAKED 7 POSITION MINIMUM)

BODY SPECIFICATION

-DV: DOUBLE VERTICAL (USE FLE-75-D-XX)

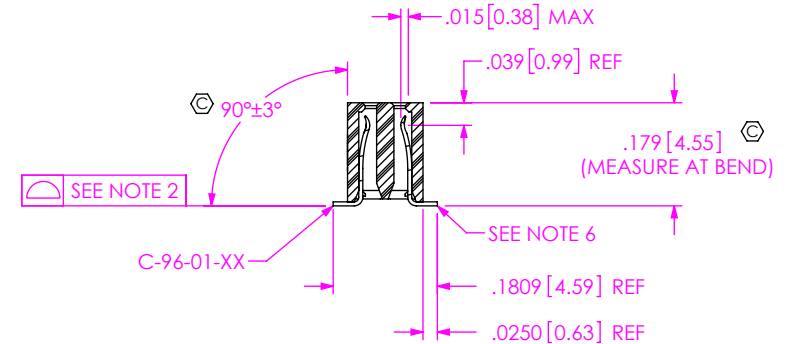
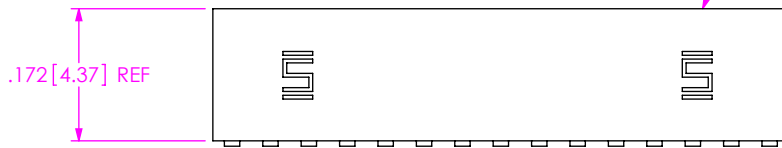
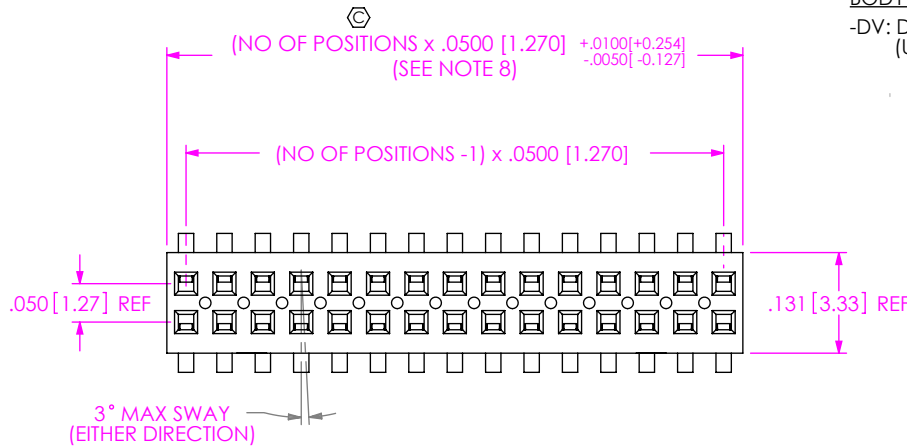

FIG 1
FLE-1XX-01-X-DV SHOWN

NOTES:

- ⊕ REPRESENTS A CRITICAL DIMENSION.
- ⊕ COPLANARITY: POSITIONS -2 THRU -26: .004 [.10]
POSITIONS -27 THRU -75: .006 [.15]
- MINIMUM PUSHOUT FORCE: .5 LB.
- PACKAGE POSITIONS -05 THRU -75 IN TUBES;
PACKAGE POSITIONS -02 THRU -04 IN ASBBLT4X5.5 BUBBLE BAGS.
- FOR EVERY FINISHED PART, ONE POSITION WILL BE LOST WHEN CUTTING BODY TO LENGTH.
- MAXIMUM BURR ALLOWANCE: .003 [.08].
- MAXIMUM CUT FLASH: .010 [.25] MAX WITH NO FLASH ALLOWED IN HOLES OR EXTENDING BELOW LEADS.
- THIS DIMENSION FOR 75 POSITIONS IS 3.759[95.47] REF.
- NOTE DELETED.
- NOTE DELETED.
- TUBES ARE STANDARD PACKAGING
- ORDERS WILL BE PACKAGED ACCORDING TO THE SAMTEC PACKAGING EFFICIENCY STANDARDS (SPES) FOUND ON WWW.SAMTEC.COM
- ATTACH LABEL TO EACH REEL.

UNLESS OTHERWISE SPECIFIED, DIMENSIONS ARE IN INCHES.
TOLERANCES ARE:
DECIMALS ANGLES
.XX: ±.01 [.3] 2°
.XXX: ±.005 [.13]
.XXXX: ±.0020 [.051]

PROPRIETARY NOTE
THIS DOCUMENT CONTAINS CONFIDENTIAL AND PROPRIETARY INFORMATION AND ALL DESIGN, MANUFACTURING, REPRODUCTION, USE, PATENT RIGHTS AND SALES RIGHTS ARE EXPRESSLY RESERVED BY SAMTEC, INC. THIS DOCUMENT SHALL NOT BE DISCLOSED, IN WHOLE OR PART, TO ANY UNAUTHORIZED PERSON OR ENTITY NOR REPRODUCED, TRANSFERRED OR INCORPORATED IN ANY OTHER PROJECT IN ANY MANNER WITHOUT THE EXPRESS WRITTEN CONSENT OF SAMTEC, INC.



520 PARK EAST BLVD., NEW ALBANY, IN 47150
PHONE: 812-944-6733 FAX: 812-948-5047
e-Mail: info@SAMTEC.com code 55322

MATERIAL: DO NOT SCALE DRAWING SHEET SCALE: 3:1
INSULATOR: VECTRA E130i, COLOR: BLACK
CONTACT: PHOS BRONZE

DESCRIPTION:
DUAL ROW .050 [1.27 X .050 [1.27] STRIP ASSEMBLY

DWG. NO.
FLE-1XX-XX-XX-DV-XX-X-XX

BY: D PURVIS 11/05/96 SHEET 1 OF 2

FIG 2
-A: OPTION
MOLDED ALIGNMENT PIN (3 POSITION MINIMUM)
(DIFFERENT AS SHOWN, OTHERWISE SAME AS FIG 1)

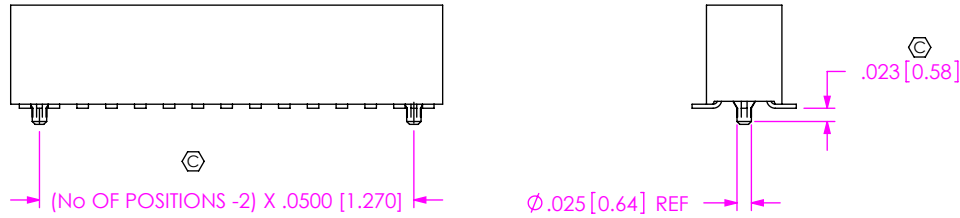
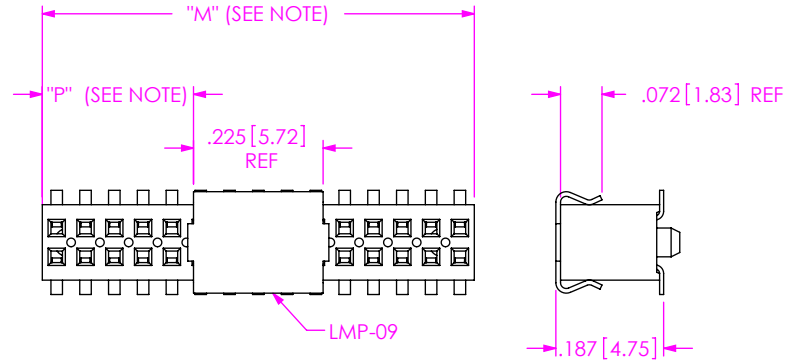

FIG 4
-P: OPTION
(USE LMP-09)
(DIFFERENT AS SHOWN, OTHERWISE SAME AS FIG 1)



NOTE: "M" = USED MEASURED DIMENSION (REF)
"P" = (("M" - .225 [5.71]/2) ± .020 [.51])

FIG 3
-A: OPTION
STAKED ALIGNMENT PIN (7 POSITION MINIMUM)
(DIFFERENT AS SHOWN, OTHERWISE SAME AS FIG 1)

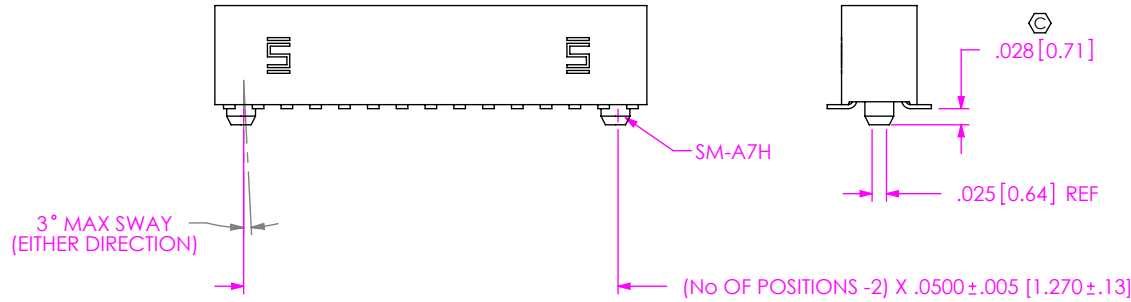
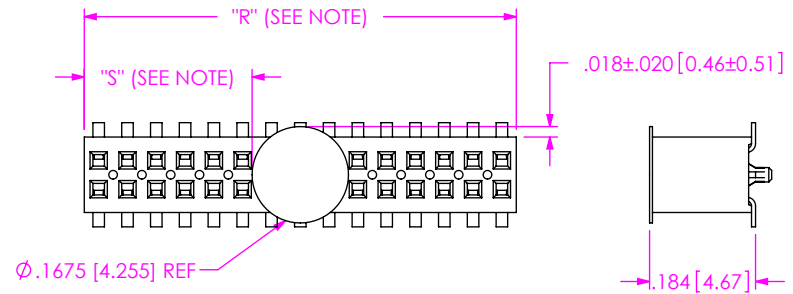

FIG 6
-K: OPTION (POLYIMIDE FILM PAD)
(DIFFERENT AS SHOWN, OTHERWISE SAME AS FIG 1)



NOTE: "R" = USED MEASURED DIMENSION (REF)
"S" = (("R" - .1675 [4.255]) / 2 ± .020 [.51])

c:\enterprisevault\DWG\MISC\MKTG\FLE-1XX-XX-XX-DV-XX-X-XX-MKT.SLDDRW

PACKAGING VIEW

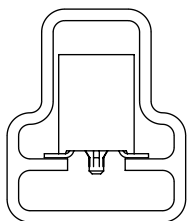

PT-1-24-01-43

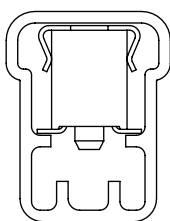

PT-1-24-13-09

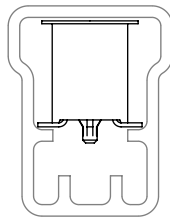

PT-1-24-13-09

PACKAGING TABLE (SEE NOTE 4)		
OPTION	TUBE	PLUG
WITHOUT -P	PT-1-24-01-43	TP-24
-P, -P-A	PT-1-24-13-09	TP-24
-K, -K-A	PT-1-24-13-09	TP-24

PROPRIETARY NOTE
THIS DOCUMENT CONTAINS CONFIDENTIAL AND PROPRIETARY INFORMATION AND ALL DESIGN, MANUFACTURING, REPRODUCTION, USE, PATENT RIGHTS AND SALES RIGHTS ARE EXPRESSLY RESERVED BY SAMTEC, INC. THIS DOCUMENT SHALL NOT BE DISCLOSED, IN WHOLE OR PART, TO ANY UNAUTHORIZED PERSON OR ENTITY NOR REPRODUCED, TRANSFERRED OR INCORPORATED IN ANY OTHER PROJECT IN ANY MANNER WITHOUT THE EXPRESS WRITTEN CONSENT OF SAMTEC, INC.

DO NOT SCALE DRAWING
SHEET SCALE: 3:1



520 PARK EAST BLVD, NEW ALBANY, IN 47150
PHONE: 812-944-6733 FAX: 812-948-5047
e-Mail info@SAMTEC.com code 55322

DESCRIPTION:
DUAL ROW .050 [1.27 X .050 [1.27] STRIP ASSEMBLY
DWG. NO.
FLE-1XX-XX-XX-DV-XX-X-XX
BY: D PURVIS 11/05/96 SHEET 2 OF 2