

TERMINAL
MATERIAL: BRASS
FINISH: ELECTRO-TIN

INSULATION
MATERIAL: PVC

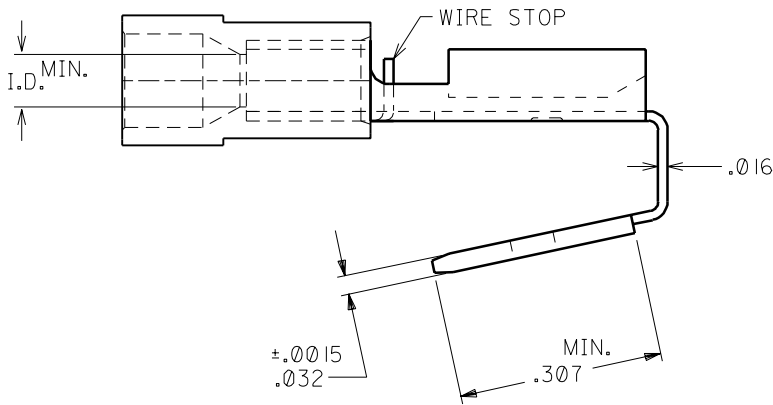

PART NO.	WIRE RANGE	INSULATION COLOR	MWID*	I.D. MIN.
AA-2301	22-18 AWG	RED	.135	.062
BB-2303	16-14 AWG	BLUE	.145	.081

*MWID = MAXIMUM WIRE INSULATION DIAMETER

A	NEW DRAWING RELEASE ETC50211 9/28 RCM
LTR.	REVISIONS

CUSTOMER DRAWING

DIMENSIONS SHOWN (METRIC) INCH UNLESS OTHERWISE SPECIFIED TOLERANCES: ANGULAR = 1/2°		REVISE ONLY ON CAD SYSTEM													
<table border="1"> <thead> <tr> <th></th> <th>INCH</th> <th>METRIC</th> </tr> </thead> <tbody> <tr> <td>3 PLACE</td> <td>± .005</td> <td>± ---</td> </tr> <tr> <td>2 PLACE</td> <td>± .01</td> <td>± 0.13</td> </tr> <tr> <td>1 PLACE</td> <td>± ---</td> <td>± 0.25</td> </tr> </tbody> </table>			INCH	METRIC	3 PLACE	± .005	± ---	2 PLACE	± .01	± 0.13	1 PLACE	± ---	± 0.25	TITLE INSULKRIMP PIGGY-BACK QUICK DISCONNECTS .250 X .032 TAB SIZE	
	INCH	METRIC													
3 PLACE	± .005	± ---													
2 PLACE	± .01	± 0.13													
1 PLACE	± ---	± 0.25													
DRAFT WHERE APPLICABLE MUST REMAIN WITHIN DIMENSIONS		<table border="1"> <tr> <td>molex ETC INC. PINELLAS PARK, FLA. 33781 U.S.A.</td> <td>SHEET NO.</td> <td>DATE</td> </tr> <tr> <td></td> <td></td> <td>95/09/28</td> </tr> </table>		molex ETC INC. PINELLAS PARK, FLA. 33781 U.S.A.	SHEET NO.	DATE			95/09/28						
molex ETC INC. PINELLAS PARK, FLA. 33781 U.S.A.	SHEET NO.	DATE													
		95/09/28													
<table border="1"> <tr> <td>DRWG. BY: RCM</td> <td>CHK'D. BY: RWD</td> </tr> <tr> <td>APP'D. BY: RWD</td> <td>SCALE: NO:NE</td> </tr> </table>		DRWG. BY: RCM	CHK'D. BY: RWD	APP'D. BY: RWD	SCALE: NO:NE	<table border="1"> <tr> <td>PART NO. SEE CHART</td> <td>DRWG. NO. CD-2907</td> </tr> <tr> <td>FILE NAME: CD2907.CST</td> <td>THIS DRAWING CONTAINS INFORMATION THAT IS PROPRIETARY TO MOLEX-ETC INC. AND SHOULD NOT BE USED WITHOUT WRITTEN PERMISSION.</td> </tr> </table>		PART NO. SEE CHART	DRWG. NO. CD-2907	FILE NAME: CD2907.CST	THIS DRAWING CONTAINS INFORMATION THAT IS PROPRIETARY TO MOLEX-ETC INC. AND SHOULD NOT BE USED WITHOUT WRITTEN PERMISSION.				
DRWG. BY: RCM	CHK'D. BY: RWD														
APP'D. BY: RWD	SCALE: NO:NE														
PART NO. SEE CHART	DRWG. NO. CD-2907														
FILE NAME: CD2907.CST	THIS DRAWING CONTAINS INFORMATION THAT IS PROPRIETARY TO MOLEX-ETC INC. AND SHOULD NOT BE USED WITHOUT WRITTEN PERMISSION.														
		DIV. B	SIZE B												