

**DESIGNED AND DIMENSIONED IN INCHES[MILLIMETERS]
ALL DIMENSIONS REFERENCE EXCEPT AS SHOWN**

**DO NOT
SCALE FROM
THIS PRINT**

292-J-P-EP-ST-CM-X-X

GENDER
-J: JACK

TYPE
-P: PCB

FINISH
-EP: 50µ" EXTRA HEAVY GOLD
CENTER CONTACT, PASSIVATED
OUTER CONTACT

PACKAGING
-K: INDIVIDUALLY BAGGED
-BLANK: TRAYS

OPTION
-1: OPTION 1 (WITHOUT SCREWS)
-2: OPTION 2 (WITH SCREWS)

TERMINATION
-CM: COMPRESSION MOUNT STRIPLINE

ORIENTATION
-ST: STRAIGHT

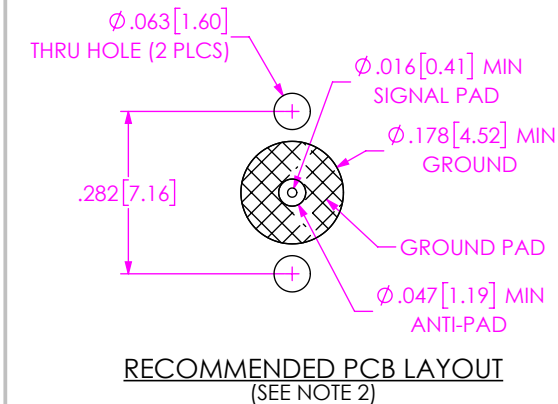
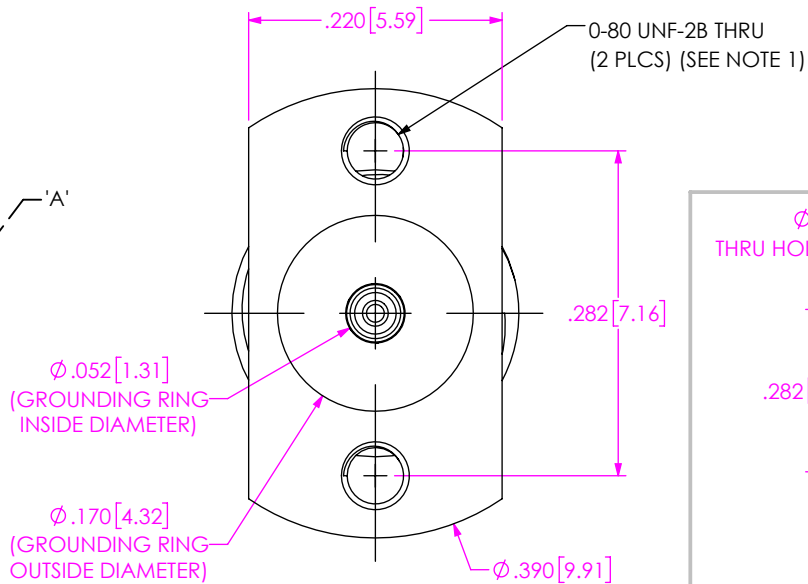
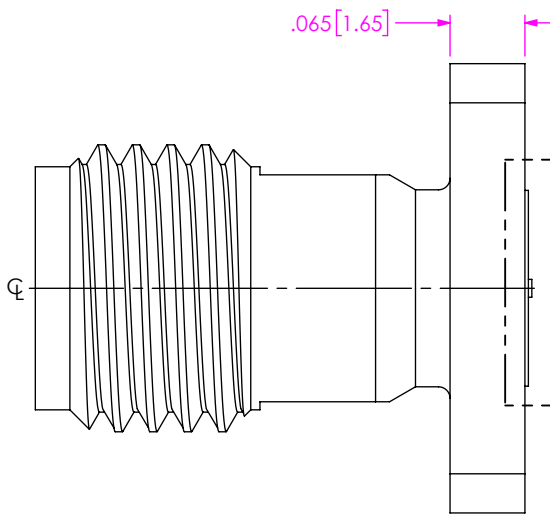
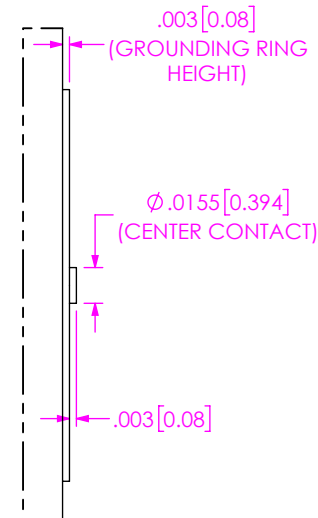
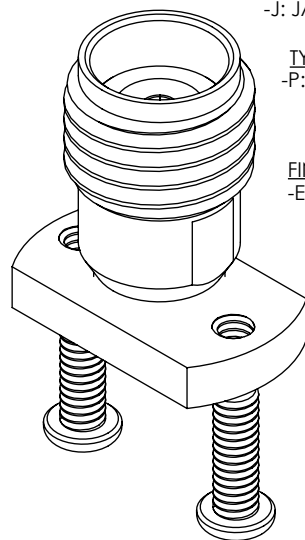
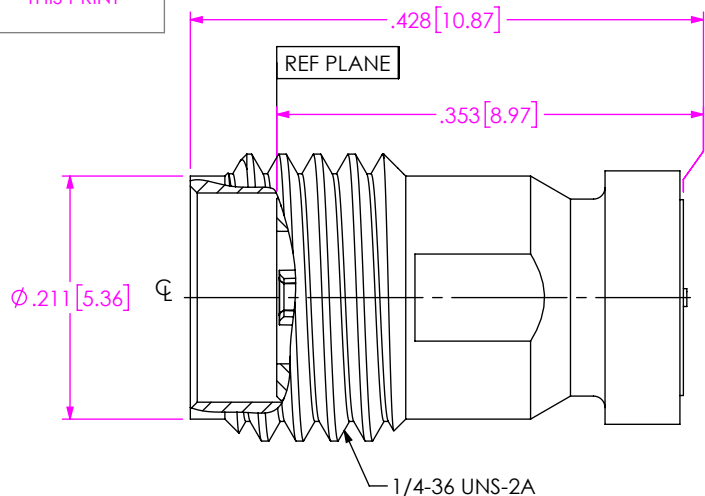

FIG 1
292-J-P-EP-ST-CM-X SHOWN

NOTES:

1. RECOMMENDED TORQUE 0.5-0.8 INCH-POUNDS.
2. THIS IS A GENERAL FOOTPRINT AND IS NOT OPTIMIZED FOR ELECTRICAL PERFORMANCE, CONTACT SIG@SAMTEC.COM FOR ASSISTANCE WITH ELECTRICAL LAYOUT.

PROPRIETARY NOTE
THIS DOCUMENT CONTAINS CONFIDENTIAL AND PROPRIETARY INFORMATION AND ALL DESIGN, MANUFACTURING, REPRODUCTION, USE, PATENT RIGHTS AND SALES RIGHTS ARE EXPRESSLY RESERVED BY SAMTEC, INC. THIS DOCUMENT SHALL NOT BE DISCLOSED, IN WHOLE OR PART, TO ANY UNAUTHORIZED PERSON OR ENTITY NOR REPRODUCED, TRANSFERRED OR INCORPORATED IN ANY OTHER PROJECT IN ANY MANNER WITHOUT THE EXPRESS WRITTEN CONSENT OF SAMTEC, INC.

DO NOT SCALE DRAWING
SHEET SCALE: 6:1

BODY, BUSHING & SCREW: STAINLESS STEEL
SOCKET: COPPER ALLOY

samtec
520 PARK EAST BLVD, NEW ALBANY, IN 47150
PHONE: 812-944-6733 FAX: 812-948-5047
e-Mail: info@SAMTEC.com code: 55322

DESCRIPTION:
2.92 MM ST JACK FOR COMPRESSION MOUNT STRIPLINE

DWG. NO.
292-J-P-EP-ST-CM-X-X