



DESIGNED AND DIMENSIONED IN MILLIMETERS [INCHES]
ALL DIMENSIONS REFERENCE EXCEPT AS SHOWN

ARC6-XX-XX.X-XX-XX-XX-X

No OF PAIRS
-08, -16, -24

CABLE LENGTH
-XX.X (INCHES)
(03.0[76.2] MIN)

END 1
-LU: LATCH UP

CABLE STYLE
-1: 34100

WIRING OPTION

- 2: PIN 1 TO PIN 2 (ONLY WITH END 2 -LD OPTION)
- 3: PIN 1 TO PIN N-1 (ONLY WITH END 2 -LU OPTION)
- 2R: PIN 1 TO PIN 2 (REVERSE POLARITY) (ONLY WITH END 2 -LD OPTION) (06.0 INCHES [152.4] MIN CABLE LENGTH)
- 3R: PIN 1 TO PIN N-1 (REVERSE POLARITY) (ONLY WITH END 2 -LU OPTION) (06.0 INCHES [152.4] MIN CABLE LENGTH)

END 2

- LU: LATCH UP
- LD: LATCH DOWN

TABLE 1

NO OF PAIRS	"A"
-08	10.90 [.429]
-16	18.52 [.729]
-24	26.14 [1.029]

TABLE 2

No. OF PAIRS	N	N-1
-08	26	25
-16	50	49
-24	74	73

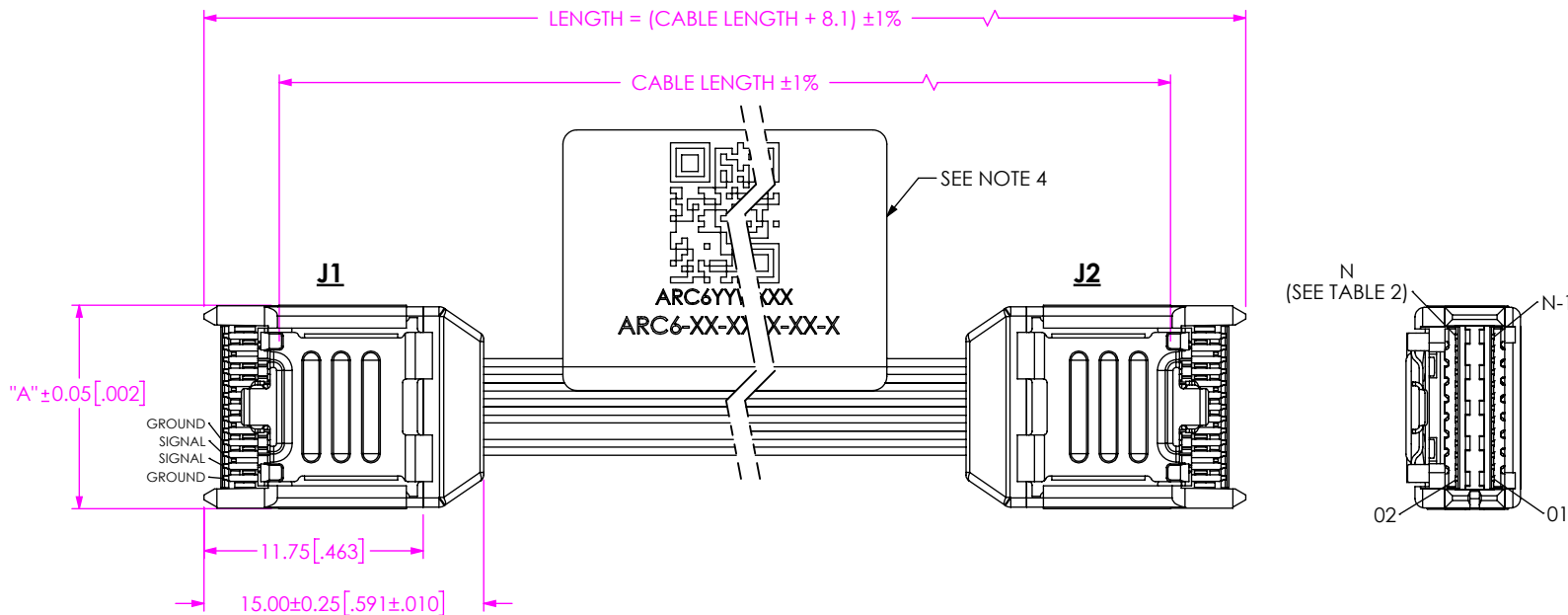
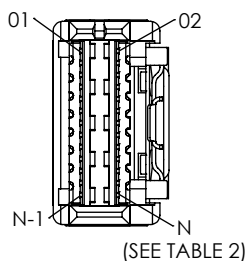

DO NOT SCALE FROM THIS PRINT

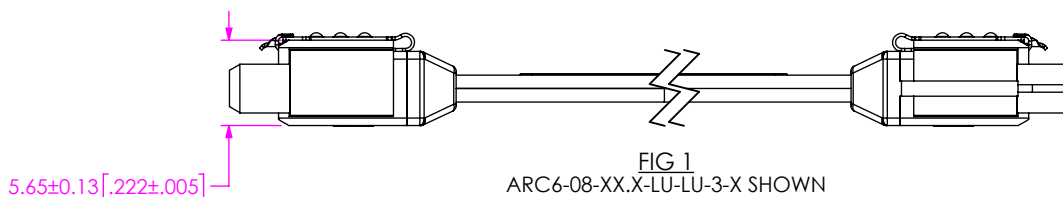

NOTES:

1. ALL ASSEMBLIES TO BE 100% HI-POT TESTED AT 300V.
2. ALL ASSEMBLIES TO BE 100% ELECTRICALLY TESTED FOR SHORTS AND OPENS.
3. CABLE LENGTHS OVER 40.0 [1016.0] NOT SUPPORTED BY SI TEST DATA.
4. LABEL TO BE CENTERED ON CABLE AS SHOWN. LABEL TO CONTAIN:
LINE 1 - QR CODE
LINE 2 - SERIAL NUMBER "ARC6YYWWXXXX"
LINE 3 - PART NUMBER "ARC6-XX-XX.X-XX-XX-XX-X"
5. "J1" TO BE LASER MARKED ON PLASTIC HOUSING FOR -2R AND -3R OPTIONS ONLY.

PROPRIETARY NOTE

THIS DOCUMENT CONTAINS CONFIDENTIAL AND PROPRIETARY INFORMATION AND ALL DESIGN, MANUFACTURING, REPRODUCTION, USE, PATENT RIGHTS AND SALES RIGHTS ARE EXPRESSLY RESERVED BY SAMTEC, INC. THIS DOCUMENT SHALL NOT BE DISCLOSED, IN WHOLE OR PART, TO ANY UNAUTHORIZED PERSON OR ENTITY NOR REPRODUCED, TRANSFERRED OR INCORPORATED IN ANY OTHER PROJECT IN ANY MANNER WITHOUT THE EXPRESS WRITTEN CONSENT OF SAMTEC, INC.

DO NOT SCALE DRAWING
SHEET SCALE: 2:1

MATERIAL:
INSULATOR: LCP
TERMINALS: COPPER ALLOY
LATCH: SS



520 PARK EAST BLVD., NEW ALBANY, IN 47150
PHONE: 812-944-6733 FAX: 812-948-5047
e-Mail info@SAMTEC.com code 55322

DESCRIPTION: ARC6 CABLE ASSEMBLY

DWG. NO. ARC6-XX-XX.X-XX-XX-XX-X

BY: JOE Z 08/12/2017 SHEET 1 OF 4

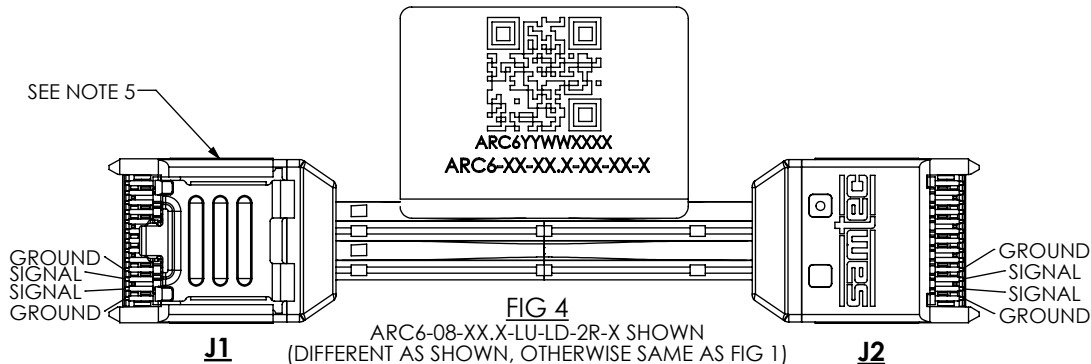
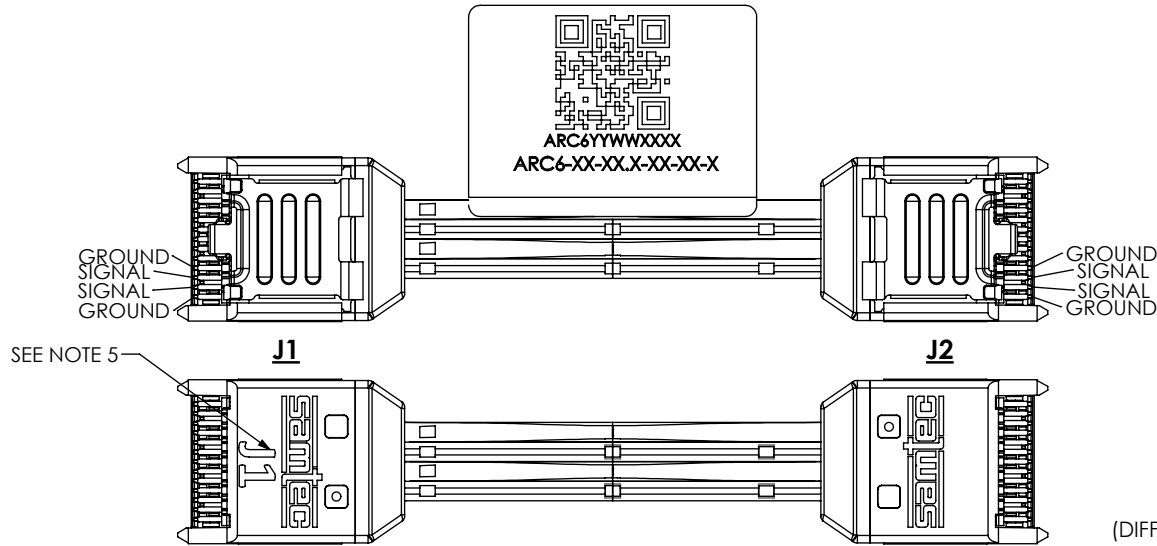
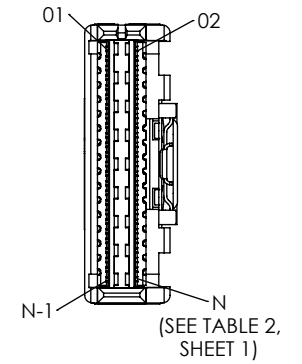
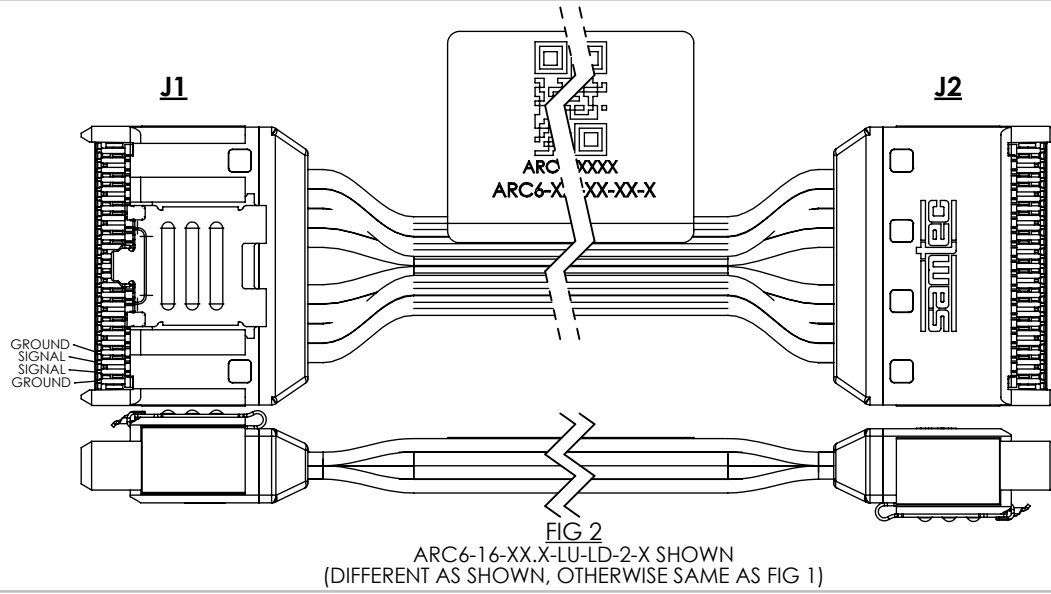
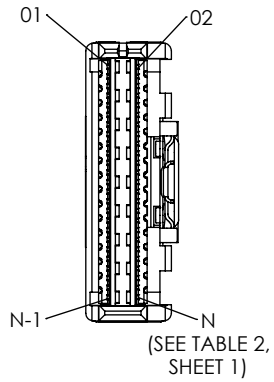

PROPRIETARY NOTE
THIS DOCUMENT CONTAINS CONFIDENTIAL AND PROPRIETARY INFORMATION AND ALL DESIGN, MANUFACTURING, REPRODUCTION, USE, PATENT RIGHTS AND SALES RIGHTS ARE EXPRESSLY RESERVED BY SAMTEC, INC. THIS DOCUMENT SHALL NOT BE DISCLOSED, IN WHOLE OR PART, TO ANY UNAUTHORIZED PERSON OR ENTITY NOR REPRODUCED, TRANSFERRED OR INCORPORATED IN ANY OTHER PROJECT IN ANY MANNER WITHOUT THE EXPRESS WRITTEN CONSENT OF SAMTEC, INC.

DO NOT SCALE DRAWING
SHEET SCALE: 2:1



520 PARK EAST BLVD, NEW ALBANY, IN 47150
PHONE: 812-944-6733 FAX: 812-948-5047
e-Mail: info@SAMTEC.com code 55322

DESCRIPTION: **ARC6 CABLE ASSEMBLY**
DWG. NO. **ARC6-XX-XX.X-XX-XX-XX-X**
BY: JOE Z 08/12/2017 SHEET 2 OF 4

ARC6-08-XX.X-XX-XX-XX-X SIGNAL MAPPING																											
WIRING OPTION	POSITIONS																										
-2 (PIN1 TO PIN 2)	J1	1	3	5	7	9	11	13	15	17	19	21	23	25	2	4	6	8	10	12	14	16	18	20	22	24	26
	NAME	GND1	PAIR	GND1	PAIR	GND1	PAIR	GND1	PAIR	GND1	PAIR	GND1	PAIR	GND1	GND2	PAIR	GND2	PAIR	GND2	PAIR	GND2	PAIR	GND2	PAIR	GND2	PAIR	GND2
	J2	2	4	6	8	10	12	14	16	18	20	22	24	26	1	3	5	7	9	11	13	15	17	19	21	23	25
-3 (PIN1 TO PIN N-1)	J1	1	3	5	7	9	11	13	15	17	19	21	23	25	2	4	6	8	10	12	14	16	18	20	22	24	26
	NAME	GND1	PAIR	GND1	PAIR	GND1	PAIR	GND1	PAIR	GND1	PAIR	GND1	PAIR	GND1	GND2	PAIR	GND2	PAIR	GND2	PAIR	GND2	PAIR	GND2	PAIR	GND2	PAIR	GND2
	J2	25	23	21	19	17	15	13	11	9	7	5	3	1	26	24	22	20	18	16	14	12	10	8	6	4	2
-2R (PIN1 TO PIN 2)	J1	1	3	5	7	9	11	13	15	17	19	21	23	25	2	4	6	8	10	12	14	16	18	20	22	24	26
	NAME	GND1	PAIR	GND1	PAIR	GND1	PAIR	GND1	PAIR	GND1	PAIR	GND1	PAIR	GND1	GND2	PAIR	GND2	PAIR	GND2	PAIR	GND2	PAIR	GND2	PAIR	GND2	PAIR	GND2
	J2	2	6	4	8	10	12	14	18	16	20	22	24	26	1	3	5	7	11	9	13	15	17	19	23	21	25
-3R (PIN1 TO PIN N-1)	J1	1	3	5	7	9	11	13	15	17	19	21	23	25	2	4	6	8	10	12	14	16	18	20	22	24	26
	NAME	GND1	PAIR	GND1	PAIR	GND1	PAIR	GND1	PAIR	GND1	PAIR	GND1	PAIR	GND1	GND2	PAIR	GND2	PAIR	GND2	PAIR	GND2	PAIR	GND2	PAIR	GND2	PAIR	GND2
	J2	25	21	23	19	17	15	13	9	11	7	5	3	1	26	24	22	20	16	18	14	12	10	8	4	6	2
ALL LIKE NAMED GROUNDS ARE COMMON AND TIED TO CABLE SHIELD																											
ON THE MATING BOARD ASSEMBLY, SAMTEC RECOMMENDS IMPLEMENTING A GND REFERENCE TYING ALL GND'S TOGETHER																											

ARC6-16-XX.X-XX-XX-XX-X SIGNAL MAPPING																										
WIRING OPTION	POSITIONS																									
-2 (PIN1 TO PIN 2)	J1	1	3	5	7	9	11	13	15	17	19	21	23	25	27	29	31	33	35	37	39	41	43	45	47	49
	NAME	GND1	PAIR	GND1	PAIR	GND1	PAIR	GND1	PAIR	GND1	PAIR	GND1	PAIR	GND1	PAIR	GND1	PAIR	GND1	PAIR	GND1	PAIR	GND1	PAIR	GND1	PAIR	GND1
	J2	2	4	6	8	10	12	14	16	18	20	22	24	26	28	30	32	34	36	38	40	42	44	46	48	50
	J1	2	4	6	8	10	12	14	16	18	20	22	24	26	28	30	32	34	36	38	40	42	44	46	48	50
	NAME	GND2	PAIR	GND2	PAIR	GND2	PAIR	GND2	PAIR	GND2	PAIR	GND2	PAIR	GND2	PAIR	GND2	PAIR	GND2	PAIR	GND2	PAIR	GND2	PAIR	GND2	PAIR	GND2
	J2	1	3	5	7	9	11	13	15	17	19	21	23	25	27	29	31	33	35	37	39	41	43	45	47	49
-3 (PIN1 TO PIN N-1)	J1	1	3	5	7	9	11	13	15	17	19	21	23	25	27	29	31	33	35	37	39	41	43	45	47	49
	NAME	GND1	PAIR	GND1	PAIR	GND1	PAIR	GND1	PAIR	GND1	PAIR	GND1	PAIR	GND1	PAIR	GND1	PAIR	GND1	PAIR	GND1	PAIR	GND1	PAIR	GND1	PAIR	GND1
	J2	49	47	45	43	41	39	37	35	33	31	29	27	25	23	21	19	17	15	13	11	9	7	5	3	1
	J1	2	4	6	8	10	12	14	16	18	20	22	24	26	28	30	32	34	36	38	40	42	44	46	48	50
	NAME	GND2	PAIR	GND2	PAIR	GND2	PAIR	GND2	PAIR	GND2	PAIR	GND2	PAIR	GND2	PAIR	GND2	PAIR	GND2	PAIR	GND2	PAIR	GND2	PAIR	GND2	PAIR	GND2
	J2	50	48	46	44	42	40	38	36	34	32	30	28	26	24	22	20	18	16	14	12	10	8	6	4	2
-2R (PIN1 TO PIN 2)	J1	1	3	5	7	9	11	13	15	17	19	21	23	25	27	29	31	33	35	37	39	41	43	45	47	49
	NAME	GND1	PAIR	GND1	PAIR	GND1	PAIR	GND1	PAIR	GND1	PAIR	GND1	PAIR	GND1	PAIR	GND1	PAIR	GND1	PAIR	GND1	PAIR	GND1	PAIR	GND1	PAIR	GND1
	J2	2	6	4	8	10	12	14	18	16	20	22	24	26	30	28	32	34	36	38	42	40	44	46	48	50
	J1	2	4	6	8	10	12	14	16	18	20	22	24	26	28	30	32	34	36	38	40	42	44	46	48	50
	NAME	GND2	PAIR	GND2	PAIR	GND2	PAIR	GND2	PAIR	GND2	PAIR	GND2	PAIR	GND2	PAIR	GND2	PAIR	GND2	PAIR	GND2	PAIR	GND2	PAIR	GND2	PAIR	GND2
	J2	1	3	5	7	11	9	13	15	17	19	23	21	25	27	29	31	35	33	37	39	41	43	47	45	49
-3R (PIN1 TO PIN N-1)	J1	1	3	5	7	9	11	13	15	17	19	21	23	25	27	29	31	33	35	37	39	41	43	45	47	49
	NAME	GND1	PAIR	GND1	PAIR	GND1	PAIR	GND1	PAIR	GND1	PAIR	GND1	PAIR	GND1	PAIR	GND1	PAIR	GND1	PAIR	GND1	PAIR	GND1	PAIR	GND1	PAIR	GND1
	J2	49	45	47	43	41	39	37	33	35	31	29	27	25	21	23	19	17	15	13	9	11	7	5	3	1
	J1	2	4	6	8	10	12	14	16	18	20	22	24	26	28	30	32	34	36	38	40	42	44	46	48	50
	NAME	GND2	PAIR	GND2	PAIR	GND2	PAIR	GND2	PAIR	GND2	PAIR	GND2	PAIR	GND2	PAIR	GND2	PAIR	GND2	PAIR	GND2	PAIR	GND2	PAIR	GND2	PAIR	GND2
	J2	50	48	46	44	40	42	38	36	34	32	28	30	26	24	22	20	16	18	14	12	10	8	4	6	2
ALL LIKE NAMED GROUNDS ARE COMMON AND TIED TO CABLE SHIELD																										
ON THE MATING BOARD ASSEMBLY, SAMTEC RECOMMENDS IMPLEMENTING A GND REFERENCE TYING ALL GND'S TOGETHER																										

PROPRIETARY NOTE
 THIS DOCUMENT CONTAINS CONFIDENTIAL AND PROPRIETARY INFORMATION AND ALL DESIGN, MANUFACTURING, REPRODUCTION, USE, PATENT RIGHTS AND SALES RIGHTS ARE EXPRESSLY RESERVED BY SAMTEC, INC. THIS DOCUMENT SHALL NOT BE DISCLOSED, IN WHOLE OR PART, TO ANY UNAUTHORIZED PERSON OR ENTITY NOR REPRODUCED, TRANSFERRED OR INCORPORATED IN ANY OTHER PROJECT IN ANY MANNER WITHOUT THE EXPRESS WRITTEN CONSENT OF SAMTEC, INC.



DO NOT SCALE DRAWING
 SHEET SCALE: 2:1

DESCRIPTION:
 ARC6 CABLE ASSEMBLY
 DWG. NO.
ARC6-XX-XX.X-XX-XX-XX-X
 BY: JOE Z 08/12/2017 SHEET 3 OF 4

