

P/N OF ADAPTER	MATERIAL OF SLEEVE
86152-1000	CERAMIC
86156-1000	PHOSPHOR BRONZE

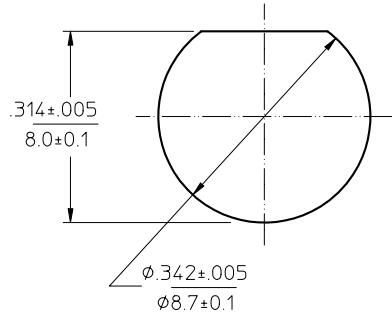
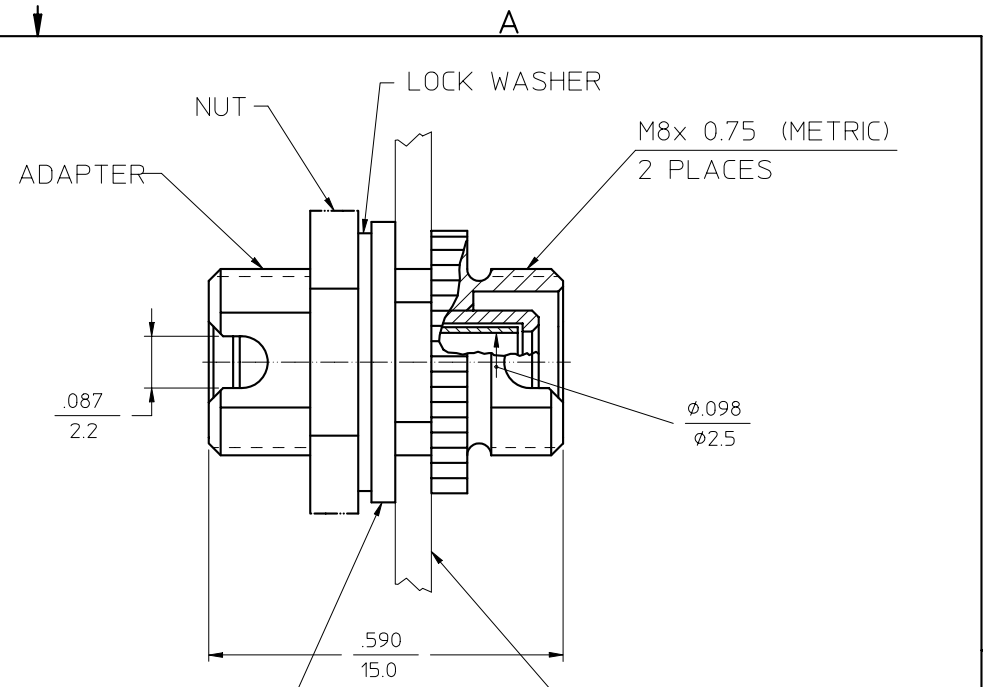
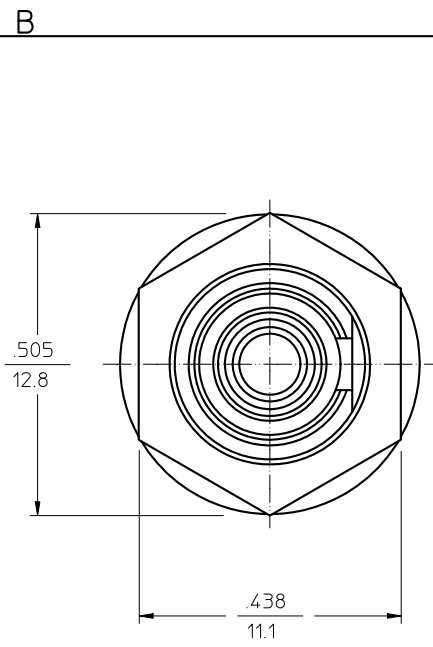

NOTES:

- ALL DIMENSIONS ARE GIVEN IN $\frac{\text{INCHES}}{\text{mm}}$.
- FOR THE USE OF WASHERS ACCORDING TO THE PANEL THICKNESS SEE FOLLOWING TABLE:

PANEL THICKNESS	USE WASHER
$\frac{.047}{12}$ TO $\frac{.060}{1.5}$	BOTH WASHERS
$\frac{.061}{1.55}$ TO $\frac{.085}{2.15}$	FLAT WASHER
$\frac{.086}{2.2}$ TO $\frac{.102}{2.6}$	LOCK WASHER

RECOMMENDED MOUNTING HOLE

molex ® Fiber Optics		Downers Grove, Illinois	
TITLE: 'D' HOLE FC TYPE ADAPTER		Size	Scale 5:1 REV E
Drawing No. 8615X-1000 CD		B	Sheet 1 of 1

RESTRICTED RELEASE
DRAWING MAY CHANGE WITHOUT
CUSTOMER NOTIFICATION

B

A

B

A