

Oct.1.2022 Copyright 2022 HIROSE ELECTRIC CO., LTD. All Rights Reserved.
In case of consideration for using Automotive equipment / device which demand high reliability, kindly contact our sales window correspondents.

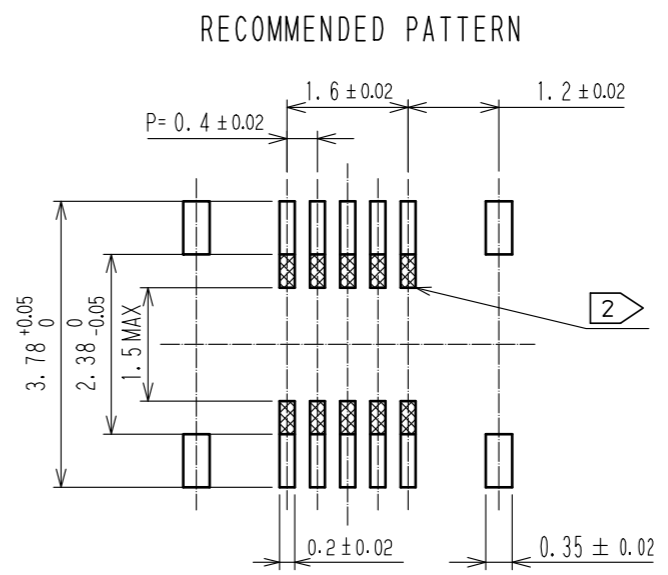

RECOMMENDED METAL MASK THICKNESS : 120#m
RECOMMENDED MASK OPENING RATIO : 80% FOR LEAD PAD

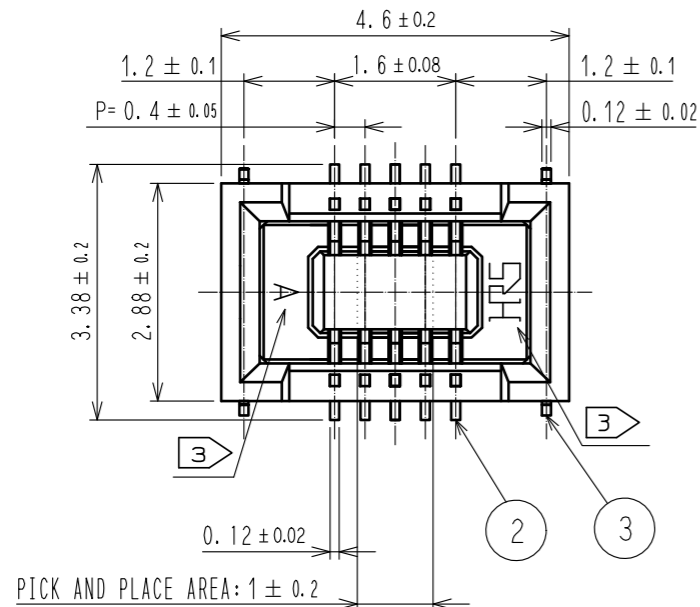
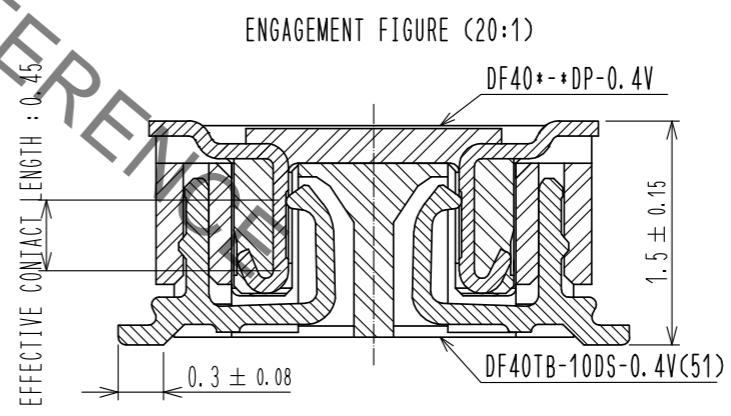
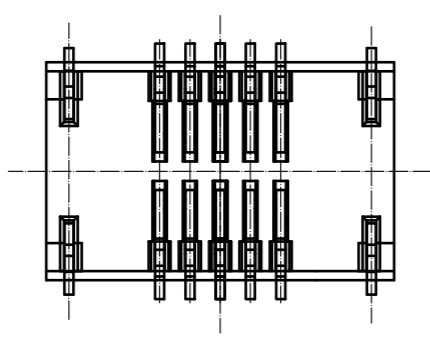
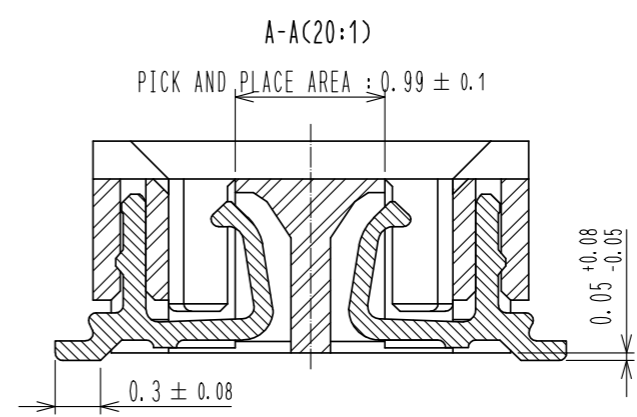
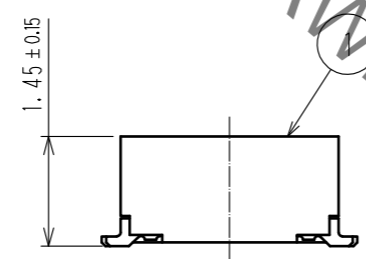
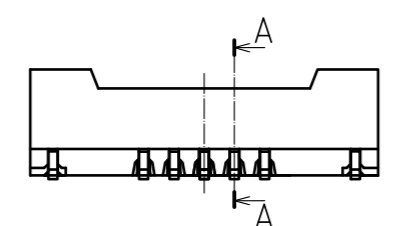

NOTE 1. ALL LEADS CO-PLANARITY SHALL BE 0.1 MAX.
 2 IS NO PATTERN AREA OTHER THAN THE SAME CIRCUIT.
 3 HRS MARK AND CAV NO. ARE INDICATED IN APPROX. POSITION SHOWN.

3	COPPER ALLOY	GOLD 0.05#m MIN UNDERPLATING-NICKEL 1#m MIN	7	PS	CLEAR-REINFORCEMENT COLLAR
			6	PS	BLACK-PLASTIC REEL
2	COPPER ALLOY	GOLD 0.05#m MIN UNDERPLATING-NICKEL 1#m MIN	5	POLYESTER	CLEAR-COVER TAPE
			4	PS	CLEAR(EMBOSSED CARRIER TAPE)
1	LCP	UL94V-0-BLACK			
NO.	MATERIAL	FINISH , REMARKS	NO.	MATERIAL	FINISH , REMARKS
UNITS mm		SCALE 10:1	COUNT 1	DESCRIPTION OF REVISIONS DIS-H-00005725	
APPROVED : WR. FUKUCHI 20191122			DESIGNED YK. SATAKE		
CHECED : TS. MIYAZAKI 20191122			CHECKED TS. MIYAZAKI		
DESIGNED : YK. SATAKE 20191122			DATE 20200204		
DRAWN : YK. SATAKE 20191122			DRAWING NO. EDC-388250-51-00		
HRS HIROSE ELECTRIC CO., LTD.			PART NO. DF40TB-10DS-0.4V(51)		
			CODE NO. CL684-4273-0-51		

Oct.1.2022 Copyright 2022 HIROSE ELECTRIC CO., LTD. All Rights Reserved.
 In case of consideration for using Automotive equipment / device which demand high reliability, kindly contact our sales window correspondents.

EMBOSSED CARRIER TAPE PACKAGING (5:1)

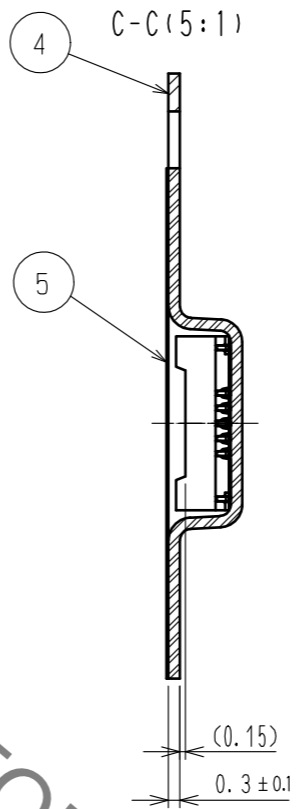
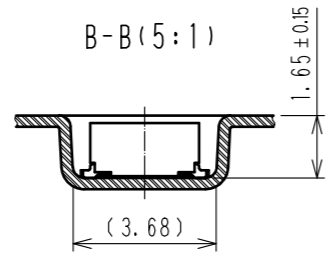
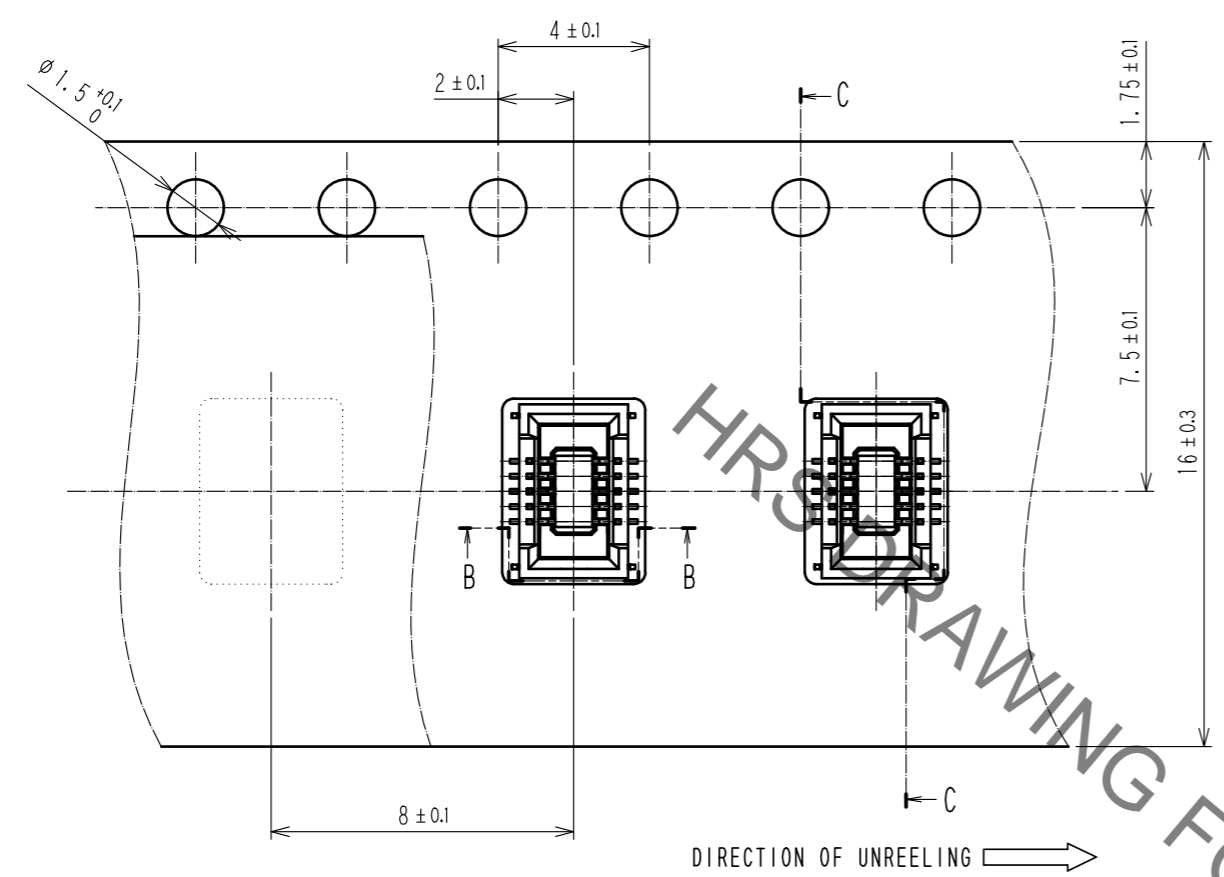

STYLE AND DIMENSIONS OF REEL (FREE)

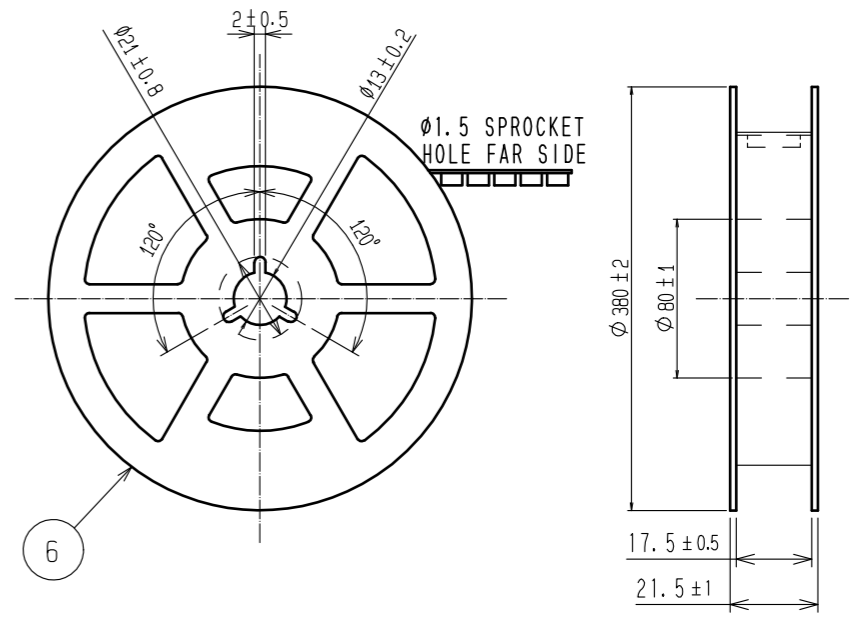

- NOTES
- 4. PER REEL 5000 CONNECTORS.
 - 5. THE DIMENSIONS IN PARENTHESES ARE FOR REFERENCE.
 - 6 REFER TO JIS C 0806 (PACKING OF COMPONENTS FOR AUTOMATIC HANDLING)
 - 7 AFTER PACKAGING, ROLL 2 METERS OF THE REINFORCEMENT COLLAR TO OUTER CIRCUMFERENCE OF TAPE AND REEL POCKET, AND TAPE DOWN AT THE END THE COLLAR.

PORTION EQUIPPED WITH CONNECTORS (FREE)

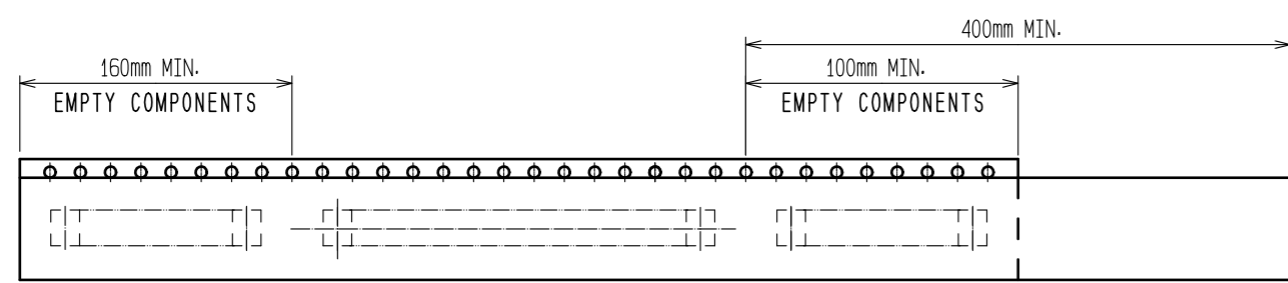

H-H (FREE)

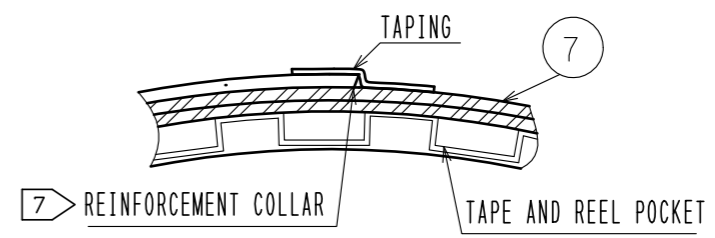

HRS	DRAWING NO.	EDC-388250-51-00
	PART NO.	DF40TB-10DS-0.4V(51)
	CODE NO.	CL684-4273-0-51
		2/2