

THIS DRAWING IS UNPUBLISHED. RELEASED FOR PUBLICATION
 © COPYRIGHT 2016 TE CONNECTIVITY ALL RIGHTS RESERVED.

REVISIONS				
P	LTR	DESCRIPTION	DATE	APVD
A		RELEASE TO PRODUCTION	20SEP2022	DK PS

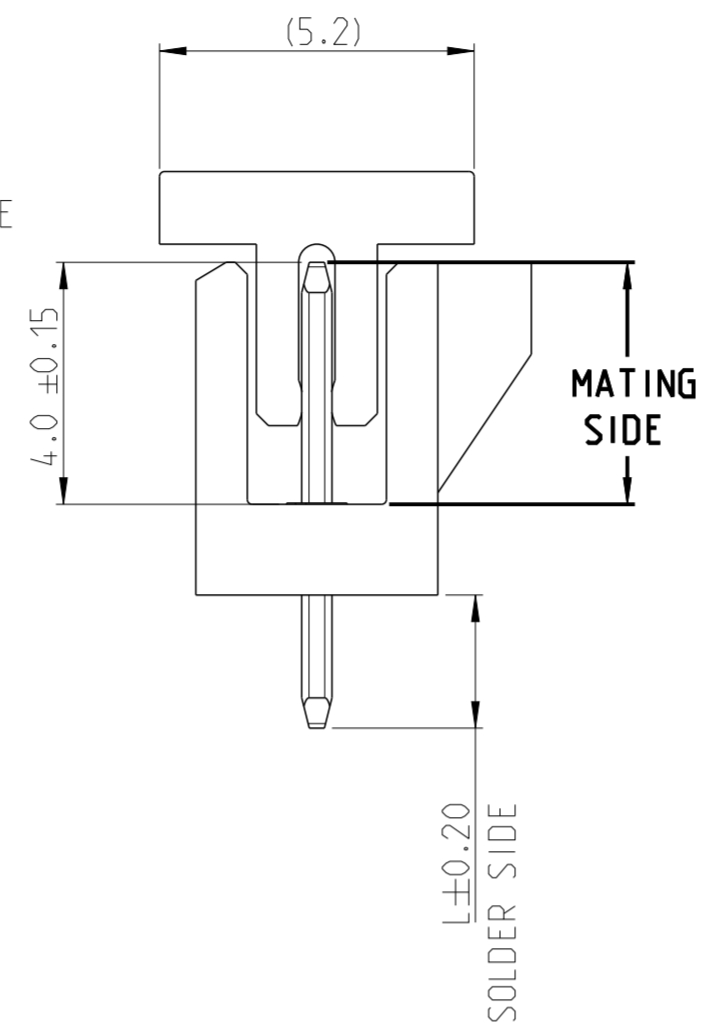

- NOTES:
- MATERIAL
 HOUSING & CAP : HIGH TEMPERATURE THERMOPLASTIC, UL94-V0;COLOR- BLACK
 POST : PHOSPHOR BRONZE
 - FINISH :
 - 3 - 5 μm TIN OVER MIN 1.27 μm NICKEL UNDER PLATING
 - MATING SIDE: MIN 0.38 μm GOLD OVER MIN 1.27 μm NICKEL UNDER PLATING
 SOLDER SIDE: 4 - 6 μm TIN OVER MIN 1.27 μm NICKEL UNDER PLATING
 - MATING SIDE: MIN 0.76 μm GOLD OVER MIN 1.27 μm NICKEL UNDER PLATING
 SOLDER SIDE: 4 - 6 μm TIN OVER MIN 1.27 μm NICKEL UNDER PLATING
 - FOR SMART PART NUMBER, NO. OF POSITIONS PER CONNECTOR HAS TO BE ADDED NEXT TO NO. OF ROWS (2MM-HSP-S__-VT-__-__-__). REFER SHEET 2 NOMENCLATURE.
 FOR EXAMPLE: 2MM-HSP-S03-VT-01-T-TB = 3 POSITION.
 2MM-HSP-S16-VT-01-T-TB = 16 POSITION.
 - PACKAGING: A. TAPE & REEL WITH (W/) CAP.
 B. TUBE WITH (W/) AND WITHOUT (W/O) CAP.
 C. BOX WITHOUT (W/O) CAP.
 - PART NUMBER AVAILABLE UPON CUSTOMER REQUEST.

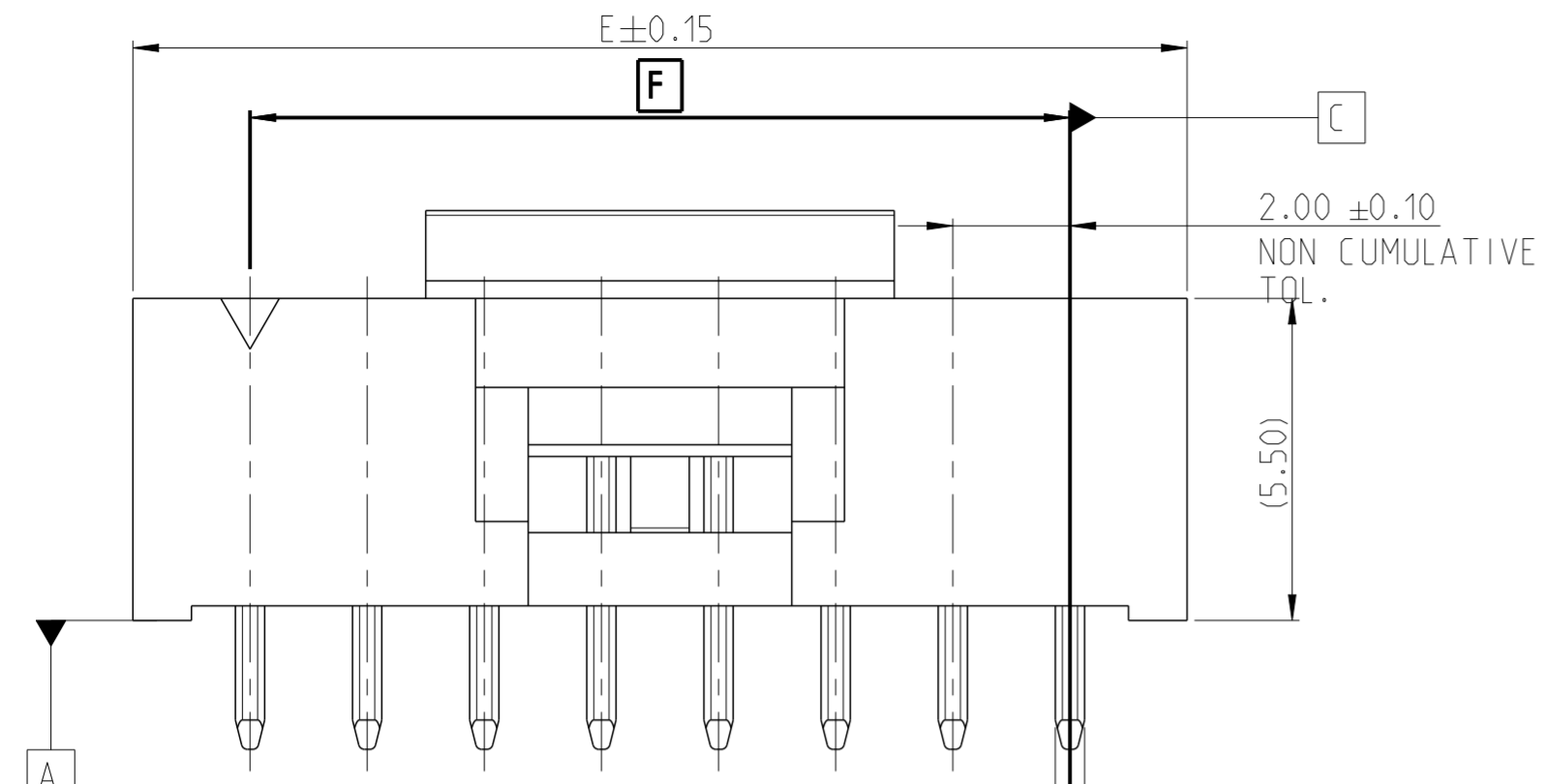
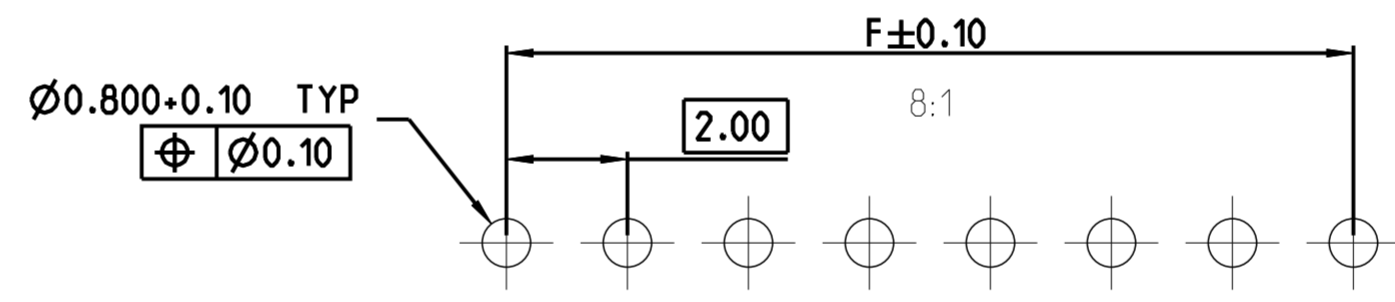
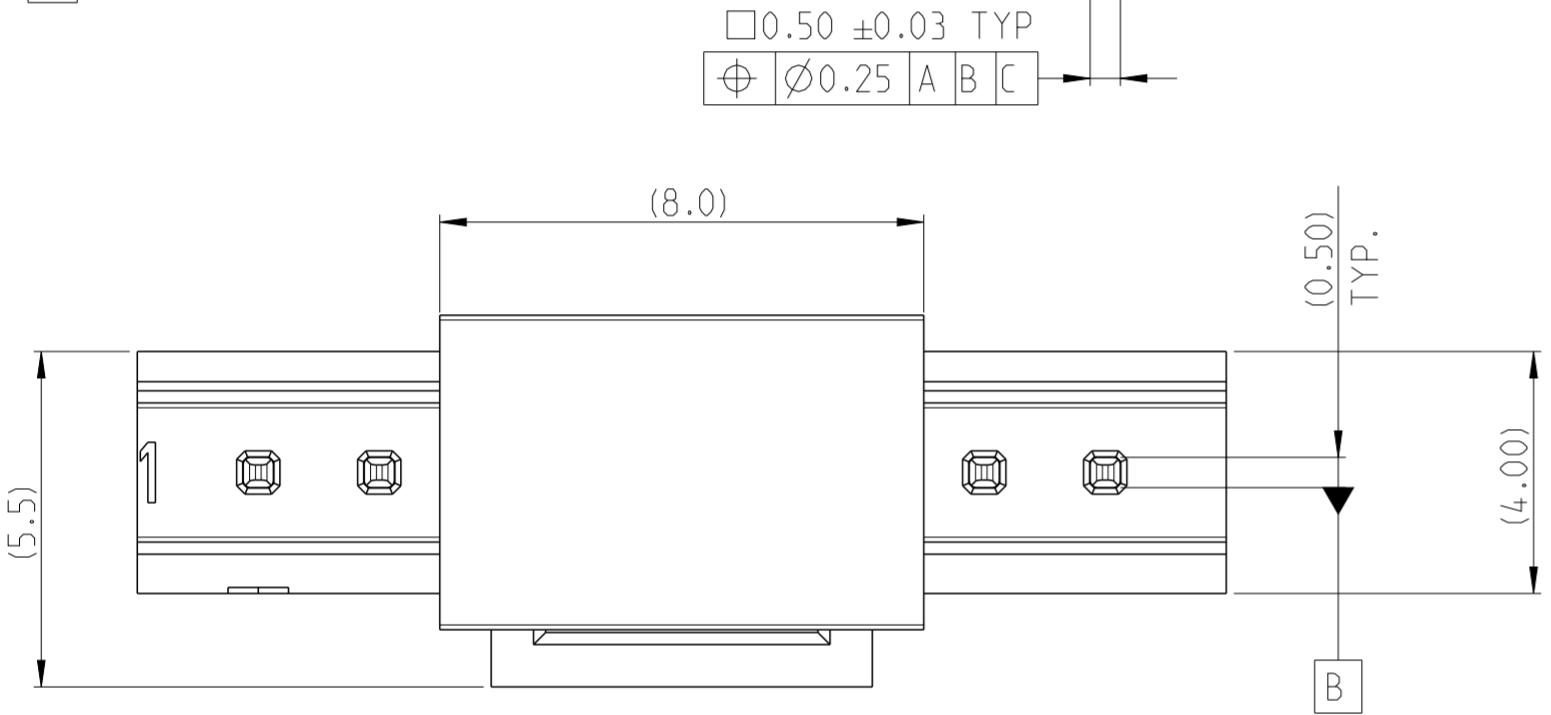

RECOMMENDED PCB HOLE PATTERN FOR THROUGH HOLE WAVE

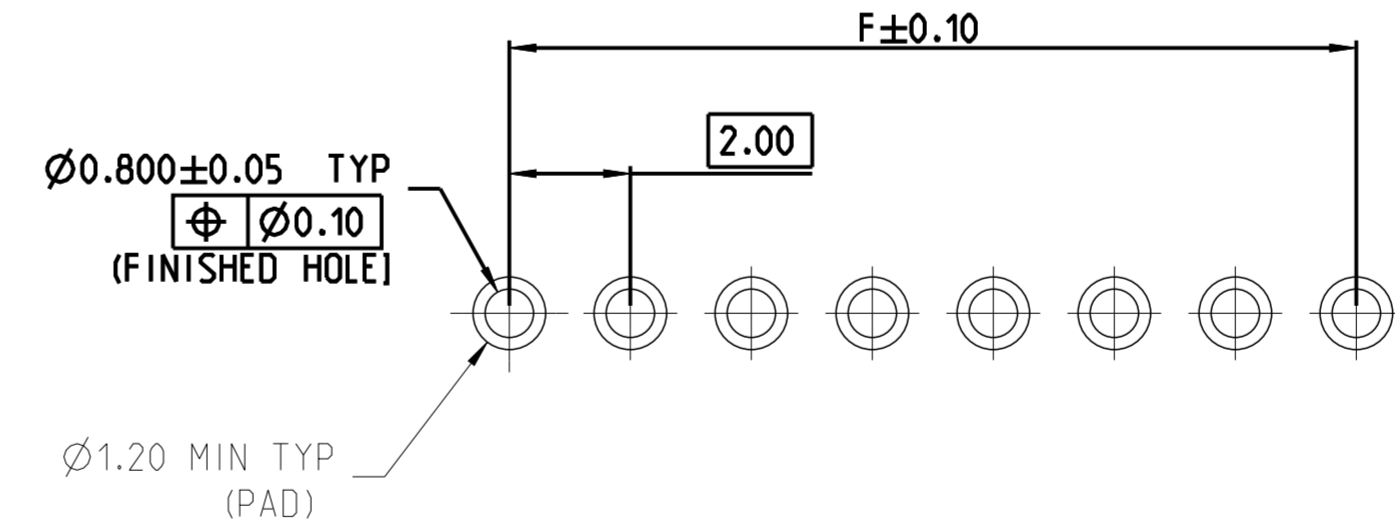

RECOMMENDED PCB HOLE PATTERN FOR THROUGH HOLE REFLOW / PIN-IN-PASTE

30	34	16
28	32	15
26	30	14
24	28	13
22	26	12
20	24	11
18	22	10
16	20	9
14	18	8
12	16	7
10	14	6
8	12	5
6	10	4
4	8	3
DIM "F"	DIM "E"	POSITION PER CONNECTOR

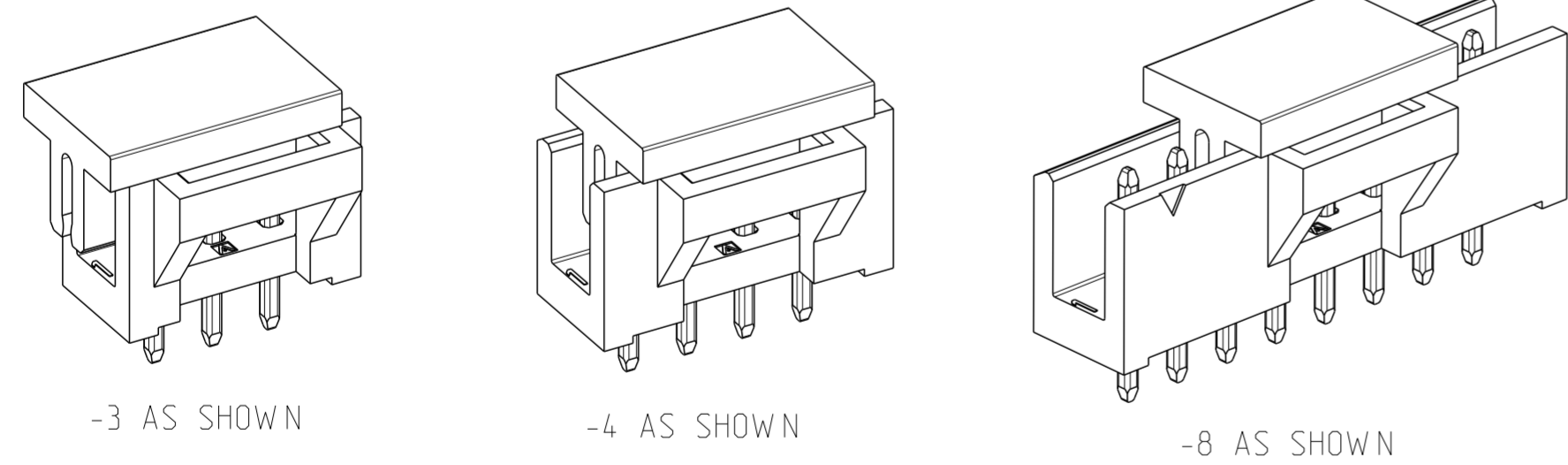

THIS DRAWING IS A CONTROLLED DOCUMENT.

DIMENSIONS: mm	TOLERANCES UNLESS OTHERWISE SPECIFIED:	DWN: R R NAYAK 6APR2016	TE Connectivity NAME: AMPMODU 2mm SHROUDED MTE HEADER SINGLE ROW, VERTICAL SIZE: A2 CAGE CODE: 100779 DRAWING NO: 2823174 RESTRICTED TO: -
0 PLC ±	1 PLC ±0.1	CHK: KARTHIK J K 27JUN2016	
2 PLC ±0.05	3 PLC ±	APVD: PRASHANTH S 27JUN2016	
4 PLC ±	ANGLES ±2°	PRODUCT SPEC: 108-64040	
MATERIAL: SEE NOTES	FINISH: SEE NOTES	APPLICATION SPEC: 114-64040	WEIGHT: -
CUSTOMER DRAWING		SCALE: 8:1	SHEET: 1 OF 2 REV: A

THIS DRAWING IS UNPUBLISHED. RELEASED FOR PUBLICATION
 © COPYRIGHT 2016 TE CONNECTIVITY ALL RIGHTS RESERVED.

REVISIONS					
P	LTR	DESCRIPTION	DATE	DWN	APVD
-		SEE SHEET 1	-	-	-

SMART PART NUMBER
 2MM - HSP - S ___ - VT - ___ - ___ - ___

PRODUCT SERIES

2MM AMPMODU 2mm series

GENDER / TYPE

HSP Shrouded headers for positive latch

NUMBER OF ROWS

S Single row

NUMBER OF PINS PER ROW

XX 03 through 16 (enter two digits)

ORIENTATION & TERMINATION

VT Vertical through hole

PACKAGING

TB	Tube without cap
TBP	Tube with cap
TRP	Tape and reel with cap
BX	Box

PLATING

T	Tin
M	0.38 μm Gold
H	0.76 μm Gold

TAIL LENGTH (L)

01	2.2 mm
02	2.8 mm

SMART PN EXAMPLES :

1. AMPMODU 2MM, SHROUDED HEADER CENTER LATCH VERSION , SINGLE ROW , 03 POSITION PER ROW , VERTICAL MOUNT , 2.2MM SOLDER TAIL LENGTH, TIN PLATING, TUBE W/O CAP
2MM-HSP-S03-VT-01-T-TB
2. AMPMODU 2MM, SHROUDED HEADER CENTER LATCH VERSION, SINGLE ROW , 16 POSITION PER ROW , VERTICAL MOUNT , 2.8MM SOLDER TAIL LENGTH, 0.76 μm GOLD PLATING, BOX PACKAGING
2MM-HSP-S16-VT-02-H-BX

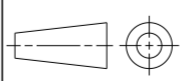
THIS DRAWING IS A CONTROLLED DOCUMENT.		DWN R R NAYAK 6APR2016	 TE Connectivity	
DIMENSIONS: mm		CHK KARTHIK J K 27JUN2016		
TOLERANCES UNLESS OTHERWISE SPECIFIED: 0 PLC ± 1 PLC ±0.1 2 PLC ±0.05 3 PLC ± 4 PLC ± ANGLES ±2°		APVD PRASHANTH S 27JUN2016	NAME AMPMODU 2mm SHROUDED MTE HEADER SINGLE ROW ,VERTICAL	
		PRODUCT SPEC 108-64040	SIZE A2	
MATERIAL SEE NOTES		APPLICATION SPEC 114-64040	CAGE CODE 00779	
FINISH SEE NOTES		WEIGHT	DRAWING NO C-2823174	
-		CUSTOMER DRAWING		RESTRICTED TO -
		SCALE 1:1	SHEET 2 OF 2	REV A