

REVISIONS			
REV	DESCRIPTION	DATE	APPV
A	PRODUCTION RELEASE	JHAGER 10/8/20	DV 3/1/21
B	ADJUSTED COUNTERPOISE SIZE PER DESIGN CHANGE. CHANGED DIMENSIONAL POINT ON U.FL CONNECTION. UNITS WAS INCHES PRIMARY. ADJUSTED TOLERANCES TO SUIT MFG CAPABILITY. ADDED MHF4 CAPABILITY.	JHAGER 5/7/21	
C	UPDATED DESIGN TO REDUCE TABULATION VARIABLES. DRWG WAS ANT-2.4-WRT-CCC	JHAGER 3/4/22	

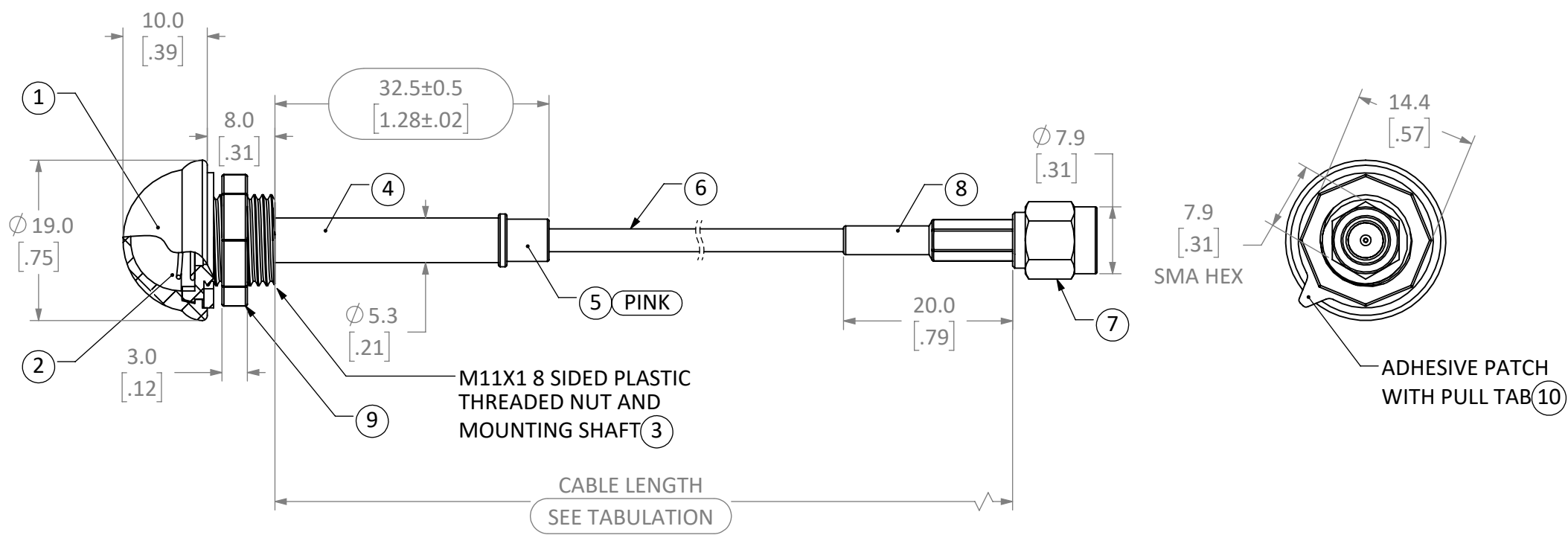

- NOTES: (UNLESS OTHERWISE SPECIFIED)
- ALL DIMENSIONS ARE IN MILLIMETERS [IN].
 - DIMENSIONS APPLY AFTER FINISHING.
 - MANUFACTURE TO BE COMPLIANT WITH EU RoHS DIRECTIVE, USE MATERIALS THAT DO NOT CONTAIN REACH SUBSTANCES OF VERY HIGH CONCERN >1000ppm, AND USE DRC CONFLICT-FREE SOURCED MATERIALS.
 - ELECTRICAL SPECIFICATIONS SHOWN FOR REFERENCE ONLY. REFER TO LINX DATA SHEET FOR ELECTRICAL PROPERTIES:
 - CENTER FREQUENCY 2.45 GHz
 - 50Ω IMPEDANCE
 - VSWR <1.9 TYP @ CENTER
 - ANTENNA QUALIFIED IAW LINX INTERNAL TEST PLAN DOCUMENT.
 - MECHANICAL:
 - USE TEMPERATURE: -40°C - +90°C
 - INSTALLATION TEMPERATURE: +10° - +40°C
 - STORAGE TEMPERATURE: +20° @ 50%RH
 - BULKHEAD PLASTIC NUT TORQUE: NTE 4.0kgf/cm [5in/lbS]
 - Ø.425" [10.8mm] RECOMMENDED INSTALL HOLE SIZE
 - MINIMUM BEND RADIUS: 10.2mm
 - MAX PANEL THICKNESS: 4.7mm [.188"]
 - INTERFACE COUPLES WITH STANDARD SMA TYPE REVERSE POLARITY CONNECTORS.
 - PACKAGE ANTENNAS INDIVIDUALLY PRIOR TO PLACING IN LOT BAG. LABEL LOT BAG, AND BOX WITH THE FOLLOWING INFORMATION ONLY:
 - LOT NUMBER
 - LINX PART NUMBER
 - QUANTITY
 - COUNTRY OF ORIGIN

ITEM NUMBER	DESCRIPTION
10	GASKET FOAM ADH ACRYLIC/ACRYLIC
9	NUT OCT M11X1 POM BLACK
8	SHRINK TUBE 2:1 POLYOL BLACK
7	CONNECTOR RP-SMA TYPE GOLD/BRASS
6	CABLE COAX RG174U BLACK
5	GUIDE CABLE 2.4GHz ABS PINK
4	COUNTERPOISE 2.4GHz ELEM NICKEL/BRASS
3	BASE THREADED M11X1 ABS BLACK
2	ELEMENT 2.4GHz COIL SWC
1	COVER ELEMENT ABS BLACK

WARNING: THIS DRAWING CONTAINS PROPRIETARY INFORMATION THAT IS THE SOLE PROPERTY OF LINX TECHNOLOGIES, AND SHALL BE TREATED AS SUCH. NO DISCLOSURE OR REPRODUCTION OF THIS DOCUMENT IS PERMITTED, IN WHOLE OR IN PART, WITHOUT THE EXPRESS WRITTEN PERMISSION OF LINX TECHNOLOGIES OR ITS DESIGNATED AGENTS.

MATERIAL: INTERPRET DIMENSIONS AND TOLERANCES PER ASME Y14.5.
 .X ±2.0 ANGLES: ±1°
 .XX ±1.00 SURFACE: √
 .XXX ±.500

PROJECTION:

FINISH: DRAWN: JHAGER DT: 10/8/20
 ENGR: DASARATHAN DT: 3/1/21

TITLE: **ANTENNA PURCHASED ASSEMBLY WRT VAR END CONN AND PACK**

SIZE DWG. NO. REV
B C-ANT-2.4-WRT-RPS-LLL **C**

SCALE: 1.5:1 DO NOT SCALE DRAWING SHEET 1 OF 1

STE 159 ORT LANE MERLIN, OR 97532
 connectivity

CABLE LENGTH TABULATION	
LINX PART NUMBER	CABLE LENGTH
ANT-2.4-WRT-RPS	216±2mm [8.50]