

REVISIONS			
REV	DESCRIPTION	DATE	APPV
A	PRODUCTION RELEASE	JHAGER 9/20/22	DV 9/23/22

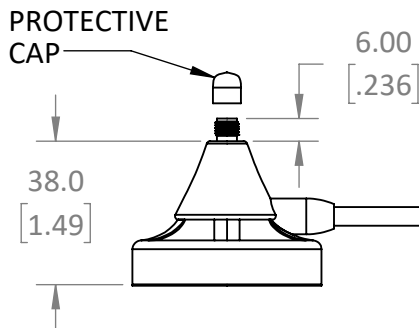
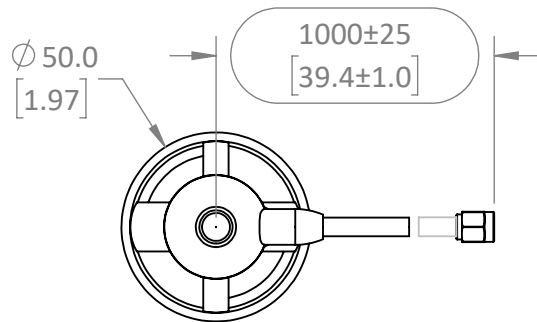
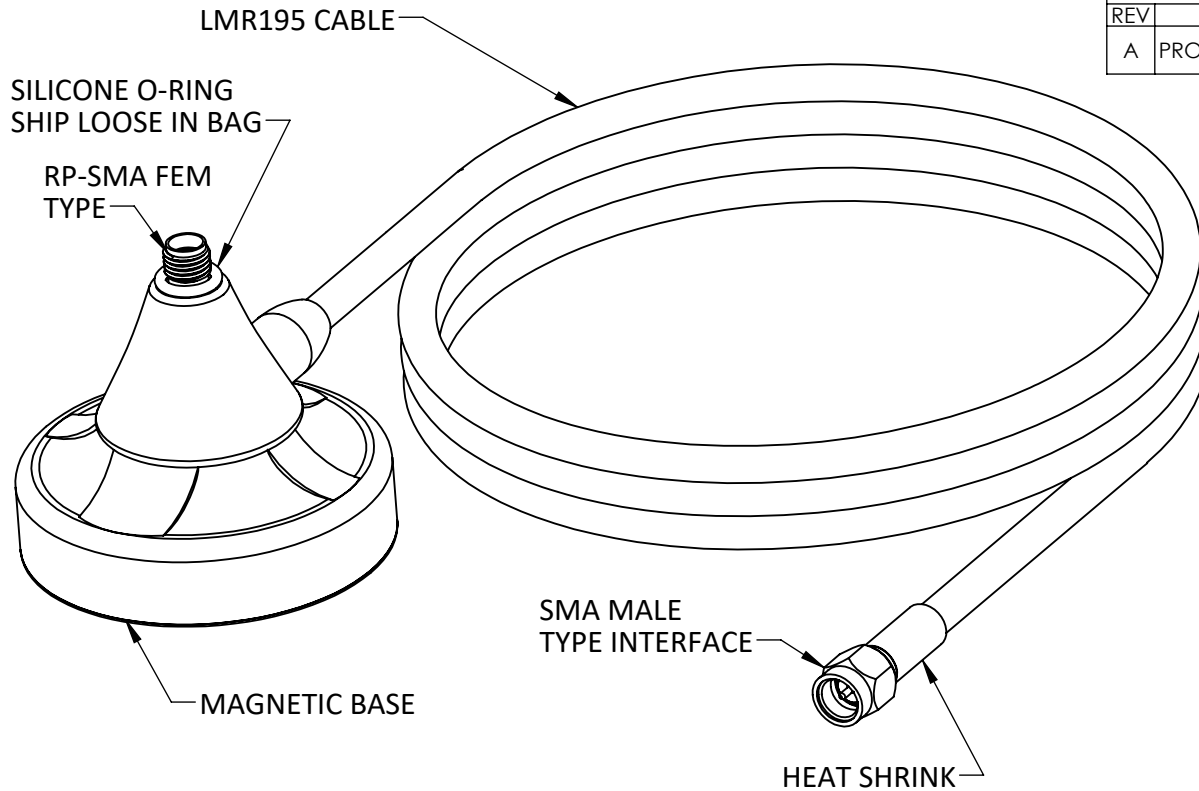

NOTES: (UNLESS OTHERWISE SPECIFIED)

1. ALL DIMENSIONS ARE IN MILLIMETERS [IN].
2. DIMENSIONS APPLY AFTER FINISHING.
3. MANUFACTURE TO BE COMPLIANT WITH EU RoHS DIRECTIVE, USE MATERIALS THAT DO NOT CONTAIN REACH SUBSTANCES OF VERY HIGH CONCERN >1000ppm, AND USE DRC CONFLICT-FREE SOURCED MATERIALS.
4. ELECTRICAL PROPERTIES SHOWN ARE FOR REFERENCE ONLY. REFER TO LINX DATA SHEET FOR COMPLETE SPECIFICATIONS.
 1. IMPEDANCE: 50Ω
 2. VSWR: NTE 2.0
 3. 7GHz MAX
5. PRODUCT QUALIFIED IAW LINX INTERNAL TEST PLAN AT LATEST REVISION.
6. MECHANICAL
 1. INTERFACE: SMA TYPE IAW MIL-STD-348B.
 2. INTERFACE: RP-SMA TYPE IAW [SPC-CON-IFS-RPS]
 3. OPERATING TEMPERATURE: -20°C - +60°C
 4. MINIMUM CABLE BEND RADIUS: 12.7mm
 5. BLACK PROTECTIVE PVC CAP FOR SMA THREAD PROTECTION DURING TRANSIT.
7. PACKAGE INDIVIDUALLY AND LABEL IAW LINX LABEL DRAWING PROVIDED.

WARNING: THIS DRAWING CONTAINS PROPRIETARY INFORMATION THAT IS THE SOLE PROPERTY OF LINX TECHNOLOGIES, AND SHALL BE TREATED AS SUCH. NO DISCLOSURE OR REPRODUCTION OF THIS DOCUMENT IS PERMITTED, IN WHOLE OR IN PART, WITHOUT THE EXPRESS WRITTEN PERMISSION OF LINX TECHNOLOGIES OR ITS DESIGNATED AGENTS.



159 ORT LANE
MERLIN, OR 97532

TITLE: ANTENNA EXTENDER SMA TYPE MAG MOUNT			
SIZE	DWG. NO.	REV	
A	C-ANT-MAG-RPSF-SMAM-1	A	
SCALE: 1:2	DO NOT SCALE DRAWING	SHEET 1 OF 1	

MATERIAL:	INTERPRET DIMENSIONS AND TOLERANCES PER ASME Y14.5.		PROJECTION:
PVC/PVCFLEX LMR195	X ±2.0 .XX ±1.00 .XXX ±.500	ANGLES: ±1° SURFACE: √	
FINISH:	DRAWN: JHAGER	DT: 9/20/22	
	ENGR: DASARATHAN	DT: 9/20/22	