

Connector: RP-SMA Jack (Male Pin)			
Termination: Bulkhead Front Mount			
Part Number		CONREVSMA004	CONREVSMA004-G
Connector Part	Material	Finish	Finish
Bodies	Body: Brass	Nickel	Gold
	Nut: Brass	Nickel	Gold
	Washer: Brass	Nickel	Gold
Center Contact	Pin: Brass	Gold	Gold
Insulator	PTFE	-	-

REVISIONS			
REV	DESCRIPTION	DATE	APPV
A	INITIAL RELEASE OF LINX INTERNAL DRAWING	01/MAR/19	CLL

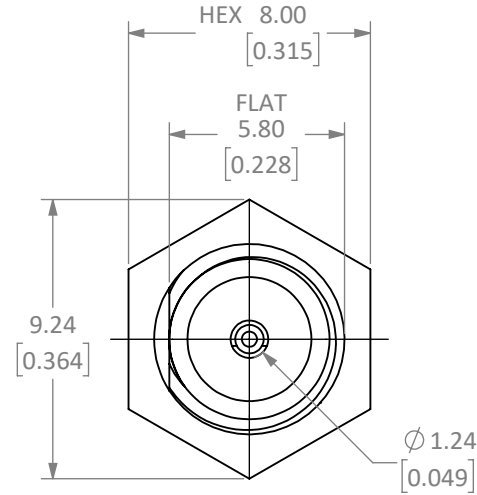
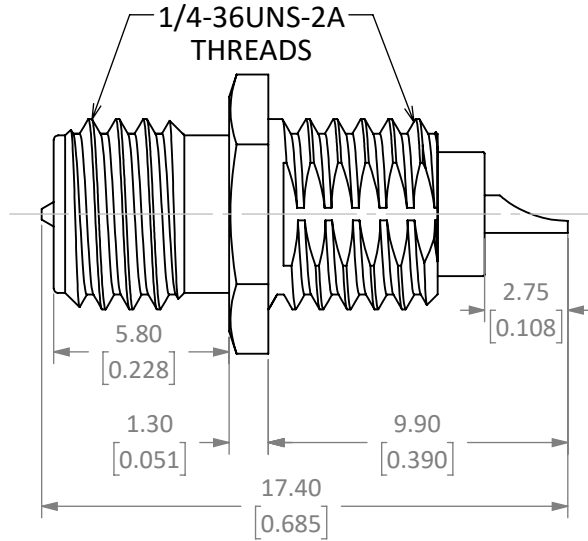

NOTES: (UNLESS OTHERWISE SPECIFIED)

1. ALL DIMENSIONS ARE IN mm [INCHES].
2. DIMENSIONS APPLY AFTER FINISHING.
3. MANUFACTURE TO BE COMPLIANT WITH EU RoHS DIRECTIVE, USE MATERIALS THAT DO NOT CONTAIN REACH SUBSTANCES OF VERY HIGH CONCERN >1000ppm, AND USE DRC CONFLICT-FREE SOURCED MATERIALS.
4. SAFETY BREAK ALL SHARP CORNERS AND EDGES 0.5 MAXIMUM.
5. SEE TABLE I FOR ELECTRICAL SPECIFICATIONS. (SHEET 2)
6. SEE TABLE II FOR ENVIRONMENTAL SPECIFICATIONS. (SHEET 2)
7. SEE TABLE III FOR MECHANICAL SPECIFICATIONS. (SHEET 2)
8. SEE PARTSLIST. "*" INDICATES FINISH TYPE.

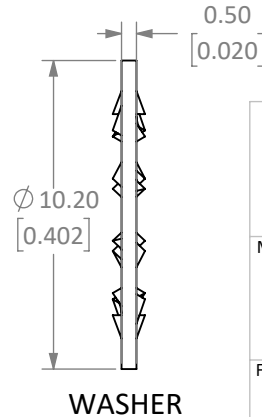
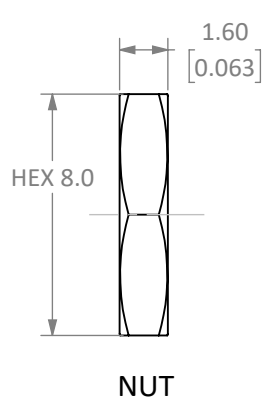

SCALE 1 : 1

WARNING: THIS DRAWING CONTAINS PROPRIETARY INFORMATION THAT IS THE SOLE PROPERTY OF LINX TECHNOLOGIES, AND SHALL BE TREATED AS SUCH. NO DISCLOSURE OR REPRODUCTION OF THIS DOCUMENT IS PERMITTED, IN WHOLE OR IN PART, WITHOUT THE EXPRESS WRITTEN PERMISSION OF LINX TECHNOLOGIES OR ITS DESIGNATED AGENTS.

MATERIAL:	INTERPRET DIMENSIONS AND TOLERANCES PER ASME Y14.5. X ±2.0 .XX ±1.00 .XXX ±.500	PROJECTION:	
FINISH:	DRAWN: M. SCHULTE DT: 21/JAN/19	ENGR: DASARATHAN DT: 08/MAR/19	



159 ORT LANE
MERLIN, OR 97532

TITLE: RP-SMA FEMALE BULKHEAD FRONT MOUNT W/SOLDER POT		
SIZE	DWG. NO.	REV
A	C-CONREVSMA004-p	A
SCALE: 4:1	DO NOT SCALE DRAWING	SHEET 1 OF 2

5 TABLE I

Electrical Data	Detail
Impedance	50 Ω
Frequency Range	0 to 6 GHz
Insulation Resistance	5 000 M Ω min.
Voltage Rating	1 000 V RMS
Contact Resistance	Center: \leq 3.0 m Ω Outer: \leq 2.5 m Ω

6 TABLE II

Environmental Data	Detail
Corrosion (Salt spray)	ASTM B-117
Thermal Shock	MIL-STD-202 Method 107 test condition B
Vibration	MIL-STD-202 Method 204 test condition D
Mechanical Shock	MIL-STD-202 Method 213 test condition I
Temperature Range	-55 $^{\circ}$ C to +155 $^{\circ}$ C
Environmental Compliance	RoHS

7 TABLE III

Mechanical Data	Detail
Mounting Type	Bulkhead Front Mount, Solder Pot
Fastening Type	1/4"-36 Threaded Coupling
Recommended Torque	0.57 N·m (5.0 in-lbs)
Coupling Nut Retention	60 lbs. min.
Connector Durability	500 cycles min.
Weight	2.6 g (0.1 oz)

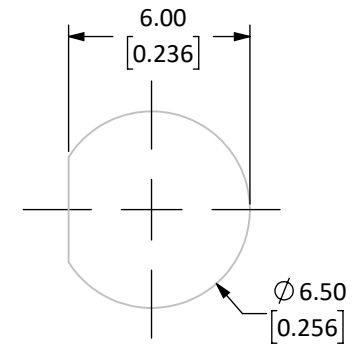

RECOMMENDED MOUNTING HOLE

SIZE	DWG. NO.	REV
A	CONREVSMA004-*	A
SCALE: 1:1	DO NOT SCALE DRAWING	SHEET 2 OF 2