

DATE CODE
 * * * * *
 M J Y mm DD

M: Assy inspection machine number
 J: Assy jig number
 Y: Year(Single-digit of year)
 m: Month(01->January)
 D: Date(01->1st)

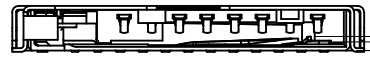

Defect: +0.06
 (0.3 -0.5)

Switch +0.06
 (0.4 -0.05)

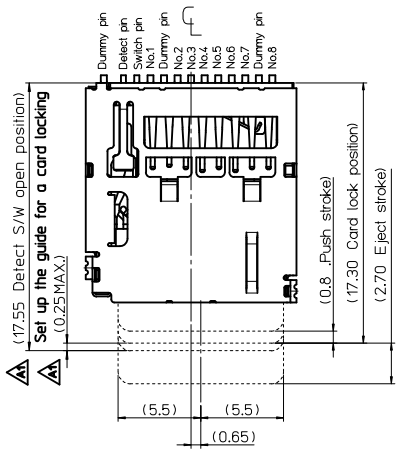

VIEW OF INSERTED CARD
 (SCALE 3:1)

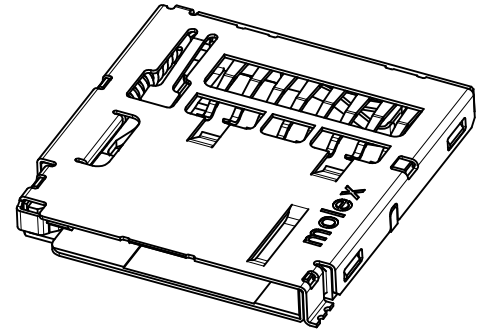
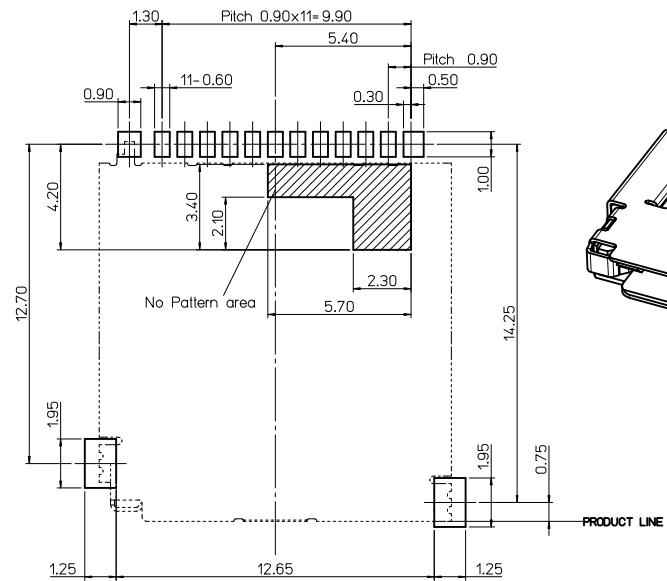
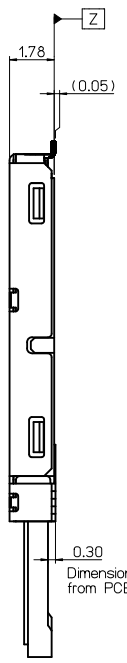

Card insertion condition	Card detect switch	Circuit
Without Card	Close	
Card insertion	Open	

NOTES

1. MATERIALS: SEE TABLE
2. FINISHES: SEE TABLE
3. PRODUCT SPECIFICATIONS: PS-104042-001
4. PACKING SPECIFICATIONS: PK-104042-001
5. COPLANARITY OF SOLDER TAILS: 0.1mm MAX. MISALIGNMENT OF SOLDER TAIL FROM 'Z' UPPER DIRECTION 0.05mm MAX., LOWER DIRECTION 0.1mm MAX.

NO.	PARTS NAME	MATERIALS	FINISHES
8	PIN ROD	STAINLESS STEEL	NONE
7	SLIDE CAM	THERMO PLASTIC	UL94V-0
6	SPRING	STAINLESS STEEL	NONE
5	SWITCH TERMINAL	PHOSPHOR BRONZE	SELECTIVE GOLD OVER NICKEL
4	DETECT TERMINAL	PHOSPHOR BRONZE	SELECTIVE GOLD OVER NICKEL
3	CONTACT TERMINALS	PHOSPHOR BRONZE	SELECTIVE GOLD OVER NICKEL
2	HOUSING	THERMO PLASTIC	UL94V-0
1	METAL SHELL	STAINLESS STEEL	SELECTIVE GOLD OVER NICKEL

REVISED EC NO: KOR2011-0088 DRWN: I CYANG 2011/04/06 CHKD: YS00KIM APPR: YUNSIKKIM 2011/04/06	QUALITY SYMBOLS ▽=0 ◻=0	1040420811	104042-0811
		MATERIAL NO.	ORDER NO.
		GENERAL TOLERANCES (UNLESS SPECIFIED)	
		DRAFT WHERE APPLICABLE MUST REMAIN WITHIN DIMENSIONS	

DIMENSION STYLE MM ONLY	SCALE 5/1	DESIGN UNITS METRIC	THIRD ANGLE PROJECTION
DRAWN BY I. C. YANG	DATE 2009.01.15	TITLE MICROSD SOCKET REVERSE PUSH-PUSH 1.78H	
CHECKED BY S. H. CHU	DATE 2009.01.15	APPROVED BY S. J. SEH 2009.01.15	
MATERIAL NO. SEE TABLE		DOCUMENT NO. SD-104042-001	
SIZE A3		THIS DRAWING CONTAINS INFORMATION THAT IS PROPRIETARY TO MOLEX INCORPORATED AND SHOULD NOT BE USED WITHOUT WRITTEN PERMISSION	

10 9 8 7 6 5 4 3 2 1

F

E

D

C

B

A

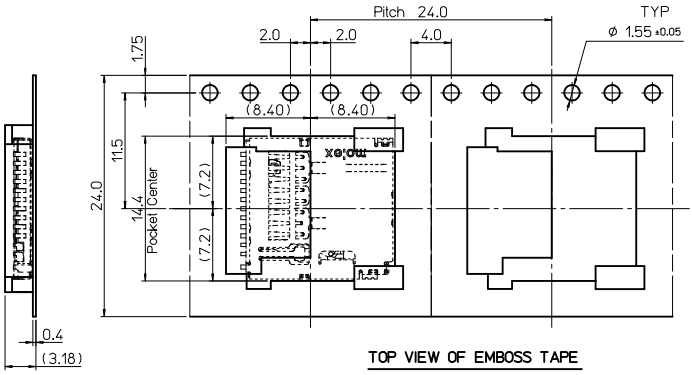

TOP VIEW OF EMOSS TAPE

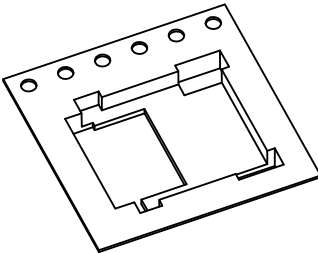

NOTES

- 1. QUANTITY OF PRODUCTS : 1,000 PCS / 1 REEL
- 2. LEAD LENGTH

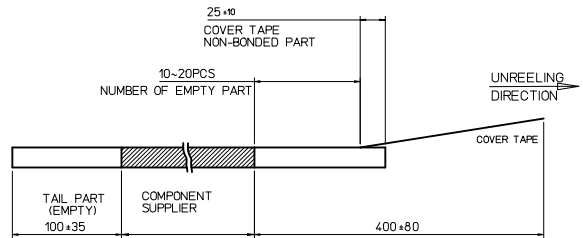

- 3. PEELING OFF FORCE OF COVER TAPE : 0.1N~0.59N(10.2~60gf)
(PEELING DIRECTION AS BELOW)
- PEELING OFF SPEED : 300mm/Min.(Ref.)

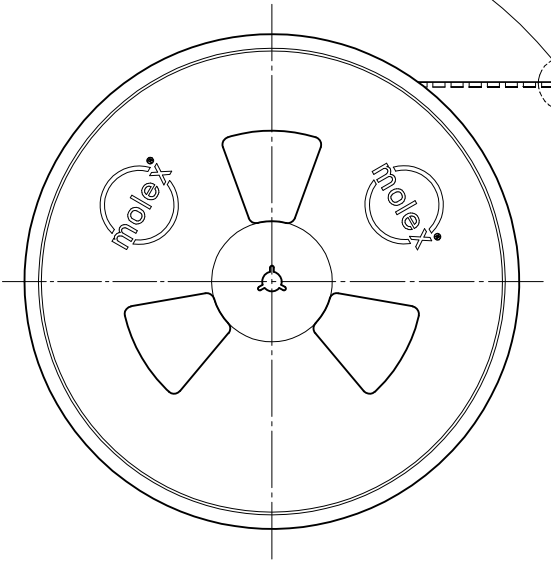
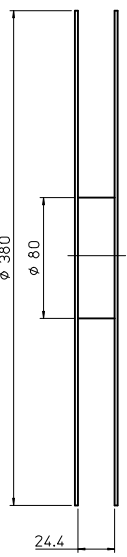
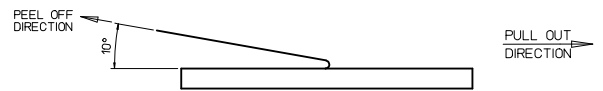

UNREELING OF PRODUCTS DIRECTION

REVISED EC NO: KOR2011-0088 DRWN: IYANG CHKD: YSOOKIM APPR: YUNSIKKIM 2011/04/06 2011/04/06	QUALITY SYMBOLS ▽=0 ◻=0	GENERAL TOLERANCES (UNLESS SPECIFIED)		DIMENSION STYLE MM ONLY		SCALE 2/1	DESIGN UNITS METRIC	THIRD ANGLE PROJECTION	
			4 PLACES ± --- ± --- 3 PLACES ± --- ± --- 2 PLACES ± 0.1 ± --- 1 PLACE ± 0.15 ± --- ANGULAR ± 1 °	mm INCH ± --- ± --- ± --- ± --- ± 0.1 ± --- ± 0.15 ± ---	DRAWN BY I . C . YANG 2009.01.15	DATE 2009.01.15	TITLE MICROSD SOCKET REVERSE PUSH-PUSH 1.78H		
			DRAFT WHERE APPLICABLE MUST REMAIN WITHIN DIMENSIONS		CHECKED BY S . H . CHU 2009.01.15	DATE 2009.01.15	MOLEX MOLEX INCORPORATED		
	A1	REV			APPROVED BY S . J . SEH 2009.01.15	DATE 2009.01.15	MATERIAL NO. SEE SHEET 1	DOCUMENT NO. SD-104042-001	SHEET NO. 2 OF 2

9 8 7 6 5 4 3 2 1