

| REVISIONS |                    |                    |                |
|-----------|--------------------|--------------------|----------------|
| REV       | DESCRIPTION        | DATE               | APPV           |
| A         | PRODUCTION RELEASE | JHAGER<br>10/20/20 | DV<br>10/26/20 |

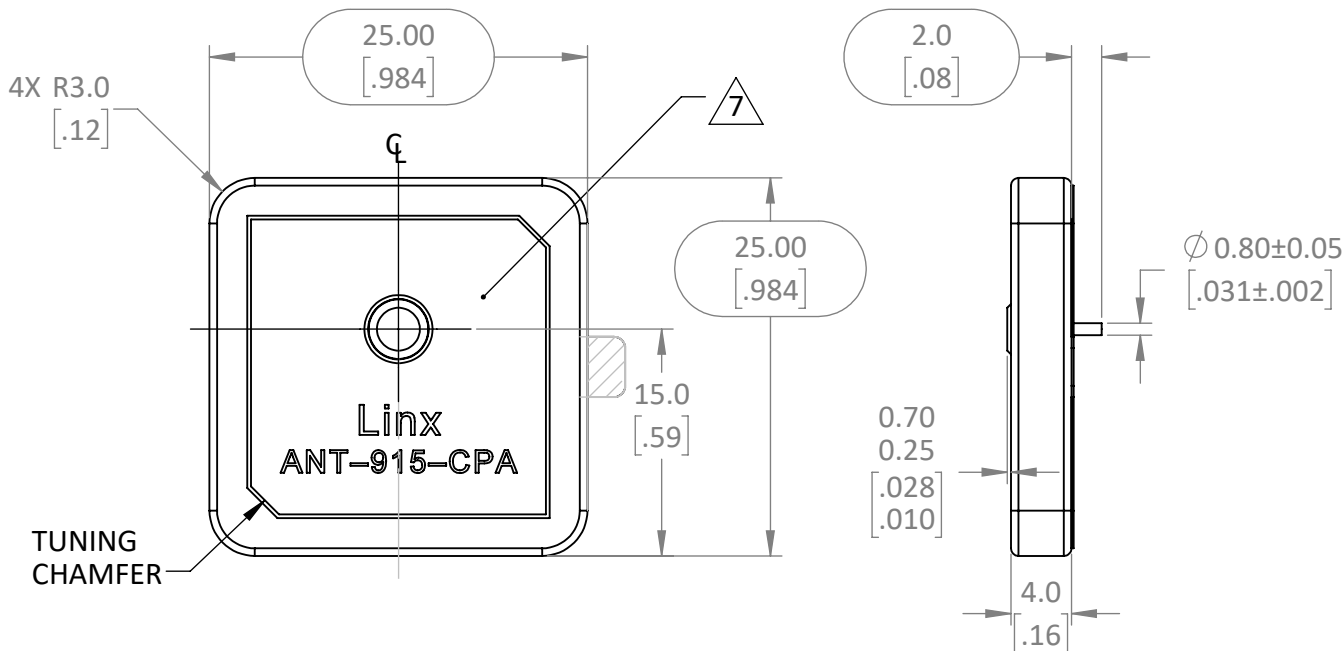

**NOTES: (UNLESS OTHERWISE SPECIFIED)**

- ALL DIMENSIONS ARE IN MILLIMETERS [in].
- DIMENSIONS APPLY AFTER FINISHING.
- MANUFACTURE TO BE COMPLIANT WITH EU RoHS DIRECTIVE, USE MATERIALS THAT DO NOT CONTAIN REACH SUBSTANCES OF VERY HIGH CONCERN >1000ppm, AND USE DRC CONFLICT-FREE SOURCED MATERIALS.
- SAFETY BREAK ALL SHARP CORNERS AND EDGES .02 MAXIMUM.
- ELECTRICAL SPECIFICATIONS SHOWN FOR REFERENCE ONLY. SEE LINX DATA SHEET FOR CURRENT PROPERTIES.
  - FREQ: 910MHz - 920MHz
  - VSWR: 1.2 MAX
  - IMPEDANCE: 50Ω

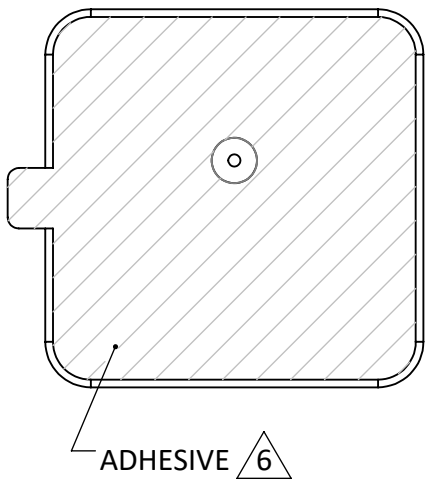

- ADHESIVE BACKED: NITTO: 5015 ACRYLIC ADHESIVE
  - APPLY BETWEEN 10°C - 40°C
  - REPOSITIONABLE
  - OPERATING TEMP: -40°C - 85°C

- LINK LOGO AND PART NUMBER TO BE PRINTED USING

- PACKAGE IN TRAY. LABEL TRAY AND BOX IAW LINX LABEL DRAWING [MEC-LBL-4x2.5-PAPER-ID]

**WARNING:** THIS DRAWING CONTAINS PROPRIETARY INFORMATION THAT IS THE SOLE PROPERTY OF LINX TECHNOLOGIES, AND SHALL BE TREATED AS SUCH. NO DISCLOSURE OR REPRODUCTION OF THIS DOCUMENT IS PERMITTED, IN WHOLE OR IN PART, WITHOUT THE EXPRESS WRITTEN PERMISSION OF LINX TECHNOLOGIES OR ITS DESIGNATED AGENTS.



159 ORT LANE  
MERLIN, OR 97532

TITLE:  
**915 MHz Ceramic Patch  
Antenna 40 mm square RHCP**

|                      |   |              |                 |          |                      |              |
|----------------------|---|--------------|-----------------|----------|----------------------|--------------|
| MATERIAL:<br>CERAMIC | INTERPRET DIMENSIONS AND TOLERANCES PER ASME Y14.5. |              | PROJECTION:<br> | SIZE     | DWG. NO.             | REV          |
|                      | .X ±2.0   | ANGLES: ±1°  |                 | <b>A</b> | C-ANT-915-CPA        | <b>A</b>     |
| FINISH:              | DRAWN: JHAGER                                       | DT: 10/20/20 | SCALE: 2:1      |          | DO NOT SCALE DRAWING | SHEET 1 OF 1 |
|                      | ENGR: DASARATHAN                                    | DT:          |                 |          |                      |              |