

REVISIONS			
REV	DESCRIPTION	DATE	APPV
A	PRODUCTION RELEASE	JHAGER 9/20/20	

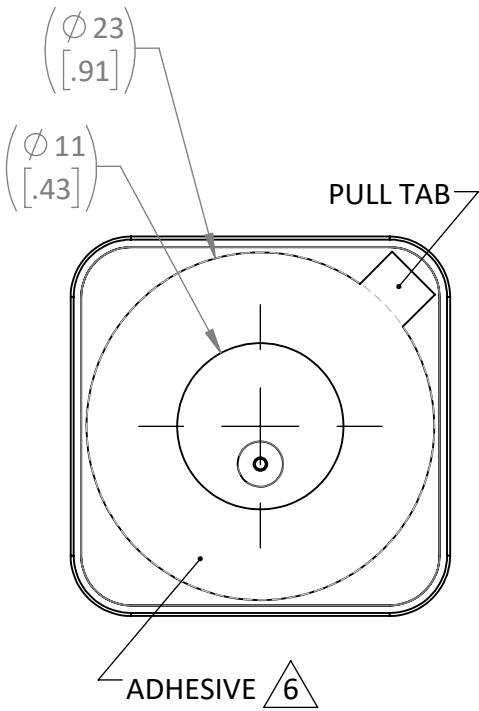
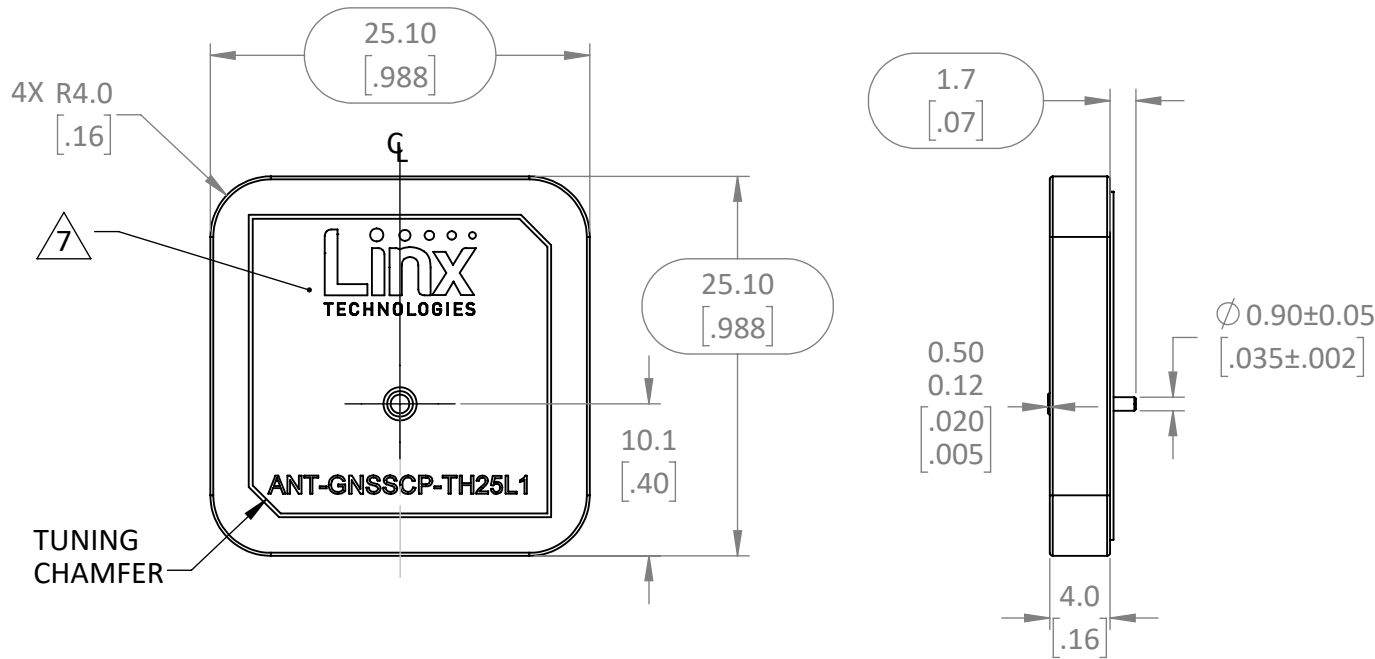

NOTES: (UNLESS OTHERWISE SPECIFIED)

- ALL DIMENSIONS ARE IN MILLIMETERS [in].
- DIMENSIONS APPLY AFTER FINISHING.
- MANUFACTURE TO BE COMPLIANT WITH EU RoHS DIRECTIVE, USE MATERIALS THAT DO NOT CONTAIN REACH SUBSTANCES OF VERY HIGH CONCERN >1000ppm, AND USE DRC CONFLICT-FREE SOURCED MATERIALS.
- SAFETY BREAK ALL SHARP CORNERS AND EDGES .02 MAXIMUM.
- ANTENNA: CERAMIC PATCH
 - FREQ: 1561MHz - 1602MHz
 - VSWR: 1.8 MAX
- ADHESIVE BACKED: NITTO: 5015 ACRYLIC ADHESIVE
 - APPLY BETWEEN 10°C - 40°C
 - HIGH SURFACE ENERGY PLASTICS
 - TEMPERATURE RANGE: -40°C - +70°C
 - REMOVE OIL, MOISTURE AND DIRT USING ISOPROPYL ALCOHOL. PRESS TO CLEAN SURFACE FIRMLY TO APPLY PRESSURE [4LB] TO ANTENNA FOR 5 SECONDS.
 - ADHESION STRENGTH [70%@30MIN] [90%@24HR]
- LINK LOGO AND PART NUMBER TO BE PRINTED USING BLACK EPOXY INK AS SHOWN.
- LABEL TRAY AND BOX PACKAGING IAW LINX LABEL DRAWING [MEC-LBL-4x2.5-PAPER-ID]

WARNING: THIS DRAWING CONTAINS PROPRIETARY INFORMATION THAT IS THE SOLE PROPERTY OF LINX TECHNOLOGIES, AND SHALL BE TREATED AS SUCH. NO DISCLOSURE OR REPRODUCTION OF THIS DOCUMENT IS PERMITTED, IN WHOLE OR IN PART, WITHOUT THE EXPRESS WRITTEN PERMISSION OF LINX TECHNOLOGIES OR ITS DESIGNATED AGENTS.



159 ORT LANE
MERLIN, OR 97532

TITLE:
ANT GNSS L1 TH CPA 25X25

MATERIAL:	INTERPRET DIMENSIONS AND TOLERANCES PER ASME Y14.5.	PROJECTION: 	SIZE	DWG. NO.	REV
	.X ±2.0 ANGLES: ±1° .XX ±1.00 SURFACE: $\sqrt{\text{ }}$.XXX ±.500		A	C-ANT-GNSSCP-TH25L1	A
FINISH:	DRAWN: JHAGER	DT: 09/20/20	SCALE: 2:1	DO NOT SCALE DRAWING	SHEET 1 OF 1
	ENGR:	DT:			