

2208855-1
COMPLETELY CLOSED

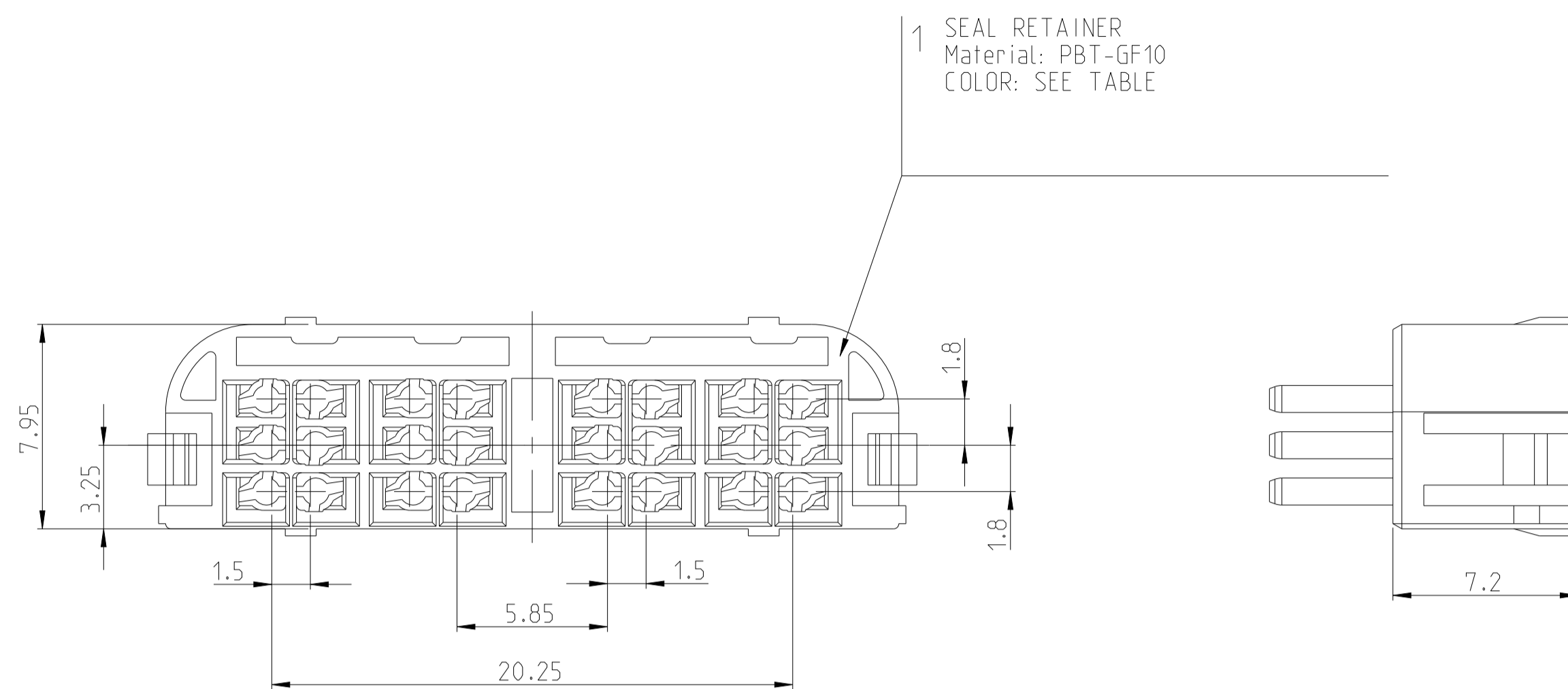

1 SEAL RETAINER
Material: PBT-GF10
COLOR: SEE TABLE

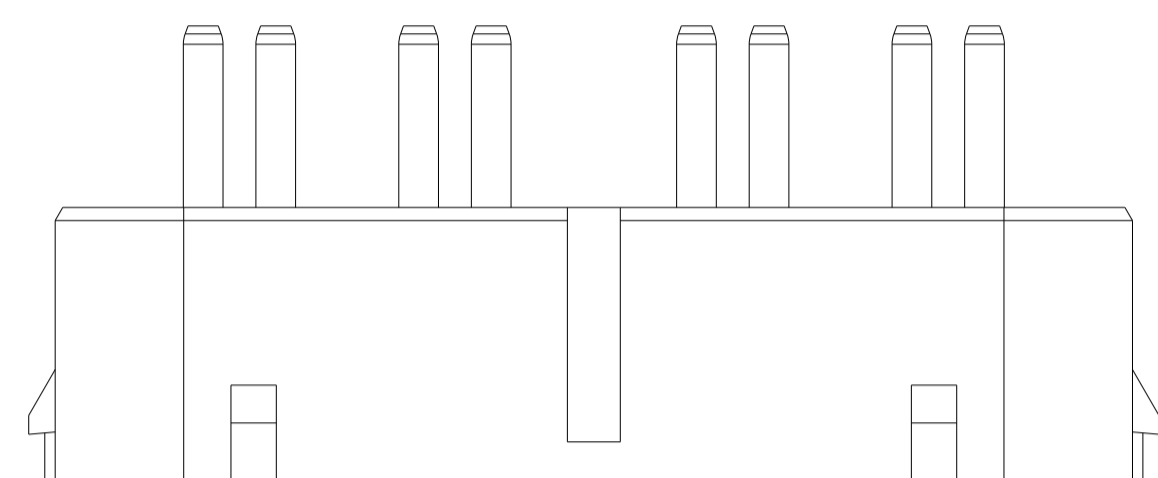
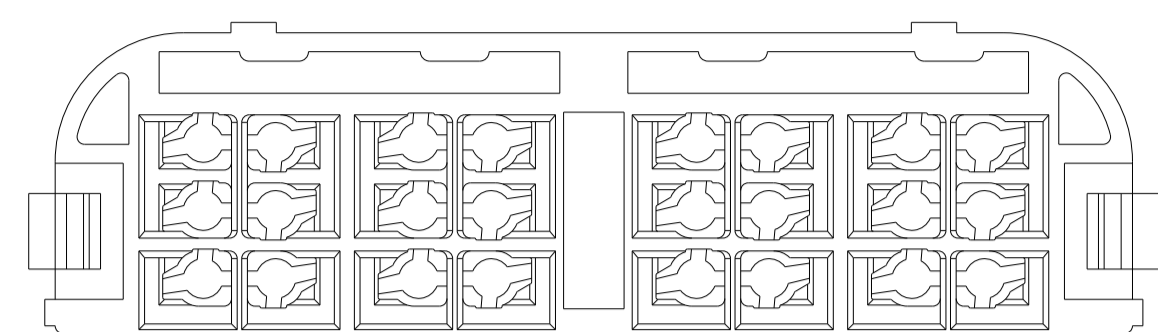
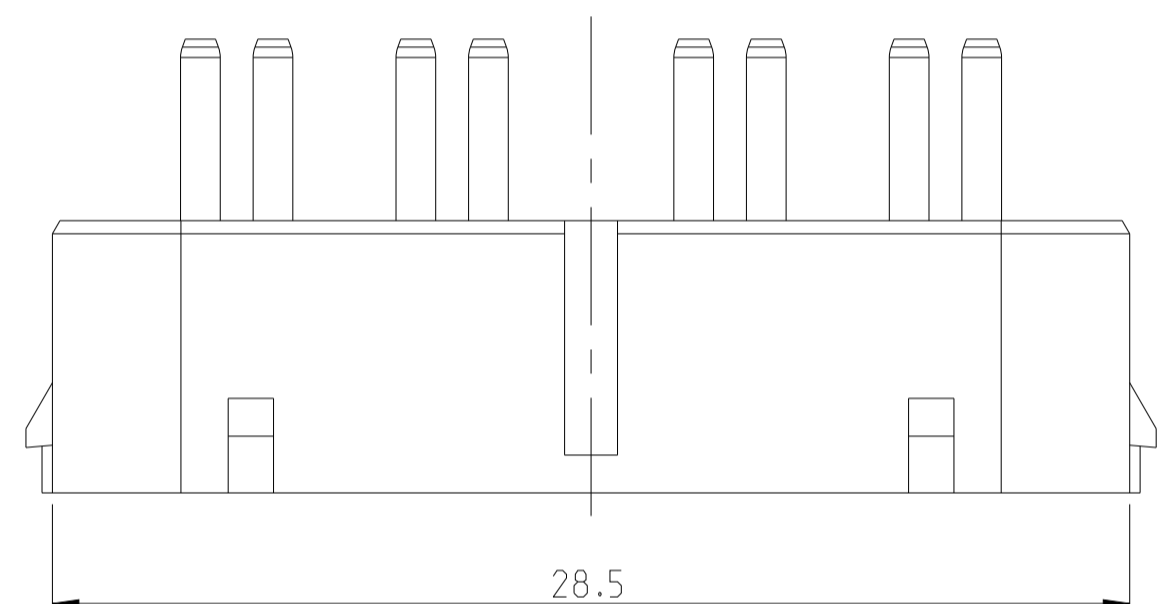

NOTES

- 1 FIELD OF APPLICATION SEE DRAWING TE: 2314052
 - 2 CHANGES ONLY WITH APPROVAL OF THE RESPONSIBLE DEPARTMENT
 - 3 THE MANUFACTURER CAN CHANGE DETAILS OF THE DESIGN
 - 4 TESTING ACCORDING TO TEAM TEST GUIDELINE FOR MOTOR VEHICLE CONNECTORS LV 214 DETAILS SEE TEST REPORT
 - 5 PART LINE PERMITTED MAX. 0.3
 - 6 SPLIT LINE PERMITTED MAX. 0.3
 - 7 PACKAGING: ACC. TO TE PACKAGING INSTRUCTION V2208855
 - 8 RECYCLED MATERIAL PERMISSIBLE MAX. 25%
 - 9 SUPPLIER LOGO VERSION OPTIONAL
 - 10 PRESSURE MARK OR SLIGHT DAMAGE OF PLASTIC WITHOUT FUNCTIONAL EFFECT ON THE COUNTER PART ARE PERMITTED
 - 11 SLIGHT DIFFERENCES IN RAL-COLOUR WITHIN THE BASE-COLOUR AND LOCAL COLOUR DIFFERENCES (COLOUR INCLUSIONS) OF THE PART ARE PERMITTED
- 1 AS SHOWN

REVISIONS				
P	LTH	DESCRIPTION	DATE	APVD
A		NEW DRAWING	10NOV2021	VKS PT

1:1

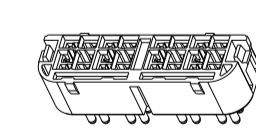

2208855-1	B	CLOSED	BLACK	1.4	2314052	SOCKET HOUSING 32 POS.
TE PART NO.	REV.	VERSION	SURFACE COLOUR	WEIGHT (G)	TE DRAWING NO.	SUITABLE FOR

TOLERANCING EN ISO 8015 TOLERIERUNG EN ISO 8015		TOLERANCING EN ISO 8015 TOLERIERUNG EN ISO 8015	
<small>TOLERANCES UNLESS OTHERWISE SPECIFIED ACC. TO DIN 16901-140@CENTRIC TO NOMINAL DIMENSION, EDITION 1982-11 SHALL APPLY. Freimaßtoleranzen nach DIN 16901-140@. Es gilt die Ausgabe 1982-11.</small>			
<small>THIS DRAWING IS A CONTROLLED DOCUMENT.</small> DIMENSIONING AND TOLERANCING PER GPS (ISO STANDARDS)		DWN: VINOTH KUMAR S CHK: PARUSURAM T 10NOV2021 10NOV2021	
DIMENSIONS: mm 		TOLERANCES UNLESS OTHERWISE SPECIFIED: 0 PLC ± 1 PLC ± 2 PLC ± 3 PLC ± 4 PLC ± ANGLES ±1° FINISH	
MATERIAL: - FINISH: -		NAME: SEAL RETAINER PRODUCT SPEC: - APPLICATION SPEC: 116-94200 WEIGHT: - CUSTOMER DRAWING	
SIZE: A CAGE CODE: 00779 DRAWING NO: 2208855		RESTRICTED TO: - SCALE: 5:1 SHEET: 1 OF 1 REV: A	