

6

5

4

3

2

1

REVISIONS					
REV.	ECN#	ZONE	DESCRIPTION	CHANGED BY/DATE	APPROVED BY/DATE
F01	ECN-IAS-03731		PRODUCTION RELEASE	WT NG 27FEB15	HANG 27FEB15

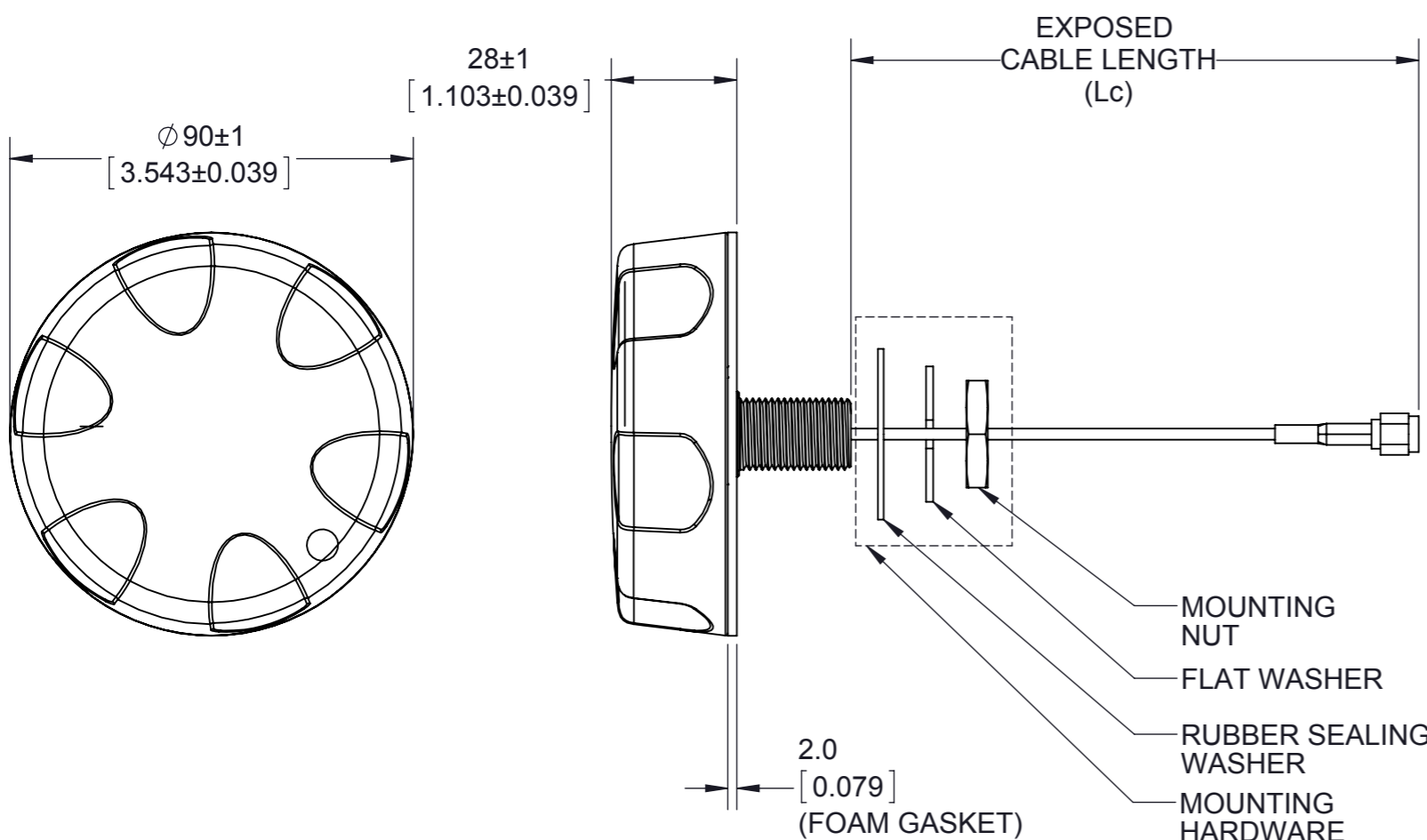

Parameter	Performance			
Model Number	LPS88213NT-61SMAM			
RF Connector	SMA Male Connector			
Cable Type	RG 316			
Cable Length, Lc	610 ± 12mm [24" ± 0.47"]			
Frequency (MHz)	880-960	1710-1880	1850-1990	1910-2170
Gain dBi, Typ				
On Metal Housing	2.2	4.4	3.7	3.7
On Plastic Housing	2.3	1.8	2.1	2.9
Gain dBi, Max				
On Metal Housing	2.5	5	3.9	3.9
On Plastic Housing	3.4	2.1	2.5	3
VSWR	3.0:1 Max.			
Nominal Impedance	50Ω			
Power (Watts)	10W Max.			
Azimuth beam width	Omnidirectional			
Polarization	Linear Vertical			
Dimension	26(H)X90(Dia.)mm (Excludes Gasket Height)			
Weight lbs (kg)	Approximate 108.5g [0.24lb]			
Storage Temp Range (°C)	-40°C to 85°C			
Operator Temp Range (°C)	-30°C to 70°C			
Outdoor Rated	Yes			
IP Rating	IP67			
Wind Survival	200 km/h [119.9Mph]			
Mounting	Bulkhead			
Mounting Nut Installation Torque	5.43~8.14 Nm			
Radome	PC, Black			
Material Substance Compliance	RoHS Compliant			

Note:  
 -Antenna is ground independent but its antenna performance may change according to customer test condition.  
 -Metal housing and Plastic housing test condition are represented by 300mm diameter aluminium plate and 255mm x 255mm x 2mm plastic base respectively.  
 -Patent Pending.

A

The component(s), including any plating, finishes, coatings, chemicals and surfaces treatments, supplied in this document/drawing must conform and comply with the latest issue of Laird Technologies Specification LT-GES-001, which fully includes but is not limited to all contents of EU Directives 2011/65/EC (RoHS Directive), as well as includes requirements of the Joint Industry Guide standard JIG-101, April 2005. The component(s) in this document/drawing may be subject to a full compound analysis for proof of compliance. The latest issue of Laird Technologies Specification LT-GES-001, (General Specification for the Environment) is readily available upon request from the supplier.

UNLESS OTHERWISE NOTED, THIS DOCUMENT CONTAINS LAIRD TECHNOLOGIES CONFIDENTIAL INFORMATION. REPRODUCTION, USE, DISCLOSURE OR TRANSMITTAL OF ALL OR ANY PART OF THIS DOCUMENT IS PROHIBITED EXCEPT TO THE EXTENT APPROVED IN WRITING BY AN AUTHORIZED REPRESENTATIVE OF LAIRD TECHNOLOGIES. LAIRD TECHNOLOGIES RESERVES ALL RIGHTS UNDER PATENTS, TRADEMARKS, COPYRIGHTS AND TRADE SECRETS. COPYRIGHT, LAIRD TECHNOLOGIES 2014. ALL RIGHTS RESERVED.

<b>MATERIAL:</b> N/A		THIRD ANGLE PROJECTION		 IAS, PENANG MALAYSIA	
<b>FINISH:</b> N/A		DO NOT SCALE DRAWING			
APPROVALS		DATE		TITLE:	
DRAWN BY	WT NG	27JAN15		<b>MOUNTING &amp; OUTLINE</b> <b>LPS88213NT-61SMAM</b>	
ELEC. ENG.	XW TEOH	27JAN15			
MECH. ENG.	WT NG	27JAN15			
MFG./OPS.	SC NG	27JAN15			
INTERPRET DIMENSIONING AND TOLERANCING IN ACCORDANCE WITH ASME Y14.5M-2009		TOLERANCES UNLESS OTHERWISE SPECIFIED		SIZE	
DIMENSIONS ARE IN MILLIMETERS		ANGLE: ±30'		DWG. NO.	
0 PLACE DECIMAL: ±0.5		1 PLACE DECIMAL: ±0.25		<b>A3LPS88213NT-61SMAMMO F01</b>	
2 PLACE DECIMAL: ±0.13		SURFACE ROUGHNESS 1.6/√			
SCALE: 2:3		PREVIOUS#		REV	
				SHEET 1 OF 1	

6

5

4

3

2

1