

P	LTR	DESCRIPTION	DATE	DWN	APVD
1		NEW RELEASE	07 JUL 2023	MM	MM
2		CORRECTION	28 JUL 2023	MM	MM

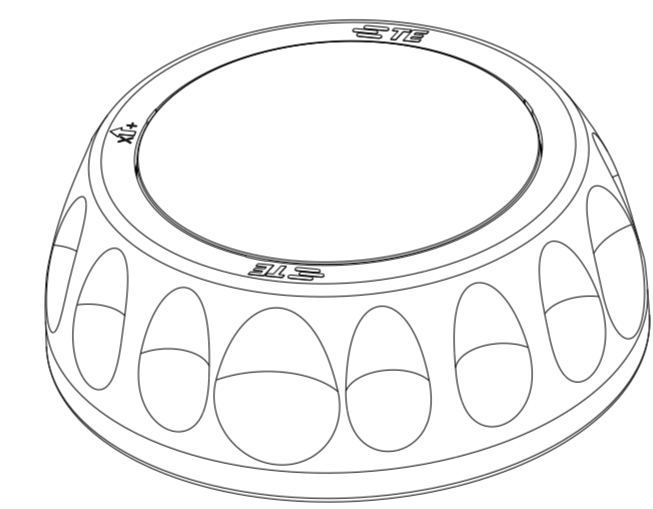

SCALE 1:1

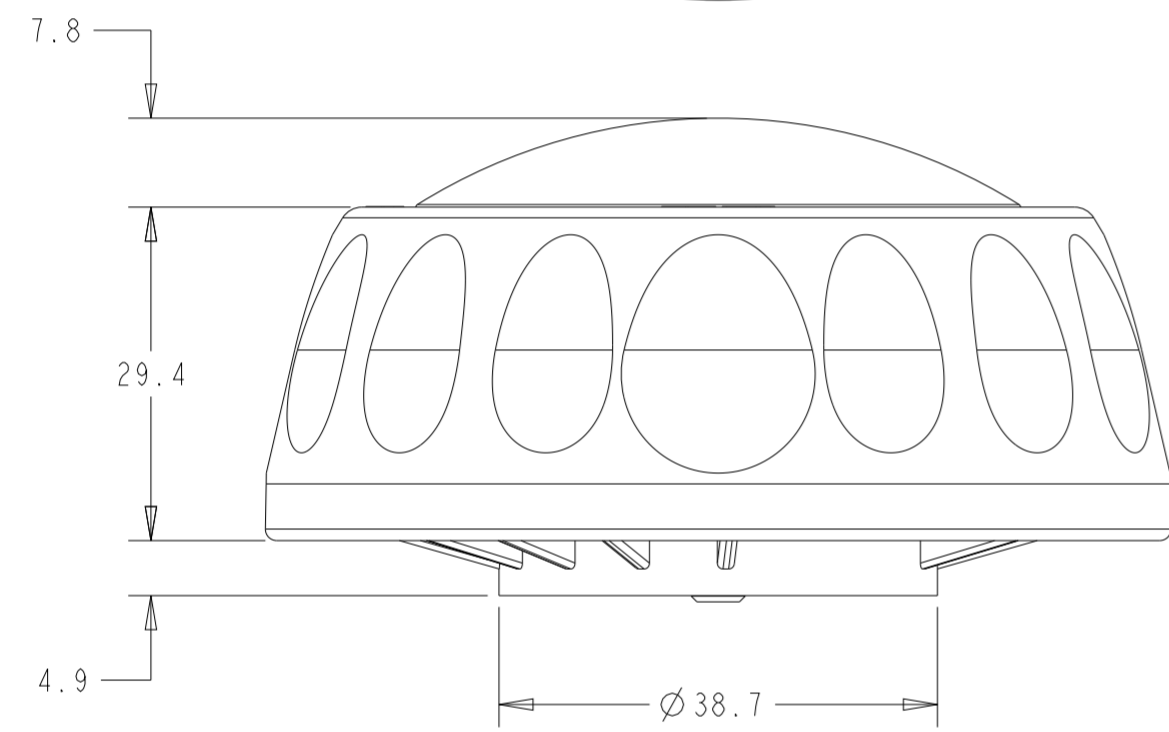
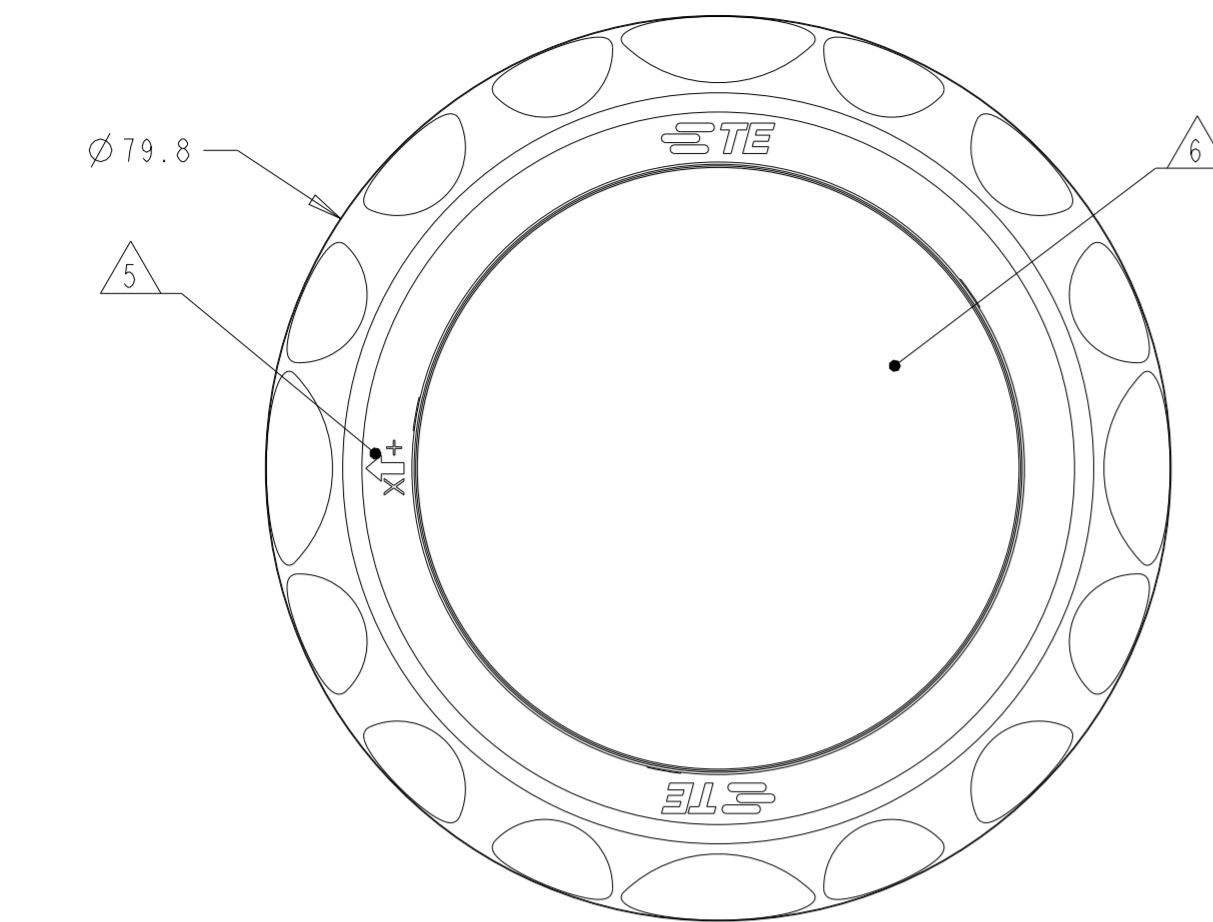
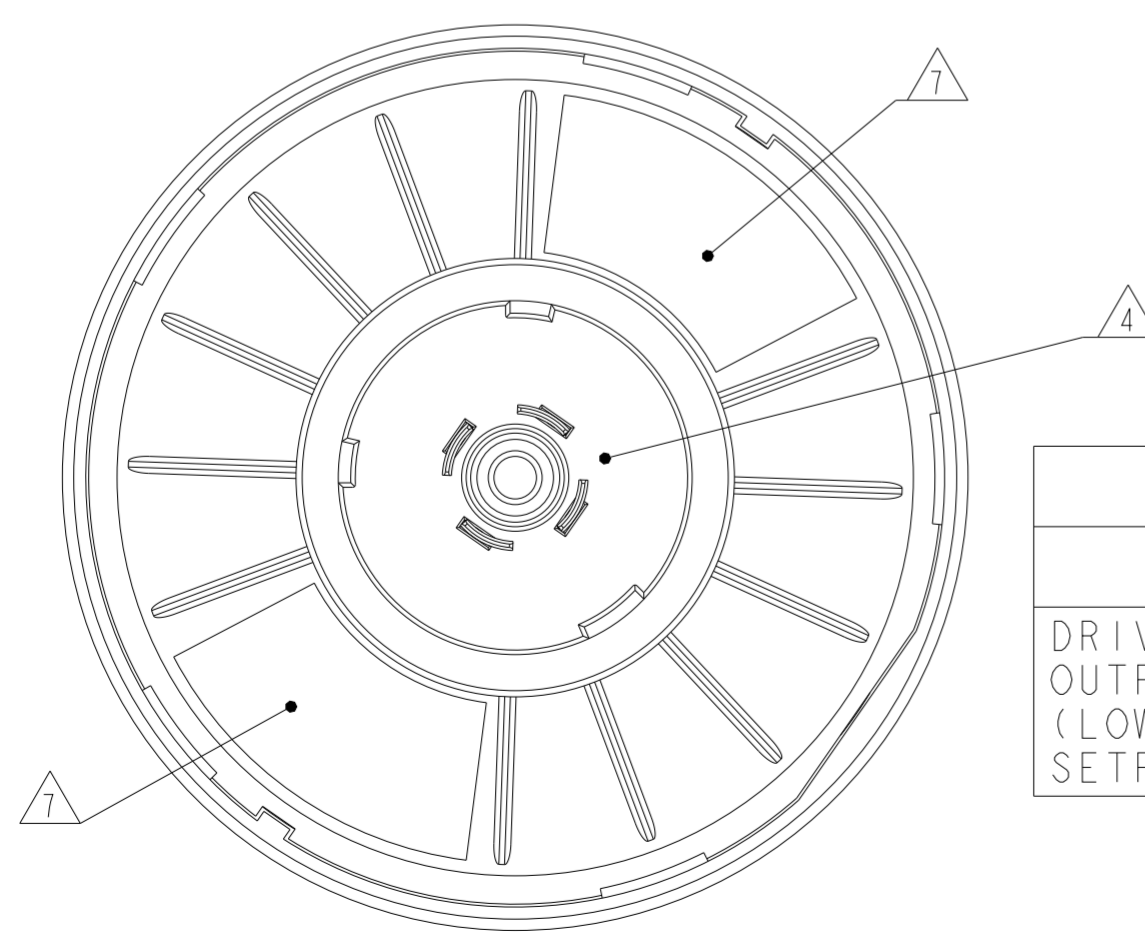

NOTES:

- 1 MATERIALS AND FINISH:
 -HOUSING: PC, COLOR: DARK GREY
 -LOCKING RING: PBT, COLOR: DARK GREY
 -MODULE BASE: PBT, COLOR: GREY
 -LENS: PE
 -GASKET: LSR
 -CONTACTS: BRASS, FINISH: Sn
 -PCBA: FR4
- 2. MUST COMPLY WITH DIRECTIVE 2011/65/EC (ROHS2)
- 3. THIS PRODUCT HAS NOT COMPLETED VALIDATION TESTING
- 4 MATES WITH ZHAGA BOOK 18 RECEPTACLES, SEE TE LUMAWISE ENDURANCE S/S2; P/N: 2213858-X, 2363638-X
- 5 ZHAGA BOOK 18 X+ AXIS DIRECTION MARKING
- 6 DETECTION ZONE MASK AVAILABLE; TE P/N: 2396399-1
- 7 PRODUCT IDENTIFICATION LABELS
- 8 FACTORY PROGRAMMED LEVELS. PARAMETERS ARE ADJUSTABLE BY UTILIZING THE DALI PARAMETERS AS NOTED IN 114-160511 APPLICATION SPECIFICATION.

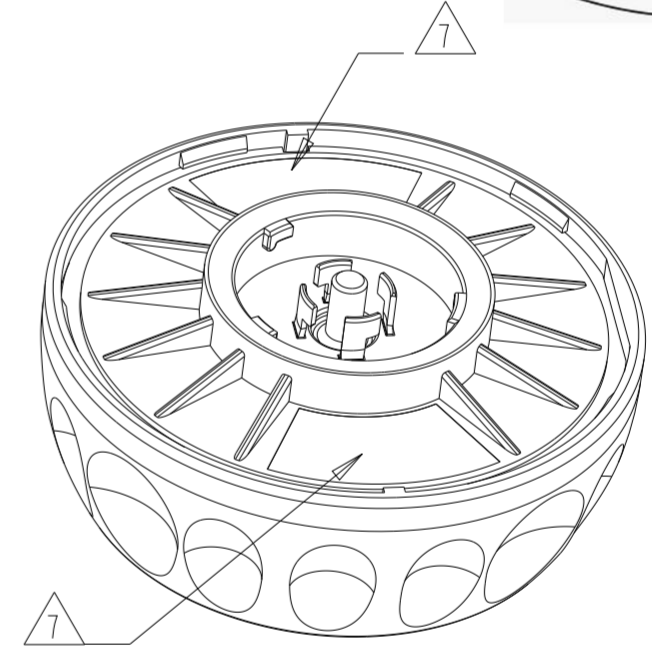
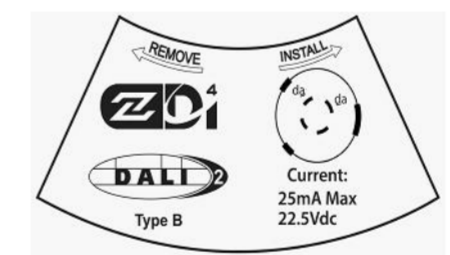
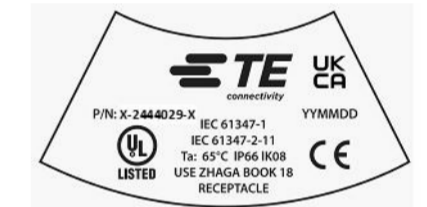

20	100	50	18	35	120	CIRCULAR	3-2444029-1
20	100	50	18	35	120	RECTANGULAR	2444029-1
DRIVER OUTPUT % (LOW SETPOINT) 8	DRIVER OUTPUT % (HIGH SETPOINT) 8	DRIVER OUTPUT % (EMERGENCY SETPOINT) 8	LIGHT LEVEL TURN OFF THRESHOLD (LUX) 8	LIGHT LEVEL TURN ON THRESHOLD (LUX) 8	LAMP ON TIME (SECONDS) 8	DETECTION PATTERN	PART NO.

THIS PRINT IS
PRELIMINARY
 UNQUALIFIED PRODUCT
 CONTACT PRODUCT ENGINEERING
 BEFORE USING THIS PRINT

THIS DRAWING IS A CONTROLLED DOCUMENT.

DWN	M. MOSTOLLER	07 JUL 2023
CHK	M. MOSTOLLER	07 JUL 2023
APVD	M. MOSTOLLER	

STE TE Connectivity

NAME: ASSEMBLY, STREETLIGHT PROGRAMMABLE MOTION SENSOR

PRODUCT SPEC	108-160457
APPLICATION SPEC	114-160511
WEIGHT	-

SIZE	A2	CAGE CODE	00779	DRAWING NO.	C-2444029	RESTRICTED TO	-
CUSTOMER DRAWING	SCALE	3:2	SHEET	1 OF 1	REV	2	