

THIS DRAWING IS A CONTROLLED DOCUMENT  
DWG NO ANT-418-WRT-RPS-LLL

REVISIONS			
REV	DESCRIPTION	DATE	APPV
A	PRODUCTION RELEASE	JHAGER 10/18/20	DV 1/3/21
B	UPDATED CABLE LENGTH TOLERANCE WAS ±1mm	JHAGER 10/29/21	DV
C	UPDATED DRAWING TO REDUCE TABULATED VARIABLES. DRAWING WAS ANT-FFF-WRT-CCC	JHAGER 3/8/22	DV

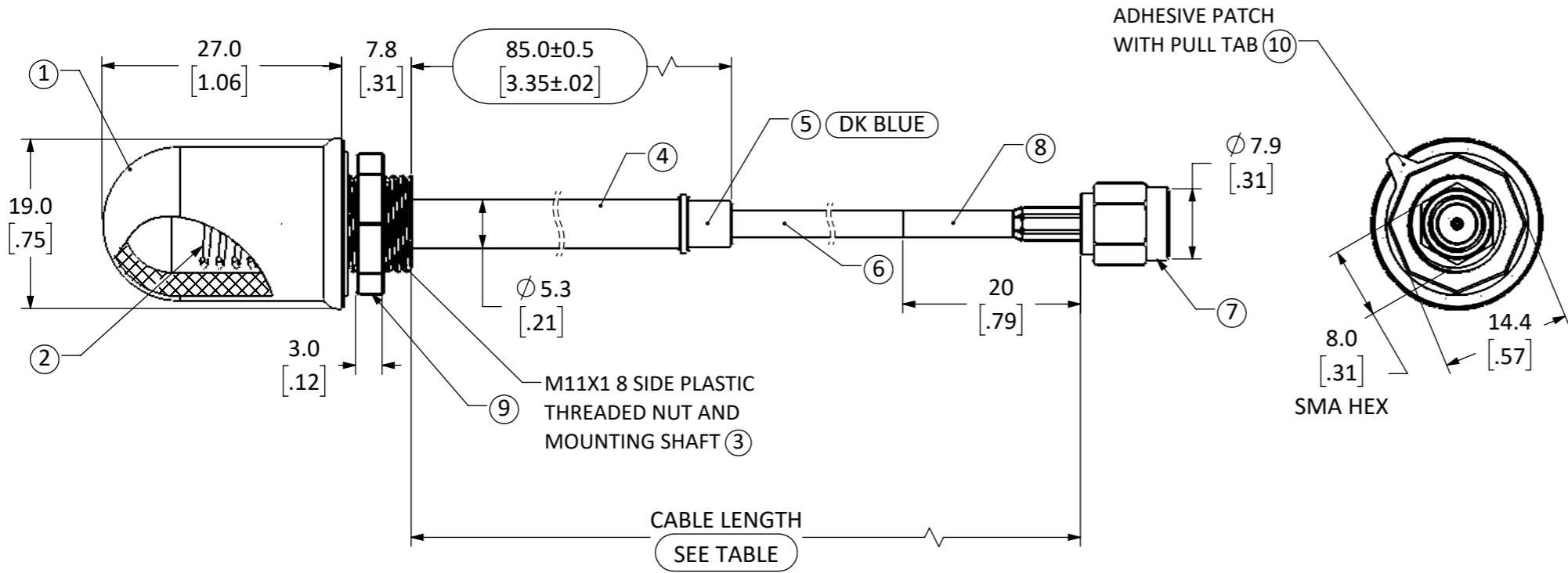

- NOTES: (UNLESS OTHERWISE SPECIFIED)
- ALL DIMENSIONS ARE IN MILLIMETERS [in].
  - DIMENSIONS APPLY AFTER FINISHING.
  - MANUFACTURE TO BE COMPLIANT WITH EU RoHS DIRECTIVE, USE MATERIALS THAT DO NOT CONTAIN REACH SUBSTANCES OF VERY HIGH CONCERN >1000ppm, AND USE DRC CONFLICT-FREE SOURCED MATERIALS.
  - PACKAGE ANTENNAS INDIVIDUALLY PRIOR TO PLACING IN LOT BAG. LABEL LOT BAG, AND BOX WITH THE FOLLOWING INFORMATION ONLY:
    - LOT NUMBER
    - LINX PART NUMBER
    - QUANTITY
    - COUNTRY OF ORIGIN
  - ANTENNA QUALIFIED AND TESTED IAW LINX INTERNAL TEST PLAN DOCUMENT AT LATEST REVISION.
  - ELECTRICAL DATA SHOWN FOR REFERENCE ONLY. SEE LINX DATA SHEET FOR COMPLETE ELECTRICAL PROPERTIES:
    - CENTER FREQUENCY 433MHz
    - 50Ω IMPEDANCE
    - VSWR <1.9 TYP @ CENTER
  - MECHANICAL:
    - USE TEMPERATURE: -40°C - +90°C
    - INSTALLATION TEMPERATURE: +10° - +40°C
    - STORAGE TEMPERATURE: +20° @ 50%RH
    - BULKHEAD PLASTIC NUT TORQUE: NTE 4.0kgf/cm [5in/lbS]
    - Ø.425" [10.8mm] RECOMMENDED INSTALL HOLE SIZE
    - MINIMUM BEND RADIUS: 10.2mm
    - MAX PANEL THICKNESS: 4.7mm [.188"]
    - CONNECTION: REVERSE POLARITY SMA TYPE INTENDED TO INTERFACE WITH LIKE STYLE CONNECTORS

ITEM NUMBER	DESCRIPTION
10	GASKET FOAM ADH ACRYLIC/ACRYLIC
9	NUT OCT M11X1 POM BLACK
8	SHRINK TUBE 2:1 POLYOL BLACK
7	CONNECTOR RP-SMA TYPE GOLD/BRASS
6	CABLE COAX RG174U BLACK
5	GUIDE CABLE 418 ABS DK BLUE
4	COUNTERPOISE 418 ELEM NICKEL/BRASS
3	BASE THREADED M11X1 ABS BLACK
2	ELEMENT 418MHz COIL SWC
1	COVER ELEMENT ABS BLACK

DESIGN TABLE	
PART NUMBER	CABLE LENGTH
ANT-418-WRT-RPS	216±2mm [8.50]

THIS DRAWING IS A CONTROLLED DOCUMENT.		DWN JHAGER 10/8/20
DIMENSIONS: mm		CHK CLEWIS 10/8/20
TOLERANCES UNLESS OTHERWISE SPECIFIED:		APVD CMURPHY 10/8/20
0 PLC ± 1.0		PRODUCT SPEC -
1 PLC ± 0.5		APPLICATION SPEC -
2 PLC ± 0.13		WEIGHT 10.940 g
3 PLC		CUSTOMER DRAWING
4 PLC		SCALE 1.5:1
ANGLES ± 30'		SHEET 1 OF 1
MATERIAL ABS+UV	FINISH	REV C

**TE** TE Connectivity

## ANTENNA 418 WRT DOME RG174 COAX W/RP-SMA CONNECTOR

SIZE <b>A3</b>	CAGE CODE 00779	DRAWING NO ANT-418-WRT-RPS-LLL	RESTRICTED TO -
-------------------	--------------------	-----------------------------------	--------------------