

REVISIONS			
REV	DESCRIPTION	DATE	APPV
A	PRODUCTION RELEASE	JHAGER 10/18/20	DV 1/3/21
B	UPDATED CABLE LENGTH TOLERANCE WAS ±1mm	JHAGER 10/29/21	DV
C	UPDATED DRAWING TO REDUCE TABULATED VARIABLES. DRAWING WAS ANT-FFF-WRT-CCC	JHAGER 3/8/22	

THIS DRAWING IS A CONTROLLED DOCUMENT

DWG NO
ANT-433-WRT-SMA-LLL

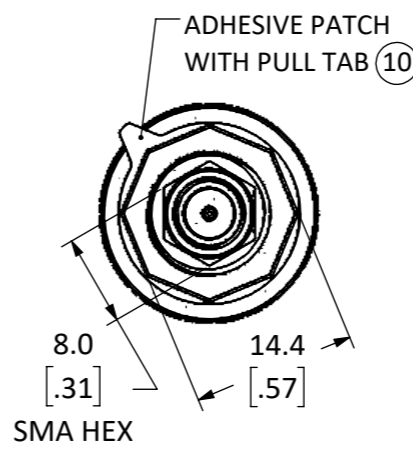
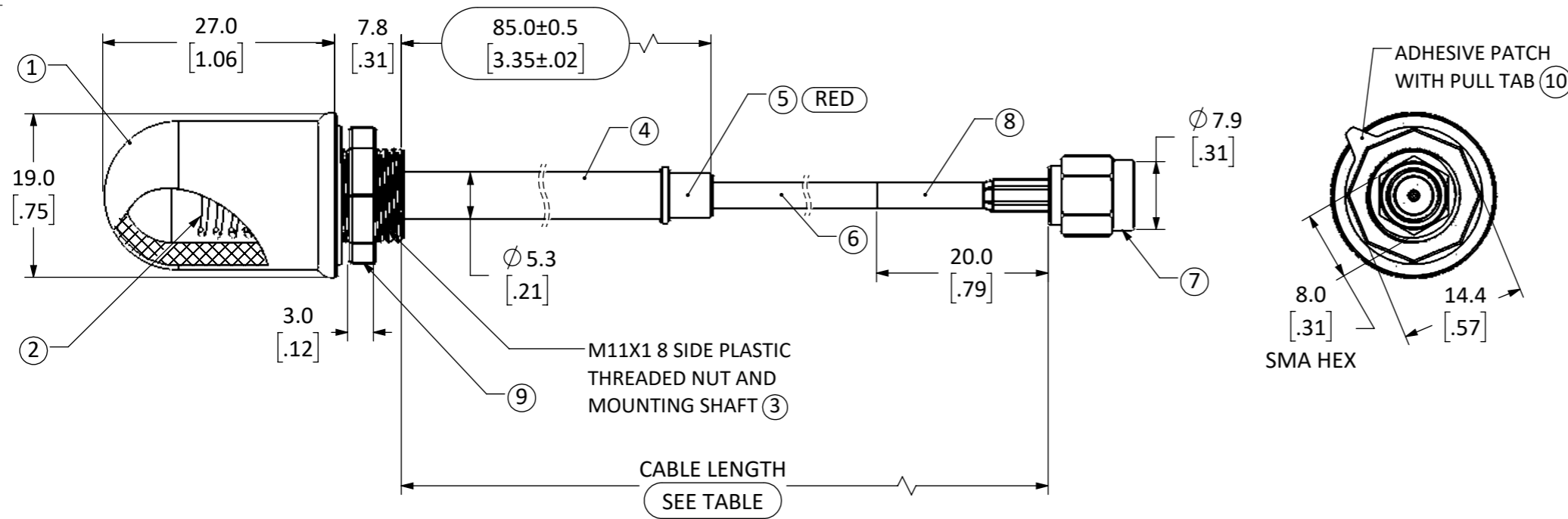

- NOTES: (UNLESS OTHERWISE SPECIFIED)
- ALL DIMENSIONS ARE IN MILLIMETERS [in].
 - DIMENSIONS APPLY AFTER FINISHING.
 - MANUFACTURE TO BE COMPLIANT WITH EU RoHS DIRECTIVE, USE MATERIALS THAT DO NOT CONTAIN REACH SUBSTANCES OF VERY HIGH CONCERN >1000ppm, AND USE DRC CONFLICT-FREE SOURCED MATERIALS.
 - PACKAGE ANTENNAS INDIVIDUALLY PRIOR TO PLACING IN LOT BAG.
 - ANTENNA QUALIFIED AND TESTED IAW INTERNAL TEST PLAN DOCUEMNT AT LATEST REVISION.
 - ELECTRICAL DATA SHOWN FOR REFERENCE ONLY. SEE DATA SHEET FOR COMPLETE ELECTRICAL PROPERTIES:
 - CENTER FREQUENCY 433 MHz
 - 50Ω IMPEDANCE
 - VSWR <1.9 TYP @ CENTER
 - MECHANICAL:
 - USE TEMPERATURE: -40°C - +90°C
 - INSTALLATION TEMPERATURE: +10° - +40°C
 - STORAGE TEMPERATURE: +20° @ 50%RH
 - BULKHEAD PLASTIC NUT TORQUE: NTE 4.0kgf/cm [5in/lbS]
 - Ø.425" [10.8mm] RECOMMENDED INSTALL HOLE SIZE
 - DEBURR INSTALLATION HOLE AND ENSURE TEXTURE HAS BEEN REMOVED FROM PSA MOUNTING SURFACE
 - FOR LOW ENERGY MOUNTING SURFACE IT IS RECOMMENDED THAT AN ADHESION PROPOTOR IS APPLIED PRIOR TO INSTALLATION.
 - MINIMUM BEND RADIUS: 10.2mm
 - MAX PANEL THICKNESS: 4.7mm [.188"]
 - INTERFACE SMA TYPE IAW MIL-STD-348B

DESIGN TABLE	
PART NUMBER	CABLE LENGTH
ANT-433-WRT-SMA	216±2mm [8.50]
ANT-433-WRT-SMA-300	300±2mm [11.81]

ITEM NUMBER	DESCRIPTION
10	GASKET FOAM ADH ACRYLIC/ACRYLIC
9	NUT OCT M11X1 POM BLACK
8	SHRINK TUBE 2:1 POLYOL BLACK
7	CONNECTOR SMA-TYPE GOLD/BRASS
6	CABLE COAX RG174U BLACK
5	GUIDE CABLE 433 ABS RED
4	COUNTERPOISE 433 ELEM NICKEL/BRASS
3	BASE THREADED M11X1 ABS BLACK
2	ELEMENT 433MHz COIL SWC
1	COVER ELEMENT ABS BLACK

THIS DRAWING IS A CONTROLLED DOCUMENT.		DWN JHAGER 9/24/20			
		CHK CLEWIS 9/26/20			
DIMENSIONS: mm		APVD DASARATHAN 3/1/21	ANTENNA 433MHZ WRT TYPE DOME RG174 COAX WITH SMA CONNECTOR		
		PRODUCT SPEC -			
TOLERANCES UNLESS OTHERWISE SPECIFIED:		APPLICATION SPEC -	SIZE A3		
0 PLC ± 0.5 1 PLC ± 0.25 2 PLC ± 0.13 3 PLC 4 PLC ANGLES ± 30'		WEIGHT 10.940 g			
MATERIAL ABS+UV BLACK		FINISH	CAGE CODE 00779	DRAWING NO ANT-433-WRT-SMA-LLL	RESTRICTED TO -
		CUSTOMER DRAWING	SCALE 1.5:1	SHEET 1 OF 1	REV C