

HF (13.56 MHz)
 BIS M-143-02/A-T6-SA3
 Order Code: BIS010N

BALLUFF

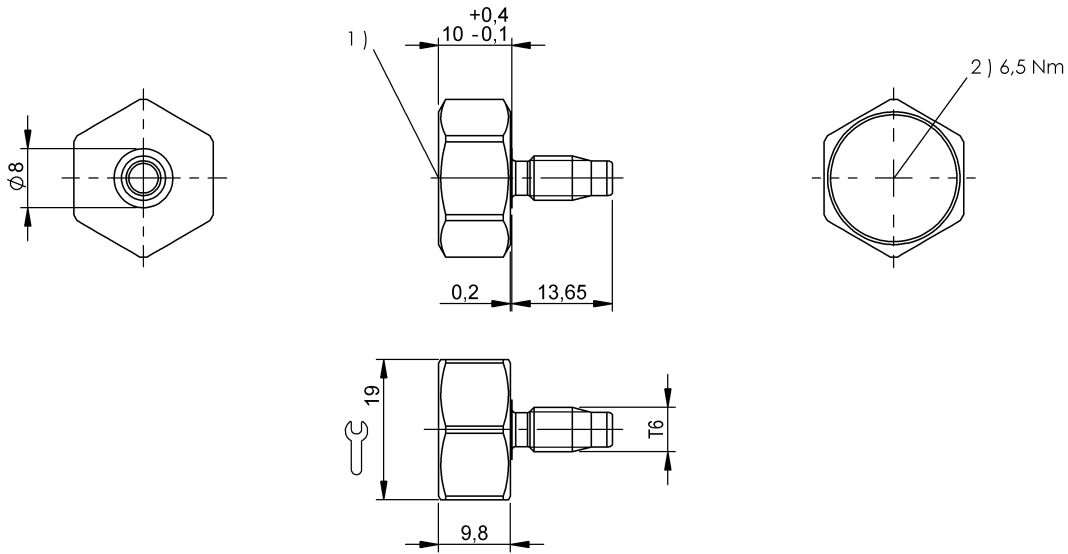

1) Sensing surface, 2) Tightening torque



Basic features

Antenna type	round
Approval/Conformity	CE UKCA WEEE
EN 55022	Size 1, Cl. B
Principle of operation	Data carrier

Electrical data

Data retention time/years	≥ 10 at 55 °C
Memory organization	250 × 8 bits
Programming cycles	≥ 10.000.000.000
Programming time	for 16 bytes: 0.060s
Read cycles	Unlimited
Read time	User ID for 8 bytes: 0.02 s for 16 bytes: 0.03 s

Environmental conditions

Ambient temperature	-25...70 °C
Continuous shock load	yes
EN 60068-2-27, Shock	yes
EN 60068-2-32 Free fall	yes
EN 60068-2-6, Vibration	yes
IP rating per DIN 40050	IP68 IPx9K

Functional Characteristics

Memory type	FRAM
UID serial number, read-only	8 Byte
User data, read/write	2000 Byte

Material

Housing material	Steel, Data carrier: PA 12-GF30, coated
Housing material, surface protection	coated

Mechanical data

Application weight	16.00 g
Dimension	19 × 23.65 mm

HF (13.56 MHz)
BIS M-143-02/A-T6-SA3
Order Code: BIS010N

BALLUFF

Remarks

Values are under rated conditions unless otherwise specified.
Only when used together with the appropriate read/write head.
For installation requirements see corresponding read/write head.
Time specification includes data check.
Lubricate screw before installing.
We recommend lightly oiling the data carrier screws and storing in a dry location at room temperature.