

REVISIONS			
REV	DESCRIPTION	DATE	APPV
B	ADDED PACKAGING INFORMATION, MHF4 CONFIG, BEND RAD AND MAX PNL THICKNESS, UNIT WAS INCH	JHAGER 10/28/21	DV 11/10/21
C	ADDED MHF3 PER SETUP FORM 11/21	JHAGER 1122/21	DV 11/25/21
D	UPDATED DRAWING TO REMOVE HEATSHRINK FROM 1.13 AND 1.32 CABLE TYPES UPDT NOTES	JHAGER 12/15/21	DV
E	UPDATED DESIGN TO REDUCE TABULATION VARIABLES. DRWG WAS ANT-DB1-WRT-CCC	JHAGER 3/4/2022	

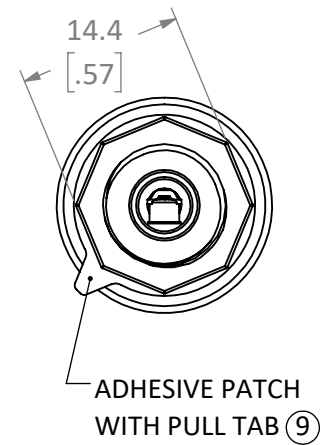
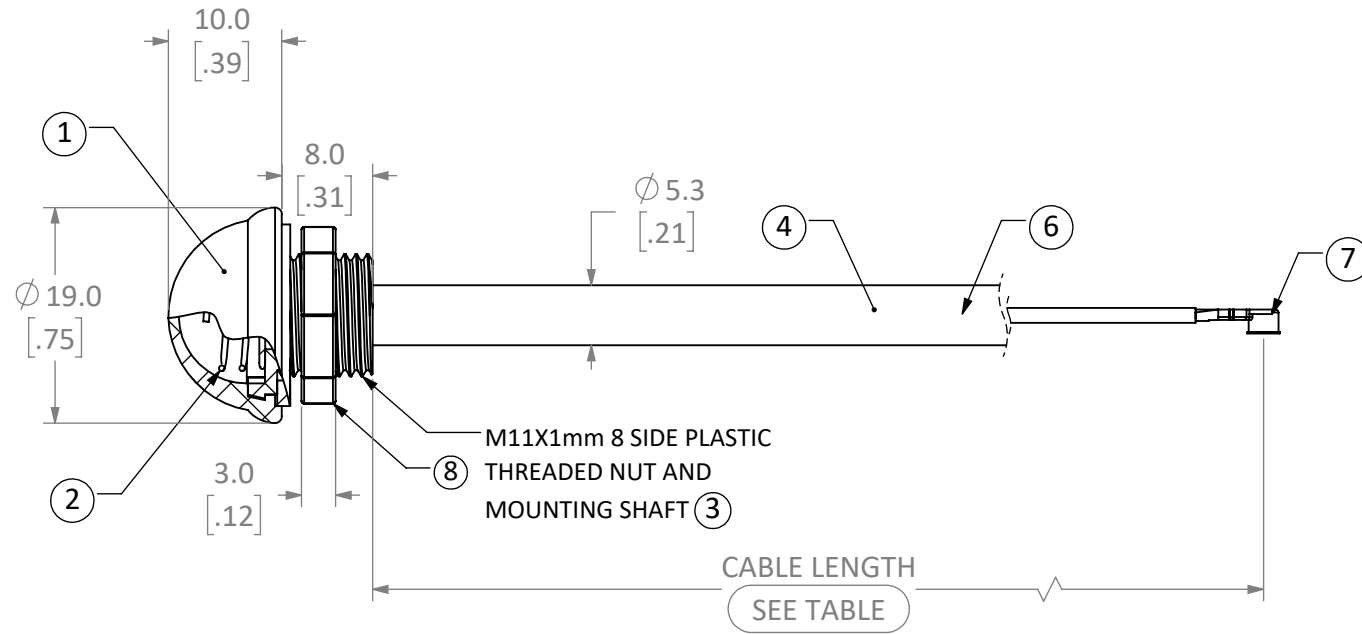

NOTES: (UNLESS OTHERWISE SPECIFIED)

- ALL DIMENSIONS ARE IN MILLIMETERS [in].
- DIMENSIONS APPLY AFTER FINISHING.
- MANUFACTURE TO BE COMPLIANT WITH EU RoHS DIRECTIVE, USE MATERIALS THAT DO NOT CONTAIN REACH SUBSTANCES OF VERY HIGH CONCERN >1000ppm, AND USE DRC CONFLICT-FREE SOURCED MATERIALS.
- PACKAGE ANTENNAS INDIVIDUALLY PRIOR TO PLACING IN LOT BAG. LABEL LOT BAG, AND BOX WITH THE FOLLOWING INFORMATION ONLY:
 - LOT NUMBER
 - LINX PART NUMBER
 - QUANTITY
 - COUNTRY OF ORIGIN
- ANTENNA QUALIFIED AND TESTED IAW LINX INTERNAL TEST PLAN DOCUMENT AT LATEST REVISION.
- ELECTRICAL DATA SHOWN FOR REFERENCE ONLY. SEE LINX DATA SHEET FOR COMPLETE ELECTRICAL PROPERTIES:
 - CENTER FREQUENCY DUAL BAND
 - BAND1: 2.4GHz
 - BAND2: 5.8GHz
 - 50Ω IMPEDANCE
 - VSWR <2.0 TYP @ CENTER
- MECHANICAL:
 - USE TEMPERATURE: -40°C - +90°C
 - INSTALLATION TEMPERATURE: +10° - +40°C
 - STORAGE TEMPERATURE: +20° @ 50%RH
 - BULKHEAD PLASTIC NUT TORQUE: NTE 4.0kgf/cm [5in/lbS]
 - Ø.425" [10.8mm] RECOMMENDED INSTALL HOLE SIZE
 - MINIMUM BEND RADIUS: 6mm
 - MAX PANEL THICKNESS: 4.7mm [.188"]
 - INTERFACE U.FL/MHF1 TYPE
 - WEIGHT: 12.5g

ITEM NUMBER	DESCRIPTION
9	GASKET FOAM ADH ACRYLIC/ACRYLIC
8	NUT OCT M11X1 POM BLACK
7	CONNECTOR UFL/MHF1 GOLD/BRASS
6	CABLE COAX 1.32mm GRAY
5	GUIDE CABLE DB1 ABS LT GRAY
4	COUNTERPOISE DB ELEM NICKEL/BRASS
3	BASE THREADED M11X1 ABS BLACK
2	ELEMENT DB 2.4/5.8GHz COIL SWC
1	COVER ELEMENT ABS BLACK

DESIGN TABLE	
LINX PART NUMBER	CABLE LENGTH
ANT-DB1-WRT-UFL	216±2mm [8.50]
ANT-DB1-WRT-UFL-100	100±2mm [3.94]
ANT-DB1-WRT-UFL-150	150±2mm [5.90]

WARNING: THIS DRAWING CONTAINS PROPRIETARY INFORMATION THAT IS THE SOLE PROPERTY OF LINX TECHNOLOGIES, AND SHALL BE TREATED AS SUCH. NO DISCLOSURE OR REPRODUCTION OF THIS DOCUMENT IS PERMITTED, IN WHOLE OR IN PART, WITHOUT THE EXPRESS WRITTEN PERMISSION OF LINX TECHNOLOGIES OR ITS DESIGNATED AGENTS.

MATERIAL:	INTERPRET DIMENSIONS AND TOLERANCES PER ASME Y14.5.	PROJECTION:
WEIGHT:	.X ±2.0 .XX ±1.00 .XXX ±.500	
FINISH:	ANGLES: ±1° SURFACE:	
DRAWN: JHAGER	DT: 10/8/20	
ENGR: DASARATHAN	DT: 3/1/21	

STE connectivity 159 ORT LANE
MERLIN, OR 97532

TITLE: ANTENNA PURCHASED ASSEMBLY WRT VAR END CONN AND PACK		
SIZE B	DWG. NO. C-ANT-DB1-WRT-UFL-LLL	REV E
SCALE: 1.5:1	DO NOT SCALE DRAWING	SHEET 1 OF 1