

Mechanical Cam Switches  
**BNS 819-D06-D12-62-10**  
 Order Code: BNS01LE

**BALLUFF**

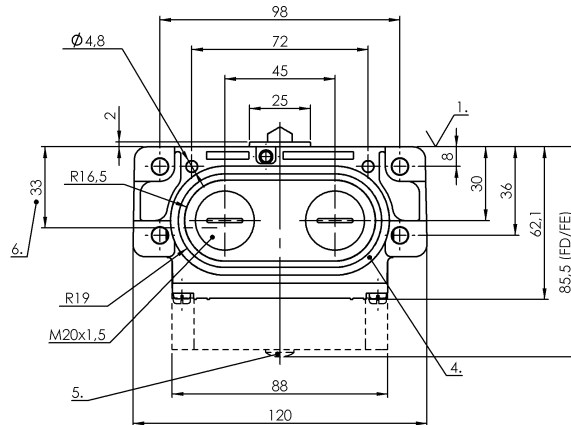
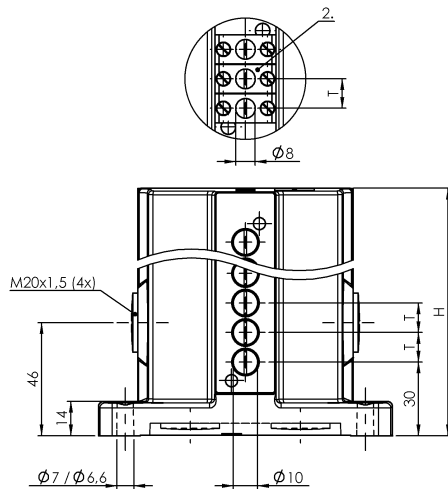

**Basic features**

<b>Approval/Conformity</b>	CE UKCA CCC WEEE
<b>Basic standard</b>	IEC 60947-5-1
<b>Operating principle</b>	1-6. Switch position: Mechanical
<b>Version</b>	Snap contact

**Display/Operation**

<b>Function indicator</b>	1-6. Switch position: None
---------------------------	----------------------------

**Electrical connection**

<b>Connection type</b>	1-6. Switch position: Screw terminal
------------------------	--------------------------------------

**Electrical data**

<b>Continuous current</b>	1-6. Switch position: 6 A
<b>Rated operating voltage Ue</b>	1-6. Switch position: 250 V AC
<b>Switching function mechanical</b>	Double-interrupting galvanically isolated One NO and one NC Dual changeover
<b>Switching rate</b>	1-6. Switch position: 300/min

**Environmental conditions**

<b>Ambient temperature</b>	-5...85 °C
<b>IP rating</b>	IP67

**Functional safety**

<b>B10d (EN ISO 13849-1)</b>	BSE 30.0: 30 mil. switching cycles
------------------------------	------------------------------------

**Material**

<b>Housing material</b>	Aluminium, Anodized
<b>Housing material, surface protection</b>	Anodized
<b>Material contacts</b>	1-6. Switch position: Silver, gold plated
<b>Plunger material</b>	1-6. Switch position: 1.4034 stainless steel

**Mechanical data**

<b>Approach direction</b>	longitudinal, parallel to attachment surface
<b>Approach speed</b>	1-6. Switch position: 40 m/min
<b>Dimension</b>	120 x 112 x 62 mm
<b>Distance cam - reference edge</b>	1-6. Switch position: 4.50...5.00 mm
<b>Flange, feed-through</b>	2 threaded exit M20
<b>Installation</b>	Vertical
<b>Life expectancy mechanical</b>	1-6. Switch position: 30 mil. switching operations
<b>Number of switching positions</b>	6x Chisel Mechanical
<b>Plunger spacing 1st switch position</b>	30 mm
<b>Plunger style</b>	1-6th switch position: Chisel
<b>Switch actuation force</b>	1-6. Switch position: 20 N
<b>Switching element</b>	1-6. Switch position: BSE 30.0

**Range/Distance**

<b>Reproducibility</b>	1-6. Switch position: ±0.002 mm
<b>Switch position spacing</b>	12 mm

## Wiring Diagrams

BSE 30.0

