

Mechanical Cam Switches
BSE 85-RK
 Order Code: BSE000N

BALLUFF

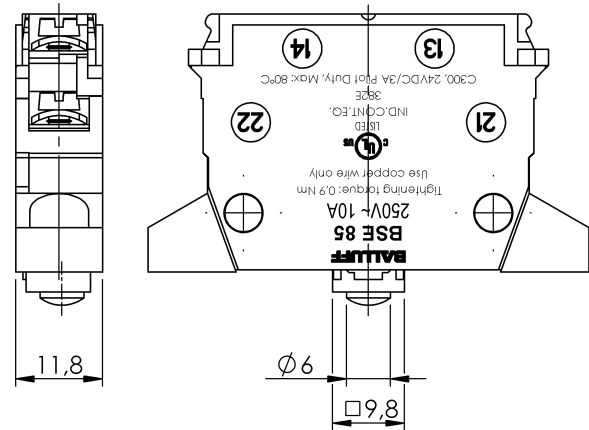
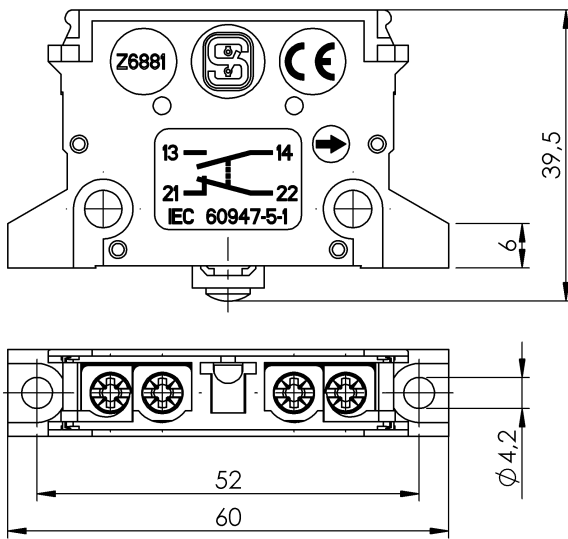

Basic features

Approval/Conformity	CE UKCA cULus CCC WEEE
Bounce time max.	3.00 ms
Switching time	5 ms
Use with series	EGT F60 RGT 100 RGT 61 RGT 62 RGT 72

Electrical connection

Connection	M3.5
Connection type	1. Switch position: Screw terminal
Contact system	Dual changeover One NO and one NC galvanically isolated Double-interrupting NC forced-opening per VDE Normally open with snap funct.

Electrical data

Contact arrangement	NC: 21+22 NO: 13+14
Contact resistance max.	40 mOhm
Contact resistance max., note	New condition
Continuous current	1. Switch position: 6.0 A
Mechanical life expectancy min.	1 mil. switching operations
Minimum load at 24 V DC	20 mA
Nominal voltage	250 VAC
Switching actuation force max.	18.00 N
Switching capacity at 250 V AC 40...60Hz	2 A cos ϕ = 0.8
Switching operations per minute	160
Switching principle	Snap switch
Switchover time max.	10 ms

Environmental conditions

Ambient temperature	-5...85 °C
----------------------------	------------

Material

Cover material	Thermoplast
Housing material	Thermoplast, GF
Material contacts	Silver
Material contacts	1. Switch position: Silver

Mechanical data

Connection cross-section	1.5 mm ²
Tightening torque max.	120 Ncm