

REVISIONS				
P	LTR	DESCRIPTION	DATE	APVD
	A1	NEW DRAWING	10NOV2023	ASB LET

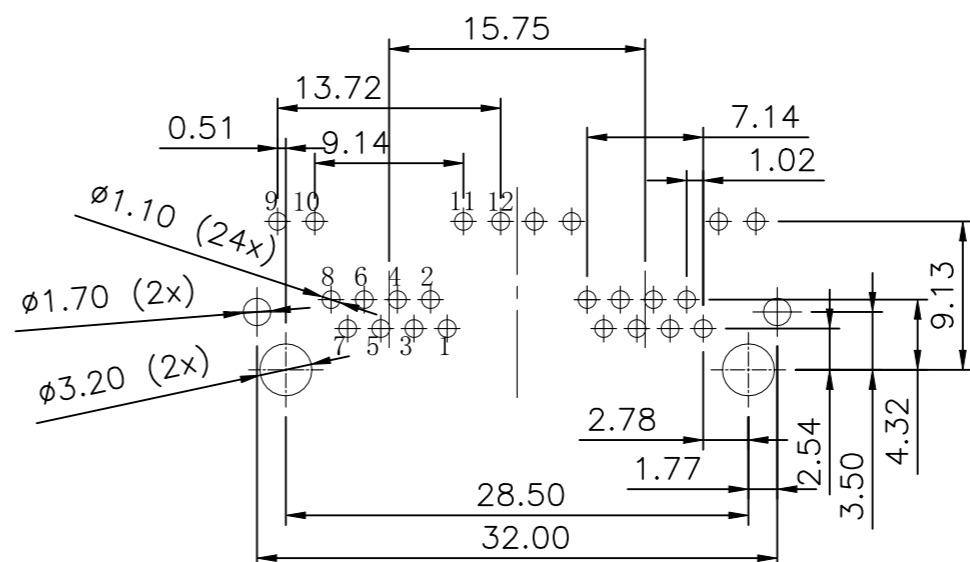

RECOMMENDED PCB LAYOUT TOP VIEW  
COMPONENT SIDE TOLERANCE±0.05 THICKNESS=3.0mm

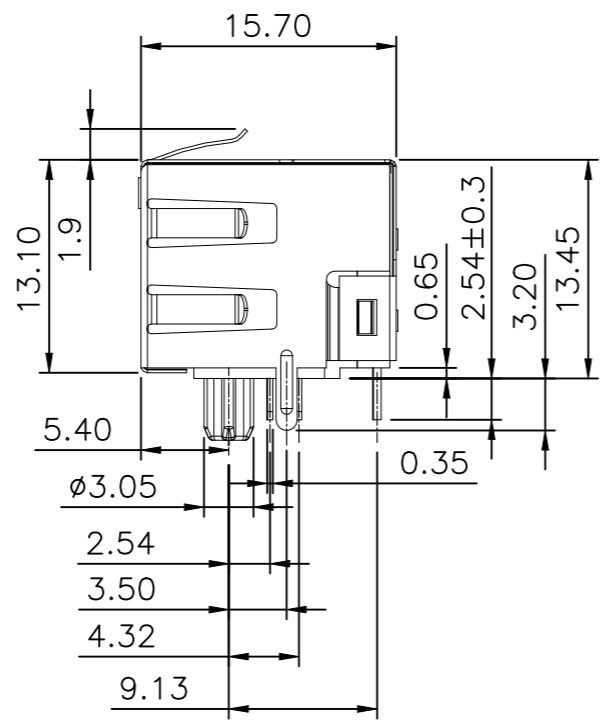
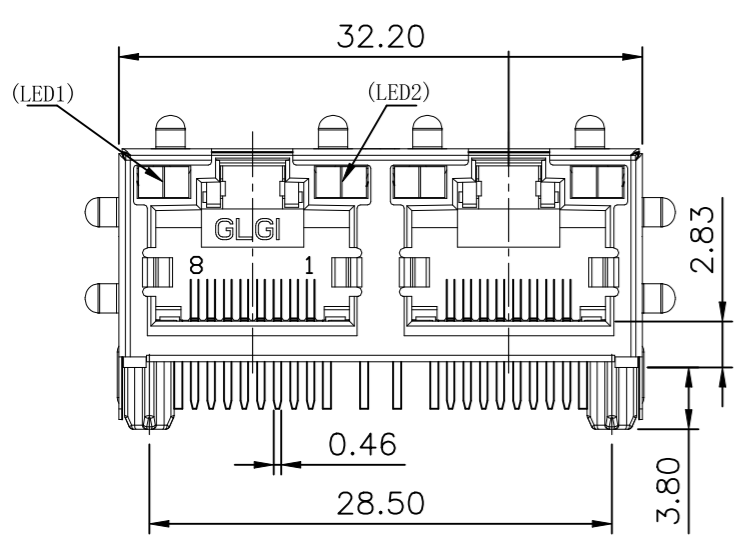
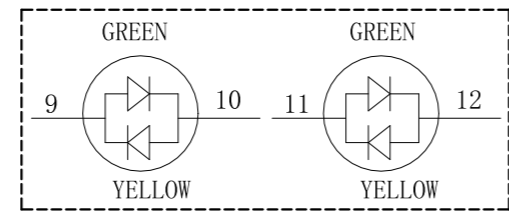
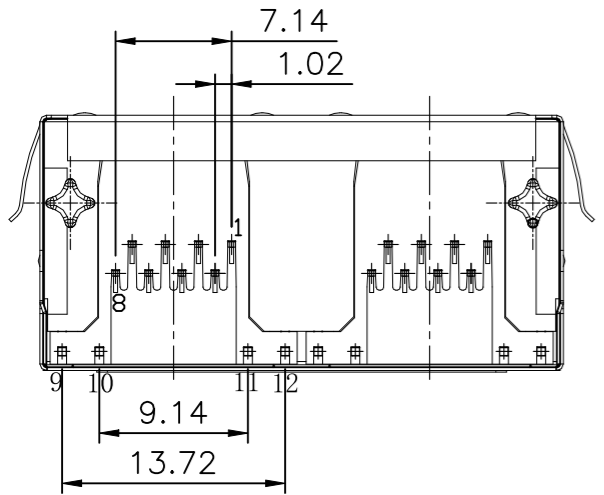

LED PIN DEFINE

	WAVELENGTH		
	MINIMUM VALUE	AVERAGE VALUE	MAXIMUM VALUE
GREEN/YELLOW	565/585	569/588	570/590

FORWARD VOLTAGE: VF=1.8-2.4V  
FORWARD CURRENT: IF=20mA

- 1. CONNECTOR MATERIAL:  
HOUSING:LCP BLACK UL94V-0  
INSERT:LCP BLACK UL94V-0.  
SHIELD:COPPER ALLOY, THICKNESS 0.2mm  
SHIELD PLATING:NICKEL  
CONTACT:PHOSPHOR BRONZE  
CONTACT PLATING:30µinch GOLD PLATING ON CONTACT AREA.  
50µinch MIN.NICKEL UNDERPLATED OVER ALL.  
80µinch MIN.MATTE-TIN ON SOLDER TAIL.
- LED1:GREEN/YELLOW  
LED2:GREEN/YELLOW
- 2. RJ45 CAVITY DIMENSION CONFORM TO FCC PART 68.
- 3. PACKAGING:TRAY ACCORDING TO PACKAGING SPECIFICATION 107-18116
- 4. PROP 65 WARNING LABEL:SEE SHEET 2

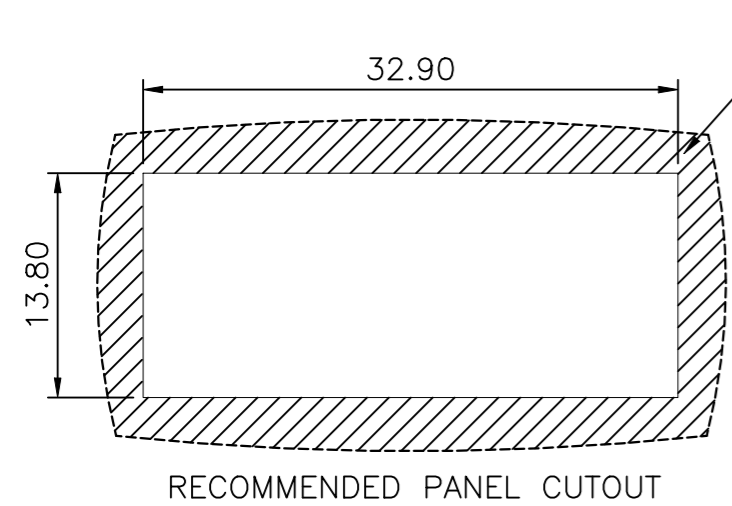

RECOMMENDED PANEL CUTOUT

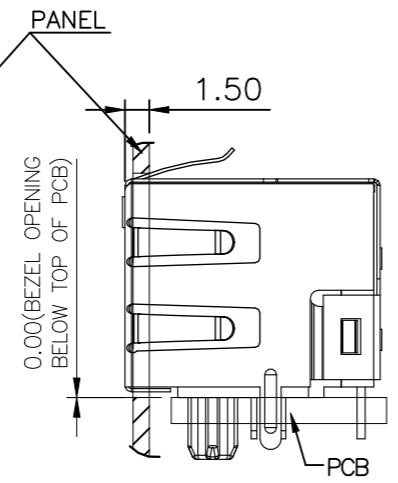

THIS DRAWING IS A CONTROLLED DOCUMENT.		DWN B S ADRUSH 10NOV2023	TE Connectivity	
DIMENSIONS: mm		CHK N MANTIKOU 12NOV2023		
TOLERANCES UNLESS OTHERWISE SPECIFIED:		APVD T LEININGER 12NOV2023	NAME RJ45 JACK THT 1Gb R/A LED 1X2	
0 PLC ± -	1 PLC ± 0.35	PRODUCT SPEC 108-94945	-	
2 PLC ± 0.25	3 PLC ± 0.15	APPLICATION SPEC 114-97854	-	
4 PLC ± -	ANGLES ± 2°	WEIGHT 7.36g	SIZE A3	CAGE CODE 00779
MATERIAL ①	FINISH ①	DRAWING NO C-2501550-8		RESTRICTED TO -
CUSTOMER DRAWING			SCALE NTS	SHEET 1 OF 2
			REV A1	

REVISIONS					
P	LTR	DESCRIPTION	DATE	DWN	APVD
	-	SEE SHEET 1	-	-	-

NOTES: CONTINUATION FROM SHEET 1:

4 PROP 65 WARNING LABEL:

- THE WARNING LABEL ON THE PRODUCT OR LOWEST LEVEL PACKAGING
- CHEMICAL NAME: NICKEL (METALLIC)



**WARNING:** This product can expose you to chemicals including NICKEL (METALLIC) which is known to the state of California to cause cancer. For more information, visit [www.P65Warnings.ca.gov](http://www.P65Warnings.ca.gov).

THIS DRAWING IS A CONTROLLED DOCUMENT.		DWN B S ADRUSH 10NOV2023	<b>STE</b> TE Connectivity		
		CHK N MANTIKOU 12NOV2023			
DIMENSIONS: mm		APVD T LEININGER 12NOV2023	NAME RJ45 JACK THT 1Gb R/A LED 1X2		
TOLERANCES UNLESS OTHERWISE SPECIFIED:		PRODUCT SPEC 108-94945	-		
0 PLC ± -		APPLICATION SPEC 114-97854	SIZE	CAGE CODE	DRAWING NO
1 PLC ± 0.35		WEIGHT 7.36g	A3	00779	C-2501550-8
2 PLC ± 0.25		CUSTOMER DRAWING		SCALE	SHEET
3 PLC ± 0.15				NTS	2 OF 2
4 PLC ± -				REV	A1
ANGLES ± 2°					
MATERIAL	FINISH	RESTRICTED TO			
1	1	-			